

We are IntechOpen, the world's leading publisher of Open Access books Built by scientists, for scientists

5,800

Open access books available

142,000

International authors and editors

180M

Downloads

Our authors are among the

154

Countries delivered to

TOP 1%

most cited scientists

12.2%

Contributors from top 500 universities



WEB OF SCIENCE™

Selection of our books indexed in the Book Citation Index
in Web of Science™ Core Collection (BKCI)

Interested in publishing with us?
Contact book.department@intechopen.com

Numbers displayed above are based on latest data collected.
For more information visit www.intechopen.com



xIoT-Based Converged 5G and ICT Infrastructure

Ahmed Y. Hassebo

Abstract

This chapter examines and explores the potential of how the capabilities of the emerging 5G cellular technologies can be integrated with a given mission-critical xIoT application (e., g., smart grid) to enable a truly converged xIoT-ICT infrastructure that would further enhance and enable the adequate support of the strict performance requirement of such an xIoT application. Since the smart grid believed to be one of the most necessitated IoT services. in this work, it has been nominated as a descriptive xIoT case. As the smart grid comprises an extensive collection of applications extended from mission-critical services which have rigorous necessities in terms of end-to-end (E2E) latency and reliability (e.g., real-time system protection and control utilizing PMU measurements) to those that require support of massive number of connected machine-to-machine (M2M) devices with relaxed latency and reliability requirements (e.g., smart meters). Based on time-to-market strategy, we identify and propose two different 5G-based business and architectural models that enable a truly converged power grid-ICT infrastructure, namely, near-term model and long-term model.

Keywords: IoT, 5G, ICT, Smart Grid, PON, Slicing, and Mission-Critical

1. Introduction

Distributed energy resources (DERs) comprising wind and photovoltaic (PV) systems, joint heat and power systems, energy storage, demand response (DR), and microgrids. In addition, plug-in electric vehicle (PEV), vehicle-to-grid (V2G) and supportive electric vehicle supply equipment (EVSE) systems are controlled to transform the landscape of the universal energy market. Nowadays, an international and domestic widespread change is pervading. Recently, as early as 2018, the grid automation and demand response expenditure has touched \$70 billion worldwide and estimates depict that distributed capacity additions will surpass new centralized generation capacity additions [1]. The historic treaty developed from the latest universal Paris climate summit obligating all countries to act in contradiction to climate change will vividly fast-track the universal distribution of renewables and distributed generation (DG). It starts the launch of the conclusion of the fossil fuel epoch and the dynamic conversion to a novel clean DER-dependent universal energy market.

A universal integration of DERs into typical energy generation is fundamentally efficient to transform from the current conventional centralized grid to a strictly smart grid. To be truly smart, the power grid must provide a secure two-way flow

of data throughout the entire grid assets, including millions of intelligent electronic devices (IEDs) such as sensors and smart meters, electrical appliances, switches, gateways, Supervisory Control and Data Acquisition System (SCADA) control centers, databases, and consumers. A universal, efficient, and economical DER implementation necessitates boosted positional knowledge so that the system operator is aware of devices and its location. The entire grid necessitates a boosted vision down to the distribution system and end user/device level. This will necessitate a superior dependance on the Information and Communication Technology (ICT).

Many utilities have already started investing in the distribution grid by deploying sensor systems and Advanced Metering Infrastructure (AMI). AMI is consisting of smart meters, communication networks and information management systems. Nationally, it is anticipated that about 65 million smart meters will be implemented by 2015, accounting for at least a third of all U.S. electricity customers [2]. To support AMI deployment, wireless mesh networks are typically utilized because they are more affordable than fiber optics networks. These networks can only support basic meter reading functions since they lack the bandwidth and latency capabilities required to support advanced distribution automation.

Recently, distributed energy resource management systems (DERMS) have been developed as smart software solutions to tackle the economic and technical challenges modeled by the propagation of customer-owned distributed resources. The efficient management of DER is the fundamental role of a DERMS [2]. In 2030 and beyond, the grid operations are expected to be dominated by the microgrids and DER. In addition, numerous theoretical, industrialized and regularization research and development (R&D) have been established to encounter this challenge [3].

The power grid network comprises four functional areas, incorporating bulk generation, transmission, distribution, and consumption which are normally disseminated in a huge zone. The associated communication network infrastructure must cover all of these four divisions and is split into several classified networks. These networks comprising home area networks (HANs), neighborhood area networks (NANs), field area networks (FANs), and wide area networks (WANs), as depicted in **Figure 1**.

Several different wired and wireless networking technologies have been proposed as the underlying communication infrastructure for the smart grid including broadband power line communication (BPLC), Digital Subscriber Lines, cellular wireless (2G, 2.5G, 3G, and WiMAX), IEEE 802.15.4 g-based wireless HANs (ZigBee communication protocols), wireless sensor networks (WSNs), high-speed wireless local area networks (WLANs), e.g., WiFi, and IEEE 802.11 s-based multihop wireless mesh networks (WMNs), etc. Typically, different networking technologies and standards are adopted in different parts of the grid, e.g., PLC and/or IEEE 802.15.4 g may be used in HANs, IEEE 802.15.4 g and/or IEEE 802.11 s may be used in NANs, while IEEE 802.16 (WiMAX) is used in WANs [4]. All these networks have to be integrated into one larger seamless network to provide efficient data and control flow.

2. Recent research growth: challenges and motivations

As the grid develops, several diverse devices and systems will be incorporated into the distribution grid involving those of the predicted universal AMI, microgrid and PEV implementation. Therefore, for the anticipated smart grid, E2E interoperability implementation among these systems and devices in a simple and affordable approach is considered as an overwhelming mission. Various interfaces among diverse grid systems and components have been recognized by the US National

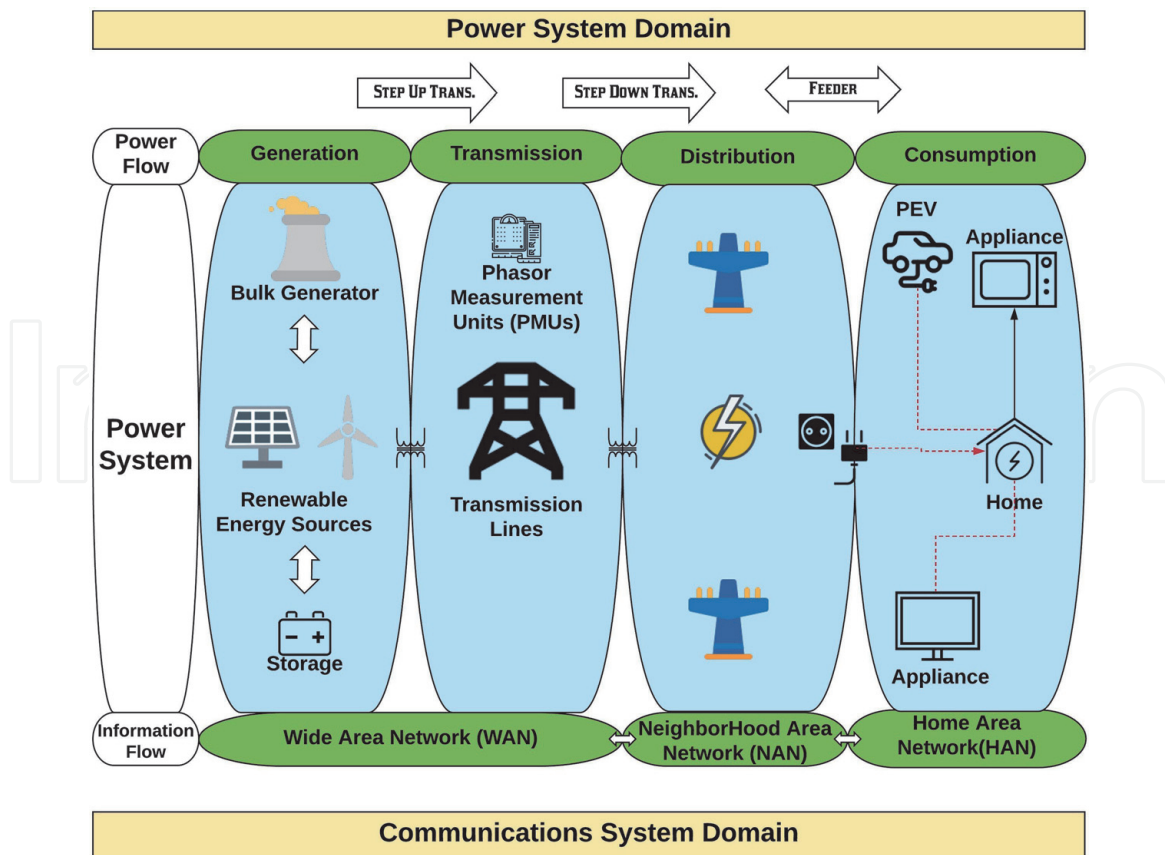

Figure 1.
Power grid components and power grid communications network.

Institute of Standards and Technology (NIST) Cyber security Working Group [5]. Devising a widely accepted seamless global communication networking technology standard across the entire grid segments will certainly greatly simplify the end-to-end interoperability challenge. As more and more devices and components are connected to future power grids, communication networks and computing are growingly integral to power grid operations and the notion of a truly converged power grid and ICT infrastructure is inevitable.

The potential grid communications networks possession, associated standards, and interoperability challenges are igniting a substantial dispute among all shareholders. The utilization of the services of the public commercial fixed/mobile networks or the dependence of the potential grid communications networks on the utility controlled private network is considered the center of the current argument. The Federal Communications Commission (FCC) recommends on the issue of grid data communications possession in its nationwide broadband strategy: “The nation should follow three similar tracks”. First, reinforcing the current commercial mobile networks (Long Term Evolution (LTE)/LTE-Advanced (LTE-A)) to provision mission critical smart grid services. Second, enabling the utilities to share the public safety mobile broadband network for mission critical communications. Third, essentially, utilities are authorized to create and control their private mission critical broadband networks” [2–4].

The miscellaneous use cases of potential power grid applications varying from mission critical applications to relaxed latency applications. The mission critical applications necessitate ultra-reliable and strict E2E latency, for example, system protection. While the relaxed latency applications provision massive number of connected devices with relaxed reliability requirements and latency necessities, for instance, smart meters. Point-to-point (P2P) fibers among the controller and every

device might be required to provide a strict E2E latency to the mission critical applications. Therefore, the ideal solution is to dedicate a private optical fiber network. A significant fiber capacity underutilization and fiber cost prohibitions conversely are due to a dedicated fiber network deployment for smart grid purposes.

In contrast, it has been agreed that utilizing significantly flexible and cost effective commercial cellular networks, for example, 4G LTE and/or LTE-A dependent Fifth Generation (5G) are significantly convincing technically and economically for the potential power grids. Due to its cost effectiveness and availability, using of 4G LTE is considered by multiple energetic service industries to support critical connections to smart devices, and sensors belong to their networks. However, typical 4G LTE networks cannot efficiently accommodate the diverging performance requirements of smart grid mission-critical applications in terms of latency, availability, and reliability.

Recently, Ultra-Reliable Low-Latency Communication (URLLC) paradigm has emerged to permit an innovative chain of mission-critical applications. These services comprising industrial automation, instantaneous operation, smart grid control, inter-vehicular communications for improved safety, and autonomous vehicles. URLLC is one of the most pioneering 5G New Radio (NR) features. URLLC and its supporting 5G NR technologies might become a commercial reality in the future, but it may be rather a distant future. Thus, it is most likely that deploying viable mission critical IoT applications won't be feasible in the near future, at least not before URLLC and 5G NR technologies become commercially available.

This study, driven by these challenges, investigates the evolving 5G cellular technologies potentially can be incorporated with the power grid to assist the implementation of a strictly smart grid (a congregated power grid ICT infrastructure). Numerous substantial economic and technical developments will significantly position LTE-A dependent 5G cellular technologies as a potential universal congregated grid communications standard. These include:

1. Smart grids, smart cities, smart homes, ehealthcare, and intelligent transportation systems (ITS) are considered as the IoT applications and services. To support billions of IoT devices/things with universal mobile connections, 5G will be considered as a groundbreaking solution.
2. The growth of LTE-A equipped Heterogeneous networks (HetNets) comprises a combination of macro-cell base stations (BS) and cost-effective low-power small cell (SC) BSs functioning over both licensed (e.g., femto cells and pico cells) and unlicensed (e.g., WiFi access points) bands [5–7].
3. Cell-based LTE-A equipped M2M and machine-type communications (MTC) [6, 7].
4. LTE/LTE-A has been already selected by US and EU federal authorities to be the technology for future public safety mobile broadband networks.

Based on time-to-market strategy, we identify and propose two different 5G-based business and architectural models that enable a truly converged power grid-ICT infrastructure, namely, near-term model and long-term model [8]. Utilization of the public commercial 5G cell-based network along with public commercial passive optical network (PON) dependent fiber-to-the home/node (FTTH/FTTN) is the near-term model which is the main focus of this study. In this model, utilities

can control the provisioning of the cell-based communication devices (LTE-A-equipped M2M module/SIM card). The fixed/mobile operators should stringently synchronize with the utilities to modify a portion of the core network (CN) and information systems [9]. The Telecom operator in the near-term model, should have the control of the fixed PON FTTH resources (wavelengths) as well as radio network resources and frequency licenses.

The concept of the evolving 5G network slicing is the base of the second long-term model [10]. The 5G network slicing has been empowered by the latest swift networking developments in mobile edge computing and storage proficiencies, software defined networks (SDN), and network functions virtualizations (NFV). Extensive various IoT applications (Verticals) are to be supported by 5G, each vertical with its own distinctive set of service, performance necessities, machine type communications, and numerous logical (virtual) networks. Each virtual network is designed for a particular vertical, which must be built on the top of the common physical 5G infrastructure. Each logical network is denoted as a 5G network slice. Each network slice comprises of a combination of common and dedicated resource instances, for example, radio spectrum or network equipment, and virtual network function (VNF). Consequently, each slice will have its own virtual mobile CN as well as its own radio access network (RAN) functionalities. All network slices would be different and independently configured. Thus, under the second model, the 5G-network slice that is assigned to the smart grid must:

1. Have its own set of resources and functionalities
2. Totally isolated from all other network slices
3. Fully managed and controlled by the utility or a third-party provider independent of all other network slices [4].

3. The near-term model: a hybrid fiber/5G-based converged power grid-communication networking infrastructure

The near-term model utilizes public commercial 5G cellular network and technologies along with public commercial PON-based fiber-to-the-Node/Home (FTTN/FTTH) residential access network.

The evolving 5G cell-based network technologies are the core of the anticipated architecture. This architecture utilizes LTE-A equipped M2M communications and HetNet infrastructure as the solitary cellular technology that effortlessly extending from HAN to NAN to MAN to global. Moreover, the projected architecture uses an affordable fiber-dependent SC backhaul infrastructure, which exploits the present fibered services linked with a PON-dependent FTTH/FTTN domestic access network. Consequently, the projected hybrid-networking infrastructure implies the fiber network reliability and the community cell-based network flexibility.

The projected community cell-based network allows utilities to wirelessly connect to the universal distribution grid assets. Assets comprising smart meters, smart home appliances, PEV charging infrastructure, microgrids, substations, feeders (connected from substations to the client location), circuit breakers, transmission towers, and mobile workforce. Related to the grid assets, there is at least one cost-effective static embedded chip set (LTE-A equipped M2M unit), or mobile in the case of PEVs, that transmits and collects data to/from the macro-BSs, micro-BSs, or another M2M unit. The direct M2M communications is merely necessary in the

HANs and microgrid/PEVs. On the other hand, the communications among the other M2M components are dedicated for data forwarding only.

Per 3GPP standard, LTE/LTE-A comprises of an improved BS called evolved NodeB (eNB) and a mobile CN called evolved packet core (EPC) on the core side. Basically, EPC logical components comprises of mobility management entity (MME) in the control plane. On the other hand, the bearer plane is composed of the serving gateway (S-GW) and the packet data network gateway (P-GW). Practically, as one physical network defined as access gateway (A-GW), both gateways can be implemented based on vendor support and deployment scenarios [11]. The collected control and monitoring traffic is processed by the manager and then transmits the commands back to the $DERMS_i$ manager. The manager may forward these data before and/or after processing it to the control center and utility data.

3.1 Proposed hybrid fiber-based & LTE-A enabled HetNet & M2M communications architecture

Figure 2 illustrates the proposed architecture covering a utility's service territory in the coverage zone of a single macro-BS and numerous micro-BSs. Macro-BS coverage area may be extended to include at least one substation that are adjacent electrically, connected to the same node on the transmission system (necessary to regulate the power network), smart grid assets, as well as electric storage. Utility control, data center(s), headquarters, enterprise office locations, bulk power locations (owned by the utility), optical line terminal (OLT), EPC, and M2M application server, are all connected through dedicated fiber links.

A Public microgrid $DERMS_i$ manager is assembled with each optical network unit (ONU), which receives control data traffic from a group of public microgrid's central controllers (MGCC). In other words, LTE-A equipped M2M modules

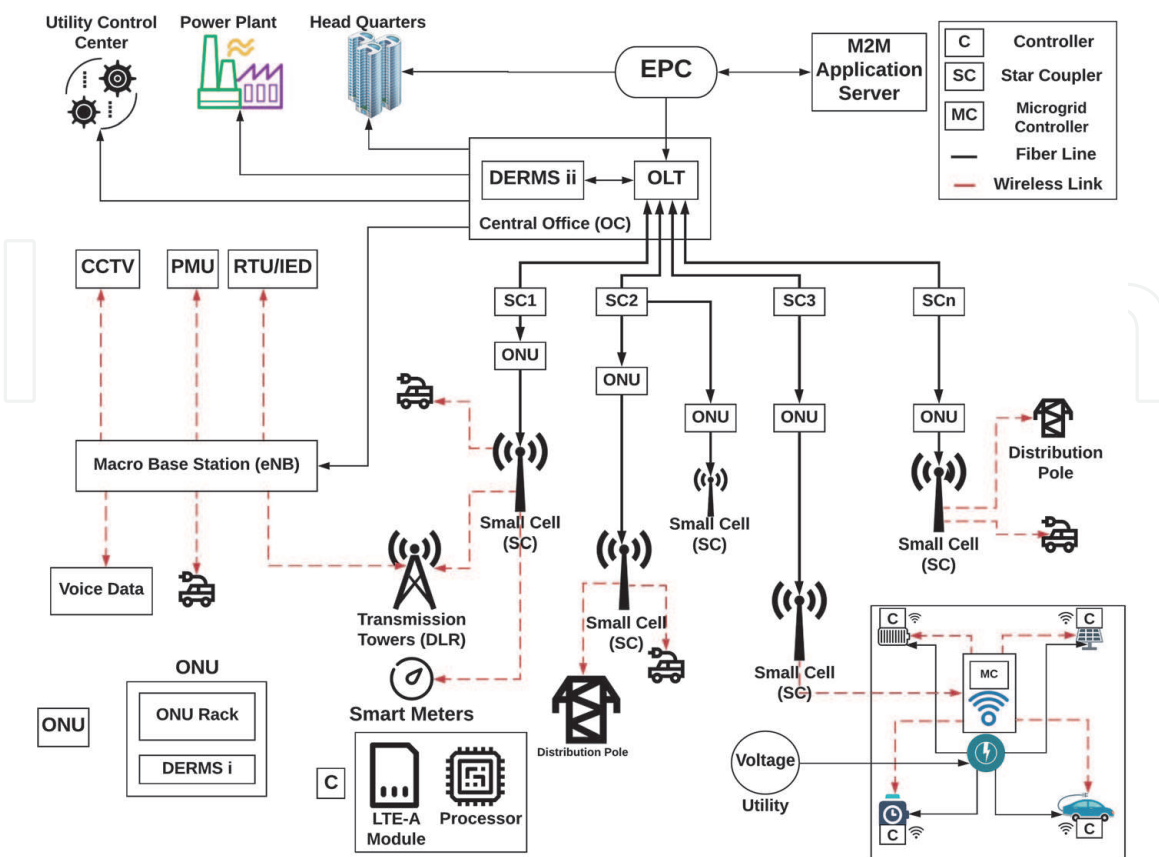

Figure 2.
The schematic diagram of the proposed architecture.

through the SC serving these constellations and/or through direct M2M communications if they are positioned inside the acceptable contiguity distance identified by LTE-A standards. The received monitoring and control data is processed by $DERMS_i$ manager and returns the commands to the group of MGCC. While the second higher level $DERMS_{ii}$ central manager is positioned with the (OLT) at the central office (CO), which collects the grid's control traffic from the first level $DERMS_i$ managers through the fiber dependent PON infrastructure for higher reliability. The received control data are processed by the $DERMS_{ii}$ central manager and then broadcasts the commands to the $DERMS_i$ manager. $DERMS_{ii}$ may also forward these data and/or after processing it to the utility data and the control center(s). The direct wired fiber-dependent communications between the $DERMS_{ii}$ central manager and the first level $DERMS_i$ manager is significantly highly reliable, which guarantee swift delivery of the critical mission control data. It is noted that MGCCs and $DERMS_{ii}$ can decide to bypass the first level $DERMS_i$ managers and communicate directly through the PON and HetNet. Because the $DERMS_{ii}$ central manager has a universal knowledge of the entire local distribution grid's portion assets inside this specified domestic zone, it can manage, and control the whole distribution grid applications in this local portion. For example, efficient energy management and optimization models development, advanced metering, demand response (DR), smart electric Vehicle (EV) charging, and distributed generation. It is noted that the anticipated architecture supports the flexibility of supporting such management and control operations either in an entirely integrated method, an entirely distributed method, or a hybrid method that uses both approaches.

Additionally, the CO can accommodate numerous OLTs, and each OLT can operate more than one PON and, hence, at least one $DERMS_{ii}$ central manager may be accommodated at the CO. Domestic NAN/FAN architecture may be extended to a worldwide scale widening from NAN to MAN to WAN to a universal would span several interconnected COs. At each CO, all instantaneous monitoring and control traffic will be efficiently processed and forwarded by a group of $DERMS_{ii}$ central manager and then collected from all communication endpoints, which are served by several PONs and HetNets. The instantaneous knowledge of the whole universal grid status and assets will be identified significantly by the utility data and control centers. This provides the power grid with the potential of self-healing capability, efficient resilience, reliability, and survivability mechanisms.

3.2 PON-based SC backhaul infrastructure

A new challenge for the backhaul is introduced by an extensive implementation of SC, which must support connections at enough capacity and assured quality of service (QoS). The quantity of SC sites in a specific macrocell zone can grow up to numerous hundreds (e.g., large city center). All SC necessitate fast backhaul connection. Consequently, the connection implementation between the mobile CN and the SC BSs becomes challenging. The key challenge is how to provide cost-effective, scalable and flexible mobile backhaul solution to connect a massive number of SCs to the mobile CN. To tackle the backhauling challenge, I propose and utilize an economical fiber-based SC backhaul infrastructure, which exploits the current fiber facilities connected to a PON-based FTTN/FTTH domestic access network [12–14]. Due to the distribution of the current fiber assets, the projected PON-based backhaul architecture, in which the SCs are housed with the present FTTN remote units (ONUs) is much more cost-effective than traditional cost prohibitive P2P fiber backhaul schemes.

The HetNet backhaul RAN architecture could be developed from the PON architecture essentially by superimposing the SCs with the ONUs, while exploiting

the available present fiber backhaul over dark fibers and operated ONUs linked with the PON-dependent FTTx domestic access network. The SCs is implemented using a low-height (2–4 m) antenna affixed on or adjacent to the ONU (e.g., near to a light post). The CO accommodates the OLT, which links with metro/EPC through the metro terminal equipment located at the CO. The PON and LTE-A based SC systems are autonomously operated where the HetNet RAN system is expected to have its own management and control functions independently from the PON. Each SC is expected to be positioned with an ONU or treated as a generic user attached to it. The ONU and SC can be communicated as long as they support a common standard interface. Consequently, the OLT, EPC, ONUs, and SCs, are completely anticipated to provide a common standard interface (e.g., 802.3ah Ethernet interface). [13, 14]. Each ONU is expected to have two diverse Ethernet port ranges; the first port range will support wired users, while the second one will support wireless M2M grid traffic. The port ranges will be used by the ONUs to identify and differentiate between wireless M2M grid traffic versus typical PON fixed users.

A tight coordination and cooperation between the utilities and telecom carriers or preferably an integrated power-grid-communication network is required in order to reap the full benefits of such hybrid architecture. Because power and communications companies are generally separate commercial enterprises in North America and Europe, implementing this vision will require considerable government and large-vendor effort to encourage various enterprises to cooperate. In any case, utilizing public, commercial mobile and FTTN/FTTH residential access networks for smart grid requires tight coordination and cooperation between both parties. Given the utmost importance of the power grid for the welfare and national security of the nation, integrating these two sectors should be given highest priority.

3.3 Addressing the interoperability challenge

The system is called interoperable when the information and communications systems are capable of sharing and interchanging data as well as to be integrated with the other systems and applications. Information interoperability has three types: (1) Morphological interoperability: this type of interoperability guarantees that the same data has an identical structure and similar format. In addition, it is referred to as a structural interoperability. (2) Semantic Interoperability: It allows different types of information systems and applications to exchange information based on predetermined conditions. It ensures the message is received at the user end. (3) Syntactic Interoperability: This type of interoperability did as same as the Semantic interoperability, however, it is not guaranteeing that the receiver received the message [15].

LTE-A equipped M2M module is implemented in every grid asset (Components, controllers, appliances, equipment, and etc.), as LTE-A is an all IP-based network. Therefore, telecommunications among the whole grid assets depend on an IP-dependent communications protocol. The E2E interoperability among billions of distributed multiple vendor's communication devices is facilitated through the whole distribution grid. This is substantial as the complex several vendors' interoperability standard challenge is persuasively tackled and reduced to a central commonly customary specific protocol – the Internet Protocol (IP), the core protocol of the public Internet. Because IP is the global dominant network protocol, most of the commercially available software and hardware systems are capable of handling IP traffic, hence making IP the logical choice for most networking applications including the power grid of the future [3].

4. The long-term model

The second long-term model as depicted in **Figure 3** is depending on the developing concept of 5G-network slicing, which is permitted by contemporary swift networking progresses and improvements in mobile edge computing and storage capabilities, software-defined networking (SDN), and network functions virtualization (NFV). An extensive distinct IoT vertical industries (applications) are anticipated to be supported by 5G. Each of which have its own distinctive collection of performance and service necessities, MTC, and numerous virtual networks. Each virtual network is customized for a given applications and must be created on the top of the common physical 5G infrastructure. Each logical network is denoted as a 5G network slice. Each 5G network slice comprises of a mix of dedicated resource requests. For example, radio frequency spectrum, network equipment, and VNF. Thus, each slice will have its own virtual mobile CN as well as its own RAN functionalities. All network slices would be different and independently configured. Thus, under the second model, the 5G-network slice that is assigned to the smart grid must:

1. have its own set of resources and functionalities
2. totally isolated from all other network slices
3. Fully managed and controlled by the utility or a third-party provider independent of all other network slices.

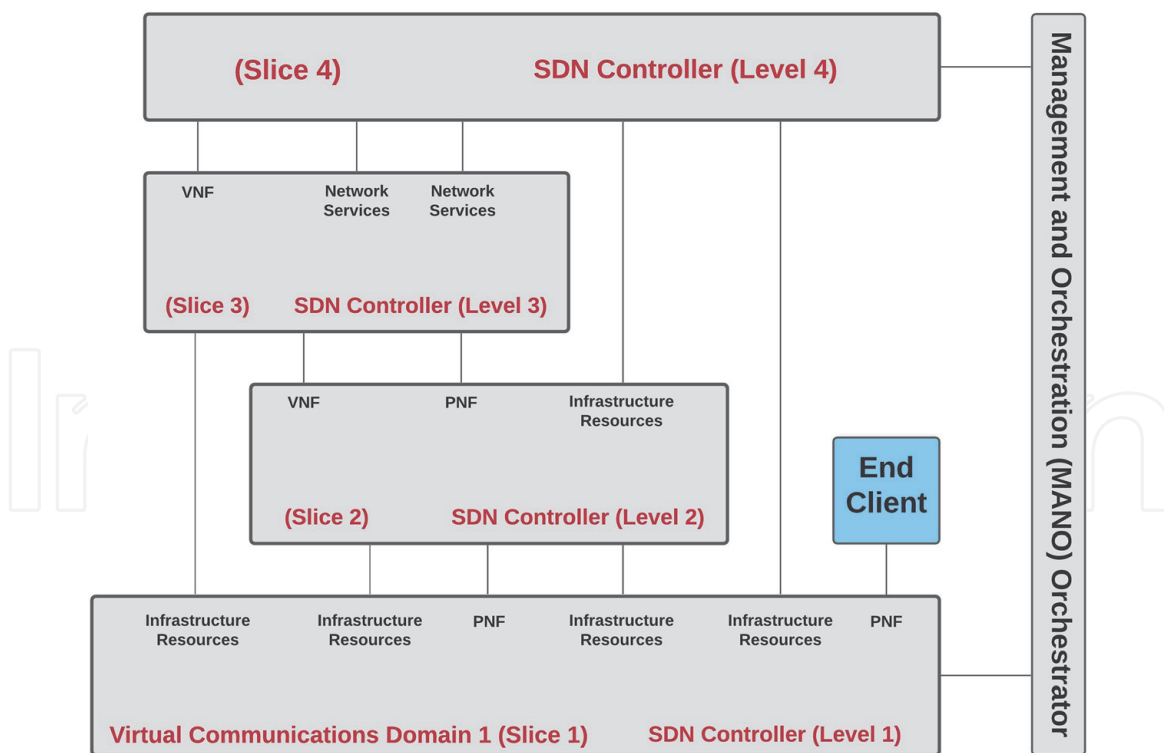

Figure 3.
 Multiple hierarchical arranged SDN controllers.

5. Conclusion

This work has assessed and investigated the prospective of the emerging 5G cellular technologies capabilities to be incorporated with the power grid to allow the

accomplishment of an actually smart grid. Based on time-to-market strategy, we have proposed two different 5G-based commercial and architectural models that enable a really congregated power grid-ICT infrastructure, denoted as a near-term model and a long-term model. Exactly, this work has formulated a proficient universal hybrid fiber/5G- based converged grid-communication networking infrastructure to facilitate effective and extensive DERs implementation. The salient feature of the proposed architecture is that it facilitates and ensures seamless end-to-end interoperability among the millions of multiple vendors' communication devices distributed throughout the entire distribution grid. Furthermore, it enables the development of the assessment tools and practices, which can be used as initial guidelines by utilities and/or grid operators, to specify ICT requirements needed to support full advanced distribution automation, including wide-scale integration of DERs and enhanced system resilience.

Conflict of interest

“The authors declare no conflict of interest.”

IntechOpen

Author details

Ahmed Y. Hassebo
Purdue University Northwest, Westville, IN, USA

*Address all correspondence to: ahassebo@pnw.edu

IntechOpen

© 2021 The Author(s). Licensee IntechOpen. This chapter is distributed under the terms of the Creative Commons Attribution License (<http://creativecommons.org/licenses/by/3.0>), which permits unrestricted use, distribution, and reproduction in any medium, provided the original work is properly cited. 

References

- [1] R. Walton, June 2015. [Online]. Available: https://www.utilitydive.com/editors/robert/?month_filter_value=062015&scroll-top=300. [Accessed 30 September 2019].
- [2] Pacific Northwest National Laboratory, "The Emerging Interdependence of the Electric Power Grid & Information and Communication Technology".
- [3] G. Alliance, "The Future of the Grid – Evolving to Meet America's Needs".
- [4] A. Y. Hassebo, Commercial 4G LTE Cellular Networks for Supporting Emerging Mission-Critical IoT Applications, New York: The City College of New York, ProQuest Dissertations Publishing, 2018. 13425690, 2018.
- [5] R. S. W. H. H. J. a. J. K. J. Kassakian, "The Future of the Electric Grid: An Interdisciplinary MIT Study," 2011.
- [6] X. Lin, J. G. Andrews, A. Ghosh and a. R. Ratasuk, "An Overview of 3GPP Device-to-Device Proximity Service," *IEEE Communications Magazine*, vol. 52, no. 4, pp. 40 - 48, 2014.
- [7] D. Feng, L. Lu, Y. Yuan-Wu, G. Y. Li, S. Li and a. G. Feng, "Device-to-Device Communications in Cellular Networks," *IEEE Communications Magazine*, vol. 52, no. 4, pp. 2482 - 2489, 2014.
- [8] A. Hassebo, A. A. Mohamed, R. Dorsinville and M. A. Ali, "5G-based Converged Electric Power Grid and ICT Infrastructure," in *2018 IEEE 5G World Forum (5GWF)*, Silicon Valley, CA, USA, 2018.
- [9] L. Thrybom, *5G and Energy*.
- [10] K. Samdanis, S. Wright, A. Banchs, A. Capone, M. Ulema and K. Obana, "5G Network slicing: Concepts, Principles, and Architectures," *IEEE Communication Magazine*, vol. 55, no. 5, pp. 70 - 71, 2017.
- [11] A. Hassebo, M. Obaidat and a. M. A. Ali, "Commercial 4G LTE cellular networks for supporting emerging IoT applications," in *2018 Advances in Science and Engineering Technology International Conferences (ASET)*, Dubai, UAE, 2018.
- [12] C. Ranaweera, M. G. C. Resende, K. Reichmann, P. Iannone, P. Henry, B. Kim, P. Magill, K. N. Oikonomou, R. K. Sinha and S. Woodward, "Design and Optimization of Fiber Optic Small-Cell Backhaul Based on an Existing Fiber-to-the node residential access node," *IEEE communication magazine*, vol. 51, no. 9, pp. 62 - 69, 2013.
- [13] H. Shahab, S. Zaidi and M. A. Ali, "A Novel Intelligent Mobile Backhaul RAN Architecture for Emerging Heterogeneous Networks," in *Proceedings of IEEE GLOBECOM*, Austin, TX, 2014.
- [14] M. A. Ali, G. Ellinas, H. Erkan, A. Hadjiantonis and R. Dorsinville, "On the Vision of Complete Fixed-Mobile Convergence," (INVITED PAPER); Special issue on very high throughput wireless over fiber technologies and applications), *Journal of Lightwave Technology*, vol. 28, no. 16, pp. 2343 - 2357, 2010.
- [15] I. H. M. Azam, The Role of Interoperability in ehealth, School of Computing, 2009.