

Factors Affecting the Competitiveness of Logistics Service Enterprises: A Case Study of Dong Nai Province

Nguyen Viet Hung¹, Phan Thanh Tam²

^{1,2}Lac Hong University (LHU), Dong Nai province, Vietnam

¹viet_phuongnam@yahoo.com

²Corresponding author: phthtam74@gmail.com

Abstract - Competitiveness of enterprises can maintain and improve competitive advantage in consuming products or services. Besides, enterprises expanded their consumption network through surveying experiences in the logistics service sector. Therefore, the authors surveyed 30 logistics service enterprises with 500 customers. The results showed five factors that affected the competitiveness of logistics service enterprises of Dong Nai Province with 1% significance. Finally, the article draws some recommendations to help enterprises improve the competitiveness of logistics services.

Keywords: Competitiveness, Logistics, Service Enterprises, and LHU.

1. Introduction

Logistics makes an essential contribution to the distribution of goods from production to the consumer and is a bridge for global trade [4]. Today's logistics activities are not only associated with logistics, freight forwarding, but also planning, arranging the flow of raw materials from suppliers to manufacturers, and then transferring goods from production to the end consumer, creating a link in the whole society according to optimization options, reducing circulation and storage costs [9].

Besides the above results, our country's logistics industry is also facing many difficulties and challenges. Specifically, many researchers studied competitiveness.

Many authorities, managers, and businesses are not fully aware of the importance of the industry. Enterprises that participated in providing logistics services are primarily small and medium. The enterprises' financial capacity is not large, so the organizational structure is simple, not specialized, it

cannot organize representative offices in foreign countries, and limited information sources. Besides, management agencies and businesses have not yet thoroughly evaluated logistics and supply chains' management, especially the remaining steps from domestic ports to end-consumers [5], [36].

The current legal framework governing logistics activities is no longer appropriate, lacking necessary institutions in the international logistics field. Therefore, the logistics service market still lacks transparency, competition is not healthy, and has not created favorable conditions for sustainable development for the industry.

2. Literature Review

2.1 The competitiveness of enterprise (COM)

A company's competitiveness is seen as its ability to design, produce and deliver products to the market with excellent price and quality, and competitiveness [32], [8]. The business competition is its ability to gain and maintain market share in the market with a sure profit.

It is argued that competitiveness is an enterprise's ability to supply products in different markets, regardless of where the firm is located [30], [6]. Besides, firm competitiveness is its ability to produce a product at an average variable cost lower than its market price, which means which firm can have consequences of similar quality as that of another enterprise but at a lower cost is considered highly competitive [11], [27].

2.2 Financial capacity of the business (FCB)

The business's financial capacity is shown in the size of capital, mobilizing and using money effectively, and financial management capacity in the enterprise [7], [23]. First of all, financial capability is tied to capital - an essential factor of production and input.

Therefore, efficient use of money, fast capital turnover dramatically reduces capital costs and reduces product costs, significantly affecting business results and competitiveness of the business in the logistics industry [21], [29].

Besides, the timely capital mobilization to meet materials, raw materials, hire labor, purchase equipment, technology, organize the retail system. etc. Thus, financial capacity reflects the business's economic strength, which is the first and must-have requirement if you want your business to succeed in business and improve competitiveness [31], [25]. Based on the concept mentioned above and studies, authors give hypothesis H1 following:

Hypothesis H1: Financial capacity of the business (FCB) positively impacts the competitiveness of logistics service enterprises of Dong Nai Province.

2.3 Corporate governance capacity (CGC)

The management team's qualifications: This team's qualification is not merely the educational level but also the vast and complex knowledge in many fields related to its business activities [19], [25]. Business, domestic and international law, market, industry, knowledge of society, and humanities [3], [10].

Management qualifications and business capabilities are also shown in business strategy planning, business planning, operation management [1], [13]. Management capacity is also reflected in personnel replacement speed before changes [2], [15]. This factor has significant implications for improving business performance in the short and long term and substantially impacts businesses' competitiveness [12], [14]. Based on the concept mentioned above and studies, authors give hypothesis H2 following:

Hypothesis H2: Corporate governance capacity (CGC) positively impacts the competitiveness of logistics service enterprises of Dong Nai Province.

2.4 Technological capacity of the business (TCB)

Technology is a critical factor, significantly affecting enterprises' competitiveness [16], [22]. Appropriate technology allows shortening production time, reducing energy consumption, increasing productivity, lowering product costs, improving product quality, and creating a competitive advantage over its products/services [18], [28].

The ability to apply technology significantly affects the competitiveness of businesses [20], [33]. Production technology is a crucial factor, considerably affecting the competitiveness of enterprises. Appropriate technology allows shortening production time, reducing energy consumption, increasing productivity, lowering costs, improving product quality/services [24], [34]. Based on the concept as mentioned earlier and studies, authors give hypothesis H3 following:

Hypothesis H3: The business (TCB) Technological capacity positively impacts the competitiveness of the logistics service enterprises of Dong Nai Province.

2.5 Marketing capacity of the business (MAR)

The marketing capacity of a business is the ability to grasp market demand, the ability to implement 4P (Product, Place, Price, Promotion) strategies in marketing activities [26], [30]. Marketing ability directly impacts the production/services and consumption of products, meeting customer needs, contributing to increasing revenue, increasing product market share, and improving enterprises' position [31], [35]. The marketing capabilities are demonstrated by continually monitoring and responding to changes, including customers, competitors, and the macro-environment [37], [23].

Marketing capacity helps businesses implement marketing programs more effectively. This capacity allows companies to capture changes in products and services appropriate in response to this change. Therefore, this capacity is associated with the business's creative power [2], [16]. Based on the concept as mentioned above and studies, authors give hypothesis H4 following:

Hypothesis H4: The business's marketing capacity (MAR) positively impacts the competitiveness of the logistics service enterprises of Dong Nai Province.

2.6 Brand capacity of the business (BRA)

A brand's description of value includes a business's ability to add value to its products and services. This added value can be used to help the business change prices. Through these factors, the above values show that brand name is also a factor contributing significantly to the business's competitiveness.

A brand is a combination of all the impressions received from customers and consumers by the distinct position based on the functional and emotional benefits perceived. Therefore, the brand is

not only a word but also a passion. The commitment and a promise that needs to be fulfilled every day also affirm the brand as a set of tangible and intangible properties, symbolized by a trading name that, if managed in the right direction, will create influence and value [23], [15].

Financial literacy is also related to mastering economic principles and concepts such as financial planning, compounding, debt management, practical saving techniques, and the time value of money. Financial knowledge positively influences buying life insurance [27], [35]. Based on the concept mentioned

above and studies, authors give hypothesis H5 following:

Hypothesis H5: The business (BRA) Brand capacity positively impacts the competitiveness of the logistics service enterprises of Dong Nai Province.

A research model for factors affecting the competitiveness of logistics service enterprises of Dong Nai Province following:

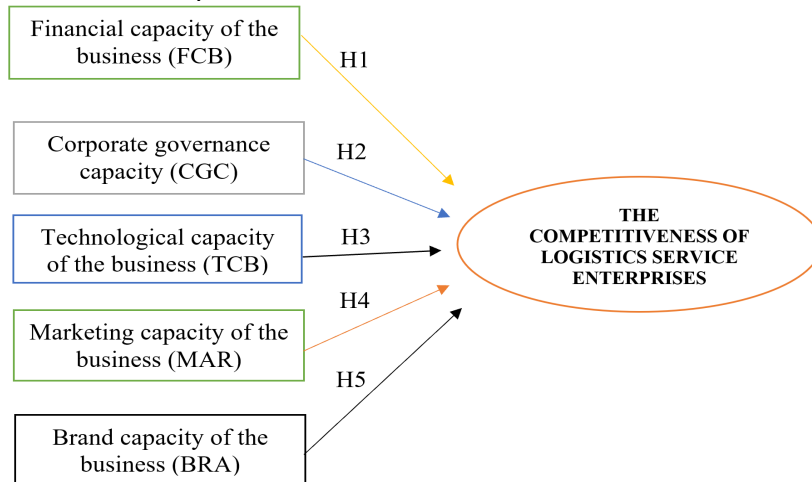

(Source: Researchers discovered)

Figure 1. A research model for factors affecting the competitiveness of logistics service enterprises of Dong Nai Province

3. Methods of Research

The research method of the topic is a combination of qualitative research methods and quantitative research methods:

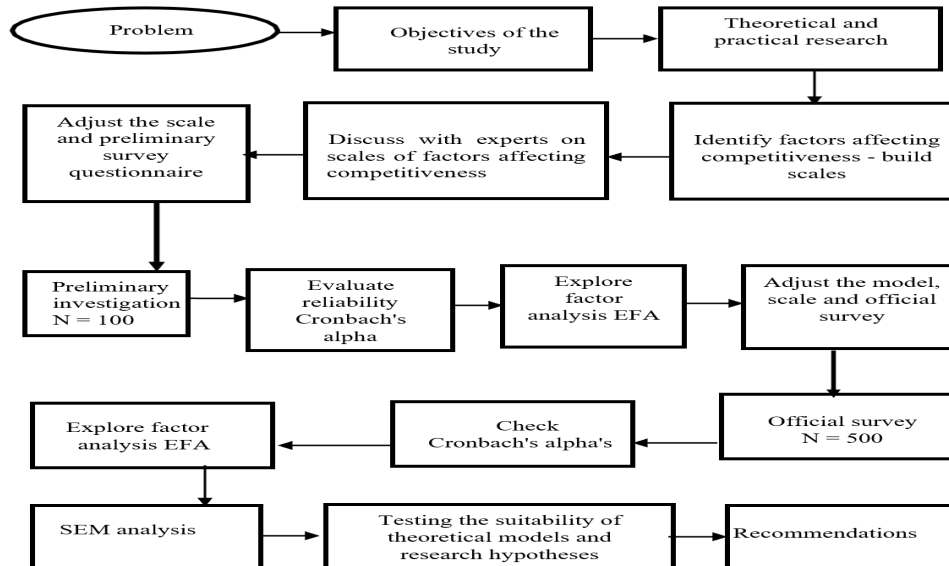

(Source: Researchers proposed)

Figure 2. A research model for factors affecting the competitiveness of logistics service enterprises of Dong Nai Province

This research is done according to the mixed method: Combining qualitative research and quantitative research. The quantitative analysis aims to collect data to test scientific theories (test models and hypotheses) deduced from existing approaches. The authors research qualitatively to explain the quantitative results that the quantitative numbers cannot explain. So the author uses two [17].

Qualitative research is to identify factors affecting enterprises' competitiveness based on the concepts of competitiveness, theoretical models of corporate competitiveness, and Competitiveness scores that are synthesized and arranged systematically by the author. Besides, the authors applied research models and scales of factors affecting the competitiveness of enterprises. After studying the document, the author uses the expert method by discussing with 15 experts at the Dong Nai province universities to adjust the scale to ensure the correctness of the proposed model. Measure to suit the business.

4. Research Results

Testing Cronbach's alpha for factors affecting the competitiveness of logistics service enterprises of Dong Nai Province following:

Table 1. Testing of Cronbach's alpha for the competitiveness of logistics service enterprises

Items		Cronbach's alpha
Financial capacity of the business (FCB)		0.945
FCB1	Enterprises with healthy financial activities	0.912
FCB2	Enterprises can quickly mobilize capital	0.938
FCB3	Enterprise with annual profit is continually increasing	0.945
FCB4	The enterprise has good solvency	0.916
Corporate governance capacity (CGC)		0.861
CGC1	Business leaders have extensive and deep knowledge in their professional fields	0.814
CGC2	Business leaders are on a par with their duties	0.819
CGC3	The enterprise has an appropriate organizational model	0.847
CGC4	The enterprise allocates resources reasonably	0.811
The technological capacity of the business (TCB)		0.902
TCB1	Enterprise has a modern technology system	0.870
TCB2	The scale of service to meet customer needs	0.830
TCB3	Enterprises applying information technology to all customers	0.879
Marketing capacity of the business (MAR)		0.951
MAR1	The business has a good marketing strategy	0.929
MAR2	The business has a good marketing team	0.944
MAR3	The enterprise determines the appropriate target market	0.945
MAR4	Enterprises always closely follow competitors' moves	0.926
The brand capacity of the business (BRA)		0.947
BRA1	The customers evaluate the enterprise with good service quality	0.924
BRA2	The customers evaluate that the business has reasonable prices	0.945
BRA3	The customers rated the enterprise well in terms of environmental friendliness	0.936
BRA4	Customers value the business innovation well	0.918
The competitiveness of enterprise (COM)		0.862
COM1	Good business orientation	0.845
COM2	The creative capacity of the business	0.786
COM3	Service organization capacity of the enterprise	0.861
COM4	Businesses respond well to customers' needs	0.797

Table 1 showed that Synthesize research on enterprise competitiveness, based on background theory, previous research models, and results, finds the above

Quantitative research: Includes preliminary quantitative research and formal quantitative research conducted as soon as the questionnaire is revised. The form of information collection is the direct interview and sending the questionnaire in advance to the interviewee. Collected data were handled by statistical software SPSS 20.0. and Amos. Authors are to save money and time; the report used survey sampling to gather data from 500 customers related to logistics service enterprises of Dong Nai Province, but 485 samples were processed, leaving 15 samples unprocessed [17].

The authors applied SPSS 20.0 and Amos tools to measure Cronbach's Alpha's trust coefficient, EFA: explore factor analysis, confirmation factor analysis (CFA), and structural equation modeling (SEM) for the scales' reliability. Finally, the writers gave suggestions [17].

(Source: Researchers proposed by SPSS 20.0) research gaps. The authors have incorporated the issues mentioned above. The authors have developed research hypotheses and proposed research models of

factors affecting the competitiveness of logistics service businesses in Dong Nai province. Besides, results showed that all of Cronbach's alpha is more than 6.0. This article applied a quantitative research method with the help of a small qualitative study. First of all, the authors' group conducted in-depth interviews with 15 experts.

The authors then stem from the research objective. The author conducts document research and previous studies to outline expert interviews and group discussions to establish theoretical and design research models - preliminary investigation questionnaire.

Also, from the synthesis of these research achievements to find research gaps to orient the research topic. On that basis, the authors proposed to research theoretical model. Besides, when studying documents to prove that the concepts put into the model have been studied and tested in countries worldwide. Qualitative research to explore research models and build scale in this study is consistent with local characteristics.

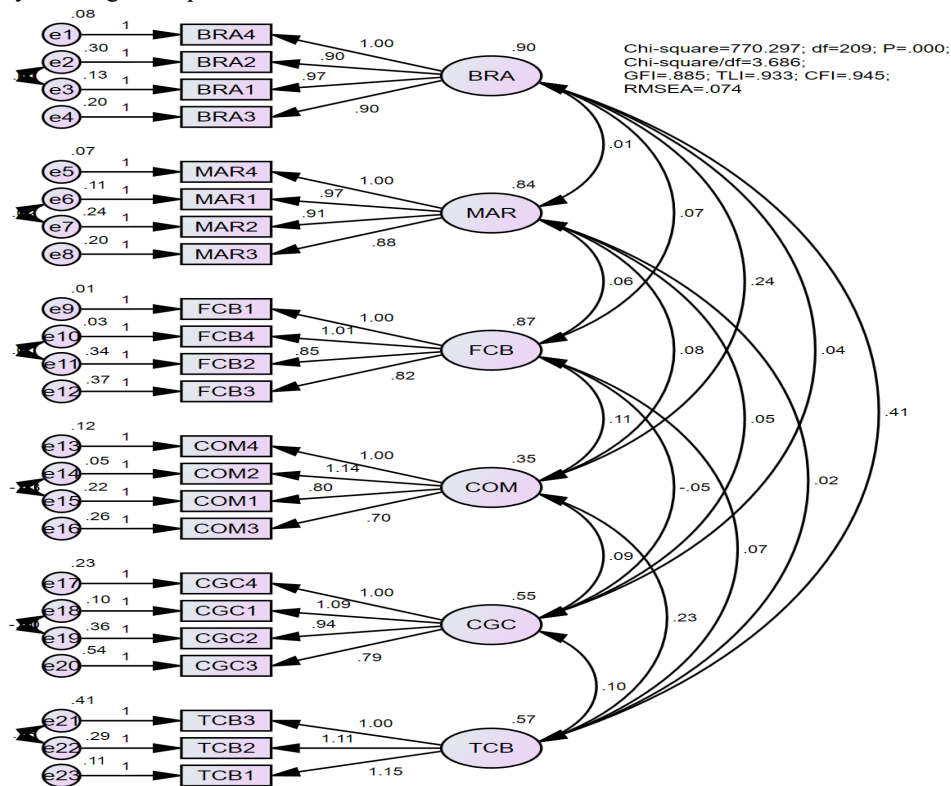

(Source: Data processed by SPSS 20.0 and Amos)

Figure 2. Testing CFA for factors affecting the competitiveness of logistics service enterprises of Dong Nai Province

Table 2. Testing coefficients for factors affecting the competitiveness of logistics service enterprises of Dong Nai Province

Relationships	Unstandardized Estimate	Standardized Estimate	SE.	CR.	P	Hypothesis
COM <--- FCB	0.058	0.126	0.018	3.143	0.002	Accepted
COM <--- CGC	0.063	0.119	0.023	2.702	0.007	Accepted
COM <--- MAR	0.061	0.122	0.021	2.893	0.004	Accepted
COM <--- BRA	0.104	0.208	0.026	3.935	***	Accepted
COM <--- TCB	0.218	0.369	0.035	6.222	***	Accepted

(Source: Data processed by SPSS 20.0, Amos)

Table 2 showed that five factors affect Dong Nai Province's logistics service enterprises' competitiveness with a significance level of 0.01. The author has analyzed five factors affecting the competitiveness of enterprises, including 23 observed

variables. The authors extracted analysis results into five factors with the total extracted variance of 81.303% (> 50%), the male scale accepted. KMO coefficient = 0.817 in the range of 0.5 ≤ KMO ≤ 1, factor analysis is appropriate. Bartlett testing with Sig.

= 0.000 represents a high level of significance. Factor loading of all observed variables is more significant than 0.5 accepted values.

Results showed that the SEM assessment had five factors affecting the competitiveness of logistics service enterprises of Dong Nai Province with a

significance level of 0.01. Since the official research model has no change than the initially proposed research model, the authors did not remove the reliability test variables and the discovery factor analysis. The author's official measure is still 23 variables in the model.

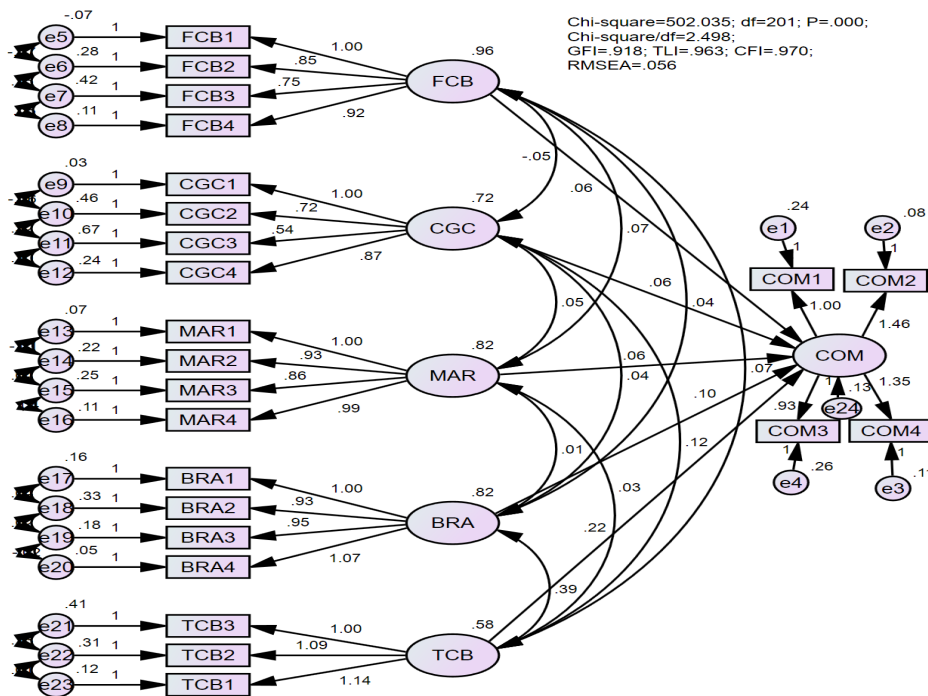

(Source: Data processed by SPSS 20.0, Amos)

Figure 3. Testing SEM for factors affecting the competitiveness of logistics service enterprises of Dong Nai Province

Table 3. Testing coefficients of Bootstrap (N = 5.000) for factors affecting the competitiveness of logistics service enterprises of Dong Nai Province

Parameter	SE	SE-SE	Mean	Bias	SE-Bias
COM <--- FCB	0.022	0.000	0.061	0.003	0.000
COM <--- CGC	0.024	0.000	0.060	-0.003	0.001
COM <--- MAR	0.023	0.000	0.060	-0.001	0.002
COM <--- BRA	0.031	0.000	0.101	-0.003	0.001
COM <--- TCB	0.041	0.001	0.223	0.004	0.003

(Source: Data processed by SPSS 20.0, Amos)

Table 3 showed that the bootstrap test results are very good with a sample of 5.000 customers. These results indicated that five factors affected the competitiveness of logistics service enterprises of Dong Nai Province with a significance level of 0.01. This study shows that the research concept scales are satisfactory; from the preliminary research results, the author has not adjusted the model and built a scale for the official study. Finally, the official research results serve as the basis for the analysis and assessment of competitiveness. This result is also the basis for the authors to propose governance implications.

5. Conclusions

This study has identified factors affecting competitiveness, added to the scale of factors affecting the competitiveness of logistics service businesses in Dong Nai province. In this study, there are six research concepts. The scale assessment results through Cronbach's alpha and the analysis of discovery factors EFA show that the scales are satisfactory in terms of value. They have measured the impact of these factors on the competitiveness of the business. The test results show that the research model's compatibility with

81,303% descriptive data and the acceptance of the research model's hypotheses.

The results of this study have identified five factors affecting the competitiveness of enterprises, including 1) Factor of Financial capacity of the business (FCB); 2) Corporate governance capacity (CGC); 3) Technological capacity of the business (TCB); 4) Marketing capacity of the business (MAR); 5) Brand capacity of the business (BRA). The technological capacity of the business (TCB) factor has the most substantial influence (0.369). Five factors are entirely consistent with the current competitive trend of logistics service businesses.

Besides, the research has developed and tested the scale of factors affecting the competitiveness of logistics service businesses in Dong Nai province. The results showed that the model and the scale of factors affecting competitiveness are satisfactory and have high reliability.

Therefore, the research results will contribute to enriching the scale of factors affecting the competitiveness of enterprises. Simultaneously, the research results have also answered research questions, specifying factors affecting the competitiveness of logistics service businesses as a basis for proposing governance implications.

6. Policy implications

(1) Use effectively and improve current technology capacity in service provision of enterprises. Businesses need to use effectively and enhance technology's power because it is the decisive factor to productivity, quality, and service costs. Meanwhile, technology use efficiency depends significantly on production organization, human resources arrangement, and exploitation time. Production and business services are very seasonal, so service businesses here need to allocate human resources and rationally exploit technology to ensure effective use. Enterprises need to renew technology equipment quickly. Enterprises need to optimize the combination of resources to achieve high efficiency.

(2) Enterprises need to establish, mobilize, and use effective capital sources for their operations in the short and long term. Leaders must control the finances of the business. To do that, companies need to meticulously analyze and plan a specific financial for each work block for orders, business plans for each production time of the year, sourcing sources such as capital. Enterprises must calculate carefully to mobilize and use the money to bring high efficiency and avoid risks. Enterprises also need to make a habit of really relying on legal advice from lawyers - people who are knowledgeable about international business law can assist them in contractual terms.

(3) Branding businesses need to go hand in hand with brand protection. Therefore, the registration of industrial property protection, complete trademark registration is vital and should be respected. In parallel with trademark registration, it is essential to expand market share, improve the quality of goods and services after sales to consolidate and increase brand reputation. Besides, it is required to promote domestic and foreign brands, primarily through periodical exhibitions.

Enterprises must creatively build and develop brand names based on their specific services, industry trends, market characteristics, corporate business strategies, and customer emotions row. In Dong Nai, many businesses' brands bear business owners' names, long and difficult to remember. Therefore, companies can organize brand design bidding, hire experts or consult brand experts to have the best brand.

(4) Fostering international business capabilities and enhancing the global competitiveness of businesses. Business managers need to improve their ability to work and transact with foreign companies in international trade, international communication, and cultural differences in business and international practices in the business and industry sectors.

Developing strategic management capacity for managers in enterprises due to lack of strategic vision is one of the causes of long-term development failure. Dong Nai has shown us that there are many cases of service enterprises booming in a few years, then weakening rapidly or even broken, which are shreds of evidence for this. Finally, enterprises should join international exchanges, access world standards, and practices. It is essential to focus on developing critical knowledge and skills such as Foreign language capacity (currently very weak directors of service businesses), cultural, social, and historical basics.

(5) Enterprises should focus on trade promotion activities. First of all, it is necessary to concentrate on advertising activities on newspapers, radio, television, social networking sites, and other media to achieve three objectives: informing, convincing, and reminding customers.

Enterprises need to establish an appropriate distribution channel system to improve market penetration capacity. Enterprises need to reorganize their distribution system based on eliminating the old and unsuitable distribution channels, building a modern distribution system, adapting to the purchase and sale process. Domestic and international. Complete the information system on the business environment, information on the distribution system, and services price.

Besides, enterprises want to the above successful contributions. This study also has certain limitations: restrictions in a research capacity, time, conditions, and funding. This study only focuses on the scope of logistics service enterprises above. in Dong Nai province. Therefore, this conclusion may not be accurate for businesses doing business in Vietnam. This study only focuses on analyzing five factors affecting the competitiveness of service businesses. Therefore, there is a study conducted in the Central Highlands region or the whole country. Many other factors affect the competitiveness of enterprises. It is necessary to have follow-up studies to add additional factors affecting the competitiveness of logistics service businesses.

References

- [1]. Ajitabh, A. and Monmaya, K. (2014). Competitiveness of Firms: Review of Theory, Frameworks, and models. *Singapore Management Review*, 2(6), 45- 61.
- [2]. Anderson, M. J, Terbing. D. K. (2018). Structural equation modeling in proactive: A review and recommended two-step approach. *Psychological Bulletin*, 13(3), 11-23.
- [3]. Barney, J. M. (2017). Firm resources and sustained competitive advantage. *Journal of Management*, 7(1), 99-120.
- [4]. Buckley, P. J, and Prescott, K. (2015). Measures of international competitiveness: A critical survey. *Journal of marketing management*, 4(2), 75-98.
- [5]. Buhalis, D. G. (2015). Marketing competitive destinations of the future. *Tourism Management*, 1(1), 97-116.
- [6]. Chinn, M. D., and Brow, H. T. (2018). New measures of financial openness. *Journal of Comparative Policy Analysis*, 10(4), 9-22.
- [7]. Chow, J. S. (2016). Use of causal models in marketing research: A review. *International journal of research marketing*, 1(3), 81-97.
- [8]. Coevert, V. and Waal, A. V. (2017). The effect of performance management on the organizational results of a bank. *International Journal of productivity and performance management*, 5(6), 39-46.
- [9]. Dayros, G. S. (2017). Closing the Marketing Capabilities Gap. *Journal of Marketing*, 7(5), 83-95.
- [10]. Drabek, Z. F., and Brada. J. R. (2018). Exchange rate regimes and the stability of trade policy in transition economies. *Journal of Comparative Economics*, 2(6), 42-68.
- [11]. Dyer, J. A. (2014). Human capital and learning as a source of sustainable competitive advantage. *Strategic Management Journal*, 2(5), 55-78.
- [12]. Feurer, R, C. (2014). Defining competitiveness: A holistic approach. *Management decision*, 2(2), 49-60.
- [13]. Freiling, J. G. (2014). A Competence-based theory of the firm. *Management journal*, 15(1), 12-22.
- [14]. Goeke, C. R. (2018). Fundamental issues in a competence-based theory of the firm. *International journal of management*, 4(1), 79-106.
- [15]. Gray, B. and Matheson, P. Y. (2018). Developing a better measure of market orientation. *European journal of marketing*, 3(2), 84- 93.
- [16]. Grupp H. S. (2017). The links between competitiveness, Firm innovative activities and public R&D support in Germany: An Empirical Analysis. *Technology analysis and strategic management*, 9(1), 19-33.
- [17]. Hair, J. F. Anderson R. E. Tatham R. L. Black W. C. (2010). *Multivariate data analysis*. Prentice-Hall: Inc.
- [18]. Hine, R. C. (2014). Country-specific factors and the pattern of horizontal and vertical intra-industry trade in the UK. *Review of World Economics*, 3(1), 7-17.
- [19]. Hunman, M. T. and Freeman, J. G. (2019). The organizational mortality: American labor. *American Journal of Sociology*, 9(4), 35-52.
- [20]. Jos, A. D. (2015). Factors influencing the competitiveness of Czech rural small and medium enterprises. Original Paper Agric. *Econ - Czech*, 61(10), 450-460.
- [21]. Jungquist, U. C. (2017). Core competency beyond identification: Presentation of a model. *Management Decision*, 45(3), 93-102.
- [22]. Kohli, A. R. and Jaworski, B. J. (2018). Market orientation: The construct, research propositions, and managerial implication. *Journal of Marketing*, 5(4), 1-18.
- [23]. Kotler, P. and Armstrong, G. (2012). *Principle of marketing*. Pearson Prentice Hall.
- [24]. Krishna, E. G. (2017). A study on factors affecting the competitiveness of SMEs in Malaysia. *International Journal of Academic*, 1(2), 153-167.
- [25]. Loptez, J. A. and Garcia, R. H. (2015). Technology and export behavior: a resource-based view approach. *International Business Review*, 4(5), 53-67.
- [26]. Markham, C. H., and Michael, L. T. (2015). National factor effects on firm competitiveness and innovation. *Competitiveness Review*, 25(4), 392-409.

- [27]. Mehvish, H. G. and Azeem, M. S. (2019). Market analysis for Islamic and conventional banks: Comparative study from Pakistan. *Economics and Finance Review*, 1(10), 55-64.
- [28]. Rugman, A. M. (2015). Developing international competitiveness: the five partners. *Business Quarterly of Journal*, 5(8), 60-72.
- [29]. Samarque, E. F. (2015). Identifying key activities in banking firms: A competence based analysis. *International Management and Business Review*, 7(1), 9-17.
- [30]. Sorbett, C. N. and Wassenhove, D. (2016). Does it Trade off? What trade-offs? Competency and competitiveness in manufacturing. *California management review*, 5(4), 17-22.
- [31]. Srant, R. M. (2018). Contemporary strategy analysis: concepts. Cambridge: *California Management Review*, 3(3), 13-23.
- [32]. Subbard, G. Z., and Jonhson, L. R. (2008). Rethinking traditional value chain logic. *International journal management and business*, 4(2), 10-29.
- [33]. Tassan, S. N. (2016). Determinants of market competitiveness in the environmentally sustainable tourism industry. *Journal of travel research*, 8(3), 39-45.
- [34]. Wine, R. D., and Philips, P. V. (2015). Performance comparisons of hotels in china. *International journal of hospitality management*, 4(1), 57-73.
- [35]. Wofstede, G. C. (2013). Cultural constraints in management theories. *Academy of Management Executive*, 1(1), 8-14.
- [36]. Wuan, T. M. (2016). A study of the relationship between competitiveness and technological innovation capability based on DEA models. *European journal of operational research*, 1(7), 71-86.
- [37]. Yeteraf, M. C. (2018). The cornerstones of competitive advantage: a resource base view. *Strategic managment journal*, 4(3), 79-91.