



## Realization of a Second Harmonic Antenna for Rural Communications\*

Adit Kurniawan<sup>1</sup>, Ahmad Hasyim<sup>1</sup> & Yuyu Wahyu<sup>2</sup>

<sup>1</sup>School of Electrical Engineering and Informatics, Institut Teknologi Bandung  
Jl. Ganesa 10 Bandung 40132, Telp. +62-22-2501661, Fax. +62-22-2534133

<sup>2</sup>Research Centre of Electronics and Telecommunications,  
Indonesian Institute of Science  
Jl. Cisit 21/154 D Bandung 40135, Telp. +62-22-2504660, Fax. +62-22-2504659

**Abstract.** In this research, an active antenna operated at the second harmonic frequency is investigated, and is implemented using microstrip antenna material. The antenna consists of a FET oscillator which plays as a fundamental frequency oscillator and a frequency multiplier, and a patch antenna resonated at the second harmonic frequency as the radiator. A maximum second-harmonic output power can be extracted when the load impedance of the oscillator is optimized both at the fundamental and at the second harmonic frequencies. A rectangular patch antenna is used to radiate the second harmonic output power from the oscillator. The patch impedance is matched resistively at the second harmonic frequency. The patch antenna is fabricated using Duclad 522 microstrip substrates (relative permittivity  $\epsilon_r = 2.5$ ) with a dielectric thickness of 1.57 mm. A GaAs FET AT-8250 transistor is used as an oscillator and a frequency multiplier and acts as the active component. Fundamental frequency is designed at 2.4 GHz band, so that the second harmonic frequency operates at 4.8 GHz band. The frequency is chosen to facilitate and to extend the needs of communications in rural areas using the unlicensed *Industrial Scientific, and Medical* (ISM) band. Operating the communication infrastructures intended for the use at 2.4 GHz band at its second harmonic frequency, is intended to alleviate interference levels at 2.4 GHz.

**Keywords:** *active antenna; harmonic frequency; microstrip patch.*

### Realisasi Antena Harmonik Kedua untuk Komunikasi Daerah Terpencil

**Sari.** Pada penelitian ini, antena yang beroperasi pada frekuensi harmonik kedua dipelajari dan diimplementasikan menggunakan bahan antena mikrostrip. Antena yang dihasilkan terdiri dari sebuah osilator FET yang berfungsi sebagai pembangkit frekuensi fundamental dan pengali frekuensi, serta antena *patch* yang beresonansi pada frekuensi harmonik ke-dua sebagai peradiasi. Daya maksimum pada frekuensi harmonik kedua dapat dihasilkan dengan mengoptimalkan impedansi pada frekuensi fundamental dan frekuensi

---

\* This research is funded by ITB Research Grant no. 0076/K01.03/PL2.1.5/VI/2005.

Received April 2006, Revised September 25<sup>th</sup>, 2006, Accepted for publication September 25<sup>th</sup>, 2006.

harmoniknya. *Patch* persegi digunakan sebagai peradiasi daya pada frekuensi harmonik kedua yang dibangkitkan oleh osilator. Impedansi *patch* disesuaikan secara resistif pada frekuensi harmonik keduanya. Antena *patch* dirancang menggunakan bahan mikrostrip Duclad 522 (permitivitas relatif  $\epsilon_r = 2,5$ ) dengan ketebalan dielektrik 1,57 mm. GaAs FET AT-8250 digunakan sebagai osilator dan pengali frekuensi yang berfungsi sebagai komponen aktif. Frekuensi fundamental dirancang pada pita 2,4 GHz, untuk menghasilkan frekuensi harmonik kedua pada pita 4,8 GHz. Frekuensi ini dipilih untuk memperluas keperluan komunikasi yang menggunakan pita ISM band 2.4 GHz tanpa lisensi. Pengoperasian pita ISM pada frekuensi harmoniknya ditujukan untuk mengurangi tingkat interferensi pada pita 2,4 GHz.

**Kata kunci:** *antenna aktif; frekuensi harmonik; microstrip patch.*

## 1 Introduction

Recent development on antenna engineering is that the antenna or array antenna is now integrated with active component to construct what is called an active antenna. This trend has attracted much attention in producing a compact and conformal design of antennas, as well as in paving the way into new research directions and innovations. Conventional technology uses up converters to translate the frequency into the specified frequency band. However in some cases, particularly in portable applications, compactness of the equipment and peripheral often becomes very important. Integrating up converters with antennas may result in the equipment being more compact and more power-efficient. Further simplification and reduction in system component required to deliver higher frequency transmitter can be done by designing the transmitter that operate at harmonic frequency radiations [1]. This technique, unlike using an up converter, utilizes higher frequency resulted from the design that the transmitter is adjusted to have the resonant frequency at its harmonic radiation. Beam scanning techniques at harmonic frequencies [2]-[3] are also possible to generate a higher frequency radiation. However, this technique requires a more complex design and realization, and therefore is not suitable in practice. To generate a harmonic frequency component, the antenna impedance is designed to be dominant resistive at the specified harmonic frequency and become reactive at fundamental and other unwanted harmonic frequencies [4]. In this work the second harmonic frequency is designed for fundamental frequency of 2.4 GHz in order to generate the output of 4.8 GHz. This antenna can be used to serve the need of communications using wireless local area network (WLAN) technology normally operated at 2.4 GHz frequency band, which has been very crowded and experiencing high interference in some areas.

## 2 Antenna Design and Simulation

The active component of harmonic antenna is implemented using microstrip-based technology. Transmission line is implemented using microstrip line technique. Other components can be mounted on the microstrip patch. Strip line and patch antenna are easy to fabricate using printed circuit technology, which allows a more compact design. In general, strip line is a transmission line of a planar strip of width  $W$  and a ground plane separated by dielectric material of thickness  $h$ , as shown in Figure 1 [5]. The strip line is configured on the top side and the ground plane at the bottom side of the microstrip material as shown in Figure 1, and acts as the transmission media where the electromagnetic wave propagate.

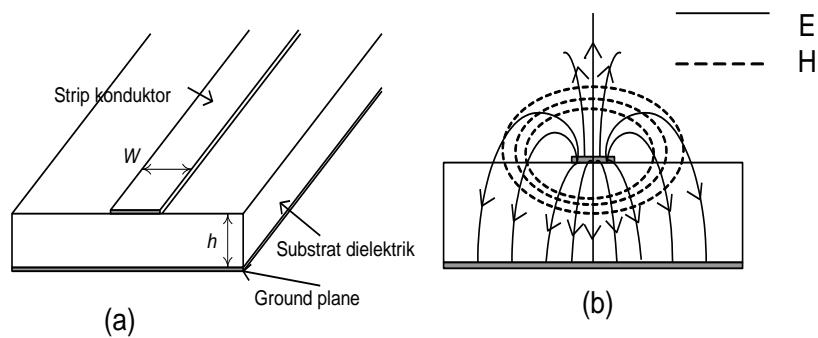

**Figure 1** Microstrip line: (a) Geometric shape, (b) Electric and magnetic field on strip line.

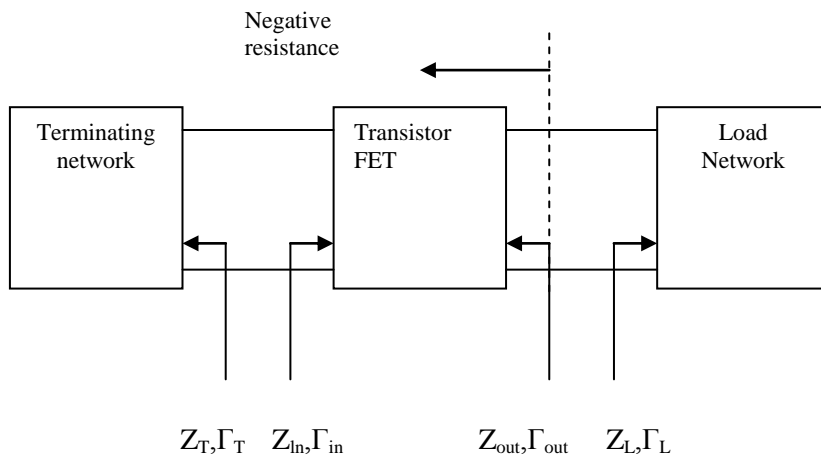
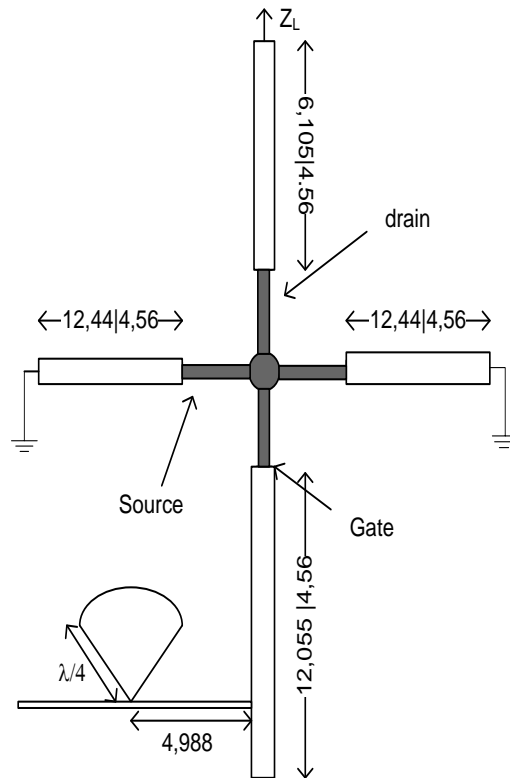

**Figure 2** Negative resistance configuration.

The most common dielectric materials used in the microstrip technique are duroid [6] with relative permittivity  $\epsilon_r = 2.56 \epsilon_o$ , quartz ( $\epsilon_r = 2.78 \epsilon_o$ ), alumina ( $\epsilon = 9.7 \epsilon_o$ ), silicon ( $\epsilon = 11.7 \epsilon_o$ ), teflon ( $\epsilon = 2.56 \epsilon_o$ ), with  $\epsilon_o$  is free space permittivity ( $\epsilon_o = 8.854 \times 10^{-12}$  F/m). In this research, we choose dielad materials to provide a better radiation performance. The harmonic frequency is generated using FET transistor, which is designed in such a way to produce negative resistance characteristics, as described in Figure 2.

The characteristic and parameter of the FET transistor is: GaAsFET AT-8250, with the drain-source voltage  $V_{ds} = 3$  V, and the drain-source current  $I_{ds} = 20$  mA. The  $S$  parameter of the FET transistor on a common source configuration is given by :

$$\begin{aligned} S_{11} &= 0,92 \angle -64^\circ; S_{12} = 0,068 \angle 45^\circ \\ S_{21} &= 3,91 \angle 121^\circ; S_{22} = 0,48 \angle -49^\circ \end{aligned} \quad (1)$$



**Figure 3** Negative resistance oscillator ( $f = 2.441$ GHz).

The negative resistance-based oscillator will generate a maximum output power at harmonic frequencies when the load is made to be pure resistive. Oscillator circuit is fabricated on microstrip dielad 522 material ( $\epsilon_r = 2.5$ ), and the thickness of material  $h = 1.57$  mm as shown in Figure 3. Transistor being used is GaAs FET AT-8250, operated at frequency of 2,4 GHz, drain-source voltage  $V_{ds} = 3$  V, current  $I_{ds} = 20$  mA, and the gate-source voltage  $V_{gs} = 0$ . Antenna design is performed using simulator software, Ansoft Ensemble 7.0, which is based on the method of moment technique (MoM-based software). Figure 3 shows the top view of oscillator circuit at 2.441 GHz with load impedance  $Z_L = 99$  ohm. The width of microstrip line at characteristic impedance of 50 ohm is  $W = 4,56$  mm. For bias circuit an  $R$ -stub (coke) is used to block AC and to pass through DC currents.

The design results show that the  $S$  parameter on the direction of the load ( $|\Gamma_t|$ ) is maximal at the centre frequency. The maximum value of  $|\Gamma_t|$  resulted from the design is 1.238, which occurs at the frequency  $f = 2.435$  GHz. Changing the  $V_{gs}$  will change the oscillating frequency and the output power, i.e. decreasing the  $V_{gs}$  will lower the oscillating frequency and output power.

### 2.1 Realization of Patch Antenna

Figure 4 shows the top view of the two-element patch antenna, which is designed to operate at the second harmonic frequency. The two-element patch antenna is designed to obtain higher gains. The patch antenna acts as the load for the oscillator,  $Z_L$ ; while  $Z_{in}$  is an input impedance of the patch antenna.

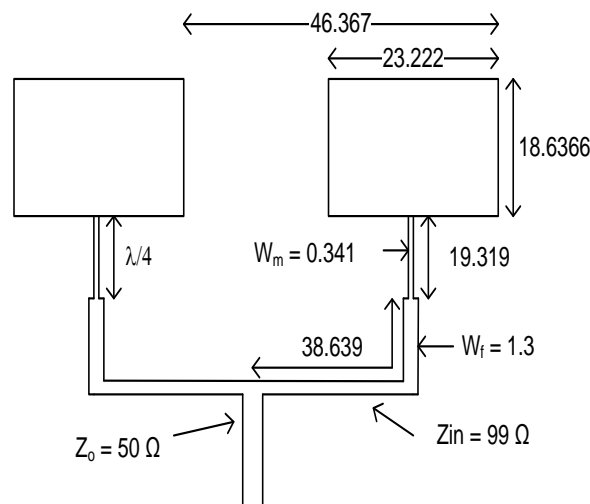

**Figure 4** A two-element patch antenna (dimension in mm).

At fundamental frequency of 2.441 GHz, input impedance is obtained to be

$$Z_{in} = -13,613 - j 55,84; \quad (2)$$

while at the second harmonic frequency, it is found that  $Z_{in} = 99$  ohm, which is dominant resistive at the second harmonic frequency and dominant capacitive at the fundamental frequency.

## 2.2 Design of the Second-Harmonic Antenna

The active second harmonic antenna is obtained when the oscillator circuit is match-combined with the patch array antenna. To match the impedance between antenna elements, a coupling scheme in the form of a transmission line with characteristic impedance of 50 Ohm is used. This is chosen because the input impedance of each antenna element is 99 Ohm, so that using parallel feeding scheme from the active circuit the matching condition can be achieved.

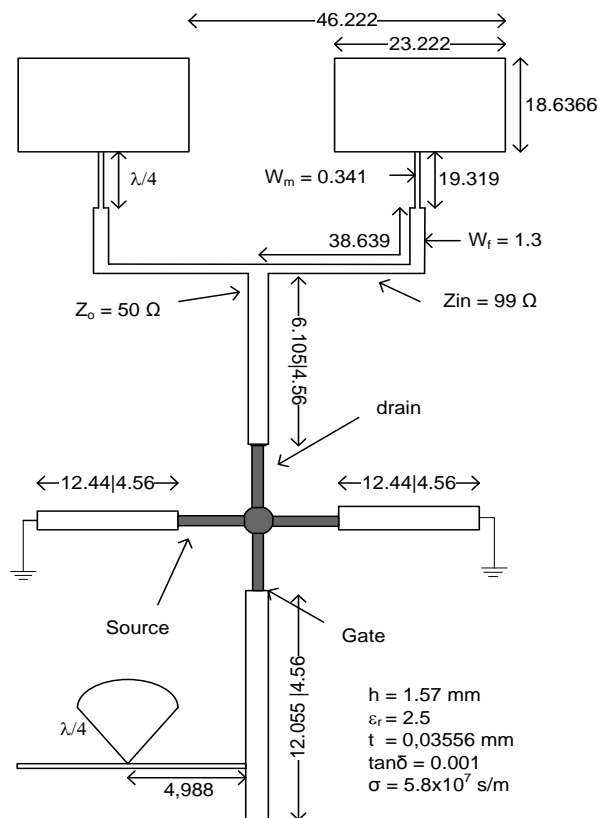

**Figure 5** Active second harmonic antenna (dimension in mm).

Figure 5 shows the top view of the active second harmonic antenna with two elements. Antenna elemen-1 and elemen-2 are the passive component at the two-element patch antenna, which acts as the radiator subsystem. The active component that constitutes the oscillator FET transistor acts as the second harmonic frequency generator.

### 2.3 Simulation Results

The simulation results of the maximum radiation show that at the direction of  $\Phi = 0^\circ$ , the output radiation at the second harmonic frequency is  $P_{2fo2s} = -42$  dBm, while at fundamental frequency is  $P_{fo2s} = -87$  dBm (see Table 1).

**Table 1** Output power of single patch antenna.

$P_{dc} = V_{gs} I_{gs} + V_{ds} I_{ds}$ (DC input power) $P_{dc} = 60 \text{ mW} =$ $-17.78 \text{ dBm}$	$(V_{gs} = 0, I_{gs} = 0, V_{ds} = 3., I_{ds} = 20 \text{ mA})$	
Output power without harmonic generation $P_{out\_an1s} = P_{fo1} + P_{2fo1}$ $= -22.3 \text{ dBm}$	Output power of fundamental frequency $P_{fo1s} = -22.3 \text{ dBm}$	Output power of second harmonic frequency $P_{2fo1s} = -48.8 \text{ dBm}$
Output power of second harmonic frequency design $P_{out\_an2s} = P_{fo2} + P_{2fo2}$ $P_{out\_an2s} = -42 \text{ dBm}$	Output power of fundamental frequency component $P_{fo2s} = -87 \text{ dBm}$	Output power of the second harmonic frequency component $P_{2fo2s} = -42 \text{ dBm}$

This shows that the design and simulation of the second harmonic antenna can generate the second harmonic frequency output power that is much higher than its fundamental frequency. In other words, the design is achieved to suppress the fundamental frequency and other harmonic frequencies except the second harmonic frequency. To see the loss due to the second harmonic design, we found that the total output power at the second harmonic frequency is  $P_{2fo2s} = -42$  dBm; while the total output power of fundamental frequency without the second harmonic design is  $P_{out\_an1s} = -22.3$  dBm showing a loss factor of 19.7 dB resulted from the second harmonic frequency generation. The loss factor is the price to pay for the second harmonic frequency design. The additional loss of the output power due to construction of the second harmonic frequency design is found to be 6.8 dB, so that the effective output power which can be generated at the second harmonic frequency is  $P_{2fo1s} = -48.8$  dBm.

To see the antenna radiation pattern, Figures 6 and 7 show the electric field pattern for both the fundamental and the second harmonic frequencies of the single patch antenna; while Figure 8 shows the electric field pattern of the two-

element antenna array under consideration at the second harmonic frequency. We can see that the two-element patch antenna shows a slightly different radiation pattern from the single patch antenna due to the pattern superposition of each element.

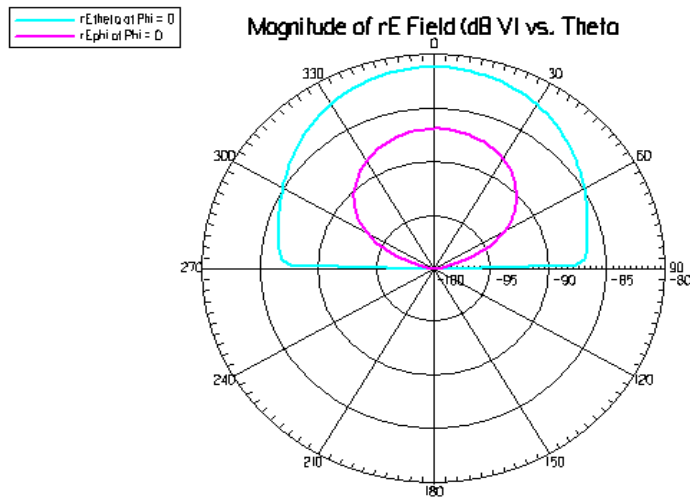

**Figure 6**  $E$  field pattern of the single patch antenna at fundamental frequency.

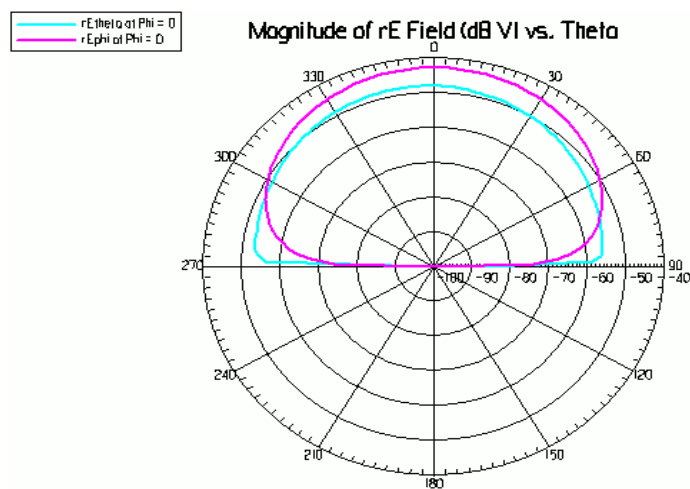
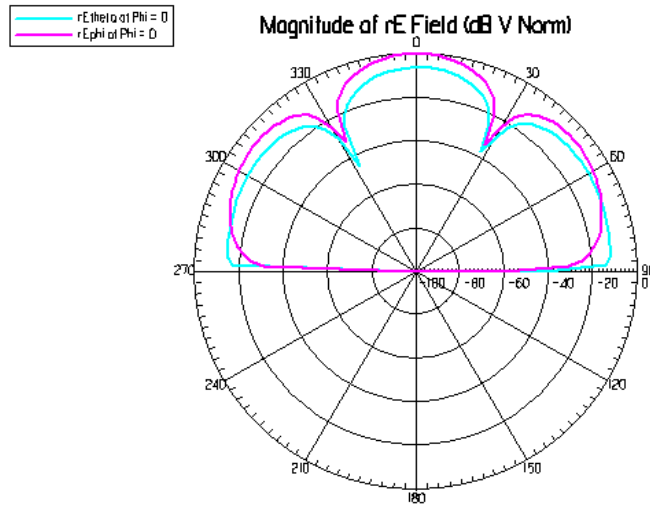

**Figure 7**  $E$  field pattern of the single patch antenna at the 2<sup>nd</sup> harmonic frequency.

Since in this work the patch antenna consists of two element array, the gain increases theoretically by 3 dB. However, the simulation result shows that the



gain measurement of the two-element patch antenna can generate the maximum output power at  $\Phi = 0$  of  $P_{2fo2s} = -40$  dBm, showing only a 2 dB array gain.

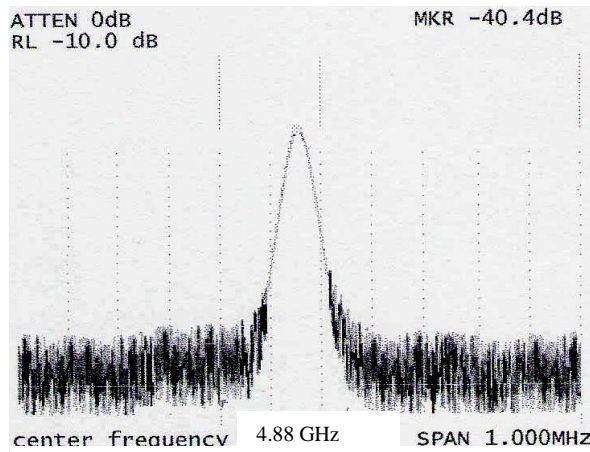

**Figure 8** Radiation pattern of a two-element patch array at the 2<sup>nd</sup> harmonic frequency.

### 3 Antenna Measurement

#### 3.1 Output power measurement

At the direction of  $\Phi = 0^\circ$  for the second harmonic frequency of 4.88 GHz, the output power measurement  $P_U = -47.7$  dBm as shown in Figure 9.



**Figure 9** Measurement of output power at second harmonic frequency (4.88 GHz).

However from simulation, the radiation at the direction of  $\Phi = 0^\circ$  can generate the output power of  $P_{2f_{o2s}} = -42$  dBm. Since the total gain at frequency of 4.88 GHz,  $G_A = 8.2$  dB, and the loss due to the attenuation of transmission line and connector is  $L_{KC} = 5$  dB, the effective level of output power at the second harmonic frequency is then

$$P_{2f_{o2u}} = P_U - G_A + L_{KC} = -47.7 - 8.2 + 5 = -50.9 \text{ dBm} \quad (3)$$

The difference of 8.9 dB between the simulation and the measurement results is due to the accuracy and the shift of the  $S$  parameter resulted in fabrication of the microstrip material. Fabrication of microstrip is performed using etching and chemical processes. The dimension obtained from fabrication is not perfect due to the limited accuracy that can be achieved within available facilities in the laboratory.

To show the output power at the suppressed fundamental frequency, Figure 10 shows the output of the spectrum measurement of the fundamental frequency of 2.44 GHz.

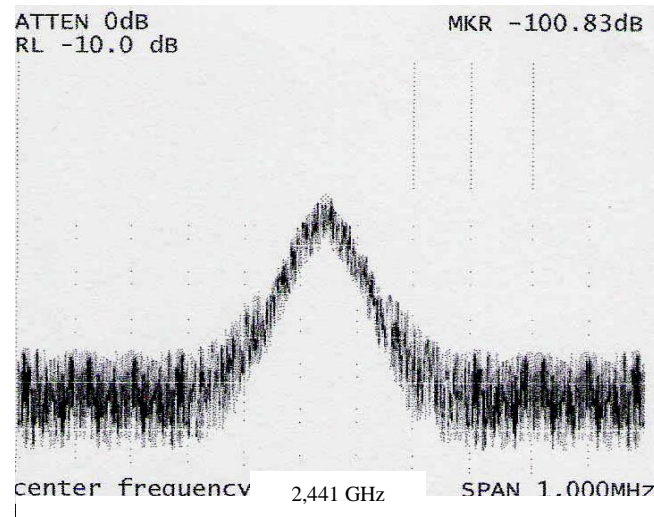

**Figure 10** Measurement of output power at fundamental frequency (2.44 GHz).

At the direction of  $\Phi = 0^\circ$  for the fundamental frequency of 2.44 GHz, the output power measurement  $P_U = -100.01$  dBm. Therefore from the measurement after considering the antenna gain at 2,44 GHz,  $G_A = 5,3$  dB, the output power level obtained from the measurement is

$$P_{f_{o2u}} = P_U - G_A + L_{KC} = -100.01 - 5.3 + 5 = -110.31 \text{ dBm} \quad (4)$$

Simulation result shows that the output power at fundamental frequency is  $P_{fo1s} = -87$  dBm. Similar with the second harmonic frequency generation, the output power of fundamental frequency obtained from measurement is found to be approximately 23.31 dB below its level obtained from simulation.

From both fundamental and second harmonic frequency measurements, it can be inferred that the second harmonic frequency can be optimized and the fundamental frequency component can be suppressed up to approximately 59.41 dB below the second harmonic power level.

The total output power of the active harmonic antenna is  $-50.9$  dBm +  $(-110.31)$  dBm =  $-50.89$  dBm. Therefore, the loss factor due to second harmonic frequency generation is  $-22.29$  dB +  $50.89$  dB =  $28.6$  dB. Therefore, the design of second harmonic frequency is obtained by allowing the total loss of the output power (power loss factor) of  $28.6$  dB.

Table 2 shows the output power of the two-element patch antenna array with and without second frequency generation.

**Table 2** Output power of the two-element patch antenna.

$P_{dc} = V_{gs} I_{gs} + V_{ds} I_{ds}$ (DC supply) $P_{dc} = 60$ mW = $-17.78$ dBm	$(V_{gs}=0, I_{gs}=0, V_{ds}=3., I_{ds}=20$ mA)	
Simulated output power without harmonic frequency $P_{out\_an1} = P_{fo1} + P_{2fo1}$ $P_{out\_an1} = -22.28$ dBm	Simulated output power of fundamental frequency $P_{fo1} = -22.29$ dBm	Simulated output power at second harmonic frequency $P_{2fo1} = -48.77$ dBm
Simulated output power with harmonic frequency $P_{out\_an2s} = P_{fo2s} + P_{2fo2s}$ $P_{out\_an2s} = -42$ dBm	Simulated fundamental frequency $P_{fo2s} = -87$ dBm	Simulated second harmonic frequency $P_{2fo2s} = -42$ dBm
Measured output power with harmonic frequency $P_{out\_an2u} = P_{fo2u} + P_{2fo2u}$ $P_{out\_an2u} = -50.89$ dBm	Measured fundamental frequency $P_{fo2u} = -110.31$ dBm	Measured second harmonic frequency $P_{2fo2u} = -50.9$ dBm

### 3.2 Measurement of Radiation Pattern

Measurement of the antenna radiation pattern for the two-element active antenna at second harmonic frequency is shown in Figure 11. The result shows that the radiation pattern is very similar to that obtained from simulation.

However, some side lobes and also back lobe can be observed in both elevation (theta) and azimuth (phi) patterns. This irregularity of radiation pattern might be caused by accuracy of fabrication and also by imperfectness of ground plane of the microstrip material that constitutes the patch antenna array. As we can observe that on the simulation a perfect conducting plane is assumed to be perfect. Also the thickness reduction of dielectric and conducting plane of the microstrip material during etching process is not taken into consideration in the simulation. This might cause the difference in the characteristic of patch antenna as the radiator. Also ground plane area is in fact not perfect. Imperfect ground plane might cause some parasitic effects to the radiation characteristics of the patch antenna.

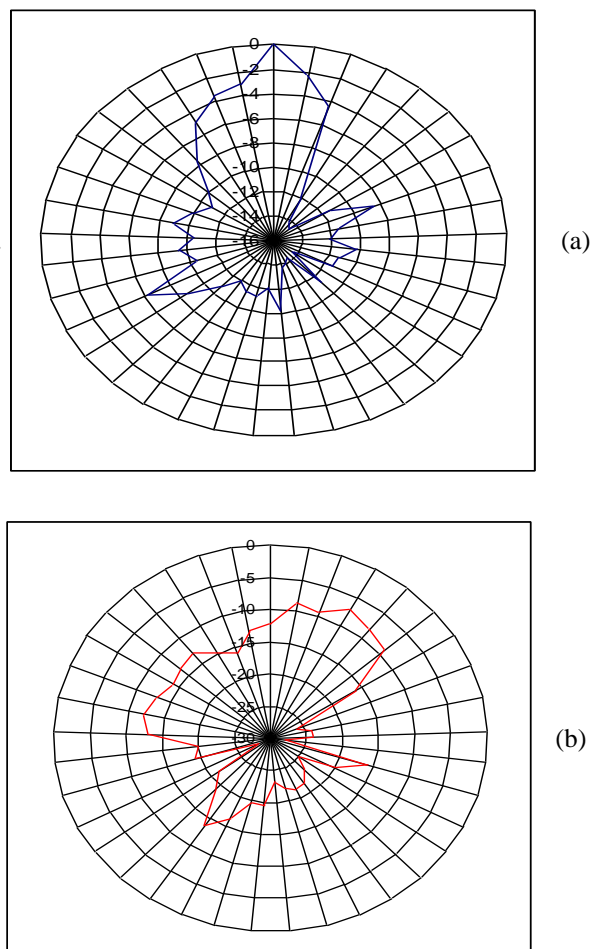

**Figure 11** Radiation pattern of active antenna at second harmonic frequency (a)  $\Phi$  plane (b)  $\theta$  plane.

### 3.3 VSWR and Bandwidth Measurement

The result of VSWR and Bandwidth measurement of the active second harmonic antenna is shown in Figure 12 below.

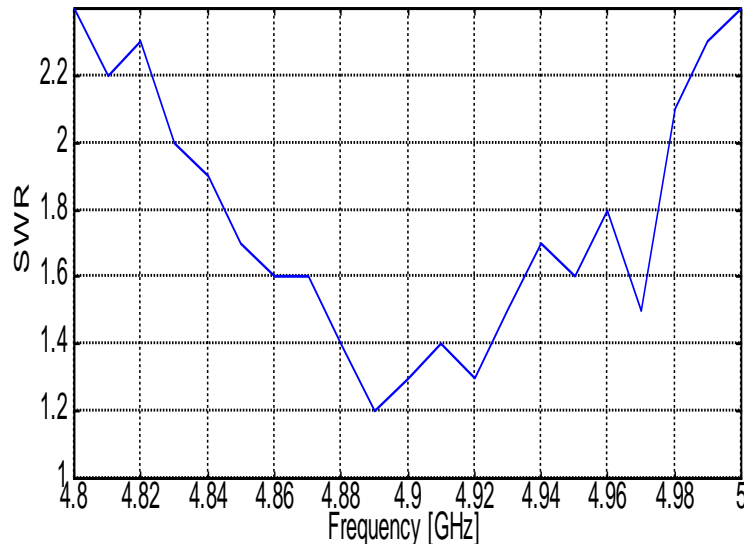

**Figure 12** VSWR and bandwidth measurement of active second harmonic antenna.

From Figure 12, the value of VSWR = 1.5 at the second harmonic frequency can produce a bandwidth of approximately 75 MHz; while with a rather loose requirement of VSWR = 2 the bandwidth obtained can achieve almost 150 MHz. The requirement of VSWR on wireless LAN application, especially for ISM band application, is specified to be between 1.5 and 2. Therefore the second harmonic antenna designed and implemented in this work satisfies the requirement of WLAN application.

## 4 Conclusion

Wireless application of the *ISM* band at 2,4 GHz can be extended using harmonic antenna design, so that the system can be operated at its harmonic frequencies. The second harmonic frequency design has been investigated using active antenna and make it possible to be implemented to operate at 4.8 GHz. Harmonic frequency generation at antenna subsystem is beneficial, in that a higher operating frequency of wireless communication systems can be deployed using lower frequency devices. The system can be realized using active antenna

to generate harmonic frequency. The harmonic antenna system is more efficient compared to conventional frequency multipliers or up converters, because the harmonic antenna can translate the operating frequency into a higher frequency band without requiring frequency multiplier and filters. The antenna subsystem and impedance matching circuit play an important role in the success of harmonic antenna design. The system is designed to have pure resistive impedance at the specified harmonic frequency in order to maximize the output power at that frequency and to suppress other frequency components.

In this work, the second harmonic frequency component is designed to operate at 4.88 GHz. The output power of the second harmonic frequency can achieve  $-50.9$  dBm; while the output power of its fundamental frequency is  $-110.31$  dBm, showing a suppression factor of 59.41 dB. However, to obtain a harmonic frequency radiation, there is an associated loss factor compared to the generation of the fundamental frequency without second harmonic frequency design. In this work, the loss factor of the second harmonic antenna design is approximately 28.6 dB compared to the output power with direct frequency generation (without harmonic design).

Accuracy of the design using microstrip material is affected by the fabrication method and also by ground plane dimension. Impedance matching technique also affects the accuracy of the design. Accuracy on antenna fabrication results in some differences of achievable output power obtained from simulation and that obtained from the real measurement.

## 5 Further Work

To further extend its application, the third harmonic antenna design can be an alternative further research direction. In addition, to exploit the availability of unlicensed band for WLAN applications, the use of 5.2 – 5.8 GHz frequency band of *Unlicensed for National Information Infrastructure* (UNII) together with the ISM at 2.4 GHz band can be investigated using a dual band antenna design. Therefore, a dual band antenna design at those frequency bands can be another interesting further research direction.

## Reference

- [1] Pramudita, A. & Wahyu, Y., *Antena Aktif pada Harmonik Kedua*, in Proceedings of the 6<sup>th</sup> SITIA Conference, Surabaya, May 2005.
- [2] Alexanian, A., Chang, H.C. & York, R. A., *Enhanced scanning range in coupled oscillation arrays utilizing frequency multipliers*, in Proceedings IEEE APS Symp. Dig., Newport Beach, CA, July. 1995, pp.1308-1310.

- [3] Liao, P. & York, R. A., *A New Phase-Shifterless Beam-Scanning Technique Using Arrays of Coupled Oscillators*, IEEE Trans. Microwave Theory Tech., No. 41, October. 1993, pp.1810-1815.
- [4] Wong, *Compact and Broadband Microstrip Antennas*, Willey Inter Science, 2002.
- [5] J.Lin & Itoh, T., *Active Integrated Antennas*, IEEE Trans. Microwave Theory Tech., No. 42, Dec. 1994, pp. 2186-2194.
- [6] Mortazawi, A., Foltz, H. D. & Itoh, T., *A Periodic Second Harmonic Spatial Power Combining Oscillator*, IEEE Trans. Microwave Theory Tech., No. 40, May 1992, pp. 851-854.