

Design and construction of a motorized ginger juice expression machine

Onu Olughu Onu^{1*}, Kayode Joshua Simonyan²

(Department of Agricultural and Bioresources Engineering, Michael Okpara University of Agriculture, Umudike, P.M.B 7267, Umuahia Abia State, Nigeria)

Abstract: A motorized ginger juice expression machine (GJEM) was designed and developed using locally available materials. The developed machine was tested for juice yield, juice expression efficiency, juice expression loss and juice throughput capacity. Fresh ginger rhizomes at 78.69% moisture content were used for the test. The results revealed a juice yield, expression efficiency, expression loss and throughput capacity were 53.77%, 78.78%, 25.5%, and 7.5 kg hr⁻¹ respectively. The GJEM was powered by a 3 Hp single-phase electric motor and is affordable. Drying of ginger rhizome deteriorated the oleoresin content and hence, the value and quality of ginger. The motorized ginger juice expression machine offered an affordable and simple method of processing fresh ginger without drying.

Keywords: expression, pulverize, ginger juice, expression efficiency, expression loss, juice yield

Citation: Onu, O. O., and K. J. Simonyan. 2017. Design and construction of a motorized ginger juice expression machine. *Agricultural Engineering International: CIGR Journal*, 19(3): 163–169.

1 Introduction

Ginger (*Zingiber officinale Roscoe*) is an herbaceous perennial crop, grown as an annual crop for its spicy underground rhizomes. Ginger contains volatile oil, fixed oil, pungent compounds, resins, starch, protein, and minerals (Ravindran and Nirmal, 2005). The characteristic organoleptic properties are contributed by the volatile oil and nonvolatile solvent-extractable pungent compounds. Percentage composition of volatile oil and nonvolatile extract of ginger from Nigeria was given as 2.5% and 6.5% respectively (Akhila and Tewari, 1984; Ravindran and Nirmal, 2005) which accounts for the high demand for Nigerian ginger in international market. Ginger is valued for its essential oils, mainly oleoresin and gingerol, used in pharmaceutical, bakery and soft drink beverage industries as well as culinary and cosmetic preparation. Primary processing of freshly

harvested ginger entails sorting, washing, soaking, splitting or peeling and drying it to a moisture content of 7%-12% (Ebewele and Jimoh, 1981; Onu et al., 2014). Currently, ginger is processed for three principal products: ginger powder, ginger oleoresin, and ginger oil. Processing of these ginger products also involves unit operations such as pulverization, extraction and expression. The bulk of Nigerian ginger is marketed internationally in split-dried form, where the importing countries further process it into industrial products mainly ginger powder, essential oils, oleoresin and ginger ale concentrates. The amount of foreign exchange earned by exporting dry ginger is however very insignificant when compared with the amount spent on importing processed ginger products thereby substantiating the need for industrial processing of the Nigerian ginger within Nigeria (Yiljep et al., 2005).

Ginger juice can be processed either by solvent extraction or mechanical expression method. The chemical extraction method requires the use of organic solvents to recover the oil from the products (Ibrahim and Onwualu, 2005). This method of processing ginger is not generally adopted by farmers due to the high cost and

Received date: 2016-10-29 Accepted date: 2017-01-06

* Corresponding author: Onu, O. O., Department of Agricultural and Bioresources Engineering, Michael Okpara University of Agriculture, Umudike, P. M. B 7267, Umuahia Abia State, Nigeria. Email: tripleonu@gmail.com.

complexity of the equipment used in the extraction. The ginger extract obtained from this process usually has some elements of impurity resulting from dissolved chemicals used in the extraction. The wet extraction process otherwise known as hot water or steam extraction used traditionally by women in rural communities for processing varieties of oil-bearing biological materials (Olaniyan, 2010), falling short of standard especially in quality.

Ginger juice obtained from mechanical expression of pulverized ginger rhizomes offers a value added ginger product which will increase market opportunity for farmers. Pulverization and expression as unit operations can be done using traditional or modern methods, though the former is quite primitive, favours low capacity output and susceptible to increase in microbial load on the crushed ginger (Aderemi et al., 2009). The effect of particle size, moisture content, heating temperature, heating time, applied pressure, and duration of pressing on the yield and quality of mechanically expressed oil from different crops have been investigated by researchers (Adeeko and Ajibola, 1989; Fasina and Ajibola, 1989; Tunde-Akintunde et al., 2001; Olaniyan, 2010). Results showed that these factors had significant influence on the oil yield.

Research work on processing of ginger has been centered on ginger splitting/slicing machines (Simoyan et al., 2014a and 2014b; Guwo, 2008; Simonyan et al., 2003; Chatthong et al., 2001), ginger pulverizing machine (Aderemi et al., 2009), ginger oil extraction (Kamaliroostaa et al., 2013; Ibrahim, 2006), and ginger dryer (Wu et al., 2013). But development of motorized ginger juices expression machine has received minimum attention. Thus, the objective of this study was used to design, develop and test a motorized ginger juice expression machine that will offer a cheap and simple method of processing freshly harvested ginger.

2 Materials and Methods

2.1 Design Considerations

In order to develop an efficient ginger juice expressing machine, the following factors were considered:

i. For durability and prevention of oxidation and corrosion, stainless steel sheet was used for the construction except for the frame, because it does not react with juice from the ginger rhizomes which contain oleoresin and volatile oil.

ii. To ensure flow of ginger rhizomes in the hopper, the hopper design was based on the recommended average angle of repose (34.6°) and the coefficient of friction on stainless steel of fresh whole ginger rhizome (0.57) (see Table 3.1).

iii. Static and dynamic stresses resulting from direct loading, bending and torsion were considered in shaft design.

iv. Quality, availability and cost of construction materials were considered.

v. Variable pitch and tapered screw shaft (auger) was used to ensure maximum conveyance and pressing of the pulverized ginger rhizomes.

2.2 Design Calculations

2.2.1 Pulverizing shaft speed

The pulverizing shaft speed was determined using Equation (1) given by Khurmi and Gupta (2008) as:

$$N_1 D_1 = N_2 D_2 \quad (1)$$

where, N_1 = speed of driving motor, rev min^{-1} ; N_2 = speed of the pulverizing shaft, rev min^{-1} ; D_1 = diameter of driving pulley, m; D_2 = diameter of the driven pulley.

2.2.2 Pressure on the Barrel

The limiting (maximum) pressure (P_b) the barrel can withstand is estimated using the Equations (2) and (3) by Khurmi and Gupta (2008) as:

$$P_b = \frac{t \delta_a}{D_i} \quad (2)$$

$$\delta_a = 0.27 \delta_o \quad (3)$$

where, δ_a = allowable stress, MPa; δ_o = yield stress of barrel material, MPa; t = barrel thickness, mm; D_i = internal diameter of barrel, mm.

Given: $t=2$ mm, $\delta_o=215$ MPa; at feed point, $D_i=80$ mm, and at discharge point, $D_i=65$ mm.

2.3 Design of screw shaft for the expression unit

Design of shafts of ductile material based on strength is controlled by maximum shear theory. The shaft is subjected to combined torsion and bending load. For a solid shaft having little or no axial loading, the ASME

code Equation (4) was given as ASME (1995):

$$d^3 = (16/\pi S_s) \times [(K_b M_b)^2 + (K_t M_t)^2]^{1/2} \quad (4)$$

where, d = diameter of the shaft; mms; M_t = torsional moment; Nm; M_b = maximum bending moment; Nm; K_b = combined shock and fatigue factor applied to bending moment; K_t = combined shock and fatigue factor applied to torsional moment; S_s = Allowable shear Stress, MPa.

For rotating shafts subjected to suddenly apply load with minor shocks only, values for K_t and K_b was given

as 1.5 according to Khurmi and Gupta (2008).

For shafts with allowance for keyways,

$$S_s = 42 \times 10^6 \text{ Nm}^{-2} \quad (5)$$

Beam analysis software (Beamboy, Version 2.2) was used to determine the maximum bending moment on the shaft. From Figures 1a and 1b, the value of maximum bending moment is 0.0245 N-m (24.5N-mm).

A stainless steel rod of diameter 30 mm was selected, giving considerations for bearings.

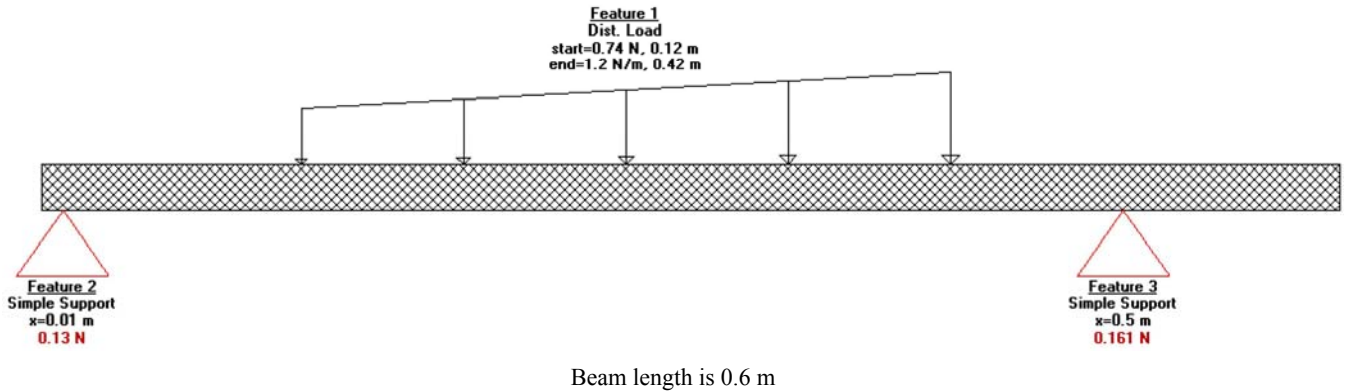

Figure 1a Free body diagram of the screw shaft showing loads and reactions

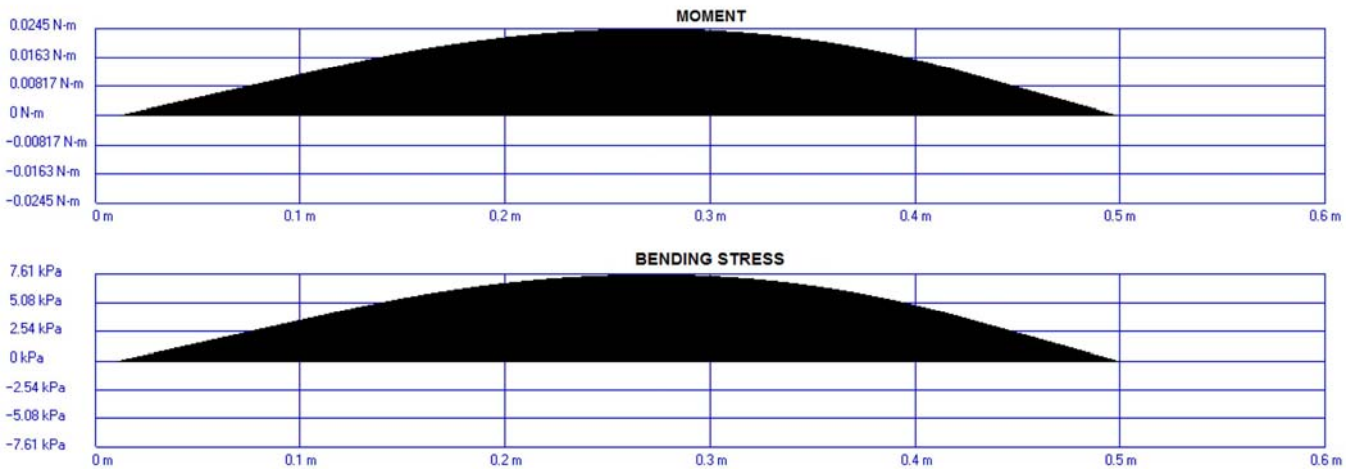

Figure 1b Bending moment and stress diagrams of the screw shaft

2.4 Screw pitch (P_s)

The pitch of the screw of the screw shaft was determined by Equation (6) given by Shigely and Mitchell (1983) as:

$$P_s = \pi \tan \phi d_{sm} \quad (6)$$

where, ϕ = lead angle, °; d_{sm} = mean diameter of shaft, mm.

The screw has a variable pitch with maximum and minimum lead angle as 26° and 10° respectively.

2.5 Screw thread design

The screw shaft is essentially a tapered screw conveyor with the volumetric displacement decreasing from the feed end of the barrel to the discharge end. In

this way, the pulverized ginger is subjected to pressure which expels juice from as it is propelled forward during the screwing process. The screw threading system was designed as a step up shaft diameter and decreasing screw depth using the expression in Equation (7):

$$U_n = a + (n - 1)d \quad (7)$$

where, U_n = screw depth at the discharge end, mm; a = screw depth at feed end, mm; n = no of screw turns; d = common difference between next successive screw depths.

Given that $U_n = 16$ mm, $a = 24$ mm, $n = 8$; then $d \approx 2$ mm.

2.6 Design for capacity of the machine

The expressing capacity of the developed machine was determined using a modified form of the Equation (8) given by Onwualu et al. (2006) as:

$$Q_e = 60 \times \frac{\pi}{4} (D_{ms}^2 - d_s^2) P_{ms} \rho N_s \Phi \quad (8)$$

where, Q_e = theoretical capacity of the expressing unit, kg s⁻¹; D_{ms} = mean screw diameter; d_s = shaft diameter; ρ = crop density, kg m⁻³; P_{ms} = mean screw pitch, mm; N_s = shaft speed, rev min⁻¹; Φ = filling factor.

The pulverizing capacity of the machine was determined using a modified form of Equation (9) given by Onwualu et al. (2006) as:

$$Q_p = 60 \times \frac{\pi}{4} (D_s^2 - d_p^2) P_s \rho N_p \Phi \quad (9)$$

where, Q_p = theoretical capacity of the pulverizer, kg s⁻¹; D_s = screw diameter, mm; d_p = pulverizing shaft diameter; ρ = crop density, kg m⁻³; P_s = screw pitch, mm; N_p = pulverizing shaft speed, rev min⁻¹; Φ = filling factor.

2.7 Design for the power requirement of the machine

The power required by the machine for expressing juice was determined using Equation (10) adapted from Onwualu et al. (2006) as:

$$P_e = Q_{ve} L_s \rho g F \quad (10)$$

where, P_e = power required for expressing, W; Q_{ve} = volumetric capacity, m³ s⁻¹; L_s = length of screw shaft, mm; g = acceleration due to gravity, m s⁻²; F = material factor.

The power required by the machine for pulverizing was determined using Equation (11) adapted from Onwualu et al. (2006) as:

$$P_p = Q_{vp} L_p \rho g F \quad (11)$$

where, P_p = power required for pulverizing, W; Q_{vp} = volumetric capacity, m³ s⁻¹; L_p = length of pulverizing shaft, mm; g = acceleration due to gravity, m s⁻².

The total power requirement (P_t) of the machine was computed using Equation (12)

$$P_t = P_e + P_p \quad (12)$$

The power of the electric motor required to drive the machine was estimated from Equation (13) given by Onwualu et al. (2006) as:

$$P_m = \frac{P_t}{\eta} \quad (13)$$

where, P_m = power of electric motor; η = drive efficiency.

2.8 Description of the motorized ginger juice expression machine

The developed GJEM consists of the following major components: feeding unit, pulverizing unit, juice expression unit, juice drainage point (outlet), waste outlet, frame and power transmission system.

2.9 Frame

The two design factors considered in determining the material required for the frame are weight and strength. The frame was constructed with 38 mm×38 mm×3 mm mild steel angle iron. The frame provides firm support for the entire assembly. Based on anthropometric considerations, the overall dimensions of the frame was chosen as 610 mm×390 mm×790 mm.

2.10 Feeding unit

The hopper is a stationary part and mounted onto the machine forms the feeding chute through which sliced ginger rhizomes are fed into the pulverizing unit by gravity. Feeding does not need any energy; is sufficient for feeding. The passage hole (85 mm×55 mm) of the hopper was large enough in order to prevent choking of the product. The hopper was made of stainless steel and was rectangular pyramid in shape.

2.11 Pulverizing unit

The pulverizing unit consisted of a shaft with a screw conveyor and two attrition plates attached to one end. One of the attrition plates was fixed on a stationary horizontally-placed small cylindrical drum, while the other was adjustable to allow the passage of the various sizes of the sliced ginger rhizomes. As the shaft rotates in the drum, it pulverized the whole ginger rhizomes into smaller sizes and they were conveyed by gravity to the position where it entered the expression unit through the lower hopper. The pulverizer was made of stainless steel to avoid any reaction with the juice.

2.12 Ginger juice expression unit

The ginger juice expression unit consisted of a tapered cylindrical barrel which covers a perforated tapered cylindrical drum that housed a screw shaft. The screw shaft was the main component of the juice expression unit. The screw shaft was a stainless shaft with a tapered helical screw of variable pitch. The pitch of the

screw flights gradually decreased towards the discharge end, to increase the pressure on the pulverized ginger rhizome as it is carried through the barrel. The barrel was perforated to allow expressed juice to escape. The diameter of the perforation was in 1mm. The pressed ginger residue (chaff) passes through the waste discharge point in the barrel outlet.

2.13 Power transmission system

The power transmission system comprises the prime mover (electric motor), shaft, reduction gear, pulleys and belt. The power was provided by a 2 HP, 1400 rpm and 1 HP, 1430 rpm prime movers. The V-belts and pulley assembly were used to transmit the power to the pulverizing and expression units at a speed of 646 rpm and 240 rpm respectively. The prime movers were mounted on a slotted plate on the frame to facilitate adjustment of the belt tension.

2.14 Working principle of the developed GJEM

The GJEM performs two distinct unit operations- size reduction and separation processes. The ginger rhizomes are fed into the pulverizer through the hopper. The ginger rhizomes are comminuted by shearing and rubbing at the pulverizing unit. The screw shaft of the expression unit crushes, presses and conveys the product that comes from the pulverizing unit in such a way that juice is squeezed out of the pulverized rhizomes. The expression is actually achieved by the action of the screw shaft in squeezing the pulverized ginger rhizomes against each other and on the surface of the screw and the perforated cylindrical barrel along the line of travel. The juice expressed is drained through the juice channel into the juice outlet from where it is collected while the residual waste is collected at the waste outlet.

2.15 Experimental procedures

Fresh ginger rhizomes were obtained from a local market in Umuahia to test the developed ginger juice expression machine. The moisture content of the ginger rhizomes used during the test was 78.69%. The ginger rhizomes were washed, sliced and prepared ready for juice expression. The machine was set into operation and known weights of sliced ginger rhizomes were fed into the pulverizer where they were pulverized and transferred into the expressing unit. The feeding time and expressing

shaft speed were recorded.

The juice expressed and residual waste were collected and weighed separately. The values obtained were used to calculate the juice yield, extraction efficiency and extraction loss. Each of the tests was done in two replications.

2.16 Performance indicators

The performance of the machine was evaluated based on the following performance indicators:

- i. Extraction efficiency (J_E)
- ii. Juice yield (J_y)
- iii. Extraction loss (E_L)
- iv. Throughput capacity (C_T)

C_T was calculated from Equation (14), while J_E , J_y and E_L were calculated using Equations (15), (16) and (17) given by Olaniyan and Oje (2011).

$$C_T = \frac{Q_o}{t} \quad (14)$$

$$J_E = \frac{100W_{JE}}{xW_{fs}} \% \quad (15)$$

$$J_y = \frac{100W_{JE}}{W_{JE} + W_{RW}} \% \quad (16)$$

$$E_L = \frac{100[W_{fs} - (W_{JE} + W_{RW})]}{W_{FS}} \% \quad (17)$$

where, Q_o =total quantity of ginger juice collected at the outlet, g; t =time taken to complete expression, sec.; W_{JE} =weight of juice expressed, g; W_{RW} =weight of residual waste, g; W_{fs} =weight of feed sample, g; W ; x =juice content of ginger in decimal.

3 Results and Discussions

The design calculated parameters used for the machine fabrication are presented in Table 1, while Figures 2 and 3 showed the isometric and exploded views of the developed machine respectively.

The mean juice yield, expression efficiency, expression loss, and throughput capacity were 53.77%, 78.78%, 25.5% and 7.5 kg hr⁻¹ respectively, at a moisture content of 78.69%. The method used in this study for calculating juice yield, extraction efficiency and extraction loss had been used earlier by Olaoye and Oyelade (2012) and Olaniyan and Obajemihi (2014) for sugar cane juice and mango juice extraction, respectively.

Table 1 Calculated design parameters

S/N	Design Parameters	Value
1.	Pulverizing shaft speed	646 rpm
2.	Pressure on the barrel at feed point	1.45 N m ⁻²
3.	Pressure on the barrel at discharge point	1.79 N m ⁻²
4.	Screw shaft diameter for expression unit	30 mm
5.	Maximum screw pitch	50 mm
6.	Minimum screw pitch	20 mm
7.	Expression unit capacity	376 kg S ⁻¹
8.	Pulverizing unit capacity	448 kg S ⁻¹
9.	Power requirement for expression	1124 W
10.	Power requirement for Pulverizing	660 W
11.	Total power requirement of the machine	1784 W
12.	Power of electric motor	2230 W or 3.0 HP

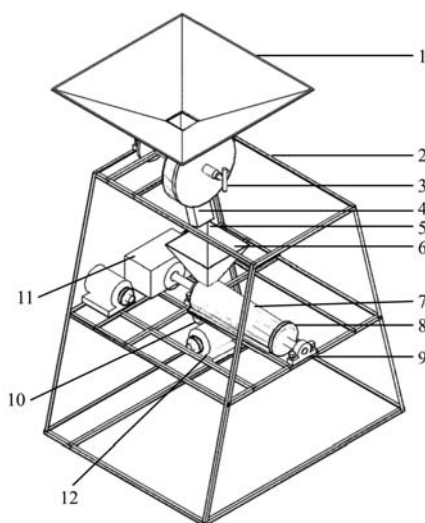

1. Pulverizing hopper 2. Frame 3. Adjustment knob 4. Pulverizing unit
5. Pulverized ginger outlet 6. Expression hopper 7. Expression unit 8. Chaff outlet 9. Bearing 10. Juice outlet 11. Speed reduction gear 12. Electric motor

Figure 2 Isometric View of the Motorized Ginger Juice Expressing Machine

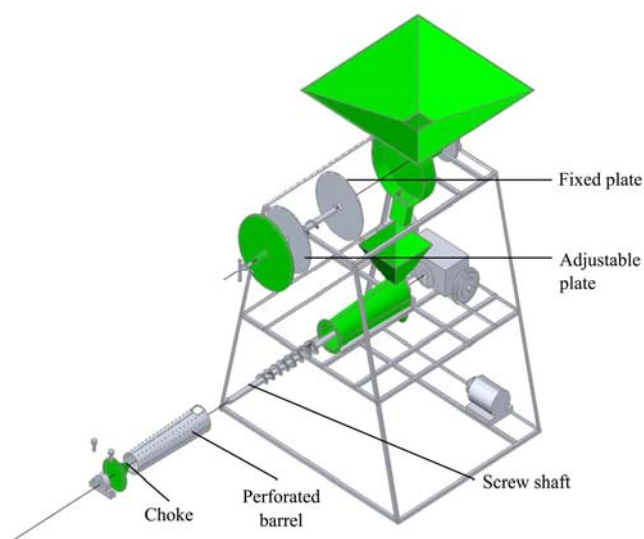

Figure 3 Exploded view of the motorized ginger juice expression machine

The results of the test showed that the machine performed satisfactorily but there is still room for improvement. An improvement in the design of the pulverizing unit is expected to improve the efficiency of pulverization process in terms of feed rate and throughput capacity; hence, this is recommended for further study. Such improvement would involve adopting a grating principle instead of attrition as used in the design of the pulverizing unit.

4 Conclusions

A motorized ginger juice expressing machine was designed, developed and tested. The machine developed has mean juice yield and expression efficiency of 53.77% and 78.78% respectively with a mean throughput capacity of 7.5 kg hr⁻¹. The motorized ginger juice expression machine offers an affordable and simple method of processing fresh ginger; hence, minimizing loss in ginger quality due to drying and extending harvest of ginger rhizomes. It can be used for small scale ginger juice expression in the rural and urban communities. The design of the pulverizing unit should be improved to enhance the efficiency and throughput capacity of the machine.

References

- Adeeko, K. A. and O. O. Ajibola. 1989. Processing factors affecting yield and quality of mechanically expressed groundnut oil. *Journal of Agricultural Engineering Research*, 45(5): 31–43.
- Aderemi, B. O., V. I. O. Ndirika, and Y. Yerima. 2009. Design and fabrication of a medium scale ginger pulverizing machine for rural dwellers. *Australian Journal of Basic and Applied Science*, 3(2): 389–394.
- Akhila, A., and P. Tewari 1984 .Chemistry of ginger: a review. *Current Research on Medicinal and Aromatic Plant*, 6(3): 143–156.
- ASME. 1995. *Design of Transmission Shafting*. New York: ASME.
- Chatthong, J., W. Boonchouytan, and R. Burapa. 2011. Design and construction of the semi-automatic sliced ginger machine. *World Academy of Science, Engineering and Technology Journal*, 5(12): 2675–2680
- Ebewele, R. O., and A. A. Jimoh. 1981. Feasibility study of Kaduna state ginger processing industry. *Ahmadu Bello University Chemical Engineering Consultant*, 1-45, 50-56, 63–80.

- Fasina, O. O., and O. O. Ajibola 1989. Mechanical expression of oil from Conophor nut. *Journal of Agricultural Engineering Research*, 44(89): 275–287.
- Guwo, A. N. 2008. Development of a ginger splitting machine. Ph.D. diss., Department of Agric and Engineering, Ahmad Bello University, Nigeria.
- Ibrahim, K. A. 2006. Extraction of essential oils from ginger rhizome using steam distillation method. Ph.D. diss., Faculty of Chemical and Natural Resources Engineering University College of Engineering and Technology, Malaysia.
- Ibrahim, K. A., and A. P. Onwualu 2005. Technologies for extraction of oil from oil-bearing agricultural products: a review. *Journal of Agricultural Engineering and Technology*, 13(1): 58–70.
- Kamaliroostaa, Z., L. Kamaliroosta, and A. H. Elhamiradc. 2013. Isolation and identification of ginger essential oil. *Journal of Food Biosciences and Technology*, 3(3): 73–80.
- Khurmi, R. S., and J. K. Gupta. 2008. *A Textbook of Machine Design*. New Delhi: S. Chand and Company,
- Loewenthal, S. H. 1978. Design of transmission shafting. *American Society of Mechanical Engineering*, 3(1): 114.
- Olaniyan, A. M. 2010. Effect of extraction conditions on the yield and quality of oil from castor bean. *Journal of Cereals and Oilseeds*, 1(2): 24–33.
- Olaniyan, A. M., and O. I. Obajemihi. 2014. Design, development and test of a small scale mango juice extractor. *Journal of Agricultural Science and Technology*, 4(1B): 1–7.
- Olaoye, J. O., and O. A. Oyelade. 2012. Synthesis and analysis of a slider crank linkages in sugarcane juice extractor. *Global Journal of Pure and Applied Science and Technology*, 2(1): 10–26.
- Onu, O. O., K. J. Simonyan, and M. C. Ndukwu. 2014. A review of post harvest processing technologies of ginger (*zingiber officinale*). In *Proc. 15th International Conference of the Nigerian Institution of Agricultural Engineers*, 203–210. Akure, 22–25 September.
- Onwualu, A. P. C., C. O. Akubuo, and I. E. Ahaneku. 2006. *Fundamentals of Engineering in Agriculture (1st edition)*. Lagos: Immaculate Publications Ltd.
- Ravindran, P. N., and B. K. Nirmal. 2005. *Ginger: The Genus Zingiber*. Florida, USA: Taylor and Francis Ltd Press.
- Shigley, J., and L. Mitchel 1986. *Mechanical Engineering Design, 4th Ed.* USA: McGraw- Hill
- Simonyan, K. J., A. B. Eke, J. C. Adama, J. C. Ehiem, and D. A. Okpara. 2014a. Performance evaluation of motorized ginger rhizomes splitting machine. *Agricultural Mechanization in Asia, Africa and Latin America*. 45(3): 22–27.
- Simonyan, K. J., A. B. Eke, J. C. Adama, J. C. Ehiem, U. N. Onwuka, A. R. Iheke, B. N. Nwankwojike and D. A. Okpara. 2014b. Design and development of a motorized ginger rhizomes splitting machine. *Journal of Applied Agricultural Research*, 6(1): 121–130.
- Simonyan, K. J., K. M. Jegede, and S. W. Lyocks 2003. Development of a motorized ginger slicer. *Agricultural Mechanisation in Asia Africa and Latin America*, 34(1): 37–41.
- Tunde-Akintunde T. Y., B. O. Akintunde, and J. C. Igbeka. 2001. Effects of processing factors on yield and quality of mechanically expressed soybean oil. *Journal of Agricultural Engineering Technology*, 9: 39–45.
- Wu, X., G. Szrednicki, and R. H. Driscoll. 2013. Thin layer drying of ginger. *Acta Horticulturae*, 989(989): 369–375.
- Yiljep, Y., G. Fumen, and E. Ajisehiri. 2005. The effects of peeling, splitting and drying on ginger quality and oil/oleoresin content. *Agricultural Engineering International: CIGR Journal*, 7(2005): 1–8.