

Working planning in packing houses of flowers mixed farms to increase the yield

A. Bechar¹, G. Vitner²

(1. Agricultural Research Organization, Institute of Agriculture Engineering , Bet-Dagan, 50250, Isreal,;

2. Ruppin Academic Center, School of Engineering , Emek-Hefer, 40250, Isreal)

Abstract: The study deals with performance improvement in flowers mixed farms. The farm under investigation is located in the central part of Israel and grows three types of green ornamentals: Pittosporum, Aralia and Aspidistra. The farm consists of 8 hectares and employs 7 workers. The annual yield of the farm in 2009 was 3.5 million branches. The study investigates the working processes of the packing house. A computer model and work planning management tool was developed using MATLAB. The model inputs are: flower type and quantity, due date and sales price. The output is a work schedule. Results show an improvement of processing time by: 47% for Pittosporum, 19% - 45% for Aralia, and 23% - 54% for Aspidistra.

Keywords: flowers, operations management, work methods

Citation: A. Bechar, G. Vitner. 2011. Working planning in packing houses of flowers mixed farms to increase the yield. Agric Eng Int: CIGR Journal, 13(3).

1 Introduction

Flower production in Israel is grown on 5,000 ha and results in an annual export of one Billion flowers with total revenue of about 120 million US Dollars. The annual sales of green ornamentals is presented in Figure 1, where the three types under study (Pittosporum, Aralia, Aspidistra) take up about 50%. There are about 800 farmers competing in the market. Each farmer grows up to 15 flower types where on a daily basis they usually produce 3-4 flower types. In order to survive in the market they should establish an efficient infrastructure for their product to conform to market demands and quality standards. The main marketing channels are: a. the flower markets mainly in Netherland, and b. private dealers.

Scheduling of farm work and the selection and allocation of machinery and labor to finish field operations within a short span for effective crop

production are critical decisions that farmers take on a

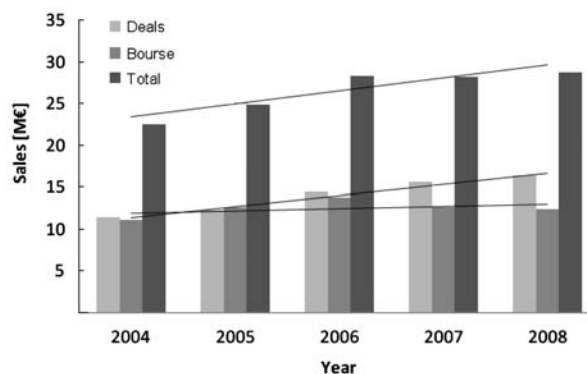

Figure 1 Israel annual green ornamentals sales

daily basis. It is difficult for them to construct an optimal farm work plan. The daily work for employees in the agricultural production corporations is intensive; and they are rather accustomed to working by traditional experiences. Furthermore, many uncertainties in the farming working environment, such as changes in weather, machinery, and labor lead to troubles in work planning by traditional methods (Guan et al., 2008). Their study introduces a hybrid Petri net model for work flow in agriculture production. Van de Werken (1990) presents a labor planning model for vegetables growing.

Received date: 2011-05-30 Accepted date: 2011-11-23

Corresponding author: A. Bechar, Email: avital@volcani.agri.gov.il

The inputs include total area, crop type and area per crop, work force data, storage facilities and machinery data. The model detects bottleneck work stages and specifies a planning period of two weeks. Operations management in bio-production domain is characterized by short operational time windows, wide spatial distribution, traffic ability and workability issues, while sustainability aspects have also been taken into consideration (Bochtis, 2010). Furthermore, additional demands on the precision and integration of scheduling, planning and control functions require that the planning tasks allocated in the machinery team and correspondent labor, needs to consider the interaction of machine, biological, and metrological factors. Bochtis (2010) presents operations research management tools to be utilized in the four main functional areas of the agri-food supply chain: production, harvesting, storage and distribution. Foulds and Wilson (2005) in their study specified the activity of each worker and each actual machine of each type in each time period in order to minimize the duration of the entire harvesting process. They introduced the input data needed for the analysis of a harvesting scheduling: the sequence of operations, the number of machines that are available to perform each operation, the set up time for each type of machine and the number of workers available. They developed an Integer Programming model solved by heuristic techniques. Arjona et al. (2001) developed a simulation model to create weekly plans for allocating labor and machinery for a sugar cane plantation. Simulation results proposed the minimum number of workers to produce a given crop yield. Tadesse and Borowiecki (1991) introduced the 'Project Evaluation and Review technique' (PERT) to plan, monitor and control manual work in coffee fields.

Flow shop scheduling is one of the most important problems in the area of production management. It can be briefly described as follows: there are a set of m machines (work stations) and a set of n jobs (e.g. various flower orders). Each job is comprised of a sequence of operations which are performed on different machines. All jobs have the same processing operation order when passing through the machines. There are no precedence constraints among operations of different jobs and each

machine can process only one operation at a time. The problem is to find the job sequences on the machines which minimize the makespan, i.e. the maximum of the completion times of all the operations. Flow shop manufacturing floors are commonly named as Layouts by Product. Job shop scheduling problem is even a more complicated problem. Like in the flow shop problem there are a set of m machines and a set of n jobs, only in this case do all the jobs not necessarily have the same processing operation order when passing through the machine shop to complete the job. Job shop manufacturing floors are commonly named as Layouts by Process (Seda, 2007).

Flowshops are frequently found in industry and are characterized by a set of jobs, J , where $J = 1; 2; n$ and a set of machines, M , where $M = 1; 2; m$. The set of n jobs is processed sequentially on m machines. In the traditional flowshop problem, we assume deterministic processing times, denoted by p_{ij} , where indices i and j represent a machine and a job, respectively. Furthermore, all jobs are ready for processing at time zero and no other jobs arrive later; a job may not be preempted by another job; jobs are not allowed to pass others; no job may be processed by more than one machine; machines may process no more than one job at a time; and there are no down times due to machine breakdown or maintenance. In a flowshop problem, we usually determine the sequence of jobs to satisfy certain performance criteria including the minimization of the completion time of the last job in the sequence (C_{max}), the sum or the mean of the job flowtime (time in the system for each job), the mean tardiness or lateness, the maximum tardiness, and the number of tardy or late jobs (Easwaran et al., 2010). Most flowshop problems have been proven to be NP-hard (Pinedo, 2008). The seminal work by Johnson (1954), in which a tractable algorithm for the minimization of a two-machine flowshop was presented, is perhaps the most notable exception.

There are multiple situations where machines or workers must execute certain jobs in daily time. During a working day it may be that some workers or machines are not available to perform their activities during some time periods. When scheduling models are used in these

situations, workers or machines are simply called “machines”, and the temporal absences of availability are known as “breakdowns” (Alcaide, et al., 2002). It considers some of these cases studying stochastic scheduling models with several machines to perform activities.

Scheduling in production systems is being carried out with multiple objectives in practice. Production managers would wish to minimize the time taken to process a set of jobs (i.e., makespan) to keep the system’s utilization at a maximum. They also want to achieve fairness to individual jobs by minimizing the variance of job completion times or commit to the customer deadlines by minimizing variability of completion times from due-dates. The objective of minimizing makespan is a regular and common measure of performance. The makespan problem has no polynomial solution even for the two-job two machine case. Hence, researchers have used either implicit enumeration techniques, such as branch-and bound algorithms, dynamic programming to obtain optimal solutions for problems with limited number of jobs, or heuristics to find near optimal solutions for problems with a large number of jobs (Viswanath et al., 2006).

Ruiz-Torres et al. (2011) investigated the benefits of operations flexibility in a flowshop when the goals are to minimize the completion time of all the jobs and the utilization of the workstations. Operations flexibility in a flowshop environment refers to the ability of the shop to organize the production tasks along the production resources. As in a regular flowshop, there is a fixed sequence of operations for the products; however, with this flexibility the “location” of each operation within the flow is not fixed. In the flowshop problem, the production resources are the machines or workstations; thus, operation flexibility relates to the assignment of the production tasks to the workstations, with the assumption that there are more tasks than workstations and that the workstations can be assigned to perform any of the tasks. This type of flexibility is typically available during the organization of production systems that employ people (manual labor) and small tools as the primary components.

Tavakkoli-Moghaddam and Daneshmand-Mehr (2005) developed a computer simulation model for the job shop scheduling problem with the objective function of minimizing the makespan. The model has been coded by Visual SLAM which is a special simulation language. The structure of this language is based on network modeling. Computational results show that the simulation procedure with Visual SLAM is an efficient tool for solving job shop problems by minimizing the makespan, especially for large-scale problems. The user has to rebuild the model based on the number of jobs and machines given in the problem. The result obtained from the simulation output helps managers evaluate the performance of the system by knowing machines utilization and other resources, average waiting time of jobs, and average idle time for each machine.

Huq et al. (2004) described the development of a mixed integer linear programming model for a flow shop with multi-processor workstations. The main objective of the model is to minimize makespan through lot-streaming. A secondary objective is to determine workforce size and schedule. A constant daily workload is assumed.

2 Material and methods

2.1 Farm data

Data were collected in a modern farm in the central part of Israel. The farm grows three types of green ornamentals: *Pittosporum*, *Aralia* and *Aspidistra* (Figure 2). The farm consists of 8 ha where 3 ha are *Pittosporum*, 2.5 ha are *Aralia* and 2.5 ha are *Aspidistra*. The study focused on improving work processes of the packing house operated by 5-7 employees. Management activities are performed by the owner. The total yearly outcome for the three products is about 3.5 million branches.

2.2 Packing house processes

Each product flows through a predefined sequence of processes in the packing house, starting with a bulk of branches arriving from the field until the stage where bundles of 10 branches are stored in buckets inside the refrigerator room ready for shipment. The processes are: washing, sorting, bundling, polishing, wrapping and

storing in refrigerator. Figure 3 presents the materials flow in the packing house for the three types of the products under investigation.



a. Pittosporum



b. Aralia



c. Aspidistra

Figure 2 Green ornamentals under study

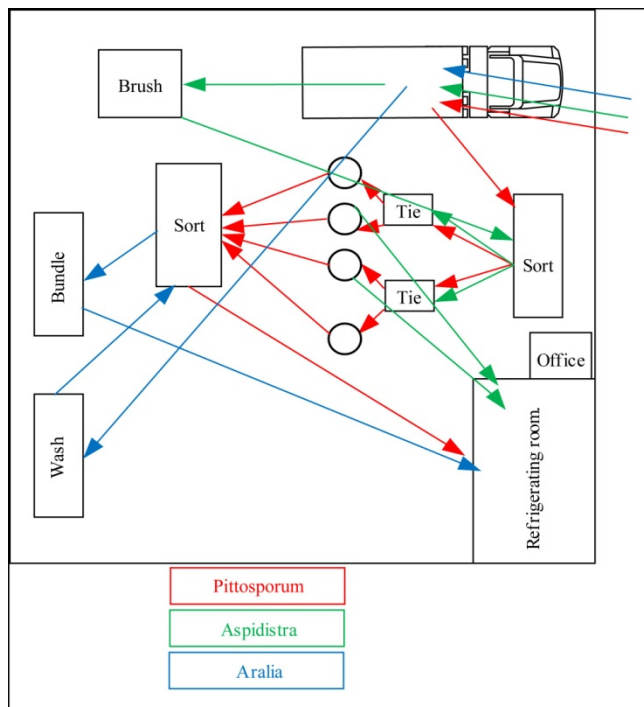

Figure 3 Materials flow in the packing house (the different arrow colors represent the different cultivars)

2.3 Work and time measurement

In this research work studies were performed on the packing house processes of the three cultivars by means of direct measurements and work sampling techniques (Meyers and Stewart, 2001). In the direct measurement method each process was divided into elements and the performance time of each element was measured. To calculate the working time the performance of two to four workers at each working stage for each technique were analyzed. Time measurements were made using work study software developed for handheld computers (Bechar et al., 2005).

2.4 Work planning model

A planning model (in terms of batch size) for managing the shop floor operations in a packing house of flowers mixed farm was developed using Matlab simulating the work processes and working stations in the packinghouse. It assigns customer's order priorities and defines the sequence of flower types to be performed such that it will comply with customer's order characteristics of flower type, quantity of branches and delivery date. The model yields the optimal solution in

regards to: revenue, production costs (hourly wages, materials and equipment), and penalty for tardiness.

The inputs are: product type, quantity of branches, and remaining time to delivery date. The outputs: work policy, number of branches per work station, start/end times for each work station. The constraints: number of employees, delivery date.

The output of the model assigns the starting time and finishing time for a given sequence of orders under investigation, such that it will minimize the Makespan with minimal operating costs. The evaluation of the minimum 'total process time', was conducted using an objective function (Equation (1)). The objective function calculates backward the minimum starting and

finishing times for each station and for the shortest process arrangement of working in series or in parallel taking into consideration constraints as the number of workers, stations sequencing and timing.

$$TPT_J = \sum_{M=1}^m (WIP_{JM} | CT_{JM} + SU_{JM}) \tag{1}$$

where, WIP_{JM} is the number of branches of crop type J in station/machine M . CT_{JM} is the cycle time to process a branch of crop type J in station/machine M and SU_{JM} is the setup time of crop type J in station/machine M .

An example that details the outputs of the model is illustrated in Figure 4. The results enable to allocate the employees to the various work stations to comply with the delivery dates with minimum makespan.

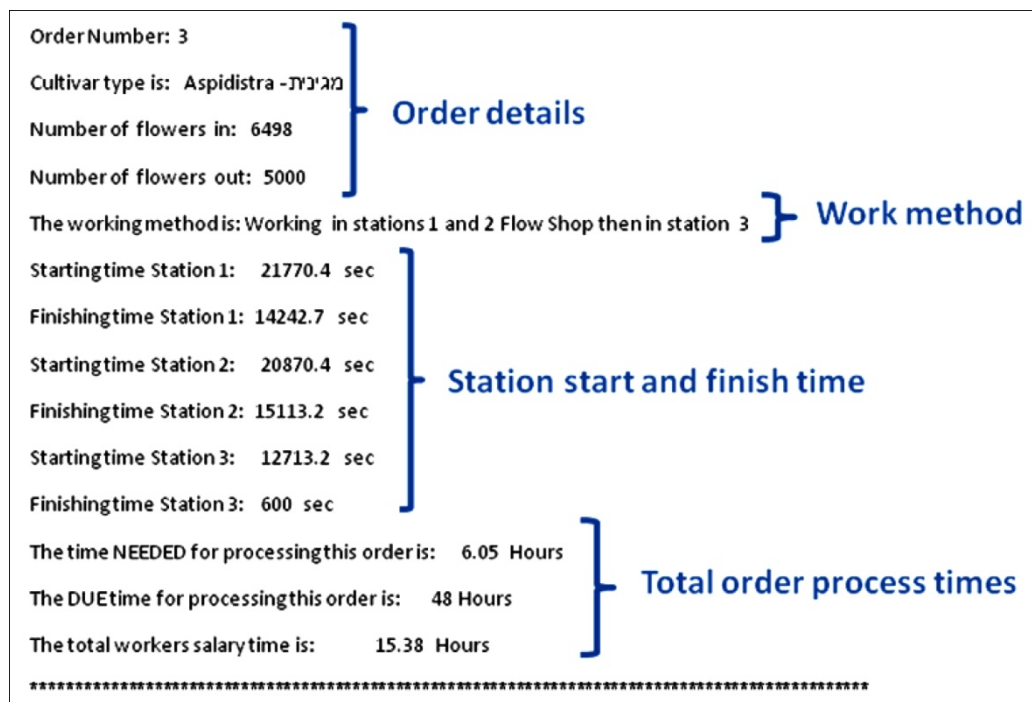

Figure 4 An example of the model's planning results

3 Results

3.1 Time studies

Main findings of the time studies conducted in the different work stages for Pittosporum, Aralia and Aspidistra are presented in Table 1. Table 1 presents the average branch process time in each station of each cultivar investigated. The total time required to manufacture one branch of Pittosporum, Aralia and Aspidistra is 9.74, 13.07 and 10.45 s in average. The station yield in each cultivar is influenced by the process

time and the station manning.

A bottle neck station is the station with the lowest production rate in the process or production line. In the current state examined, the bottle neck stations are the packing station of Pittosporum, the manual sort station of Aralia and the packing station of Aspidistra. The bottle neck stations found in these processes will create starving and blocking effect on the adjacent station after and before the bottleneck station respectively and will make it difficult to operate all station in the process of a specific cultivar simultaneously.

Table 1 Work studies findings for Pittosporum, Aralia and Aspidistra (the numbers in parentheses represent the station manning)

	Aspidistra		Aralia		Pittosporum	
	Processtime/s	Yield/branch · hr ⁻¹	Processtime/s	Yield/branch · hr ⁻¹	Processtime/s	Yield/branch · hr ⁻¹
Machine sort/bundle	-	-	-	-	5.88	2069(2)
Packing	-	-	-	-	3.86	1682(2)
Wash & sort	-	-	3.56	2022(2)	-	-
Manual sort	-	-	4.21	1710(1)	-	-
Auto bundle	-	-	5.3	3396(4)	-	-
Brush	1.02	3529(1)	-	-	-	-
Machine	3.14	3026(2)	-	-	-	-
Packing	6.29	1646(3)	-	-	-	-

3.2 The yield of branches per working day

The influence of the number of workers in the process of each cultivar on the packing house daily yield was examined (Figure 5). In Pittosporum, when the number of workers is five, the daily yield is increased due to the ability to change the work method to flow shop. Increasing the number of workers above five will not influence the total yield. In Aralia, when the number of workers changes from five to six and from eight to nine, the daily yield will be increased due to changes in the task allocation and increase in the work stations efficiency. In Aspidistra, when the number of workers changes from 3 to 4 the task allocation can be changed and the daily yield increases to about 10,000 branches. When the number of workers exceeds 6, the best working process is flow shop and the daily yield increases above 16,000 branches.

Figure 6 illustrates the improvement rate in the process. It shows that there is an improvement relative

to the current state of 47% in process time with 5 or more workers in Pittosporum; 19% with 6-8 workers and 45% with 9 or more workers in Aralia and 23% with 3-4 workers, 27% with 5 workers and 54% with 6 or more workers in Aspidistra.

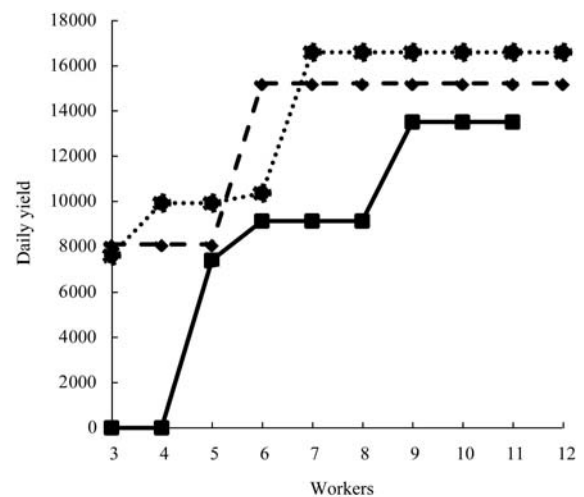

Figure 5 Number of branches as function of number of employees (dashed line, Pittosporum; dotted line, Aspidistra; straight line – Aralia)

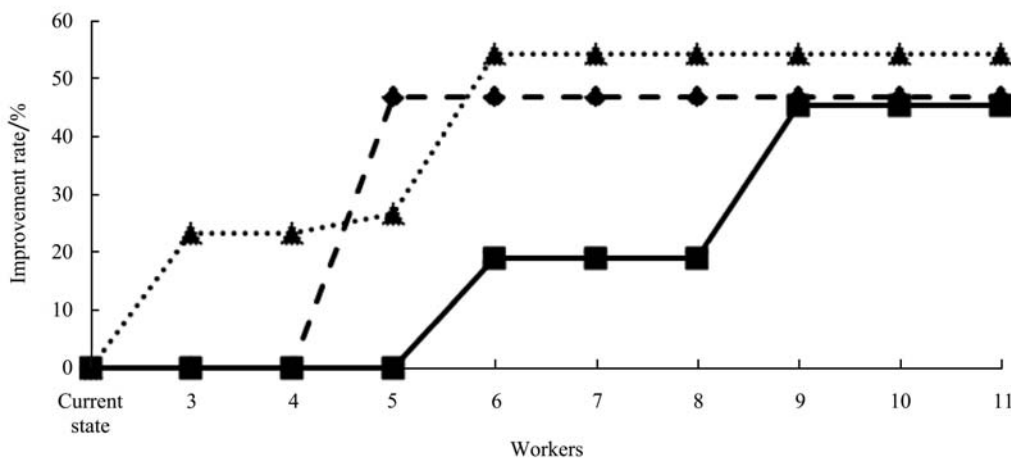

Figure 6 Improvement rate of process time (dashed line, Pittosporum; dotted line, Aspidistra, straight line – Aralia)

4 Conclusions

The objectives of this study were to improve the yield of the various green ornamentals processed in the packing house. A work planning model was developed to achieve an optimal allocation of the workers, the optimal processing time and work scheduling in each station of the packing house.

The model is simple enough to be understood and implemented by managers and supervisors using readily available spreadsheet programs. An actual process, at a local insurance company handling a moderate daily level of document and payment processing, is used as a case study. The results of the case study yielded an

improvement in the makespan of the current process. The model presented is a useful tool in the document processing industry, is generic enough to be applied to other multi-processor flow shops.

Results show a significant improvement of the yield assisting the farmer to overcome the big shortage of available workers. It proves that employing an analytical scheduling model creates a great advantage and a competing lever in the market. Implementing a simple analytical model in farm daily activities with a large amount of variability is an excellent support to improving productivity and enhances the ability of the farmer to compete in the market.

References

- Alcaide, D., A. Rodriguez-Gonzalez, and J. Sicilia. 2002. An approach to solve the minimum expected makespan flow-shop problem subject to breakdowns, *European Journal of Operational Research*, 140(2): 384-398.
- Arjona, E., G. Bueno, and L. Salazar. 2001. An activity simulation model for the analysis of the harvesting and transportation systems of a sugarcane plantation, *Computers and Electronics in Agriculture*, 32(3): 247-264.
- Bechar, A., D. Dayan, S. Schmilowitch, Y. Moskovitch, and Y. Edan. 2005. A Pocket-Pc-Based Platform for Agricultural Work Study Measurement. In Proc. of the 35th Int. Conf. on Comp. and Ind. Eng., pp. 269-274. Istanbul, Turkey.
- Bochtis, D. D. 2010. Machinery management in bio-production systems: planning and scheduling aspects, *Agricultural Engineering International: CIGR Journal*, 12(2): 55-63.
- Easwaran, G., L. E. Parten, R. Moras, and P. X. Uhlig. 2010. Makespan minimization in machine dominated flowshop, *Applied Mathematics and Computation*, 217(1): 110-116.
- Foulds, L. R., and J. M. Wilson. 2005. Scheduling operations for the harvesting of renewable resources, *Journal of Food Engineering*, 70(3): 281-292.
- Guan, S., M. Nakamura, T. Shikanai, and T. Okazaki. 2008. Hybrid Petri nets modeling for farm work flow, *Computers and Electronics in Agriculture*, 62(2): 149-158.
- Huq, F., K. Cutright, and M. Clarence. 2004. Employee scheduling and makespan minimization in a flow shop with multi-processor work stations: a case study, *Omega*, 32(2): 121-129.
- Johnson, S. M. 1954. Optimal two and three stage production schedules with setup includes, *Naval Research Logistic Quarterly*, 1(1): 61-68.
- Meyers F. E., and J. R. Stewart. 2001. Motion and time study for lean manufacturing (Third Edition), Prentice Hall, New Jersey.
- Pinedo, M. L. 2008. Scheduling: theory, algorithms, and systems, Springer, New York.
- Ruiz-Torres, A. J., J. C. Ho, and J. H. Ablanedo-Rosas. 2011. Makespan and workstation utilization minimization in a flowshop with operations flexibility, *Omega*, 39(3): 273-282.
- Seda, M. 2007. Mathematical models of flow shop and job shop scheduling problems, *World Academy of Science, Engineering and technology*, No. 31, pp. 122-127.
- Tadesse, A., and A. Borowiecki. 1991. A network approved to labour planning in some coffee state farms of Keffa region, *Acta Horticulturae*, 270, pp. 119-126.
- Tavakkoli-Moghaddam, and M. Daneshmand-Mehr. 2005. A computer simulation model for job shop scheduling problems minimizing makespan, *Computers & Industrial Engineering*, 48(4): 811-823.
- Van de Werken. 1990. Labour planning of vegetables growing, *Acta Horticulturae*, 267, pp. 369-377.
- Viswanath, K. G., A. I. Sivakumar, and G. Srinivasan. 2006. Hierarchical minimization of completion time variance and makespan in jobshops. *Computers and Operations Research*, 33(5): 1345-1367.