

Design and calibration of a fuel consumption measurement system for a diesel tractor

H. Fathollahzadeh¹, H. Mobli², A. Jafari², D. Mahdavinejhad², S.M.H. Tabatabaie^{2*}

¹Department of Agricultural Machinery, Islamic Azad University - Shahre-Rey Branch, Iran

²Department of Agricultural Machinery, Faculty of Biosystems Engineering,
University of Tehran, Karaj, Iran

*Corresponding author e-mail: smh.tabatabaie@gmail.com

ABSTRACT

One of the best methods to measure fuel consumption of a tractor engine is using flow meter sensors on the tractor. In this study, a system for measuring fuel consumption was designed. The measurement system was installed on the engine of a 72.3 KW John Deere 3140 tractor. In this system, an electronic board was used to receive and save digital pulses sent by the flow meter sensors. One of the sensors was installed where fuel enters the injector pump, another flow meter was located where fuel returns to the tank. Accuracy of sensors in both the laboratory test and when working in field conditions were compared. Some capabilities of the system are: measuring fuel consumption of the engine in temporal or local circumstances, showing instantaneous fuel consumption, and easy installation without significant effects on the engine under common working conditions.

Keywords: Fuel consumption, Sensor, Flow meter, Tractor, Engineering

1. INTRODUCTION

There are many parameters in agricultural operations affecting fuel consumption of a tractor, such as type and structure of soil, climate, relative humidity, tractor type (two or four wheel drive), tractor size, and the tractor implement relationship. Therefore, tractor fuel consumption values as measured by different methods are not constant and vary from one test method to another (Nielsen and Sorensen, 1993). Measuring fuel consumed by an engine using a direct method can be done in various ways. One method is measuring the fuel in the tank before and after the test operation. But, there are many errors in this measurement, especially when the total fuel consumption in a short test is low. Also Natsis et al. (1999) used a small cylindrical fuel container branched to the main fuel line and equipped with a transparent fuel level indicator to measure fuel consumption. One of the best methods is using flow meter sensors with high accuracy and precision on the tractor. The measurement system should be connected in a way that no problem occurs with fuel entering the system so that measurement accuracy does not decrease (Nielsen, 1987).

Research has been conducted for measuring fuel consumption of a tractor using flow meter sensors. Alimardani (1987) designed a system for measuring and recording effective efficiency factors of a tractor. In this system the fuel consumption of a tractor was measured by two flow

meter sensors (model LS-4150) with appropriate measuring ranges between 2-40 liters per hour and a working accuracy of 1%. For measuring engine fuel consumption, one sensor was placed between the fuel filter and the injector pump and another sensor was located in the line returning fuel from the injectors to the tank. By measuring the amount of fuel passing through each sensor, fuel consumption of the tractor engine was determined. McLaughlin et al. (1993) developed a research tractor as a general purpose research tool, in which a series of sensors and an on-board data logger were fitted for measuring and recording tractor operational parameters such as engine speed, drawbar load, and fuel consumption as the tractor was doing normal field work. In their research the fuel consumption data were mapped. The map showed distinct patterns of varying fuel consumption, and engine power, which were due to field topography, and variability in soil conditions. Yule et al. (1999) developed a data acquisition system to monitor in-field performance of an agricultural tractor. In their research fuel consumption was measured using a MS™ Mk4 fuel flow meter manufactured by JPS Engineering, Birmingham, England. The fuel flow meter consisted of a full flow filter, a 'demand only' fuel pump, a positive displacement flow sensor and a heavily finned fuel return tank. The energy to drive the flow sensor was provided by a slave electrical fuel pump. In this way the fuel measuring system does not influence on the tractor's standard fuelling arrangements in any way. Bedri and Al-Hashem (2006) developed an instrumentation package for monitoring tractor performance. The package included a data acquisition system and transducers for monitoring forward speed, rear wheel speed, fuel consumption and drawbar pull. The instrumentation package developed was mounted on a Fiat DT980 tractor. They used an RS256-225 turbine flow transducer to measure fuel flow rate. The transducer was connected between the main fuel tank and the injector pump for measuring the fuel flowing from the tank. The return fuel from the injector pump and the injectors was cooled via a heat exchanger placed in front of the tractor radiator and then returned to an intermediate vented fuel tank downstream from the fuel transducer. Kheiralla et al. (2007) measured tractor fuel consumption at various tillage depths and speeds by using an oval flow meter sensor.

The flow meter mentioned was located between the injector pump and the fuel filter, and experimental data were saved in an extra memory and were analyzed by transferring them to a computer. So far, there are no detailed studies related to measuring tractor fuel consumption which use flow meter sensors. Also there is not any tractor measuring fuel consumption by flow meter sensors in field operations in Iran. So, in this research a special system was designed and was calibrated to measure tractor fuel consumption.

2. MATERIALS AND METHODS

In the fuel measuring system, two flow meters were used. The flow meter used for measuring input fuel flow to the injector pump was a turbine type (VISION2000), and 6900 pulses were sent for each one liter of the fuel passing through the meter. Some specifications of this sensor were: appropriate working range: 0.1-3 liter per minute, length: 55 mm, weight: 15 g and accuracy: $\pm 0.8\%$ (Fathollahzadeh et al., 2007). Besides, a sensor of the turbine type model (RS256-225) was used to measure the fuel returning from the injectors and the injector pump to the tank with the following specifications: working range: 0.1-3 liter per minute, length: 75 mm, weight: 14 g and accuracy: $\pm 0.9\%$ and 7200 pulses per liter (Fig. 1). So, in addition to the sensor installed where the fuel enters the injector pump, another flow meter was located in the fuel line returning fuel to the tank (Alimardani, 1987). Total engine fuel consumption over a given

distance of operation was calculated as the difference between the readings of the two sensors, and the result was saved in memory. Also, the amount of fuel consumed per second was measured by the measurement system to obtain instantaneous consumption. The related data were displayed by the monitoring unit and saved. Therefore, an electronic board was used to receive and save the digital pulses sent by the flow meter sensors. In this system, a battery (as a power supply), a monitoring unit, a keyboard (for controlling the operation of the system), a memory (for recording data in field operations where sampling and transferring data directly to computer is not possible), a connector for the serial port (for adapting voltage level of the micro controller to a computer) and for the main controller (AVR Atmega16) were used (Fig. 1). Also, the data acquisition schematic diagram and the algorithm of the program are shown in Figures 2 and 3. The measurement system was installed on the diesel engine of a 72.3 KW John Deere 3140 tractor having a mass of 3998 kg.

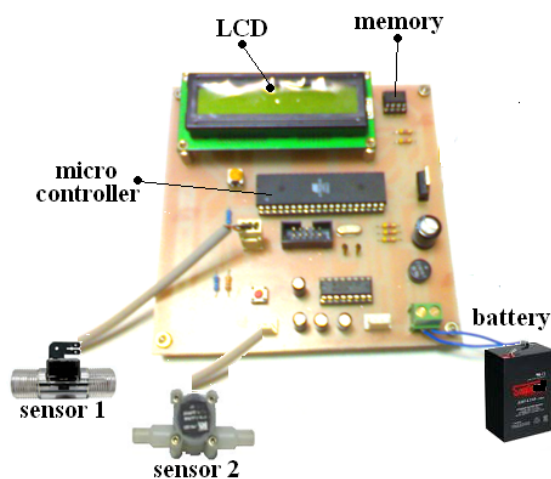

Figure 1. Fuel measuring system.

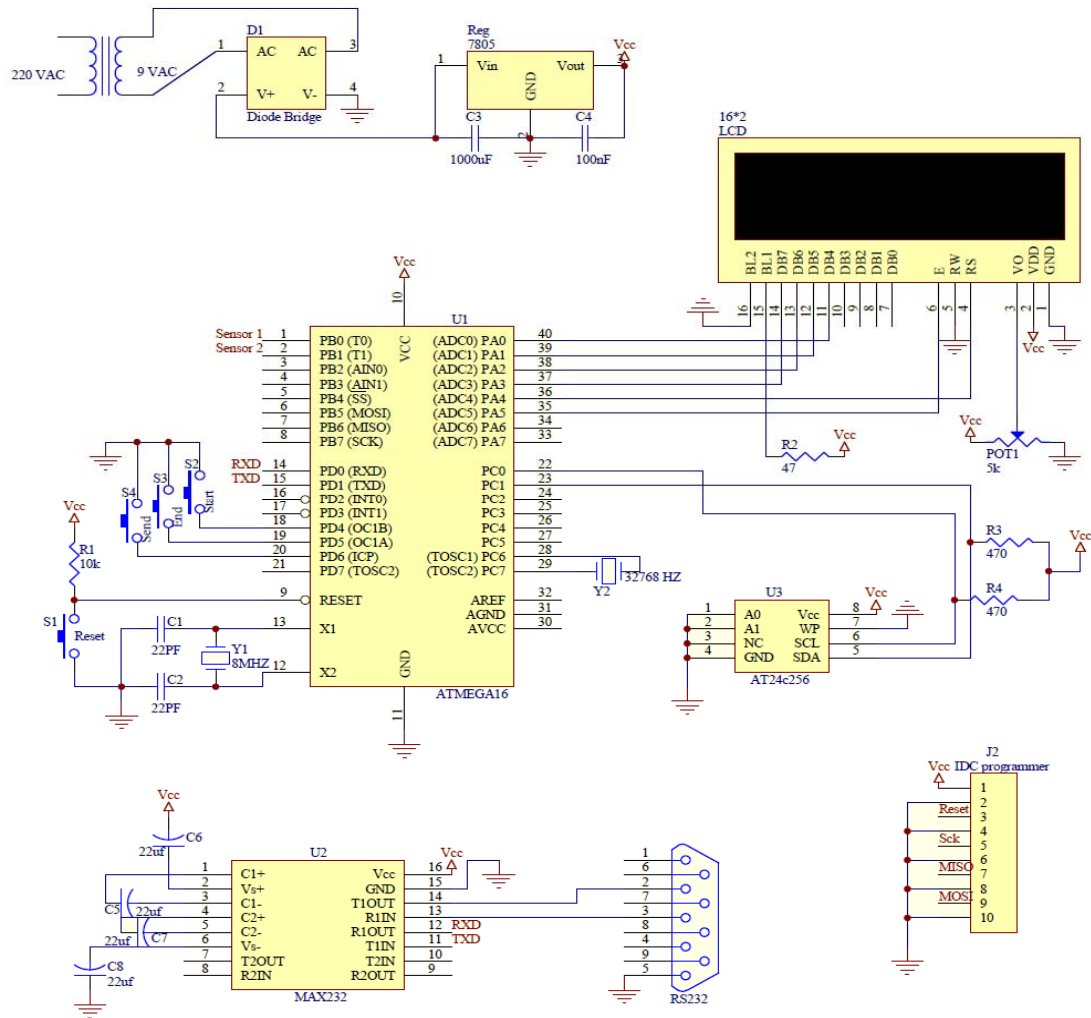

Figure 2. Data acquisition system schematic.

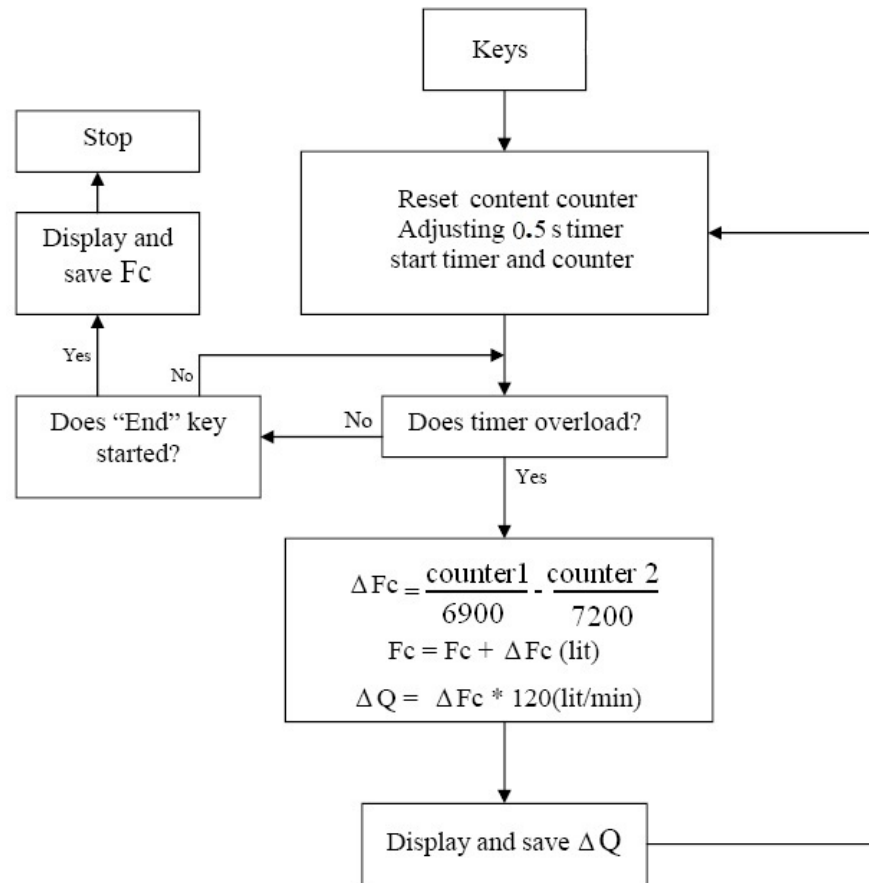

Figure 3. Algorithm to save and display information.

On the first point, an essential parameter to evaluate was the accuracy of the measurement system, which was determined by the mass of flow passed through the flow meters. Also it is clear that a flow meter with an accurate estimate of the fuel amount will be able to show trustworthy values of the fuel flow rate. Therefore, a particular method was used to determine how many pulses were sent by the flow meters per liter (Fig. 2). Two points of fluid surface level were established in the reservoir, and the start and stop buttons for counting pulses from the flow meter sensor were pressed simultaneously with the respective connecting or disconnecting of the exit valve. Then the real volume of fluid exiting from system was measured and the related pulses from sensors were recorded. In addition, according to the number of pulses coming from sensors, the microcontroller calculated the amount of fluid that had passed through the flow meter in liters. Also, this device was used to study the instantaneous flow rate, at the time that the start button was pressed, when the fluid surface reached the fuel level of 1500 ml, and when the stop button was pressed after passing one liter of fluid, at the fuel level of 500 ml in the reservoir.

After that, the accuracy of each of the sensors was calculated based on the error percentage of measurement as determined by eq. 1:

$$\%E = \frac{|V_a - V_e|}{V_a} \times 100 \quad (1)$$

Where:

%E = Measurement error, percent

V_a = Real volume of fuel flowing

V_e = Volume measured by the flow meter

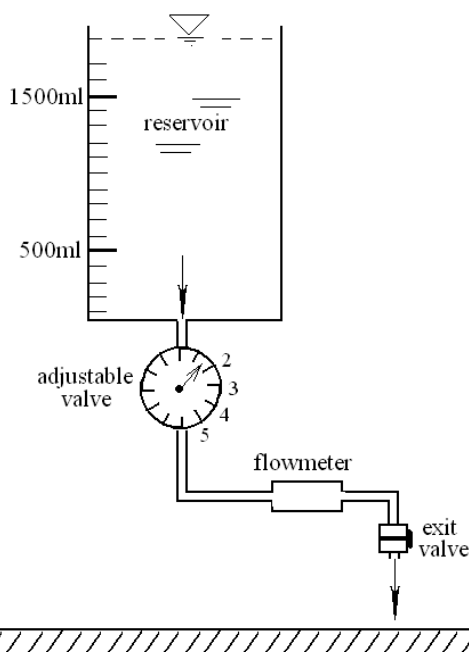

Figure 4. The system for determining accuracy of a flow meter.

Also, it was imperative to determine whether or not the real field conditions under which the tractor would work would have a significant effect on the accuracy of the measuring system. In this regard and owing to the fact that the rate of flow passing through the first sensor would be more than that passing through the sensor in the return line, adjustable-valve settings were used to cover these variable ranges from the minimum to the maximum rate. Besides, this method made it possible to consider and investigate the fuel flow at several rates, both in experimental (testing a single sensor separately) and real conditions (testing a single sensor in contact with the engine in its real position of installation) (Table 1). To determine the average flow of fluid passing through the adjustable valve at four separate adjustable-valve positions, 2, 3, 4 and 5, the volume of fluid exiting from the system in a minute was measured. All experiments were done in September and October when ambient temperature was around 20 degrees Centigrade.

Adjustable-Valve Setting	2	3	4	5
Flow (l/min)	0.14	0.28	0.52	1

One of the methods for studying the effects of vibration and other parameters in real tractor working conditions on accuracy was to put the system and flow meters in contact with the engine while it was running (Fig. 5). Meanwhile, flow from the reservoir after adjusting the adjustable valve to several settings, passed through the flow meter and the accuracy determination results were estimated and were compared with those gained from the tests under laboratory conditions.

Duncan's Multiple Range test at 5% probability was performed to compare the mean values of different treatments by using the computer software SPSS 12.0 (Version, 2003).



Figure 5. A view of a flow meter in contact with the engine to study the effects of vibration.

Because the first sensor before the injector pump had to work under the pressure of the fuel delivery system, the VISION2000 flow meter was selected to be installed in this location, because according to its specifications it was able to work at pressures up to 25 bars. Also, there was not the same high-pressure requirement for the other sensor in the return line to the tank.

In addition, as the rate of fuel flow passing through a pipe is in proportion to the volume per unit time, with an accurate amount of fuel volume passed in a specific time, the flow rate could be calculated. So, in this measuring system the microcontroller received the pulses from the flow meters, and difference between them per second was sent to the monitoring and memory units to show and save, respectively.

Finally, to measure the accuracy of the sensors after they were placed in the fuel delivery system lines, a scaled cylindrical vessel with a capacity of 20 liters was used instead of the tractor fuel tank. In fact, fuel consumption was measured simultaneously with the scaled cylindrical tank and with the flow meters. While the tractor was operating, fuel entered the fuel pump from the scaled vessel and was pumped to the system. In addition, the return line to the tank was disconnected, and the return fuel was transferred to the scaled vessel. At the beginning of the operation the scaled vessel was filled by diesel fuel to a certain height so that at the end of operation the measuring of the remaining fuel in the vessel allowed computation of the amount of consumption. In the whole time of the test, it was not necessary to disconnect the fuel lines from the scaled vessel; otherwise the system would need bleeding. Finally, testing operations were done in three replications using a three-share disc plow with a working width 1.4m and a depth of 15cm. At the end of the test fuel consumption per hectare which had been measured simultaneously by both the sensors and scaled vessel mentioned were compared.

3. RESULTS AND DISCUSSION

Results showed that the two sensors which were installed before the injector pump and before the tank sent 6900 and 7200 pulses per liter, respectively. Also, Tables 2 and 3 show the

accuracy of the sensors as based on the percentage of error at settings 3 and 4 of the adjustable valve for flow meter sensor (VISION 2000) and 2 and 3 for the (RS256-225) sensor in the laboratory and when installed on the tractor engine. These results came from testing the sensors before they were placed in lines of the fuel delivery system. Information in Table 2 represents results after the meters were tested by the accuracy-determination system in Figure 4, without any contact with the engine. Whereas, Table 3 shows results that came from testing with the same system but with the flow meters in contact with the engine.

Table2. Mean error percentage of sensors in laboratory conditions

	Setting 2	SD	Setting 3	SD	Setting 4	SD
VISION 2000	-	-	0.837	0.723	0.738	0.43
RS256-225	0.884	0.5	1.321	0.45	-	-

All values are averages of 10 replications

Table3. Mean error percentage of sensors in contact with the engine

	Setting 2	SD	Setting 3	SD	Setting 4	SD
VISION 2000	-	-	0.955	0.341	0.798	0.424
RS256-225	1.541	1.02	1.27	0.3	-	-

All values are averages of 10 replications

Statistical analysis showed that for different settings of the adjustable valve there were no significant differences at 5% probability between the mean values of error percentage for the two flow meters in the laboratory and when the flow meters were attached to the running engine. In addition, as can be seen in Figure 6, there are acceptable linear relationships between the real volume and the volume measured by the flow meter sensors at each of two selected flow rates as set on the adjustable gauge, when the meters were in contact with the engine in order to detect how engine vibration might affect flow-meter performance. Alimardani (1987) used the same type of diagrams to investigate flow meter performance of a fuel measurement system.

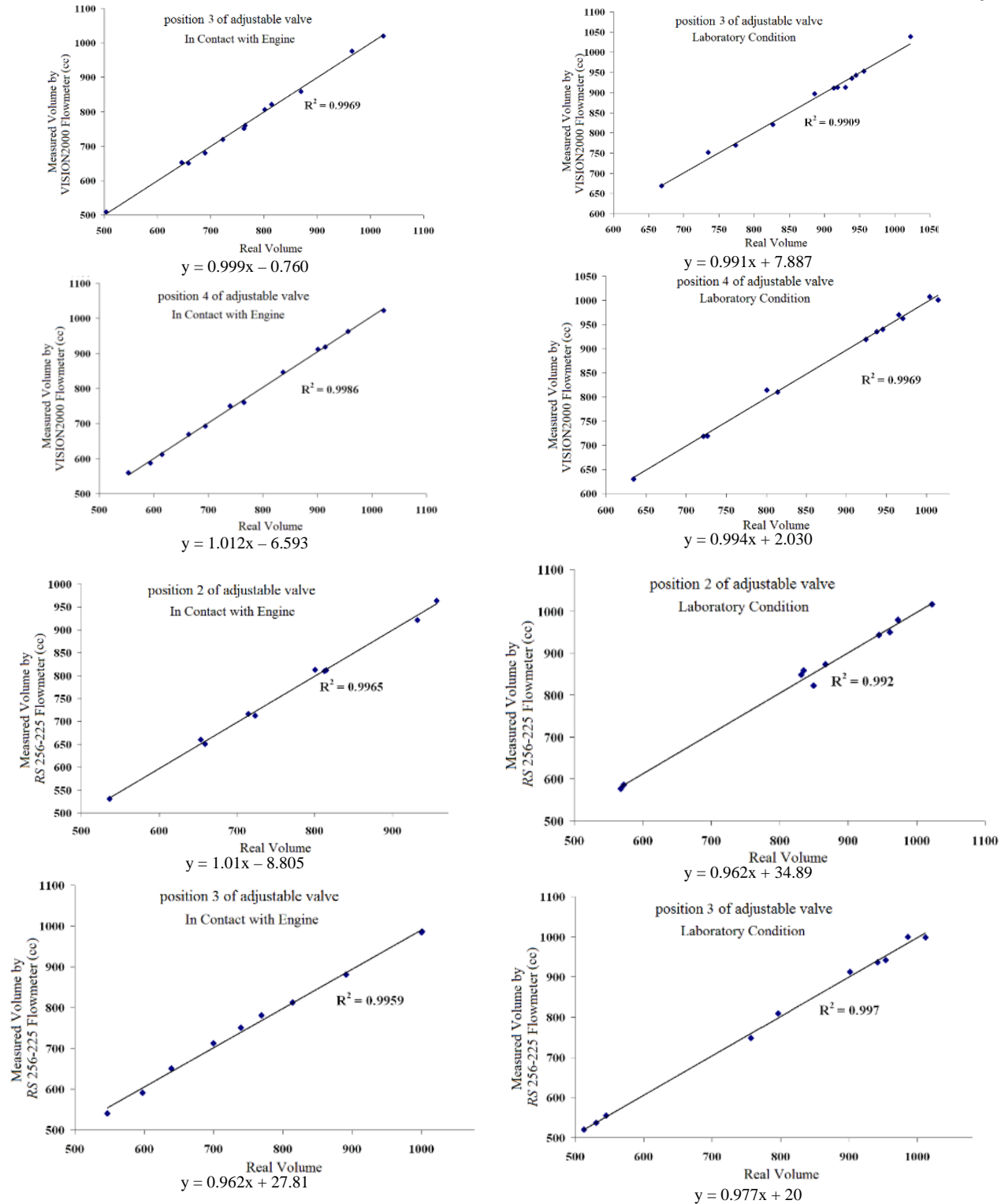

Fig. 6. Diagrams and regression equations for real volume and flow-meter measured volume.

In a study by Hansson et al. (2003) a methodology for measuring the effect of transient loads on fuel efficiency of agricultural tractors was considered. They developed a system for measuring fuel consumption which used a flow meter sensor (VAF Instruments B.V., Dordrecht, the Netherlands) M31C consisting of four radial pistons linked to a crankshaft with an incremental

pulse encoder. The transducer gave 250 pulses/ml with an accuracy of 0.5%, and the measurement range was from 0 to 40 l/h. Alimardani (1987) designed a system for measuring and recording effective efficiency factors of tractors. In this system fuel consumption of a tractor was measured by two flow meter sensors (model LS-4150) with an appropriate measuring range between 2-40 liters per hour and a working accuracy of 1%. Bedri and Al-Hashem (2006) used an RS256-225 turbine flow transducer having a range of 3-90 l/h to measure fuel flow rate, but they did not mention the accuracy of the system.

The instantaneous flow rate as measured by flow meter sensors, both in the laboratory and when the sensors were connected to the engine, was studied, and a sample of the results is shown in Figure 7 for the VISION2000 flow meter. As was indicated, there was no significant change in flow rate in either condition, and this could increase confidence in the reliability of results which would come from the flow meters when they were in use for fuel measurement on operating tractors.

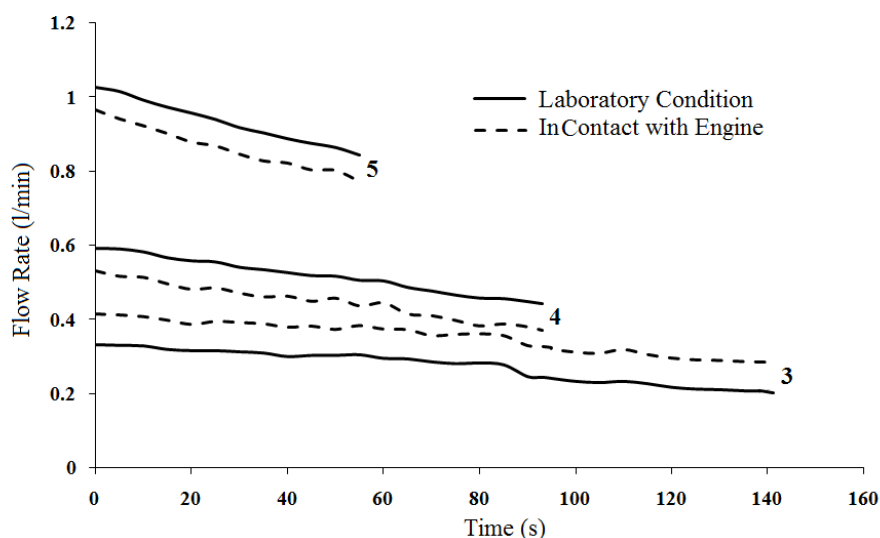

Figure 7. A sample of instantaneous flow rate for one liter of fluid passing through a VISION2000 flow meter at 3 settings of the adjustable valve. Note: each of the adjustable valve settings was for a general range of flow rates and may have been slightly different in the laboratory test condition than in the engine-contact test condition, the purpose here is to show similarity of characteristics for the two cases.

Field operations using a three-share disc plow were conducted to study the accuracy of the installed sensors, and showed that the measured fuel consumption by the sensors and that measured with the direct method using a scaled vessel were 19.667 and 19.90, respectively. Therefore, the measuring system had an accuracy that could be represented by an error percentage of 1.17%.

4. CONCLUSION

- The design and fabrication of the fuel measurement system cost less than \$500. Also, installation of the system was not complicated, and it was possible to install the system on the tractor in approximately 15 minutes.
- In spite of the fact that it is appropriate to measure the amount of fuel consumed in a given distance of tractor operation, a diagram of instantaneous fuel consumption can be monitored, which is a good way to study how soil density, structure, texture and many other variables and instantaneous parameters affect tractor fuel consumption on a continuous basis in field operations.
- The approximate accuracy of the system is about 2%, as based on the percentage of error found, and this figure might be improved if high quality, accurate flow meters are used. In addition the primary pump in the fuel delivery system caused fluctuation in the flow of fuel, and this might have had a negative effect on flow meter performance. So, it would be better if an electric pump could be used instead. Besides, using one sensor instead of two can definitely increase system accuracy. It is possible by joining the return fuel line to the fuel source line just prior to the primary injection pump, to make it possible for one fuel flow sensor to measure the net fuel consumption. So, if the flow meter is installed before the junction with the return line, total fuel consumption will be measured. Although this procedure could make system accuracy better by removing one of the sensors, increasing fuel temperature might have a negative effect on tractor performance under common working conditions.

ACKNOWLEDGEMENTS

The authors wish to thank the Department of Agriculture Machinery Engineering, Faculty of Bio-system Engineering, University of Tehran for its support. Also, we express our deep appreciation to Nazanin Yadollahi Bastani for her help.

REFERENCES

- Alimardani, R., 1987. A computer based instrumentation system for measuring tractor field performance. PhD Thesis, Iowa state university, Ames, Iowa.
- Bedri, A-R A., & Al-Hashem, H A. S., 2006. High Precision Instrumentation Package for Monitoring the Tractor Performance. Scientific Journal of King Faisal University (Basic and Applied Sciences), 7, 95- 106.
- Hamzeh Fathollahzadeh, Hossein Mobli, Ali Jafari, Davood Mahdavinejad., 2007. Designing and fabricating an instrument for monitoring fuel consumption of agricultural machinery. Accepted for oral presentation in International Agricultural Engineering Conference. IAEC ref. 520. 3 – 6 December 2007. Bangkok, Thailand.
- Hansson, P.A., Lindgren, M., Nordin, M., and Pettersson., O., 2003. A methodology for measuring the effects of transient loads on the fuel efficiency of agricultural tractors. Applied Engineering in Agriculture 19(3), 251–257.
- Kheiralla, A.F., Yahya, A., Zohadie M., and Ishak, W., 2007. Modelling of power and energy requirements for tillage implements operating in Serdang sandy clay loam, Malaysia. Soil & Tillage Research 78, 21–34.

- McLaughlin, N.B., L.C. Heslop, D.J. Buckley, G.R. St.Amour, B.A. Compton, A.M. Jones and P. Van Bodegom., 1993. A general purpose tractor instrumentation and data logging system. *Transactions of the ASAE* 36 (2), 65-273.
- Natsis, A., Papadakis, G., and Pitsilis, J., 1999. The Influence of Soil Type, Soil Water and Share Sharpness of a Mouldboard Plough on Energy Consumption, Rate of Work and Tillage Quality. *J. Agric. Engng Res* 72, 171-176.
- Nielsen, V. and C.G. Sørensen., 1993. Technical Farm Management a Program for Calculation of Work Requirement, Work Capacity, Work Budget, Work Profile (in Danish with English summary). Danish Institute of Agricultural Engineering: Report No. 53, 124 p.
- Nielsen, V., 1987. Tractor Equipment Informing of Optimum Utilization of Fuel and Operational Financing as Regards Tractors, Implements and Tractor Drivers (in Danish). Danish Institute of Agricultural Engineering: Information Sheet No. 72, 41p.
- Yule, I.J., Kohnen, G., and Nowak, M., 1999. A tractor performance monitor with DGPS capability. *Computers and Electronics in Agriculture*, 23, 155–174.