

MODIFICATION AND PERFORMANCE EVALUATION OF TRACTOR DRAWN IMPROVED TILL PLANT MACHINE UNDER VERTISOL

Atul Kumar Shrivastava* and Satyendra Jha**

Department of Farm Machinery and Power Engineering, College of Agricultural
Engineering, JNKVV, Jabalapur, M.P.-482004, INDIA

ABSTRACT

A tractor drawn (TD) till plant machine was designed and developed with the help of computer aided design package for adoption of minimum till technology by the farmers, in black cotton soil conditions. This machine was evaluated and compared with the performance of a zero till drill and conventional practices at Jawaharlal Nehru Agricultural University farms as well as at a farmer's fields. It was found that the total time and cost required for tillage and sowing operations by till plant machine was 5.09 h/ha and Rs. 410.37/ha, which is 72.23 per cent less time required than conventional practices of wheat cultivation but is 28.83 per cent more time required than zero till drill practices. The average yield by tractor till plant machine was 26.96 q/ha, whereas, by conventional practices and tractor drawn zero till drill was 25.91 and 22.72 q/ha. respectively. The soil conditions were also found better in the case of the T.D. till plant machine.

INTRODUCTION

Tillage is a major time and energy consuming crop production operation. Timelines of field operations becomes a problem under rain fed farming for introducing the second crop, when human labor and draft animals are the major source of farm power. This situation is worst in the vertisol (black cotton soil) even if tractor farm power is available because, there is a very limited time gap available between harvesting of the paddy and sowing of Rabi crops. Reduced tillage not only conserves the time and energy, but also reduces the cost of cultivation, improves soil environment for better crop yield and increased water availability for plant growth Sandhu, 1981 reported that wheat could be grown after paddy without any tillage operations. Shukla (1987 and 2001), Shrivastava (2005) and Choudhary (2002) reported that the performance of strip, zero and conventional till system for wheat cropping gave better results in the light soil.

*Atul Kumar Shrivastava and Satyendra Jha. Modeling and performance evaluation of tractor drawn improved till plant machine under vertisol. Agricultural Engineering International: the CIGR Journal. Manuscript No.1260. Vol. 13. Issue 2, June, 2011.

METHODS AND MATERIALS

The machine consists of a 9 tine seed-cum-fertilizer drill. The machine was designed with an AutoCAD 2006 Computer graphic package. The conceptual and orthographic design views of the duck foot shovel as well as isometric & orthographic design views the machine are given fig 1, 2 & 3. The overall specifications of the machine are given in table no. 1.

Duck foot shovel type furrow opener description

The duck foot shovel type furrow opener (Fig.3) consists of a tine, a shovel, a boot and tubes for seed and fertilizer. Tine should be made of flat mild steel flat having a width of 55 to 75 mm and thickness of 15 to 18 mm. Boot and tube should be made of mild steel with a minimum thickness of 1.8 to 2.0 mm and shovel material should be high carbon steel having minimum carbon content of 0.5 % . The shovel should be heat-treated with minimum hardness in the range of 350 to 450 HB. Thickness of shovel should be 3.0 to 4.0 mm. The furrow opener tines are made of mild steel while the shoe or shovel of the opener are made of wear resistant high carbon steel (0.5 to 0.6% C, 0.65 % S and 0.05 % P).

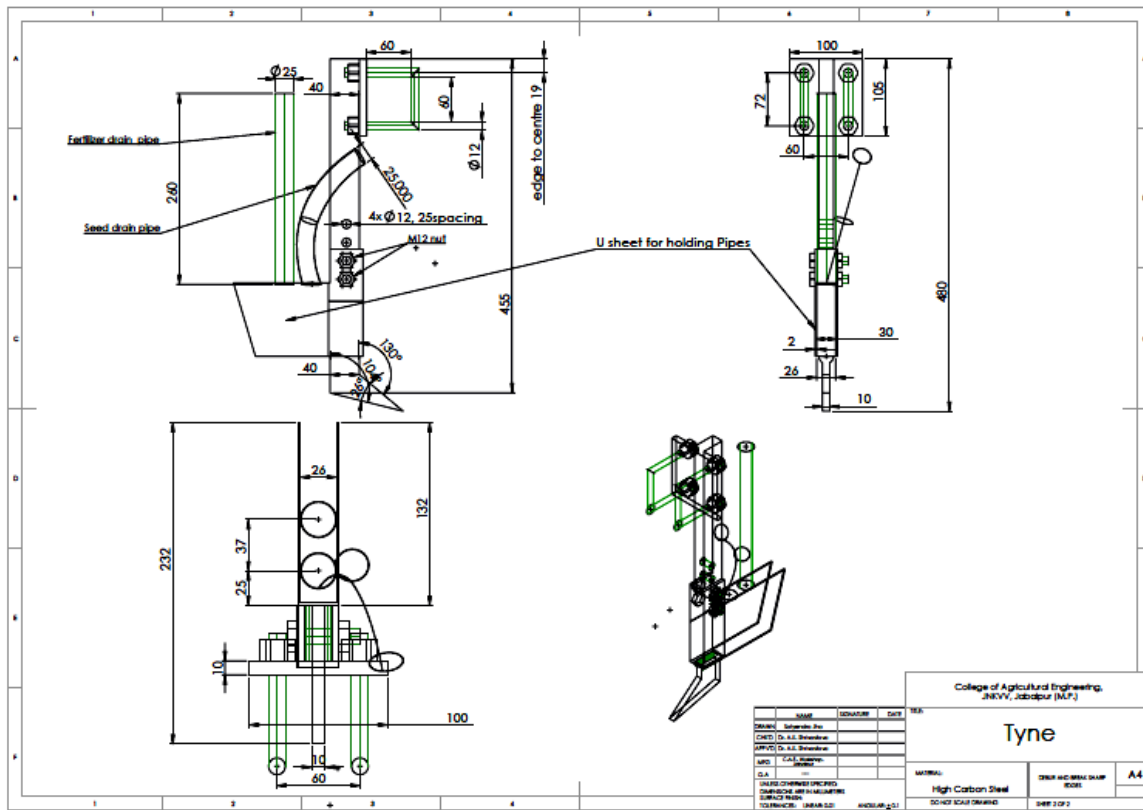

Figure 1. A view of Duck foot shovel & tine

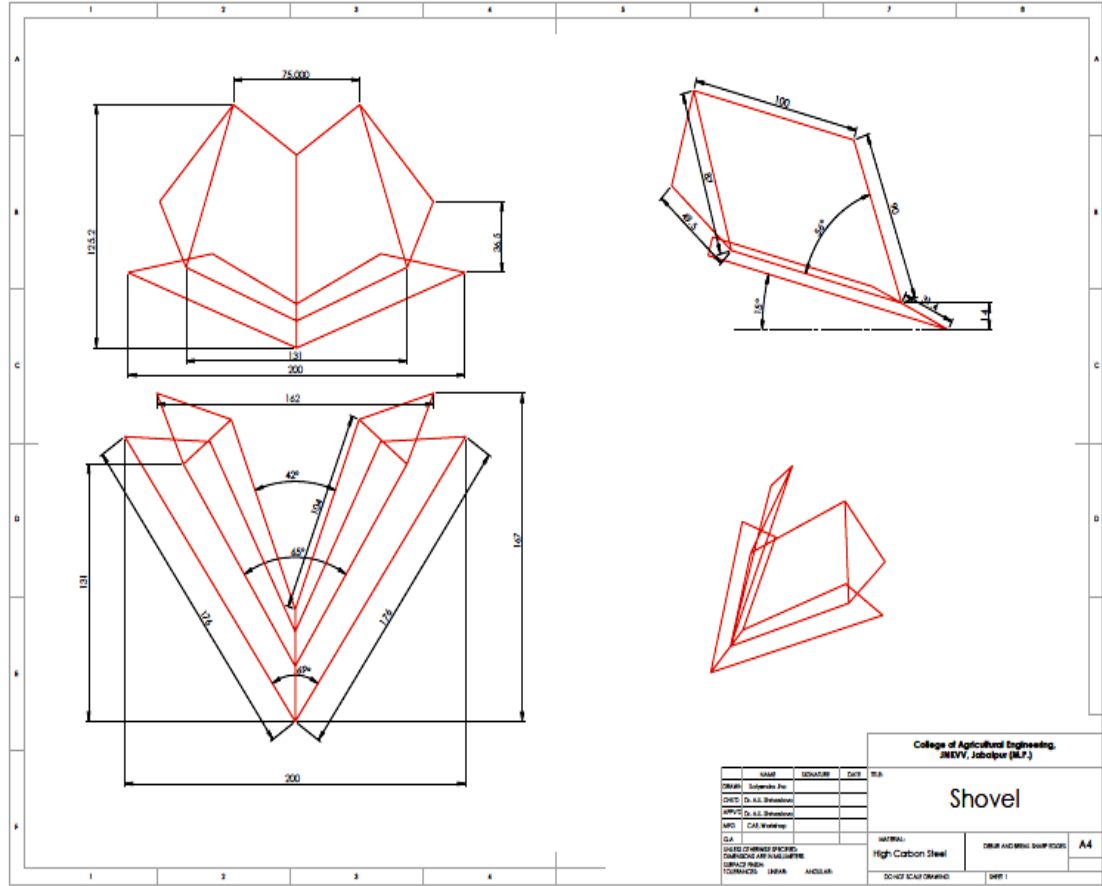

Figure 2. Detail dimension of duck-foot shovel

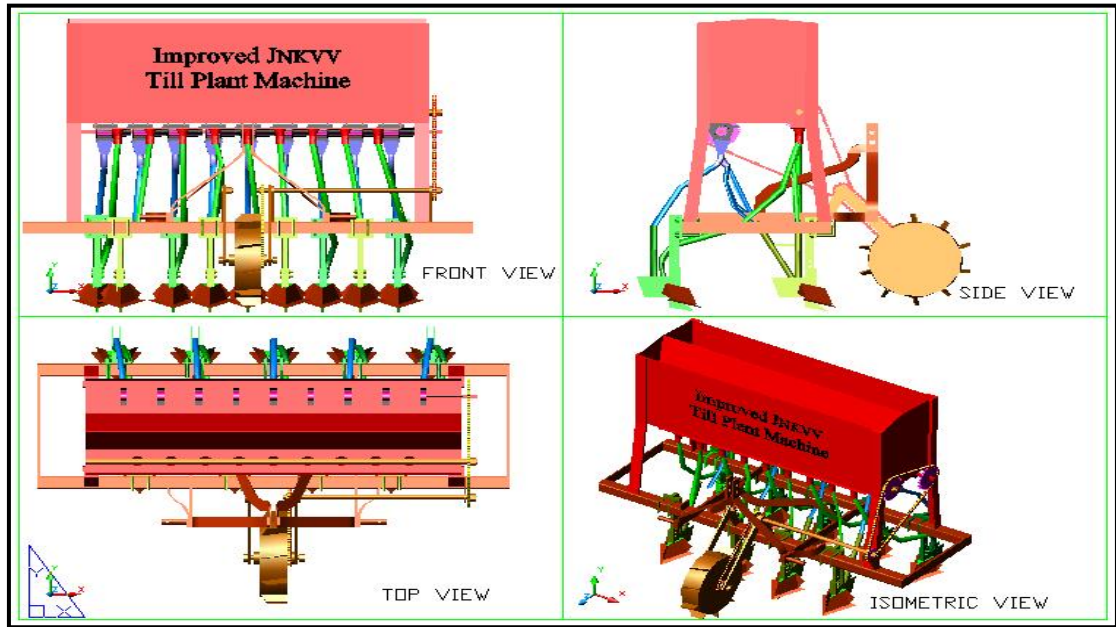

Figure 3. Isometric and orthographic view of the complete Improved Till Plant Machine

The minimum diameter of seed and fertilizer tubes should be 50 mm and they should be so placed that centre to centre distance between seed and fertilizer tubes be minimum 50 mm. The lower tip of the fertilizer tubes should be 10 mm below the tip of the seed tubes and should be minimum 25 mm above the lowest point of boot.

Design of tine of the furrow opener

The shape of the tine (Fig. 4) is determined by slope l_1 and the radius of curvature R , which is dependent on load angle α of shovel. Thus,

$$R = \frac{h_0 - l_1 \sin \alpha}{\cos \alpha} \quad \text{----- eq (1)}$$

The length of the inclined part of the tine generally ranges from 100 to 200 mm, and the radius of curvature $R < 120$ mm. The minimum clearance H_1 between the land surface and the lower edge of the frame should be 200 mm. Height of the tine is given by:

$$H = a_{\max} + H_1 + H$$

The tine of the furrow opener is exposed first of all to bending in consequence of soil resistance. The soil resistance (F_0) is horizontal and acts in the axis of symmetry of shoe or shovel. The soil resistance is assumed to be 3 to 5 times higher than actual average soil resistance (F_x) offered by the particular soil. The value of the actual average soil resistance is obtained by the formula:

$$F_x = a W_w P_k \quad \text{----- (eq 2)}$$

Stress, causing the time to bend is given by the expression:

$$\sigma = \frac{6F_0(H_1 + a)}{b_1 t^2} \quad \text{----- (eq 3)}$$

Torsional stress acting on the tine when turning the openers inside the soil at headland is given by.

$$\tau = \frac{9F_0 W_w}{8t b_1^2} \quad \text{----- (eq 4)}$$

Reduced stress amounts to

$$\sigma_{zx} = \sqrt{\sigma^2 + 4\tau^2} \quad \text{----- (eq 5)}$$

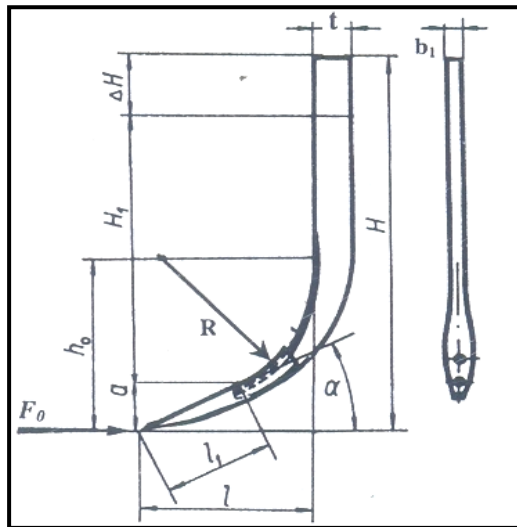

Figure 4. Dimension of tine of furrow opener.

Since, the tine of the furrow opener is sinking into the soil, thickness should be kept to a minimum. The most assumed ratio of thickness to width of tine is taken as 1:3 to: 4.

The performance of the tractor drawn improved till plant machine was evaluated in 2.5 ha fields at JNKVV farms and a local farmer's with vertisol soil just after the harvesting of paddy crops. The machine performance was compared with the conventional practices and zero tillage drill for wheat cultivation. A 20 x 75 meter plot was used for each treatment There were 5 replications for each treatment. Details of the treatments are given below:

T₁ = Tractor Drawn cultivator x 1 + Disc harrow x 1 + seed drill x 1.

T₂ = Tractor drawn zero till seed cum-fertilizer drill

T₃ = Tractor drawn till plant machine

Table 1. Specification of Tractor Drawn Improved Till Plant Machine

S. No.	Particulars	Size
1.	Length (mm)	1780-2075
2.	Width (mm)	480-565
3.	Height (mm)	1070-1275
4.	Seed Metering Mechanism	Fluted roller type
5.	Fertilizer Metering Mechanism	Gravity feed or corrugated roller type
6.	Power transmission	Through chain & sprocket
7.	Furrow openers	Duck foot shovel type
8.	No. of Furrow openers	9
9.	Size of feed shaft (mm)	16-18
10.	Size (diameter) and no. of flutes	42.07(approx.) & 9
11.	Diameter of fluted roller (mm)	42.07(approx.)
12.	Size of fertilizer shaft (mm)	20-22.5
13.	Ground wheel diameter(mm)	390-450

The performances were evaluated on the basis of field capacity, time required for tillage and sowing, cost of operations and yield. The soil physical parameters were also measured before and after the tillage operations. JNKVV Improved till plant machine was used for tillage as well as the sowing operation under the black cotton soil for the wheat crop in an untilled field after harvesting of the paddy.

RESULTS AND DISCUSSION

The Table 2 shows the average performance results of all three systems for the last two years. It was revealed from the table that maximum time was with T₁ at 11.65 h/ha and minimum was T₂ with 5.06 h/ha followed by T₃ i.e.5.09 h/ha. This means that conventional practices required 72.27% more time than T₂ and 72.32% more than T₃, when the sowing was conducted just after the harvesting of the paddy crop. T₁ took extra time for the first irrigation, the tillage operation and then sowing operations. The total days required for tillage and sowing operations by T₁ treatment was between 12 to 15 days, while T₂ and T₃

(tillage and sowing operations were conducted simultaneously) required 2 days just after the harvesting of the paddy. The field capacity was measured for each treatment (Table 2) but it was not compared due to the different width of implements and the number of operations for each system. The cost of operation was found minimum in the case of T₂ with Rs. 1899.56 /ha. For T₃ and T₁ it was Rs. 1930.37 and Rs. 2670/ha respectively, which included cost of seed and fertilizer also. The cost of operation was minimum with T₂ because this treatment (zero till drill) completed the tillage and sowing operations simultaneously at a shallow depth, and didn't turn the soils and stubbles under the paddy harvested fields. Treatment T₁ required a higher number of operations as well as time. The treatment T₁ also required one to two more irrigations, which increased the production cost of wheat. The yield obtained by T₁, T₂, and T₃ were 25.61, 24.72 and 26.89 q/ha respectively. This shows that the zero till drill (with inverted furrow openers) didn't work satisfactorily as compared to the duck foot shovel furrow openers under black cotton soil, soon after paddy harvesting. The weeding efficiency was also calculated for each treatment and found to be 71.98%, 27.37 and 91.3% weeding efficiency by T₁, T₂ and T₃ Treatments. This is also one of the reasons for obtaining the low yield in the case of treatment T₂. Fig 5, 6 and 7 show views of field operations and crop yield.

Table 2. Performance results of different machines.

S. No	Particulars	Treatment 1			Treatment 2	Treatment 3
		Cultivator x1	Disc harrow x 1	Seed drill	Zero Till ferti seed drill	Till plant machine
1	Date of test	05 - 12 - 05	05 - 12 - 05	05 - 12 - 05	07-12-05	12 - 12 - 05
2	Topography of soil	Plain	Plain	Plain	Plain	Plain
3	Type of soil	Clay loam	Clay loam	Clay loam	Clay loam	Clay loam
4	Plot size, hectare	0.15	0.15	0.15	0.15	0.15
5	Av. Moisture content of soil, %	25.37	23.1	21.37	18.57	16.14
6	Av. Depth of cut, cm	10.34	9.82	9.13	7.5	101.6
7	Av. Width of operation, cm	189	210	185	126.0	205.74

8	Av. Speed of operation, km / h	2.89	4.80	5.98	5.64	3.8
9	Duration of test, h / ha	11.65			5.06	5.09
10	Field capacity, ha / h	0.48	0.34	0.47	0.497	0.489
11	Theoretical field capacity, ha / h	0.594	0.510	0.66	0.66	0.621
12	Field efficiency, %	81.3	68.9	72	75.03	78.74
13	Weeding efficiency, %	66-72	70-82	-	23.5	92.12
14	Fuel consumption, lit / ha	33.56			11.08	12.04
15	Cost of operation, Rs. / ha ,	377.06	421.80	351.14	379	410.37.
16	Total yield, q / ha	25.61			24.72	26.98

1. Total input cost of T_1 = cost of tillage (i.e. Rs 377.06 + 421.80) + sowing (i.e. Rs 351.14) + cost of seed (i.e. Rs 1100) + cost of fertilizer (i.e. Rs 420) = Rs 2670.26/ha
2. Total input cost = cost of tillage + sowing (i.e. Rs 379.56) + cost of seed (i.e. Rs 1100) + cost of fertilizer (i.e. Rs 420) = Rs 1899.56 / ha
3. Total input cost = cost of tillage + sowing (i.e. Rs 410.37) + cost of seed (i.e. Rs.1100) + cost of fertilizer (i.e. Rs.420) = Rs 1930.37 / ha

The soil physical parameters of the vertisol were also measured before and after operations of each treatment and are given in table 3.

It was found that the soil bearing strength (cone index in kPa) was reduced more in the case of the Improved Till Plant Machine. The Cone Index obtained before operation was 2399.5 kPa for T_1 , 2411.5 kPa for T_2 and 2493.7kPa for T_3 respectively, whereas, after the operations T_1 , T_2 , T_3 , were found to be 1002.7, 1043.13, &1012.3.kPa respectively. It shows that the Till plant machine action with Duck Foot Shovel gave better pulverization than other passive tools. The bulk density of untilled land was measured & found to be 1.79 g / cc for T_1 , 1.73 g / cc for T_2 , and 1.74 g / cc for T_3 respectively. After operation it was found that the bulk density was 1.06 g / cc for T_1 , 1.37 g / cc for T_2 and 1.17g / cc for T_3 respectively.

Table 3 Result of the different treatment

S. No.	Particulars	T ₁	T ₂	T ₃
1	Moisture Content of Soil, %	19 to 26.3	14.73 to 19.13	14.87-18.63
2	Av. cone index before operation, kPa at 2” depth	2399.5	2411.5	2493.7
3	Av. cone index after operation, kPa at 2” depth	1002.7	1043.13	1012.5
4	Bulk density before operation, gm/cm ³	1.79	1.73	1.74
5	Bulk density after operation, gm/cm ³	1.06	1.37	1.17
6	Av. Mean weight diameter of soil after operation, mm	3.9	4.47	4.39

In the soil physical parameters point of view, for better wheat crop growth, the treatment T₃ is superior to other treatments. The mean weight diameter (MWD) of soil was found after the operations to be 3.92, 4.47 and 4.39 mm for T₁, T₂ and T₃ respectively.



Figure 5 View of the field operation of T₂



Figure 6. View of the field operation of T₃



Figure 7. Crop yield by using Improved Till Plant Machine

1. The result of the testing shows that the improved till plant machine gave problem free and better performance than the other conventional sowing treatments.
2. The time required for completing the work by tractor drawn cultivator x 1 + Disc harrow x 1 + seed drill x 1 was 72.27% higher than tractor drawn zero till seed cum-fertilizer drill, and 72.32% more than tractor drawn till plant machine. The operation cost was found to be minimum in case of tractor drawn zero till seed cum-fertilizer drill i.e. Rs. 1899.56 which is 28.86% less than tractor drawn cultivator x 1 + Disc harrow x 1 + seed drill x 1 and almost equal to tractor drawn till plant machine. The

yield was obtained in case of treatment tractor drawn till plant machine i.e. 25.89 q/ha, which is slightly more than tractor drawn cultivator x 1 + Disc harrow x 1 + seed drill x 1. and tractor drawn till plant machine i.e. 25.61, 24.72 q/ ha respectively. Therefore, tractor drawn till plant machineries recommended as the best treatment among others .

3. Farmers can perform seed bed preparation and sowing operations simultaneously and can conserve time, fuel irrigation and manpower with a reduction in the cost of operation, by using the tractor drawn improved till plant machine.
4. In a double cropped situation due to late harvesting of the paddy, the wheat is generally sown late as the field conditions don't permit conventional tillage and sowing. In some cases direct drilling has special significance for timely planting of wheat for better establishment growth and yield.
5. The Auto CAD computer software package is a very powerful, helpful & precise tool for drawing, drafting & 3-D visualization of the objects with technical considerations before manufacturing.

REFERENCES :

- Choudhary, V. P. and Singh, B. (2002). Effect of zero, strip and conventional till system on performance of wheat. *J. of Agricultural Engineering* vol. 39/2, 27-31, April-June. 2002.
- Deevani, R.S. (1991). Agricultural machinery design and data hand book seeders & planters. *In: Regional Network for Agric. Machinery of United Nations Development Programme, Bangkok, Thailand.*
- Dubey, A. K. (2003). Design of furrow openers of seed cum fertilizer drills. *In: Proceedings of National Workshop on Design Methodology of Agricultural Machinery. CIAE, Bhopal. pp. 61 – 76.*
- Rautray, S. K. (2003). Design consideration of conservation tillage equipments. *In: Teaching Material for Training on AutoCAD and Design Methodology for Agricultural Machinery. CIAE, Bhopal. pp 28 – 38.*
- Sandhu, G. S. 1981 personal communication Department, PAV Ludhiana, Punjab.

- Shrivastava A.K., C.S. Deshmukh and N. Jain. Design development and performance of T.D. rotavator cum seed drill under vertisol. Paper presented and published in the International Conference of Agricultural Engineering, AAAE, AIT, Bangkok pp 5-9, 2005.
- Shukla, L. N., Dhalwal I. S. and Chauhan A. M.(2001). Multiplication field performance of strip till drill on wheat crop J. of Agricultural Engineering vol. 38/3, 35-39, July-Sep. 2001.
- Shukla, J.N., Chouhan A.M. Dhaliwal I.S., Verma S.R. (1987) Field evaluation of Rotary blade Till attachment for Direct sowing operation, Journal of Agricultural Engineering 29(1) pp. 21-27.
- Singh, G.(1985) Teaching materials on training course on design of agricultural machinery. C.I.A.E, Bhopal, India.
- Singh, R. K. P. and Singh, B. (1998). Effect of different tillage systems on soil properties and yield of wheat. *Agric. Engg. Today J. ISAE*. 22(5 – 6) pp. 1 – 8.
- Varshney A. C., Singh, A. K. and Naik, R. K. (2004). “Design data on seed drill” chapter in Data book for Agricultural Machinery Design, CIAE, Bhopal, pp. 233-241.