

Proceedings of the 6th International Conference on the Application of Physical Modelling in Coastal and Port Engineering and Science (Coastlab16)

Ottawa, Canada, May 10-13, 2016

Copyright © HR Wallingford: Creative Commons CC BY-NC-ND 4.0



COMPARISON BETWEEN METHODS FOR CREATING DEMS OF PHYSICAL MODELS

DAVID TODD¹, JAMES SUTHERLAND², NEIL CROSSOUARD³, RICHARD RANKINE⁴, TOM RIGDEN⁵, RICHARD WHITEHOUSE⁶

1 HR Wallingford, UK, d.todd@hrwallingford.com

2 HR Wallingford, UK, j.sutherland@hrwallingford.com

3 HR Wallingford, UK, n.crossouard@hrwallingford.com

4 HR Wallingford, UK, r.rankine@hrwallingford.com

5 HR Wallingford, UK, t.rigden@hrwallingford.com

6 HR Wallingford, UK, r.whitehouse@hrwallingford.com

ABSTRACT

Within physical modelling, it is often necessary to create DEMs (digital elevation models) when testing the stability of rock structures or the filter layers and scour protection around foundations and other marine structures. These DEMs are used to detect changes in the position of the structure or surrounding protective material. Several methods are available to create these models, yet no one technique has been selected as an industry standard. A comparison between three widely used methods – terrestrial laser scanner (TLS), combined laser scanner (CLS) and structure from motion (SfM) – are presented within this paper. The CLS in underwater mode gave low measurement errors and can be deployed without having to drain the facility but requires a traverser system. An area of approximately 7 m by 4 m can be measured in half an hour. The TLS can survey a much larger area in the same time, but requires the facility to be drained. SfM is cheapest method, but struggles to create a full shape and more care must be taken. The CLS in underwater mode has been chosen for use in scour studies in the Fast Flow Facility, with high volumes of water but a relatively limited area.

KEYWORDS: Physical modelling, laboratory scale modelling, laser scanner, SfM, scour

1. INTRODUCTION

Physical model testing of the stability of rock structures, or the filter layers and scour protection of other foundations and marine structures, is a common element of project design. Typical structures to be tested include rubble mound breakwaters, riprap layers and the scour protection around caissons, monopiles, suction buckets, gravity base structures and novel foundation types. For these tests it is necessary to detect changes in the position of the structure or the surrounding bed, including the armour or filter material. Traditional methods for assessing bed level change and damage to armour layers include the use of:

- Photography, where changes are observed by overlaying before and after photographs to detect differences;
- Photogrammetry, where a three-dimensional digital elevation model can be constructed from multiple images; and
- Bed profiler, which measures elevation at set distances along a profile, allowing changes to be measured;

Failure criteria vary, depending on the structure and mode of failure (CIRIA/CUR/CETMEF, 2007), but are often based on acceptable limits of the loss of armour or exposure of filter along a profile.

The recent development of optical technologies has provided physical modellers with an increasing range of instruments for generating detailed digital elevation models (DEMs) of rock structures. Techniques must be non-invasive, with a sufficiently high spatial resolution and sufficiently low operating duration to provide comprehensive coverage on the order of minutes rather than hours. This paper compares the accuracy of methods for obtaining DEMs of rock and other structures, complements the review by Porter et al (2014) and presents examples of DEMs of scour

protection around a monopile measured using:

1. Terrestrial laser scanner (TLS);
2. Combined laser scanner (CLS – operable in both in air (IA) and underwater (UW) modes);
3. Structure from motion (SfM).

These methods were selected based on their ability to rapidly produce fully three-dimensional DEMs with sub-centimetre accuracy. This paper provides details of the methodology used for these techniques and provides a comparison between them, giving an analysis of their strengths and weaknesses.

2. METHODOLOGY

2.1 Location

Data were collected in the main working channel of the Fast Flow Facility at HR Wallingford, a 75 m long race track shaped flume containing two channels of 4 m and 2.6 m width respectively (see www.hrwallingford.com/facilities/fast-flow-facility/). The flume is able to operate across depths of 0.85-2 m and is capable of producing waves of up to 0.5 m H_s (1.0 m H_{Max}) and current speeds in excess of 2 m/s. Initial data collection for the terrestrial techniques was conducted in the dry, before the flume was filled with water to allow data collection using the underwater method.

2.2 Experimental set-up

A 0.168 m outer-diameter (OD) monopile, surrounded with a circle of crushed limestone rock protection (D_{50} 3.2 mm, D_{90}/D_{10} 2.2), of 0.504 m radial extent and 0.031 m thickness, with a 1:1 slope at the edges giving a total diameter of 1.07 m, was constructed within the main channel of the Fast Flow Facility. Four cuboids of known size and varying colour were placed outside of the rock protection at equidistant points from the centre of the monopile. A solved Rubik's Cube was placed on top of the rock protection at a rotated angle on top of a base unit. Yellow, red, blue and silver cuboids were selected to allow the response of each measurement method to a variety of colours to be investigated. The Rubik's Cube provided a further, more complex coloured surface, with the yellow, blue and red surfaces the most visible. A schematic of the layout of targets within the flume is given in Figure 1, with details of a cuboid in Figure 2.

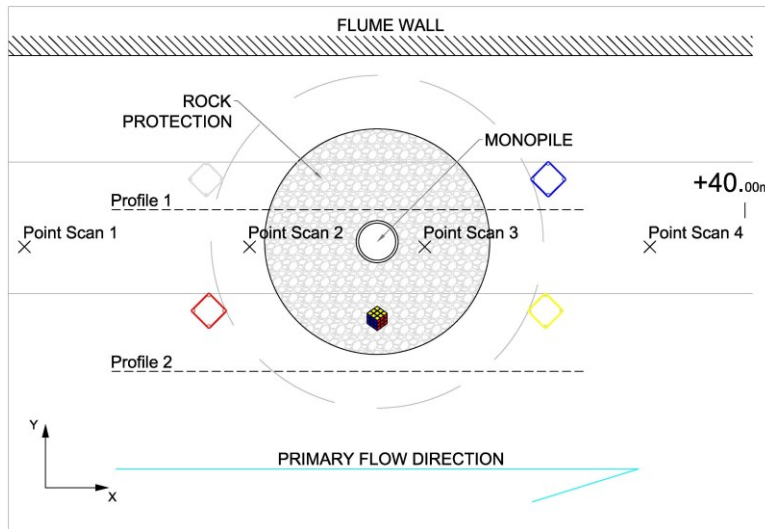

Figure 1. Layout of objects within the Fast Flow Facility

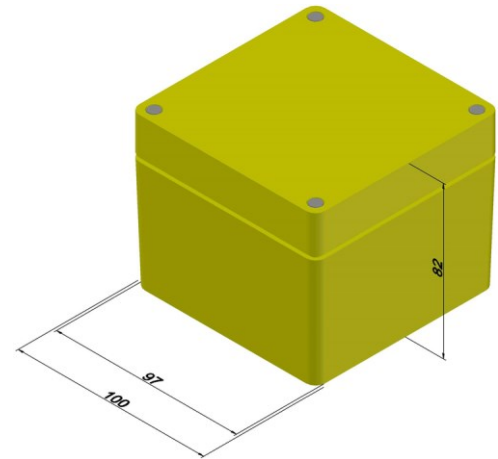

Figure 2. Design and geometry of cuboid (units given in mm)

2.3 Terrestrial laser scanner (TLS)

The Faro Focus laser scanner used by HR Wallingford uses phase shift laser scanning to record the distance between the scanner and objects / surfaces. These scanners are class 3R and operate in the infrared portion of the light spectrum. They are relatively short range, being capable of recording points at distances of up to 120 m.

The scanner uses a touch screen interface to start / stop scans, set scan parameters and enter project

information. Data is recorded to an SD memory card. The scanner can be powered with removable, rechargeable batteries or by a mains adapter.

During operation, a central mirror rotates, reflecting the laser in a vertical plane to determine the pitch. Rotation of the scanner body determines the horizontal angle that the laser is fired at and received from. Using this information, the scanner is able to determine the x, y and z coordinates of each reflected point and to create a full 360° scan of the area (Faro 3D Datasheet).

Two TLS scans were undertaken to provide full coverage of the area of interest. Operation of the TLS is shown in Figure 3.



Figure 3. Operation of the TLS

2.4 Combined laser scanner (CLS)

The 2G Robotics ULS200 is a class 3R combined laser scanner operating in the visible light range, which was tested in air (CLS-IA) and underwater (CLS-UW). The CLS can operate at distances of between 0.21 and 2.5 m, and is capable of 360° rotation in 0.018° increments. During data collection, the scanner records 480 evenly-spaced points per line across a 50° wide swath (ULS200 datasheet), enabling sub-millimetre resolution. The CLS has two modes of operation – point scan mode, in which the scanner is positioned at a fixed location and rotated about its axis (as shown in Figure 4) and profiling mode – in which the scanner is positioned in a fixed orientation about its axis and is physically moved over a target. Both modes were utilised during these investigations.

The resolution across the swath of the collected data (the spacing between points along the laser line) varies with distance from the object of interest. The resolution perpendicular to the swath depends not only upon the range to the target, but also upon the change in rotational angle used to collect data when operating in point scan mode (see below). The change in rotational angle can be set as a number of “steps” varying between 1 and 100 – with 1 being equivalent to rotation of 0.018° between measurements and 100 equivalent to a rotation of 1.8°. During profiling mode the resolution perpendicular to the swath is dependent upon the rate of sampling and the speed at which the unit is driven over the target.

Six scans were undertaken during both the in air and underwater deployment of the CLS. Two profiles were recorded, supplemented with four point scans. The locations of the point scans and tracks of the profiles are shown in Figure 1. Six scans were required to provide full coverage of the area of interest including all faces of the coloured cuboids. The laser scanner was deployed at a height of 0.69 m above the flume floor on a traverser beam capable of moving horizontally in both X and Y axes, enabling quick movement of the scanner around the flume between locations. The position of the scanner was recorded by the traverser control system, enabling the X, Y, Z data collected by the CLS to be re-positioned during post processing according to the scanner’s position in the flume at the time of data acquisition.

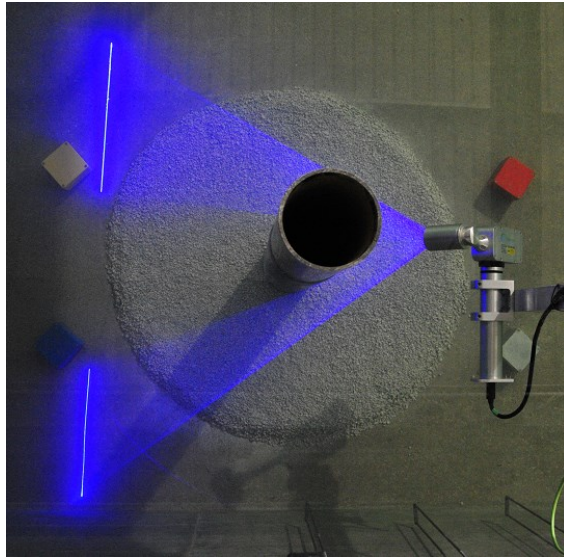

Figure 4. Operation of the CLS-UW

2.5 Structure from Motion (SfM)

The SfM method (Westoby et al., 2012) utilises a number of images of a scene or object taken at different angles and combines them to construct a three-dimensional mesh representation of the scene or object. During the current investigation, 79 photos were taken using a Nikon D90 with an 18-105 mm lens, the positions of which are shown in Figure 5.



Figure 5. Positions of images used in the SfM method

Using the VisualSFM software (VisualSFM, 2015) – an open-source SfM package – images are compared, and common points determined. These common points are used to position the images in space around the object or scene, forming a sparse point cloud. The content of each image is then analysed, resulting in the creation of a dense point cloud. A single colour is then applied to each point, based upon the pixel colours within the images used to generate the dense point cloud, which allows the data to be visualised and analysed. The dense cloud can then be used to generate a mesh model of the scene, allowing more detailed visualisation and analysis. An example mesh model of the scene – generated using the SfM method – is visible in Figure 6.

Although the TLS and CLS both produce X, Y, Z point clouds in which distances are known and the scene can therefore be rendered in three-dimensions, the SfM method produces results with no concept of scale. The relative distances between points in the images are known, but the absolute values of distance are not. Therefore, results

produced using the SfM method must be scaled according to a known distance within the produced mesh. In the present study, distances were scaled based on the known diameter of the monopile.

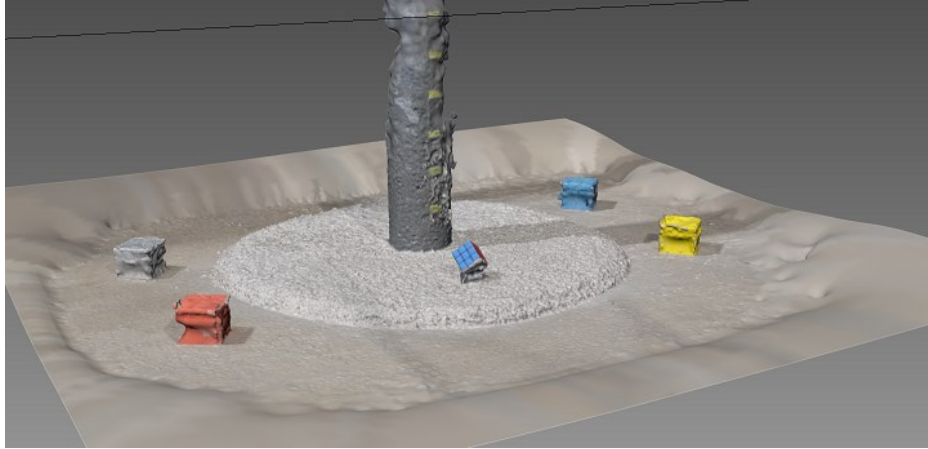

Figure 6. Mesh model generated using SfM method

3. RESULTS

The resultant point clouds from each method were cleaned and imported into Cloud Compare (Cloud Compare Website, 2016) – open-source software that enables analysis of point cloud data – to enable directly comparable results.

Results were cleaned by manually inspecting the data and rejecting erroneous points, typically located around the edges of the cuboids and monopile. When processing TLS and CLS data, a cut-off minimum laser intensity threshold is usually used as a means of more automated and efficient data cleaning when the object(s) of interest vary little in terms of reflectivity and / or colour. However, in the case of the present study, due to the various colours used and therefore wide range of reflectivity experienced from the objects in the flume, rejection based on a minimum laser intensity was not conducted to ensure that potentially valid points received from the objects were not unintentionally rejected. This resulted in a more manual and intensive cleaning process.

With the exception of the computation of volumes and standard deviations, data analysis was undertaken using Cloud Compare. Dimensions of, and distances between, objects were measured manually using the Point Picking tool. In the interest of consistency, care was taken to select points that best represented the spread of data acquired along the edge/surface of the object of interest.

The standard deviation of points in the z axis was calculated using Microsoft Excel on a subset of data extracted from the top face of each cuboid. Volume of the scour protection material was calculated using ESRI ArcGIS software. The cut/fill method was used, in which the difference between two datasets is calculated – one which includes the armour material and one with the armour material removed to leave only the flume floor.

Each method was used to estimate the diameter of the monopile (0.168 m) and rock protection (1.07 m), and the volume of rock protection used. The results of these estimates are shown in Table 1. As the monopile and rock protection diameters are of known size, error values were calculated from the collected data. These are presented as the percentage values given in brackets in Table 1. Note that the SfM method returns a N/A for the diameter of the monopile as this known diameter was used to scale the results of the SfM technique.

Error values for the monopile diameter from the laser scanner methods ranged from -6.0% to +19.6% - both of which were recorded by the TLS. The TLS data showed a variation in the monopile diameter with height above the flume floor, being thinner at the bottom and thicker at the top. In contrast, the CLS provided values very close to the actual monopile diameter for both the in air and underwater modes of operation.

The diameter of the rock protection was approximately 1.07 m, although this value will have varied slightly (on the order of a few mm) around the monopile. The variation seen within the laser-based techniques was small at 1.7% (between 1.06 m for CLS-UW and 1.078 m for CLS-IA). The greatest level of variation was seen in the SfM method, which estimated the diameter of the rock protection at 1.084 m, a difference of +1.3%.

The reported volume of rock protection also varied between methods. The CLS values, both in air and underwater, were largely consistent with each other at 0.028 and 0.027 m³ respectively. Equally, the values reported by the SfM

and TLS methods were consistent at 0.034 m³, but varied from the values reported by both the two CLS methods.

Table 1 – Comparison of methods for determining the monopile diameter and extent and volume of rock protection. Differences between measured and known values are shown in brackets

Parameter	SfM	Terrestrial Laser Scanner	Combined Laser Scanner (IA)	Combined Laser Scanner (UW)
Diameter of Monopile (m)	0.168 (N/A)	0.158-0.201 (-6% to +19.6%)	0.166 (-1.2%)	0.169 (+0.6%)
Diameter of Rock Protection (m)	1.084 (+1.3%)	1.069 (-0.01%)	1.078 (+0.8%)	1.06 (-0.9%)
Volume of Rock Protection (m³)	0.034	0.034	0.028	0.027

The height, width and length of each cuboid was determined using each measurement method. These values were averaged across all four cuboids, with the results presented in Table 2. The errors shown in brackets were calculated as the variation from the known values of height (8.2 cm), width (9.7 cm) and length (9.7 cm) of the cuboids, as shown in Figure 2. The error values were made positive prior to averaging so that the average error reflects the average error magnitude.

Across the size measurements, the SfM method performed the most accurately, with an average error of 1.3% (Table 2), while the CLS-UW also performed well with an average error of 1.6%. The CLS-IA reported a larger average error at 2.9%, while the TLS struggled with the silver cuboid, resulting in an average error of 6.9%. All of the methods except the CLS-UW reported width and length more accurately than height.

Table 2 – Comparison of methods for determining the height, width and length of the cuboids. Differences between measured and exact values are shown in brackets

	SfM	Terrestrial Laser Scanner	Combined Laser Scanner (IA)	Combined Laser Scanner (UW)
Height (cm)	8.4 (2.2%)	9.1 (11.1%)	8.6 (4.5%)	8.2 (0.6%)
Width (cm)	9.7 (0.9%)	9.2 (5.4%)	9.9 (2.0%)	10.0 (2.7%)
Length (cm)	9.8 (0.7%)	9.3 (4.2%)	9.9 (2.2%)	9.8 (1.6%)
Average Error	1.3%	6.9%	2.9%	1.6%

Determination of the best colour to use in physical modelling experiments was a key objective of the present study. Averaging the errors for each individual cuboid colour across the different techniques and the measurements of the cuboid dimensions, the best performing cuboid colour was yellow. The average error for the yellow cuboid was 1.7%, followed by the red cuboid at 1.9% and blue at 2.3% (Table 3). The worst performing colour was silver with an average error of 6.8%. Removing the results of the TLS, which returned poor data from the silver cuboid, results in an average error for the silver cuboid of 5.3% - still the highest value reported by any method.

Table 3 – Average of height, width and length measurement errors by cuboid colour

Cuboid colour	Average error (%)
Red	1.9
Silver	6.8
Yellow	1.7
Blue	2.3

To further demonstrate the differences in response of each method to each cuboid, the Standard Deviations of the points around the top faces of the different coloured cuboids are presented in Table 4. The most accurate data was received from the yellow cube, with the greatest spread of data produced by the silver cube. With the removal of the

inaccurate TLS data, the silver cube average standard deviation drops to 1.1 mm – still higher than both the yellow and blue cuboids.

On a method-by-method basis, the smallest spread of data was recorded by the CLS-UW, with an average standard deviation across all methods of 0.5 mm. The highest average standard deviation was recorded by the TLS (3.5 mm). Removal of the silver cuboid data reduces this to 1.2 mm – in line with that recorded by the SfM and CLS-IA methods.

The density of available data also varies between methods. The least amount of points covering the top of the coloured cuboids was returned by the SfM with one cuboid top covered by only 400 points. The best resolution was achieved by the CLS-UW which achieved a minimum of 13,000 points per cuboid top, which corresponds well with the lowest standard deviation, which was also achieved by the CLS-UW. This was greater than the minimum of 7,000 points achieved by the CLS-IA with identical settings. This variation occurs due to the refraction of the water causing a difference in the swath width between the in air and underwater scans. The spacing between points (along the laser swath) over a cube in water was approximately 1.3 mm, while the spacing between points in air was larger at approximately 2 mm. The TLS provided a minimum of 700 points per cuboid surface.

Table 4 – Standard deviation of the top faces of each cuboid colour, presented for each technique. Units are in mm.

mm	Red	Silver	Yellow	Blue	Average
SfM	1.3	1.3	1.7	1.2	1.4
TLS	2.0	10.4	0.7	1.0	3.5
CLS-IA	1.2	1.4	0.7	1.2	1.1
CLS-UW	0.3	0.5	0.5	0.7	0.5
Average	1.2	3.4	0.9	1.0	

A solved Rubik’s Cube was placed in the flume (Figure 1) and scanned using the three dry methods: SfM, TLS and CLS-IA. Each side of the Rubik’s cube measures 5.7 cm. The cube was deployed on a stand on top of the rock armour protection (thickness 3.1 cm). The combined height of the cube, stand and rock protection was 13.3 cm. The measured width, length and height of the cube above the flume bed shown in Table 5, with error values given in brackets. Note that no values are presented for the CLS-UW as the Rubik’s Cube is positively buoyant and was therefore only scanned using the dry methods.

The lowest average error was reported by the SfM method (2.6%), while the highest error was reported by the TLS (6.9%). The SfM method measured the width and length of cube accurately, but struggled with the z axis, with an error of 4.3% on the measurement of height. In contrast, the TLS was very accurate when reporting the height – with an error of only 0.3% - but underestimated both the width (-12.5%) and length (-7.9%) of the cube. Errors for the CLS-IA were more comparable between height, width and length measurements, with an average of 3.9%.

Table 5 – Comparison of methods for determining the height, width and length of the Rubik’s Cube. Differences between measured and exact values are shown in brackets

	SfM	Terrestrial Laser Scanner	Combined Laser Scanner (Air)
Height to floor (cm)	13.9 (-4.3%)	13.3 (+0.3%)	12.9 (-3.2%)
Width (cm)	5.6 (-1.8%)	5.0 (-12.5%)	5.4 (-6.1%)
Length (cm)	5.6 (-1.8%)	5.3 (-7.9%)	5.6 (-2.3%)
Average Error	2.6%	6.9%	3.9%

To establish the accuracy of the various methods across a larger area, the minimum distances between cuboids were measured from the point clouds produced by each method. The minimum distance between the red and yellow cuboids was 1.21 m, while that between the silver and blue cuboids was slightly higher at 1.23 m. These distances were known based upon measurements made during the experiment set up. Table 6 shows the distances recorded by each method with the percentage error from the known value shown in brackets. All four methods were very accurate in their determination of the distance between cuboids with a maximum error of 0.8%. The CLS-UW was the least accurate method with an average error of 0.8%, with the other 3 methods all reporting average errors of 0.4% having provided a zero error for one of the two distance measurements.

Table 6 – Comparison of methods for determining the minimum distance between cuboids. Differences between measured and exact values are shown in brackets

	SfM	Terrestrial Laser Scanner	Combined Laser Scanner (Air)	Combined Laser Scanner (Water)
Red to Yellow (m)	1.21 (0%)	1.21 (0%)	1.22 (+0.8%)	1.22 (+0.8%)
Silver to Blue (m)	1.24 (+0.8%)	1.24 (+0.8%)	1.23 (0%)	1.24 (+0.8%)
Average Error	0.4%	0.4%	0.4%	0.8%

4. DISCUSSION

The three instruments and four methods of DEM creation investigated share many similarities but also come with individual strengths and weaknesses.

4.1 Ease of operation

The simplest method to set up and execute is the SfM method, which requires only an operator and a standard digital camera. As such, this method can be used in any location and at any time – both within the lab and externally. It is a fast and efficient method of data collection. Additionally, when using the SfM method, operation from multiple angles is a fast process due to the mobility of the camera operator. This technique can therefore be fully completed within a 10 minute period, whereas both the TLS and CLS methods require a minimum of 2 positions to create a three-dimensional DEM of an object or scene.

The TLS is self-contained, requiring only a tripod to enable deployment. The set-up is more complex than that for the SfM method, with more settings to consider, but the touch-screen interface of the TLS makes this a relatively simple task. The requirement to move the tripod between scans and the length of time taken – approximately 10 minutes per scan – means that the TLS requires at least 25 minutes for two scans including set-up and positional changes. A set of two TLS scans therefore occupies a similar duration to two high-intensity CLS scans.

The CLS is not as self-contained as the simple tripod-mounted TLS, requiring additional hardware in the form of a mount or traverser to enable operation and a computer for data logging. This makes operation within large basin areas difficult. The CLS is therefore more suited to deployment in a flume environment where long, narrow transects of data are often required. However, a distinct advantage of the CLS over both the TLS and SfM methods is its ability to operate both in air and underwater, with the underwater operation of particular interest to the physical modelling community. The CLS is the only method with which detailed measurements can be made either in-test or between tests without the requirement to drain the facility, which offers the potential to save large amounts of time and money as filling large physical modelling facilities can be time consuming and, as a result, costly.

Both the TLS and SfM methods are able to return “true colour” images of the object or scene being scanned. The SfM, as it is composed entirely of photographs, and the TLS, as following its laser scan it takes a series of photographs, allowing red-green-blue colour values to be associated to each data point. This is not possible using the CLS and may under certain circumstances provide an advantage.

4.2 Cost

The SfM method can be executed using any digital camera. A good camera will cost in excess of £300, however, all of the SfM software is freely available (Cloud Compare, VisualSFM).

A full TLS or CLS system will cost in excess of 80 times the cost of a digital camera, with the CLS, as noted in Section 4.1, also requiring an additional mount or traverser system to facilitate deployment.

4.3 Data analysis

The CLS-UW provided the best estimates of the monopile and rock protection diameters in Table 1, being within 1% of the known values for both parameters. The performance of the TLS method was much more variable, with measurement of the diameter of the monopile a cause for concern as the TLS indicated that the monopile was thinner at the bottom and thicker at the top than the known OD of the pipe. It is worth highlighting that as the TLS is scheduled to undergo a routine calibration soon, the variable performance of this method may have been due to instrument drift. However, it could instead be due to the TLS system struggling with the rounded surface or colour of the monopile. Interestingly, there was no consistency in the over / under prediction between the CLS-IA and CLS-UW scans, with

the diameter of the monopile being under predicted in air and over predicted in water, while, in contrast, the diameter of the rock protection was over predicted in air and under predicted in water. The difference in the estimated volume of the rock protection between the two CLS methods which predicted 0.027 and 0.028 m³ respectively, and those for the SfM and TLS methods, which both predicted 0.034 m³ may be due to the resolution of the different methods. The SfM and TLS methods produced point clouds that were an order of magnitude less dense than those produced by the CLS methods. The minimum number of points making up the tops of the coloured cuboids were 400 and 700 points respectively for the SfM and TLS methods – far lower than the 7,000 and 13,000 recorded by the CLS-IA and CLS-UW methods. This lack of resolution may have resulted in some of the more detailed aspects of the rock protection structure being missed and therefore the volume of the rock protection being overestimated by the SfM and TLS methods.

Overall, the methods were all good at determining objects of a large size accurately. The monopile width, diameter of rock protection (Table 1) and distances between cubes (Table 6) were all estimated well, despite the problems that the TLS encountered with the silver cuboid. Greater errors occurred when determining the dimensions of small objects such as the coloured cuboids and the Rubik’s Cube.

When measuring the dimensions of the coloured cuboids, SfM was the best performing method with an average error of 1.3%, despite the low resolution of data collected by the SfM method. However, the average standard deviation across all of the cuboid colours recorded using the SfM method was 1.4 mm (Table 4) – almost three times that of the CLS-UW which, with an average error of 1.6%, was the second best performing method in regard to the coloured cuboid dimensions (Table 2). Both of these methods outperformed the TLS method which had an average error of 6.9% for the cuboid dimensions and an average standard deviation of 3.5 mm across all of the cuboid colours. It is worth noting that the CLS-IA was the only method to consistently underestimate the cuboid dimensions. In contrast, the TLS method overestimated in the z axis (height), but tended to underestimate both width and length (x, y axes). The SfM method and CLS-UW tended to overestimate width and length but were both accurate in determining height.

Although it performed well in many of the benchmark tests, the SfM method required extensive processing to get the data into a high-quality state. The resultant mesh, visible in Figure 6, still shows evidence of poor data around the monopile and the coloured cuboids. This is in contrast to a point cloud generated using the CLS-UW, shown in Figure 7, which shows that the objects of interest are more clearly defined. Whilst this is the case, the figure shows that complete coverage of all four vertical cuboid faces was not achieved. This was due to the orientation of the scanner relative to the cuboids – specifically the angle that the incident light made with each vertical face. The face with limited data coverage was one of the “outer” faces (relative to the CLS scan positions – see Figure 1). In the case of the “inner” cuboid faces, the angle that the incident light made with the object surface was much closer to the normal than was the case with the “outer” faces.

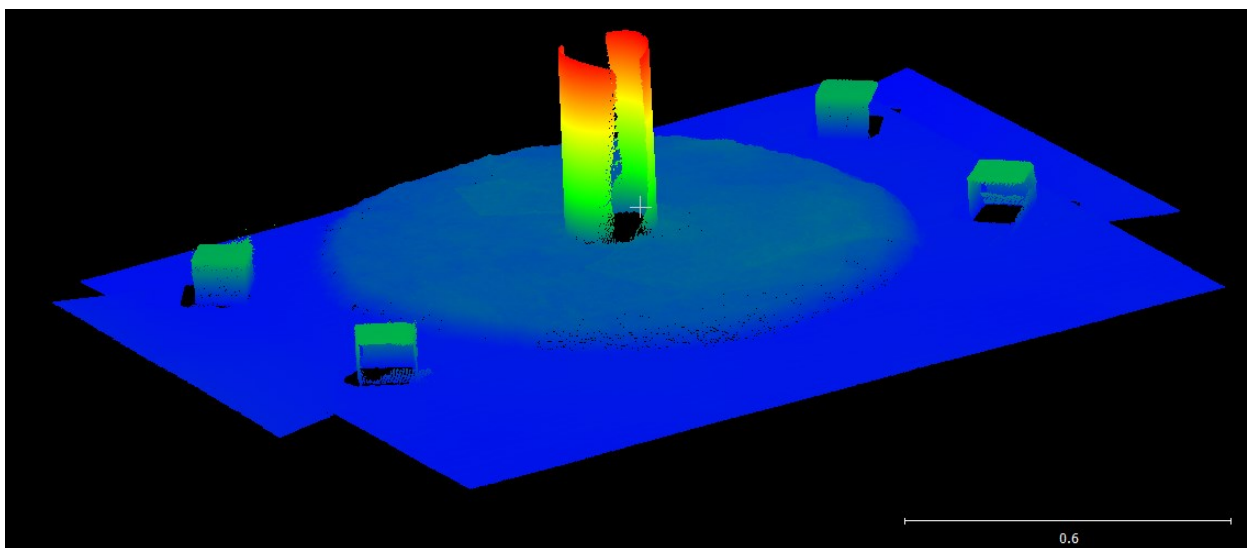

Figure 7. Mesh model generated using CLS-UW method (scale in m)

In regard to the best colour to select for the creation of DEMs from physical modelling results, Table 4 indicates that yellow should be the colour of choice, closely followed by blue and red. Silver, and reflective surfaces in general, should be avoided. The TLS in particular struggled with the silver cuboid. This was likely due to the reflective surface of the silver cuboid causing under-saturation of the TLS receiving sensor. The TLS, as with the other laser techniques, works through light being reflected back to the receiving sensor. A diffuse surface – one that is non-reflective – will

reflect light in all directions, and therefore light will be reflected back to the receiving sensor. Surfaces that are highly reflective, such as the silver cuboid, are more difficult to scan as very little of the light that is emitted from the scanner is reflected back to the receiving sensor, resulting in a strong under-saturation. For the points used in calculating the standard deviations of points returned from the top of the coloured cuboids (Table 4), the average intensity return from the silver cuboid was 81 (scale 0-255), just 64% of that returned from the next lowest cuboid, blue at 127, and less than half of that returned from the yellow cuboid (179).

The error values recorded for the Rubik's Cube were, on average, higher than those reported for the coloured cuboids. This may be due to the contrasting colours both within a single face (made of multiple coloured squares with black outlines) and between faces, as the sharp colour change may have been more difficult for the instruments to process. The instruments had a tendency to underestimate the dimensions of the Rubik's Cube, with all recorded measurements except for the height of the cube, as measured by the TLS, being underestimated (Table 5).

5. CONCLUSIONS

A number of methods are available for creating DEMs of physical hydraulic models. Three of them: a terrestrial laser scanner, combined laser scanner and structure from motion, have been applied to the measurements of scour protection around a monopile foundation:

- The combined laser scanner in underwater mode (CLS-UW) gave low errors and is deployed without having to drain the facility. It requires a traverser system to move it to known locations and software had to be written to combine the traverser and CLS output data. However, once this was complete it is easy to operate. The instrument has a short range (up to 2.5 m) so is limited by the traverser extent and speed. An area of about 7 m by 4 m can be measured in half an hour;
- The terrestrial laser scanner is relatively quick and intuitive to use, requires only the scanner, a tripod and some targets (used to help patch together different scans) to operate it, but operates only in air. Although a combined air-water laser system has recently been developed (Atkinson and Baldock, 2016) this is not available for scanning areas. Errors were slightly larger than for the CLS-UW. The TLS used had a range of over 100m, more than enough for the vast majority of laboratory users. One scan takes approximately 10 minutes, so this is a faster technique than the CLS-UW or IA for application to large basins.
- SfM is the cheapest technique to implement and the quickest to obtain data (if access round the model is safe and easily accomplished) but struggles to create a full shape and more care must be taken with the processing than for the commercial laser scanners. It does not pick up evenly-coloured surfaces (such as monopiles) unless there are distinguishing features that can be picked up in successive photographs.

The Fast Flow Facility requires up to 1,000 m³ of water to fill. The ability to create a detailed, accurate digital elevation model covering a few metres squared around an offshore foundation without having to drain and fill the facility is a considerable advantage over point-based methods or those that require the facility to be drained. The CLS-UW is therefore the preferred choice of scanner for applications, such as scour studies, that cover a few square metres.

ACKNOWLEDGEMENTS

This project was funded by HR Wallingford Company Research funds.

REFERENCES

- Atkinson and Baldock, 2016. A high-resolution sub-aerial and sub-aqueous laser based laboratory beach profile measurement system. *Coastal Engineering* 107: 28 – 33.
- CIRIA/CUR/CETMEF, 2007. The rock manual. The use of rock in hydraulic engineering (2nd Edition). C683, CIRIA, London.
- Cloud Compare, 2016. Cloud Compare Website, <http://www.danielgm.net/cc/>
- Faro 3D datasheet, 2015. Faro website, <http://www.faro.com/products/3d-surveying/laser-scanner-faro-focus-3d/downloads>
- Porter, Simons and Harris, 2014. Comparison of three techniques for scour depth measurement: photogrammetry, echosounder profiling and a calibrated pile, Proceedings of 34th Conference on Coastal Engineering, Seoul, Korea. https://icce-ojs-tamu.tdl.org/icce/index.php/icce/article/view/7675/pdf_858
- ULS200 datasheet, 2015. 2G Robotics website, <http://www.2grobotics.com/products/underwater-laser-scanner-uls-200/>
- Westoby, M.J; J. Brasington, N.F. Glasser, M.J. Hambrey, J.M. Reynolds, 'Structure-from-Motion' photogrammetry: A low-cost, effective tool for geoscience applications, *Geomorphology*, Volume 179, 15 December 2012, Pages 300-314, ISSN 0169-555X, 10.1016/j.geomorph.2012.08.021
- VisualSFM, 2015. VisualSFM Website, <http://ccwu.me/vsfm/>