

Fibre-optic sensor for monitoring splanchnic perfusion

M. Hickey and P.A. Kyriacou

School of Engineering and Mathematical Sciences, City University
Northampton Square, London, EC1V 0HB, United Kingdom
m.hickey@city.ac.uk p.kyriacou@city.ac.uk

ABSTRACT

There is a need for reliable monitoring of abdominal organ oxygen saturation (SpO_2). Preliminary pilot studies using an electro-optical sensor have shown that good quality photoplethysmographic (PPG) signals can be detected from various human abdominal organs during open labarotomy. In an attempt to develop a splanchnic perfusion sensor that can be used pre-operatively, operatively and post-operatively, a new fibre optic sensor and processing system utilising the principle of reflectance pulse oximetry has been developed. To determine the optimal configuration (source/detector separation) of the optical fibres, an experimental procedure was carried out to examine the effect of separation distance on the acquired PPG signals, and to ultimately select a source-detector separation distance for the final design of the fibre-optic probe. PPG signals were obtained from the finger for all separation distances. The optimum range for source-detector separation was found to be between 3mm and 6mm. At closer separation, PPG signals were too erratic and unstable, while at larger separation the amplitudes of PPG signals were very small. The development of the fibre-optic probe as well as the experimental set-up and the results of the investigations are presented.

KEY WORDS

Splanchnic perfusion, reflectance pulse oximetry, reflectance, photoplethysmography

1. Introduction

Ischaemia of the gut may occur intra-operatively or in critically ill patients with low flow states of cardiogenic or hypovolaemic origin [1]. When an organ or tissue suffers severe hypoperfusion or extreme hypoxia, organ dysfunction follows. Tissue hypoxia of one organ may lead indirectly to dysfunction or failure of distant organs through the release of mediators and various toxins [2]. In the case of bowel ischaemia, the loss of mucosal barrier function results in bacterial translocation and endotoxin absorption into portal blood which can amplify the systemic inflammatory response following surgery [3, 4]. This may contribute to the development of multiple organ failure which remains a common cause of death and morbidity following major surgery despite advances in intensive care management. Previous studies have led to the speculation that the gastrointestinal tract might be the

canary of the body, making early detection of inadequate tissue oxygenation feasible [5]. Therefore, it is of utmost importance to monitor splanchnic perfusion.

Currently there is no widely accepted and readily available monitoring technique to measure splanchnic perfusion and, most importantly, to quantitatively measure splanchnic oxygen saturation. Techniques used to assess splanchnic perfusion such as polarographic oxygen electrodes, luminescent oxygen probes, magnetic resonance spectroscopy and positron emission tomography remain research tools [2]. Manual fluid tonometry which is currently considered as the only clinically available tool for assessing splanchnic perfusion is still not routinely used, as it is found to be intermittent, operator dependent and time consuming [6, 7]. Methods such as laser Doppler, Doppler ultrasound, and intravenous fluorescein have been previously explored to assess intestinal ischaemia in animals [8-11]. Many of these techniques are complex and expensive and none of them directly measures oxygenation. Therefore, there is a need for a simple, reliable, and continuous method for estimating abdominal organ blood oxygen saturation (SpO_2). Animal studies have also shown that pulse oximetry could be used to monitor intestinal oxygen saturation [11]. However, there are difficulties in applying conventional pulse oximeters directly in the viscera as such probes are bulky and not custom designed for such anatomical areas and also not easily sterilizable. Moreover, none of the currently available probes could be left in the abdomen for prolonged postoperative monitoring. Preliminary pilot studies using a custom made reflectance electro-optical sensor have shown that good quality photoplethysmographic (PPG) signals can be detected from various human abdominal organs (bowel, kidney, liver) during open labarotomy [1]. This indicates the feasibility of pulse oximetry for the measurement of splanchnic blood oxygenations in humans.

As a preliminary to constructing a suitable pulse oximeter for assessing splanchnic perfusion this paper describes the development and technical evaluation of a new fibre-optic sensor and processing system.

2. Background

Pulse oximeters estimate arterial blood oxygen saturation by shining light at two different wavelengths, red and infrared, through vascular tissue. In this method, the ac pulsatile PPG signal associated with cardiac contraction is

assumed to be attributable solely to the arterial blood component. The amplitudes of the red and infrared ac PPG signals are sensitive to changes in arterial oxygen saturation because of differences in the light absorption of oxygenated and deoxygenated haemoglobin at these two wavelengths. From the ratios of these amplitudes, and the corresponding dc photoplethysmographic components, arterial blood oxygen saturation (SpO_2) is estimated. Hence, the technique of pulse oximetry relies on the presence of adequate peripheral arterial pulsations, which are detected as photoplethysmographic signals [12].

3. Methods

A new reflectance photometric sensor comprising of three optical fibres coupled to infrared and red subminiature version A (SMA) mounted emitters and a photodiode has been developed. A PPG processing system was also developed to detect and pre-process the red and infrared ac and dc PPG output signals. These signals were then digitised by a 16-bit data acquisition card (National Instruments, DAQPad-6015). The digitised PPG signals were further filtered, analysed, and displayed by a *Virtual Instrument (VI)* implemented in *LabVIEW*.

3.1 Fibre Optic Probe

Silica glass step index multimode fibres were chosen with a core of $600\mu\text{m}$ for the transmission and reception of light to the tissue. The fibres were protected with a hard polymer buffer, Kevlar strands, and an outer Tefzel jacket. Bare fibre was exposed at one end of each fibre cable. The fibre was cleaved to achieve a flat surface at 90 degrees to the emitting light. The tip of each fibre was polished with a $5\mu\text{m}$, $3\mu\text{m}$, $1\mu\text{m}$, and $0.3\mu\text{m}$ polishing film to ensure that:

- There was only light random scratches, and the fibre region is free of large scratches
- There were no chips in the edges of the fibre that extended into the core of the fibre
- There are no more than two chips in the edges of the fibre, such that the length plus the width of the chips does not exceed 20% of the circumference of the fibre.

The opposite end of each fibre was attached to an SMA connector, for coupling with SMA mounted LEDs. Three fibre cables were used; two to transmit the red and infrared light to the tissue, and another to receive the backscattered light.

SMA mounted red and infrared LEDs with peak emission wavelengths at 650 nm and 850 nm respectively were used. A single photo-diode with an active area of 1mm^2 was used to detect the backscattered light from the tissue.

3.2 PPG Processing System and Acquisition System

An acquisition and processing system, has been developed to detect, process, record and display the red and infrared ac and dc PPG signals. A block diagram of

the processing system is shown in Figure 1. The emitters, red (R) and infrared (IR), are driven by software controlled constant current sources. Output signals generated in the *Virtual Instrument (VI)* drove the current sources via the outputs ports of a 16-bit analogue-to-digital card (ADC) (National Instruments DAQPad-6015). The red and infrared emitters were turned on and off at 500 Hz. The photodetector detects the energy backscattered by the tissue and gives an output current proportional to the detected light intensity. The output of the current-to-voltage (I-V) differential amplifier contains multiplexed PPG signals corresponding to red and infrared wavelengths. The signal from the current-to-voltage differential amplifier passes to a demultiplexer synchronised to the output clock signals from the DAQCard, which separate the red (R) and infrared (IR) signals. The two signals (R and IR) are then filtered to extract the ac and dc PPG components for each wavelength. The output PPG signals are digitised using the DAQCard and further analysed by the *Virtual Instrument*. PPG traces corresponding to infrared and red wavelengths are obtained simultaneously and displayed on the personal computer screen. All acquired signals are also saved in spreadsheet format for further post processing analysis.

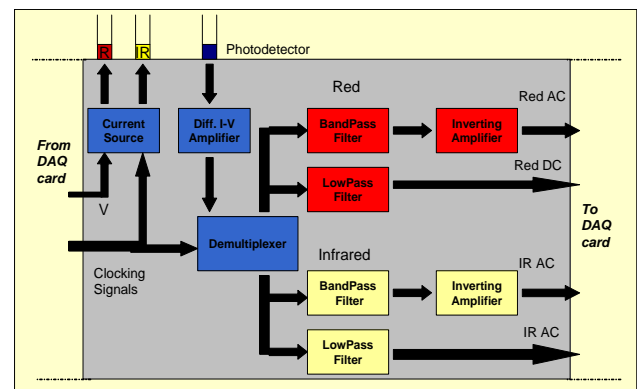

Figure 1: Block Diagram illustrating the various stages of the PPG Processing system

3.3 Optimal Source-Detector Separation Study

The separation between the emitters and the photodetector is of great importance and significance in designing a reflectance pulse oximeter probe as it bears a direct impact on the quality of the PPG signal and the accurate estimation of SpO_2 . Therefore, it was of great significance to investigate in detail and establish the optimum separation distance between the light emitting fibres and the light receiving fibre prior to the finalisation and manufacturing of the probe. Such an investigation will allow us to observe the amplitude and morphology of ac and dc PPG traces at both wavelengths and various separation distances.

In order to conduct this experiment, a precision drilled perspex finger piece was designed to allow for the placement of fibres at various distances (Figure 2). All

separation distances given are from the centre of the emitting fibre to the centre of the detecting fibre. During the experiment, PPG signals obtained from the finger at both wavelengths were recorded simultaneously while varying the separation between emitter and detector at 1mm increments (range: 1-8 mm). During the experiment the emitter current was maintained constant at 40 mA. Any overhead fluorescent lights were switched off to minimise artefacts.

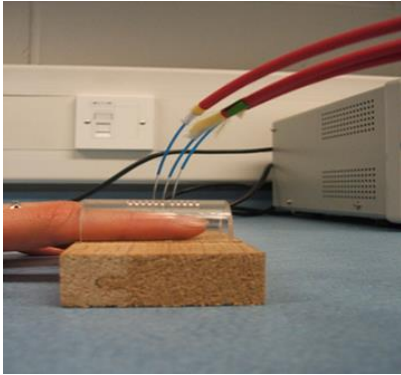

Figure 2: Illustrating the use of a precision drilled perspex piece for the placement of fibres during the separation experiment

4. Results

Photoplethysmographic signals of good quality were recorded at both wavelengths at all separation distances between the transmitting and receiving fibres. Figure 3 depicts typical finger ac PPG traces obtained at various separation distances.

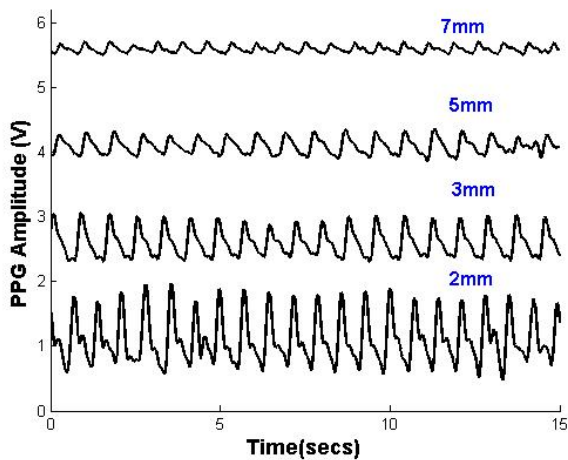

Figure 3: Typical photoplethysmographic (PPG) traces from the finger at various fibre separation distances

Although PPG signals were obtained at almost all separation distances, there were significant differences in signal amplitude, and morphology at the various monitoring separations. Very large amplitude PPG signals were acquired at 1 mm separation. However, these signals were of very poor quality. Their morphology was not of the usually expected PPG plus they were very noisy and erratic. Signals within the range of 2 mm to 6 mm produced ac PPGs of good quality with large amplitudes

and high signal-to-noise ratio (SNR). Over 6mm separation distance the resulted ac PPGs were of poor quality and very low amplitude (figure 3).

R and IR PPG Amplitude at 40mA Drive Current

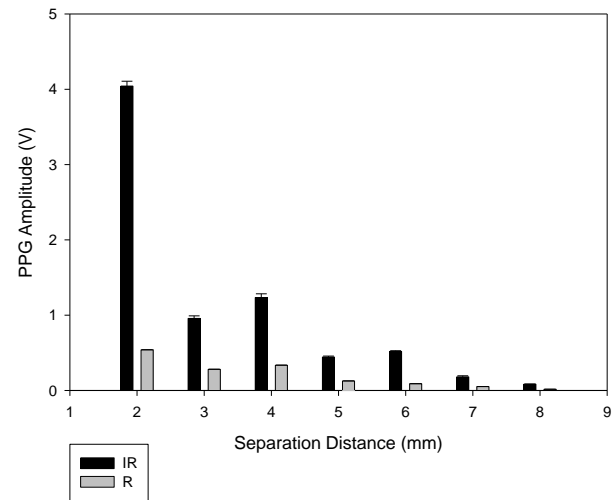

Figure 4: Mean PPG, red (R) and infrared (IR), ac amplitudes and Standard Deviation at all investigating separation distances (drive current at 40mA)

R and IR DC Amplitude at 40mA Drive Current

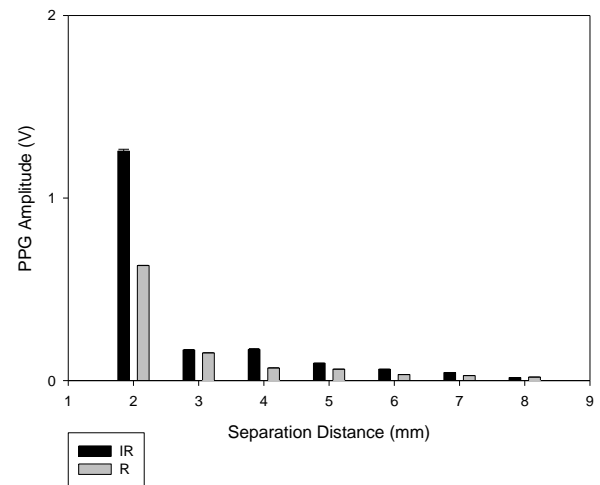

Figure 5: Mean PPG, red (R) and infrared (IR), dc amplitudes and Standard Deviation at all investigating separation distances (drive current at 40mA)

Figure 4 shows the mean ac red and infrared PPG amplitudes (Standard Deviation) for all separation distances. It can be clearly seen that the PPG amplitudes decrease as the separation distance is increased. Such a phenomenon is well explained as the transfer of photons to the emitter via the tissue bed decreases as the distance between the emitting source and the receiving source increases. Figure 5 shows the mean dc red and infrared PPG signals (Standard Deviation) for all separation distances. The dc signal at 2mm separation was

predominately larger than at other separation distances. This suggests that the source and detecting fibres are too close, and therefore saturating the photodetector.

5. Conclusion

The development of a real-time blood oxygen saturation monitoring system for the splanchnic area would greatly aid in the timely assessment of the patient medical condition. Quick detection of changes in tissue oxygenation in the viscera could allow for earlier intervention to restore splanchnic blood flow, and improve survival in critically ill patients.

A fibre-optic based pulse oximeter system has been successfully designed and developed. Detailed experiments to determine the optimum separation distance between the receiving and the transmitting fibres of the probe have been conducted in the laboratory.

Photoplethysmographic signals acquired at 1 mm distance between the transmitting and receiving fibres are found to be unsuitable as the resulted PPG signals, both ac and dc, were noisy, erratic, and of extremely large amplitudes. This is possibly due to saturation of the photodetector. Also, such separation distance will ultimately result in the erroneous estimation of blood oxygen saturation. At 2 mm separation the ac PPG signal was of better quality than the 1 mm separation. However, the dc level produced at this separation was clearly unsuitable for estimation of SpO₂ as they caused the photodetector to saturate again. Both ac and dc PPG signals in the range of separation between 3 and 6 mm were of good quality with large ac amplitudes and dc values within the expected range. Such signals will be most suited for the accurate estimation of blood oxygen saturation. PPG signals above 6 mm separation produced weak signals of low amplitude and very poor signal to noise ratio. Such signals will be unreliable in the estimation of blood oxygen saturation and, therefore, such distances between transmitting and receiving fibres should be avoided.

In conclusion this work has demonstrated that the optimum separation distance between the emitting optical fibre and the receiving fibre in the development of a fibre-optic probe for splanchnic perfusion should be within the range of 3 to 6 mm. These results, although preliminary, suggest that it might be feasible to develop a fibre-optic pulse oximeter that will be used for the estimation of splanchnic blood oxygen saturation pre-operatively, operatively and post-operatively. Further studies will be conducted to verify the use and ability of this probe in a clinical setting.

Acknowledgements

This work has been sponsored in full by the Engineering and Physical Sciences Research Council (EPSRC).

References

- [1] A.J. Crerar-Gilbert, P.A. Kyriacou, D.P. Jones & R.M. Langford, Assessment of photoplethysmographic signals for the determination of splanchnic oxygen saturation in humans, *Anaesthesia*, 57, 2002, 442-445.
- [2] Jury of the Consensus, Tissue Hypoxia: How to detect, how to correct, how to prevent?, *Intensive Care Med*, 22, 1996, 1250-1257
- [3] D. Rittoo, P. Gosling, C. Bonnici et al, Splanchnic oxygenation in patients undergoing abdominal aortic aneurysm repair and volume expansion with eloHAES, *Cardiovascular Surgery*, 10, 2002, 128-133
- [4] T. Koch, S. Geiger, M.J.R. Ragaller, Monitoring of Organ Dysfunction in Sepsis/Systemic Inflammatory Response Syndrome: Novel Strategies, *J AM Soc Nephrol*, 12, 2001, S53-S59
- [5] D.R. Dantzker, The gastrointestinal tract. The canary of the body?, *JAMA*, 270(10), 1993, 1247-8.
- [6] Kolkman JJ, Otte JA, & Groeneveld AB, Gastrointestinal luminal PCO₂ tonometry: an update on physiology, methodology and clinical applications, *British Journal of Anaesthesia*, 84(1), 2000, 74-86.
- [7] Haterhill M, Tibby SM, Evan R, & Murdoch IA, Gastric tonometry in septic shock, *Archives of Disease in Childhood*, 78, 1998 155-158.
- [8] J.J. Ferrara, D.L. Dyess, M. Lasecki, S. Kinsey, C. Donnell, G. Jurkovich, Surface Oximetry. A new method to evaluate intestinal perfusion, *The American Surgeon*, 54, 1988, 10-4.
- [9] Lynn Dyess D, Bruner BW, Donnell CA, Ferrara JJ, & Powell RW, Intraoperative Evaluation of Intestinal Ischemia: A Comparison of Methods, *Southern Medical Journal*, 84(8), 1991, 966-970.
- [10] J. DeNobile, P. Guzzetta, K. Patterson, Pulse Oximetry as a means of assessing bowel viability, *Journal of Surgical Research*, 48, 1990, 21-3.
- [11] P. H. MacDonald, P.K. Dinda, I.T. Beck, C.D. Mercer, The use of oximetry in determining intestinal blood flow, *Surg. Gynecol. Obstet.*, 176, 1993, 451-458
- [12] J.G. Webster, Design of Pulse Oximeters, (Bristol, UK: Institute of Physics Publishing, 2003)