

Miah, S., Kaparias, I. & Liatsis, P. (2015). Development and testing of a prototype instrumented bicycle model for the prevention of cyclist accidents. Paper presented at the 47th Annual Conference of the Universities' Transport Study Group, 05-01-2015 - 07-01-2015, City University London, UK.



**CITY UNIVERSITY  
LONDON**

[City Research Online](#)

**Original citation:** Miah, S., Kaparias, I. & Liatsis, P. (2015). Development and testing of a prototype instrumented bicycle model for the prevention of cyclist accidents. Paper presented at the 47th Annual Conference of the Universities' Transport Study Group, 05-01-2015 - 07-01-2015, City University London, UK.

**Permanent City Research Online URL:** <http://openaccess.city.ac.uk/6246/>

### **Copyright & reuse**

City University London has developed City Research Online so that its users may access the research outputs of City University London's staff. Copyright © and Moral Rights for this paper are retained by the individual author(s) and/ or other copyright holders. All material in City Research Online is checked for eligibility for copyright before being made available in the live archive. URLs from City Research Online may be freely distributed and linked to from other web pages.

### **Versions of research**

The version in City Research Online may differ from the final published version. Users are advised to check the Permanent City Research Online URL above for the status of the paper.

### **Enquiries**

If you have any enquiries about any aspect of City Research Online, or if you wish to make contact with the author(s) of this paper, please email the team at [publications@city.ac.uk](mailto:publications@city.ac.uk).

---

## Cyclist 360° Alert: Development and testing of a prototype instrumented bicycle model for the prevention of cyclist accidents

### Shahjahan Miah

PhD candidate, City University London

### Ioannis Kaparias

Lecturer in Transport Engineering, City University London

### Panos Liatsis

Professor of Image Processing, City University London

### Abstract

Cycling is an increasingly popular mode of travel in cities owing to the great advantages that it offers in terms of space consumption, health and environmental sustainability, and is therefore favoured and promoted by many city authorities worldwide. However, cycling is also perceived as relatively unsafe, and therefore it has yet to be adopted as a viable alternative to the private car. Rising accident numbers, unfortunately, confirm this perception as reality, with a particular source of hazard (and a significant proportion of collisions) appearing to originate from the interaction of cyclists with Heavy Vehicles (HVs). This paper introduces Cyclist 360° Alert, a novel technological solution aimed at tackling this problem and ultimately improving the safety of cyclists and promoting it to non-riders. Following a thorough review of the trends of cyclist collisions, which sets the motivation of the research, the paper goes on to present the Cyclist 360° Alert system architecture design, and examines possible technologies and techniques that can be employed in the accurate positioning of cyclists and vehicles. It then focuses in particular on the aspect of bicycle tracking, and proposes a localisation approach based on micro-electromechanical systems (MEMS) sensor configurations. Initial experimental results from a set of controlled experiments using a purpose-developed prototype bicycle simulator model, are reported, and conclusions on the applicability of specific sensor configurations are drawn, both in terms of sensor accuracy and reliability in taking sample measurements of motion.

### 1. Introduction

Cycling is an increasingly popular mode of travel in cities due to the great advantages that it offers in terms of space consumption, health and environmental sustainability, and is therefore favoured and promoted by many city authorities worldwide. The large number of recently introduced schemes in many cities (such as the Barclays Cycle Hire scheme and the Cycle Super-Highway in London (TfL, 2010) (TfL, 2008)) demonstrates this trend. The European Cyclists' Federation (ECF) is working on tripling cycling in Europe by 2020 (Kuster, et al., 2010). However, the relatively low perceived safety of cyclists from the users' side currently presents itself as a major hurdle to the desired uptake of cycling as a viable alternative to the private car, with a particular source of hazard appearing to originate from the interaction of cyclists with Heavy Vehicles (HVs), i.e. buses, coaches, and Heavy Goods Vehicles (HGVs). Accident numbers, unfortunately, confirm this perception as reality: as reported in the Times, in 2012 there were 122 cyclist fatalities in the whole of Britain, almost a quarter of which (30) involved HVs (The Times, 2013) Related research analysing trends from previous years suggests that this figure is even higher in urban environments, namely of the order of 43% in the example of London (Morgan, et al., 2010).

Motivated by the poor safety record, this paper presents the development of an innovative low-cost technological solution to tackle the cyclist-HV collisions problem, called Cyclist 360° Alert. This relies on bicycles being instrumented with low-cost Micro-electromechanical systems (MEMS) sensors, which take sample measurements of motion based on steering angle, tilt angle and speed, so as to enable real-time tracking. This information will then be processed using intelligent software and communicated over a Wi-Fi link to the HV driver as a warning

through a display unit, such as a smartphone or a tablet, which provides an aerial view of their vehicle.

The paper is organised as follows: Section 2 reviews cyclist collisions and analyses their trends, thus establishing the necessity and importance of this project. In Section 3 the main conditions and occurrence of accidents are identified, and the novel Cyclist 360° Alert concept is introduced. In Section 4, some of the possible localisation technologies and corresponding techniques are reviewed and evaluated as to their suitability, while in Section 5, the overall Cyclist 360° Alert system architecture is presented. In Section 6, the simulator model is illustrated, and the experimental results of the various MEMS sensor configurations tested and reported. Section 7 concludes the paper with a summary and discussion, and outlines the next steps of the research.

**2. Background**

In Britain, every year approximately 19,000 cyclists are killed or injured in road accidents, including around 3,000 who are killed or seriously injured (RoSPA, 2013). The Department for Transport (DfT) has recently released the quarterly provisional estimate of Q3 of 2013, which provides estimates of personal injury road accidents and casualties. The release covers the year ending September 2013, and includes accidents on public roads in Great Britain, which became known to the police within 30 days. The graph in Figure 1 provides a comparison of reported killed or seriously injured road casualties by road user type for each year from 2004 to 2013. The road user type includes car, pedestrian, cyclist and motorcyclist. The graph clearly indicates a rise of cyclists’ casualties in recent years while the trends for other road users are declining. In contrast, Figure 2 compares pedal cycle casualties by severity with the cyclist traffic in Great Britain between 2000 and 2012. It is also clearly shown that the number of seriously injured cyclists has dramatically increased in relation to the increase in pedal cycle traffic.

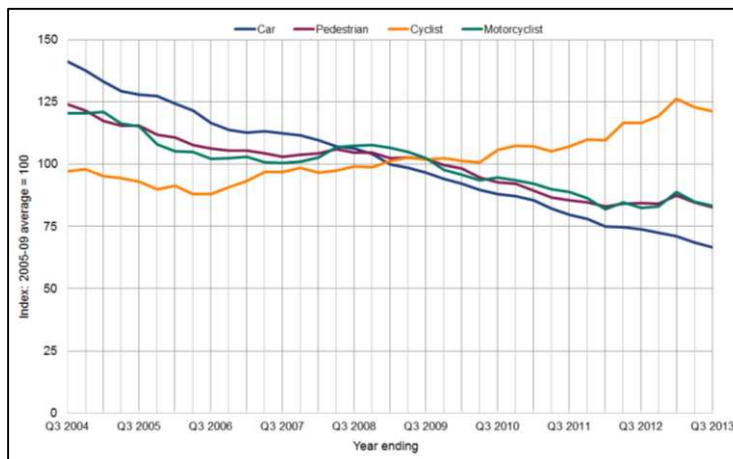

Figure 1: Reported killed or seriously injured (KSI) road casualties by road user type (DfT, 2014)

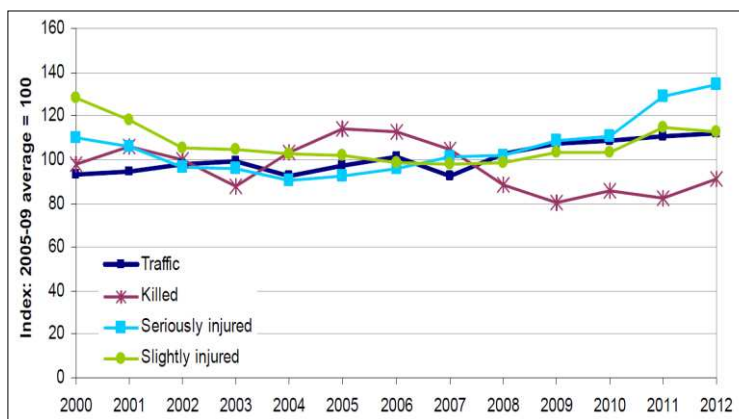

Figure 2: Pedal Cycle Traffic and Reported Casualties by Severity in Great Britain (DfT, 2012)

As can be seen, cyclist casualties are a serious and growing problem, especially when many authorities are promoting cycling through a number of related schemes. As a result, many cycling proponents, such as the European Cyclists' Federation (ECF), ask for measures to be implemented in order to reduce injury and fatality rates for cyclists (Kuster, et al., 2010), and many stakeholders are keen on finding solutions that can achieve that, and thus help promoting cycling.

A number of factors are associated with a collision but one issue that is common with bicycle-related accidents is the blind spot areas around large vehicles. Blind spots are regions of the road that the driver is not able to see by looking directly or through a mirror. Blind spots are also created by the chassis of the vehicle, and especially the windscreen pillars and the area under the windscreen, because of the driver's higher seat position. Typical regions of blind spots surrounding a lorry are illustrated in Figure 3 (a), where the pink-shaded regions on the figure are the blind spots. For example, the four cyclists in the figure are completely obscured by the blind spots, and so the driver would not see them from their normal driving position, as only the green-shaded areas are visible to the driver. In particular the left-hand side blind spot is most hazardous to the cyclists, because the driver sits on the opposite side and is unable to observe the blind spot area by look down the window directly. Furthermore, the side mirrors of an articulated lorry become even less beneficial when it is partially turned, such as at an intersection where the lorry needs to turn left. This where the most common type of fatal collisions for cyclists could take place.

Moreover, despite measures to improve the HV driver's field of vision, there is still an area around the vehicle that the driver is unable to see through the windows or with the help of mirrors and cameras. In addition, the mirrors may not always be adjusted properly, which unnecessarily increases the area not visible to the driver. Above all a HV driver has to contend with a heavy mental burden when they want to turn: the driver must keep an eye on all the traffic at the junction by looking through the windows and in all mirrors. However, not all of the mirrors are in the same direction of view and the eyes take time to change between the mirrors and this may give rise to a situation where a cyclist is overlooked (SWOV, 2012). Although the common perception is that the cyclist-HV related accidents can be solved by utilising more mirrors, this observation is not reflect in the accidents statistics (Schoon, 2006)

### 3. Proposed Approach

The solution to the problem of cyclist-HV collisions proposed in this study is to give HV drivers an aerial view of their vehicle so that they are able to observe the blind-spot regions, hence to detect cyclists in their vicinity. The system is called Cyclist 360° Alert, and its concept of operation is illustrated in Figure 3 (b). As it can be seen, the idea is to enable 360° viewing for HV drivers through an in-vehicle or potable display unit, such as a smart-phone, allowing them to perceive potential hazards earlier, hence be prepared to stop, if necessary, in order to prevent a collision. The system should be able to function in all conditions and environmental settings, as it needs to reply on non-line-of-sight technology. It is also to be integrated with additional features, such as trajectory or path modelling and non-visual interfaces (e.g. auditory and haptic feedback), so as to facilitate more effective warnings to both HV drivers and cyclists.

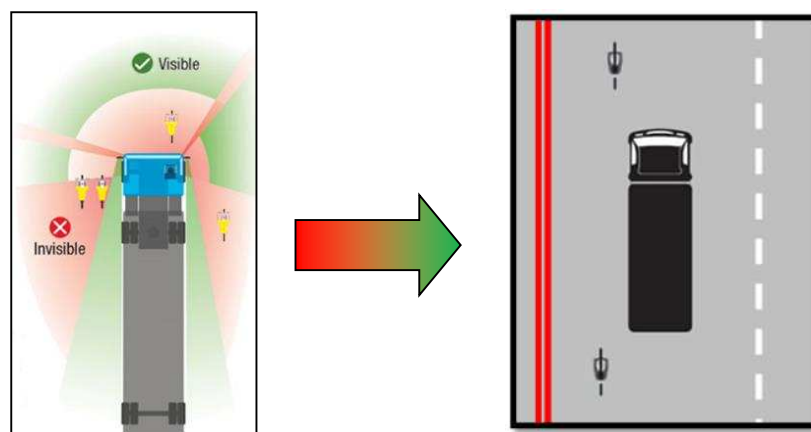

Figure 3: (a) Blind Sports Surrounding a Lorry, (b) Cyclist 360° Alert Driver's Display View

The Cyclist 360° Alert system requires the localisation and tracking of bicycles, as well as vehicles, in real-time, in order to deliver the proposed 360 view graphical representation, and the main challenge associated with this goal is the high positioning accuracy required for both road users groups. Specifically, Cyclist 360° Alert requires positioning with precise coordinates (in a Cartesian coordinate system) rather than merely an approximate location indication, and targets a minimum accuracy of 50 cm at a speed of 32 km/h, as lower accuracy than this may result in large positioning errors. However, bicycles are significantly smaller in comparison to HVs, only occupy a small amount of space and are able to move more freely than vehicles on the road, which makes their real-time tracking to the desired accuracy a difficult task. To the best of the authors’ knowledge, a single system fulfilling this requirement is not available as yet; hence a new approach is needed to achieve this. This should rely on existing technology, with cost being a major constraint on the development, as Cyclist 360° Alert needs to be a cheap solution that can eventually be integrated in all bicycles and HVs. A review of available localisation techniques and technologies is conducted next, including an assessment of their suitability.

**4. Localisation Techniques and Technologies**

Electromagnetic waves propagation in the “real” environment is subject to many issues such as multipath, absorption, diffraction and reflection (Rappaport, 2001), hence signals cannot be measured precisely. Therefore, there are many localisation algorithms which have been proposed in the literature (Farid, et al., 2013) and can be broadly categorised as “distance” and “angle” estimations for coordinate localisation systems. Although there are other algorithms available for localisation such as proximity estimation, the exact location coordinates cannot be determined because of the nature of information provided, and therefore they are not suitable for the Cyclist 360° Alert system.

On the other hand, the estimation of distances and angles is feasible within the Cyclist 360° Alert context, as it can be performed either directly from the signals- travelling between nodes, or by a two-step approach, in which certain parameters are extracted from the signals first, and then the position is estimated based on those signal parameters. The two-step approaches are less complex in comparison with the direct approach, and the two approaches offer similar performance for sufficiently high signal to noise ratios (SNRs) and signal bandwidths. Most practical systems employ the two-step approach, and therefore it is the one to be employed for Cyclist 360° Alert.

There are two basic positioning techniques for accurate localisation based on distance and angle estimation: lateration and angulation. These can be conducted on the basis of three main measurement parameters: signal strength, propagation-time and received angle. Hybrid approaches that use combinations of these measurement techniques are also possible (Sahinoglu, et al., 2011) (Najibi, 2013). Figure 4 illustrates an overview of the available measurement techniques and position estimation techniques, where the lowest level of the hierarchy consists of the five different measurement methods mentioned.

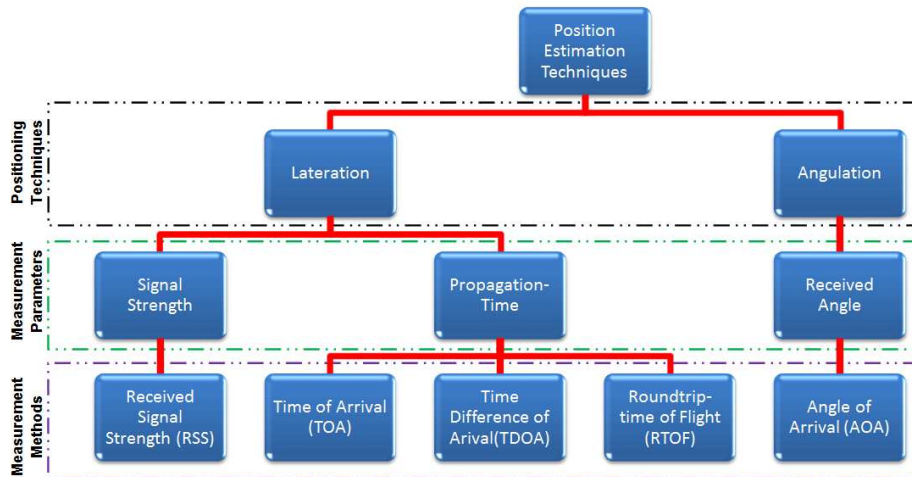

Figure 4: Classification of Localisation System

Using the two-step approach it is not possible to determine the precise coordinates of an object based on a single measurement method alone, as the measurement only provides information about the distance or the angle to it. Therefore, positioning techniques are used for localisation of an object and they can be divided into two categories: mapping (fingerprinting) and geometric or statistical techniques. A mapping technique is based on the use of a database containing signal measurements at known positions, which are surveyed beforehand. On the other hand, a geometric technique employs only the measurement parameters, without the support of a historical database.

Due to the nature of Cyclist 360° Alert, where the environmental characteristics vary significantly, only the geometric technique can be explored. In this technique there are two basic approaches; triangulation and trilateration. Trilateration is the most commonly used method, and is the one behind satellite positioning systems, such as the Global Positioning System (GPS). The unknown position of an object with at least three known stationary positions and distances to the object can be computed by employing Equation 1:

$$x = \frac{(x_1^2 + y_1^2 - d_1^2)(y_3 - y_2) + (x_2^2 + y_2^2 - d_2^2)(x_1 - x_3) + (x_3^2 + y_3^2 - d_3^2)((y_2 - y_1))}{2(x_1(y_3 - y_2) + x_2(y_1 - y_3) + x_3(y_2 - y_1))}$$

$$y = \frac{(x_1^2 + y_1^2 - d_1^2)(x_3 - x_2) + (x_2^2 + y_2^2 - d_2^2)(y_1 - y_3) + (x_3^2 + y_3^2 - d_3^2)((x_2 - x_1))}{2(y_1(x_3 - x_2) + y_2(x_1 - x_3) + y_3(x_2 - x_1))} \quad \text{Eq. 1}$$

Looking at existing localisation technologies, which are summarised in Table 1, it has been found that although most of them, such as GPS, Wi-Fi and Radio-frequency identification (RFID), can be utilised to estimate the location of an object, they do not provide sufficiently high resolution and accuracy to locate and track a bicycle in real time mainly due to its size and manoeuvrability. A technology, on the other hand, that could satisfy this technical requirement is Ultra-wideband (UWB), which has a maximum accuracy of 30 cm; however, current legislation restricts it to indoor usage only, in order to prevent harmful interference with other radio wave communications. Therefore, a single technology alone cannot be utilised to track a bicycle with a good accuracy to satisfy the requirements of Cyclist 360° Alert, instead a hybrid localisation system approach has to be adopted.

| Technology/System        | Wi-Fi  | RFID  | UWB                   | GPS  |
|--------------------------|--|---|-----------------------|--|
| <b>Range</b>             | 90-100m  | <100m                                       | <100m                 | worldwide  |
| <b>Accuracy</b>          | 1-5m   | 1-5m  | 30cm                  | 1-5m   |
| <b>Frequency Bands</b>   | 2.4GHz<br>3.6GHz<br>5Ghz                                 | 125KHz<br>13.56MHz<br>860-950MHz<br>2.45GHz | 3.1GHz to<br>10.6 GHz | L1:<br>1575.42MHz  |
| <b>Interference</b>      | Interference at<br>2.4GHz (ISM)<br>with other<br>devices | Other radio<br>frequency,<br>noise          | Bluetooth GSM         | signal<br>interference,<br>jamming,<br>multipath<br>interference |
| <b>Bandwidth/Channel</b> | 20MHz<br>(802.11n:<br>40MHz)                             | 60MHz                                       | 500 MHz               | 24MHz  |
| <b>Sample/Data rate</b>  | 1Mbps, 2Mbps,<br>11Mbps,54Mbps                           | 1Mbps                                       | 110Mbps<br>480Mbps    | 50bps  |
| <b>Antenna type</b>      | Omni-directional   | Omi-directional                             | Omi-directional       | Requires<br>Line-Of-Sight  |
| <b>Cost</b>              | Medium   | Medium                                      | High                  | Low  |

Table 1: Summary of the Four Localisation Technologies

## 5. Overall System Architecture

Figure 5 illustrates the overall system architecture diagram of Cyclist 360° Alert. The system requires the bicycle to be equipped with MEMS gyroscope and accelerometer sensors. It also requires a Hall effect sensor, an intelligent Wi-Fi tag (Wi-Fi iTag) and a roadside unit together

with Wi-Fi stations. The Wi-Fi iTag takes sample measurements of the bicycle's motion, based on its steering angle, tilt angle and speed. The data from the Wi-Fi iTag is then transmitted via a Wi-Fi local area network link, where at least three receivers receive the signal, to a server. Using appropriate data fusion techniques, the trajectory path of the bicycle is computed within the server. The coordinates of the trajectory path(s) are then be transmitted via the same Wi-Fi network to in-vehicle display units such as smart-phones or tablet PCs. The display unit computes the cyclist's position within the vicinities of vehicles, and creates a graphical representation of this position, such as the one illustrated in Figure 3 (b). The system architecture also employs cameras to locate bicycles on the road, and this information is utilised to adjust any localisation errors in real-time. Hence, Cyclist 360° Alert may delivers high accuracy positioning for the collision prediction system, which is to be developed in the later stages of the project.

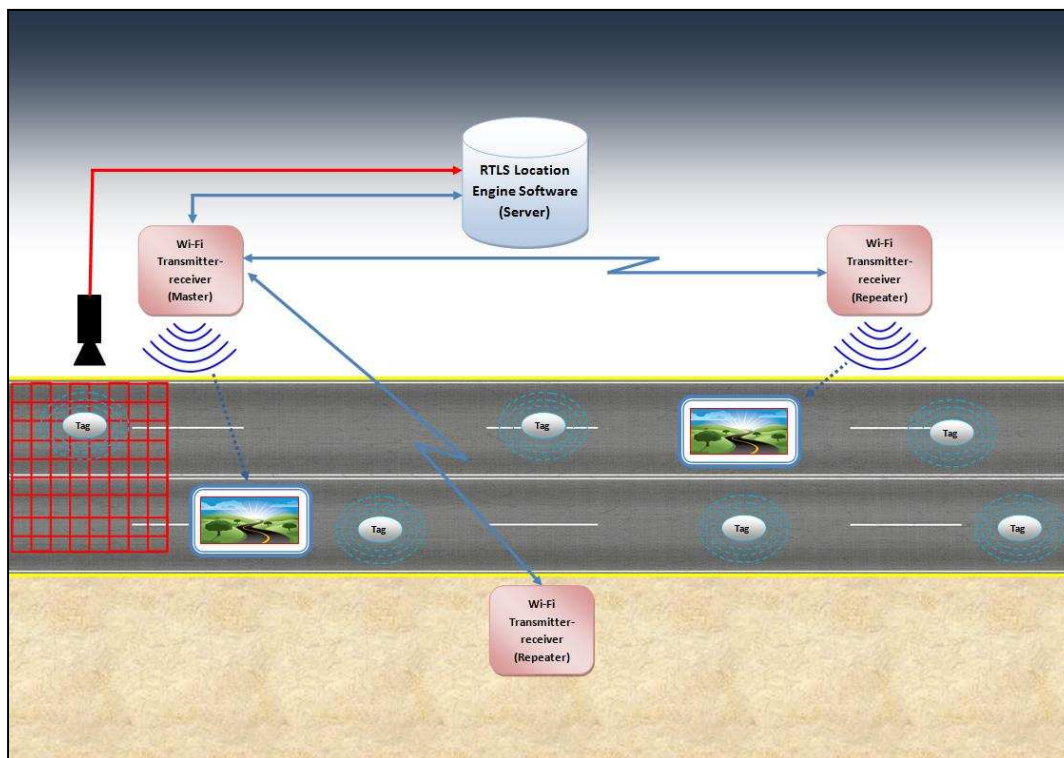

Figure 5: Overall System Architecture Diagram

The development of the complete Cyclist 360° Alert system is complex and consists of several phases. The present study relates to the first phase, whose objective is to develop a prototype instrumented bicycle with sensors, called iBike, with objective to track and measure its motion parameters. This first phase of system is the foundation for the entire system.

## 6. iBike and Data Visualisation System

The present study focuses on equipping a Barclays Cycle Hire Bicycle, supplied by TfL for this purpose, with MEMS gyroscopes, MEMS accelerometers, optical encoders and Hall effect sensors. The three main variables, which are to be continuously monitored and sampled using the sensors, are the wheels' Revolutions Per Minute (RPM) rate, and the bicycle's roll angle and yaw angle. These variables are then to be employed to determine the trajectory of the bicycle using a mathematical model for the motion in the ground plane. The data from the iBike is then to be transferred to the server for data fusion, in order to compute the trajectory. Figure 6 (a) illustrates the iBike system that enables taking sample measurements from the on-board sensors.

Following completion of the instrumentation, it is planned to test the iBike by riding it on a designated track, where cameras are to be used to capture the motion and act as the ground truth, so that the actual bicycle's path can be compared with the computed trajectory based on the on-board sensor data. The data from the iBike is to be post-processed at this stage by

developing a data visualisation system on a PC. This visualisation system is to convert the raw data from the iBike into trajectory information and display it in a 2D map. The graph in Figure 6 (b) illustrates an example of such a 2D map, together with an extracted trajectory after the sensor data have been processed through the data visualisation system.

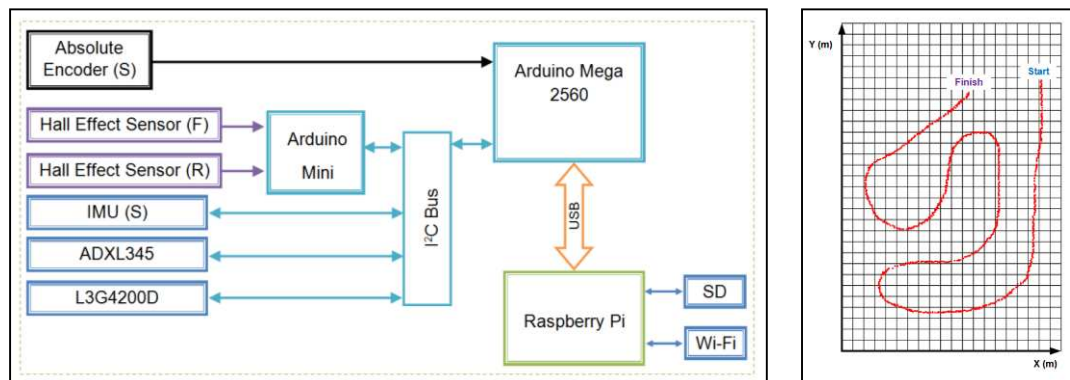

Figure 6: (a) iBike Data Capturing System, (b) Trajectory Output on a 2D Map

### 6.1 iBike Simulator Model

The MEMS gyroscope sensors do not output “angles” directly, but provide the instantaneous angular rates, caused by the change in motion, instead. Similarly, the MEMS accelerometer sensors only provide acceleration due to motion or shock and acceleration due to gravity in tilt-sensing applications. Therefore, both sensors’ data needs to be converted so as to be used in the application of measuring the roll and yaw angles of the bicycle. In addition, the gyroscope sensors often only provide very accurate angular rates momentarily in dynamic situations, whereas the accelerometer sensors provide accurate acceleration data mostly in static situations. As a result, often these two sensors’ data are combined to obtain accurate angles measurement information. To obtain an initial set of data from the sensors and to examine the measurement accuracy of angles in static and dynamic conditions, an iBike simulator model has been constructed and a 3D CAD model of the iBike simulator model is illustrated in Figure 7. Thus, this simulator model is employed to obtain the first sets of data from the gyroscope and accelerometer sensors in a controlled environment, where the model is controlled from a PC with desired yaw and roll angles. A summary of the results from the experiments are shown in the following sections.

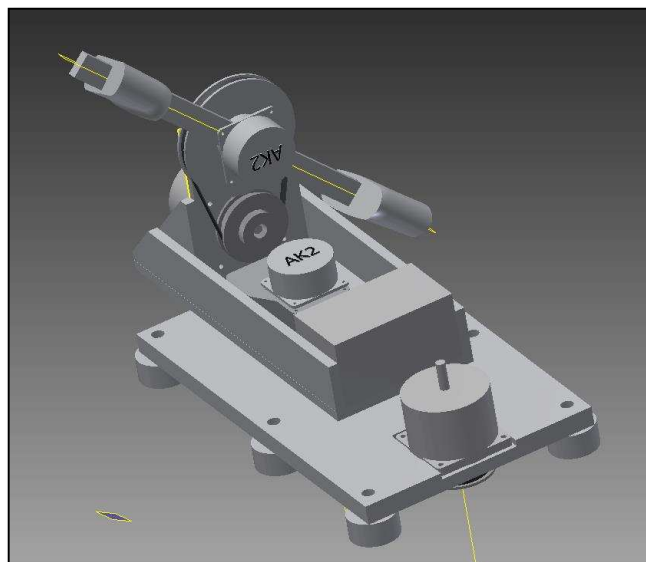

Figure 7: iBike Simulator CAD Model

### 6.2 Experimental Setup

The gyroscope and the accelerometer sensors are attached to the handle bar of the iBike simulator model, which has the same length as the actual bicycle, placed 10cm away from the centre of the handle bar. Two different pieces of software have been developed to conduct the



experiments: - the first one is a graphical user interface to control the iBike simulator model, with the purpose of sending control commands to the model and of varying different aspects, such as steering angle, transition delays and transition speeds; the second one is also a graphical user interface that allows the visualisation of incoming data in real-time from the sensors through 3D rectangular cubes, representing the sensors' motions. In other words, the cubes are rotated in the x, y, and z-axes according to the incoming data from the sensors, which are connected with the model. As a result, the interface allows observing the behaviour of the sensors in real-time, and allows capturing and storing of measurements in real-time in plain text format, and used for post-processing.

Two different methods are applied to fetch the sensors' data from the simulator: the first one is used to collect the sensors' data at different angles while the sensors are momentarily stationary at the angles; and the second one is used to capture the sensors' data at different angles, while they are in motion.

### 6.3 Experiments with Sensors in Stationary

In the first category of experiments the behaviour of the sensors at different stationary positions is observed when only varying the roll (tilt) angle and fixing the yaw (steering) angle at a position. In other words, this experiment is designed to observe the roll angles and behaviour of the sensors immediately after a transition. The following points provide further information regarding the setup:

- Stationary roll angles: 0°, 9°, 18° and 27°
- Average time for each sample: 26 ms
- Baud rate: 115200 bps
- Steering angle: 0° (fixed at a position)
- Number of samples at each stationary point: 256
- Total number of samples: 1024
- Maximum rpm of the roll motor: 18 rpm
- Maximum delay in between each transition: 30000 ms

The graphs in Figure 8 and Figure 9 illustrate the sensors' data at different stationary points of the roll angles. For instance, the accelerometer data in the experiment clearly indicate the change of angles, represented by the green and black lines which are the y and Z axes respectively. The blue vertical lines represent different blocks of the angles' raw data and each block contains 256 samples of data. The gyroscope raw data only shows the noise data, as it was captured in stationary positions.

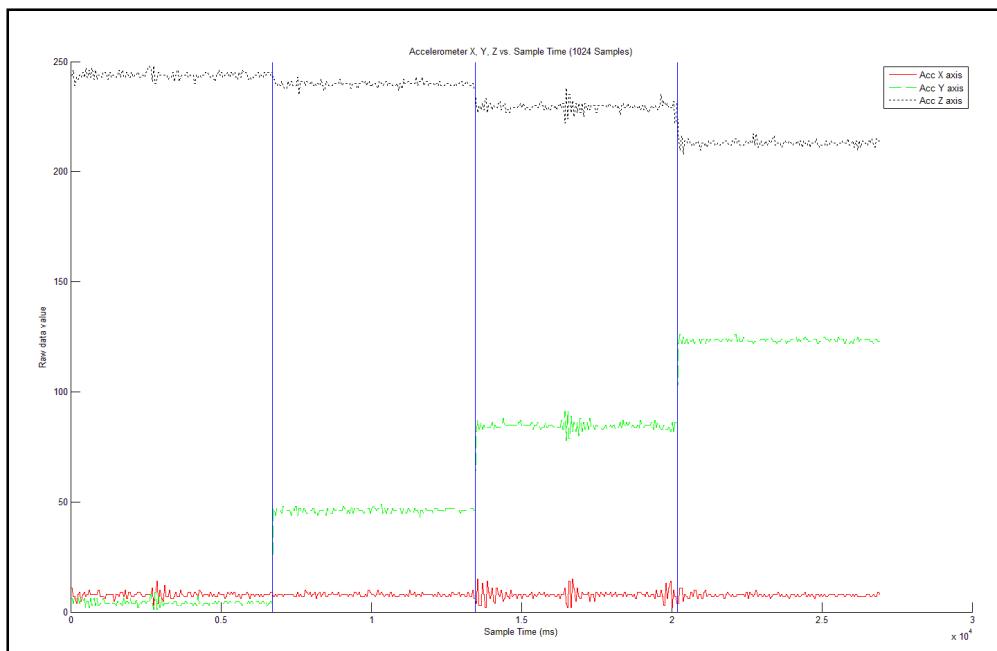

Figure 8: Accelerometer Raw Data at Stationary Roll Angles

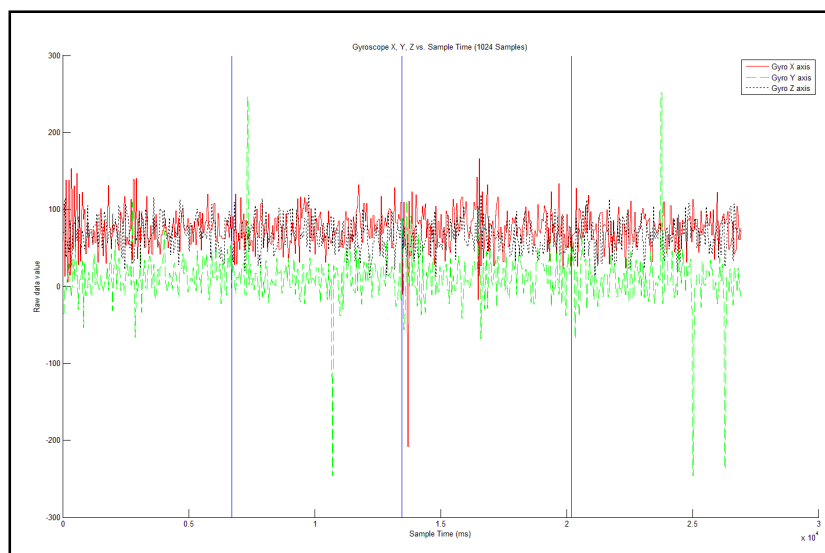

Figure 9: Gyroscope Raw Data at Stationary Roll Angles

#### 6.4 Experiments with Sensors in Motion:

The second category of experiments is used to observe the behaviour of the sensors while they are in motion. In other words, this experiment has been designed to capture the sensors' data between the transition periods from one stationary angle to another. In this setup only the roll angle is varied and the yaw angle is kept at a fixed position. The following points give further information regarding the setup:

- Motion roll angles: 0° to 9°, 9° to 18°, 18° to 27° and 27° to 36°
- Average time for each sample: 26 ms
- Baud rate: 115200 bps
- Yaw angle: 0° (kept fixed during this experiment)
- Number of samples at each motion roll angle: 256
- Total number of samples: 1024
- Maximum rpm of the roll motor: 18 rpm
- Maximum delay in between each transition: 30000 ms

The graphs in Figure 10 and Figure 11 illustrate the sensors' data in motion at different roll angles. In this case both the accelerometer and gyroscope data clearly indicate the transition between the roll angles. For instance, the gyroscope raw data for the x-axis, represented by the red line, clearly shows the angular rate when the sensor is in motion.

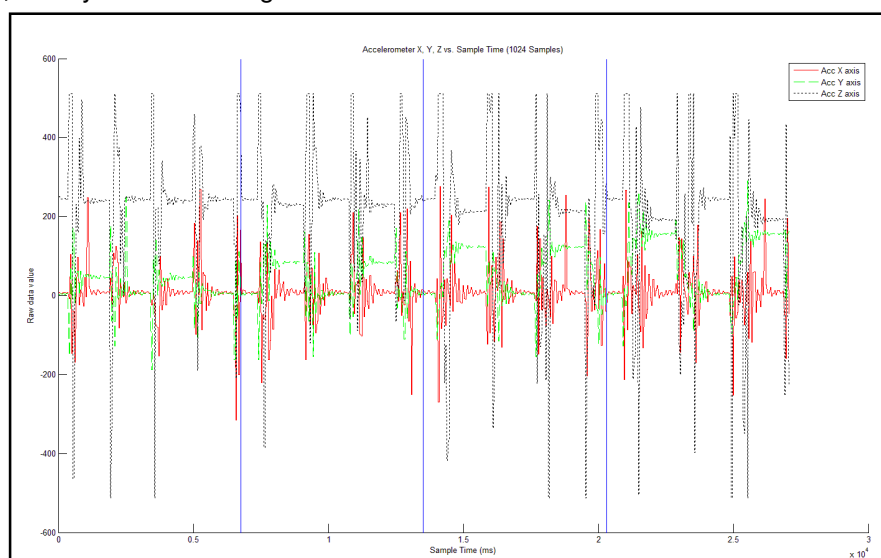

Figure 10: Accelerometer Raw Data in Motion

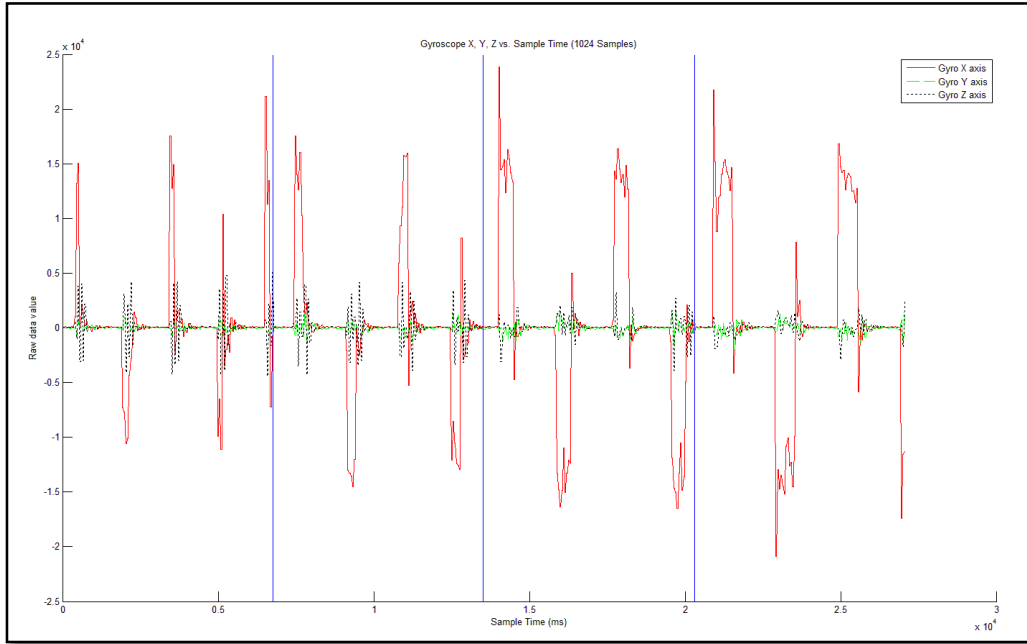

Figure 11: Gyroscope Raw Data in Motion

The graph in Figure 12 shows the converted angles for from the sensors' data together with filtered angles through a simple Kalman filter. As can be seen, although the sensors' data somewhat represent the transition angles from the experiment, the data cannot be directly employed to compute the steering and tilt angles for the iBike localisation system. The noise associated with the sensors' data is likely to cause inaccuracies in the localisation system, although the simple Kalman filter removes some of the noise; a further study needs to be conducted to filter out the noise completely using more complex Kalman filtering algorithms.

In conclusion, the graphs in this section illustrate an interesting result: apart from the noise in the data, they represent the motion of the simulator model as commanded from the PC, and can therefore be converted to more useful information with additional signal processing so as to capture the motion of a bicycle.

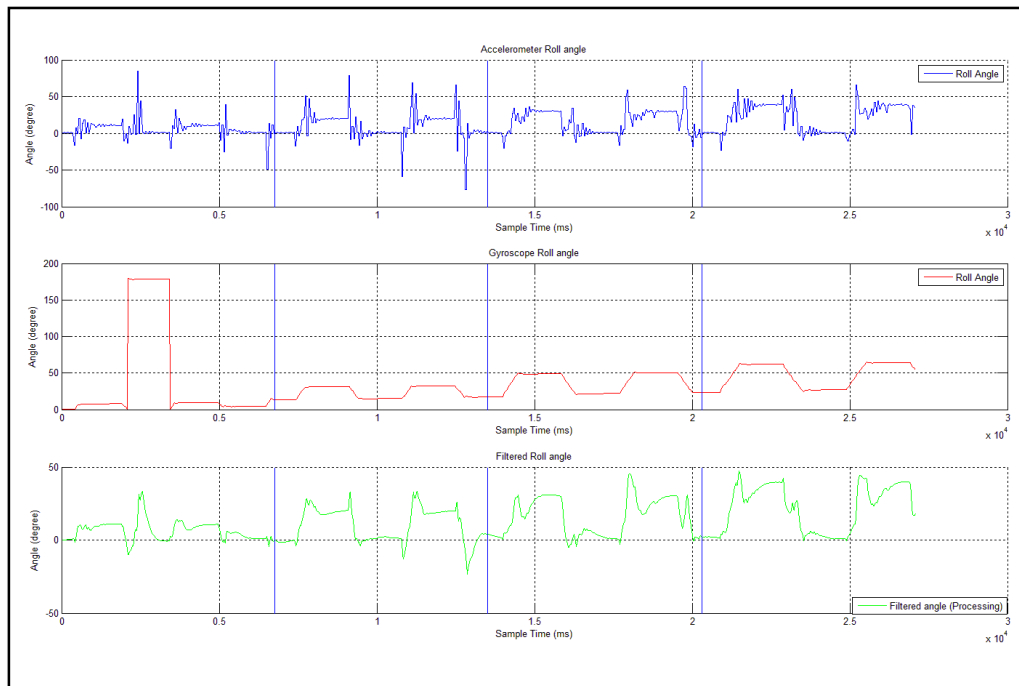

Figure 12: Accelerometer, Gyroscopes and Filtered Angles

The results of the experiments carried out with the iBike simulator model highlight the behaviour of the sensors when they are both stationary and in motion. The data presented almost match with the theoretical output from the sensors, such as the gyroscope data, when stationary. The measurements do not indicate a clear change of angles, but rather the noise of the gyroscope. Furthermore, the accelerometer measurement data clearly indicate the changes of roll angles, even when the sensor is stationary. Therefore, these sensors can be employed to measure the roll and yaw angles of a bicycle's motion but a suitable filtering procedure has to be implemented to reduce the effect of noise. An accurate model of the bicycle's motion will reduce the noise, as the process noise covariance (Q) and measurement noise covariance (R) would be more accurate. Work is currently under way to develop a model for the bicycle's motion in the ground plane.

## 7. Conclusion and Future Work

With bicycle-related accidents with HVs, especially in cities, being a growing problem in modern society and many stakeholders seeking to find solutions, this paper presents the first stage of the development of the timely Cyclist 360° Alert system, which aims at addressing this problem. Considering that one of the main causes of accidents between cyclists and HVs is that the driver cannot see the cyclist due to their small size and their erratic movement, a system architecture design was formulated, which is to provide the driver with an aerial view of their vehicle through the use of localisation systems. The system relies on an instrumented bicycle (iBike) MEMS sensor configuration, and preliminary results obtained from testing in a controlled environment using a 3D model have demonstrated the appropriateness of the approach.

The iBike concept alone has many applications, aside from being an enabler of the Cyclist 360° Alert system. For example, iBikes can be used to collect environmental data to monitor air quality or to identify common cycling paths in busy junctions, even going as far as triggering priority at traffic lights at certain times. The concept can also be employed to enhance anti-theft systems, as well as to transmit assist emergency services in case of accidents by transmitting the location of the bicycle involved. In an increasingly congested urban environment more and more people will be attracted to travelling by bicycle if they think cycling is a safe alternative mode, and the iBike concept can contribute to that vision by offering an innovative low-cost technological solution.

Further work will concentrate on developing the next steps of iBike and Cyclist 360° Alert. Firstly, a further study on the kinematics of bicycles will be conducted to develop and validate a mathematical model for the motion in the ground plane. The model will then be simulated to examine the accuracy. Then, the model will be utilised to compute the process noise covariance and measurement noise covariance for the Kalman filter, and the filter will be re-implemented to remove the noise from the sensor data. At the same time, the iBike will be equipped with the sensors together with an embedded system to capture its motion data for post-processing. Experiments will be conducted with the iBike in order to compute the trajectory based on the sensors' data, the localisation accuracy of the Cyclist 360 Alert system will be compared with other localisation systems.

## References

Anon., 2013. *West Dulwich lorry-collision cyclist killed*. [Online] Available at: <http://www.bbc.co.uk/news/uk-england-london-23959657> [Accessed 16 October 2013].

DfT, 2012. *Reported Road Casualties in Great Britain: 2012 Annual Report*. [Online] Available at: [https://www.gov.uk/government/uploads/system/uploads/attachment\\_data/file/245149/rrcgb2012-01.pdf](https://www.gov.uk/government/uploads/system/uploads/attachment_data/file/245149/rrcgb2012-01.pdf) [Accessed 18 March 2014].

DfT, 2014. *Reported Road Casualties in Great Britain: Quarterly Provisional Estimates Q3 2013*. [Online] Available at: [https://www.gov.uk/government/uploads/system/uploads/attachment\\_data/file/277527/road-](https://www.gov.uk/government/uploads/system/uploads/attachment_data/file/277527/road-)

---

[accidents-and-safety-quarterly-estimates-q3-2013.pdf](#)

[Accessed 14 March 2014].

Farid, Z., Nordin, R. & Ismail, M., 2013. Recent Advances in Wireless Indoor Localization Techniques and System. *Computer Networks and Communications*, Volume 2013, p. 12.

Hollan, J., Hutchins, E. & Kirsh, D., 2000. Distributed Cognition: toward a new foundation for human-computer interaction research. in *ACM Transactions on Computer-Human Interaction*.

Kuster, F., Laurence, C. & Geffen, R., 2010. *Halving injury and fatality rates for cyclists by 2020*. [Online]

Available at: [http://www.ecf.com/wp-content/uploads/2011/10/ECF Road safety charter.pdf](http://www.ecf.com/wp-content/uploads/2011/10/ECF_Road_safety_charter.pdf)  
[Accessed 28 September 2012].

Morgan, A. S., Dale, H. B., Lee, W. E. & Edwards, P. J., 2010. *BMC Public Health*. [Online]

Available at: <http://www.biomedcentral.com/content/pdf/1471-2458-10-699.pdf>

[Accessed 1 October 2012].

Najibi, M., 2013. *Localization Algorithms in a Wireless Sensor Network Using Distance and Angular data*, Burnaby: SIMON FRASER UNIVERSITY.

Ofcom, 2014. *The Communications Market Report 2014*. [Online]

Available at: [http://stakeholders.ofcom.org.uk/binaries/research/cmr/cmr14/2014\\_UK\\_CMV.pdf](http://stakeholders.ofcom.org.uk/binaries/research/cmr/cmr14/2014_UK_CMV.pdf)

[Accessed 11 August 2014].

Rappaport, T. S., 2001. *Wireless Communications: principles and practice*. s.l.:Prentice Hall.

RoSPA, 2013. *Cycling Accidents - Facts and Figures*. [Online]

Available at: <http://www.rospa.com/roadsafety/adviceandinformation/cycling/facts-figures.aspx>

[Accessed 16 October 2013].

Sahinoglu, Z., Gezici, S. & Güvenc, I., 2011. *Ultra-wideband Positioning Systems*. 1st ed. New York: Cambridge.

Schoon, C., 2006. *SWOV*. [Online]

Available at: [http://cardweb.swov.nl/swov/website\\_uk\\_detail.html?Search=Search&display=1&pg=q&q=r20062&start=0](http://cardweb.swov.nl/swov/website_uk_detail.html?Search=Search&display=1&pg=q&q=r20062&start=0)

[http://cardweb.swov.nl/swov/website\\_detail.html?Zoek=Zoek&display=1&pg=q&q=r20062&start=0](http://cardweb.swov.nl/swov/website_detail.html?Zoek=Zoek&display=1&pg=q&q=r20062&start=0)

[Accessed 24 November 2014].

SWOV, 2012. *SWOV Fact sheet: Blind spot crashes*. [Online]

Available at: [http://www.swov.nl/rapport/Factsheets/UK/FS Blind spot crashes.pdf](http://www.swov.nl/rapport/Factsheets/UK/FS_Blind_spot_crashes.pdf)

[Accessed 24 November 2014].

TfL, 2008. *Barclays Cycle Superhighways*. [Online]

Available at: <http://www.tfl.gov.uk/modes/cycling/routes-and-maps/barclays-cycle-superhighways>

[Accessed 01 November 2014].

TfL, 2010. *BARCLAYS CYCLE HIRE*. [Online]

Available at: <http://www.tfl.gov.uk/modes/cycling/barclays-cycle-hire>

[Accessed 01 November 2014].

The Times, 2013. *Cities fit for cycling*. [Online]

Available at: <http://www.thetimes.co.uk/tto/public/cyclesafety/article3313260.ece#tab-1>

[Accessed 24 November 2014].

---