

THE UNIVERSITY OF WARWICK

Original citation:

Bernhardt, Daniel and Graham, Brett. (2015) Multi-product Bertrand Oligopoly with exogenous and endogenous consumer heterogeneity. *The B.E. Journal of Theoretical Economics*, 15 (2). pp. 167-209.

Permanent WRAP url:

<http://wrap.warwick.ac.uk/76988>

Copyright and reuse:

The Warwick Research Archive Portal (WRAP) makes this work of researchers of the University of Warwick available open access under the following conditions. Copyright © and all moral rights to the version of the paper presented here belong to the individual author(s) and/or other copyright owners. To the extent reasonable and practicable the material made available in WRAP has been checked for eligibility before being made available.

Copies of full items can be used for personal research or study, educational, or not-for-profit purposes without prior permission or charge. Provided that the authors, title and full bibliographic details are credited, a hyperlink and/or URL is given for the original metadata page and the content is not changed in any way.

Publisher's statement:

"The final publication is available at www.degruyter.com"

<http://dx.doi.org/10.1515/bejte-2014-0031>

A note on versions:

The version presented in WRAP is the published version or, version of record, and may be cited as it appears here.

For more information, please contact the WRAP Team at: publications@warwick.ac.uk

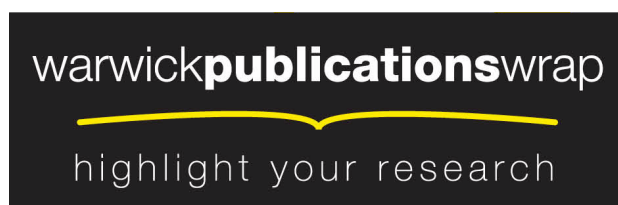

<http://wrap.warwick.ac.uk/>

Contributions

Dan Bernhardt and Brett Graham*

Multi-product Bertrand Oligopoly with Exogenous and Endogenous Consumer Heterogeneity

Abstract: We develop a spatial model in which consumers receive firm-specific location shocks and firms endogenously determine both franchise/product locations and prices. Remarkably, firms fail to profit from endogenous product-specific heterogeneity alone: while ex-post consumer heterogeneity ensures positive gross profits, competition for market share results in socially excessive product lines and zero net profits. With added exogenous taste heterogeneity, endogenous spatial heterogeneity drives profits below their levels with only taste heterogeneity. Finally, we introduce multiple product lines and show that when product costs differ across lines, firms earn positive profits as long as consumer preferences over lines are imperfectly correlated.

Keywords: spatial modeling, product line competition, endogenous location, spatial heterogeneity, taste heterogeneity, franchising

JEL Classifications: L1, L11, L13

DOI 10.1515/bejte-2014-0031

1 Introduction

What happens when firms compete using both product locations and prices? More concretely, how does Coca-Cola compete against PepsiCo, or Wendy's compete against Burger King, and how successful will they be at exploiting endogenous product-specific heterogeneity to extract profits?

*Corresponding author: **Brett Graham**, Wang Yanan Institute for Studies in Economics, Xiamen University, 422 Siming South Road, Siming, Xiamen, Fujian Province, 361006 China, E-mail: bgraham.wise@gmail.com

Dan Bernhardt, Department of Economics, University of Illinois, Champaign, IL, USA; Department of Economics, University of Warwick, Coventry CV4 7AL, UK, E-mail: danber@illinois.edu

To get at these questions, we develop a novel spatial structure in which consumers receive *firm-specific* location shocks, so that a consumer's location relative to one firm's product line/franchise network is uncorrelated with his location relative to a rival's product line. The other features of the economy are standard. First, firms choose product locations and prices. Then, consumers receive spatial location shocks and choose where to shop. In our base model, the only source of consumer heterogeneity is the spatial heterogeneity that firms endogenously introduce via their location choices. When consumers are distributed uniformly across spatial locations, firms optimally spread their products evenly and set the same price at each product location. Prices reflect only the average properties of the two networks – summarized by each firm's concentration of product locations.

With these results in hand, we characterize equilibrium product/franchise concentration and pricing. The ex-post heterogeneity in consumer location reduces the elasticity of demand, and hence price competition. It follows directly that firms price above marginal cost and generate positive gross profits, i.e. profits before consideration of product creation/location costs. What is remarkable is that these gross profits *just* cover the product creation costs. That is, the competition for market share via product concentration *completely exhausts* the profits generated by the ex-post heterogeneity. We prove that this qualitative finding extends when there is additional firm heterogeneity so that one firm has a “better product”, one that, *ceteris paribus*, all consumers prefer, and/or has lower costs of product development: in equilibrium, the “disadvantaged” firm earns zero net profits.

From a social welfare perspective, the competition between firms for market share results in over-provision of products – in equilibrium, firms create more products than would a social planner. Because higher product concentrations imply lower prices, a direct implication is that firm profits are lower and consumer surplus is higher in the competitive equilibrium, than they would be were the social planner to choose product locations.

We then allow for exogenous heterogeneity in consumer preferences between firms, so that, for example, ex-ante, some consumers prefer Coca Cola's soda, while others prefer PepsiCo's. It is immediate that, in equilibrium, firms can exploit exogenous heterogeneity in tastes to extract positive net profits. What is surprising is the extent to which competition on endogenous spatial dimensions spills over to reduce the profits that firms derive from exogenous taste heterogeneity. Indeed, in the neighborhood of zero taste heterogeneity, the intensified price competition associated with endogenous spatial heterogeneity causes firms to compete away fully three-quarters of the possible profit gain from introducing slight taste heterogeneity. The profit loss due to

competition on product location *grows* as taste heterogeneity increases up to the point where there is so much exogenous taste heterogeneity that the price in the economy without the endogenous spatial dimension is the same as that when the spatial dimension is present. At this point, firms extract no benefits from the products that they establish: *all* product creation costs are, in essence, wasted.

We conclude by extending our model to a multi-product line setting in which each firm is associated with two product lines (say sodas and juices). Correlation in taste across product lines implies a consumer whose most preferred product from one firm is a soda is more likely to most prefer a soda from a rival. While a preference for Coke could reveal a likely preference for sodas over juices, we maintain the assumption that this preference for Coke reveals nothing about preferences for Diet Pepsi versus Pepsi.

Correlation alone does not change our findings: with perfectly positively correlated preferences, so that a consumer either prefers sodas from both firms or prefers juices, inter-firm competition decomposes into two competitions, one over soda and one over juice. Our earlier analysis then implies that firms compete all profits away.

Matters are very different when (a) preferences are imperfectly correlated so that a consumer who prefers a soda from one firm may prefer a rival's juice **and** (b) product provision costs differ across product lines, so that juices are more expensive to develop than sodas. Firms still compete away all profits from their disadvantaged (e.g. expensive) product lines, but they earn positive profits from their advantaged (e.g. inexpensive) products. Specifically, a firm profits from consumers who prefer its advantaged product, but its rival's disadvantaged product. The reason is that firms stock their advantaged product line more extensively. As a result, for some consumers, a firm's advantaged line competes against itself rather than against a rival's disadvantaged product line – some consumers will prefer multiple products on a firm's advantaged line to any of the rival's products. Firms internalize this own product line competition, and do not expand their disadvantaged product lines to the same extent. In turn, this reduces the intensity of price competition, allowing firms to earn strictly positive profits. Interestingly, while profits go to zero as the correlation in preferences across product lines goes to one, profits do *not* globally decline in this correlation: raising the probability that a consumer who likes one firm's advantaged product likes a rival's disadvantaged product *lowers* profits once this probability is high enough.

The paper's outline is as follows. We next discuss related research. Section 2 shows that an optimal response to any product line design of a rival features identical pricing of each product and product locations that deliver equal market shares for each product. We then assume these features and treat the number of a firm's products as a continuous variable, focusing on product *concentrations*.

Section 3 develops our core continuous model with two symmetric firms. We proceed to consider an asymmetric duopoly. The section concludes by contrasting equilibrium outcomes with that preferred by a social planner. Section 4 explores how heterogeneous consumer tastes affect outcomes. Section 5 investigates competition between firms with multiple product lines. Section 6 concludes. Proofs are given in Appendix.

1.1 Methodology and related research

Using spatial concepts to model economic phenomena, and market structure in particular, dates back to Hotelling (1929). Subsequent notable contributions include Lancaster (1971), d'Aspremont, Gabszewicz, and Thisse (1979) and Salop (1979). Existing research on competition in product lines have largely focused on product customization by either endogenizing the range of appeal for a single product, supposing that firms provide a product characterized by an interval $[a, b]$ (see Dewan, Jing, and Seidmann (2000); Dewan, Jing, and Seidmann (2003) or Alexandrov (2008)) or by allowing firms to acquire costly information about individual consumer preferences that allow product customization (Bernhardt, Liu, and Serfes 2007) to a representative consumer.¹

Other research has focused on the impact of consumer's preference for variety on multi-product firm strategic interaction. Klemperer (1992) models product-line competition between two spatially separated "grocery stores", asking whether they would do better to compete head-to-head on product lines or to have "interspersed" product lines. When grocery stores sell distinct, "interspersed" products, some consumers may patronize both stores in order to buy more preferred bundles of products, which they would never do were product lines identical. Patronizing both stores can serve to enhance price competition, even though the individual products of the two stores are imperfect substitutes, lowering firm profits. Peng and Tabuchi (2007) combine a model of monopolistic competition over variety à la Dixit and Stiglitz (1977) within a store with an address model of multiple stores to capture sensitivity of demand to location. The set of possible spatial configurations in this environment is large.

The limited research on product line competition reflects the challenges of solving for equilibrium outcomes when product location and pricing is

¹ In contrast to the symmetric equilibrium in our economy, quality provision is asymmetric in Bernhardt, Liu, and Serfes (2007), with one firm making a minimal investment in product-customizing capabilities in order to mitigate the ensuing price competition: by not acquiring detailed information about customers, a firm credibly commits to ineffectively targeting consumers, inducing its rival to raise its price.

endogenous. To ensure that a posited set of (price, location) strategies is an equilibrium, one must verify that *no* deviation in location or prices can raise profits – and in standard spatial settings, pure strategy equilibria typically do not exist. Vogel (2008) solves for equilibrium locations and prices when firms have a *single* product and heterogeneous marginal costs. His insight was that one did not need to fully characterize off-equilibrium mixed-strategy outcomes to determine the equilibrium path. However, there is no clear way to extend his approach to competition in product lines. Rather than confront such challenges head-on, like us, Chen and Riordan (2007) create a clever spatial structure. In their star and spoke model, at the end of each spoke a firm is possibly located with a product, and consumers are uniformly distributed over spokes. Each consumer values the product at the end of her spoke, and with equal probability values the product at the end of *one* other spoke. This preserves symmetry, facilitating analysis.

To obtain existence, de Palma et al. (1985) add heterogeneous consumer tastes that are orthogonal to the spatial dimension using a multinomial logit specification: with sufficient consumer heterogeneity, equilibria in pure strategies exist when firms compete simultaneously over both price and location of a single product. Janssen, Karamychev, and van Reeve (2005) extend this idea to multi-product firms by using a uniform distribution for consumer heterogeneity, *assuming* that a firm charges the same price for each of its products, and that some consumers at each location have strong enough preferences for one firm that they always choose to patronize that firm. This means that a firm has a dominant strategy to locate products so as to minimize the sum of transportation costs to its product line if all consumers were to patronize that firm. Their setting delivers very different prediction from our model that prices are independent of the number of outlets. Moreover, we exploit the tractability of our framework to provide a far more complete characterization of equilibrium outcomes (e.g. comparative statics on product line variety, characterizations of firm profit and welfare, impact of heterogeneity of firms and multi-line competition).

It is worth noting how the structure of demand within and across firms associated with our consumer heterogeneity differs from previous work on multi-product firm competition. The demand structure in the papers that use orthogonal consumer heterogeneity preserves the underlying nature of competition in the original Hotelling model. Marginal changes in location or price of a product only affect the demand of the two nearest-neighboring products regardless of firm identity. Papers using vertical differentiation to examine multi-product firm competition also have this feature (see Champsaur and Rochet (1989), Johnson and Myatt (2006) or Yi-Ling, Peng, and Tabuchi (2011)). In contrast, our structure leads to changes in demand of the two nearest-neighboring own-firm products and to changes in demand for all of the competing firm's products. Our demand

structure can also be compared to the non-address nested demand model of multi-product firms introduced by Anderson and de Palma (2006), wherein demand cross-price elasticity is higher across a firm's product range than the cross-price elasticity between competing firm products. The different demand structures lead to very different results – in contrast to our prediction that each firm offers more products in equilibrium than is socially optimal, Anderson and de Palma (2006) predict that each firm offers too few products. In their study of the design of ATM networks, Bernhardt and Massoud (2005) use a similar demand structure for ATM usage but first require consumers to choose a bank membership, for which consumers have endogenously imposed heterogeneous tastes. Similar to our findings, they find that firms over invest in ATM networks in order to compete for customers.

This demand structure gives our model tractability even in asymmetric settings in which firms are heterogeneous along multiple dimensions. The tractability is due to the coarse information conveyed to a firm by the nature of a consumer's preference for its most preferred product about the intensity of preferences for a competitor's products: a consumer's distance to its preferred firm A product can convey information about *which* firm B product line is closest (juice or soda), but it reveals nothing about the intensity of those preferences within that product line. This simplifying abstraction is the polar opposite of the standard spatial assumption that a consumer's preference for Diet Pepsi relative to Pepsi *exactly* determines the preference for Coke relative to Sprite that delivers the prediction that pricing depends on every fine detail, rendering analysis infeasible.

2 Discrete product model

Our core model develops a spatial oligopoly game between two firms, A and B . The firms compete to sell their goods to measure one of consumers. Each firm is associated with its own spatial circle along which consumers are uniformly distributed. We normalize the circumference of each circle to one. A firm chooses where on its spatial circle to establish its products. Consumers who purchase a product distance d from their location incur a disutility cost of Td , where $T > 0$.² It costs a firm $F > 0$ to establish a product: the total cost to firm $j \in \{A, B\}$ of n_j products is $n_j F$. The marginal cost of production is constant and normalized to 0. Firms seek to maximize profits.

We index firm j 's products by $1, 2, \dots, n_j$, and let $N_j = \{1, \dots, n_j\}$. We define l_{ji} to be the location of the i^{th} product of firm j . Without loss of generality we

² Our central results extend when consumers incur quadratic disutility costs, Td^2 .

normalize the location of product j_1 to $l_{j_1} = 0$ and order products so that $l_{j_i} < l_{j_{i+1}}$. One can interpret product locations as the characteristics locations (e.g. of Coca-Cola soft drink flavors) of a firm’s product line or as the store locations (e.g. of Wendy’s franchises) in a franchise network. Firm j charges price p_{j_i} for its product j_i . A strategy for firm j is a *product line profile* $S_j = [n_j, \{l_{j_i}, p_{j_i}\}_{i=1}^{n_j}]$ that *simultaneously* specifies the number of products, each product location, and the price set for each product.³ The set of possible product line profiles for firm j is Σ_j .

A consumer receives utility V from the homogeneous good that the two firms sell. We assume that V is large enough that, in equilibrium, all consumers purchase the good. After firms simultaneously choose product line profiles, consumers receive firm-specific location shocks, d_A and d_B . For firm j , a given consumer c is equally likely to be located at any point on firm j ’s circle, and c ’s location on firm A ’s spatial circle is uncorrelated with his location on firm B ’s spatial circle. Figure 1 shows a potential location realization for consumer c . These location shocks could reflect product characteristic differentiation with

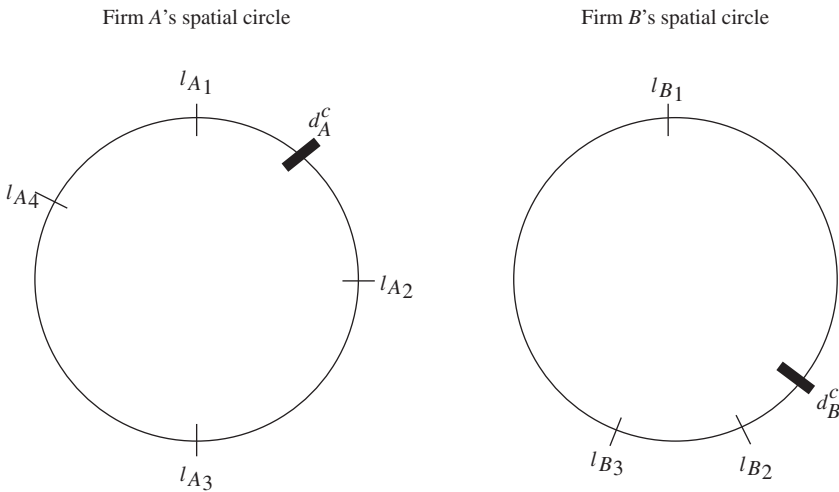

Figure 1: Consumer c ’s location shock, d_A^c for firm A is independent of his location shock for B . l_{j_i} is the location of firm j ’s i^{th} product

³ In a two-stage environment where firms first choose product concentrations and then prices, our results would take on the flavor of quality competition: ex-ante symmetric firms would prefer asymmetric concentrations. This is similar to a result derived by Champsaur and Rochet (1989) that in an environment where each firm offers a set of vertically differentiated products and then competes on prices, firms maximally differentiate on quality. Similar considerations emerge in Bernhardt, Liu, and Serfes (2007).

associated dis-utility from not consuming at one’s most preferred point in the characteristic space or geographical differentiation. The location shocks are easiest to interpret in characteristic space: for example, a consumer may prefer Diet Coke to Sprite, i.e. be closer to Diet Coke than to Sprite in characteristic space, but be equally likely to prefer Pepsi or Diet Pepsi.

We define $\delta_j^c(S_j, S_{-j})$ to be an indicator function that takes on the value 1 if consumer c purchases from a firm j product line and is 0 otherwise. Consumer c maximizes utility when

$$\delta_j^c(S_j, S_{-j}) = \begin{cases} 1 & \text{if } \min_{i \in N_j} \{p_{j_i} + T|l_{j_i} - d_j^c|\} < \min_{i \in N_{-j}} \{p_{-j_i} + T|l_{-j_i} - d_j^c|\} \\ 0 & \text{if } \min_{i \in N_j} \{p_{j_i} + T|l_{j_i} - d_j^c|\} > \min_{i \in N_{-j}} \{p_{-j_i} + T|l_{-j_i} - d_j^c|\}, \end{cases}$$

where d_j^c is consumer c ’s location shock for firm j .

Given franchise profiles (S_A, S_B) , let $y_{j_i}(d_j, S_A, S_B)$ be the conditional probability from the perspective of firm j (i.e. integrating over d_{-j}) that a consumer with location shock d_j purchases product j_i and (integrating over d_j) let $Y_{j_i}(S_A, S_B)$ be the expected measure of consumers who purchase product j_i . Explicit solutions for $y_{j_i}(d_j, S_A, S_B)$ and $Y_{j_i}(S_A, S_B)$ are in the Appendix. Then firm j ’s profits are

$$\pi_j(S_A, S_B) = \sum_{i=1}^{n_j} p_{j_i} Y_{j_i}(S_A, S_B) - n_j F, \quad j \in \{A, B\}.$$

2.1 Equilibrium

An equilibrium is a collection of (i) product line profiles, $S_j^* = [n_j^*, \{l_{j_i}^*, p_{j_i}^*\}_{i=1}^{n_j}]$, $j \in \{A, B\}$, and (ii) a set of demand functions for each consumer c , $\delta_j^{c*}(S_A, S_B)$, such that

- Product line profiles maximize profit $\pi_j(S_j^*, S_{-j}^*) \geq \pi_j(\hat{S}_j, S_{-j}^*) \forall \hat{S}_j \in \Sigma_j$, $j \in \{A, B\}$ given the subsequent optimization by almost all consumers.

We first characterize how a firm’s own products compete with each other for consumers. To do this, we develop the notion of product j_i ’s *service area* – the set of optimizing consumers who, if they purchase from firm j , will purchase product j_i . In any equilibrium, each of firm j ’s products must be purchased by some customers (else the costly product ought not be developed); however, among consumers who purchase from firm j , only those who are sufficiently nearby product j_i will purchase it. Accordingly, we let $a_{j_{i+1}}(S_j)$ be the identity of the consumer who is indifferent between purchasing product j_i and j_{i+1} from firm j :

$$a_{j_{i+1}}(S_j) = \frac{p_{j_{i+1}} - p_{j_i}}{2T} + \frac{l_{j_{i+1}} + l_{j_i}}{2}, \quad \forall i \in N_j, \quad j \in \{A, B\},$$

where $l_{j_i} = 0$ and $l_{j_{n_j+1}} = 1$ (the position of the first product from the viewpoint of the last product). Any optimizing consumer located outside of $[a_{j_{i-1,i}}(S_j), a_{j_{i+1,i}}(S_j)]$ who purchases from firm j can derive a higher payoff by purchasing a firm j product other than j_i (in particular, purchasing either product j_{i+1} or j_{i-1}).

Definition 1 Product j_i is **isolated** if

$$y_{j_i}(a_{j_{i-1,i}}(S_j), S_A, S_B) = y_{j_i}(a_{j_{i+1,i}}(S_j), S_A, S_B) = 0.$$

Definition 2 Product j_i is **connected** if

$$\min\{y_{j_i}(a_{j_{i-1,i}}(S_j), S_A, S_B), y_{j_i}(a_{j_{i+1,i}}(S_j), S_A, S_B)\} > 0.$$

Product j_i is isolated if it does not compete for market share against other firm j products. In particular, if product j_i is isolated, then an individual located at $a_{j_{i-1,i}}(S_j)$, who is indifferent between purchasing product j_i and j_{i-1} , prefers with probability one to purchase from the rival firm. If a firm's product is isolated, then the product only competes for customers against the rival firm, and not against each other. In contrast, product j_i is connected if, in addition to competing against the rival firm, it competes for customers with an adjacent product, j_{i-1} or j_{i+1} . That is, product j_i is connected if there is a strictly positive probability that a consumer who is indifferent between purchasing j_i and a neighboring product strictly prefers those alternatives to purchasing *any* of the rival's products. We first establish an important result for how a firm's products compete against each other.

Lemma 1 In firm j 's best response, either all of its products are isolated or all of its products are connected.

The intuition for this result is that a firm with a mix of isolated and connected products could earn higher profits by bringing its isolated products marginally closer together and spreading its other products marginally further apart, while keeping its prices fixed. Bringing isolated products marginally closer does not affect their market shares because these products do not compete against each other for customers; but the market shares of the remaining products grow because their service areas increase. Thus, the firm's profit increases, implying that a mix of isolated and connected products cannot be optimal.⁴

⁴ Uniformity of consumers over the circle is important since the mass of consumers served only depends on the relative locations of the products to each other, not on their absolute location. However, the result would continue to hold as long as the distribution function of consumers over the circle is sufficiently smooth.

Lemmas 2 and 3 characterize the implications of Lemma 1 for pricing and location.

Lemma 2 *Suppose firm j 's best response to S_{-j} has only isolated products. Then firm j 's best response features identical pricing of each product and equal market shares.*

If each firm j product is isolated, then each has the same demand. Therefore, charging the same price for each product, and capturing the same market share, is a best response.

Now consider a firm with connected products. The analogous result to Lemma 2 is that this firm does best to space its products equally, and set the same price for each product. To establish this we first show that equal spacing and identical pricing solves the firm's first-order conditions for profit maximization; an exhaustive numerical analysis then indicates that this strategy is the unique best response.

Lemma 3 *Suppose firm j 's best response to S_{-j} has only connected products. Then firm j 's best response spaces products at equal distances and sets identical prices.*

These lemmas reveal that our model is consistent with key empirical features of the data. In particular, an optimizing firm sets the same price for each of its products, regardless of the structure of the competing firm's product network. Of course, the optimal *level* of this price reflects the competing network. A corollary is that without loss of generality, we can restrict attention to strategies that feature product line profiles with uniform pricing and equidistant product spacing, and consider demand for a representative firm j product. We now do this, treating the number of products as a continuous variable and focusing on a firm's choice of product concentration. Because we now focus on a representative firm j product, we use d_j^c to measure the distance of consumer c from a firm j product.

3 Continuous model

3.1 Symmetric duopoly

Without loss of generality, we can assume that $p_A \geq p_B$. We first prove that if $p_A \geq p_B$, then, in equilibrium, firm B 's products are isolated, competing only for

the market share from firm *A* products, and not cannibalizing market share from its own product line. In turn, this will imply that firm *B* cannot earn positive profits.

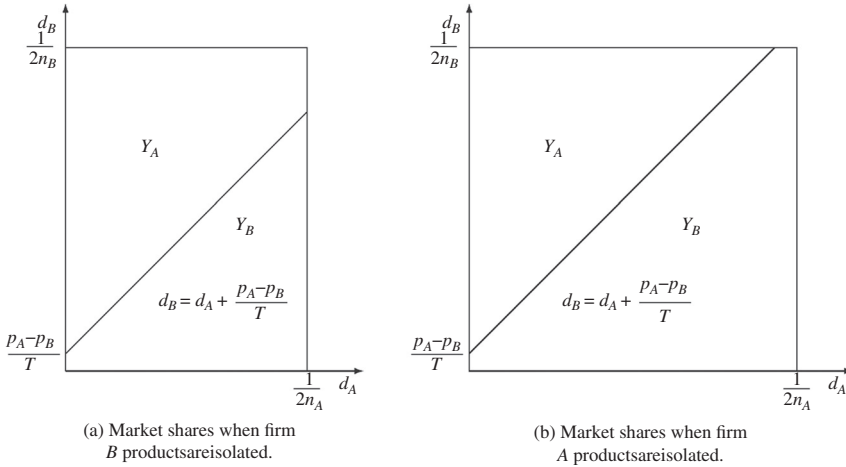

Figure 2: Market shares when $p_A \geq p_B$. Area Y_j denotes the expected market share for firm j . The density of the area is $4n_A n_B$

Figure 2 illustrates the market shares captured by each firm under the two possible scenarios (under the maintained assumption that $p_A \geq p_B$ in equilibrium). In each graph, area Y_j captures firm j 's expected market share and from the firms' perspectives, consumers are uniformly distributed over the graph with a density of $4n_A n_B$. Consider a consumer c who receives a location shock pair that puts him on the edge of each of the representative product's service areas, i.e. $(d_A^c, d_B^c) = (1/(2n_A), 1/(2n_B))$. Figure 2(a) illustrates the case where

$$\frac{1}{2n_B} > \frac{p_A - p_B}{T} + \frac{1}{2n_A}. \tag{1}$$

Then this marginal consumer prefers to purchase from firm *A*, implying that firm *B* products are isolated. Figure 2(b) illustrates the other possibility, i.e. where

$$\frac{1}{2n_B} < \frac{p_A - p_B}{T} + \frac{1}{2n_A}. \tag{2}$$

Then the marginal consumer prefers to purchase from firm *B*, implying that the firm *A* products are isolated. Hence, if firm *B* products are isolated, i.e. if inequality [1] holds, then

$$\begin{aligned}
 Y_A &= 4n_A n_B \int_0^{\frac{1}{2n_A}} \int_{d_A + \frac{p_A - p_B}{T}}^{\frac{1}{2n_B}} 1 dd_B dd_A \\
 &= 1 - \frac{n_B}{2n_A} - 2n_B \frac{p_A - p_B}{T}, \text{ and} \tag{3}
 \end{aligned}$$

$$Y_B = 1 - Y_A = \frac{n_B}{2n_A} + 2n_B \frac{p_A - p_B}{T}. \tag{4}$$

If, instead, firm A products are isolated, i.e. if eq. [2] holds, then

$$\begin{aligned}
 Y_A &= 4n_A n_B \int_0^{\frac{1}{2n_B}} \int_{d_A + \frac{p_A - p_B}{T}}^{\frac{1}{2n_B}} 1 dd_B dd_A \\
 &= \frac{n_A}{2n_B} \left(1 - 2n_B \frac{p_A - p_B}{T} \right)^2 \tag{5}
 \end{aligned}$$

$$Y_B = 1 - Y_A = 1 - \frac{n_A}{2n_B} \left(1 - 2n_B \frac{p_A - p_B}{T} \right)^2. \tag{6}$$

Lemma 4 below shows that if $p_A^* \geq p_B^*$, then, in equilibrium, we can restrict attention to an environment where firm B products are isolated, the case illustrated in Figure 2(a).

Lemma 4 *If $p_A^* \geq p_B^*$ then $Y_A^* \geq Y_B^*$ and firm B products are isolated in equilibrium.*

The intuition is that the marginal reduction in a firm’s market share due to raising its price is the same for both firms. To see this, let $p_d = p_A - p_B$. Then

$$\frac{\partial Y_A}{\partial p_A} = \frac{\partial Y_A}{\partial p_d} = \frac{\partial(1 - Y_B)}{\partial p_d} = -\frac{\partial Y_B}{\partial p_d} = \frac{\partial Y_B}{\partial p_B}.$$

The first-order conditions for profit maximization of each firm with respect to price gives

$$Y_A^* = -p_A^* \frac{\partial Y_A^*}{\partial p_A^*} \text{ and } Y_B^* = -p_B^* \frac{\partial Y_B^*}{\partial p_B^*}.$$

Substituting for $\frac{\partial Y_A}{\partial p_A} = \frac{\partial Y_B}{\partial p_B}$ yields

$$\frac{Y_A^*}{Y_B^*} = \frac{p_A^*}{p_B^*}.$$

Therefore, $p_A^* \geq p_B^*$ implies $Y_A^* \geq Y_B^*$. The proof reveals that a necessary condition for this is that the extreme consumer, i.e. the consumer located $\frac{1}{2n_A}$ from product

A and $\frac{1}{2n_B}$ from product B , purchases from firm A ; that is, firm B has isolated products.

We now derive the consequences for equilibrium firm profits.

Proposition 1 *In the unique equilibrium, the two firms earn zero profits, the product concentration for both firms is $n_j^* = \frac{1}{2} \sqrt{\frac{T}{2F}}$ and the price set at each product is $p_j^* = \sqrt{\frac{FT}{2}}$.*

To understand why firms earn zero profits, first consider the weakly smaller firm B that charges $p_B \leq p_A$. Suppose its profit is positive. From Lemma 4, B 's products must be isolated, so when B increases its product concentration marginally, B only attracts customers away from firm A , and *not* from its own established products. Since customers served per product is constant, if average profit per product is positive, B 's profit must rise linearly with the number of its products, exhibiting “constant returns to scale” over the range where its products are isolated. But then B could increase profits by increasing its product concentration, a contradiction of the premise that it is an equilibrium.

Next suppose the larger firm A earns strictly positive profits. But then if B set $p_B = p_A^*$, it must generate strictly positive profits, because its market share per product strictly exceeds A 's. But this is a contradiction, as we showed that the smaller firm earns zero profit.

Lastly, consider the possibility of a symmetric equilibrium in which firms earn strictly positive profits. But then each firm has an incentive to increase product concentration marginally: The within-firm cannibalization of market share from its other products due to increasing product concentration slightly is arbitrarily small and second order, whereas the “new product” gains a market share and profit that is first order. That is, a firm's products are “almost” isolated. It follows that firms compete away all profits: in equilibrium, firms fail to exploit the ex-post heterogeneity in consumers that lead them to prefer one firm's product to another's. Even though firms earn positive gross (of product development costs) profits due to this heterogeneity, in equilibrium, the cost of developing products offsets these profits. One can show that this zero-profit outcomes extends to a setting with $N > 2$ identical firms.

The constant returns to scale in franchise establishment underlie the stark result of zero firm profit. However, the qualitative result extends: with diseconomies of scale in product establishment, firms would still equate the *marginal* cost of a establishing an additional product with the *average* profit of each product. Thus, any firm profit in such an environment would only come from the equilibrium difference between marginal and average product establishment costs. We next establish the robustness of these results in other dimensions.

3.2 Asymmetric costs and preferences

We now relax the symmetrical properties of the economic environment to allow for

1. Firm-specific heterogeneity in costs of establishing products, $F_A \neq F_B$, or marginal costs of production, $c_i \geq 0$.
2. Consumers with preferences for one firm's product: consumers derive a common utility $V + a$ from firm A 's product and V from firm B , where a could be positive or negative.

Proposition 2 *At least one firm earns zero profit in equilibrium.*

To expand on this result, suppose that firm B is a clearly identifiable *disadvantaged* firm:

Proposition 3 *If $F_B \geq F_A$, $c_B \geq c_A = 0$, and $a \geq 0$, with one inequality strict, then in the unique equilibrium*

- Disadvantaged firm B earns zero profits and advantaged firm A earns positive profits,
- Disadvantaged firm B sets a lower price: $p_B^* = \sqrt{\frac{F_B T}{2}} + c_B < p_A^* - a$.

In equilibrium, the disadvantaged firm's products are isolated. This implies that the disadvantaged firm scales up product concentration to the point where its profits are zero, setting the price given in Proposition 3. The advantaged firm exploits its preferred product and/or better technology to earn positive profits. A numerical analysis verifies the expected comparative statics: firm A 's profits rise with a , c_B , and F_B , but fall with F_A . More interestingly, A 's profits fall with T : the reduction in price competition due to increased travel costs is more than offset by the increase in product provision.

3.3 Social planner

We now compare equilibrium outcomes with the solution to a social planner's problem, in which the social planner maximizes total (consumer plus producer) surplus by choosing product concentration; and then firms compete for customers by setting price. Because the equilibrium features symmetric firm product concentrations, to make comparisons meaningful, we limit the social planner to symmetric firm product concentrations.⁵ Because V is large enough that all

⁵ Without this assumption we would need to consider the welfare associated with one firm, which would necessarily imply an uncovered market.

consumers purchase in equilibrium, prices just transfer surplus from consumers to firms, and hence do not affect total social surplus. It follows that the social planner seeks to minimize the sum of travel and product development costs,

$$4n_A n_B \int_0^{\frac{1}{2n_A}} \left(\int_0^{d_A + \frac{p_A - p_B}{t}} T d_B d d_B + \int_{d_A + \frac{p_A - p_B}{t}}^{\frac{1}{2n_B}} T d_A d d_B \right) d d_A + F(n_A + n_B).$$

Proposition 4 *The equilibrium product concentration exceeds the social optimum.*

It follows from Proposition 4 that at the social optimum, firms earn strictly positive profits. Intuitively, the equilibrium over-provision of products results from the efforts of firms to compete for greater market share. A social planner internalizes this externality: the social planner does not care about the market share of individual firms, but firms do.

4 Additional taste heterogeneity

We now investigate how outcomes are affected when, in addition to the endogenous contestable spatial consumer heterogeneity, consumers also differ exogenously in their intrinsic taste for each firm's product. For example, some consumers may like Coca Cola's soda more than PepsiCo's, while others may have the opposite preference. So, too, some consumers may prefer the marketing or branding by one firm (e.g. Nike's swoosh) that is common to that firm's product line, while other consumers prefer a rival's branding.

Specifically, we suppose that in the population of consumers, the relative valuation z of firm A is uniformly distributed on $[-m, m]$, where $m > 0$. A consumer with relative valuation z gains an additional value (in dollar terms) of $z/2$ from purchasing firm A 's good and loses $z/2$ from purchasing firm B 's good. Thus, consumers differ due to both (i) the endogenous spatial distance between a consumer's location and a firm's product locations and (ii) the heterogeneity in their relative tastes for firm A 's products. The magnitude of m captures the importance of exogenous taste heterogeneity relative to endogenous spatial heterogeneity.

Now when consumers make their purchases they consider their relative preferences (or dispreferences) for firm A : for almost every consumer, $\delta_B^c(z, S_A, S_B) = 1$ if and only if

$$V + \frac{z}{2} - p_A - T d_A^c \geq V - \frac{z}{2} - p_B - T d_B^c.$$

Ex ante, the probability a consumer shops at a firm A product is $\text{Prob}(d_A^c - d_B^c - \frac{z}{T} \leq \frac{p_B - p_A}{T})$.

Proposition 5 *In the symmetric equilibrium, firms earn strictly positive profits when consumer tastes are heterogeneous. Equilibrium product concentration is*

always $n^ = \frac{1}{2} \sqrt{\frac{T}{2F}}$ regardless of the extent of taste heterogeneity.*

- *If taste heterogeneity is small, $m \leq \sqrt{2FT}$, the equilibrium price is $p^* = \frac{2FT}{\sqrt{8FT-m}}$ and firm profit is $\pi^* = \frac{m\sqrt{2FT}}{4(\sqrt{8FT-m})}$.*
- *If taste heterogeneity is larger, $m > \sqrt{2FT}$, the equilibrium price is $p^* = m$ and firm profit is $\pi^* = \frac{1}{2} \left(m - \sqrt{\frac{FT}{2}} \right)$.*

The equilibrium product concentration does not depend on whether consumers have heterogeneous tastes. While increased taste heterogeneity leads to higher equilibrium prices and thus to greater incentives to increase product concentrations (given positive firm profit), this is exactly offset by the incentives to reduce concentration resulting from increased consumer sensitivity to exogenous taste heterogeneity relative to endogenous spatial heterogeneity.

Why then do firms now earn strictly positive profits? The answer is that a consumer located on the extreme of a firm j service area, i.e. $d_j^c = 1/(2n)$, now prefers to purchase from firm j with *strictly* positive probability, as the consumer may have a large relative taste preference for firm j . Unlike in the base model, products are no longer isolated. Hence, were firm j to increase its product concentration, it would now steal consumers from its other products. Heterogeneous tastes create ‘decreasing net returns to scale’ in product concentrations. As a result, a firm’s incentive to increase concentration falls, and with weakened product competition, firms earn strictly positive profits in equilibrium.

The comparative statics on F and m are natural. Profits rise with increased taste heterogeneity m . The higher equilibrium prices are not offset by any increase in firm concentrations. Profits decrease with increased product establishment costs F . The direct effect of increased costs is only partially offset by reduced product concentration and increased prices.

More interesting are the comparative statics on T . We use these to show how introducing a contestable spatial dimension affects firm profits relative to an economy where consumer only differ on an exogenous taste dimension. In particular, when $T = 0$, firm profits just equal the equilibrium profits firms would receive if tastes only differed on this exogenous dimension. One might conjecture that adding endogenous spatial heterogeneity would not alter firm profits, especially since equilibrium product concentration is unaffected by the extent of consumer heterogeneity in tastes. This conjecture is false:

Proposition 6 *Equilibrium firm profits fall monotonically with travel costs when there is both exogenous taste heterogeneity and contestable consumer spatial heterogeneity.*

As T rises, consumers become more sensitive to spatial heterogeneity. As a result, each firm has an incentive to unilaterally increase product concentration, regardless of price. When T is small relative to the extent of taste heterogeneity so that $T < m^2/(2F)$, the equilibrium price is completely insensitive to the endogenous spatial dimension, i.e. the equilibrium price does not vary with T or F . When T is small, some of the consumers located at distances (d_A^c, d_B^c) from the closest respective products will purchase from A and some from B . That is, consumers are never located so far from one firm's product and so close to the other that spatial considerations swamp taste preferences for all consumers at the location. Thus, the impact on firm demand from a unilateral marginal increase in price is determined solely by the density of consumers in the exogenous taste dimension. The consequence is stark – price in the economy without the endogenous spatial dimension is the same as that when the spatial dimension is present. It follows that for small T , the firms extract no benefits from the products that they establish: all product development costs are completely wasted.

When transportation costs are greater relative to the extent of taste heterogeneity so that $T > m^2/(2F)$, some consumers will be located close enough to one firm's product, and far enough from its rival's product, that they will purchase from the closer firm regardless of their tastes for one firm's product. As a result, pricing becomes sensitive to product concentration and some product development costs are now recovered; however, profits still decline as transportation costs rise. In the limit, as $\frac{T}{m^2}$ grows arbitrarily large, spatial heterogeneity causes firms to compete away three-quarters of the potential marginal value of the taste heterogeneity, m . Thus, in the (slightly abused) language of Cabral and Villas-Boas (2005), spatial heterogeneity can be viewed as a Bertrand trap. The direct effect of increased spatial heterogeneity on firm profits is zero, but the indirect effect through the strategic response, particularly increased product concentration, reduces firm profit.

5 Multi-product line competition

We now introduce multiple product lines for each firm, allowing for both meaningful correlation in consumer preferences across product lines and for differences in the costs of creating products across product lines. Concretely, we let a preference for Diet Coke reveal a likely preference for soda drinks over fruit

juices, and sodas can be less expensive to provide, but we maintain the assumption that a preference for Diet Coke over Coke reveals nothing about preferences for Diet Pepsi vs. Pepsi. So, too, a preference for a Honda Odyssey may suggest a likely preference for vans, but a consumer's preferred Toyota could turn out to be a Camry.

To model multiple product lines, we assume that firms A and B have products associated with two spatial circles, each of unit length. Each consumer is located on one spatial circle for each firm. The cost of traveling distance d on a circle is Td , and the disutility costs between a firm's circles are "high enough" that in equilibrium a consumer always purchases a product on one of the circles on which he or she is located. The unconditional probability that a consumer is located on a circle i is one-half, $i = 1, 2$. We introduce correlation in preferences over products by supposing that if a consumer is located on circle i of firm A , then the conditional probability that the consumer is located on circle i for firm B is λ (and vice versa for a consumer located on circle i for firm B).⁶ We introduce heterogeneity between product lines by assuming that the cost F_1 of introducing a product variety on circle 1 exceeds the cost F_2 of a product variety on circle 2, i.e. $F_1 > F_2$. Introducing heterogeneity along other dimensions (e.g. spatial distances) gives rise to analogous results; and relaxing the assumption that, ex ante, a consumer is equally likely to be on each circle is routine. We renormalize the measure of consumers to two.

The total profit function for firm $j = A, B$ becomes

$$\pi_j = p_{j_1}(\lambda Y_{j_{11}} + (1 - \lambda)Y_{j_{12}}) + p_{j_2}(\lambda Y_{j_{22}} + (1 - \lambda)Y_{j_{21}}) - (F_1 n_{j_1} + F_2 n_{j_2}),$$

where, for example, $Y_{A_{ik}}$ denotes the measure of consumers who purchase from firm A when they are located on circle i of firm A and circle k of firm B , $i, k = 1, 2$, and we omit the dependence of these measures on prices and numbers of products.

Proposition 7 *In the unique symmetric equilibrium, firms earn zero profits from their high cost product line, but strictly positive profits of at least*

⁶ Reisinger (2006) studies product bundling in a duopolistic multi-product environment with an ostensibly similar preference structure. His model features two products x_1 and x_2 , each with their own spatial circle, both produced by two firms A and B , where firm A is located at 0 on both circles, while B is located directly opposite at $1/2$. A consumer located at x_1 on circle 1 is located on $x_1 + \delta$ on circle 2, where δ is a parameter that provides a measure of how many consumers are most likely to prefer both of one firm's products. Thus, although his set up has a multi-product feature to address strategic bundling, Reisinger's model has more in common with standard spatial models than with ours: in his model, firm locations are exogenous, and given knowledge about a consumer's preference for firm A 's first product, one can *exactly* determine the consumer's preference for all other products.

$(1 - \lambda)p_2 \left(Y_{21} - \frac{n_1}{2n_2} \right) > 0$ from their low cost product line, as long as $\lambda \in [0, 1)$. Firms stock their low cost line more extensively: $n_2 > n_1$. Firms set a higher price for their high cost product line, i.e. $p_1 > p_2$, if and only if $\lambda > \lambda^*$, where $\lambda^* = \frac{\sqrt{F_2} \sqrt{8F_1 + F_2} - 3F_2}{2(F_1 - F_2)} \in (0, \frac{2}{3})$, and at λ^* , $\frac{n_2}{n_1} = \frac{F_1}{F_2}$.

Intuition for this proposition can be gleaned by considering the extreme scenarios of perfectly positive and negative correlation in consumer preferences, i.e. $\lambda = 1$ and $\lambda = 0$. When $\lambda = 1$, a consumer on firm A’s circle 1 is also on circle 1 of firm B; and when $\lambda = 0$, a consumer on firm A’s circle 1 is on firm B’s circle 2. When $\lambda = 1$, firm j’s profits become

$$\sum_{k=1}^2 p_{jk} Y_{jkk} - F_k n_{jk}.$$

The separability of the profit function across product lines immediately implies that equilibrium is characterized by Proposition 1: the firms compete against each other on a circle-by-circle basis, setting prices $p_k = \sqrt{\frac{TF_k}{2}}$, earning zero profits. Further, $F_1 > F_2$ implies that firms introduce fewer varieties of their costlier product, $n_1 < n_2$, and this means that there is less competition, ex-post, between the costlier products, so that firms charge higher prices for the **more costly** to introduce products, i.e. $p_1 > p_2$.

Conversely, when $\lambda = 0$, a consumer who is on firm A’s circle 2 is on firm B’s circle 1, where products are more expensive to introduce. Again profit functions are separable, with each firm having an advantaged circle 2 competing against its rival’s disadvantage circle 1, and a disadvantaged circle 1 competing against its rival’s advantaged circle 2. Therefore, equilibrium is characterized by Proposition 3, with firms earning zero expected profits from their disadvantaged circle 1, setting price $p_1 = \sqrt{\frac{TF_1}{2}}$ and earning strictly positive profits from their advantaged circle 2, now charging higher prices for the **less costly** to introduce products, i.e. $p_2 > p_1$, as firm exploit their more extensive product line. That is, firms internalize that because $n_2 > n_1$, more consumers will be closer to a type 2 product than a type 1 product – on average, consumers will prefer a type 2 product to a type 1 product – and the firms exploit this in their pricing.

The proof shows that these qualitative results extend to intermediate correlations, $\lambda \in (0, 1)$. Which type of product is priced higher depends on how likely high-cost products are to compete against high-cost products rather than low-cost products. If $\lambda > \lambda^*$, then one firm’s high-cost product is sufficiently likely to compete against the other firm’s high-cost product that $\frac{F_1}{F_2} > \frac{n_2}{n_1}$, and hence the high-cost product has a higher price, $p_1 > p_2$. If, instead, $\lambda < \lambda^*$, then $\frac{F_1}{F_2} < \frac{n_2}{n_1}$, and

hence the likely preference for the more available good 2 dominates in pricing, i.e. $p_2 > p_1$.

The intuition for why firms earn profits reflects that the cost differences induce firms to provide more products on their less costly lines. Some consumers are located on one firm's less costly product line, but the rival's costly product line. Because the less costly product line is more extensively stocked, i.e. $n_2 > n_1$, it competes against itself for some consumers – some consumers strictly prefer more than one product on one firm's less costly line to any of the rival's products. Firms internalize this own product line competition reducing the extent to which they expand their less costly product lines. This reduces the intensity of price competition, allowing firms to extract strictly positive profits.

The analysis makes clear that profits vanish when the correlation in preferences is high, i.e. when $\lambda \rightarrow 1$, or when cost heterogeneity is modest, i.e. when $F_1 \rightarrow F_2$. What is less clear is how intermediate levels of correlation affect profits when cost heterogeneity is nontrivial.

To provide insight into the qualitative effects of intermediate levels of correlations in preferences across product lines, Figure 3 graphs how λ affects equilibrium profits and $\frac{n_2}{n_1}$ when $F_1 = 1$ and $F_2 = \frac{1}{2}$, so that products on circle 1 are twice as expensive to produce, and T is normalized to 10,000. As λ is reduced below 1, profits initially increase sharply (convexly) from zero, but then the rate of increase slows down, and profits are maximized when $\lambda \sim 0.126$. In particular, maximizing the probability $1 - \lambda$ that less costly products compete against a rival's costlier products does *not* maximize firm profits. The direct effect on profits of reducing λ is always positive. However, at $\lambda \sim 0.39$, n_1 reaches

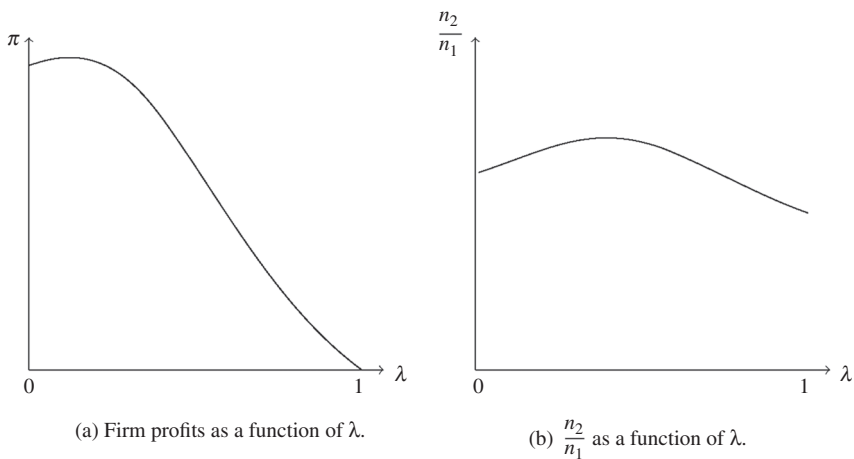

Figure 3: Firm profits and product ratios. Parameters: $F_1 = 1$, $F_2 = \frac{1}{2}$, $T = 10000$

a minimum and n_2 reaches a maximum, implying that $\frac{n_2}{n_1}$ begins to fall as λ is reduced further below 0.39. The intuition is that as λ falls, a firm's less costly product line increasingly competes against itself for customers who are located on its rival's costlier line. This increased own-product line competition eventually causes firms to reduce n_2 . Once λ falls below 0.126, the decrease in $\frac{n_2}{n_1}$ swamps the direct increase in $(1 - \lambda)$, and profits begin to fall.

Figure 4 shows that greater heterogeneity in product development costs (a) sharply raise firm profits and $\frac{n_2}{n_1}$ and (b) magnify the single-peaked relationship with λ . The economics underlying these patterns is the same – as λ falls, a firm's low cost line increasingly competes against itself for customers on the rival's high cost line, eventually causing $\frac{n_2}{n_1}$ and then profits to fall. Quite generally, the qualitative property that firm profits and $\frac{n_2}{n_1}$ are single peaked functions of λ is robust. However, it is also important to note that these peaks occur at low values of λ , and plausible parameterizations would seem to be where a consumer who prefers one firm's soda to its juices is more likely to prefer the rival's sodas to its juices. This suggests that for plausible parameterizations, both $\frac{n_2}{n_1}$ and firm profits rise as λ is reduced, i.e. as less costly-to-produce products become more likely to compete against costlier ones.

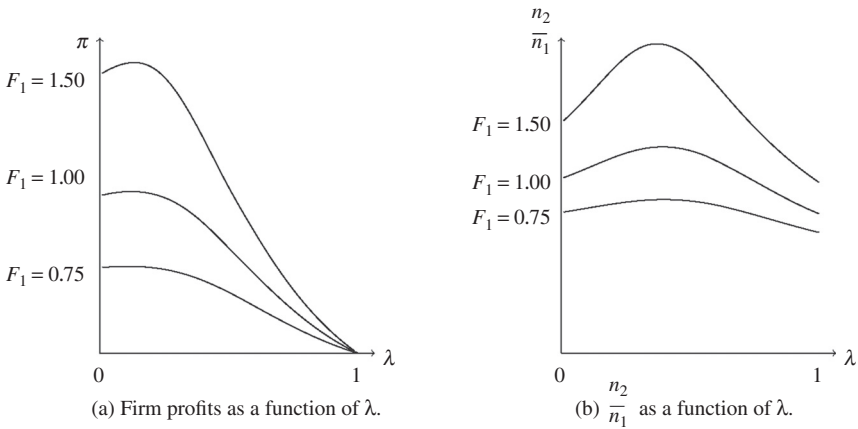

Figure 4: Firm profits and product ratios. Parameters: $F_2 = \frac{1}{2}$, $T = 10000$

6 Conclusion

We develop a novel spatial model in which consumers receive *firm-specific* location shocks. We endogenize both firm pricing and product/franchise

locations, establishing a stark result: when the sole source of heterogeneity is the endogenous spatial heterogeneity, firms earn zero profits in equilibrium. That is, while the ex-post endogenous consumer heterogeneity that firms create ensures positive gross profits, competition for market share via greater product provision drives net profits down to zero. This qualitative result extends when firms differ in product creation costs or a firm has a better product: the “disadvantaged” firm earns zero net profits. The equilibrium level of product provision is socially excessive – a social planner internalizes the competition for market share and chooses a lesser concentration. It follows that in equilibrium, firm compete profits below those associated with the social optimum.

We then introduce additional exogenous heterogeneity in consumer tastes. Firms profit from this exogenous taste heterogeneity. However, the contestable spatial dimension interacts with the heterogeneity in tastes, enhancing price competition, actually causing firms to compete profits *below* those that would obtain without the endogenous spatial heterogeneity.

Our model remains tractable even in the presence of significant heterogeneity across aspects of firms. As such, our model can be used as the foundation for the analysis of competition between networks in other settings. In particular, we can analyze competition between firms with multiple product lines, where a preference for a good from one firm’s product line contains information about likely preferences over a rival’s product lines. Concretely, a preference for Coke can convey a likely preference for sodas over juices. When we introduce such correlation in consumer preferences and integrate the possibility that some products are more costly to produce, we find that firms earn strictly positive profits as long as preferences are not perfectly positively correlated. In this situation, sometimes a firm’s inexpensive product line competes against itself for some consumers, rather than against the rival’s expensive product line; this reduces the incentives to over-provide products, reducing the intensity of price competition, and allowing firms to earn strictly positive profits.

Appendix: Proofs

Calculating $y_j(d_j, S_A, S_B)$: Define

$$\underline{a}_j(S_j) = \min\{l_j - a_{j-1,i}(S_j), a_{j,i+1}(S_j) - l_j\},$$

$$\bar{a}_j(S_j) = \max\{l_j - a_{j-1,i}(S_j), a_{j,i+1}(S_j) - l_j\},$$

for $i \in N_j$, $j \in \{A, B\}$. $\underline{a}_j(S_j)$ and $\bar{a}_j(S_j)$ are the shortest and longest distances from product j_i ’s i location to the edge of their service area.

Given strategies (S_A, S_B) and location shock d_j in product j_i 's service area, the conditional expected demand $y_{j_i}(d_j, S_A, S_B)$ is the measure of firm $-j$'s circle for which the total delivery cost of the product is lower if purchased from product j_i than from the lowest competing alternative. Let $a_{-j_k}^i(d_j, S_A, S_B)$ represent the distance from l_{-j_k} at which a consumer with location shock d_j is indifferent between purchasing product j_i and product $-j_k$, i.e.

$$a_{-j_k}^i(d_j, S_A, S_B) = \frac{p_{j_i} - p_{-j_k}}{T} + |d_j - l_{j_i}|$$

We partition N_{-j} into four sets by comparing this distance to the length of each product $-j_k$'s service area.

$$L_j(d_j, S_A, S_B) = \{k \in N_{-j} : a_{-j_k}^i(d_j, S_A, S_B) > \bar{a}_{-j_k}(S_{-j})\},$$

$$M_j(d_j, S_A, S_B) = \{k \in N_{-j} : \underline{a}_{-j_k}(S_{-j}) < a_{-j_k}^i(d_j, S_A, S_B) \leq \bar{a}_{-j_k}(S_{-j})\},$$

$$H_j(d_j, S_A, S_B) = \{k \in N_{-j} : 0 < a_{-j_k}^i(d_j, S_A, S_B) \leq \underline{a}_{-j_k}(S_{-j})\},$$

$$V_j(d_j, S_A, S_B) = \{k \in N_{-j} : a_{-j_k}^i(d_j, S_A, S_B) \leq 0\}.$$

Total delivery cost of product $-j_k \in L_j(d_j, S_A, S_B)$ to any point in its service area is lower than total delivery cost of product j_i to d_j . Total delivery cost of $-j_k \in V_j(d_j, S_A, S_B)$ to any point in its service area is higher than the total delivery cost of product j_i to d_j . The remaining $-j_k$ products "split" their service area. For distances close to l_{-j_k} total delivery cost of $-j_k$ is lower than product j_i to d_j , while for distances far away, the total delivery cost of $-j_k$ is higher than product j_i to d_j . We use this notation to calculate $y_{j_i}(d_A, S_A, S_B)$:

$$y_{j_i}(d_j, S_A, S_B) = \min\{0, 1 - \sum_{k \in H_j} 2a_{-j_k}^i(d_j, S_A, S_B) - \sum_{k \in M_j} a_{-j_k}^i(d_j, S_A, S_B) + \underline{a}_{-j_i}(S_{-j}) - \sum_{k \in L_j} \underline{a}_{-j_k}(S_{-j}) + \bar{a}_{-j_k}(S_{-j})\}.$$

Calculating $Y_{j_i}(S_A, S_B)$: By definition,

$$Y_{j_i}(S_A, S_B) = \int_{a_{j_i-1,i}(S_j)}^{a_{j_i+1}(S_j)} y_{j_i}(d_j, S_A, S_B) dd_j.$$

To prove some results we use a more explicit decomposition of $Y_{j_i}(S_A, S_B)$ that exploits the fact that $Y_{j_i}(S_A, S_B)$ is the sum of trapezoids. Define

$$A_{j_i} = \{0 \leq a \leq \bar{a}_{j_i}(S_j) : a \in \cup_{k \in N-j} \{a_{j_i}^{-j_k}(l_{-j_k}, S_A, S_B), a_{j_i}^{-j_k}(a_{-j_{k,k+1}}, S_A, S_B)\}\} \cup \{0, \underline{a}_{j_i}(S_j), \bar{a}_{j_i}(S_j)\}.$$

The first set that defines A_{j_i} are the distances from l_{j_i} within franchise j_i 's service area at which a consumer located at either l_{-j_k} or $a_{-j_{k,k+1}}$ is indifferent between purchasing product j_i or $-j_k$. Let $\bar{k}_{j_i} = |A_{j_i}|$ and $\underline{k}_{j_i} = |\{a \in A_{j_i} : a \leq \underline{a}_{j_i}(S_j)\}|$ and order the elements of A_{j_i} from 1 to \bar{k}_{j_i} so that $a_k \leq a_{k+1}$.

$$Y_{j_i}(S_A, S_B) = \sum_{k=1}^{\bar{k}_{j_i}-1} 2T(a_k, a_{k+1}, y_{j_i}(l_{j_i} + a_k, S_A, S_B), y_{j_i}(l_{j_i} + a_{k+1}, S_A, S_B)) + \sum_{k=\underline{k}_{j_i}}^{\bar{k}_{j_i}-1} T(a_k, a_{k+1}, y_{j_i}(l_{j_i} + a_k, S_A, S_B), y_{j_i}(l_{j_i} + a_{k+1}, S_A, S_B)) \quad [7]$$

where $T(a, b, c, d) = (a - b)(c + d)/2$. Figure 5 is a graphical depiction of Y_{j_i} . Y_{j_i} is equal to the area under $y_{j_i}(d_j, S_A, S_B)$ from $a_{j_{i-1,i}}$ to $a_{j_{i,i+1}}$.

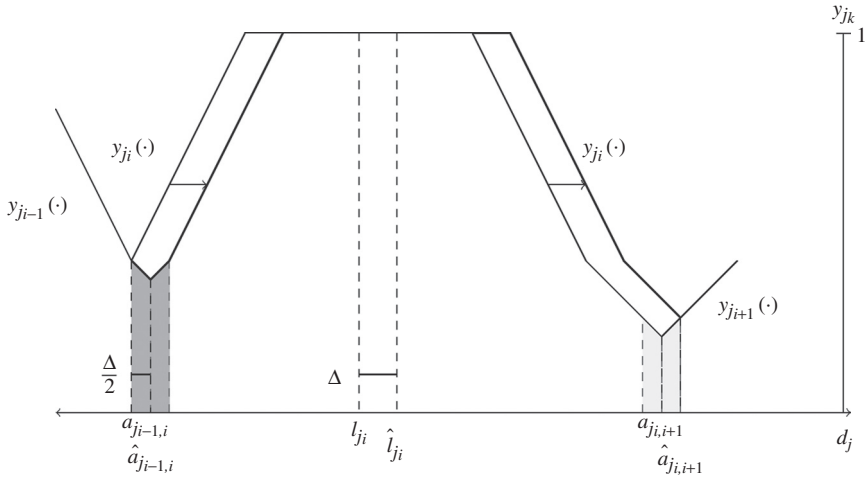

Figure 5: Effect of a marginal shift in the location of product j_i by Δ from l_{j_i} to \hat{l}_{j_i} . The dark gray trapezoids on the left represent the increased demand for products j_{i-1} and j_i . The light gray trapezoids on the right represent the decreased demand for products j_i and j_{i+1}

Proof of Lemma 1: Consider two firm j products, j_i and j_k , $i < k$, where $y_{j_i}(a_{j_{i,i+1}}(S_j), S_A, S_B) = 0$ and $y_{j_k}(a_{j_{k-1,k}}(S_j), S_A, S_B) > 0$. Then fixing prices and

shifting $\{l_m\}_{m=i+1}^{k-1}$ marginally by the same amount counterclockwise, no product experiences a fall in market share (at least to a first order effect), but the market shares (sales) of products j_{k-1} and j_k both strictly increase. Hence, firm j 's profits must increase.

Suppose instead, $y_{j_i}(a_{j_{i+1}}(S_j), S_A, S_B) > 0$ and $y_{j_k}(a_{j_{k-1,k}}(S_j), S_A, S_B) = 0$. Then fixing prices and shifting $\{l_m\}_{m=i+1}^{k-1}$ marginally by the same amount clockwise, no product experiences a fall in market share, but the market shares of products j_i and j_{i+1} strictly increase. Hence, firm j 's profits must increase. ■

Proof of Lemma 2: Because each firm j product is isolated, each firm j product faces the same demand curve. It follows that charging the same price at each product, and hence capturing the same market share is a best response. To prove uniqueness, we show that $\Pi_j(S_A, S_B)$ is strictly quasi-concave in $p_{j_i} \forall i \in N_j$, implying that this best response is unique.

Note that $y_{j_i}(d_j, S_A, S_B)$ is a continuous, piecewise linear function of p_{j_i} and l_{j_i} ; since $Y_{j_i}(S_A, S_B)$ is the integral of $y_{j_i}(d_j, S_A, S_B)$, $Y_{j_i}(S_A, S_B)$ is C^1 as a function of $\{p_{j_i}, l_{j_i}\}_{i=1}^{n_j}$.

The marginal profit function of firm j is differentiable with respect to p_{j_i} and l_{j_i} everywhere except at prices and locations where the partition of firm $-j$ products defined by $L(\cdot)$, $M(\cdot)$, $H(\cdot)$ and $V(\cdot)$ changes. At these points the number of firm $-j$ products against which product j_i competes changes discontinuously.

Because product j_i is isolated, $y_{j_i}(a_{j_{i-1,i}}(S_j), S_A, S_B) = 0$. If $p_{j_i} \leq \min\{p_{-j_k}\}$, then $y_{j_i}(l_{j_i}, S_A, S_B) = 1$ and marginal profit decreases linearly – the coefficient on p_{j_i} is $-4/(T)$. Hence, marginal profit is strictly decreasing over this range. If $p_{j_i} > \min\{p_{-j_k}\}$, then $y_{j_i}(l_{j_i}, S_A, S_B) < 1$ and the marginal profit function is a series of piecewise quadratic convex functions of p_{j_i} over this range – the leading term coefficient is $(2|H_{j_i}(l_{j_i}, S_A, S_B)| + |M_{j_i}(l_{j_i}, S_A, S_B)|)/(2T^2)$. Within each section, the number of competing $-j$ products remains constant. Each section of the piecewise quadratic function has two real solutions over the domain of \mathcal{R}^+ (else profit can increase without bound). The larger root of the quadratic in each section is where the implied product j_i market share is zero. Hence, the marginal profit function has only one root associated with a maximum. ■

Proof of Lemma 3: Fix an arbitrary product line profile, S_{-j} for the rival, and consider a product line profile for firm j with n_j products. By fixing the prices and locations of the other firm j products we can analyze the impact of a marginal shift in l_{j_i} and p_{j_i} . Using eq. [7],

$$\frac{\partial \pi_j}{\partial l_{j_i}} = p_{j_{i-1}} \frac{\partial Y_{j_{i-1}}}{\partial l_{j_i}} + p_{j_i} \frac{\partial Y_{j_i}}{\partial l_{j_i}} + p_{j_{i+1}} \frac{\partial Y_{j_{i+1}}}{\partial l_{j_i}}.$$

As Figure 5 shows, this is equal to

$$\frac{y_j(a_{j-1,i}(S_j), S_A, S_B)(p_j + p_{j-1}) - y_j(a_{j,i+1}(S_j), S_A, S_B)(p_j + p_{j+1})}{2}. \tag{8}$$

Similarly,

$$\frac{\partial \pi_j}{\partial p_j} = Y_j + p_{j-1} \frac{\partial Y_{j-1}}{\partial p_j} + p_j \frac{\partial Y_j}{\partial p_j} + p_{j+1} \frac{\partial Y_{j+1}}{\partial p_j}.$$

As Figure 6 shows, this is equal to

$$Y_j(S_A, S_B) - 2p_j \frac{y_j(l_j, S_A, S_B)}{T} + \frac{y_j(a_{j-1,i}(S_j), S_A, S_B)(p_{j-1} + p_j) + y_j(a_{j,i+1}(S_j), S_A, S_B)(p_{j+1} + p_j)}{2T}. \tag{9}$$

For S_j to be a best response to S_{-j} (fixing n_j), eqs [8] and [9] evaluated at (S_j, S_{-j}) must be zero. Since by assumption no firm j product is isolated, this gives $2n_j - 1$ equations in $2n_j - 1$ unknowns.⁷ Inspection reveals that uniform product pricing and equal distances between products solves this system of equations.

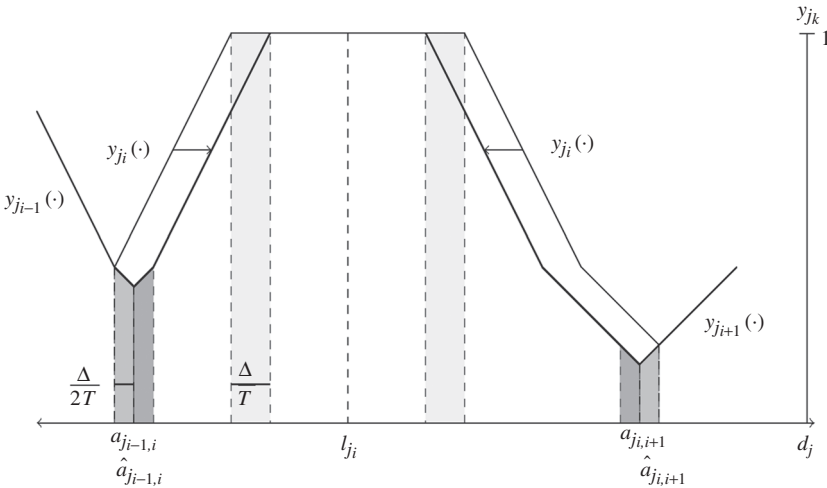

Figure 6: The effect of a marginal increase in the price charged for product j , by Δ from p_j to \hat{p}_j . The light gray rectangles represent a loss in demand for product j . The darker gray trapezoids represent a gain in demand for product j . The lighter gray trapezoids represent a gain in demand for products j_{-1} and j_{+1} .

⁷ l_j is normalized to 0.

An extensive numerical analysis indicates that this symmetric solution is the globally optimal best response. We compute firm j 's best response of location and price given the strategy of firm $-j$ and the number of firm j products. Using Lemma 2, we restrict firm $-j$ strategies to those that charge a uniform price p_{-j} for each product, where $p_{-j} \in [0, 0.1, \dots, 100]$. Without loss of generality we assume firm $-j$ spaces its products equally (expected sales of the rival do not depend on the spacing of local monopolies).

Best responses are calculated for $n_j \in \{2, \dots, 25\}$ and $n_{-j} \in \{2, \dots, 25\}$ using the numerical optimization algorithm "fmincon" in Matlab. The constraints associated with the algorithm are set to ensure that firm locations are sequentially ordered, each product serves a non-negative measure of consumers and prices are non-negative. We normalize \sqrt{T} to 100. For each n_j , for each competing firm strategy, equidistant product spacing and equal product pricing are always the unique best response. ■

Proof of Lemma 4: First note that the marginal change in demand for firm B due to a change in p_B is the same as the marginal change in demand for firm A due to a change in p_A . To see this, let $p_d = p_A - p_B$. Then

$$\frac{\partial Y_A}{\partial p_A} = \frac{\partial Y_A}{\partial p_d} = \frac{\partial(1 - Y_B)}{\partial p_d} = -\frac{\partial Y_B}{\partial p_d} = \frac{\partial Y_B}{\partial p_B}. \tag{10}$$

The first-order conditions for profit maximization of each firm with respect to its price gives

$$Y_A^* = -p_A^* \frac{\partial Y_A^*}{\partial p_A^*} \text{ and } Y_B^* = -p_B^* \frac{\partial Y_B^*}{\partial p_B^*}. \tag{11}$$

Combining eqs [10] and [11] gives

$$\frac{Y_A^*}{Y_B^*} = \frac{p_A^*}{p_B^*}.$$

Hence, $p_A^* \geq p_B^* \Leftrightarrow Y_A^* \geq Y_B^*$. It remains to show that in equilibrium firm B products are isolated. In contradiction to the hypothesis, suppose that firm B products are not isolated, i.e. $1/(2n_B^*) < (p_A^* - p_B^*)/T + 1/(2n_A^*)$. Then eq. [5] and $Y_B^* = 1 - Y_A^*$ implies

$$Y_A^* = \frac{n_A^*}{2n_B^*} \left(1 - 2n_B^* \frac{p_A^* - p_B^*}{T} \right)^2 < \frac{n_A^*}{2n_B^*} \min\left\{1, \frac{n_B^{*2}}{n_A^*}\right\} = \min\left\{\frac{n_A^*}{2n_B^*}, \frac{n_B^*}{2n_A^*}\right\} \leq 1/2 < Y_B^*. \quad \blacksquare$$

Proof of Proposition 1: The first-order condition for firm A profit maximization with respect to n_A is

$$\frac{\partial \pi_A}{\partial n_A} = \frac{p_A n_B}{2n_A^2} - F = 0.$$

Hence,

$$p_A^* = \frac{2Fn_A^{*2}}{n_B^*}. \quad [12]$$

The first-order condition for firm B profit maximization with respect to p_B is

$$\frac{\partial \pi_B}{\partial p_B} = Y_B - \frac{2p_B n_B}{T} = \frac{n_B}{2n_A} + 2n_B \frac{p_A - 2p_B}{T} = 0,$$

where we substitute for Y_B using eq. [4]. Substituting for p_A^* using eq. [12] yields

$$p_B^* = \frac{Fn_A^{*2}}{n_B^*} + \frac{T}{8n_A^*}. \quad [13]$$

The first-order condition for firm A profit maximization with respect to p_A is

$$\frac{\partial \pi_A}{\partial p_A} = Y_A - \frac{2p_A n_B}{T} = 1 - \frac{n_B}{2n_A} - 2n_B \frac{2p_A - p_B}{T} = 0, \quad [14]$$

where we have substituted for Y_A using eq. [3]. Substituting for p_A and p_B using eqs [12] and [13] into eq. [14] then yields

$$n_B^* = 4n_A^*(T - 6Fn_A^{*2})/T. \quad [15]$$

The first-order condition for firm B profit maximization with respect to n_B is

$$\frac{\partial \pi_B}{\partial n_B} = \frac{p_B Y_B}{n_B} - F = 0. \quad [16]$$

Hence, eqs [12], [13], [15] and [16] imply that in equilibrium

$$\frac{(T - 8Fn_A^{*2})(144F^2n_A^{*4} - 32Fn_A^{*2}T + T^2)}{32n_A^{*2}(T - 6Fn_A^{*2})} = 0.$$

Solving yields

$$n_A^* = n_B^* = \frac{1}{2} \sqrt{\frac{T}{2F}},$$

which implies that

$$p_A^* = p_B^* = \sqrt{\frac{FT}{2}}.$$

Hence, in the unique equilibrium $\pi_A^* = \pi_B^* = 0$.⁸ The equilibrium is unique because firm profit is continuously differentiable everywhere in price and product concentration and the above analysis shows there is only one solution to the first-order conditions. ■

Proof of Proposition 2: In equilibrium either $1/(2n_B^*) \geq 1/(2n_A^*) + (p_A^* - p_B^* - a)/T$ or $1/(2n_B^*) < 1/(2n_A^*) + (p_A^* - p_B^* - a)/T$. This implies that in equilibrium at least one firm's representative product is an isolated product (if we have equality then all products are isolated). As in the previous proof, the scalability of product concentration then immediately implies that this firm's profits must be zero. ■

Proof of Proposition 3: As in a symmetric firm setting, letting $p_d = p_A - p_B$, we have

$$\frac{\partial Y_A}{\partial p_A} = \frac{\partial(1 - Y_B)}{\partial p_d} = -\frac{\partial Y_B}{\partial p_d} = \frac{\partial Y_B}{\partial p_B}. \quad [17]$$

Profit maximization implies

$$Y_A^* = -p_A^* \frac{\partial Y_A^*}{\partial p_A^*} \text{ and } Y_B^* = -(p_B^* - c_B) \frac{\partial Y_B^*}{\partial p_B^*}. \quad [18]$$

Combining eqs [17] and [18] gives

$$\frac{Y_A^*}{Y_B^*} = \frac{p_A^*}{p_B^* - c_B}$$

Hence, $p_A^* \geq p_B^* - c_B \Leftrightarrow Y_A^* \geq Y_B^*$.

Assume that $p_A^* > p_B^* + a$ and $1/(2n_B^*) > 1/(2n_A^*) + (p_A^* - p_B^* - a)/T$ (we show later that these assumptions hold in equilibrium). Firm profits are

$$\pi_A = p_A Y_A - n_A F_A = p_A \left(1 - \frac{n_B}{2n_A} + 2n_B \frac{p_B - p_A + a}{T} \right) - n_A F_A$$

$$\pi_B = (p_B - c_B) Y_B - n_B F_B = (p_B - c_B) \left(\frac{n_B}{2n_A} - 2n_B \frac{p_B - p_A + a}{T} \right) - n_B F_B.$$

The four first-order conditions are

$$\frac{\partial \pi_A}{\partial p_A} = Y_A - \frac{2n_B p_A}{T} = 0 \quad [19]$$

⁸ The assumption that all consumers purchase the good implies that $V \geq \sqrt{\frac{9FT}{2}}$.

$$\frac{\partial \pi_A}{\partial n_A} = \frac{n_B p_A}{2n_A^2} - F_A = 0 \quad [20]$$

$$\frac{\partial \pi_B}{\partial p_B} = Y_B - 2n_B \frac{p_B - c_B}{T} = 0 \quad [21]$$

$$\frac{\partial \pi_B}{\partial n_B} = Y_B \frac{p_B - c_B}{n_B} - F_B = 0. \quad [22]$$

The first-order condition for firm B profit maximization with respect to its product concentration immediately implies that firm B earns zero profits. Solving eq. [22] for $Y_B^* = \frac{n_B^* F_B}{p_B^* - c_B}$ and substituting into eq. [21], yields

$$p_B^* = \sqrt{\frac{F_B T}{2}} + c_B. \quad [23]$$

From eq. [20] we get

$$p_A^* = \frac{2F_A n_A^{*2}}{n_B^*}. \quad [24]$$

Substituting $Y_A^* = 1 - Y_B^* = 1 - \frac{n_B^* F_B}{p_B^* - c_B}$ into eq. [19], gives

$$1 - \frac{n_B^* F_B}{p_B^* - c_B} = \frac{2n_B^* p_A^*}{T}.$$

Substituting for p_A^* using eq. [24] and p_B^* using eq. [23], we solve for

$$n_B^* = \frac{T - 4F_A n_A^{*2}}{\sqrt{2F_B T}}. \quad [25]$$

Substituting eqs [23], [24] and [25] into eq. [19], reveals that n_A is given by the solution to a cubic equation,

$$G(n_A) = -8F_A(2\alpha + 3\beta)n_A^3 + 4F_A T n_A^2 + 4T(\alpha + \beta)n_A - T^2,$$

where $\alpha = a + c_B$ and $\beta = \sqrt{2F_B T}$. Because the discriminant of $G(n_A)$ is positive, $G(n_A)$ has 3 real roots. Also, since the leading term coefficient is negative and $G(0) = -2T^2 < 0$, G has at least one negative root. To be consistent with our initial premise that $1/(2n_B^*) > 1/(2n_A^*) + (p_A^* - p_B^* - a)/T$, we must have $n_A^* > T/(2(\alpha + \beta))$. $G(n_A)$ evaluated at this lower bound is positive, implying that such a solution exists and n_A^* is the largest root of $G(n_A)$. Define

$$\underline{n}_A = \sqrt{\frac{T(2\alpha + \beta)}{8F_A(\alpha + \beta)}} \quad \text{and} \quad \bar{n}_A = \sqrt{\frac{T(\alpha + \beta)}{2F_A(2\alpha + 3\beta)}}.$$

Evaluating G at these points yields

$$G(\underline{n}_A) = \frac{T^2\beta(\sqrt{F_B}\sqrt{2\alpha + \beta} - \sqrt{F_A}\sqrt{\alpha + \beta})}{2\sqrt{F_A}\sqrt{(\alpha + \beta)^3}} > 0 \quad \text{and} \quad G(\bar{n}_A) = -\frac{T^2\beta}{2\alpha + 3\beta} < 0.$$

Hence, $\underline{n}_A < n_A^* < \bar{n}_A$. We now show that $p_A^* > p_B^* + a$. Using eqs [23], [24] and [25] this is equivalent to showing

$$\frac{8F_A(n_A^*)^2(\alpha + \beta) - T(2\alpha + \beta)}{2(T - 4F_A(n_A^*)^2)} > 0,$$

which holds since $\underline{n}_A < n_A^* < \bar{n}_A$.

Uniqueness is assured by showing that $p_A^* > p_B^* + a$ and $1/(2n_B^*) > 1/(2n_A^*) + (p_A^* - p_B^* - a)/T$ must hold in equilibrium. To see this consider the three other possible outcomes.

Case 1: $p_A^* > p_B^* + a$, $1/(2n_B^*) \leq 1/(2n_A^*) + (p_A^* - p_B^* - a)/T$. Let

$$X^* = \frac{1}{2n_B^*} - \left(\frac{p_A^* - p_B^* - a}{T}\right) < \min\left\{\frac{1}{2n_A^*}, \frac{1}{2n_B^*}\right\}.$$

$$Y_A^* = 2n_A^*n_B^*X^{*2} < 2n_A^*n_B^*\left(\min\left\{\frac{1}{2n_A^*}, \frac{1}{2n_B^*}\right\}\right)^2 = \min\left\{\frac{n_B^*}{2n_A^*}, \frac{n_A^*}{2n_B^*}\right\} < 1/2 < Y_B^*.$$

but this implies $p_A^* < (p_B^* - c_B)$ which contradicts $p_A^* > p_B^* + a$.

Case 2: $p_A^* \leq p_B^* + a$, $1/(2n_B^*) \geq 1/(2n_A^*) + (p_A^* - p_B^* - a)/T$. Let

$$X^* = \frac{1}{2n_A^*} + \left(\frac{p_A^* - p_B^* - a}{T}\right) < \min\left\{\frac{1}{2n_A^*}, \frac{1}{2n_B^*}\right\}.$$

Demand for firm B is

$$Y_B^* = 2n_A^*n_B^*X^{*2} < 2n_A^*n_B^*\left(\min\left\{\frac{1}{2n_A^*}, \frac{1}{2n_B^*}\right\}\right)^2 = \min\left\{\frac{n_B^*}{2n_A^*}, \frac{n_A^*}{2n_B^*}\right\} < 1/2 < Y_A^*.$$

Hence, from lemma 4, $p_A^* > p_B^* - c_B$. The four first-order conditions are

$$\frac{\partial \pi_A}{\partial p_A} = 1 - Y_B - \frac{2p_A Y_B}{XT} = 0 \tag{26}$$

$$\frac{\partial \pi_B}{\partial p_B} = Y_B \left(1 - \frac{2(p_B - c_B)}{XT}\right) = 0 \tag{27}$$

$$\frac{\partial \pi_A}{\partial n_A} = \frac{p_A Y_B}{n_A} \left(\frac{1}{n_A X} - 1 \right) - F_A = 0 \quad [28]$$

$$\frac{\partial \pi_B}{\partial n_B} = \frac{(p_B - c_B) Y_B}{n_B} - F_B = 0. \quad [29]$$

Combining eqs [26], [27] and $Y_A = 1 - Y_B$ yields

$$Y_A^* = \frac{p_A^*}{p_A^* + p_B^* - c_B} \quad \text{and} \quad Y_B^* = \frac{p_B^* - c_B}{p_A^* + p_B^* - c_B}. \quad [30]$$

The first-order condition for firm B profit maximization with respect to its price implies

$$X^* = \frac{2(p_B^* - c_B)}{T}. \quad [31]$$

Substituting eq. [31] into Y_B^* gives

$$Y_B^* = \frac{8n_A^* n_B^* (p_B^* - c_B)^2}{T^2}. \quad [32]$$

Substituting for Y_B^* using eq. [32] into eq. [29] we solve for

$$n_A^* = \frac{F_B T^2}{8(p_B^* - c_B)^3}. \quad [33]$$

Using the definition of X^* and eq. [31] gives

$$1/(2n_A^*) + (p_A^* - p_B^* - a)/T = \frac{2(p_B^* - c_B)}{T}.$$

Because $p_A^* \leq p_B^* + a$ this further implies that $p_B^* \geq c_B + \sqrt{\frac{F_B T}{2}}$. Finally, substituting eqs [30], [31] and [33] into eq. [28] implies

$$8p_A^* (p_B^* - c_B)^4 (4(p_B^* - c_B)^2 - F_B T) - (p_A^* + p_B^* - c_B) F_A F_B^2 T^3 = 0.$$

This equality can never be satisfied since $p_A^* > p_B^* - c_B$ and $p_B^* \geq c_B + \sqrt{\frac{F_B T}{2}}$.

Case 3: $p_A^* \leq p_B^* + a$, $1/(2n_A^*) \leq 1/(2n_B^*) + (p_A^* - p_B^* - a)/T$ The second assumption implies that firm A products are isolated, so that firm A makes zero profit. This combined with the first assumption imply that $n_A^* < n_B^*$. If $Y_A^* \geq 1/2 \geq Y_B^*$ then $p_A^* > p_B^* - c_B$, which implies firm B negative profit. Conversely if, instead, $Y_A^* < 1/2 < Y_B^*$, then there exists a deviation by firm A that gives it positive profit, contradicting the posited equilibrium. To see this, observe that firm A 's demand is

$$Y_A^* = \frac{n_A^*}{2n_B^*} + 2n_A^* \frac{p_B^* + a - p_A^*}{T} < 1/2 \quad \text{implying that} \quad \frac{n_A^*}{n_B^*} < 1. \quad [34]$$

Profit maximization by firm B requires that in equilibrium

$$\frac{\partial \pi_B}{\partial n_B} = (p_B - c_B) \frac{n_A}{2n_B^2} - F_B = 0. \quad [35]$$

Substituting the inequality in eq. [34] into eq. [35] reveals that $\frac{p_B^* - c_B}{2} > n_B^* F_B$. If firm A deviates and sets $p_A = p_B^* + a$ and $n_A = n_B^*$, then $Y_A = 1/2$ and its profit is strictly positive. ■

Proof of Proposition 4: In the second stage, firm i maximizes π_i given product concentrations, $n_A = n_B = n$ and the prices of its rival j . With $n_A = n_B$, it is straightforward to show that firms choose $p_A = p_B$. But then prices drop out of the social planner's objective,

$$\begin{aligned} SS &= V - 4n^2 \int_0^{\frac{1}{2n}} \left(\int_{d_A}^{\frac{1}{2n}} T d_A dd_B + \int_0^{d_A} T d_B dd_B \right) dd_A - 2nF \\ &= V - \frac{T}{6n} - 2nF. \end{aligned}$$

Differentiating SS with respect to n gives the social planner's first-order condition:⁹

$$\frac{\partial SS}{\partial n} = \frac{T}{6n_{SP}^2} - 2F = 0.$$

Denoting the optimal level of product concentration per firm as n_{SP}^* , we solve for

$$\begin{aligned} n_{SP}^* &= \sqrt{\frac{T}{12F}} < \sqrt{\frac{T}{8F}} = n^*, \\ SS_{SP}^* &= V - \sqrt{\frac{4FT}{3}} > V - \sqrt{\frac{25FT}{18}} = SS^*. \end{aligned}$$

Proof of Proposition 5: Case 1 (small m). We first consider the possibility that m is small enough that in equilibrium no consumer with location shocks $\{d_j, d_{-j}\} = \{\frac{1}{2n_j}, 0\}$, $j \in \{A, B\}$ purchases from firm j , i.e. $m < |p_A^* - p_B^*| + T \max\{\frac{1}{2n_A^*}, \frac{1}{2n_B^*}\}$. That is, m is small enough that, in equilibrium,

⁹ Second-order conditions are clearly satisfied.

any consumer who is located at the same point as one firm's product and at the edge of the rival's product service area will patronize the former firm regardless of their taste preference. Under this assumption, firm market shares are

$$\begin{aligned}
 Y_A = \frac{2n_A n_B}{m} & \left[\int_0^{\frac{1}{2n_A}} \int_0^{\frac{1}{2n_B}} \left(\int_{(d_A-d_B)T+p_A-p_B}^{\frac{T}{2n_A}+p_A-p_B} 1 \, dz - \int_m^{\frac{T}{2n_A}+p_A-p_B} 1 \, dz \right) dd_B dd_A \right. \\
 & + \int_{\frac{p_B-p_A+m}{T}}^{\frac{1}{2n_A}} \int_0^{d_A+\frac{p_A-p_B-m}{T}} \int_m^{(d_A-d_B)T+p_A-p_B} 1 \, dz dd_B dd_A \\
 & \left. - \int_0^{\frac{1}{2n_B}+\frac{p_B-p_A-m}{T}} \int_{d_A+\frac{p_A-p_B+m}{T}}^{\frac{1}{2n_B}} \int_{(d_A-d_B)T+p_A-p_B}^{-m} 1 \, dz dd_A dd_B \right]
 \end{aligned}$$

$$\begin{aligned}
 Y_B = \frac{2n_A n_B}{m} & \left[\int_0^{\frac{1}{2n_A}} \int_0^{\frac{1}{2n_B}} \left(\int_{-\frac{T}{2n_B}+p_B-p_A}^{(d_A-d_B)T+p_A-p_B} 1 \, dz - \int_{-\frac{T}{2n_B}+p_B-p_A}^{-m} 1 \, dz \right) dd_B dd_A \right. \\
 & + \int_0^{\frac{1}{2n_B}+\frac{p_B-p_A-m}{T}} \int_{d_A+\frac{p_A-p_B+m}{T}}^{\frac{1}{2n_B}} \int_{(d_A-d_B)T+p_A-p_B}^{-m} 1 \, dz dd_A dd_B \\
 & \left. - \int_{\frac{p_B-p_A+m}{T}}^{\frac{1}{2n_A}} \int_0^{d_A+\frac{p_A-p_B-m}{T}} \int_m^{(d_A-d_B)T+p_A-p_B} 1 \, dz dd_B dd_A \right].
 \end{aligned}$$

Simplifying yields

$$\begin{aligned}
 Y_A = \frac{n_A n_B}{24m} & \left\{ \frac{3T(n_A + n_B)}{n_A^2 n_B^2} + \frac{12n_A(p_B - p_A + m) - 6T}{n_A^2 n_B} \right. \\
 & \left. + \frac{1}{T^2} \left[\left(\frac{(2n_B(p_A - p_B + m) - T)}{n_B} \right)^3 - \left(\frac{(2n_A(p_B - p_A + m) - T)}{n_A} \right)^3 \right] \right\}
 \end{aligned}$$

$$\begin{aligned}
 Y_B = \frac{n_A n_B}{24m} & \left\{ \frac{3T(n_A + n_B)}{n_A^2 n_B^2} + \frac{12n_B(p_A - p_B + m) - 6T}{n_A n_B^2} \right. \\
 & \left. - \frac{1}{T^2} \left[\left(\frac{(2n_B(p_A - p_B + m) - T)}{n_B} \right)^3 - \left(\frac{(2n_A(p_B - p_A + m) - T)}{n_A} \right)^3 \right] \right\}.
 \end{aligned}$$

Differentiating firm profit and applying symmetry yields the equilibrium outcomes:

$$p_A^* = p_B^* = p_{m_s}^* = \frac{2FT}{\sqrt{8FT} - m} \quad \text{and} \quad n_A^* = n_B^* = n_{m_s}^* = \frac{1}{2} \sqrt{\frac{T}{2F}}.$$

Our initial assumption that $m < |p_A^* - p_B^*| + T \max\{\frac{1}{2n_A^*}, \frac{1}{2n_B^*}\}$ holds if and only if $m < \sqrt{2FT}$. In equilibrium,

$$\pi_A^* = \pi_B^* = \frac{m\sqrt{2FT}}{4(\sqrt{8FT} - m)} > 0. \tag{36}$$

The second-order conditions when m is small are

$$\begin{bmatrix} \frac{\partial^2 \pi_i}{\partial p_i^2} & \frac{\partial^2 \pi_i}{\partial p_i \partial n_i} \\ \frac{\partial^2 \pi_i}{\partial p_i \partial n_i} & \frac{\partial^2 \pi_i}{\partial n_i^2} \end{bmatrix} \bigg|_{\substack{n_A = n_B = n_{m_s}^* \\ p_A = p_B = p_{m_s}^*}} = \begin{bmatrix} \frac{m - 2\beta}{\beta^2} & \frac{2m\beta - m^2 - 2\beta^2}{2T(m - 2\beta)} \\ \frac{2m\beta - m^2 - 2\beta^2}{2T(m - 2\beta)} & \frac{8F^2}{m - 2\beta} \end{bmatrix},$$

where $\beta = \sqrt{2FT}$. This matrix is negative definite, implying a maximum.

Case 2 (large m). If $m > \sqrt{2FT}$, then in equilibrium some consumers who realize location shocks $\{d_j, d_{-j}\} = \{\frac{1}{2n_j}, 0\}$, $j \in \{A, B\}$ still purchase from firm j . In this case the market shares and profits of the two firms are given by

$$Y_A = \frac{2n_A n_B}{m} \int_0^{\frac{1}{2n_A}} \int_0^{\frac{1}{2n_B}} \int_{T(d_A - d_B) + p_A - p_B}^m 1 \, dz \, dd_B \, dd_A$$

$$= \frac{1}{2} + \frac{p_B - p_A}{2m} + \frac{T}{m} \left(\frac{1}{8n_B} - \frac{1}{8n_A} \right)$$

$$Y_B = \frac{2n_A n_B}{m} \int_0^{\frac{1}{2n_A}} \int_0^{\frac{1}{2n_B}} \int_{-m}^{T(d_A - d_B) + p_A - p_B} 1 \, dz \, dd_B \, dd_A$$

$$= \frac{1}{2} + \frac{p_A - p_B}{2m} + \frac{T}{m} \left(\frac{1}{8n_A} - \frac{1}{8n_B} \right)$$

$$\pi_A(S_A, S_B) = \left(\frac{1}{2} + \frac{p_B - p_A}{2m} + \frac{T}{m} \left[\frac{1}{8n_B} - \frac{1}{8n_A} \right] \right) p_A - n_A F$$

$$\pi_B(S_A, S_B) = \left(\frac{1}{2} + \frac{p_A - p_B}{2m} + \frac{T}{m} \left[\frac{1}{8n_A} - \frac{1}{8n_B} \right] \right) p_B - n_B F.$$

Differentiating firm profit and applying symmetry yields the equilibrium outcomes:

$$p_A^* = p_B^* = p_{m_L}^* = m \quad \text{and} \quad n_A^* = n_B^* = n_{m_L}^* = \frac{1}{2} \sqrt{\frac{T}{2F}}, \quad \text{so that}$$

$$\pi_A^* = \pi_B^* = \frac{1}{2} \left(m - \sqrt{\frac{FT}{2}} \right) > 0. \tag{37}$$

The second-order conditions are

$$\begin{bmatrix} \frac{\partial^2 \pi_i}{\partial p_i^2} & \frac{\partial^2 \pi_i}{\partial p_i \partial n_i} \\ \frac{\partial^2 \pi_i}{\partial p_i \partial n_i} & \frac{\partial^2 \pi_i}{\partial n_i^2} \end{bmatrix} \Bigg|_{\substack{n_A = n_B = n_{m_L}^* \\ p_A = p_B = p_{m_L}^*}} = \begin{bmatrix} -\frac{1}{m} & \frac{F}{m} \\ \frac{F}{m} & -4\sqrt{\frac{2F^3}{T}} \end{bmatrix}.$$

Hence, we have a maximum since the matrix is negative definite. ■

Proof of Proposition 6: Let $\pi^*(m, F, T)$ denote equilibrium firm profit as a function of heterogeneous taste parameter m , product establishment cost F and transportation cost T . Note that profit is continuous in the parameters since

$$\lim_{m \rightarrow \sqrt{2FT}} \pi^*(m, F, T) = \frac{\sqrt{FT}}{2} = \lim_{m \rightarrow \sqrt{2FT}^+} \pi^*(m, F, T).$$

Differentiating firm profit directly with respect to T gives the result:

$$\frac{\partial \pi^*(m, F, T)}{\partial T} = \begin{cases} -\frac{m^2 F}{4\sqrt{2FT}(\sqrt{8FT} - m)^2} & \text{if } m < \sqrt{2FT} \\ -\frac{2F(m - \sqrt{2FT})}{(\sqrt{8FT} - m)^2} & \text{if } m > \sqrt{2FT} \end{cases},$$

which is strictly negative for all $T \neq m^2/(2F)$. ■

Proof of Proposition 7: First we assume that λ, F_1 and F_2 are such that $Y_{12} > 0$. There are four possible cases:

1. $p_1 \leq p_2$ and $\left(\frac{1}{2n_2} - \frac{p_1 - p_2}{T}\right) - \frac{1}{2n_1} \leq 0$.
2. $p_1 \geq p_2$ and $\left(\frac{1}{2n_2} - \frac{p_1 - p_2}{T}\right) - \frac{1}{2n_1} \leq 0$.
3. $p_1 \leq p_2$ and $\left(\frac{1}{2n_2} - \frac{p_1 - p_2}{T}\right) - \frac{1}{2n_1} > 0$.
4. $p_1 \geq p_2$ and $\left(\frac{1}{2n_2} - \frac{p_1 - p_2}{T}\right) - \frac{1}{2n_1} > 0$.

We will rule out the latter two possibilities (which would imply that even though $F_1 > F_2$, firms make zero profits from circle 2, but positive profits from circle 1). We present case 1 in detail; analyses of the other three cases are similar.

Case 1: In the neighborhood of an equilibrium with $p_{A_i} \geq p_{B_i}$, $i = 1, 2$, we have

$$\begin{aligned} \pi_B = & p_{B_1} \left(\lambda \left(1 - 4n_{A_1}n_{B_1} \int_0^{\frac{1}{2n_{A_1}}} \int_{d_{A_1} + \frac{p_{A_1} - p_{B_1}}{T}}^{\frac{1}{2n_{B_1}}} 1 dd_{B_1} dd_{A_1} \right) \right. \\ & + (1 - \lambda) \left(1 - 4n_{A_2}n_{B_1} \int_0^{\frac{1}{2n_{A_2}}} \int_{d_{A_2} + \frac{p_{A_2} - p_{B_1}}{T}}^{\frac{1}{2n_{B_1}}} 1 dd_{B_1} dd_{A_2} \right) \Big) \\ & + p_{B_2} \left((1 - \lambda) 4n_{A_1}n_{B_2} \int_0^{\frac{1}{2n_{B_2}}} \int_{d_{B_2} + \frac{p_{B_2} - p_{A_1}}{T}}^{\frac{1}{2n_{A_1}}} 1 dd_{A_1} dd_{B_2} \right. \\ & \left. + \lambda \left(1 - 4n_{A_2}n_{B_2} \int_0^{\frac{1}{2n_{A_2}}} \int_{d_{A_2} + \frac{p_{A_2} - p_{B_2}}{T}}^{\frac{1}{2n_{B_2}}} 1 dd_{B_2} dd_{A_2} \right) \right) - (F_1n_{B_1} + F_2n_{B_2}). \end{aligned}$$

The first-order conditions for firm B are

$$\frac{\partial \pi_B}{\partial p_{B_1}} = \lambda \left(Y_{B_{11}} - \frac{2p_{B_1}n_{B_1}}{T} \right) + (1 - \lambda) \left(Y_{B_{12}} - \frac{2p_{B_1}n_{B_1}}{T} \right) = 0$$

$$\frac{\partial \pi_B}{\partial p_{B_2}} = \lambda \left(Y_{B_{22}} - \frac{2p_{B_2}n_{B_2}}{T} \right) + (1 - \lambda) \left(Y_{B_{21}} - \frac{2p_{B_2}n_{A_1}}{T} \right) = 0$$

$$\frac{\partial \pi_B}{\partial n_{B_1}} = \lambda Y_{B_{11}} \frac{p_{B_1}}{n_{B_1}} + (1 - \lambda) Y_{B_{12}} \frac{p_{B_1}}{n_{B_1}} - F_1 = 0$$

$$\frac{\partial \pi_B}{\partial n_{B_2}} = \frac{(1 - \lambda)n_{A_1}p_{B_2}}{2n_{B_2}^2} + \lambda Y_{B_{22}} \frac{p_{B_2}}{n_{B_2}} - F_2 = 0.$$

where we have substituted $\frac{n_{A_1}}{2n_{B_2}} = Y_{B_{21}} + \frac{\left(\frac{p_{B_2} - p_{A_1}}{T}\right) + \frac{1}{2n_{B_2}} - \frac{1}{2n_{A_1}}}{\frac{1}{2n_{A_1}}}$ in $\frac{\partial \pi_B}{\partial n_{B_2}}$. Imposing symmetry, substituting $Y_{jj} = \frac{1}{2}$ and rearranging the first-order conditions yields:

$$0 = \frac{\lambda}{2} + (1 - \lambda)Y_{12} - \frac{2p_1n_1}{T} \tag{38}$$

$$0 = \frac{\lambda}{2} + (1 - \lambda)Y_{21} - \frac{2p_2}{T} (\lambda n_2 + (1 - \lambda)n_1) \tag{39}$$

$$0 = p_1 \left(\frac{\lambda}{2} + (1 - \lambda)Y_{12} \right) - F_1 n_1 \tag{40}$$

$$0 = p_2 \left((1 - \lambda) \frac{n_1}{2n_2} + \frac{\lambda}{2} \right) - F_2 n_2. \tag{41}$$

We see immediately from eq. [40] that firms earn zero profits on circle 1, and from eq. [41] that firms earn strictly positive profits on circle 2 when $(\frac{p_2 - p_1}{T}) + \frac{1}{2n_2} - \frac{1}{2n_1} < 0$ (which implies that $\frac{n_1}{2n_2} < Y_{21}$). Using eq. [40] to substitute for

$$\frac{\lambda}{2} + (1 - \lambda)Y_{12} = \frac{F_1 n_1}{p_1}$$

into eq. [38] and solving for p_1 yields

$$p_1 = \sqrt{\frac{TF_1}{2}}.$$

Also, n_1 and n_2 solve

$$\frac{2\sqrt{2}\sqrt{TF_1}n_1 - T\lambda}{(1 - \lambda)} = \frac{n_1}{n_2} \left(T + 4n_2 \left(\frac{4F_2 n_2^2}{2[(1 - \lambda)n_1 + \lambda n_2]} - \frac{\sqrt{TF_1}}{\sqrt{2}} \right) \right) \tag{42}$$

$$T - \sqrt{2}\sqrt{TF_1}n_1 = 4F_2 n_2^2. \tag{43}$$

Solving eq. [43] for n_1 and substituting into eq. [42] yields

$$\frac{2T(1 - \frac{\lambda}{2}) - 8F_2 n_2^2}{(1 - \lambda)} = \frac{(T - 4F_2 n_2^2)}{\sqrt{2}\sqrt{(TF_1)n_2}} \left(T + 4n_2 \left(\frac{4F_2 n_2^2}{2\lambda n_2 + \frac{\sqrt{2}(1 - \lambda)(T - 4F_2 n_2^2)}}{\sqrt{TF_1}} - \frac{\sqrt{TF_1}}{\sqrt{2}} \right) \right),$$

which can be reduced to the following fifth-degree polynomial equation, where $\eta = \sqrt{2F_1 T}$:

$$64F_2^2 F_1 (1 - \lambda)(3 - \lambda)n_2^5 + 16F_2 \eta ((F_2 - F_1)(2 - \lambda)\lambda - F_2)n_2^4 - 8F_2 \eta^2 (1 - \lambda)(5 - 3\lambda)n_2^3 + 2T\eta(4F_2(1 - \lambda)^2 + \lambda F_1(4 - 3\lambda))n_2^2 + 4T\eta^2(1 - \lambda)^2 n_2 - T^2 \eta(1 - \lambda)^2 = 0.$$

Analogously, one can solve for the first-order conditions for the other three cases:

Case 2. $p_1 \geq p_2$ and $(\frac{1}{2n_2} - \frac{p_1 - p_2}{T}) - \frac{1}{2n_1} \leq 0$

$$\frac{\lambda}{2} + (1 - \lambda)Y_{12} = \frac{2p_1}{T} \left(\lambda n_1 + (1 - \lambda)n_2 \frac{\left(\frac{1}{2n_2} - \frac{p_1 - p_2}{T} \right)}{\frac{1}{2n_1}} \right) \tag{44}$$

$$\frac{\lambda}{2} + (1 - \lambda)Y_{21} = \frac{2p_2n_2}{T} \left(\lambda + (1 - \lambda) \frac{\left(\frac{1}{2n_2} - \frac{p_1 - p_2}{T} \right)}{\frac{1}{2n_1}} \right) \quad [45]$$

$$\frac{\lambda p_1}{2} + (1 - \lambda)p_1Y_{12} - F_1n_1 = 0 \quad [46]$$

$$\frac{\lambda p_2}{2} + (1 - \lambda)p_2Y_{21} - F_2n_2 = (1 - \lambda)p_2 \frac{\left(\frac{1}{2n_1} - \left(\frac{1}{2n_2} - \frac{p_1 - p_2}{T} \right) \right)}{\frac{1}{2n_1}}. \quad [47]$$

Case 3. $p_1 \leq p_2$ and $\left(\frac{1}{2n_2} - \frac{p_1 - p_2}{T} \right) - \frac{1}{2n_1} \geq 0$.

$$\frac{\lambda}{2} + (1 - \lambda)Y_{12} = \frac{2p_1n_1}{T} \left(\lambda + (1 - \lambda) \frac{\left(\frac{1}{2n_1} - \frac{p_2 - p_1}{T} \right)}{\frac{1}{2n_2}} \right) \quad [48]$$

$$\frac{\lambda}{2} + (1 - \lambda)Y_{21} = \frac{2p_2}{T} \left(\lambda n_2 + (1 - \lambda)n_1 \frac{\left(\frac{1}{2n_1} - \frac{p_2 - p_1}{T} \right)}{\frac{1}{2n_2}} \right) \quad [49]$$

$$\frac{\lambda p_1}{2} + (1 - \lambda)p_1Y_{12} - F_1n_1 = (1 - \lambda)p_1 \frac{\left(\frac{1}{2n_2} - \left(\frac{1}{2n_1} - \frac{p_2 - p_1}{T} \right) \right)}{\frac{1}{2n_2}} \quad [50]$$

$$\frac{\lambda p_2}{2} + (1 - \lambda)p_2Y_{21} - F_2n_2 = 0. \quad [51]$$

Case 4. $p_1 \geq p_2$ and $\left(\frac{1}{2n_2} - \frac{p_1 - p_2}{T} \right) - \frac{1}{2n_1} \geq 0$.

$$\frac{\lambda}{2} + (1 - \lambda)Y_{12} = \frac{2p_1}{T} (\lambda n_1 + (1 - \lambda)n_2) \quad [52]$$

$$\frac{\lambda}{2} + (1 - \lambda)Y_{21} = \frac{2p_2n_2}{T} \quad [53]$$

$$\frac{\lambda p_1}{2} + (1 - \lambda)p_1Y_{12} - F_1n_1 = (1 - \lambda)p_1 \frac{\left(\left(\frac{1}{2n_2} - \frac{p_1 - p_2}{T} \right) - \frac{1}{2n_1} \right)}{\frac{1}{2n_2}} \quad [54]$$

$$\frac{\lambda p_2}{2} + (1 - \lambda)p_2Y_{21} - F_2n_2 = 0. \quad [55]$$

Cases 1 and 4 are “symmetric”, as are Cases 2 and 3: relabeling p_1 as p_2 , p_2 as p_1 , n_1 as n_2 and n_2 as n_1 in Case 1, the sets of first-order conditions in Case 4 correspond to those in 1.

To rule out cases 3 and 4, we first characterize p_1 relative to p_2 . We know that $p_1 > p_2$ at $\lambda = 1$. As $p_1 = \sqrt{\frac{F_1 T}{2}}$ for $p_1 \geq p_2$, the critical λ that determines which price is higher sets $p_1 = p_2 = \sqrt{\frac{F_1 T}{2}}$. At $p_1 = p_2$, the first-order conditions [46] and [47] simplify to:

$$\frac{\lambda p_1}{2} + (1 - \lambda) \frac{n_1}{2n_2} p_1 - F_1 n_1 = 0$$

$$(1 - \lambda) p_1 \frac{n_1}{2n_2} + \frac{\lambda p_1}{2} - F_2 n_2 = 0.$$

Therefore, at $p_1 = p_2$, we have $F_1 n_1 = F_2 n_2 \Leftrightarrow \frac{F_1}{F_2} = \frac{n_2}{n_1}$.

In addition, the first-order conditions [44] and [45] are,

$$\frac{\lambda}{2} + (1 - \lambda) \frac{n_1}{2n_2} = p_1 \frac{2n_1}{T} \tag{56}$$

$$\frac{\lambda}{2} + (1 - \lambda) \left(1 - \frac{n_1}{2n_2}\right) = \frac{2p_1}{T} (\lambda n_2 + (1 - \lambda)n_1), \tag{57}$$

where $p_1 = p_2 = \sqrt{\frac{F_1 T}{2}}$. Substituting $n_2 = n_1 \frac{F_1}{F_2}$ and solving eq. [56] for n_1 yields

$$n_1 = \frac{\sqrt{T}(\lambda F_1 + F_2 - \lambda F_2)}{2\sqrt{2}F_1^{3/2}},$$

and solving eq. [57] for n_1 yields

$$n_1 = \frac{\sqrt{T}F_2(2F_1 - \lambda F_1 - F_2 + \lambda F_2)}{2\sqrt{2}F_1^{3/2}(\lambda F_1 + F_2 - \lambda F_2)}.$$

Equating these two solutions, we solve for

$$\lambda^* = \frac{\sqrt{F_2}\sqrt{8F_1 + F_2} - 3F_2}{2(F_1 - F_2)}.$$

Differentiation establishes that λ^* is decreasing in F_1 , and an application of L'Hospital's rule shows that $\lambda^* \rightarrow \frac{2}{3}$ as $F_2 \rightarrow F_1$.

We are now in a position to rule out Cases 3 and 4. First note that if $F_1 > F_2$, then when $\lambda = 0$ or $\lambda = 1$, $(\frac{1}{2n_1} - \frac{p_2 - p_1}{T}) - \frac{1}{2n_2} > 0$. Further, $(\frac{1}{2n_1} - \frac{p_2 - p_1}{T}) - \frac{1}{2n_2}$ is continuous in λ , so suppose there were a λ such that $(\frac{1}{2n_1} - \frac{p_2 - p_1}{T}) - \frac{1}{2n_2} = 0$. If $p_1 \leq p_2$, as in Cases 1 and 3 then $n_2 \geq n_1$ and $Y_{12} \geq Y_{21} = \frac{n_1}{2n_2}$. From the first-order eqs [48] and [49] for Case 3,

$$\frac{2p_1 n_1}{T} \geq \frac{1}{2} \geq \frac{2p_2}{T} (\lambda n_2 + (1 - \lambda)n_1) \geq \frac{2p_2 n_1}{T}.$$

But this implies that $p_1 = p_2$. By the assumption that $(\frac{1}{2n_1} - \frac{p_2 - p_1}{T}) - \frac{1}{2n_2} = 0$, we have $n_1 = n_2$, thus $F_1 = F_2$ by $\frac{F_1}{F_2} = \frac{n_2}{n_1}$ at $p_1 = p_2$, a contradiction. The analysis for Case 4 is similar. If $p_2 \leq p_1$, as in Cases 2 and 4 then $n_1 \geq n_2$ and $Y_{21} \geq Y_{12}$. From the Case 4 first order eqs [52] and [53],

$$\frac{2p_2n_2}{T} \geq \frac{1}{2} \geq \frac{2p_1}{T}(\lambda n_1 + (1 - \lambda)n_2) \geq \frac{2p_1n_2}{T}.$$

Again this implies that $p_1 = p_2$, and a contradiction obtains as above. Thus, we have that equilibrium is characterized by Cases 1 and 2.

To show that $n_1 < n_2$, we show that $n_1 \geq n_2$ implies a contradiction in Case 2. Under Case 2, $p_1 \geq p_2$ and $Y_{21} \geq Y_{12}$. If $n_1 \geq n_2$ then from eqs [44] and [45]

$$\frac{2p_2n_2}{T}(\lambda + (1 - \lambda)\gamma) \geq \frac{1}{2} \geq \frac{2p_1}{T}(\lambda n_1 + (1 - \lambda)n_2\gamma) \geq \frac{2p_1n_2}{T}(\lambda + (1 - \lambda)\gamma),$$

where

$$\gamma = 2n_1 \left(\frac{1}{2n_2} - \frac{(p_1 - p_2)}{T} \right).$$

Again this implies that $p_1 = p_2$. Thus, we have $n_1 > n_2$ and $F_1 > F_2$ at $p_1 = p_2$, which contradicts our finding that $\frac{F_1}{F_2} = \frac{n_2}{n_1}$ at $p_1 = p_2$.

From eq. [47], firm profit in Case 2 is

$$\begin{aligned} \pi_2 &= (1 - \lambda)p_2 \frac{\left(\frac{1}{2n_1} - \left(\frac{1}{2n_2} - \frac{(p_1 - p_2)}{T} \right) \right)}{\frac{1}{2n_1}} \\ &= (1 - \lambda)p_2 \left(1 - \frac{n_1}{n_2} + \frac{2n_1(p_1 - p_2)}{T} \right) \\ &= (1 - \lambda)p_2 \left(1 - \frac{n_1}{2n_2} \left(1 - \frac{4n_2(p_1 - p_2)}{T} + \frac{4n_2^2(p_1 - p_2)^2}{T^2} \right) \right. \\ &\quad \left. - \frac{n_1}{2n_2} + \frac{2n_1n_2(p_1 - p_2)^2}{T^2} \right) \\ &= (1 - \lambda)p_2 \left(Y_{21} - \frac{n_1}{2n_2} + \frac{2n_1n_2(p_1 - p_2)^2}{T^2} \right) \\ &> (1 - \lambda)p_2 \left(Y_{21} - \frac{n_1}{2n_2} \right), \end{aligned}$$

where the third equality follows from rearranging, which allows us to write it in the form of the fourth equality, as in eq. [6] (where 1 replaces A and 2 replaces B).

Finally, we characterize equilibrium when $Y_{12} = 0$ and $Y_{21} = 1$. This is a special case of Case 2. From the first-order conditions, one can solve explicitly for the equilibrium values:

$$n_1 = \sqrt{\frac{\lambda T}{8F_1}}, p_1 = \sqrt{\frac{F_1 T}{2\lambda}}, n_2 = \sqrt{\frac{(2-\lambda)T}{8F_2}}, p_2 = \sqrt{\frac{(2-\lambda)F_2 T}{2\lambda^2}} \text{ and}$$

$$\pi_1 = \pi_2 = (1-\lambda)\sqrt{\frac{(2-\lambda)F_2 T}{2\lambda^2}}.$$

Equilibrium is characterized by $Y_{12} = 0$ if $F_1 > 8F_2$ and

$$\lambda \in \left[\frac{F_1 - 2F_2 - \sqrt{F_1^2 - 8F_1F_2}}{F_1 + F_2}, \frac{F_1 - 2F_2 + \sqrt{F_1^2 - 8F_1F_2}}{F_1 + F_2} \right].$$

Note that all results of Proposition 7 hold: $n_2 > n_1$, $p_1 > p_2$ for $\lambda > \lambda^*$ and $\pi_2 = (1-\lambda)p_2$. ■

Acknowledgement: We thank audiences at WISE, Xiamen University (China), University of Antwerp (Belgium), University of Lille 1 (France) and the North American Summer Meetings of the Econometric Society. We gratefully acknowledge Zhaowei She for his research assistance.

References

- Alexandrov, A.. 2008. "Fat Products." *Journal of Economics & Management Strategy* 17:67–95.
- Anderson, S., and A. J. -L. de Palma. 2006. "Market Performance with Multiproduct Firms." *Journal of Industrial Economics* 54:95–124.
- Bernhardt, D., Q. Liu, and K. Serfes. 2007. "Product Customization." *European Economic Review* 51:1396–422.
- Bernhardt, D., and N. Massoud. 2005. "Endogenous ATM Networks and Pricing." *SSRN eLibrary*.
- Cabral, L. M. B., and J. M. Villas-Boas. 2005. "Bertrand Supertraps." *Management Science* 51:599–613.
- Champsaur, P., and J. C. Rochet. 1989. "Multiproduct Duopolists." *Econometrica* 57:533–57.
- Chen, Y., and M. H. Riordan. 2007. "Price and Variety in the Spokes Model." *Economic Journal* 117:897–921.
- d'Aspremont, C., J. J. Gabszewicz, and J. Thisse. 1979. "On Hotelling's 'Stability in Competition'." *Econometrica* 47:1145–50.
- de Palma, A., V. Ginsburgh, Y. Papageorgiou, and J. F. Thisse. 1985. "The Principle of Minimum Differentiation Holds Under Sufficient Heterogeneity." *Econometrica* 53:767–81.

- Dewan, R., B. Jing, and A. Seidmann. 2000. "Adoption of Internet-Based Product Customization and Pricing Strategies." *Journal of Management Information Systems* 17:9–28.
- Dewan, R., B. Jing, and A. Seidmann. 2003. "Product Customization and Price Competition on the Internet." *Management Science* 49:1055–70.
- Dixit, A. K., and J. E. Stiglitz. 1977. "Monopolistic Competition and Optimum Product Diversity." *American Economic Review* 67:297–308.
- Hotelling, H. 1929. "Stability in Competition." *The Economic Journal* 39:41–57.
- Janssen, M., V. A. Karamychev, and P. van Reeveen. 2005. "Multi-Store Competition: Market Segmentation or Interlacing?" *Regional Science and Urban Economics* 35:700–14.
- Johnson, J. P., and D. P. Myatt. 2006. "Multiproduct Cournot Oligopoly." *RAND Journal of Economics* 37:583–601.
- Klemperer, P. 1992. "Equilibrium Product Lines: Competing Head-to-Head May Be Less Competitive." *American Economic Review* 82:740–55.
- Lancaster, K. 1971. *Consumer Demand; a New Approach*. New York: Columbia University Press.
- Peng, S. -K., and T. Tabuchi. 2007. "Spatial Competition in Variety and Number of Stores." *Journal of Economics & Management Strategy* 16:227–50.
- Reisinger, M. 2006. "Product Bundling and the Correlation of Valuations in Duopoly." Discussion Papers in Economics 477, University of Munich, Department of Economics.
- Salop, S. C. 1979. "Monopolistic Competition with Outside Goods." *The Bell Journal of Economics* 10:141–56.
- Vogel, J. E. 2008. "Spatial Competition with Heterogeneous Firms." *Journal of Political Economy* 116:423–66.
- Yi-Ling, C., S. -K. Peng, and T. Tabuchi. 2011. "Multiproduct Duopoly with Vertical Differentiation." *The B.E. Journal of Theoretical Economics* 11:1–29.