

This is a repository copy of *Reduction of radiated emissions from apertures in resonant enclosures by the use absorptive materials*.

White Rose Research Online URL for this paper:
<http://eprints.whiterose.ac.uk/84203/>

Version: Accepted Version

Proceedings Paper:

Dawson, J.F. orcid.org/0000-0003-4537-9977, Ahmadi, J. and Marvin, A.C. orcid.org/0000-0003-2590-5335 (1992) Reduction of radiated emissions from apertures in resonant enclosures by the use absorptive materials. In: *Electromagnetic Compatibility, 1992.*, Eighth International Conference on. IET , pp. 207-212.

Reuse

Items deposited in White Rose Research Online are protected by copyright, with all rights reserved unless indicated otherwise. They may be downloaded and/or printed for private study, or other acts as permitted by national copyright laws. The publisher or other rights holders may allow further reproduction and re-use of the full text version. This is indicated by the licence information on the White Rose Research Online record for the item.

Takedown

If you consider content in White Rose Research Online to be in breach of UK law, please notify us by emailing eprints@whiterose.ac.uk including the URL of the record and the reason for the withdrawal request.

REDUCTION OF RADIATED EMISSIONS FROM APERTURES IN RESONANT ENCLOSURES BY THE USE ABSORPTIVE MATERIALS

J.F. Dawson, J. Ahmadi, and A.C. Marvin

University of York, UK

ABSTRACT

Preliminary results are presented which show that the radiation from non-resonant (i.e. electrically small) apertures in metallic enclosures is enhanced at the enclosure resonances. It is shown that the levels of radiation at resonance can be significantly reduced by the use of ferrite absorbing tiles or carbon loaded dielectric absorber to damp the enclosure resonances.

A simple equivalent circuit model has been developed which allows prediction of the effects of absorber and slot placement for first order waveguide modes. It is believed that the model can be extended to higher order modes.

INTRODUCTION

Electronic equipment, particularly high speed digital systems, generate significant amounts of high frequency electromagnetic energy. Screened enclosures are used to confine this energy and prevent interference to other systems. Present practice takes no account of the eventual dissipation this energy. Well screened enclosures can act as high-Q cavity resonators. At resonance the internal fields are many times greater than would be generated by the circuits alone (without the enclosure). This leads to increased radiation from apertures which are near field maxima (even when they are electrically small). Enhanced crosstalk between circuits which are near field maxima may also occur.

A program of work is being conducted to examine the feasibility of dissipating this energy within the enclosure by the use of suitably placed absorptive materials. It has been shown that, in the frequency range 30 to 200 MHz, it is possible to dampen the resonances within a screened room using a number of blocks of carbon loaded absorber or ferrite tiles placed at the electric or magnetic field maxima respectively [1,2]. This uses a minimal amount of the relatively expensive absorptive material.

By dissipating the energy within the enclosure it is thought that both crosstalk between circuits and radiation from apertures can be reduced. This paper describes experimental work carried out to demonstrate the reduction in radiation from apertures, by the use of absorptive materials. The paper also shows how a circuit model, using existing microwave circuit theory, can be used to predict the level of radiation from a simple system with and without absorptive materials.

EXPERIMENTAL SYSTEMS

In order to determine the feasibility of the use of dissipative materials in reducing radiation from an aperture in a resonant enclosure, a number of measurements were made using simple, empty enclosures with a single source of excitation.

A large rectangular enclosure (45 x 45 x 90 cm) made of mild steel (Fig. 1) with a small (10.5 x 1.2 cm) rectangular aperture on its face and a small brass enclosure (42 x 36 x 12 cm) with a larger (12 x 3 cm) slot were used for measurements. Only the larger enclosure is considered in this paper due to limitations of space - results of measurements on the smaller enclosure are presented in [3]. In both enclosures the apertures can be closed by means of a brass cover plate secured by close spaced screws.

The circuit within the enclosure is represented by a 9 cm square loop (Fig. 2a). The loop has a 50 Ω load at its centre so that it can be considered as a combination of electric and magnetic dipoles which excite the fields in the enclosure. We consider this to be a more realistic representation of a real circuit than a simple loop or probe since it has both a signal source and a signal load. If this were a circuit connection one would expect the majority of the energy to be passed from source to load with only a small proportion radiated (lost) into the enclosure.

The load in the loop is brought outside the enclosure by making half of the loop a 50 Ω coaxial transmission line as shown in Fig. 2. This allows the energy dissipated in the load to be measured easily.

A simple 4.8 x 4.5 cm square loop of 1mm copper wire, loaded at one end, is also used in some measurements because it does not exhibit the radiation peak that was found with the larger loop allowing the use of a simpler model.

The power lost from the circuit (loop) and the radiated emissions from the enclosures, with and without absorber, were measured. The measurements of power lost from the circuit indicate the degree of interaction between the circuit, the box, and its contents. The radiated emissions measurements indicate the degree of suppression of radiation which can be obtained by the use of absorptive materials.

The absorbers used were Eccosorb FT-01 ferrite tiles and a carbon loaded foam absorber (the highest conductivity layer of AN-79 layered foam absorber) both from Emerson and Cuming. The detailed permeability and permittivity parameters of these absorbers are not available from the manufacturers - they are intended as plane wave absorber and only specified for reflectivity. In the large enclosure 583 cm³ of ferrite tiles 8mm thick were used. The positions of the ferrite and dielectric absorbers are shown in Fig. 3.

Power Lost From the Circuit

In order to ascertain the degree of interaction between the circuit and the enclosure it was decided to compare the power lost (to radiation) from the circuit both within the enclosure and with no enclosure present. The effect of the presence of absorptive material within the enclosure was also considered.

A network analyser was used (Fig. 4) to excite the circuit (loop) and to measure the reflected power from the circuit and the through power to the load. A calculation of power lost by the circuit was made by subtracting the reflected and through power from the forward power. It is assumed that the resistive loss in the material of the circuit (loop) is negligible.

Large enclosure

Fig. 5 shows the proportion of power lost from the circuit (large loop) against frequency for the circuit, on the enclosure lid on an open field test site, and within the enclosure. Calculated enclosure resonances are also marked on the plot. On the lid of the enclosure the loop can be seen to have a self resonant frequency of about 540MHz. It can be seen that the power lost from the circuit is greatly modified by the presence of the enclosure and that most power tends to be coupled from the circuit at the enclosure resonances.

The power lost from the circuit in the enclosure with the slot open was identical to that with the slot closed - the slot was small enough to have little effect on the enclosure resonances.

When ferrite absorber was placed on the walls of the enclosure at the magnetic field maxima for each mode the effect on the energy lost by the circuit was to broaden the peaks indicating a decrease in the Q-factor of the enclosure resonances (Fig. 6) but little change in the proportion of power lost was observed. The results with dielectric absorber are similar.

Figure 7 shows the proportion of power lost from the smaller (4.8 x 4.5 cm) loop. It can be seen that no loop resonance occurs with this loop on the enclosure lid. This loop is used for the equivalent circuit model in order to allow the loop capacitances to be ignored for simplicity. The measurements are near the noise floor of our network analyser and therefore the "power lost" becomes negative in some cases - this occurs when the reflected power is close to 100% which added to the noise in the through

power measurement produces a value greater than the incident power.

Small enclosure

Similar measurements were performed on the small enclosure and a similar set of results were produced [3]. The only significant difference was that presence of the slot has a significant effect on the power lost from the circuit - in this case it represents 0.74% of the surface area compared with 0.06% for the large enclosure. When absorber is added the peak power radiated stays approximately the same but the peaks are greatly broadened and shifted in frequency.

Radiated Emissions

The radiation from the slot was measured on a 3 m open field test site for each enclosure with and without absorber present. Figure 9 shows the radiated field for the large, loaded, loop and Fig. 10 shows the field for the smaller loop. It can be seen that, while the majority of emissions occur at box resonances (mode numbers are marked on the graph) the loop resonance colours the response in Fig 9. In Fig 10 radiation peaks only occur at box resonances - the self-resonant frequency of the small loop is beyond the measurement frequency range. The peaks in field amplitude at resonances are over 20dB greater than the off-resonance levels. When absorber is present (Figs 11 and 12) the box resonances are damped and radiation levels greatly reduced. Fig 12 shows a peak at about 440MHz which appears to be due to the (large) loop resonance. An unexplained peak at about 480 MHz is also present in the measured curve of Fig. 11.

EQUIVALENT CIRCUIT MODELS

Whilst it is possible to use established numerical electromagnetic modelling techniques such as Transmission Line Matrix (TLM) or Finite Difference (FD) methods to determine the fields present within, and external to, the enclosure we decided to use an equivalent circuit model because of the greater computational efficiency and to gain a better understanding of the physical nature of the problem.

A transmission line equivalent circuit model is used to simulate the system for a single (TE₀₁) propagation mode within the box. The use of transmission line based equivalent circuits for prediction of coupling between well separated conductors in a screened enclosure has also been used successfully in [4]. The theory of coupling between small loops and waveguides is covered, to an extent, in the literature [5], as is waveguide propagation [6] and radiation from apertures in waveguide walls. Radiation from slots in the broad face of a waveguide is explained in [7]. For completeness the theory will be outlined here followed by the results for simulation of the TE₀₁ modes in the large enclosure. We believe it is possible to extend the method to higher order modes (as in [4]).

Description of the Model Used

The circuit model used to analyse the system of Fig. 1 is shown in Fig. 8. The waveguide formed by the sides of the enclosure is represented by a transmission line - only propagation in the TE₀₁ mode is considered here. The two end walls of the enclosure are treated as short circuits at either end of the transmission line. Currently the waveguide losses are assumed negligible and the reflection coefficient at either end wall is assumed to be that of an ideal short-circuit (-1). The magnetic field generated by the loop couples into the waveguide and can excite any mode which has a (non-zero) magnetic field component parallel to the axis of the loop and within the area of the loop. This is represented as a mutual inductance coupling into the end wall of the enclosure (i.e. the short circuit end is replaced by an inductance coupled to the loop inductance). Dielectric losses can be represented by placing a parallel (lossy) admittance in the transmission line and magnetic losses can be represented by inserting a series (lossy) impedance in the line. Apertures in the enclosure may appear as series or shunt elements depending upon which face of the enclosure they fall. In this paper we deal exclusively with a slot on the face of the waveguide which is perpendicular to the electric field component - this appears as a series impedance since it interacts most strongly with the magnetic field within the guide.

Transmission line analogy

The voltage $V(z)$ and current $I(z)$ on the transmission line represent the TE₀₁ electric and magnetic fields in the waveguide such that:

$$E_x = \frac{V(z)}{b} \sin \frac{\pi}{a} y \quad (1)$$

$$H_y = \frac{2I(z)}{a} \sin \frac{\pi}{a} y \quad (2)$$

where b and a are the size of the guide (enclosure) in the x and y directions respectively. To facilitate this the line and guide impedances are both defined as:

$$\frac{V}{I} = Z_g = 2 \frac{b}{a} \sqrt{\mu/\epsilon} \frac{\lambda_g}{\lambda_0} \quad (3)$$

where λ_0 and λ_g are the wavelengths in free-space and in the guide respectively.

Coupling of loop to guide

In order to describe the coupling of the loop into the enclosure we must quantify its self-inductance L_L and its coupling to the TE₀₁ waveguide mode in the enclosure. The simplest model is to consider a mutual inductance M which determines the emf induced in the end wall of the enclosure for a given loop current and vice-versa. The wall inductance L_W shown in Fig. 8 is implicitly zero by the assumption of a -1 reflection coefficient. Note that this inductance does not have to have a non-zero value for the circuit model to be valid.

The self-inductance of a square loop, side D , of wire, radius r is given in [8] as:

$$L = \frac{2\mu D}{\pi} \left[\ln \left(\frac{D + \sqrt{D^2 + r^2}}{r} \right) - 1 \right] \quad \text{Henry} \quad (4)$$

The fact that only the H_y component of the field inside the enclosure couples to the loop can be exploited to find M . Assuming constant H_y over the plane of the loop, the flux, Φ , cutting through the plane of the loop is:

$$\Phi = \mu H_y A \quad (5)$$

where A is the loop area and the spatial variation of H_y is given by (2). The emf induced in the loop for a given H_y is:

$$E_L = -j\omega \Phi \quad (6)$$

where ω is the angular frequency. Combining (5) and (6) and (2) we get the emf induced in the loop in terms of the transmission line current:

$$E_L = -j\omega \mu A \frac{2I(0)}{a} \sin \frac{\pi}{a} y \quad (7)$$

where y is the position of the loop in the guide and $I(0)$ is the current at the end of the guide where the loop is placed. From the circuit analogy

$$E_L = -j\omega M I(0) \quad (8)$$

Equating terms in (7) and (8) we get:

$$M = \mu A \frac{2}{a} \sin \frac{\pi}{a} y \quad (9)$$

With the loop placed centrally, as in Fig. 1, (9) reduces to

$$M = \mu A \frac{2}{a} \quad (10)$$

The slot

The slot is represented as a series impedance using the expressions derived by Oliner [7], which can be used to represent a rectangular slot of arbitrary size and orientation in the face of a waveguide perpendicular to the Electric field of the TE₀₁ mode propagating in the guide. The expressions are valid both at and away from slot resonances and include the effect of finite wall thickness.

The power radiated by the slot can be calculated by solving the equivalent circuit (Fig. 8) to determine the current flowing in the slot impedance and hence the power dissipated in its real part.

The power radiated by the slot can be calculated by solving the equivalent circuit (Fig. 8) to determine the current flowing in the slot impedance and hence the power dissipated in its real part.

Radiated field

In this paper the simplistic assumption that the slot was an isotropic radiator was used to determine the electric field at 3 metres (the measurement distance). No correction was made for the presence of the ground plane on the open field site where the measurements were taken. Cable losses and the antenna factor of the log-periodic antenna used were allowed for in the measured curves.

Absorber

Ferrite absorber, which interacts strongly with the magnetic fields, can be simulated in the model by placing series loss elements in the transmission line whilst lossy dielectrics, which interact strongly with the electric field, can be simulated by placing shunt loss elements across the transmission line. Both are shown in Fig. 8. The lossy elements should be placed at current or voltage maxima for each line resonance to achieve the greatest effect. The loss in the series elements is proportional to the square of the current flowing (H field) and the loss in the parallel elements is proportional to the square of the voltage (E field) so greatest energy is dissipated by a given element when placed at a current or voltage maximum on the transmission line. For simple systems the positions of current and voltage maxima on the transmission line (and for the fields in the box) can be determined easily using simple transmission line (waveguide) theory. For more complex problems the positions of the field maxima must be determined by using the circuit model in an unloaded state and monitoring the voltages and currents on the line. Alternatively the full 3-dimensional system can be modelled using TLM or FD techniques.

Results From the Model

The large enclosure with a slot, and both loops have been modelled with and without absorber. Fig 9 shows the measured and simulated results for the large loop with no absorber. Here the model used is inadequate because the loop resonance effects the results significantly.

Fig. 10 shows the same comparison with the smaller loop. Here the model predicts accurately all of the resonance peaks due to the TE₀₁ mode resonances (those simulated).

Fig. 11 shows the measured and predicted radiated fields for the small loop with carbon loaded foam dielectric absorber. An additional peak appears at about 480 MHz in the measured results. The simulation used 3.7 kΩ loads at 1/4, 3/8, and 1/2 of the line length from the short circuit end. These positions should cover at least one voltage (E-field) maxima for each resonant mode. Fig 12 again shows the inadequacy of the model for the resonant large loop.

Fig. 13 shows the effect of varying the load resistances in the simulation, it can be seen that significant damping can be achieved with relatively high load resistances.

Fig. 14 shows the effect of removing the load at 3/8 of the line length from the shorted end. It can be seen that the 4th resonance is not damped at all as it has no voltage maxima at either of the remaining loads.

CONCLUDING REMARKS

Experimental Results

It can be seen from the experimental results that the highest levels of radiated fields occur at the enclosure resonant frequencies. Resonances in internal structures can colour this response to some extent.

The presence of lossy materials at the field maxima can effectively damp enclosure resonances reducing the peak radiated fields by about 20dB.

Circuit Model

A simple circuit model has been presented which can predict the levels of radiation from apertures in the enclosure for simple loop excitation, including the effects of damping materials. Inclusion of the loop capacitances to correctly simulate the loop resonances should be possible. The model may be extended to cover higher order modes of propagation, as outlined in [4], and more complex circuits within the enclosure. It seems likely that an alternative numerical method (TLM or FD) may be required to accurately model the fields within more complex systems - i.e. complex enclosure geometries and/or complex circuit cards. The great advantage of the equivalent circuit approach is that for simple systems the results can be computed in minutes with modest memory requirements rather than days as required for TLM or similar packages.

Further work

The main objectives of the research programme are to develop methods of reducing radiated emissions from, and crosstalk between, electronic circuits within imperfectly screened enclosures using absorptive materials. To this end we wish to be able to determine the type, placement, and effectiveness of absorptive material for any particular system.

Further work is required to develop models of more complicated structures within the enclosure if real electronic systems are to be simulated. It seems likely that a more conventional numerical method (TLM or FD) will be required to determine the radiation from and fields within complex structures. It is likely that advances in these modelling techniques will be required if accurate predictions are to be made for complete systems. However, it may be possible to predict the internal field distribution in complex systems sufficiently accurately to determine the placement of absorptive materials by using simplified models of the real system so that radiated emissions can be reduced. Also work is required in more accurately modelling the parameters of the absorptive materials - the use of fixed resistances is very approximate.

REFERENCES

- 1 DAWSON L & MARVIN A C, Jan 1988, "New Screened Room Techniques for the Measurement of RFI", *JIERE*, Vol 58 No 1.
- 2 DAWSON L & MARVIN A C, Sept 1988, "Alternative methods of damping resonances in a screened room in the frequency range 30 to 200 MHz", Proc. 6th IERE Conference on EMC, York, No 81.
- 3 J. F. Dawson, J. Ahmadi, and A. C. Marvin, 17th Jan 1992, "Reduction of Radiated Emissions from Apertures in Resonant Enclosures by the Use of Lossy Materials", IEE Colloquium on "Screening of connectors, cables and enclosures", Digest No: 1992/012 pp3/1-3/4
- 4 RENDER M.C. & MARVIN A.C., Sept 1992, "Cross-talk between conductors in screened environments", Proc 8th IEE Conference on EMC, Edinburgh
- 5 R.E. COLLIN, 1966, "Foundations for Microwave Engineering", McGraw Hill, pp187-190 & pp336-337
- 6 H MOOIJWEER, 1971, "Microwave Techniques", Macmillan, Ch13-14
- 7 ARTHUR A. OLINER, Jan. 1957, "The impedance Properties of Narrow Radiating slots in the Broad Face of Rectangular waveguide", *IRE Transactions on Antenna and Propagation*, vol. AP-5, PP. 4-20
- 8 MARKUS ZAHN, 1979, "Electromagnetic field theory", Malabar, Florida, Robert E. Krieger, p343

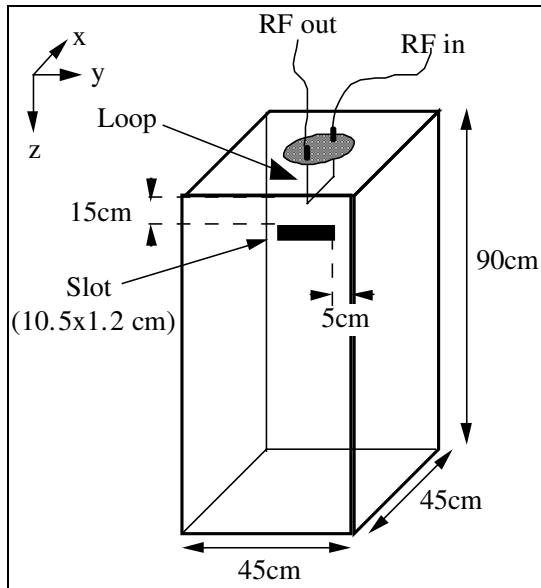

Fig. 1 Large enclosure showing loop, slot and orientation of axes

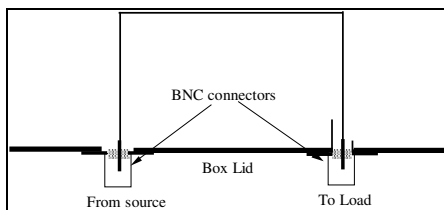

Fig. 2a Detail of the small wire loop

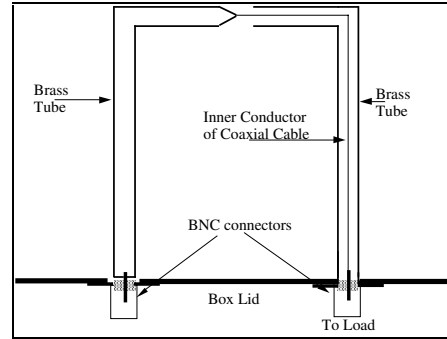

Fig 2b Detail of the large loaded loop

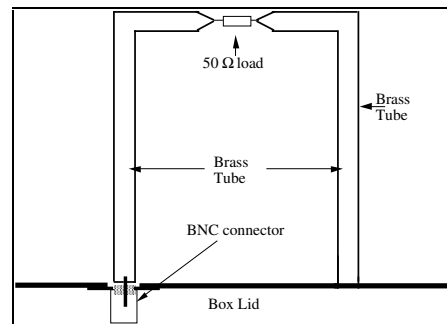

Fig. 2c Equivalent loaded loop

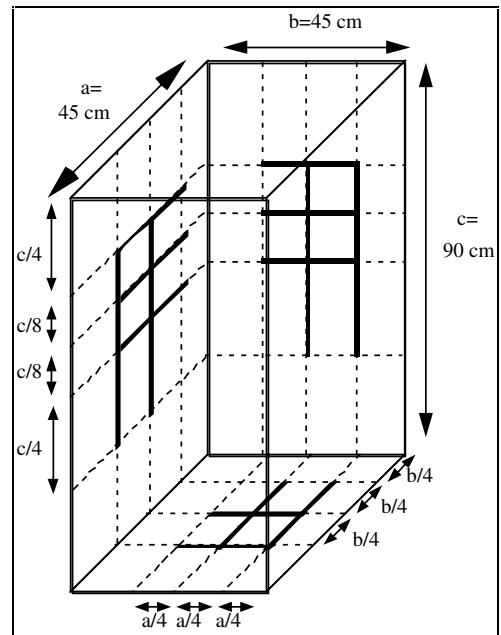

Fig. 3a Placement of ferrite absorber on enclosure walls

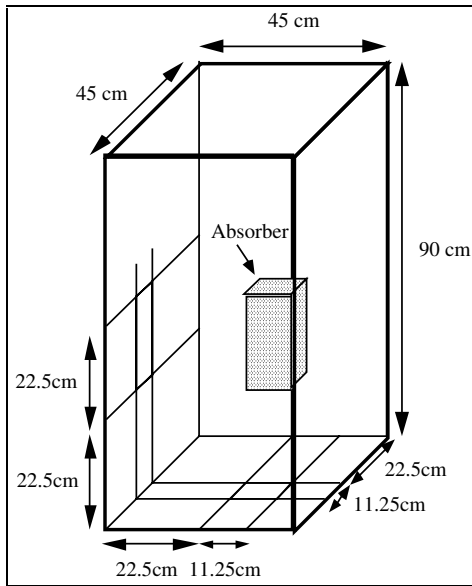

Fig. 3b Placement of dielectric absorber in enclosure

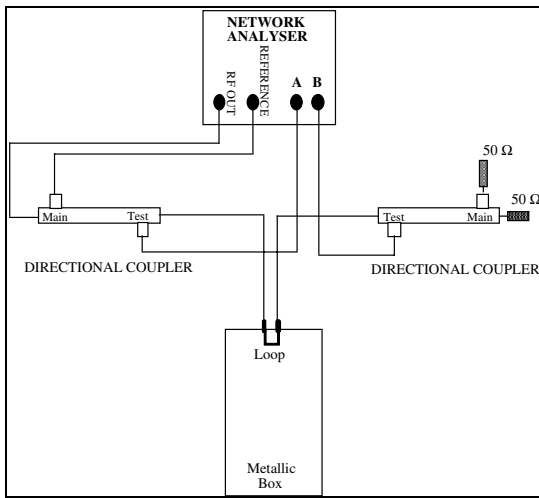

Fig. 4 Measurement of Power lost from circuit (loop)

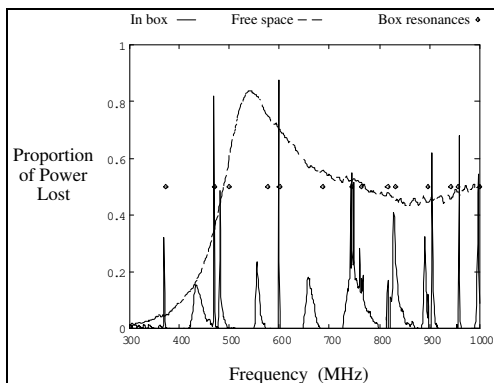

Fig. 5 Power lost from circuit in free space (on enclosure lid) and in large enclosure (no absorber)

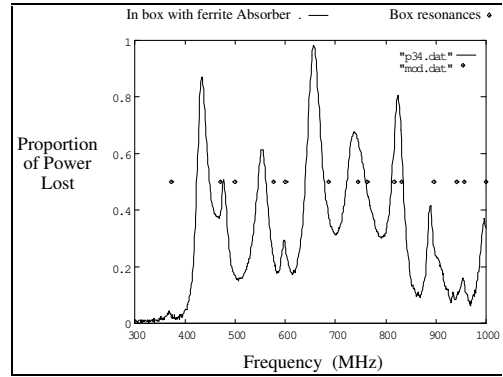

Fig. 6 Proportion of power lost from circuit in large enclosure with ferrite absorber

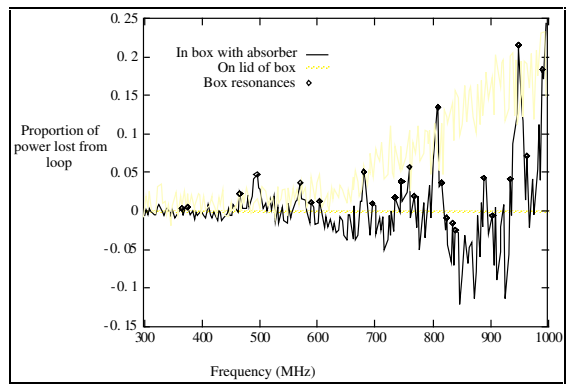

Fig. 7 Proportion of power lost from a small (4.8 x 4.5 cm) loop on the enclosure lid and in the enclosure with absorber

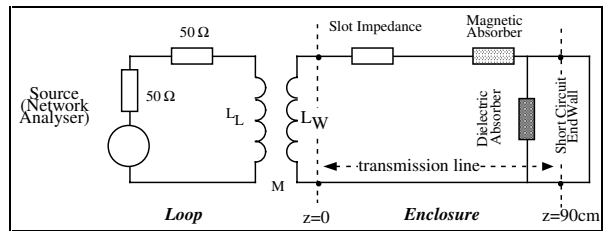

Fig. 8 Transmission line equivalent circuit of loop, in box, with slot and (optional) magnetic or electric field absorber (placement of absorber not shown)

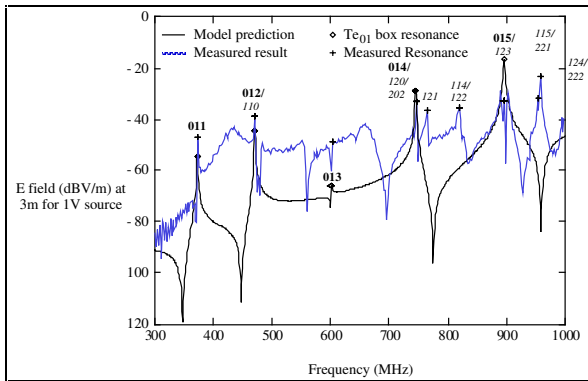

Fig. 9 Comparison of measured and predicted radiation from slot in large enclosure with large (9 x 9 cm) loaded loop

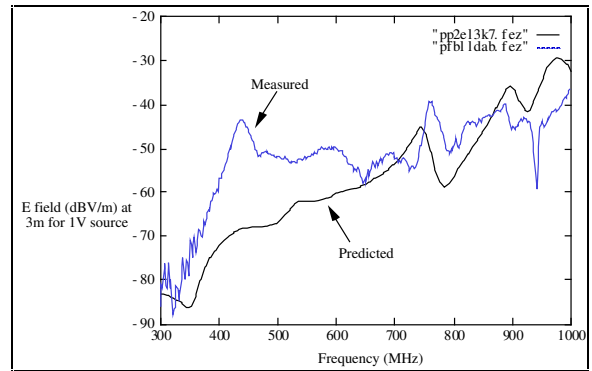

Fig. 12 Comparison of measured and predicted radiated field from slot in enclosure with dielectric absorber (large loop)

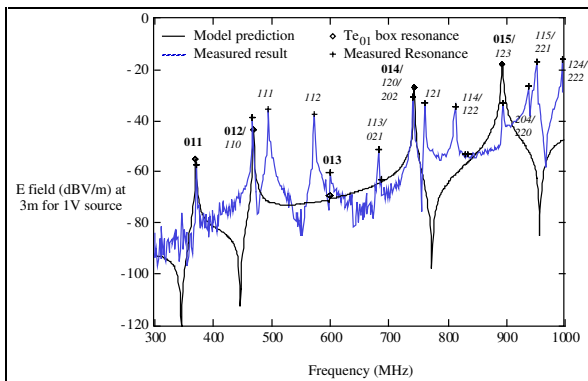

Fig. 10 Comparison of measured and predicted radiation from slot in large enclosure with small (4.8 x 4.5 cm) loop

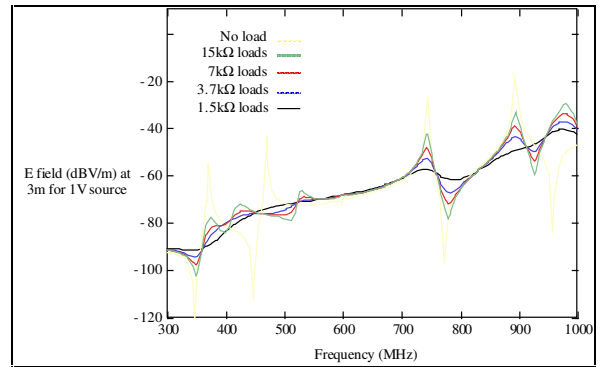

Fig. 13 Effect of reducing load resistance on damping of resonance (predicted)

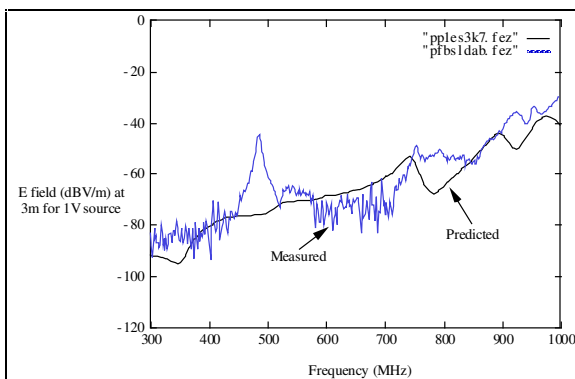

Fig. 11 Comparison of measured and predicted radiated field from slot in enclosure with dielectric absorber (small loop)

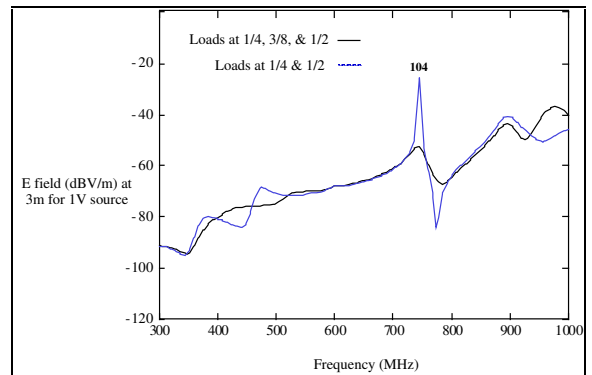

Fig. 14 Effect of failing to load a resonance effectively