



## Strathprints Institutional Repository

**Melone, Joseph and Zafar, Jawwad and Coffele, Federico and Dysko, Adam and Burt, Graeme M. (2015) A model-based analysis method for evaluating the grid impact of EV and high harmonic content sources. International Journal of Distributed Energy Resources, 11 (4). 99 - 110. ISSN 1614-7138 ,**

This version is available at <http://strathprints.strath.ac.uk/56980/>

**Strathprints** is designed to allow users to access the research output of the University of Strathclyde. Unless otherwise explicitly stated on the manuscript, Copyright © and Moral Rights for the papers on this site are retained by the individual authors and/or other copyright owners. Please check the manuscript for details of any other licences that may have been applied. You may not engage in further distribution of the material for any profitmaking activities or any commercial gain. You may freely distribute both the url (<http://strathprints.strath.ac.uk/>) and the content of this paper for research or private study, educational, or not-for-profit purposes without prior permission or charge.

Any correspondence concerning this service should be sent to Strathprints administrator: [strathprints@strath.ac.uk](mailto:strathprints@strath.ac.uk)

# **A MODEL-BASED ANALYSIS METHOD FOR EVALUATING THE GRID IMPACT OF EV AND HIGH HARMONIC CONTENT SOURCES**

*Joseph Melone, Jawwad Zafar, Federico Coffele, Adam Dyško, Graeme M. Burt  
Power Networks Demonstration Centre  
University of Strathclyde  
62 Napier Road, Wardpark, Cumbenauld, G68 0EF, UK  
Phone +44(0)1236 617161  
E-mail: joseph.melone@strath.ac.uk*

*Keywords:* FFT; Harmonic Measurement; Inductive Charger impact; LV-grid; Power Quality Measurement;

## **ABSTRACT**

The impact on the distribution grid when Electric Vehicles are connected is an important technical question in the development of new smart grids. This paper looks in detail at the predictive capability of a model, calculating harmonic voltage and current levels, in the situation where an electric vehicle is being charged by an inductive charging plate which acts as a substantial source of harmonic distortion. The method described in this paper models distortion at the LV side of the distribution grid by reconstructing the HV harmonic distortion levels seen at a typical LV substation. Additional LV connected harmonic-rich current sources can then be added, allowing a quantitative analysis of the impact of such sources on the distribution grid in terms of measurable harmonics magnitude and phase angle with respect to the fundamental.

## 1 INTRODUCTION

The adoption of electric vehicles (EVs) for decarbonisation of transport is gathering pace. Manufacturers of EVs as well as charging equipment are proposing new technology while standardisation efforts across the supply chain are being undertaken. The integration of electric vehicle supply equipment (EVSE) into the electricity network has several aspects such as increased load on the system, power quality concerns, business models for ownership of infrastructure, secure monetary transactions for electrical energy used in vehicle charging and participation in demand-side response, all in the back-drop of future smarter grids.

The EVs utilise power-electronic hardware to interface with the grid. As such, the assessment of consequences for power quality on the network becomes important. The current drawn by EVs connected to the grid has harmonics, which distort the voltage waveform at the point of common coupling (PCC) and beyond. The distortion of the voltage depends is normally more important when the fault level at the PCC is low [1].

In order to provide a measure of the distortion in current and voltage caused by the harmonics, indices such as the total harmonic distortion (THD). Guidance on THD limits is provided in the relevant standards and engineering recommendations such as ER G5/4-1 [2], which prescribes the planning level at different voltages (for the United Kingdom) for example a maximum of 4% at 11 kV and 5% at 400 V [1]. Limits for harmonic currents emission by equipment connected to public low-voltage system is set out in BS EN 61000-3-2 [3], BS EN 61000-3-12 [4] and ER G5/4-1.

Under Stage 2 of ER G5/4-1, an assessment of background harmonic voltage may be required before the low-voltage (LV) non-linear load, which falls outside the Stage 1 assessment due to its higher power rating or harmonic current emissions, is allowed to be connected. A measurement period of at least 7 days is advised and voltage assessment is to be made at low voltage. Harmonics up to and including the 50<sup>th</sup> are required to be used for calculation of THD. Mitigation measures are necessary where the predicted 5th harmonic and voltage THD values fall outside limits as defined in Table 1 below from [2].

**Table 1: Planning Levels for Harmonic Voltages in 400V Systems.**

Odd harmonics (Non-multiples of 3)		Odd harmonics (Multiples of 3)		Even harmonics	
Order 'h'	Harmonic Voltage (%)	Order 'h'	Harmonic Voltage (%)	Order 'h'	Harmonic Voltage (%)
5	4.0	3	4.0	2	1.6
7	3.0	9	1.2	4	1.0
11	3.0	15	0.3	6	0.5
13	2.5	21	0.2	8	0.4
17	1.6			10	0.4

**Table 2: Maximum Permissible Harmonic Current Emissions in Amperes RMS for Aggregate Loads and Equipment Rated > 16A per phase.**

Harmonic Order, h	Emission current, $I_h$	Harmonic Order, h	Emission current, $I_h$
2	28.9	13	27.8
3	48.1	14	2.1
4	9.0	15	1.4
5	28.9	16	1.8
6	3.0	17	13.6
7	41.2	18	0.8
8	7.2	19	9.1
9	9.6	20	1.4
10	5.8	21	0.7
11	39.4	22	1.3
12	1.2	23	7.5

For this piece of work, it is assumed that the LV wireless fast charger has a per-phase current greater than 16 A with harmonic currents larger than those specified in Table 2 from [2] and therefore will need an assessment of background distortion. This paper extends the simulation based analysis method of benchmarking existing harmonics, discussed in [1], at a point in the network which can be other than the PCC.

Several studies found in literature have addressed the impact of power-electronic interfaced equipment on LV networks. Amongst them, [5, 6, 7, 8] can be referred to.

## 2 NETWORK DETAILS AND MEASUREMENT OF EXISTING DISTORTION

The network topology used for the implementation of the model-based analysis method is shown in Figure 1 below, which is based on a part of the distribution network in central Glasgow. The modelled network consists of an 11 kV and an LV network with fault levels of 250 MVA and 25 MVA, respectively. The LV network is composed of four feeders fed by the distribution substation (S/S) F. One of the four feeders supply the inductive wireless charger, while the other three feeders supply a mix of load which is largely residential and commercial.

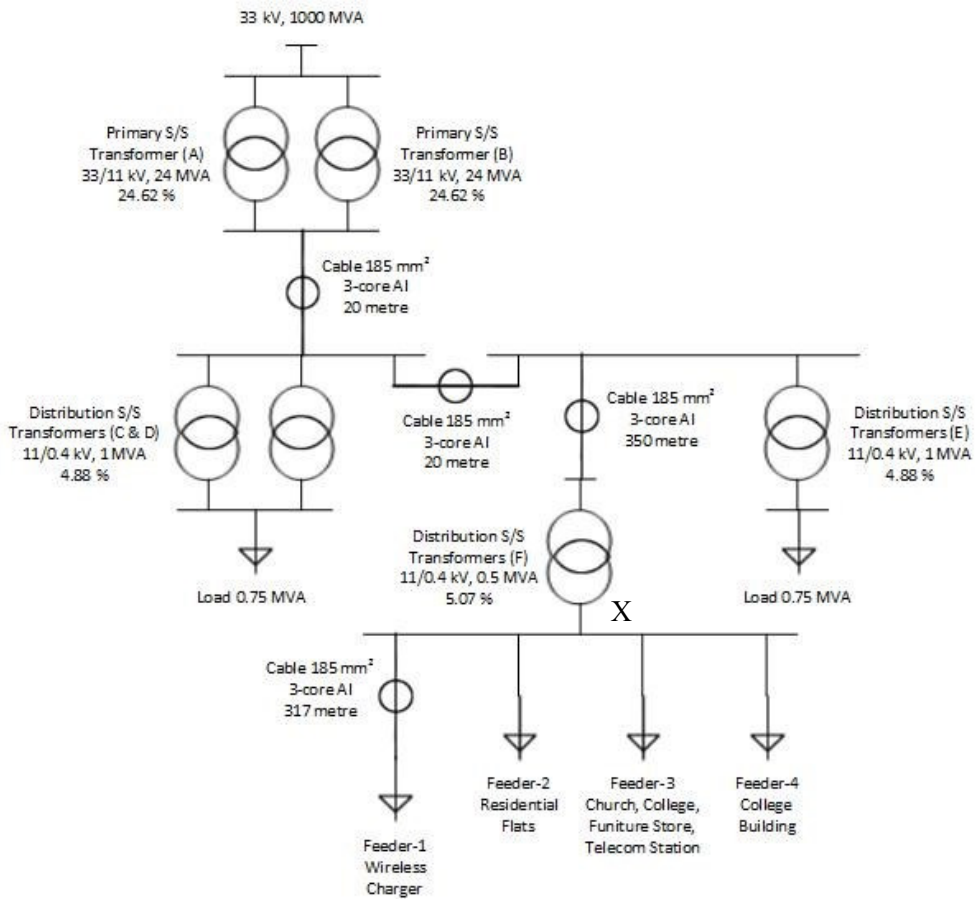

**Figure 1:** Network schematic used in simulation model.

The electrical data for the transformers is provided in Table 3 while Table 4 lists cable parameters.

**Table 3: Network transformer details**

<i>Transformer</i>	<i>Voltage</i>	<i>Power</i>	<i>Impedance</i>
<i>Type Identifier</i>	<i>[kV]</i>	<i>[MVA]</i>	<i>[%]</i>
Primary A, B	33/11	12/24	24.62
Distribution C, D, E	11/0.4	1	4.88
Distribution F	11/0.4	0.5	5.07

**Table 4: Characteristics of the 3-core Aluminium cable modelled in simulation**

<i>Cross-section</i>	<i>Resistance</i>	<i>Inductance</i>	<i>Capacitance</i>
<i>[mm<sup>2</sup>]</i>	<i>[<math>\Omega</math>/km]</i>	<i>[H/km]</i>	<i>[F/km]</i>
185	$2.11 \times 10^{-1}$	$3.30 \times 10^{-4}$	$3.60 \times 10^{-7}$

### 3 METHOD

The network shown in Figure 1 is modelled in SIMULINK using standard transformer blocks and 3-phase PI sections to simulate conductor lengths between the transformers and measurement point. When the properties of the physical network have been adequately represented, the next stage is to attempt to recreate a real physical measurement taken at point X with an Outram Power Quality Analyser [9]. This is done by simulating the model with a HV supply at fundamental frequency and additional sources of voltage harmonics and current harmonics, which can be tuned to match the observed distortion at the measurement point. The method by which the distortion can be retrospectively added to the model has been described in a previous publication [1]. This involves calculating the magnitude and phase shift induced by the network components, in a harmonic source voltage and current, where these parameters are known. The difference between the harmonic source and what is seen at the measurement point is a complex quantity representing the magnitude and phase difference. Therefore, the ratio between the source values and the measurement point values for each harmonics considered in this study can be defined as a set of complex coefficients, which transform the harmonic source values to the measurement point values, and vice versa. In short, the method aims to use the SIMULINK model to first establish these coefficients in the most effective manner possible and then use them on a measured waveform in order to create the harmonic voltage and current sources necessary to reconstruct the measurement. The benefit of using this approach is that another harmonic source can be added at any point in the network and by the principle of wave superposition, its effect can be accurately modelled at the measurement points in the SIMULINK model.

#### 3.1 SIMULINK

Standard SIMULINK/SimPowerSystems blocks are used to model the distribution system in Figure 1 with its step-down transformers. On the LV side of S/S F there is a measurement point X, implemented using standard signal measurement blocks, where the feeder currents are summed together. Since in reality the measurement of harmonic data is done at bus-bar level in this system, therefore the feeder power levels have been summed.

### 3.2 Complex amplitude transfer coefficients

The modification made here to the method previously proposed in [1] for calculating the complex transfer coefficients is to automate the process using fast Fourier transform (FFT) analysis. Harmonic frequency components of a waveform are a complex quantity with a magnitude and phase. Therefore, the ratio of the measured harmonic signal to the harmonic input source at the same frequency, defines the transfer coefficient, which is the same complex quantity described in [1].

$$I_{Dh} = a_{iih}I_{Sh} + a_{ivh}V_{Sh} \quad (1)$$

$$V_{Dh} = a_{vih}I_{Sh} + a_{vvh}V_{Sh} \quad (2)$$

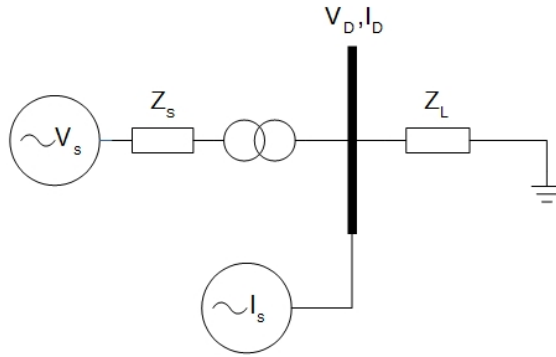

**Figure 2:** Definition of the voltage and current quantities in the network.

This is defined in equations (1) and (2), where the subscript D indicates a measured quantity,  $h$  denotes a particular harmonic frequency,  $S$  corresponds to a harmonic source,  $a$  is a complex transfer coefficient with its subscript indicating that it represents the relationship between corresponding measured quantity (first letter) and source quantity (second letter). For example,  $a_{iih}$  is a complex number representing the ratio between the measured current and source current at a particular harmonic frequency  $h$ . One can also see from equations (1) and (2) that there is an interdependence between voltage and current measurements and their harmonic sources.

### 3.3 Coefficient Determination

Since the measurement point voltage and current are dependent on the harmonic voltage and current sources  $V_s$  and  $I_s$ , the simplest method to determine coefficients



is to perform two simulations. Firstly with  $V_s = 0$ , this simulation allows the calculation of  $a_{iih}$  and  $a_{vih}$  from equations (1) and (2) directly. Then with  $I_s = 0$ , the same calculation returns  $a_{vvh}$  and  $a_{ivh}$ .

A separate FFT analysis of the harmonic source and measurement point waveforms created by the SIMULINK model, allows the ratio of the FFT complex-valued output arrays created by the FFT MATLAB function to be used for calculating the coefficient values over the entire frequency range of the FFT array.

Therefore, at harmonic frequency  $h$  and with  $V_s = 0$ , the coefficient  $a_{iih}$  can be calculated as:

$$a_{iih} = \mathbf{FFT}(i_{Dh})/\mathbf{FFT}(i_{Sh}) \quad (3)$$

#### 4 RESULTS

To demonstrate the method, the simulation model was run using a set of harmonics with equal magnitudes to allow the calculation of the coefficients. Following this, the coefficients are used on the measured data to calculate the harmonic voltage and current sources that would be needed to reproduce this measurement in the model. Then an extra 3-phase harmonic source is introduced at the LV side of the model, imitating the effect of an inductive charger used for wireless charging of electric vehicles in this case.

Figure 3 below shows the measured voltage waveform for one phase at the measurement point, and the modelled waveform is also shown for comparison.

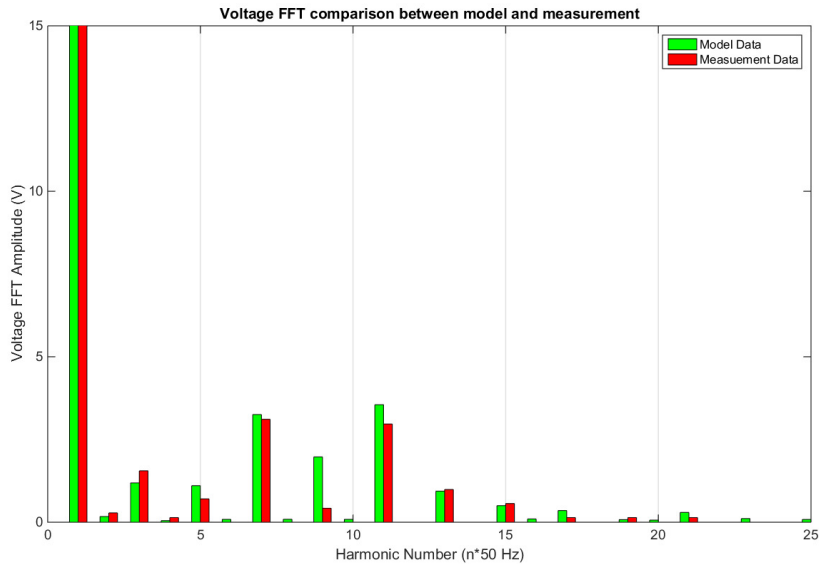

**Figure 3:** Comparison of the measured and reconstructed voltage at the measurement point. The triplen harmonics of 9 and 21 show a significant disagreement from measurement, and investigation of this will be part of further investigations in the future.

Figure 4 shows the harmonic voltage source waveform which was created using the process described in Section 3. This waveform is superimposed on the 33kV fundamental sine wave to generate the high-voltage input which recreates the conditions at the measurement point.

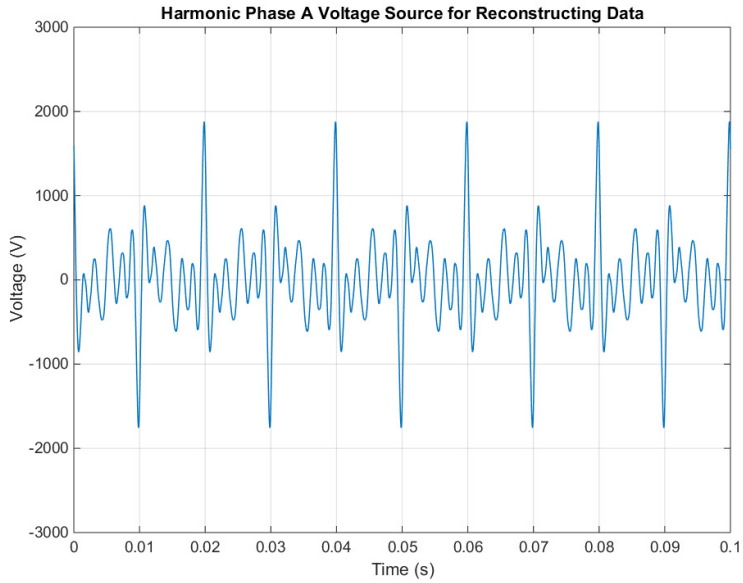

**Figure 4:** Harmonic Voltage source used to recreate the measured LV quantities.

Figure 5 shows the harmonic components of the real current measurement and the modelled values.

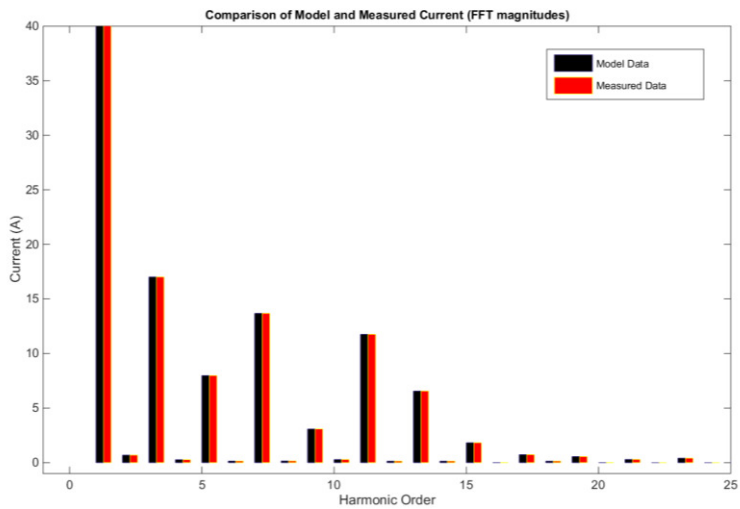

**Figure 5:** A comparison of the harmonic current components measured by the Outram Power Quality Analyser and recreated by the model at the measurement point.

The important result here is the comparison in Table 5 showing the comparison in LV voltage THD value between the measured values and the reconstructed values. The error between measurement and model here is ~0.2%.

**Table 5: Results comparing measured harmonic parameters and the model results on phase A.**

	LV Voltage THD	LV Current THD
Measurement Data	1.39%	8.0%
Modelled Data	1.56%	8.4%
Difference	0.17%	0.4%
Modelled Data with Inductive Charger	5.30%	20.4%
Difference between modelled data and model including inductive charger	3.74%	12.0%

After injecting the distorted waveform associated with the inductive charger into the model, Table 5 also shows the observed increase in voltage and current THD at the model measurement point.

It can be seen that the inductive charger causes a large increase in the LV Voltage THD as observed at the measurement point.

The modelled increase in THD of the LV voltage supply actually exceeds the specified limits of the G5/4-1 recommendations here, and since the agreement between model and measurement is fairly good, it is possible to identify the main source of this extra distortion.

Figure 6 shows the inductive charger harmonic components, where the 5<sup>th</sup> harmonic component of the current has been deliberately set at a very high level in order to establish the limit in this network configuration where the guideline THD limit would be exceeded. The total THD of the current signal injected by the Inductive Charger which exceeds the G5/4-1 limits is modelled here to be in excess of 66%.

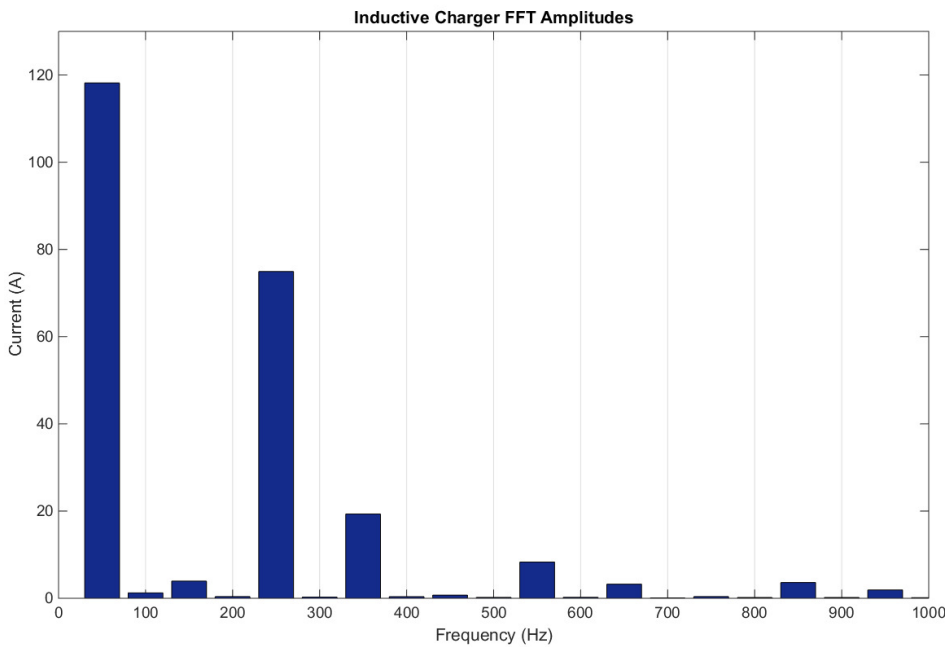

*Figure 6: FFT analysis of the Inductive Charger harmonic current components which are injected into the model.*

## 5 CONCLUSION

This paper demonstrates the potential of an extension to the method described in [1] for approaching a synthetic reconstruction of harmonic sources present in a power network, which allows the use of modelling software like SIMULINK to calculate the impact on the network from adding other sources of harmonic distortion.

A method has been demonstrated which builds upon previous work to automate the creation of a table of coefficients which allows the recreation of distorted voltage and current from real network data.

The results section shows an agreement of 10% for the voltage reconstruction and 5% for the current reconstruction between the model and the measured data. This is the platform for adding in other sources of distortion in the model and gaining predictive power for the network conditions occurring when a source of distortion such as an inductive charger for EVs is connected to the distribution system.

This method is aimed at analysing the grid compliance and network effect of the expected surge in distributed generation and electric vehicles in the future development of smart grids.

## 6 FUTURE WORK

It has been observed that the attenuation of the triple harmonics ( $h=3, 9, 15\dots$ ) which is expected in a delta-star transformer, is not properly represented in this SIMULINK model. This does not significantly affect the calculation of THD shown in Table 5, however this issue will be investigated in detail in future applications of this model. Extending the scope of the case study for different network configurations and a variety of transformer will also be a priority in future model applications

## 7 REFERENCES

- [1] A. Dysko, G. Burt, J. McDonald and J. Clark, "Synthesis of Harmonic Distortion Levels in an LV Distribution Network," *IEEE Power Engineering Review*, vol. 21, no. 5, pp. 58-60, 2001.
- [2] G5/4-1, Engineering Recommendation, *Planning Levels For Harminc Voltage Distortion And The COnnection Of Non-Linear Equipment To Transmission Systems And Distribution Networks In The UK*, Energy Networks Association, 2005.
- [3] BS EN 61000-3-2:2006+A2:2009, *Part 3.2: Limits for harmonic current emissions (equipment input current  $\leq 16A$  per phase)*, British Standards Institution, 2006.
- [4] BS EN 61000-3-12:2005, *Part 3-12: Limits for harmonic currents produced by equipment connected to public low-voltage systems with input current  $>16 A$  and  $<75 A$  per phase*, British Standards Institution, 2005.
- [5] A. Dysko, G. Burt and J. McDonald, "Assessment of Harmonic Distortion Levels in LV Networks With Increasing Penetration Levels Of Inverter Connected Embedded Generation," in *CIREN, 18th International Conference on Electricity Distribution*, Turin, 2005.
- [6] I. Santos and V. e. a. Cuk, "Considerations on hosting capacity for harmonic distortions on transmission and distribution systems," *Electric Power Systems Research*, vol. 119, no. February, pp. 199-206, 2015.
- [7] D. Tofilovic and N. Rajakovic, "The simultaneous impact of photovoltaic systems and plug-in electric vehicles on the daily load and voltage profiles and

the harmonic voltage distortions in urban distribution systems,” *Renewable Energy*, vol. 76, no. April, pp. 454-464, 2015.

[8] K. McBee and M. Simoes, “Evaluating the Long-Term Impact of a Continuously Increasing Harmonic Demand on Feeder-Level Voltage Distortion,” *IEEE Transactions on Industry Applications*, vol. 50, no. 3, pp. 2142-2149, 2014.

[9] J. Berry, S. Jupe, M. Meisinger and J. Outram, “Implementation of an Active Fault Level Monitoring System for Distributed Generation Integration,” in *CIREN 22nd Int. Conf. on Electricity Distribution*, Stockholm, 2013.