



Strathprints Institutional Repository

Lemieux, Andrée-Ann and Jeukens, Julie and Kukavica-Ibrulj, Irena and Fothergill, Joanne L. and Boyle, Brian and Laroche, Jérôme and Tucker, Nicholas P. and Winstanley, Craig and Levesque, Roger C. (2016) Genes required for free phage production are essential for pseudomonas aeruginosa chronic lung infections. Journal of Infectious Diseases, 213 (3). pp. 395-402. ISSN 0022-1899 , <http://dx.doi.org/10.1093/infdis/jiv415>

This version is available at <http://strathprints.strath.ac.uk/55871/>

Strathprints is designed to allow users to access the research output of the University of Strathclyde. Unless otherwise explicitly stated on the manuscript, Copyright © and Moral Rights for the papers on this site are retained by the individual authors and/or other copyright owners. Please check the manuscript for details of any other licences that may have been applied. You may not engage in further distribution of the material for any profitmaking activities or any commercial gain. You may freely distribute both the url (<http://strathprints.strath.ac.uk/>) and the content of this paper for research or private study, educational, or not-for-profit purposes without prior permission or charge.

Any correspondence concerning this service should be sent to Strathprints administrator: strathprints@strath.ac.uk

Genes Required for Free Phage Production are Essential for *Pseudomonas aeruginosa* Chronic Lung Infections

Andrée-Ann Lemieux^{1,*}, Julie Jeukens^{1,*}, Irena Kukavica-Ibrulj^{1,*}, Joanne L. Fothergill^{2,*}, Brian Boyle¹, Jérôme Laroche¹, Nicholas P. Tucker⁴, Craig Winstanley² and Roger C. Levesque^{1,}**

¹Institut de biologie intégrative et des systèmes (IBIS), Université Laval, Québec, Canada

²Institute of Infection and Global Health, University of Liverpool, Liverpool, United Kingdom

³Centre INRS-Institut Armand-Frappier, Laval, Québec, Canada

⁴Institute of Pharmacy and Biomedical Sciences, University of Strathclyde, Glasgow, Scotland, UK

*These authors contributed equally to this work.

**Corresponding Author Details: Professor Roger C. Levesque, Institut de biologie intégrative et des systèmes (IBIS), Université Laval, 1030 avenue de la médecine, Québec, G1E 7A9, Canada, rclevesq@ibis.ulaval.ca

Conflict of Interest

The authors do not have commercial or other associations that may pose a conflict of interest.

Funding

This work was supported by a Cystic Fibrosis Canada postdoctoral fellowship to JJ; an Early Career Fellowship from the Leverhulme Trust to JLF and by Cystic Fibrosis Canada and the Canadian Institute for Health Research grants (Funding Reference Number: 86644) to RCL.

Meetings previously presented:

Part of this work was presented at the 13th International Conference on Pseudomonas in Australia (2011). Essential genes from the epidemic *Pseudomonas aeruginosa* LESB58 accessory genome involved in chronic lung infection. A very small part of this work was also presented as part of a poster at the European Cystic Fibrosis Society Conference (2011). Assessing the role of lysogenic bacteriophages in a cystic fibrosis epidemic strain of *Pseudomonas aeruginosa*.

Abstract

The opportunistic pathogen *Pseudomonas aeruginosa* causes chronic lung infection in cystic fibrosis patients. The Liverpool Epidemic Strain LESB58 is highly resistant to antibiotics, transmissible and associated with increased morbidity and mortality. Its genome contains 6 prophages and 5 genomic islands. We constructed a PCR-based signature-tagged mutagenesis library of 9,216 LESB58 mutants and screened in a rat model of chronic lung infection. A total of 162 mutants were identified as defective for *in vivo* maintenance, with 11 STM mutants having insertions in prophage and genomic island genes. Many of these mutants showed both diminished virulence and reduced phage production. Transcription profiling by qPCR and RNA-Seq suggests that disruption of these prophages has a widespread trans-acting effect on the transcriptome. This study demonstrates that temperate phages play a pivotal role in the establishment of infection through modulation of bacterial host gene expression.

Introduction

Pseudomonas aeruginosa is an opportunistic pathogen responsible for lung disease in immunocompromised and cystic fibrosis (CF) patients [1]. The widespread assumption that CF patients acquire only unique strains of *P. aeruginosa* from the environment was challenged when molecular typing was used to demonstrate the spread of a beta-lactam-resistant isolate, now known as the Liverpool Epidemic Strain (LES). The LES was first identified in a United Kingdom children's CF unit in 1996 [2] but has since been identified in North America [3-5]. Some LES isolates, including fully sequenced isolate LESB58 [6], exhibit an unusual phenotype characterized by early overexpression of the cell-density dependent quorum sensing (QS) regulon, including virulence-related secreted factors such as LasA, elastase and pyocyanin [7-9]. The LES is associated with greater patient morbidity and mortality compared to other *P. aeruginosa* strains [10] and was reported in unexpected cases of transmission from CF children to their parents [11, 12].

Whole genome sequencing of LESB58 revealed 90% of highly conserved core genome material and a unique accessory genome of 455 genes located within prophages (PPs) and genomic islands (GIs). Four of the six PPs are absent from the genome of strain PAO1 and only two of the five GIs identified in the LES showed similarity to any previously identified *P. aeruginosa* GI [6]. A previous study on LESB58 phage production indicated that five of the six PPs are able to produce active phage progeny [6]. These phages can be produced spontaneously or following a stress response such as induction with antibiotics [13]. The role of PPs in virulence as well as for in vivo initiation and maintenance of infection remains poorly understood [6].

In this report we build upon these studies to investigate the importance of specific genes implicated in in vivo maintenance, especially those found in the accessory genome of

LESB58. We performed PCR-based signature-tagged mutagenesis (STM), a negative selection technique that allows the identification of genes assumed to be essential *in vivo*. Preliminary results for LESB58 STM and identification of 48 mutants have been published previously [6]. Here, we focus on the functional impact of these accessory genome mutations with the goal of achieving a better understanding of the role played by mobile genetic elements in the maintenance of chronic lung infection among CF patients. Wild type strain LESB58 was compared with mutant strains for phenotypic characteristics, phage production and transcriptome profiling, demonstrating a clear role for temperate phages in the infection process and modulation of bacterial host gene expression.

Results and Discussion

Identification of LESB58 mutants defective for *in vivo* maintenance

A library of 9,216 LESB58 Tn5 insertion mutants was constructed and screened in a rat model of chronic lung infection [14, 15] and 162 mutants (affecting 135 genes) were identified as defective for *in vivo* maintenance. Sequencing of flanking genomic DNA was used to confirm the insertion site and orientation of the transposon insertion [16]. The 162 mutants along with their annotation are listed in Supplementary Table 1. The 135 genes affected by these mutations were classified into PseudoCAP functional categories (pseudomonas.com) [17].

Among LESB58 STM mutants defective for *in vivo* maintenance, 12 were found to have an insertion in a total of 11 GI or PP gene. Table 1 presents these genes, their predicted function and their respective accessory genome element, representing a total of 5 PPs and 2 GIs. It is well known that GIs and PPs can encode accessory genetic material in various human pathogens [6, 18, 19]. This additional genomic DNA may have a major role

in spreading genes within and/or among bacterial populations. In the CF lung, *P. aeruginosa* is exposed to an adverse, heterogeneous environment as well as various therapeutic regimes and polymicrobial communities [20].

The biofilm life cycle and virulence of *P. aeruginosa* strain PAO1 has been shown to depend upon filamentous phage Pf4 [21]. LES PPs 2 and 3 (LES ϕ 2, LES ϕ 3) have been shown to produce active phage particles in CF sputum [13, 22]. LES phages confer a competitive advantage in a rat model of chronic lung infection and may, therefore underpin LES prevalence and success [6].

In vivo competitive index analysis of genomic island and prophage mutants

To assess the degree of virulence attenuation for 11 GI and PP STM mutants, we performed an in vivo competitive index (CI) analysis in the rat model of chronic lung infection. After 7 days post infection, lungs were recovered and bacterial enumerations performed to determine the proportion of mutant to wild type bacterial cell colony forming units (CFUs). The CI for each mutant was calculated and results are represented in Figure 1. CI values of these STM mutants varied from 0.33 to 0.014, indicating an attenuation of virulence of 3- to 71-fold compared to the wild type. In vitro growth curves of each mutant were determined and showed no significant difference compared to wild type LESB58 (data not shown).

Population fitness studies have shown that temperate phages can regulate host genes and increase fitness [23]. The presence of a prophage, can provide additional fitness determinants such as protection against invasion by other bacteriophages, increased serum resistance, toxins and adhesion factors as well as traits that allow the lysogen to

successfully colonize a host [23]. Polylysogeny is frequently considered to be the result of an adaptive evolutionary process in which prophages confer fitness and/or virulence factors, thus making them important for evolution of both bacterial populations and infectious diseases.

Phage production and characterization of *P. aeruginosa* strains STM/PALES_08021 and STM/PALES_13521

We measured both spontaneous and induced phage production from PP and GI STM mutants (Figure 2). As shown in Figure 2A, insertions into 3 genes (PALES_08021, PALES_13451 and PALES_13521) resulted in significantly reduced production of spontaneous phage particles for LES ϕ 2 and LES ϕ 3 in comparison to wild type LESB58. Phage induction using Norfloxacin gave similar results (Figure 2B).

Representative mutants for each of these two prophages, *P. aeruginosa* STM/PALES_08021 and STM/PALES_13521, were therefore selected for further characterization. These mutants had low to intermediate CI values, representing a 3.7 and 14-fold reduction in in vivo virulence compared to the wild type strain (Figure 1), and severely impaired free phage production (Figure 2). In PP2, PALES_08021 encodes a protein homologous to DnaC with a predicted function in DNA replication (Table 1) and is located in the middle of an operon (Figure 3). The STM/PALES_13521 mutated gene encodes a putative phage portal protein (Table 1, Figure 3). STM/PALES_08021 and STM/PALES_13521 were characterized further for well-known *P. aeruginosa* LESB58 virulence factors including biofilm formation [24], motility [25], heat shock, hydrogen peroxidase, haemolysin [26], protease production [27], pyocyanin [28] and pyoverdine [29]; no differences were observed between mutants and wild type strains. As no variation was observed for typical virulence factors, we performed gene expression profiling for both

mutants in comparison with the wild type strain in order to explain their strong defect for in vivo maintenance and free phage production.

Transcriptome profiling of the free phage defective mutant *P. aeruginosa*

STM/PALES_08021

As insertion of a transposon may result in polar effects on flanking genes, we designed qPCR assays for each gene of the mutated operons encoding PALES_08021 and PALES_13521 (Supplementary Table 2). As shown in Figure 4, no polar effect was observed on upstream or downstream genes, and there was no significant deviation from wild type gene expression levels overall. This suggests that these mutations, through alteration of the protein sequence, have trans-acting effects on the transcriptome. Hence, we selected the most defective mutant for in vivo maintenance and free phage production, STM/PALES_08021, for transcriptome analysis [6, 13]. Sequencing of the PALES_08021 gene in STM/PALES_08021 was performed and showed that the transposon was effectively inserted toward the end of the gene, at nucleotide position 571 (of 788 nucleotides); the 3.37 kb Tn5tet-gfp transposon insertion does not encode a termination codon. While qPCR demonstrated that this mutation does not affect transcription, it is likely to have an impact on translation and/or protein function.

RNA-Seq data analysis led to the identification of 135 genes with significant differential expression between the mutant strain and wild type LESB58 (Supplementary Table 3), most of which (134) were up-regulated in the mutant. In line with qPCR results, none of the genes encoded in the operon of PALES_08021 showed differential expression according to RNA-Seq, which validates the transcriptome analysis. Among differentially expressed genes, the most significantly enriched functions compared to LESB58 genome composition were translation, post-translational modification & degradation; transcription,

RNA processing & degradation; and chaperones & heat shock proteins (Figure 5, Supplementary Table 3). There were also more differentially expressed genes than expected with functions related to cell division, energy metabolism, secreted factors (e.g. toxins, enzymes, alginate), chaperones and ATPases. These results suggest a trans-acting effect of the mutation in PALES_08021 on the transcriptome and show that a single mutation in PP2 has the potential to alter central cell functions such as transcription, translation and degradation. Among genes up-regulated in STM/PALES_08021, we also identified key functions relevant to CF chronic infections, namely antimicrobial susceptibility, quorum sensing, and mucoidy (Supplementary Table 3), which will require further investigation.

Conclusion

Through screening a library of *P. aeruginosa* LESB58 STM mutants, we have accumulated convincing evidence that PPs and GIs (particularly PP2 and PP3) are important for virulence and essential for maintenance in a chronic infection model. In particular, insertional mutations into genes of PP2 and PP3 have shown a major impact on the production of free phage particles and in vivo maintenance. These findings indicate that phages play a role in modulating key bacterial processes. Results presented here may reflect a diminished burden on bacterial transcription and translation mechanisms when phage production is switched off, which would echo the effect of other viruses on their host cell machinery [18].

This study clearly shows that prophages are not merely sitting in the genome. We observed a striking change in the expression of genes implicated in central processes such as transcription, translation and degradation due to a single mutation in PP2. Mutant strain STM/PLES_08021 also exerts increased expression of previously reported virulence-related genes [30]. In the wider context of chronic lung infections, this supports the notion

that reduced expression of classical virulence factors may be advantageous for persistence, and is consistent with the widespread observation that many isolates from CF infections carry mutations in reported virulence genes [31]. It is possible that reduced expression in prophage-carrying isolates is advantageous through both a diminished burden on transcription and translation mechanisms and reduced recognition by the host immune system.

This work provides novel insights into the effect of prophage genes and phage particle production on the regulation of global gene expression in *P. aeruginosa*. Since free phages are detectable in CF patient sputum [6] and can be induced using clinically relevant antibiotics [13] an understanding of their role in persistent infections is vital and may influence future therapeutic interventions.

Materials and methods

Ethics statement

The use of animals for this study was reviewed by the University Laval Committee for Animal Care (ULCAC; protocol number is 2011194).

Bacterial strains, plasmids, media and culture conditions

P. aeruginosa LESB58 [6] and *Escherichia coli* were grown in TSB (Tryptic Soy Broth, Difco) unless otherwise indicated. When needed, these media were supplemented with 1.5% Bacto-agar (Difco), ampicillin (Amp; 100 µg/ml for *E. coli* DH10B), Tetracycline (Tc; 10 µg/ml for *E. coli* DH10B or 45 µg/ml for *P. aeruginosa* LESB58 STM mutants; Sigma-Aldrich). Cloning of chromosomal DNA was performed using the pTZ18R vector (GE Healthcare). Restriction enzymes, T4 DNA ligase and T4 DNA polymerase were purchased from New England Biolabs.

PCR-based signature-tagged mutagenesis of LESB58

PCR-based signature-tagged mutagenesis (PCR-STM) is a well-defined method that has been used with *P. aeruginosa* PAO1 and adapted to strain LESB58 [32]. The rat model of chronic lung infection was used to screen 9216 mutants in vivo [33]. Disrupted genes were identified by Sanger sequencing as previously described [33] and confirmed by similarity searches with the *P. aeruginosa* LESB58 genome database at www.pseudomonas.com.

In vitro and in vivo competitive index

Agar beads were prepared according to a modified version of a previously described method [8]. From overnight cultures of each LESB58 STM mutant and the wild-type strain, a fresh culture was grown until an $OD_{600} = 1$ was reached. Subsequent steps were as described previously [8]. An input ratio of 1(LESB58):1(STM mutant) was used. Six animals were originally used for each strain. Due to unsuccessful infection or mortality, the experiment was performed a second time for some of the strains. In vitro and in vivo CIs were performed according to modified versions of previously described methods [8]. Each in vivo and in vitro competition was tested for statistical significance using the Mann-Whitney test from the GraphPrism Pro 5.0 software.

Phenotypic analysis of mutant strains

P. aeruginosa STM/PALES_08021 and STM/PALES_13521 strains were tested for biofilm formation, swimming, swarming and twitching motility, heat shock, hydrogen peroxidase, haemolysin, pyocyanin, pyoverdine and protease assays as described previously [4, 6, 29], and using the LESB58 strain as a control.

Spontaneous and induced phage production

For spontaneous phage production, cultures were grown to an OD of 0.5 ($A_{600\text{nm}}$). Phage levels were determined by incubation of cultures for 1 h (no antibiotic) followed by 1 h recovery in fresh medium. Induced active phage particles were enumerated using plaque assays, in which 100 μl of culture supernatant was added to 100 μl of 0.5 ($A_{600\text{nm}}$) *P. aeruginosa* PAO1 (the indicator strain) in 5 ml molten 0.4 % (w/v) Luria agar and poured onto L-agar, in triplicate. It was previously demonstrated that plaques visible in this assay are produced by prophages 2 and 3 [13]. Phage induction using Norfloxacin was performed by adding the antibiotic at the MIC (Norfloxacin, 50 $\mu\text{g/ml}$).

RNA extraction, cDNA synthesis and qPCR

Total RNA was extracted from bacterial cultures at mid-log phase having an optical density of 0.6-0.8 at 650 nm using the RNeasy Midi Kit (Invitrogen) according to the instructions of the supplier. cDNA was synthesized using 1 μg of total RNA as the template (Quantitect Reverse Transcription Kit, QIAGEN and random primers, Invitrogen) according to the manufacturer's protocol. Quantitative PCR was performed on the Roche Light Cycler 480. Primers used are shown in Supplementary Table 2. Differential gene expression between the wild-type and STM mutants was assessed using the Mann-Whitney test on GraphPad Prism 5.0.

Transcriptome profiling

Total RNA was depleted of rRNA and tRNA using the RiboMinus Kit (Invitrogen). Total RNA and mRNA quality were assessed using the Agilent RNA 6000 Pico Kit and the BioAnalyzer 2100 (Agilent Technologies). cDNA synthesis was performed using the cDNA synthesis system from Roche according to the instructions of the supplier. cDNA samples were sent to the genomic platform at the Institut de biologie integrative et des

systems (IBIS, Université Laval, Québec, Canada) for transcriptome sequencing using the Roche 454 pyrosequencing method on the Genome Sequencer FLX system with Titanium chemistry. Data obtained from whole transcriptome sequencing was assembled and analysed with Newbler (Roche). Reads were mapped on the *P. aeruginosa* LESB58 reference genome available on the Pseudomonas genome database (www.pseudomonas.com). Differential gene expression was assessed using the R BioConductor package EdgeR [34]. Statistical analysis was based on the negative binomial distribution that takes into account the presence of over-dispersion across the samples. Three wild type RNA-seq libraries were compared to one mutant library. Raw counts were directly used in the R package and normalization of the number of reads between samples was done with the quantile-adjusted method. Separate dispersions were estimated for individual tags (tagwise dispersion approach). Adjusted p-values according to the method of Benjamini and Hochberg [35] were used to select differentially expressed genes (adjusted $p < 0.01$).

Acknowledgments

We thank people at the IBIS Plateforme d'analyses génomiques for next-generation sequencing and the IBIS bioinformatics group for transcriptome analysis.

References

1. Stover CK, Pham XQ, Erwin AL, et al. Complete genome sequence of *Pseudomonas aeruginosa* PA01, an opportunistic pathogen. *Nature* **2000**; 406:959-64.
2. Cheng K, Smyth RL, Govan JR, et al. Spread of beta-lactam-resistant *Pseudomonas aeruginosa* in a cystic fibrosis clinic. *Lancet* **1996**; 348:639-42.
3. Aaron SD, Vandemheen KL, Ramotar K, et al. Infection with transmissible strains of *Pseudomonas aeruginosa* and clinical outcomes in adults with cystic fibrosis. *JAMA* **2010**; 304:2145-53.
4. Jeukens J, Boyle B, Kukavica-Ibrulj I, et al. Comparative genomics of isolates of a *Pseudomonas aeruginosa* epidemic strain associated with chronic lung infections of cystic fibrosis patients. *PLoS ONE* **2014**; 9:e87611.
5. Dettman JR, Rodrigue N, Aaron SD, Kassen R. Evolutionary genomics of epidemic and nonepidemic strains of *Pseudomonas aeruginosa*. *PNAS* **2013**; 110:21065-70.
6. Winstanley C, Langille MG, Fothergill JL, et al. Newly introduced genomic prophage islands are critical determinants of in vivo competitiveness in the Liverpool Epidemic Strain of *Pseudomonas aeruginosa*. *Genome Res* **2009**; 19:12-23.
7. Fothergill JL, Panagea S, Hart CA, Walshaw MJ, Pitt TL, Winstanley C. Widespread pyocyanin over-production among isolates of a cystic fibrosis epidemic strain. *BMC Microbiol* **2007**; 7:45.
8. Kukavica-Ibrulj I, Bragonzi A, Paroni M, et al. In vivo growth of *Pseudomonas aeruginosa* strains PAO1 and PA14 and the hypervirulent strain LESB58 in a rat model of chronic lung infection. *J Bacteriol* **2008**; 190:2804-13.

9. Salunkhe P, Smart CH, Morgan JA, et al. A cystic fibrosis epidemic strain of *Pseudomonas aeruginosa* displays enhanced virulence and antimicrobial resistance. *J Bacteriol* **2005**; 187:4908-20.
10. Al-Aloul M, Crawley J, Winstanley C, Hart CA, Ledson MJ, Walshaw MJ. Increased morbidity associated with chronic infection by an epidemic *Pseudomonas aeruginosa* strain in CF patients. *Thorax* **2004**; 59:334-6.
11. Ashish A, Shaw M, Winstanley C, Ledson MJ, Walshaw MJ. Increasing resistance of the Liverpool Epidemic Strain (LES) of *Pseudomonas aeruginosa* (Psa) to antibiotics in cystic fibrosis (CF)--a cause for concern? *J Cyst Fibros* **2012**; 11:173-9.
12. McCallum SJ, Gallagher MJ, Corkill JE, Hart CA, Ledson MJ, Walshaw MJ. Spread of an epidemic *Pseudomonas aeruginosa* strain from a patient with cystic fibrosis (CF) to non-CF relatives. *Thorax* **2002**; 57:559-60.
13. Fothergill JL, Mowat E, Walshaw MJ, Ledson MJ, James CE, Winstanley C. Effect of antibiotic treatment on bacteriophage production by a cystic fibrosis epidemic strain of *Pseudomonas aeruginosa*. *Antimicrob Agents Chemother* **2011**; 55:426-8.
14. Cash HA, Woods DE, McCullough B, Johanson WG, Jr., Bass JA. A rat model of chronic respiratory infection with *Pseudomonas aeruginosa*. *Am Rev Respir Dis* **1979**; 119:453-9.
15. Lehoux DE, Sanschagrín F, Levesque RC. Genomics of the 35-kb pvd locus and analysis of novel pvdIJK genes implicated in pyoverdine biosynthesis in *Pseudomonas aeruginosa*. *FEMS Microbiol Lett* **2000**; 190:141-6.
16. Lehoux DE, Sanschagrín F, Kukavica-Ibrulj I, Potvin E, Levesque RC. Identification of novel pathogenicity genes by PCR signature-tagged mutagenesis and related technologies. *Methods Mol Biol* **2004**; 266:289-304.

17. Winsor GL, Lam DK, Fleming L, et al. Pseudomonas Genome Database: improved comparative analysis and population genomics capability for Pseudomonas genomes. *Nucleic Acids Res* **2011**; 39:D596-600.
18. Brussow H, Canchaya C, Hardt WD. Phages and the evolution of bacterial pathogens: from genomic rearrangements to lysogenic conversion. *Microbiol Mol Biol Rev* **2004**; 68:560-602.
19. Tormo-Mas MA, Mir I, Shrestha A, et al. Moonlighting bacteriophage proteins derepress staphylococcal pathogenicity islands. *Nature* **2010**; 465:779-82.
20. Brockhurst MA, Colegrave N, Rozen DE. Next-generation sequencing as a tool to study microbial evolution. *Mol Ecol* **2011**; 20:972-80.
21. Rice SA, Tan CH, Mikkelsen PJ, et al. The biofilm life cycle and virulence of *Pseudomonas aeruginosa* are dependent on a filamentous prophage. *ISME J* **2009**; 3:271-82.
22. James CE, Fothergill JL, Kalwij H, et al. Differential infection properties of three inducible prophages from an epidemic strain of *Pseudomonas aeruginosa*. *BMC Microbiol* **2012**; 12:216.
23. Chen Y, Golding I, Sawai S, Guo L, Cox EC. Population fitness and the regulation of *Escherichia coli* genes by bacterial viruses. *PLoS Biol* **2005**; 3:e229.
24. O'Toole GA, Kolter R. Flagellar and twitching motility are necessary for *Pseudomonas aeruginosa* biofilm development. *Mol Microbiol* **1998**; 30:295-304.
25. Rashid MH, Rumbaugh K, Passador L, et al. Polyphosphate kinase is essential for biofilm development, quorum sensing, and virulence of *Pseudomonas aeruginosa*. *PNAS* **2000**; 97:9636-41.

26. Frees D, Qazi SN, Hill PJ, Ingmer H. Alternative roles of ClpX and ClpP in *Staphylococcus aureus* stress tolerance and virulence. *Mol Microbiol* **2003**; 48:1565-78.
27. Laux DC, Corson JM, Givskov M, et al. Lysophosphatidic acid inhibition of the accumulation of *Pseudomonas aeruginosa* PAO1 alginate, pyoverdinin, elastase and LasA. *Microbiology* **2002**; 148:1709-23.
28. Schaber JA, Carty NL, McDonald NA, et al. Analysis of quorum sensing-deficient clinical isolates of *Pseudomonas aeruginosa*. *J Med Microbiol* **2004**; 53:841-53.
29. Potvin E, Lehoux DE, Kukavica-Ibrulj I, et al. In vivo functional genomics of *Pseudomonas aeruginosa* for high-throughput screening of new virulence factors and antibacterial targets. *Environ Microbiol* **2003**; 5:1294-308.
30. Smith EE, Buckley DG, Wu Z, et al. Genetic adaptation by *Pseudomonas aeruginosa* to the airways of cystic fibrosis patients. *Proceedings of the National Academy of Sciences* **2006**; 103:8487-92.
31. Folkesson A, Jelsbak L, Yang L, et al. Adaptation of *Pseudomonas aeruginosa* to the cystic fibrosis airway: an evolutionary perspective. *Nat Rev Microbiol* **2012**; 10:841-51.
32. Lehoux DE, Sanschagrín F, Levesque RC. Discovering essential and infection-related genes. *Curr Opin Microbiol* **2001**; 4:515-9.
33. Sanschagrín F, Kukavica-Ibrulj I, Levesque RC. Essential genes in the infection model of *Pseudomonas aeruginosa* PCR-based signature-tagged mutagenesis. *Methods Mol Biol* **2008**; 416:61-82.
34. Robinson MD, McCarthy DJ, Smyth GK. edgeR: a Bioconductor package for differential expression analysis of digital gene expression data. *Bioinformatics* **2010**; 26:139-40.

35. Klipper-Aurbach Y, Wasserman M, Braunspiegel-Weintrob N, et al. Mathematical formulae for the prediction of the residual beta cell function during the first two years of disease in children and adolescents with insulin-dependent diabetes mellitus. *Med Hypotheses* **1995**; 45:486-90.

Accepted Manuscript

Figure Legends

Figure 1. In vivo competitive index of mutant *P. aeruginosa* LESB58 strains with an insertion in a prophage or genomic island. Mutants were grown in the rat lung in competition with wild-type (WT) strain LESB58 for 7 days. Each circle represents the survival ratio, or competitive index (CI), of the mutant/WT for a single animal. The geometric mean of the CI replicates for a mutant is shown as a solid line and corresponds to the CI value indicated on the x axis. All CIs were significantly smaller than 1 (Mann-Whitney test, p-value < 0.05).

Figure 2. Phage production of strain *P. aeruginosa* LESB58 and mutant strains.

Spontaneous (A) and norfloxacin induced (B) phage production was measured to compare wild type strain LESB58 and 12 mutants defective for in vivo maintenance with insertions in 5 prophages and 2 genomic islands. Phage production in this assay corresponds to LES ϕ 2 and LES ϕ 3. Error bars represent standard deviation for 9 replicates. Dotted frames indicate the two mutants characterized in this study. A Kruskal-Wallis ANOVA was performed by comparing phage production for each mutant to LESB58 (* p < 0.05; ** p < 0.001)).

Figure 3. Signature-tagged mutagenesis insertions in LESB58 prophages 2 and 3. A.

STM/PALES_08021, LES prophage 2. B. STM/PALES_13521, LES prophage 3. Grey arrows were annotated coding sequences (pseudomonas.com), black arrows represent genes of the mutated operon and dotted arrows indicate the location of the mutational insertion.

Figure 4. qPCR of selected genes in mutant strains *P. aeruginosa* STM/PALES-08021 and STM/PALES_13521. qPCR of the gene harbouring the mutational insertion and flanking genes was performed for both mutants compared to wild type strain *P. aeruginosa* LESB58. Housekeeping gene *rspL* was used as a reference gene. A. Expression levels for genes in operon PALES_08011. B. Expression levels for genes in the operon PALES_13511. No measurement in mutant strains was significantly different from the wild type.

Figure 5. PseudoCAP annotation of differentially expressed genes between mutant STM/PALES_08021 and wild type strain *P. aeruginosa* LESB58. Transcriptome sequencing (RNA-Seq) was performed for the PALES_08021 mutant and wild-type LESB58. Significant differential gene expression (adjusted $p < 0.01$) was assessed with EdgeR. Fisher's exact test was used to compare the functional distribution of differentially expressed genes with that of the whole genome. Qvalue was used for multiple testing correction (* $q < 0.05$, ** $q < 0.01$).

Tables

Table1. Annotation of mutant genes located within a prophage or genomic island

Mutant gene^a	Strain	Mutated gene function	Accessory genome element^b	PseudoCAP class^c
PALES_06181	PA01 ortholog PA0622	Probable bacteriophage protein	LES prophage 1	Related to phage, transposon, or plasmid
PALES_08021	na	DNA replication protein DnaC	LES prophage 2	Hypothetical, unclassified, unknown
PALES_13261	na	Hypothetical protein	LES prophage 3	Hypothetical, unclassified, unknown
PALES_13451	na	Putative uncharacterized protein PflO1_0304	LES prophage 3	Hypothetical, unclassified, unknown
PALES_13521	na	Putative portal protein, phage portal 2	LES prophage 3	Related to phage, transposon, or plasmid

PALES_13541	na	Putative RecA/RadA recombinase	LES prophage 3	Hypothetical, unclassified, unknown
PALES_25621	na	Putative lytic enzyme	LES prophage 5	Membrane
PALES_30891	na	Hypothetical protein	LES GI-4	Hypothetical, unclassified, unknown
PALES_31041	na	Propionate catabolism operon regulator prpR	LES GI-4	Putative enzymes
PALES_41191	PA0727	Hypothetical protein from bacteriophage Pf1	LES prophage 6	Related to phage, transposon, or plasmid
PALES_45041	na	Hypothetical protein	LES GI-5	Hypothetical, unclassified, unknown

^a Identified among 162 signature-tagged mutant strains defective for in vivo maintenance in the rat model of chronic infection compared to wild-type strain *P. aeruginosa* LESB58

^bGI: genomic island

^c*Pseudomonas aeruginosa* Community Annotation Project functional classes

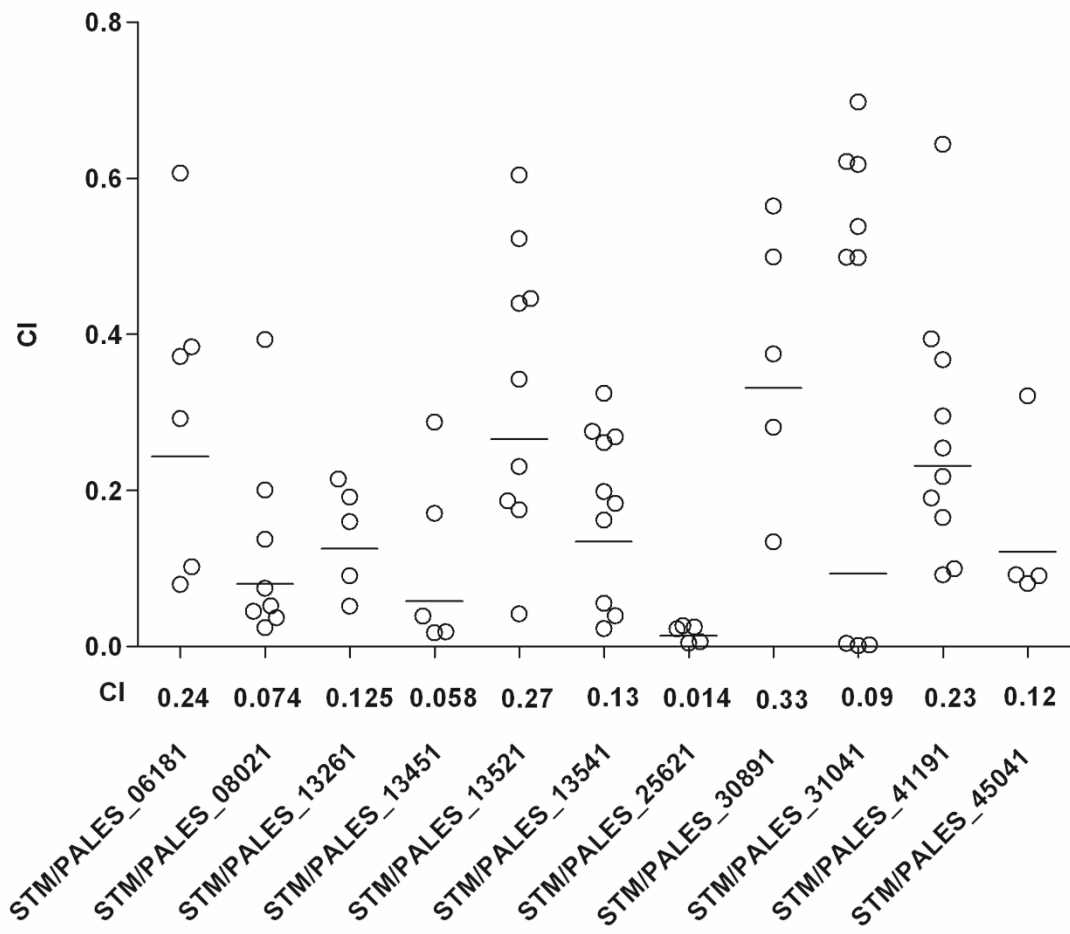

Acceptec

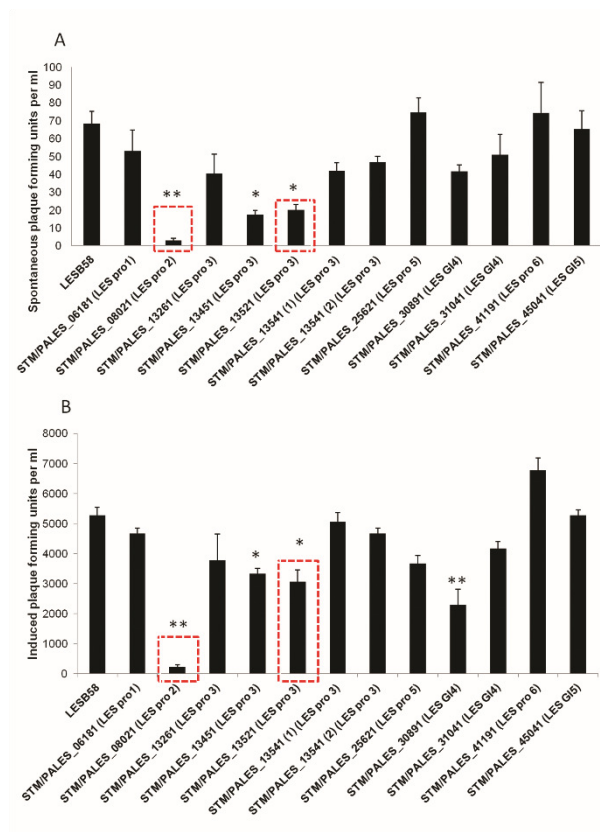

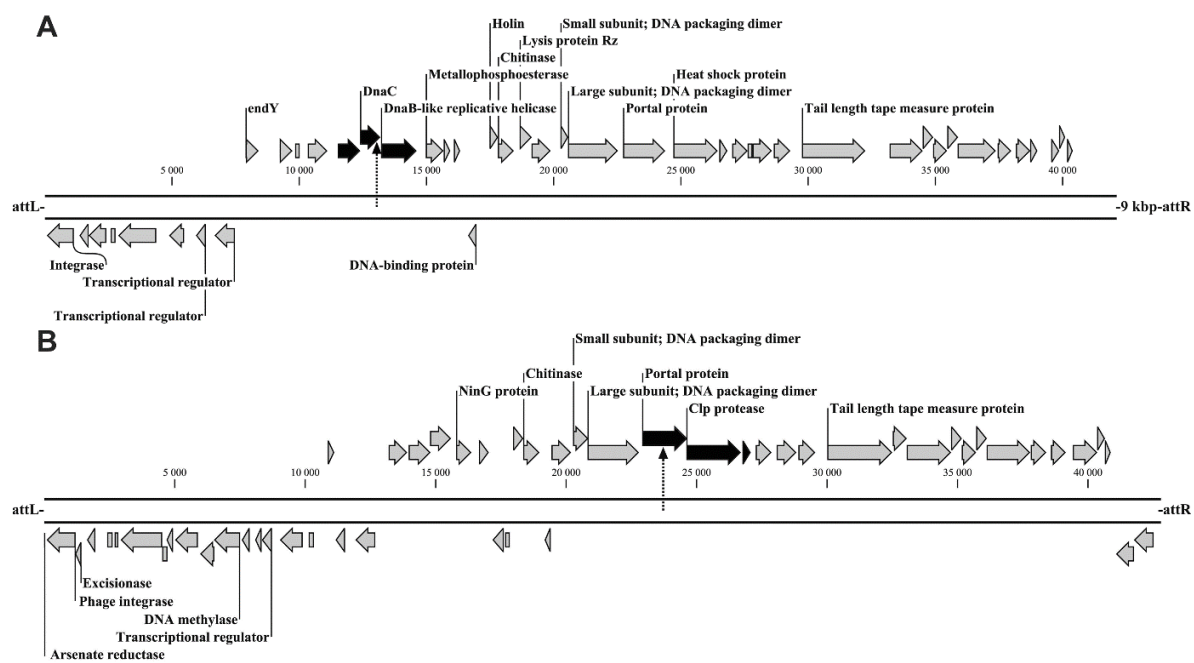

Accepted Manuscript

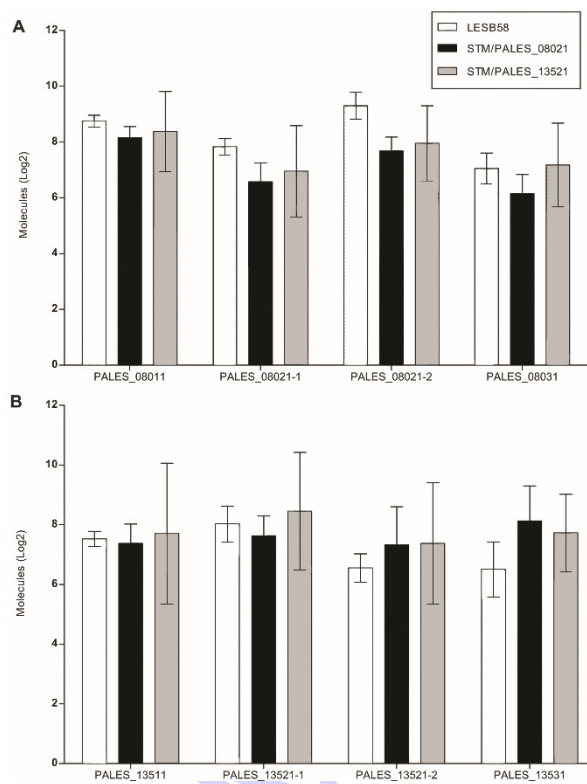

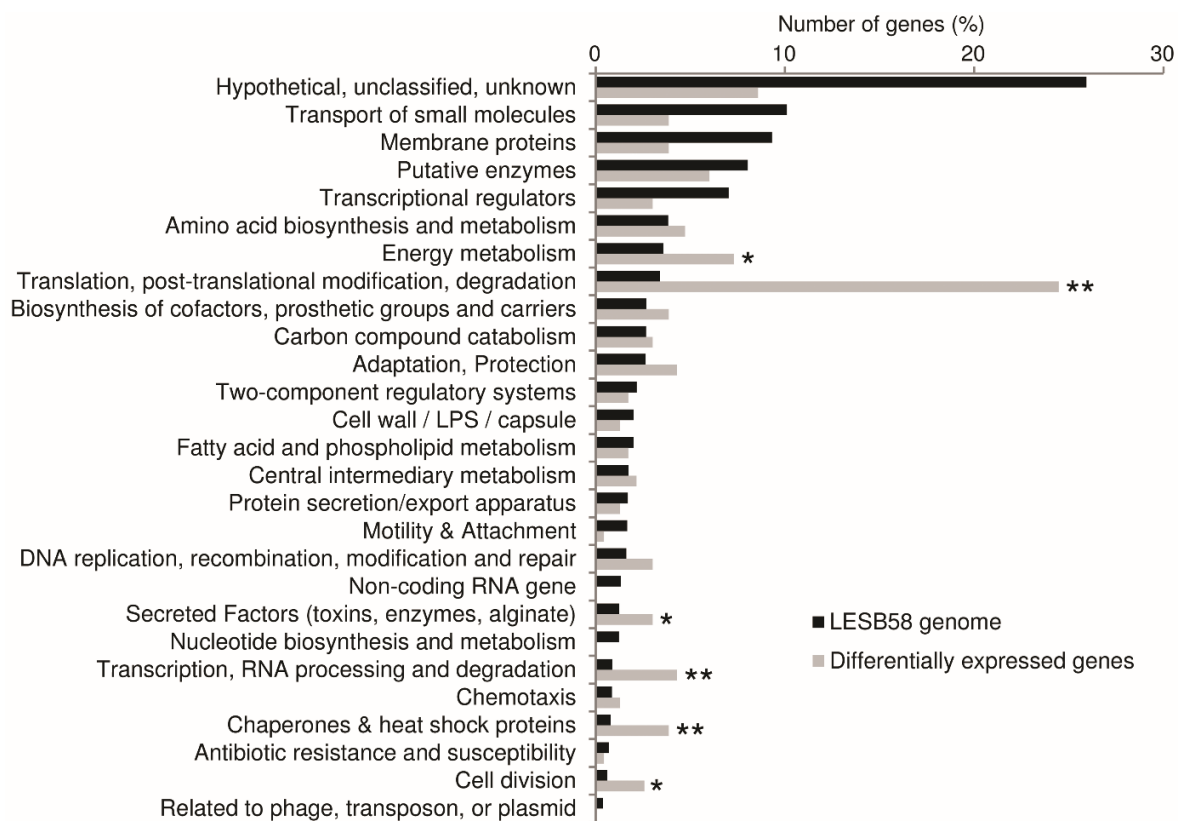

Accepted