



## Strathprints Institutional Repository

**Tzelepis, Dimitrios and Dysko, Adam and Booth, Campbell (2016)  
Performance of loss-of-mains detection in multi-generator power  
islands. In: The 13th IET International Conference on Developments in  
Power System Protection 2016, 2016-03-07 - 2016-03-10, The Sheraton  
Hotel. ,**

This version is available at <http://strathprints.strath.ac.uk/55387/>

**Strathprints** is designed to allow users to access the research output of the University of Strathclyde. Unless otherwise explicitly stated on the manuscript, Copyright © and Moral Rights for the papers on this site are retained by the individual authors and/or other copyright owners. Please check the manuscript for details of any other licences that may have been applied. You may not engage in further distribution of the material for any profitmaking activities or any commercial gain. You may freely distribute both the url (<http://strathprints.strath.ac.uk/>) and the content of this paper for research or private study, educational, or not-for-profit purposes without prior permission or charge.

Any correspondence concerning this service should be sent to Strathprints administrator: [strathprints@strath.ac.uk](mailto:strathprints@strath.ac.uk)

# Performance of Loss-Of-Mains Detection in Multi-Generator Power Islands

**Dimitrios Tzelepis**  
*EEE Department*  
*University of Strathclyde*  
*Glasgow, UK*  
*dimitrios.tzelepis@strath.ac.uk*

**Adam Dyśko**  
*EEE Department*  
*University of Strathclyde*  
*Glasgow, UK*  
*a.dysko@strath.ac.uk*

**Campbell Booth**  
*EEE Department*  
*University of Strathclyde*  
*Glasgow, UK*  
*campbell.d.booth@strath.ac.uk*

**Keywords**—Loss of Mains, Generation Mix, Distributed Generation, Multi-Generator Power Islands, ROCOF

## Abstract

This paper presents an investigation of the impact of multi-generator power islands on the performance of the most-commonly used anti-islanding protection method, Rate of Change of Frequency (ROCOF). In particular, various generating technology mixes including Photovoltaic panels (PV), Doubly Fed Induction Generators (DFIGs) and Synchronous Generators (SG) are considered. The Non-Detection Zone (NDZ) for a range of ROCOF setting options is assessed systematically and expressed as a percentage of generator MVA rating. It was discovered that ROCOF protection becomes very ineffective when protection time delay is applied. In the majority of islanding situations the generator is disconnected by frequency-based G59 protection.

## 1. Introduction

Distributed Generation (DG) is becoming increasingly more popular due to the drive to decarbonise power systems and use renewable energy sources. The location and economics of renewable and sustainable energy sources have shown that most of these generators should be connected at the distribution rather than transmission level. One of the key requirements for connecting distributed generation to utility networks is to provide Loss of Mains (LOM) protection (also termed as anti-islanding protection). During an LOM event a part of the grid (including DG) loses physical connection with the main part of the network (the mains). Operating in islanded mode can be dangerous for power equipment but also for human life which results from a number of potential hazards such as [1]:

- Out of phase reclosing
- Insufficient or missing grounding of the islanded part
- Production of potentially hazardous mechanical torques
- Unacceptable levels of voltage and/or Frequency
- Safety risks for utility personnel

Consequently, such condition should be detected and actions to disconnect DG should be initiated without unnecessary delay.

There are numerous techniques and approaches for detecting a LOM event. According to their principle of operation they can be broadly classified into the following three groups [2]:

- Passive methods
- Active methods
- Communication-based methods

The principle of operation of passive methods is that during an LOM event some of the system parameters such as frequency, voltage angle, active and reactive power will be disturbed. Hence by continuously monitoring these parameters an LOM condition can be detected. Some of the most popular are the ROCOF and Vector Shift (VS) [3], Rate of Change of Voltage Angle Difference (ROCPAD) [4], Rate of Change of Power (ROCOP) [5], Apparent Power-Based [6] and Peak-Ratio Analysis [7].

Concerning the active methods, they are continuously and directly interacting with the power network. This is achieved by injecting small signals into the network. By monitoring the response to these signals a decision can be made, whether an LOM occurred or not. Most of the time, active methods are used when inverter based DG is connected to a power network. Some of the frequently mentioned techniques include Active Frequency Drift (AFD) [8], Sandia Frequency Shift (SFS) [9], [10], and Reactive Power Disturbance (RPD) [11].

The third group includes the methods which make use of some form of communication between the grid and distributed generator. Grid operators already use a variety of communication media to control and monitor the state of their systems. Moreover, some DNOs actually favour communication-based direct intertripping as the most reliable LOM protection solution. Communication-based methods are very promising since their NDZs can be effectively reduced to zero, and at the same time they maintain full immunity to external system faults. However, they can be expensive when a dedicated communication channel is required. Examples of communication based methods include direct intertripping, methods based on satellite communications [12] and Phasor Measurement Units (PMU) incorporating internet communication [13].

## 2. Multi-Generator Power Islands

Modern distribution networks are increasingly populated by inverter-connected generation, leading to reduced overall system inertia, typically due to the decoupling of kinetic

energy (if any) from the grid through the use of a power electronics interface. This not only puts system stability at increased risk but also poses major concerns regarding the security of commonly used anti-islanding protection methods such as ROCOF and VS which may spuriously operate and cause unnecessary disconnection of large amounts of distributed generation in response to non-LOM events. For this reason there is pressure to increase the LOM protection settings making it less sensitive to system-wide events. Such change, however, calls for systematic assessment of the LOM protection performance in terms of sensitivity to genuine LOM events.

Although LOM protection performance studies have been undertaken in the past, most of the existing work considers only a single generator within the power island [14], [15]. This situation is depicted in Figure 1 as Case A. While historically such an approach was reasonable, rapidly increasing numbers of DG connections lead to high probability of islanding with more than one generator in the island. Therefore, this paper includes an investigation of various generation mixes (depicted in Figure 1 as Case B) to provide more representative test environment for assessing the performance of existing islanding detection methods. In particular, various mixes including PV, DFIG and SG are considered. The presented LOM studies are performed using an 11 kV network model, and a dynamic model of a commercially available ROCOF relay, commonly used in the UK. Simulation scenarios included in the paper aim to assess the impact of increasing ROCOF relay settings on the protection NDZ in order to achieve the best compromise between dependability and security.

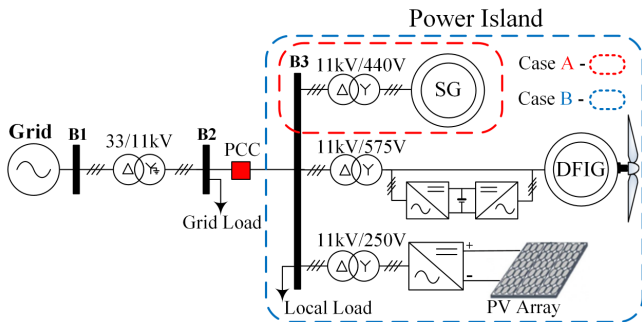

Figure 1: Distribution Network illustrating the Potential Power Islands

Available registers of UK-installed DG with capacities of less than 5MW have been utilised to ascertain the most dominant generation mixes in the UK. The majority of the UK DNOs were included in the analysis. An example DG register for Western Power Distribution (WPD) can be accessed online from [16]. The final outcome of this analysis is presented in Table 1, where six dominant generation groups are included. These groups subsequently formed 12 distinct generation mixes including single technology connections, as well as the mixes of two and three technologies in different installed capacity proportions as indicated in Table 2.

Each DG is connected to the grid through a step up transformer with unearthed HV winding (as shown in Figure 1) to represent the typical DG connection arrangement in the UK. For synchronous machine modelling, an active power and voltage (P-V) control scheme is employed, which includes fixed power governor and an IEEE type-1

DG Group	Generation Technology
1	SM
2	PV
3	DFIG
4	SM, PV
5	PV, DFIG
6	SM, PV, DFIG

Table 1: Islanding Groups

synchronous machine voltage regulator. PV panels are connected to the grid via a series of devices including a voltage boost converter, a three phase IGBT-based inverter, an RC filter and a power transformer. Maximum Power Point Tracking (MPPT) operation is integrated using the Perturb and Observe (P&O) algorithm [17] while voltage support is also utilised. The DFIG model consists of a wound-rotor induction generator, driven by a wind turbine and an AC/DC/AC IGBT-based PWM converter. The stator windings are connected to the distribution network through the step up transformer, while the rotor is fed at variable frequency through the AC/DC/AC converter. The power converter offers the capability for variable speed operation and decoupled control of active and reactive power.

Generation Mix	SG	PV	DFIG
1	100%	-	-
2	-	100%	-
3	-	-	100%
4	75%	25%	-
5	50%	50%	-
6	25%	75%	-
7	-	75%	25%
8	-	50%	50%
9	-	25%	75%
10	70%	15%	15%
11	15%	70%	15%
12	15%	15%	70%

Table 2: Generation Technologies Portion within a 2 MVA Total Generation Mix

### 3. NDZ Assessment

The objective of this experimental evaluation is to determine the non-detection zone (NDZ) of the ROCOF protection as a percentage of DG MVA rating. The imbalance of active and reactive power flowing through the point of common coupling (PCC) is adjusted independently to determine the NDZ. The NDZ is determined for both import and export of pre-island active and reactive power across the PCC. Four different ROCOF settings options as presented in Table 3 were considered. Setting options 1 and 2 represent historical ROCOF setting practice in UK, while options 3 and 4 are aimed at the future dynamic low inertia UK power system where rates of change of frequency up to 1 Hz/s are anticipated.

Setting Option	ROCOF [Hz/s]	Time Delay [s]
1	0.13	0
2	0.2	0
3	0.5	0.5
4	1.0	0.5

Table 3: ROCOF Setting Options

A validated dynamic model of a commercially available DG interface relay has been utilised in this test [18]. An automatic search routine developed specifically for this study was employed to iteratively change the power imbalance and monitor the relay response. Imbalance of one type of power (e.g. active) was gradually increased while the other category of power (e.g. reactive) is maintained at the balance point (balance between local load and DG output). This was achieved by adjusting the local demand and/or generator reactive power output. With each incremental change in power imbalance across the PCC, the numerical relay model was injected with the simulated 3-phase voltages (measured on bus B3 in Figure 1) and the relay response was recorded. The reported percentage values of NDZ (considering separately power import and export) for active and reactive power are expressed according to equations 1 to 4. The NDZ search in this study was limited to 50% of total installed capacity for both directions (import & export) across the PCC. In cases where  $NDZ > 50\%$  the LOM protection would be considered highly unreliable, and therefore, the exact value of NDZ was not seen as relevant.

$$NDZ_{P(I)} = \frac{P_{PCC(I)}}{S_{DG}} \quad (1)$$

$$NDZ_{P(E)} = \frac{P_{PCC(E)}}{S_{DG}} \quad (2)$$

$$NDZ_{Q(I)} = \frac{Q_{PCC(I)}}{S_{DG}} \quad (3)$$

$$NDZ_{Q(E)} = \frac{Q_{PCC(E)}}{S_{DG}} \quad (4)$$

Where  $NDZ_{P(I)}, NDZ_{P(E)}$  are the active power NDZ values assessed for import and export respectively,  $NDZ_{Q(I)}, NDZ_{Q(E)}$  are the corresponding reactive power NDZ values,  $P_{PCC(I)}, P_{PCC(E)}$  are the minimum active power amounts across the PCC resulting in successful LOM detection within the maximum assumed period of time (3 seconds was assumed in this study) defined separately for import and export, and  $Q_{PCC(I)}, Q_{PCC(E)}$  are the corresponding reactive power values across the PCC.  $S_{DG}$  is the DG rating in MVA.

During the NDZ assessment for ROCOF, the other G59 protection functions [19] (over-frequency, under-frequency, over-voltage, under-voltage) were also enabled. In cases where any of these functions provided narrower NDZ than that of the ROCOF protection (considering 3 seconds as a maximum operation time) the ROCOF NDZ was ignored.

#### 4. ROCOF Performance

The combined NDZ results (with both ROCOF and G59 protection enabled) are summarised for all 12 generation mixes in Table 4 and graphically depicted in Figure 4. Values denoted by (\*) and (#) indicate G59 frequency and voltage dependant protection respectively. In fact, such values imply that G59 protection has a narrower NDZ than the ROCOF protection (considering 3 seconds as a maximum operation time). The values presented as zero indicate that at the given setting option it was not possible to achieve stable islanding operation for a period of at least 3s without ROCOF protection operation.

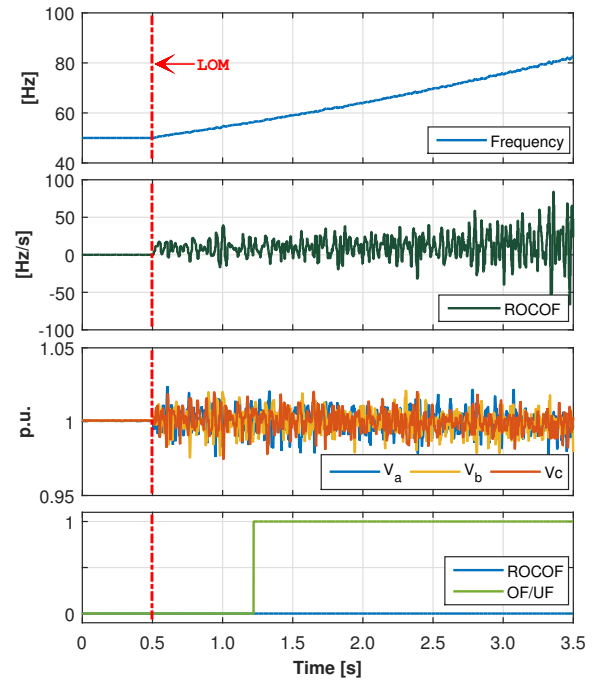

Figure 2: Frequency, ROCOF, Voltage and Relay response for Generation Mix 2 and 2% Reactive Power Import prior to LOM

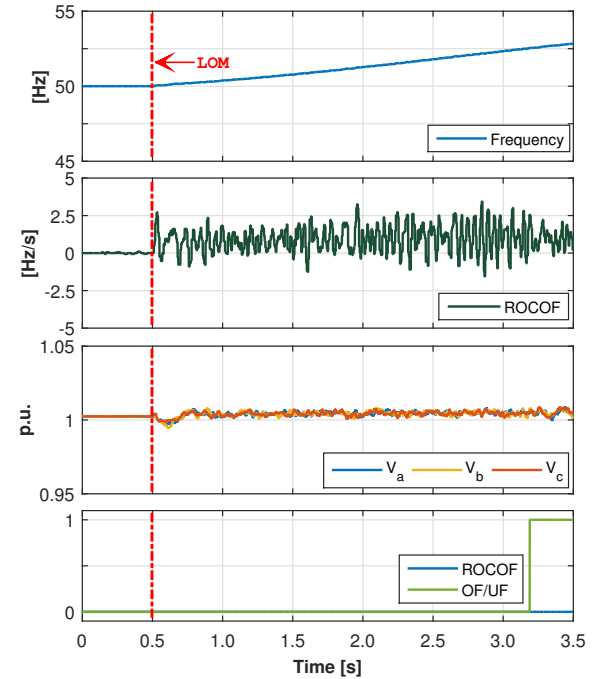

Figure 3: Frequency, ROCOF, Voltage and Relay response for Generation Mix 5 and 2% Active Power Export prior to LOM

By analysing Table 4 (a to l) it can be seen that for setting options 1 and 2, the NDZ is narrow in all cases ( $< 2.5\%$ ) which indicates very good sensitivity of the ROCOF relay. On the other hand, considering setting options 3 and 4, the NDZ is much wider, reaching values greater than 20% in some cases.

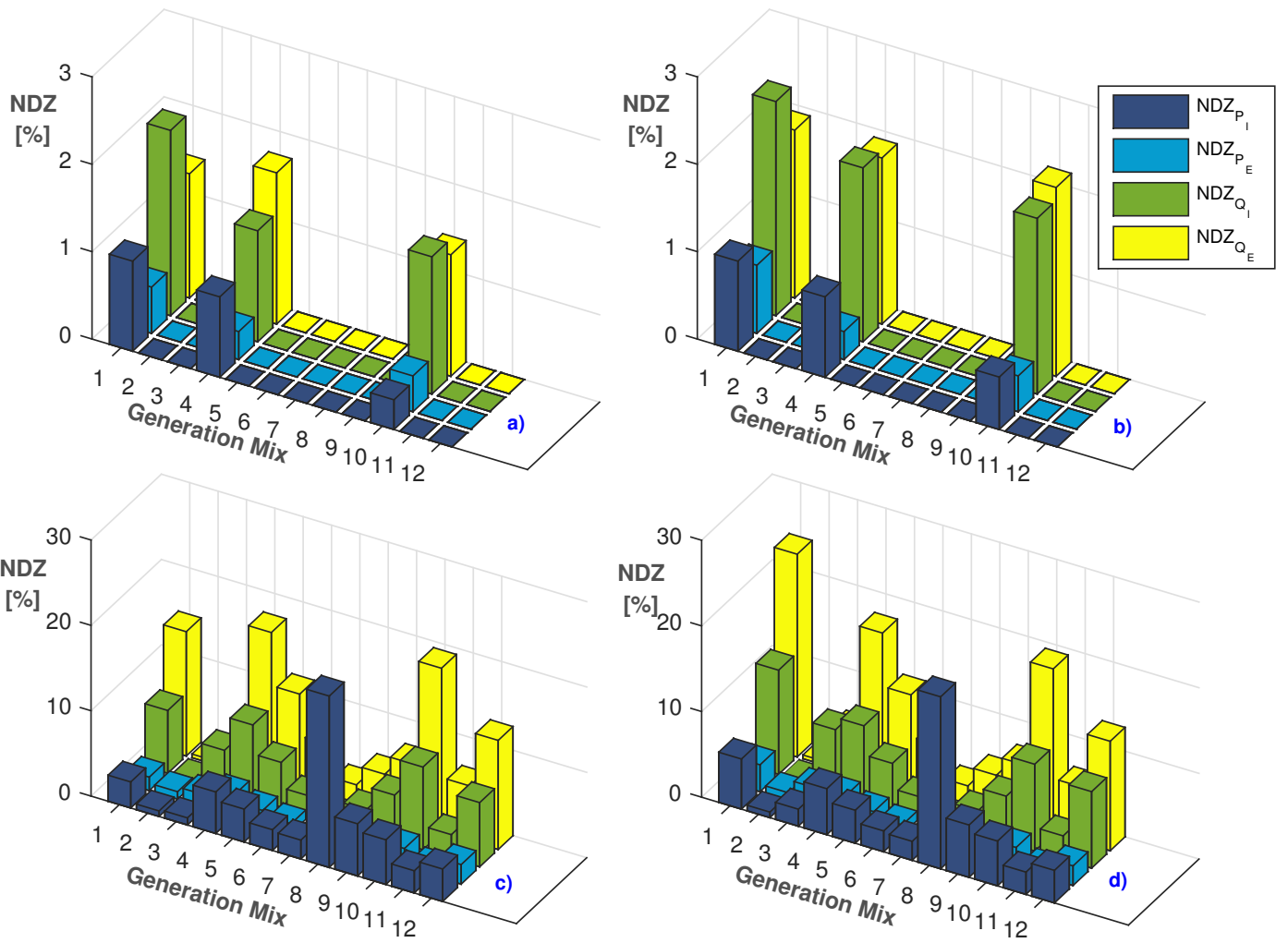

Figure 4: NDZ representation for a) Setting Option 1, b) Setting Option 2, c) Setting Option 3, d) Setting Option 4

Set. Option	$NDZ_{P_I}$	$NDZ_{P_E}$	$NDZ_{Q_I}$	$NDZ_{Q_E}$	$NDZ_{P_I}$	$NDZ_{P_E}$	$NDZ_{Q_I}$	$NDZ_{Q_E}$	$NDZ_{P_I}$	$NDZ_{P_E}$	$NDZ_{Q_I}$	$NDZ_{Q_E}$
<b>a) Generation Mix 1</b>												
1	1.03	0.53	2.12	1.42	0	0	0	0	0	0	0	0
2	1.03	0.78	2.45	1.92	0	0	0	0	0	0	0	0
3	3.05	1.58	7.36	14.56	0.65*	0.87*	0.28*	0.43*	0.83	1.44	4.68	2.29
4	5.85	3.14*	12.16*	23.67*	0.65*	0.87*	0.28*	0.43*	1.98	2.38	7.20	5.04
<b>b) Generation Mix 2</b>												
1	0.92	0.32	1.27	1.73	0	0	0	0	0	0	0	0
2	0.92	0.32	1.99	1.9	0	0	0	0	0	0	0	0
3	4.86	2.49*	8.65*	17.45*	3.85*	1.66*	5.26*	11.23*	2.43*	1.10*	2.31*	6.33*
4	5.37*	2.49*	8.65*	17.45*	3.85*	1.66*	5.26*	11.23*	2.43*	1.10*	2.31*	6.33*
<b>c) Generation Mix 3</b>												
1	0	0	0	0	0	0	0	0	0	0	0	0
2	0	0	0	0	0	0	0	0	0	0	0	0
3	2.21*	0.47*	1.06*	2.59*	20.08 <sup>#</sup>	1.08*	2.69*	4.83*	6.11 <sup>#</sup>	1.77*	5.41*	7.02*
4	2.21*	0.47*	1.06*	2.59*	20.08 <sup>#</sup>	1.08*	2.69*	4.83*	6.11 <sup>#</sup>	1.77*	5.41*	7.02*
<b>d) Generation Mix 4</b>												
1	0.34	0.41	1.57	1.39	0	0	0	0	0	0	0	0
2	0.60	0.41	2.01	2.16	0	0	0	0	0	0	0	0
3	5.23*	2.18	9.69	19.24*	2.60*	0.93*	2.77*	6.44*	3.80*	2.29*	7.52*	12.78*
4	2.21*	0.47*	1.06*	2.59*	2.60*	0.93*	2.77*	6.44*	3.80*	2.29*	8.93*	12.78*
<b>e) Generation Mix 5</b>												
1	0	0	0	0	0	0	0	0	0	0	0	0
2	0	0	0	0	0	0	0	0	0	0	0	0
3	2.21*	0.47*	1.06*	2.59*	20.08 <sup>#</sup>	1.08*	2.69*	4.83*	6.11 <sup>#</sup>	1.77*	5.41*	7.02*
4	2.21*	0.47*	1.06*	2.59*	20.08 <sup>#</sup>	1.08*	2.69*	4.83*	6.11 <sup>#</sup>	1.77*	5.41*	7.02*
<b>f) Generation Mix 6</b>												
1	0	0	0	0	0	0	0	0	0	0	0	0
2	0	0	0	0	0	0	0	0	0	0	0	0
3	2.21*	0.47*	1.06*	2.59*	20.08 <sup>#</sup>	1.08*	2.69*	4.83*	6.11 <sup>#</sup>	1.77*	5.41*	7.02*
4	2.21*	0.47*	1.06*	2.59*	20.08 <sup>#</sup>	1.08*	2.69*	4.83*	6.11 <sup>#</sup>	1.77*	5.41*	7.02*
<b>g) Generation Mix 7</b>												
1	0	0	0	0	0	0	0	0	0	0	0	0
2	0	0	0	0	0	0	0	0	0	0	0	0
3	2.21*	0.47*	1.06*	2.59*	20.08 <sup>#</sup>	1.08*	2.69*	4.83*	6.11 <sup>#</sup>	1.77*	5.41*	7.02*
4	2.21*	0.47*	1.06*	2.59*	20.08 <sup>#</sup>	1.08*	2.69*	4.83*	6.11 <sup>#</sup>	1.77*	5.41*	7.02*
<b>h) Generation Mix 8</b>												
1	0.34	0.41	1.57	1.39	0	0	0	0	0	0	0	0
2	0.60	0.41	2.01	2.16	0	0	0	0	0	0	0	0
3	5.23*	2.18	9.69	19.24*	2.60*	0.93*	2.77*	6.44*	3.80*	2.29*	7.52*	12.78*
4	2.21*	0.47*	1.06*	2.59*	2.60*	0.93*	2.77*	6.44*	3.80*	2.29*	8.93*	12.78*
<b>i) Generation Mix 9</b>												
1	0.34	0.41	1.57	1.39	0	0	0	0	0	0	0	0
2	0.60	0.41	2.01	2.16	0	0	0	0	0	0	0	0
3	5.23*	2.18	9.69	19.24*	2.60*	0.93*	2.77*	6.44*	3.80*	2.29*	7.52*	12.78*
4	2.21*	0.47*	1.06*	2.59*	2.60*	0.93*	2.77*	6.44*	3.80*	2.29*	8.93*	12.78*
<b>j) Generation Mix 10</b>												
1	0.34	0.41	1.57	1.39	0	0	0	0	0	0	0	0
2	0.60	0.41	2.01	2.16	0	0	0	0	0	0	0	0
3	5.23*	2.18	9.69	19.24*	2.60*	0.93*	2.77*	6.44*	3.80*	2.29*	7.52*	12.78*
4	2.21*	0.47*	1.06*	2.59*	2.60*	0.93*	2.77*	6.44*	3.80*	2.29*	8.93*	12.78*
<b>k) Generation Mix 11</b>												
1	0.34	0.41	1.57	1.39	0	0	0	0	0	0	0	0
2	0.60	0.41	2.01	2.16	0	0	0	0	0	0	0	0
3	5.23*	2.18	9.69	19.24*	2.60*	0.93*	2.77*	6.44*	3.80*	2.29*	7.52*	12.78*
4	2.21*	0.47*	1.06*	2.59*	2.60*	0.93*	2.77*	6.44*	3.80*	2.29*	8.93*	12.78*
<b>l) Generation Mix 12</b>												

Table 4: Combined NDZ results with both ROCOF and G59 (UV, OV, UF, and OF) protection enabled

Furthermore, comparing sensitivity of the ROCOF method with other G59 protection modules (UV, OV, UF, OF) it can be observed that ROCOF protection has narrower NDZ in 100% of the cases under both setting option 1 and 2, whereas for options 3 and 4 it is only 23% and 10% of the cases respectively. This indicates very poor sensitivity of the ROCOF method with these higher settings and heavy reliance on other G59 modules.

The main reason for such poor ROCOF performance can be better understood by carefully analysing responses of specific islanding scenarios. These are presented in Figures 2 to 6 where frequency, ROCOF, voltage and Relay tripping signal for several generation mixes are depicted. The relay operation corresponds to combined ROCOF (Setting Option 4: 1.0 Hz/s, 0.5 Seconds) and G59 protection. For each illustrated case an LOM event is triggered at  $t = 0.5$  seconds, followed by a 3 seconds time interval in which LOM protection system should detect islanding.

In Figure 2, an LOM event for generation mix 2 (PV only) is illustrated. It can be seen that even for a small amount of imbalance (2% reactive power import) prior to LOM, the frequency quickly drifts away from nominal value. However, the drift in this case is combined with frequency oscillation which is amplified when ROCOF is derived. Although high absolute values of ROCOF are reached (in excess of 50 Hz/s), due to applied protection time delay (0.5 s in this case) there is no tripping as the relay resets at each ROCOF zero crossing point (as long as consecutive zero crossings occur within 0.5s). Eventually DG is disconnected by other G59 protection (UF). It has been observed that with the decreasing amount of directly coupled SM-based generation the frequency response gets more oscillatory, and consequently, ROCOF values reach very high levels (compare Figures). In such cases the time delay setting (if set too high) can unfortunately block the ROCOF relay operation entirely.

When three generators are included in the islanded part of the network the response (illustrated in Figures 5 and 6) is also oscillatory as it was observed for two-generator mixes, but the frequency of these oscillations appears to be much lower. Nevertheless, the time intervals between ROCOF zero crossing points are still shorter than 0.5 s, and hence, there is no tripping issued by the ROCOF relay. Voltage levels are disturbed but the excursions are not sufficient to cause voltage-dependent protection to trip.

As all generation models used in this study are equipped with AVR type controllers, voltage levels are generally stable during islanding even with relatively large amounts of reactive power imbalance. As a result voltage protection (UV and OV) is likely to be less effective. The simulation studies also confirmed this expectation. In almost 100% of the cases where NDZ was determined by G59 protection (UV, OV, UF, OF) frequency-dependent module was found to be more dependable than voltage-dependent element. The frequency protection requires less amount of power imbalance prior to LOM in order to detect islanding as all generators run under fixed real power regime (i.e. no speed regulation). Hence the NDZ for frequency protection was found to be narrower than for voltage-dependent protection.

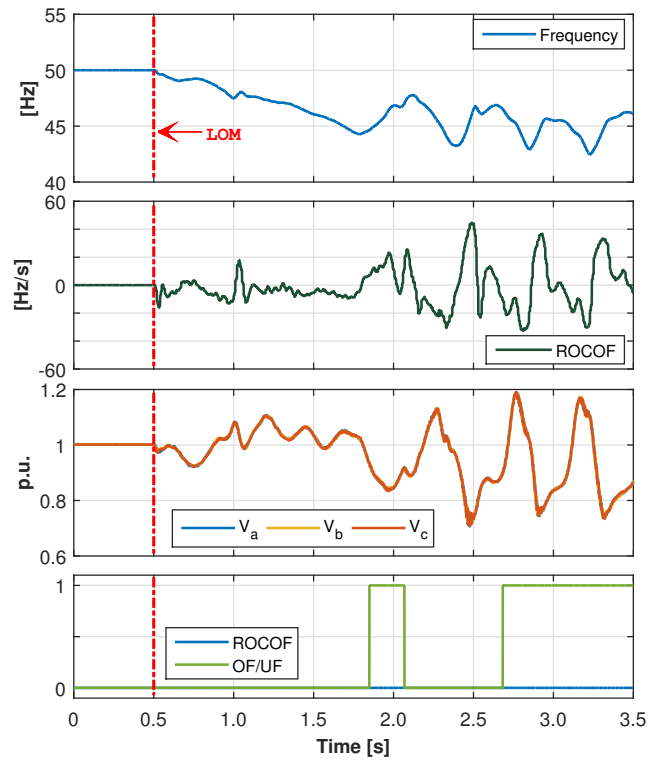

Figure 5: Frequency, ROCOF, Voltage and Relay response for Generation Mix 11 and 10% Active Power Import prior to LOM

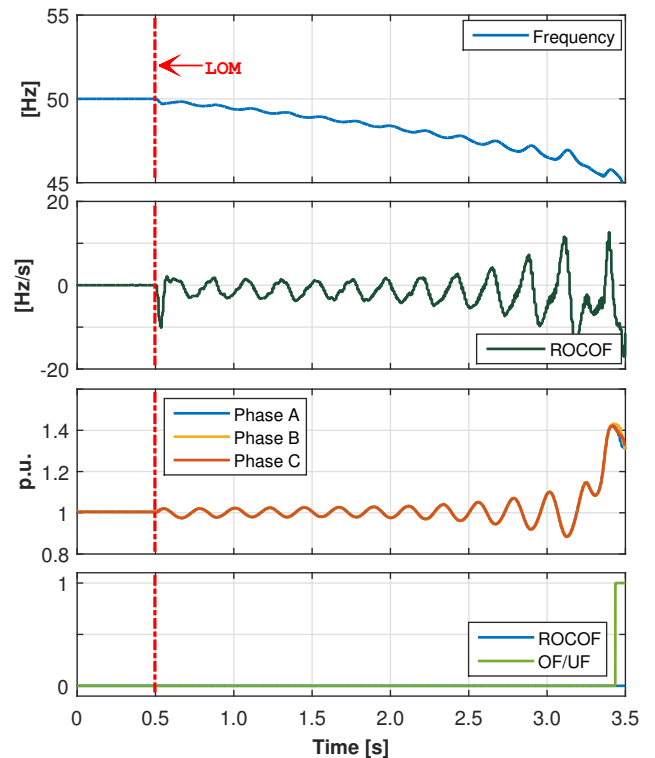

Figure 6: Frequency, ROCOF, Voltage and Relay response for Generation Mix 12 and 5% Reactive Power Export prior to LOM

## 5. Conclusions

The paper has presented a systematic assessment of the impact of multi-generator power islands on the performance of ROCOF based protection. It was discovered that ROCOF protection becomes very ineffective when protection time delay is applied. This is particularly evident with the setting option 4 (1.0 Hz/s with 500 ms delay) where ROCOF is effective only in 10% of the cases. With this setting in the majority of islanding situations the generator is disconnected by frequency-based G59 protection (as opposed to ROCOF) when considering 3 seconds as a maximum LOM detection time. This is due to the observed frequency fluctuations which lead to an oscillatory ROCOF response with certain generation mixes. It is likely that this effect is caused by the interaction of DG controllers which leads to undesired oscillations. Such response is observed especially when inverted-connected generation capacity dominates the generation mix. There are ways this phenomenon could be mitigated such as dedicated damping controllers or communication based coordination of the controllers. However, such solutions would increase the complexity and overall cost of DG integration. Alternatively, the reduction of ROCOF relay time delay setting could address such effect. However, further work is required to arrive at the best compromise time delay figure. The findings of the paper confirm that the ROCOF LOM detection method originally designed with synchronous machine dynamic response in mind (where kinetic energy of the rotor is directly coupled to the network) performs poorly with other generating technologies, especial when large proportion of inverted connected generation is present.

## Acknowledgement

The authors would like to thank National Grid and all UK DNOs for their technical and financial support for this work.

## References

- [1] F. Coffele, P. Moore, C. Booth, A. Dysko, G. Burt, T. Spearing, and P. Dolan, "Centralised loss of mains protection using iec-61850," in *Developments in Power System Protection*, March 2010, pp. 1–5.
- [2] A. Dysko, G. Burt, P. Moore, I. Glover, and J. McDonald, "Satellite communication based loss-of-mains protection," in *Developments in Power System Protection*, March 2008, pp. 687–692.
- [3] W. Freitas, W. Xu, C. Affonso, and Z. Huang, "Comparative analysis between rocof and vector surge relays for distributed generation applications," *Power Delivery, IEEE Transactions on*, vol. 20, no. 2, pp. 1315–1324, April 2005.
- [4] A. Samui and S. Samantaray, "Assessment of rocpad relay for islanding detection in distributed generation," *Smart Grid, IEEE Transactions on*, vol. 2, no. 2, pp. 391–398, June 2011.
- [5] M. Redfern, O. Usta, G. Fielding, and E. Walker, "Power based algorithm to provide loss of grid protection for embedded generation," *Generation, Transmission and Distribution, IEE Proceedings-*, vol. 141, no. 6, pp. 640–646, Nov 1994.
- [6] S. Saleh, A. Aljankawey, R. Meng, J. Meng, L. Chang, and C. Diduch, "Apparent power-based anti-islanding protection for distributed co-generation systems," *Industry Applications, IEEE Transactions on*, vol. PP, no. 99, pp. 1–1, 2015.
- [7] F. Ding, C. Booth, and A. Roscoe, "Peak-ratio analysis method for enhancement of lom protection using m-class pmus," *Smart Grid, IEEE Transactions on*, vol. PP, no. 99, pp. 1–1, 2015.

- [8] F. Liu, Y. Zhang, M. Xue, X. Lin, and Y. Kang, "Investigation and evaluation of active frequency drifting methods in multiple grid-connected inverters," *Power Electronics, IET*, vol. 5, no. 4, pp. 485–492, April 2012.
- [9] H. Vahedi and M. Karrari, "Adaptive fuzzy sandia frequency-shift method for islanding protection of inverter-based distributed generation," *Power Delivery, IEEE Transactions on*, vol. 28, no. 1, pp. 84–92, Jan 2013.
- [10] H. Zeineldin and S. Conti, "Sandia frequency shift parameter selection for multi-inverter systems to eliminate non-detection zone," *Renewable Power Generation, IET*, vol. 5, no. 2, pp. 175–183, March 2011.
- [11] X. Chen and Y. Li, "An islanding detection method for inverter-based distributed generators based on the reactive power disturbance," *Power Electronics, IEEE Transactions on*, vol. PP, no. 99, pp. 1–1, 2015.
- [12] X. Li, A. Dysko, I. Abdulhadi, and R. King, "Hardware prototype and real-time validation of the satellite communication based loss-of-mains protection," in *Developments in Power System Protection (DPSP 2014), 12th IET International Conference on*, March 2014, pp. 1–6.
- [13] D. Laverty, R. Best, and D. Morrow, "Loss-of-mains protection system by application of phasor measurement unit technology with experimentally assessed threshold settings," *Generation, Transmission Distribution, IET*, vol. 9, no. 2, pp. 146–153, 2015.
- [14] "Recommendations for setting of loss of mains protection relays," Energy Networks Association, Tech. Rep., November 2009.
- [15] A. Dysko, I. Abdulhadi, X. Li, and C. Booth, "Assessment of risks resulting from the adjustment of rocof based loss of mains protection settings - phase 1," University of Strathclyde, Tech. Rep., June 2013.
- [16] W. P. Distribution, "Generation capacity register." [Online]. Available: <http://www.westernpower.co.uk/Connections/Generation-Capacity-Map/Generation-capacity-register.aspx>
- [17] D. Sera, L. Mathe, T. Kerekes, S. Spataru, and R. Teodorescu, "On the perturb-and-observe and incremental conductance mppt methods for pv systems," *Photovoltaics, IEEE Journal of*, vol. 3, no. 3, pp. 1070–1078, July 2013.
- [18] R. Bugdal, A. Dysko, G. Burt, and J. McDonald, "Performance analysis of the rocof and vector shift methods using a dynamic protection modelling approach," in *International Conference on Power System Protection on*, 2006, pp. 139–144.
- [19] "Recommendations for the connection of generating plant to the distribution systems of licensed distribution network operators - issue 3," Energy Networks Association, Tech. Rep., August 2014.