



THE UNIVERSITY *of* EDINBURGH

Edinburgh Research Explorer

Who acquires infection from whom? Estimating herpesvirus transmission rates between wild rodent host groups

Citation for published version:

Erazo, D, Pedersen, AB, Gallagher, K & Fenton, A 2021, 'Who acquires infection from whom? Estimating herpesvirus transmission rates between wild rodent host groups', *Epidemics*, vol. 35, 100451. <https://doi.org/10.1016/j.epidem.2021.100451>

Digital Object Identifier (DOI):

[10.1016/j.epidem.2021.100451](https://doi.org/10.1016/j.epidem.2021.100451)

Link:

[Link to publication record in Edinburgh Research Explorer](#)

Document Version:

Publisher's PDF, also known as Version of record

Published In:

Epidemics

General rights

Copyright for the publications made accessible via the Edinburgh Research Explorer is retained by the author(s) and / or other copyright owners and it is a condition of accessing these publications that users recognise and abide by the legal requirements associated with these rights.

Take down policy

The University of Edinburgh has made every reasonable effort to ensure that Edinburgh Research Explorer content complies with UK legislation. If you believe that the public display of this file breaches copyright please contact openaccess@ed.ac.uk providing details, and we will remove access to the work immediately and investigate your claim.





Who acquires infection from whom? Estimating herpesvirus transmission rates between wild rodent host groups

Diana Erazo^{a,*}, Amy B. Pedersen^b, Kayleigh Gallagher^a, Andy Fenton^a

^a Institute of Infection, Veterinary, and Ecological Sciences, University of Liverpool, Liverpool, L69 7ZB, UK

^b Institute of Evolutionary Biology & Centre for Infection, Immunity and Evolution, School of Biological Sciences, University of Edinburgh, Edinburgh, EH9 3FL, UK

ARTICLE INFO

Keywords:

Disease transmission
Host classes
Apodemus sylvaticus
Herpesvirus
Disease ecology

ABSTRACT

To date, few studies of parasite epidemiology have investigated ‘who acquires infection from whom’ in wildlife populations. Nonetheless, identifying routes of disease transmission within a population, and determining the key groups of individuals that drive parasite transmission and maintenance, are fundamental to understanding disease dynamics. Gammaherpesviruses are a widespread group of DNA viruses that infect many vertebrate species, and murine gammaherpesviruses (i.e. MuHV-4) are a standard lab model for studying human herpesviruses, for which much about the pathology and immune response elicited to infection is well understood. However, despite this extensive research effort, primarily in the lab, the transmission route of murine gammaherpesviruses within their natural host populations is not well understood. Here, we aimed to understand wood mouse herpesvirus (WMHV) transmission, by fitting a series of population dynamic models to field data on wood mice naturally infected with WMHV and then estimating transmission parameters within and between demographic groups of the host population. Different models accounted for different combinations of host sex (male/female), age (subadult/adult) and transmission functions (density/frequency-dependent). We found that a density-dependent transmission model incorporating explicit sex groups fitted the data better than all other proposed models. Male-to-male transmission was the highest among all possible combinations of between- and within-sex transmission classes, suggesting that male behaviour is a key factor driving WMHV transmission. Our models also suggest that transmission between sexes, although important, wasn’t symmetrical, with infected males playing a significant role in infecting naïve females but not vice versa. Overall this work shows the power of coupling population dynamic models with long-term field data to elucidate otherwise unobservable transmission processes in wild disease systems.

1. Introduction

Understanding ‘who acquires infection from whom’ is a key challenge in epidemiology, population biology and disease ecology (Webster et al., 2017). For managing parasite species (defined here generally to include both macroparasites (i.e. helminths, ectoparasites) and microparasites/pathogens (i.e. viruses, bacteria, protozoans)) that can infect multiple host species, it is clearly important to establish both which host species play an important role in transmission (Fenton et al., 2015; Streicker et al., 2013), and specifically why and how they contribute more to transmission than other species. Rabies transmission maintenance, for example, in the Serengeti ecosystem appears to be primarily dependent on domestic dogs, although it has the potential to infect all mammals (Lembo et al., 2008). While it is clearly important to

understand transmission between different groups of species for generalist parasites, it is also true for specialist parasites that infect only a single host species that it can be important to distinguish the contribution of different host population categories, such as age and sex classes, to determine which behaviours and groups are driving infection (Anderson and May, 1991). For instance, a study of bank vole populations in north west England showed that cowpox virus-infected females might be a more important source of infection to either sex than are males (Carslake et al., 2006). However, it can be notoriously difficult to identify routes of disease transmission and the key individuals or groups driving transmission in natural populations, which has limited our knowledge about who acquires infection from whom for many wildlife diseases.

Sex-biased parasitism has been studied in several vertebrate systems,

* Corresponding author.

E-mail address: erazodiana1@gmail.com (D. Erazo).

<https://doi.org/10.1016/j.epidem.2021.100451>

Received 7 October 2020; Received in revised form 10 February 2021; Accepted 10 March 2021

Available online 13 March 2021

1755-4365/© 2021 The Author(s). Published by Elsevier B.V. This is an open access article under the CC BY license (<http://creativecommons.org/licenses/by/4.0/>).

suggesting that males usually have higher parasite prevalence compared to females (McCurdy et al., 1998; Moore and Wilson, 2002; Schalk and Forbes, 1997). Nonetheless, these findings do not provide insight on the dynamics of infection in the population, particularly on how parasites flow within and between different demographic groups in the population. Translating 'infection' biases at the individual level to 'transmission' biases at the population level could provide behavioral and physiological hypotheses, having implications for understanding risk to other classes, identifying super-spreader groups or predicting consequences of changes to population age or sex structure for disease spread. However, this can be a difficult task, requiring challenging field experiments, such as carried out Ferrari et al. (2004) in which helminths were reduced in either males or females in yellow necked mice and then monitored in the untreated sex. Often such experimental methods are not logistically feasible, in which case alternative approaches for identifying transmission pathways within wildlife populations are needed. The fitting of mechanistic mathematical models to population-wide infection data may be a valuable way to do this.

Gammaherpesviruses are a widespread group of DNA viruses that infect vertebrates, including humans, and can lead to persistent infections (Davison, 2002). Gammaherpesviruses are largely host-specific (Nash et al., 2001a), and as such murine gammaherpesviruses, such as murid herpesvirus 4 (MuHV-4, of which MHV-68 is the archetypal strain) have been commonly used in inbred laboratory mice (*Mus musculus*) as standard models for understanding gammaherpesvirus infection biology more generally (Pedro Simas and Efstathiou, 1998; Sunil-Chandra et al., 1992). However, while the mechanisms of pathogenesis and immune interactions within individual hosts have been well studied (Nash and Sunil-Chandra, 1994; Pedro Simas and Efstathiou, 1998), for instance it is well known that infection fluctuates between acute and latent infection stages, but only acute individuals transmit the virus (Nash et al., 2001b), little is known about the routes of transmission in either the laboratory setting or in natural host populations.

It is widely considered that gammaherpesviruses are transmitted through close contact (Wald and Corey, 2007). Furthermore, male presence and natural behaviour could be critical in herpesvirus transmission (Knowles et al., 2012), leading to the hypothesis that infection could occur through sexual contact and/or aggressive behaviours such as biting and scent marking behaviour (Knowles et al., 2012; Telfer et al., 2007). The route of transmission, and the behaviour involved, have important implications for how transmission likely scales with population size. If strict sexual transmission is the main driver of murine gammaherpesviruses infection, we would expect transmission to be mainly frequency-dependent, because individuals generally do not have a greater number of sexual contacts in higher-density populations (Keesing et al., 2006; May and Anderson, 1987). However, if transmission is primarily driven by male dominance behaviours then transmission may be primarily density-dependent. Thus, if male dominance behaviour is maintaining herpesvirus infection in wild rodent populations it is likely that transmission: i) depends mostly on male density, particularly reproductive males, and ii) occurs mainly before breeding season when reproductively active males are establishing territories, and the number of contacts with other reproductive males increases. Although previous studies (Knowles et al., 2012; Telfer et al., 2007) suggest an asymmetrical role of males in herpesvirus transmission, uncertainty remains about what are the key disease transmission routes and the contribution of each population category.

To elucidate key aspects of transmission biology which would be otherwise hard to identify, mechanistic model fitting to data can be a useful tool that aids detection and quantification of potential transmission routes (Baguelin et al., 2020). The inference of infectious disease dynamics using mathematical models has been widely used in epidemiology and recognized as an invaluable tool for the interpretation and analysis of existing epidemiological data (Becker et al., 2021; Funk and King, 2020). Here, we make use of model fitting to data to investigate WMHVs transmission dynamics within its natural host population

by fitting a series of mechanistic models to 4-years of longitudinal serological data from a wild population of the wood mouse, *Apodemus sylvaticus*. Each model reflects the above-mentioned hypotheses about the transmission processes within and between demographic groups by incorporating different combinations of host sex (male/female), age (subadult/adult) and transmission mechanisms (density/frequency-dependent). We compare models based on the best fit and analyse the estimated parameters, including the different group contributions to the overall reproductive number (R_0) of the virus. Finally, we discuss the implications of our results in the context of WMHV infection, aiming to shed light on its natural transmission mechanism.

2. Methods

A series of mathematical models were fitted to previous longitudinal data on mice captured in Haddon Wood, Cheshire, UK in a four-year experiment. First, we fitted a demographic model to the observed mouse population dynamic data, and in doing so estimated the key demographic parameters of the host. Second, using that demographic framework as a baseline, we fitted four mathematical models to the WMHV serological data, each capturing different potential aspects of WMHV transmission. The quality of fits among these competing models were compared using the total Deviance Information Criterion (DIC). Finally, using the epidemiological parameters for the best-fitting model, we derived an estimate of the overall basic reproductive number and partitioned that value into class contributions.

2.1. Field data

Serological data from longitudinal, repeat sampling of wood mice (*Apodemus sylvaticus*) collected between June 2009 and December 2012 in four grids located in Haddon Wood, Cheshire, UK as described in (Knowles et al., 2012). The total trapping area spanned ~ 650 m, with the centre points of pairs of grids being ~ 100 – 200 m. Vegetation and ground cover was similar across all grids. Two Sherman live-traps were baited with grain and bedding and placed every 10 m in each 70×70 m squared grid. Trapping was conducted for 3 consecutive nights every 3 weeks during four annual field seasons: June–December in 2009 and 2012, and May–December in 2010 and 2011. All trapped individuals were tagged with a unique passive integrated transponder (PIT) tag for recognition in subsequent recaptures. From all wood mice, morphometric measures were recorded, including sex and age (juvenile, sub-adults, and adult), and blood samples were taken from the tail at first capture within each month for serological analyses. We used a serological assay that detects WMHV antibodies in mouse serum using IFA (Knowles et al., 2012). Since maternal antibodies to WMHV persist into young adulthood, we excluded juveniles from our analysis.

2.2. Models

We fit a series of mathematical models to the serological data, each capturing different potential aspects of WMHV transmission (see below). All models used the same demographic framework to describe the wood mouse population dynamics, against which WMHV transmission occurred (i.e., mouse population dynamics were assumed to be independent of viral infection dynamics, implying a negligible impact of infection on host survival or reproduction). Hence, we first fitted a demographic model to the observed mouse population dynamic data, and in doing so estimated the key demographic parameters (birth rates, survival rates and carrying capacities) for our specific system. For this demographic component, we constructed a two-equation model representing wood mice population dynamics, as follows:

$$\frac{dJ}{dt} = b(t)M \frac{(K(y) - N)}{K(y)} - (\mu + \lambda)J \quad (1)$$

$$\frac{dM}{dt} = \lambda J - \mu M \tag{2}$$

where J represents the juvenile and sub-adult mice combined, M the adult mice, N the total mice population size, $K(y)$ the carrying capacity in year y , $b(t)$ the birth rate, μ the mortality rate and λ the maturation rate. Wood mice population dynamics are highly seasonal in UK woodlands, thus we defined birth rate as a function of time, as follows:

$$b(t) = \left| b_0 \sin 2\pi \left(\frac{t}{52} - \omega \right) \right| + b_0 \sin 2\pi \left(\frac{t}{52} - \omega \right)$$

where t is time in weeks, b_0 is the baseline birth rate, ω is the birth function phase (which sets the timing of peak births). This construction means $b(t)$ is periodic with a period of 1 year, allowing for a 6-month-long breeding season and 6 months outside that period of no reproduction which fits patterns of breeding in the field sites. The carrying capacity, $K(y)$, was also assumed to vary for each of the four years of our study, to account for year-to-year fluctuations in overall mouse population size, dependent on seasonal environmental factors (e.g. resources or abiotic conditions); hence we assumed different values of $K(y)$ for each year, which we estimated through model fitting (see below).

Having estimated the relevant parameters to describe the wood mouse population dynamics, we then used that demographic model as a baseline for the construction of four herpesvirus epidemiological models, which we fitted to the observed serological data, estimating the key epidemiological parameters in the process. These models accounted for previous findings that suggest WMHV and the related MuHV-4 infection are sex- and age-differentiated (Knowles et al., 2012; Telfer et al., 2007), and hence different age and sex classes may contribute differently to transmission. The basic herpesvirus model (Fig. 1A) consisted of a three-equation system with susceptible, active, and latent classes, and just one age class (i.e., the adult/sub-adult distinction from Eq. (1) is subsumed into a single equation of overall host dynamics):

$$\frac{dS}{dt} = b(t) N \frac{(K - N)}{K} - \beta SA - \mu S \tag{3}$$

$$\frac{dA}{dt} = \beta SA + \eta L - \varepsilon A - \mu A \tag{4}$$

$$\frac{dL}{dt} = \varepsilon A - \eta L - \mu L \tag{5}$$

Susceptible individuals (S) become infected and enter the active

infection class (A) through contact with active-infected individuals (latent-infected individuals are assumed not to transmit infections) at transmission rate β . Active-infected individuals then move to the latent class (L) at transition rate ε (hence active infections last on average $1/\varepsilon$ weeks), and vice versa at rate η (hence latent infections last on average $1/\eta$ weeks). Based on existing knowledge about gammaherpes viruses (Nash et al., 2001a) it is assumed individuals do not recover from infections. All individuals, whether uninfected, active infected or latent-infected, were assumed to die at the same rate μ .

Using the above framework as a baseline, we developed a series of alternative formulations that incorporated potential transmission pathways for each specific demographic group in the population, and different formulations of the transmission functions. The first model (six demographic groups with density-dependent transmission: 6-group DD) considered explicit female and male classes (Fig. 1B) and density-dependent transmission for all possible transmission routes ($\beta_1 - \beta_4$). Therefore, the model consisted of six groups (susceptible, active-infected and latent-infected, for both females and males), and all transmission terms had the form $\beta_n S_i A_j$ where i and j represent sex, either female or male, and β_n is the transmission rate between i and j . The second model (six group frequency-dependent transmission: 6-group FD) had the same structure as the 6-group DD model but considered frequency-dependent transmission (as is often assumed for sexually transmitted infections; (Keesing et al., 2006)), thus the transmission terms had the form $\frac{\beta_n S_i A_j}{N}$. The third (nine group density-dependent transmission: 9-group DD) and fourth (nine group frequency-dependent transmission: 9-group FD) models accounted for age-dependent transmission by explicitly incorporating a subadult class into the above framework, along with female and male adult classes (Fig. 1C). Based on our previous results (Knowles et al., 2012), we assumed that male and female subadults do not differ in terms of transmission potential or susceptibility, and so were combined into a single class. Subadults were assumed to mature to adults at rate λ (see demographic model, above), half becoming adult males and half adult females. This structure therefore introduced five additional possible transmission routes involving the subadults, resulting in nine transmission parameters ($\beta_1 - \beta_9$) overall. As with 6-group DD and 6-group FD models, 9-group DD and 9-group FD models differed by their transmission function; 9-group DD used density-dependent transmission for all transmission rates ($\beta_n S_i A_j$) and 9-group FD used frequency-dependent transmission for all transmission rates ($\frac{\beta_n S_i A_j}{N}$). See Tables 1A and 1B for a description of all parameters in all models.

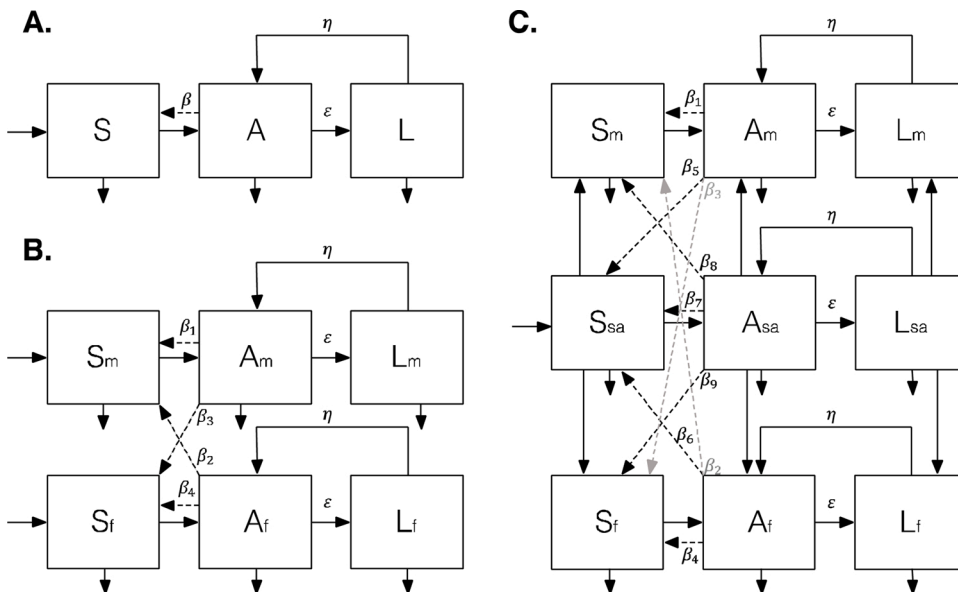

Fig. 1. Herpesvirus models. A) Basic model. B) Sex-explicit models: six group density-dependent model (6-group DD) and six group frequency-dependent model (6-group FD). C) Sex- and age-explicit models: nine group density-dependent model (9-group DD) and nine group frequency-dependent model (9-group FD). Susceptible individuals (S) become infected and enter the active infection class (A) through contact with active-infected individuals at transmission rate β . The start point of the arrow defines the active-infected individual group. Active-infected individuals then move to the latent class (L) at transition rate ε , and vice versa at rate η . The different β_i specify different potential transmission rates between the various demographic classes in the relevant models.

2.3. Model parameterization, fitting and comparison

Demographic parameters ($\theta_1 = \{K, \mu, \lambda, b_0, \omega\}$) and disease-related parameters ($\theta_2 = \{\beta_1 \dots \beta_9, \epsilon, \eta\}$) were estimated using adaptive Monte Carlo Markov Chain Metropolis-Hastings (MCMC-MH), assuming uniform priors (Table 1A), through fitting to data on mouse population abundance and infection seroprevalence respectively. Uniform priors were assumed because little is known about the parameters distributions. For instance, regarding the duration of acute and latent infections, most experimental studies end after a few weeks, and virus reactivation is not likely because it relies mainly on stressors (i.e., becoming infected with worms and adverse weather). Thus, we assumed that acute to latent transition rate (ϵ) and vice versa (η) could range between 0 and 1, meaning that the transition from one state to the other could take from 1 week to a lifetime. We ignored the first year (52 weeks) of predicted transient dynamics of the simulation as burn-in time and fit the models over the subsequent 4 years of data. This procedure was done to ensure the model was fitted to the data when the simulations reached a steady state.

As described above, model fitting was carried out in two stages. First, demographic parameters and yearly carrying capacities were estimated by fitting the simulated total number of weekly mice ($I_{mice}; J + M$ from Eqs. (1) and (2)) to the observed number of mice captured per week (y_{week}). The weekly number of mice captured was assumed to follow a Poisson distribution. The log-likelihood of the data for the mice population dynamics model was given by:

$$l_{mice}(\theta_1) = l_{mice}(data\theta_1) = \sum_{week} l_{mice-week}(y_{week}|\theta_1)$$

Through this we generated posterior distributions for the 4 year-specific carrying capacities (2009–2012), baseline birth rate and birth function phase.

Next, we sought to estimate the different transmission parameters in the various models. For model fitting to data the simulated WMHV prevalence of wood mice in each demographic group (proportion of animals infected per group each week) was contrasted to the observed prevalence in each group per week; since the data on infection status were based on a serological assay, which cannot differentiate active from latent infections, we combined the predicted prevalences in the A and L classes (Eqs. (4) and (5)) to calculate an overall expected prevalence of infection in each group (e.g., the proportion of predicted

Table 1A

Parameters and values used in the demographic model. Estimated values show median and 95 % credible intervals from the posterior distributions of each parameter.

Symbol	Parameter description	Baseline value	Prior distribution	Estimated value
b_0	Birth function scale	0.5	0.5 – 20	0.539 [0.538 – 0.540]
ω	Birth function phase	0.15	0 – 1	0.0148 [0.0145 – 0.0151]
μ	Mice mortality rate	0.04	0 – 1	0.0596 [0.0595 – 0.0597]
λ	Maturation rate	0.1	0 – 1	0.102 [0.101 – 0.103]
$K(1)$	Carrying capacity in year 1	50	25 – 100	81.3 [81.2 – 81.4]
$K(2)$	Carrying capacity in year 2	50	25 – 100	56.8 [56.7 – 56.9]
$K(3)$	Carrying capacity in year 3	50	25 – 100	95.5 [95.4 – 95.6]
$K(4)$	Carrying capacity in year 4	50	25 – 100	69.2 [69.1 – 69.3]

infected males was given as $(A_{male} + L_{male}) / (S_{male} + A_{male} + L_{male})$). Observed weekly prevalence was assumed to follow a binomial distribution. The overall log-likelihood of the data for the first and second model (only females and males) was given by:

$$l_{all}(data\theta_2) = \sum_{week} l_{males-week}(y_{week}|\theta_2) + \sum_{week} l_{females-week}(y_{week}|\theta_2)$$

The overall log-likelihood of the data for the third and fourth model was given by:

$$l_{all}(data\theta_2) = \sum_{week} l_{subadults-week}(y_{week}|\theta_2) + \sum_{week} l_{females-week}(y_{week}|\theta_2) + \sum_{week} l_{males-week}(y_{week}|\theta_2)$$

Through this we generated posterior distributions for disease-related parameters (the relevant transmission rates, β_i , and the transition rates, ϵ and η).

For each model, we ran four MCMC-MH chains of 10,000 iterations using the default parameter standard deviation (parameter value divided by 10). Then, for each chain, using the first chain output (standard deviation and $\bar{\theta}$ for the last 9,000 iterations) as input, we ran a second chain of 100,000 iterations. For the second chain, the first 5,000 iterations were discarded (burn-in), and we eliminated every 10 samples per sample to avoid auto-correlation (thin). An example to demonstrate the input and output of this step can be found in the Supplementary Materials. The Gelman-Rubin diagnostic was used to assess MCMC convergence by analysing the difference between chains for each model. Thinned and burned chains were combined for comparison between the herpesvirus models.

Herpesvirus models (6-group DD, 6-group FD, 9-group DD and 9-group FD) were compared using the total Deviance Information Criterion (DIC) for each model; the model with the lowest DIC values corresponds to the best model. Having estimated the epidemiological parameters for the best-fitting model, we used those values to derive an estimate of the overall basic reproductive number, $R_{0,tot}$ using the next generation method of Diekmann et al. (2010), and partitioned that value into the contributions of males and females, respectively.

All model fitting and comparisons were carried out using R version 3.5.1 and the RStudio Integrated Development Environment (IDE) (R Development Core Team, 2016). Adaptive Monte Carlo Markov Chain Metropolis-Hastings (MCMC-MH) was conducted using the fitR package (Camacho and Funk, 2019) and outputs were analysed using the coda package (Plummer et al., 2006).

3. Results

Overall during the four-year field sampling, 1,394 mice were captured a total of 4,316 times, with a mean number of captures per mouse of 3.04 (range 1–28). A total of 1,343 mice were identified as subadults or adults and were captured 4,197 times. The remaining 51 mice were identified as juveniles. The number of subadult and adult mice considered in this study were 1,065, for a total of 1,817 samples. Captures with missing data or that did not have blood sample taken, were not considered. Overall, 15.4% animals were seropositive for WMHV, with a significant difference in WMHV incidence between the sexes (0.1 of female captures were seropositive, compared to 0.19 of male captures; $X^2 = 19.79, p < 0.001$).

Regarding the estimation of demographic parameters, the birth function scale (b_0) and phase (ω) were estimated to be 0.539 and 0.0148, respectively, implying on average 17.8 offspring per individual per breeding season and that the population is expected to increase at the beginning of the field season, corresponding well to the observed trends in the data (Fig. 2). We estimated that mean wood mouse life expectancy was approximately 17 weeks ($\mu = 0.0596$ [0.0595 – 0.0597] week⁻¹) and mean maturation time to sexually reproductive status was around

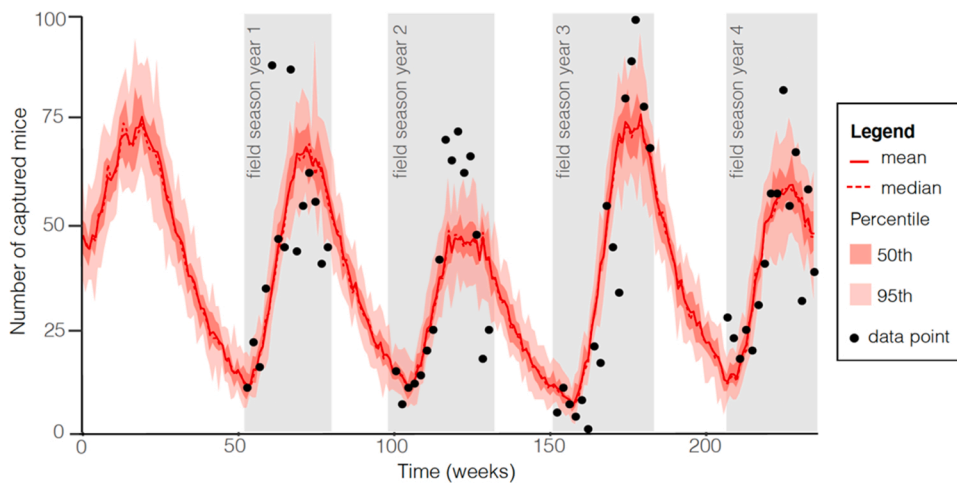

Fig. 2. Demographic model fit to data. *X*-axis is time in weeks from the start of the simulation (the first 52 weeks were excluded in model fitting as burn-in time), and *y*-axis is number of captured mice. Dots represent data points and grey shaded regions cover the period in which fieldwork was conducted. Model simulation mean and median are shown by the red solid and dashed lines, respectively. Pink and red shades represent 50th and 95th percentile of the simulations. (For interpretation of the references to colour in this figure legend, the reader is referred to the web version of this article).

10 weeks ($\lambda = 0.102 [0.101 - 0.103] \text{ week}^{-1}$) The highest estimated carrying capacity corresponded to the third field season (2011) with 95 mice, followed by the first and fourth field seasons (2009 and 2012) with 81 and 69 mice, respectively. The lowest carrying capacity was estimated for the second field season (2010) with 57 mice. See Table 1A for 95 % credible intervals from the posterior distributions of demographic parameters.

The best-fitting transmission model by DIC (Table 2) incorporated both female and male classes explicitly, but not subadults, and assumed density-dependent transmission (*6-group DD* model). These results suggest that the most accurate and parsimonious description of the observed patterns of WMHV transmission in these wood mouse populations requires explicit description of transmission within and between the two sexes, but accounting for age-varying transmission processes was not necessary. This best-fitting model showed good agreement with the observed weekly prevalence for both adult females and males (Fig. 3), capturing the observed infection peaks during the four seasons, for females and males during June 16 of 2009 (week 53), June 1 – June 29 of 2010 (weeks 103–107), June 14 of 2011 (only males, week 157), and July 3–31 (weeks 212–216). Interestingly, the third field season (2011) showed the lowest infection peak and the highest carrying capacity among seasons, and the second season had the lowest estimated carrying capacity. An increase in prevalence was observed between December to May-June for males and females in the data and the model simulation (Fig. 3), except females from year 2 to year 3 (2010–2011), because at the beginning of year 3, the number of infected females was

zero. The fitting of alternative models can be found in the Supplementary Materials.

Among the estimated transmission rates for the best-fitting model ($\beta_1 - \beta_4$), transmission from males dominated; male-to-male transmission was the highest ($\beta_1 = 0.00789 [0.00786 - 0.00791]$) Table 1B, followed by male to female transmission ($\beta_3 = 0.00322 [0.00321 - 0.00323]$). Conversely, transmission from females, either to males ($\beta_2 = 0.00091 [0.00090 - 0.00092]$) or to other females ($\beta_4 = 0.00167 [0.00165 - 0.00169]$), was very low and on average 77 % lower compared to transmission from males. The estimated transition from active to latent infection was rapid ($\eta = 0.624 [0.627 - 0.621]$ per week), implying a median duration of the initial active infection phase of ~ 1.6 weeks. The estimated median transition time back from latent to active infection was ~ 2.5 weeks ($\epsilon = 0.403 [0.4 - 0.406]$ per week). Parameter estimates for the other herpesvirus models can be found in Table 1B.

Using the *6-group DD* model estimated values we assessed the contribution of males and females to the overall basic reproductive number ($R_{0,tot}$) for WMHV. Following Diekmann et al. (2010), we calculated an expression for the *6-group DD* model $R_{0,tot}$ using the next generation matrix (NGM) approach (Diekmann et al., 2010), where $R_{0,tot}$ is represented the dominant eigenvalue of a matrix resultant from the multiplication of the transmission and the transition matrix. The transmission matrix T represented the production of new infections as follows:

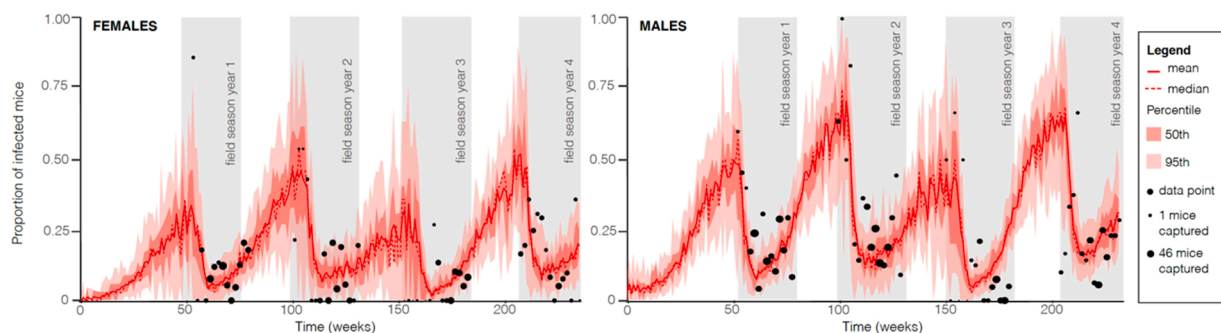

Fig. 3. Six group density-dependent model (*6-group DD*) fit to data. Left and right panels show model fit to female and male data, respectively. *X*-axis is time in weeks from the start of the simulation (first 52 weeks were excluded in model fitting as burn-in time) and *y*-axis is herpesvirus seroprevalence (proportion seropositive); for the simulation these comprised both acute and latent infections). Dots represent data points and dot size illustrates the number of mice captured at each data point. Areas in grey shade show the period in which fieldwork took place. Model simulation mean and median are shown by the red solid and dashed lines, respectively. Pink and red shades represent 50th and 95th percentile of the simulations. (For interpretation of the references to colour in this figure legend, the reader is referred to the web version of this article).

Table 1B

Parameters and values used in the four herpesvirus models: 6-group DD and 6-group FD, 9-group DD and 9-group FD. Values show median and 95 % credible intervals from the posterior distributions of each parameter.

Symbol	Parameter description	Baseline value	Prior	Model 1 6-group DD DIC: 463	Model 2 6-group FD DIC: 792	Model 3 9-group DD DIC: 827	Model 4 9-group FD DIC: 774
ϵ	Active to latent transition rate	0.25	0 – 1	0.624 [0.627 – 0.621]	0.0067 [0.0066 – 0.0068]	0.875 [0.874 – 0.876]	0.0066 [0.0065 – 0.0067]
η	Latent to active transition rate	0.25	0 – 1	0.403 [0.400 – 0.406]	0.641 [0.638 – 0.644]	0.0987 [0.0983 – 0.0991]	0.602 [0.599 – 0.605]
β_1	Male to male transmission rate	1×10^{-3}	0 – 0.1	0.00789 [0.00786 – 0.00791]	0.09845 [0.09844 – 0.09846]	0.0147 [0.0146 – 0.0148]	0.09802 [0.09800 – 0.09804]
β_2	Female to male transmission rate	1×10^{-3}	0 – 0.1	0.00091 [0.00090 – 0.00092]	0.09719 [0.09716 – 0.09722]	0.0349 [0.0346 – 0.0352]	0.09569 [0.09564 – 0.09574]
β_3	Male to female transmission rate	1×10^{-3}	0 – 0.1	0.00322 [0.00321 – 0.00323]	0.0944 [0.0943 – 0.0945]	0.00405 [0.00402 – 0.00408]	0.08798 [0.08784 – 0.08813]
β_4	Female to female transmission rate	1×10^{-3}	0 – 0.1	0.00167 [0.00165 – 0.00169]	0.0516 [0.0515 – 0.0518]	0.00566 [0.00561 – 0.00570]	0.03756 [0.03724 – 0.03789]
β_5	Male to sub-adult transmission rate	1×10^{-3}	0 – 0.1	–	–	0.0170 [0.0169 – 0.0171]	0.09302 [0.09295 – 0.09309]
β_6	Female to sub-adult transmission rate	1×10^{-3}	0 – 0.1	–	–	0.0279 [0.0276 – 0.0281]	0.0661 [0.0658 – 0.0664]
β_7	Sub-adult to sub-adult transmission rate	1×10^{-3}	0 – 0.1	–	–	0.00558 [0.00554 – 0.00562]	0.0643 [0.0641 – 0.0645]
β_8	Sub-adult to male transmission rate	1×10^{-3}	0 – 0.1	–	–	0.00392 [0.00388 – 0.00396]	0.0753 [0.0750 – 0.0755]
β_9	Sub-adult to female transmission rate	1×10^{-3}	0 – 0.1	–	–	0.00320 [0.00317 – 0.00324]	0.04152 [0.04119 – 0.04185]

Table 2

DIC values comparing model fits for each demographic group, and overall, for the four fitted models.

	Female	Male	Sub-adults	Total
Model 1: six group density-dependent transmission	179	298	-	463
Model 2: six group frequency-dependent transmission	491	609	-	792
Model 3: nine group density-dependent transmission	250	486	116	828
Model 4: nine group frequency-dependent transmission	409	519	320	774

$$T = \begin{vmatrix} \beta_1 S_{male} & 0 & \beta_2 S_{male} & 0 \\ 0 & 0 & 0 & 0 \\ \beta_3 S_{female} & 0 & \beta_4 S_{female} & 0 \\ 0 & 0 & 0 & 0 \end{vmatrix}$$

and the transition matrix Σ , describing changes in state (including death), was given by:

$$\Sigma = \begin{vmatrix} -(\epsilon + \mu) & \eta & 0 & 0 \\ \epsilon & -(\mu + \eta) & 0 & 0 \\ 0 & 0 & -(\epsilon + \mu) & \eta \\ 0 & 0 & \epsilon & -(\mu + \eta) \end{vmatrix}$$

$R_{0,tot}$ is then dominant eigenvalue of the next generation matrix approach given by $-T\Sigma^{-1}$:

$$R_0 = \frac{(\mu + \eta) \left(\beta_1 S_{male} + \beta_4 S_{female} + \sqrt{(\beta_1 S_M - \beta_4 S_F)^2 + 4\beta_2\beta_3 S_{male} S_{female}} \right)}{2\mu(\epsilon + \eta + \mu)}$$

Assuming a 1:1 female:male ratio, the total number of mice as the mean carrying capacity over the four-year period ($\bar{K} = 75$), and replacing with the estimated values from the best-fitting 6-group DD model (Table 1B), we estimated $R_{0,tot}$ as 2.1299 [2.1290, 2.1307]

Finally, we partitioned $R_{0,tot}$ into the contributions of males and females by setting either the male-onward (β_1 and β_2) or female-onward

(β_3 and β_4) transmission rates to 0. In other words, this procedure calculated R_0 when either males or females contributed nothing to transmission, resulting in: $R_{0,males} = 2.0133$ [2.011 – 2.0153] and $R_{0,females} = 0.4222$ [0.4186 – 0.4276]. Note that, since there are individuals that could get infected by both groups, leading to potential overlaps in transmission, $R_{0,males}$ and $R_{0,females}$ do not simply add up to

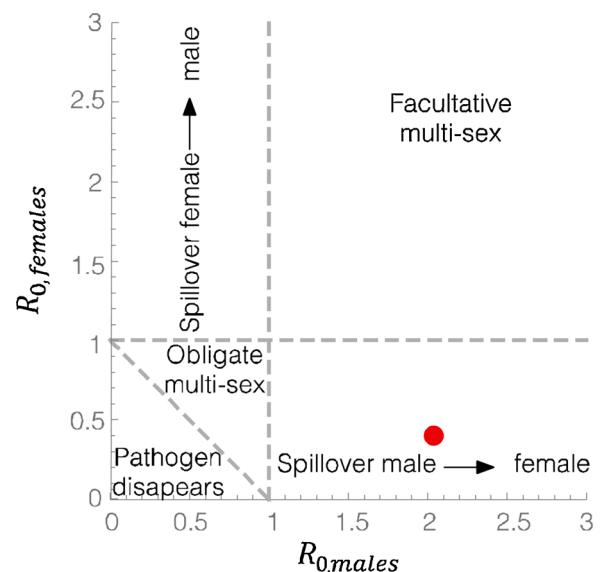

Fig. 4. $R_{0,males} - R_{0,females}$ parameter space. Based on the framework by Fenton et al (2015), the figure has five regions, each representing a potential disease outcome: parasite exclusion, spillover from male to female, spillover from female to male, facultative multi-sex (either group can maintain the pathogen), and obligate multi-sex (both groups are required to maintain the pathogen). The red dot represents the estimated value for $R_{0,males}$, $R_{0,females}$ (2.01, 0.42) for the WMHV system, using parameters from the best-fitting 6-group DD model, predicting that males maintain WMHV in the system, with spillover occurring from males to females. (For interpretation of the references to colour in this figure legend, the reader is referred to the web version of this article).

$R_{0,tot}$. Following the conceptual framework of Fenton et al. (2015), and using these $R_{0,males}$ and $R_{0,females}$ values, Fig. 4 shows that males can maintain WMHV on their own, and infections in females are primarily due to spillover from males to females.

4. Discussion

Identifying both the routes of disease transmission, and the key individuals or groups that drive transmission in natural populations, is notoriously hard (Antonovics, 2017; Lello and Fenton, 2017). One way to identify and quantify potential transmission routes is through the fitting of mechanistic models to epidemiological data, where we can estimate the magnitude of possible transmission-relevant parameters in the process (Baguelin et al., 2020). Using model fitting to data for inferring infectious disease dynamics is a well-known tool in epidemiology that could be applied to several ecological systems, particularly to those where high-resolution longitudinal data is available. Examples of inference methods applied to disease dynamics include accounting for the incubation period to infer transmission from data on bovine spongiform encephalopathy (BSE) (Donnelly et al., 2003) and using data augmentation to account for asymptomatic or undetected SARS transmission (Cauchemez et al., 2006). Here we built a series of epidemiological models of wood mouse herpesvirus (WMHV) transmission, each reflecting different hypotheses about the transmission processes within and between demographic groups in wild populations of the wood mouse, *Apodemus sylvaticus*, based on our previous results (Knowles et al., 2012). We show that WMHV dynamics are dominated by transmission from males, particularly male-to-male transmission, and that it is likely that males can maintain the virus on their own, with females being little more than a ‘spillover’ group, playing a very small role in transmission in its natural host.

Despite being a standard model of herpesvirus infection biology and immunology in the laboratory, how WMHV and related viruses (e.g., MHV-68) transmit in the wild has been a long-standing mystery. It was generally believed that gammaherpesviruses transmit through close contact (Wald and Corey, 2007). However, previous research in laboratory studies in which infected and uninfected female mice were kept together in the same cage failed to result in transmission (François et al., 2010), suggesting that infection does not seem to happen through inhalation of virus particles suspended in the air. As such it has been suggested that the presence of males and their associated natural behaviours could be important in viral transmission, with possibly transmission occurring through sexual contact. For example, François et al. (2013) experimentally demonstrated herpesvirus transmission from infected females to naive males after sexual contact but not vice versa. In contrast, an experiment with a different type of virus, Sin Nombre hantavirus, showed that natural transmission among mice in cages was uncommon and only occurred among males, but not females or between sexes (Botten et al., 2002). We suggest that if WMHV and related viruses transmission routes are ever to be identified, captive studies need to include both males and females, and potentially allow for ‘natural’ behaviours as much as possible, in their experimental designs.

Our results, which quantify natural transmission rates in the wild, confirm the importance of males for driving herpesvirus infection; the highest transmission rate related to males infecting other males, followed by male-to-female transmission. Male dominance in parasite transmission has been reported in multiple rodent - parasite systems (i.e. *Heligmosomoides polygyrus*, Tick borne encephalitis virus) (Ferrari et al., 2004; Perkins et al., 2003). This dominance of males in driving transmission may arise from physiological (i.e. hormonal or immune-mediated) processes, behavioural differences, or both. Suppression in immune responses are known to be a product of testosterone increases in reproductive males (Klein, 2004, 2000; Saino et al., 2000). In terms of behavioural explanations, previous studies on rodent viral infections have shown a higher prevalence in males for hantavirus

(Abbott et al., 1999) and cowpox (Hazel et al., 2000), and it has been proposed that those differences are due to higher territorial aggression and travel distances in males. Thus, male dominance behaviours, such as scent-marking and biting, may constitute important transmission routes via urine and saliva, respectively. Laboratory experiments highlight the nose as an important point of viral entry (Milho et al., 2009), because among inoculation routes, intranasal is highly effective for infecting mice (Hricová and Mistríková, 2008). Since WMHV prevalence in wood mice seems to be independent of breeding season (Telfer et al., 2007) and previous studies have concluded that scent marking, at least in voles, could also convey identity and the frequency of scent marking was not always related to mate choice (Thomas and Wolff, 2002; Wolff, 2007); scent-marking behaviour could be the main transmission route (Knowles et al., 2012). As such we note that the relatively high rates of male to female transmission that we observe does not have to be due specifically to sexual contact but also scent-marking behaviour, since the latter is used to advertise current reproductive condition, attract mates, or merely individual identification (Thomas and Wolff, 2002; Wolff, 2007).

To support the suggestion that transmission in these natural populations is not driven by sexual contacts, we found that a density-dependent transmission function best fit the observed seroprevalence patterns. This implies that frequency-dependent transmission, typically assumed for sexually transmitted pathogens (Thrall et al., 1993), was not driving herpesvirus infection in this population. In addition, theory predicts that sexually transmitted infections would be female biased due to a higher variance in mating success among males (Thrall et al., 2000), therefore exclusively sexual transmission is unlikely in polyandrous species, such as the wood mouse (Booth et al., 2007). Since previous research has emphasized that WMHV in wild wood mice shows no strong density-dependent patterns (Telfer et al., 2007), if prevalence is male biased and infection is density-dependent, then transmission is likely to be related to the density of the high-risk group, rather than of the total population (Begon et al., 2002). Inference using mathematical models of infectious disease dynamics is not only useful to identify ‘who acquires infection from whom’, but also to hypothesize the behaviours that could be leading to infection.

In accordance with Knowles et al. (2012), our findings show that most of the transmission could occur during early spring previous to breeding season, in which male home range size increases (Randolph, 1977), contact rates between reproductive males are higher compared to other times of the year and territories are established. Moreover, larger territories could be encompassed by infected males compared to uninfected males, as it has been shown in the wood mouse system, where infected males occupied a ~ 1 ha larger home range compared to uninfected males (2.44 ha vs 1.63 ha) (Brown et al., 1994). Thus, it is sensible to assume that sampled grids in our study site constitute a single wood mice population.

Regarding limitations of our study, antibody detection is not the best test for determining herpesvirus infection because maternal antibodies to the virus are inherited from mother to offspring and persist into young adulthood (Knowles et al., 2012). Therefore, we excluded juveniles from our study; however, we acknowledge that using a PCR diagnostic method could refine our WMHV prevalence results. Furthermore, based on previous findings on murine gamma herpesvirus pathogenesis, our model did not assume disease-induced mortality due to infection (Ackermann, 2006; Davison, 2002). Nonetheless, previous work has found some evidence for a negative association between herpesvirus infection and recapture duration in adults, implying that infection may reduce life expectancy (Knowles et al., 2012). It should be noted that the sample size of subadults in the data was relatively small compared to adults: thus, the inferred minimal role of subadults to WMHV transmission needs to be taken into caution. Finally, the duration of acute and latent infections could differ between sexes, in particular the reactivation rate (latent to acute transition), if induced by different stressors (i.e., male competition or female pregnancy). Nonetheless, the observed

effect of sex-bias transmission at the population level is robust enough that it would be unlikely to be overturned by sex-biased reactivation rates at the individual level.

In summary, our study sheds light on the transmission mechanisms of a natural herpesvirus (WMHV) of wild wood mice by suggesting that transmission is density-dependent and mainly male-driven. Most of the virus transmission could therefore occur through scent-marking behaviour, before the breeding season, when males are establishing territories and home range sizes increase. Females play a less important role and could get infected predominantly by contact with scent-marked territories by males and, less likely, by other female conspecifics. Overall, we highlight the value of long-term longitudinal data, coupled with biologically meaningful mechanistic models, to elucidate key aspects of transmission biology, which otherwise would be hard to detect in the wild or the lab.

Author statement

Diana Erazo: Conceptualization, Formal analysis, Writing - original draft, Writing - review & editing.

Amy B. Pedersen: Data curation, Funding acquisition, Writing - original draft, Writing - review & editing.

Kayleigh Gallagher: Data curation, Investigation, Writing - original draft, Writing - review & editing.

Andy Fenton: Conceptualization, Formal analysis, Funding acquisition, Writing - original draft, Writing - review & editing.

Authors' contributions

AB collected the field data, DE and AF designed the model, DE parameterized the model and drafted the manuscript, and DE, AF and KG analysed the results. All authors contributed to revisions.

Funding

The work was funded by NERC Grants NE/G007349/1 and NE/G006830/1, NE/I024038/1, NE/I026367/1 and NE/R011397/1, awarded to AF and ABP. KG was funded through the NERC ACCE Doctoral Training Partnership. ABP was funded by a Wellcome Trust Strategic Grant for the Centre for Immunity Infection and Evolution (095831) and a University of Edinburgh Chancellors Fellowship.

Declaration of Competing Interest

The authors declare that they have no known competing financial interests or personal relationships that could have appeared to influence the work reported in this paper.

Acknowledgements

We would like to thank those involved in the fieldwork that generated the data used in this study, and the landowners for permission to carry out the work on their land.

Appendix A. Supplementary data

Supplementary material related to this article can be found, in the online version, at doi:<https://doi.org/10.1016/j.epidem.2021.100451>.

References

Abbott, K.D., Ksiazek, T.G., Mills, J.N., 1999. Long-term hantavirus persistence in rodent populations in central Arizona. *Emerg. Infect. Dis.* 5, 102. <https://doi.org/10.3201/eid0501.990112>.
Ackermann, M., 2006. Pathogenesis of gammaherpesvirus infections. *Vet. Microbiol.* <https://doi.org/10.1016/j.vetmic.2005.11.008>.

Anderson, R., May, R.M., 1991. *Infectious Diseases of Humans: Dynamics and Control*. Oxford university press, Oxford, UK.
Antonovics, J., 2017. Transmission dynamics: critical questions and challenges. *Philos. Trans. R. Soc. B Biol. Sci.* 372, 20160087. <https://doi.org/10.1098/rstb.2016.0087>.
Baguelin, M., Medley, G.F., Nightingale, E.S., O'Reilly, K.M., Rees, E.M., Waterlow, N.R., Wagner, M., 2020. Tooling-up for infectious disease transmission modelling. *Epidemics* 32 (100395). <https://doi.org/10.1016/j.epidem.2020.100395>.
Becker, A.D., Grantz, K.H., Hegde, S.T., Bérubé, S., Cummings, D.A.T., Wesolowski, A., 2021. Development and dissemination of infectious disease dynamic transmission models during the COVID-19 pandemic: what can we learn from other pathogens and how can we move forward? *Lancet Digit. Heal.* 3 (1), e41–e50. [https://doi.org/10.1016/S2589-7500\(20\)30268-5](https://doi.org/10.1016/S2589-7500(20)30268-5).
Begon, M., Bennett, M., Bowers, R.G., French, N.P., Hazel, S.M., Turner, J., 2002. A clarification of transmission terms in host-microparasite models: numbers, densities and areas. *Epidemiol. Infect.* 129, 147–153. <https://doi.org/10.1017/S0950268802007148>.
Booth, W., Montgomery, W.L., Prodöhl, P.A., 2007. Polyandry by wood mice in natural populations. *J. Zool.* 273, 176–182. <https://doi.org/10.1111/j.1469-7998.2007.00312.x>.
Botten, J., Mirowsky, K., Ye, C., Gottlieb, K., Saavedra, M., Ponce, L., Hjelle, B., 2002. Shedding and intracage transmission of Sin Nombre Hantavirus in the deer mouse (*Peromyscus maniculatus*) model. *J. Virol.* 76, 7587–7594. <https://doi.org/10.1128/jvi.76.15.7587-7594.2002>.
Brown, E.D., Macdonald, D.W., Tewand, T.E., Todd, I.A., 1994. Apodemus sylvaticus infected with Heligmosomoides polygyrus (Nematoda) in an arable ecosystem: epidemiology and effects of infection on the movements of male mice. *J. Zool.* 234 (4), 623–640. <https://doi.org/10.1111/j.1469-7998.1994.tb04869.x>.
Camacho, A., Funk, S., 2019. fitR Tool Box for Fitting Dynamic Infectious Disease Models to Time Series.
Carslake, D., Bennett, M., Hazel, S., Telfer, S., Begon, M., 2006. Inference of cowpox virus transmission rates between wild rodent host classes using space-time interaction. *Proc. R. Soc. B Biol. Sci.* 273, 775–782. <https://doi.org/10.1098/rspb.2005.3400>.
Cauchemez, S., Boëlle, P.Y., Donnelly, C.A., Ferguson, N.M., Thomas, G., Leung, G.M., Hedley, A.J., Anderson, R.M., Valleron, A.J., 2006. Real-time estimates in early detection of SARS. *Emerg. Infect. Dis.* 12 (1), 110. <https://doi.org/10.3201/eid1201.050593>.
Davison, A.J., 2002. Evolution of the herpesviruses. *Vet. Microbiol.* 86, 69–88. [https://doi.org/10.1016/S0378-1135\(01\)00492-8](https://doi.org/10.1016/S0378-1135(01)00492-8).
Diekmann, O., Heesterbeek, J.A.P., Roberts, M.G., 2010. The construction of next-generation matrices for compartmental epidemic models. *J. R. Soc. Interface* 7, 873–885. <https://doi.org/10.1098/rsif.2009.0386>.
Donnelly, C.A., Ferguson, N.M., Ghani, A.C., Anderson, R.M., 2003. Extending backcalculation to analyse BSE data. *Stat. Methods Med. Res.* 12 (3), 177–190. <https://doi.org/10.1191/0962280203sm337ra>.
Fenton, A., Streicker, D.G., Petchey, O.L., Pedersen, A.B., 2015. Are all hosts created equal? Partitioning host species contributions to parasite persistence in multihost communities. *Am. Nat.* 186, 610–622. <https://doi.org/10.1086/683173>.
Ferrari, N., Cattadori, I.M., Nespereira, J., Rizzoli, A., Hudson, P.J., 2004. The role of host sex in parasite dynamics: field experiments on the yellow-necked mouse *Apodemus flavicollis*. *Ecol. Lett.* 7, 88–94. <https://doi.org/10.1046/j.1461-0248.2003.00552.x>.
François, S., Vidick, S., Sarlet, M., Michaux, J., Koteja, P., Desmecht, D., Stevenson, P.G., Vanderplassen, A., Gillet, L., 2010. Comparative study of murid gammaherpesvirus 4 infection in mice and in a natural host, bank voles. *J. Gen. Virol.* 91 (10), 2553–2563. <https://doi.org/10.1099/vir.0.023481-0>.
Funk, S., King, A.A., 2020. Choices and trade-offs in inference with infectious disease models. *Epidemics* 30 (100383). <https://doi.org/10.1016/j.epidem.2019.100383>.
Hazel, S.M., Bennett, M., Chantrey, J., Bown, K., Cavanagh, R., Jones, T.R., Baxby, D., Begon, M., 2000. A longitudinal study of an endemic disease in its wildlife reservoir: cowpox and wild rodents. *Epidemiol. Infect.* 124, 551–562. <https://doi.org/10.1017/S0950268899003799>.
Hricová, M., Mistríková, J., 2008. Ecological characterization of murine gammaherpesvirus 68 and its epidemiological implications. *Biologia (Bratisl.)* 63, 753–755. <https://doi.org/10.2478/s11756-008-0122-z>.
Keesing, F., Holt, R.D., Ostfeld, R.S., 2006. Effects of species diversity on disease risk. *Ecol. Lett.* 9, 485–498. <https://doi.org/10.1111/j.1461-0248.2006.00885.x>.
Klein, S.L., 2000. Hormones and mating system affect sex and species differences in immune function among vertebrates. *Behav. Processes* 51, 149–166. [https://doi.org/10.1016/S0376-6357\(00\)00125-X](https://doi.org/10.1016/S0376-6357(00)00125-X).
Klein, S.L., 2004. Hormonal and immunological mechanisms mediating sex differences in parasite infection. *Parasite Immunol.* 26, 247–264. <https://doi.org/10.1111/j.0141-9838.2004.00710.x>.
Knowles, S.C.L., Fenton, A., Pedersen, A.B., 2012. Epidemiology and fitness effects of wood mouse herpesvirus in a natural host population. *J. Gen. Virol.* 93, 2447–2456. <https://doi.org/10.1099/vir.0.044826-0>.
Lello, J., Fenton, A., 2017. Lost in transmission...? *Philos. Trans. R. Soc. B Biol. Sci.*, 20160082. <https://doi.org/10.1098/rstb.2016.0082>.
Lembo, T., Hampson, K., Haydon, D.T., Craft, M., Dobson, A., Dushoff, J., Ernest, E., Hoare, R., Kaare, M., Mlengeya, T., Mentzel, C., Cleaveland, S., 2008. Exploring reservoir dynamics: a case study of rabies in the Serengeti ecosystem. *J. Appl. Ecol.* 45, 1246–1257. <https://doi.org/10.1111/j.1365-2664.2008.01468.x>.
May, R.M., Anderson, R.M., 1987. Transmission dynamics of HIV infection. *Nature* 326, 137–142. <https://doi.org/10.1038/326137a0>.
McCurdy, D.G., Shuttler, D., Mullie, A., Forbes, M.R., 1998. Sex-biased parasitism of avian hosts: relations to blood parasite taxon and mating system. *Oikos* 303–312. <https://doi.org/10.2307/3546970>.

- Milho, R., Smith, C.M., Marques, S., Alenquer, M., May, J.S., Gillet, L., Gaspar, M., Efstathiou, S., Simas, J.P., Stevenson, P.G., 2009. In vivo imaging of murid herpesvirus-4 infection. *J. Gen. Virol.* 90, 21. <https://doi.org/10.1099/vir.0.006569-0>.
- Moore, S.L., Wilson, K., 2002. Parasites as a viability cost of sexual selection in natural populations of mammals. *Science* (80-) 297 (5589), 2015–2018. <https://doi.org/10.1126/science.1074196>.
- Nash, A.A., Sunil-Chandra, N.P., 1994. Interactions of the murine gammaherpesvirus with the immune system. *Curr. Opin. Immunol.* 6, 560–563. [https://doi.org/10.1016/0952-7915\(94\)90141-4](https://doi.org/10.1016/0952-7915(94)90141-4).
- Nash, A.A., Dutia, B.M., Stewart, J.P., Davison, A.J., 2001a. Natural history of murine γ -herpesvirus infection. *Philos. Trans. R. Soc. B Biol. Sci.* 356, 569–579. <https://doi.org/10.1098/rstb.2000.0779>.
- Nash, A.A., Dutia, B.M., Stewart, J.P., Davison, A.J., 2001b. Natural history of murine γ -herpesvirus infection. *Philos. Trans. R. Soc. B Biol. Sci.* 356 (1408), 569–579. <https://doi.org/10.1098/rstb.2000.0779>.
- Pedro Simas, J., Efstathiou, S., 1998. Murine gammaherpesvirus 68: a model for the study of gammaherpesvirus pathogenesis. *Trends Microbiol.* 6, 276–282. [https://doi.org/10.1016/S0966-842X\(98\)01306-7](https://doi.org/10.1016/S0966-842X(98)01306-7).
- Perkins, S.E., Cattadori, I.M., Tagliapietra, V., Rizzoli, A.P., Hudson, P.J., 2003. Empirical evidence for key hosts in persistence of a tick-borne disease. *Int. J. Parasitol.* 33 (9), 909–917. [https://doi.org/10.1016/S0020-7519\(03\)00128-0](https://doi.org/10.1016/S0020-7519(03)00128-0).
- Plummer, M., Best, N., Cowles, K., Vines, K., 2006. CODA: Convergence Diagnosis and Output Analysis for MCMC.
- R Development Core Team, 2016. R: A Language and Environment for Statistical Computing. R Found. Stat. Comput., Vienna Austria <https://doi.org/10.1038/sj.hdy.6800737>, 0, {ISBN} 3-900051-07-0.
- Randolph, S.E., 1977. Changing spatial relationships in a population of *Apodemus sylvaticus* with the onset of breeding. *J. Anim. Ecol.* 653–676. <https://doi.org/10.2307/3836>.
- Saino, N., Canova, L., Fasola, M., Martinelli, R., 2000. Reproduction and population density affect humoral immunity in bank voles under field experimental conditions. *Oecologia* 124, 358–366. <https://doi.org/10.1007/s004420000395>.
- Schalk, G., Forbes, M.R., 1997. Male biases in parasitism of mammals: effects of study type, host age, and parasite taxon. *Oikos* 67–74. <https://doi.org/10.2307/3545801>.
- Streicker, D.G., Fenton, A., Pedersen, A.B., 2013. Differential sources of host species heterogeneity influence the transmission and control of multihost parasites. *Ecol. Lett.* 16, 975–984. <https://doi.org/10.1111/ele.12122>.
- Sunil-Chandra, N.P., Efstathiou, S., Arno, J., Nash, A.A., 1992. Virological and pathological features of mice infected with murine gammaherpesvirus 68. *J. Gen. Virol.* 73, 2347–2356. <https://doi.org/10.1099/0022-1317-73-9-2347>.
- Telfer, S., Bennett, M., Carslake, D., Helyar, S., Begon, M., 2007. The dynamics of Murid gammaherpesvirus 4 within wild, sympatric populations of bank voles and wood mice. *J. Wildl. Dis.* 43, 32–39. <https://doi.org/10.7589/0090-3558-43.1.32>.
- Thomas, S.A., Wolff, J.O., 2002. Scent marking in voles: a reassessment of over marking, counter marking, and self-advertisement. *Ethology* 108, 51–62. <https://doi.org/10.1046/j.1439-0310.2002.00753.x>.
- Thrall, P.H., Antonovics, J., Hall, D.W., 1993. Host and pathogen coexistence in sexually transmitted and vector-borne diseases characterized by frequency-dependent disease transmission. *Am. Nat.* 142, 543–552. <https://doi.org/10.1086/285554>.
- Thrall, P.H., Antonovics, J., Dobson, A.P., 2000. Sexually transmitted diseases in polygynous mating systems: prevalence and impact on reproductive success. *Proc. R. Soc. B Biol. Sci.* 267, 1555–1563. <https://doi.org/10.1098/rspb.2000.1178>.
- Wald, A., Corey, L., 2007. HSV: persistence in the population: epidemiology, transmission. *Human Herpesviruses: Biology, Therapy, and Immunoprophylaxis*. <https://doi.org/10.1017/CBO9780511545313.037>.
- Webster, J.P., Borlase, A., Rudge, J.W., 2017. Who acquires infection from whom and how? Disentangling multi-host and multimode transmission dynamics in the ‘elimination’ era. *Philos. Trans. R. Soc. B Biol. Sci.* 372, 20160091 <https://doi.org/10.1098/rstb.2016.0091>.
- Wolff, J., 2007. Social biology of rodents. *Integr. Zool.* 2, 193–204. <https://doi.org/10.1111/j.1749-4877.2007.00062.x>.