



THE UNIVERSITY *of* EDINBURGH

Edinburgh Research Explorer

Planning Integrated Energy Systems in Local Communities Under Uncertainty

Citation for published version:

Sun, W, Yang, J & Harrison, G 2019, 'Planning Integrated Energy Systems in Local Communities Under Uncertainty', Paper presented at 25th International Conference on Electricity Distribution, Madrid, Spain, 3/06/19 - 6/06/19. <<https://www.cired-repository.org/handle/20.500.12455/752>>

Link:

[Link to publication record in Edinburgh Research Explorer](#)

Document Version:

Early version, also known as pre-print

General rights

Copyright for the publications made accessible via the Edinburgh Research Explorer is retained by the author(s) and / or other copyright owners and it is a condition of accessing these publications that users recognise and abide by the legal requirements associated with these rights.

Take down policy

The University of Edinburgh has made every reasonable effort to ensure that Edinburgh Research Explorer content complies with UK legislation. If you believe that the public display of this file breaches copyright please contact openaccess@ed.ac.uk providing details, and we will remove access to the work immediately and investigate your claim.



PLANNING INTEGRATED ENERGY SYSTEMS IN LOCAL COMMUNITIES UNDER UNCERTAINTY

Wei SUN, Jingjie YANG, Gareth HARRISON

*School of Engineering
The University of Edinburgh
Edinburgh, Scotland*

w.sun@ed.ac.uk, jingjie.yang@ed.ac.uk, gareth.harrison@ed.ac.uk

ABSTRACT

This paper develops an optimal planning method for local energy system (LES) based on energy hub model, considering uncertainty quantification with global sensitivity analysis (GSA) towards robust design. First, a deterministic planning optimization is conducted to acquire the basic case of installation decisions for LES. Second, uncertainty analysis was carried out based on deterministic results, with proper distribution of variation for uncertainty parameters introduced and large size sample collected with Monte Carlo method. Finally, GSA is conducted by calculating Sobol Index for each uncertainty sources to carry out quantitative investigation in terms of uncertainty impact on planning results. A case study for the optimal planning of a practical village in Northern Scotland is provided to illustrate the application of the proposed framework.

INTRODUCTION

Traditionally, most energy services are supplied via independent infrastructures to consumers. However, interdependencies of various energy systems have significantly increased in recent years [1-3]. Gas consumption by large balancing power plants has become more volatile with the rapid development of renewables. At the distribution level, a growing number of combined heat and power units (CHP) have been installed [4]. Promising technologies, such as power-to-gas and fuel cells, enables further options for converting energy supplies from one vector to another [5, 6]. Interactions between different energy systems not only imposes complexity but also represents a potential opportunity for system technical, economic and environmental improvements using the flexibilities across vectors. Evaluation for integrated energy systems shows that local energy systems incorporating with multiple distributed generation and storage technologies are expected to be a core form of future energy supply [7].

Conventional planning approaches that study energy systems separately may not be sufficient to coordinate interdependencies. A ‘whole system’ planning approach is essential to capture the synergies and to reduce the risks associated with securing an integrated system. A few recent studies have addressed the challenges of integrating different energy systems. Most of them focused on large

scale systems at the transmission level incorporating gas and electricity network with bulk demand in consideration [8-10]. The energy systems at local level, which will see increasingly complex interactions with micro CHP, heat pumps, electric vehicles, smart meters, etc., are not fully studied yet.

As efforts towards low-carbon energy supply are made, intermittent renewable generation are developing in unprecedented scale since they can significantly improve system environmental performance [11]. In the meantime, with the development of smart devices and advanced communication and control technology, the customer-side is becoming more variable and is bringing uncertainty as well [12-14]. With interactions between different energy sectors in the system, these uncertainties may have accumulated adverse effects for whole system optimal design, where they could bring in the risk of suboptimal planning decisions for the system, resulting in power shortage or energy curtailment and waste in future operation.

To address these problems above, this paper proposes an optimal planning model for local communities considering multiple energy vectors, including electricity, natural gas, and heat. A wide range of energy conversion technologies are modelled, which allows more choices for energy source in planning process. Different forms of storage are also considered to improve flexibility and unlock synergies. The planning model minimizes the total system cost by determining investments on infrastructure options, with constraints including satisfaction of the electricity and heating demand at each time step over the planning horizon. The objective takes into account both capital and operational cost, and carbon emissions budget are considered as well.

The effective design of integrated energy system is subject to uncertainties arising from aspects such as the availability of renewable energy, energy demand, and prices of different fuels. The deterministic planning models overlook these and can lead to suboptimal system configurations that are not robust against future uncertainty. Measuring the impact of uncertainty in system planning is necessary to obtain a robust design against uncertainty. Therefore, the second goal of this paper is to present a novel framework for investigating uncertainty in the context of LES design, which combines planning models and techniques of GSA together.

MODEL FORMULATION

Planning model for LES

This section introduces the long-term planning model for local energy system. A typical LES includes electric, heating, gas systems and the coupling between them, which can be depicted by an energy hub model shown in Fig. 1.

In a typical local community, electrical energy consumption includes lightning, appliances and so on, could be provided by grid power (GP), photovoltaic (PV) generation, wind generation (WG), biomass generation (BG), combined heating and power unit (CHP) or electric energy storage system (EESS). Thermal energy consumption includes space heating, cooling and hot water, and could be met by CHP, gas boiler (GB), solar-thermal (ST) unit, heat pump (HP), electric boiler (EB) or thermal energy storage system (TESS). Energy conversion units, such as HP which plays roles as electrical energy consumption unit and thermal energy provider at the same time, interlink different energy sectors together as a whole system.

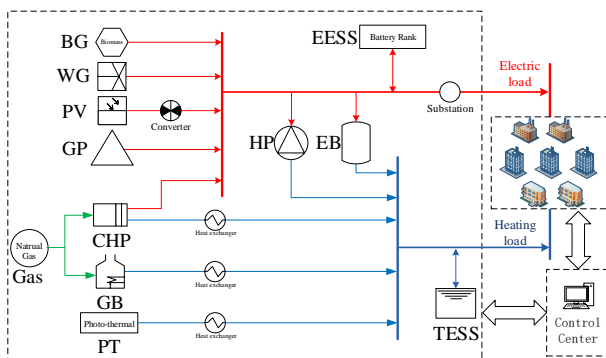

Fig. 1 LES topology based on energy hub model

As is shown, to design a LES for a community, various energy conversion and storage technologies can be chosen to meet the thermal and electrical energy requirements on demand side. The optimization model in this work is to select the proper technologies and to decide their capacity for the specific community, while optimizing for a minimal equivalent annual cost (EAC) of the system composed of investment cost and operation cost. The optimization variables, including both capacity and dispatch decisions, are decided in light of meeting electrical and thermal demand at each simulation step along the entire planning horizon, considering technical, economical, and environmental constraints of the whole system.

The mathematical formulation framework of the planning optimization model for LES is shown in Fig. 2.

The optimization of LES planning is a mixed-integer linear programming (MILP) problem, as the energy hub model linearizes the energy flow relations running throughout the system. The objective function is comprised of operating

cost due to electricity and gas purchase from utility and amortized technology investment cost due to newly instalments. The optimization problem is subject to several constraints, including energy balance constraints for electrical, gas and heating system, operational constraints for all the technologies, which cover power output upper- and lower- limits, storage charging/discharging rate limits, storage energy balance due to charge/discharge flows, and carbon emission constraint of the whole system. The optimization variables include equipment capacities, hourly external energy exchange with utility, and hourly technology utilization within the system. Input parameters include technical parameters such as energy conversion efficiencies and storage charging/discharging efficiencies, economical parameters such as investment cost per capacity unit for each technology and operating expenditure per unit energy consumed, demand profile including electric and heating load, and renewable profile including solar radiation and wind energy throughout the entire planning horizon.

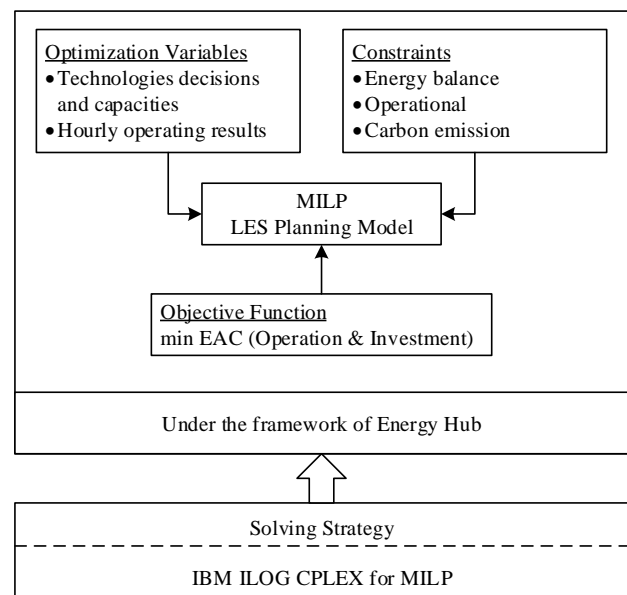

Fig. 2 Mathematical formulation framework of the planning optimization model for LES

Uncertainty measurement with GSA

In order to obtain a robust design against multiple uncertainties of the system, a novel framework for measuring various uncertainty sources in the context of LES planning is presented in this section.

In a LES planning model, uncertainties, which have effects on the planning results, can arise from demand-side in light of electric and heating load profiles, supply-side with respect to renewable energy profiles, and economical parameters such as capital prices and feed-in tariff of energy. These parameters are time series values with the same resolution as simulation step, and the variation distribution is introduced as each value of their yearly schedules is randomly varied by $\pm 10\%$ around its nominal

value. A Monte Carlo method is adopted to generate a sample of size N from each parameter distribution. Then the model can be evaluated N times using the sample to investigate the uncertainty propagation of each parameter according to model outputs.

The GSA technique used in this work is based on the decomposition of the output variance of the model. There are two quantitative sensitivity measures, the first-order Sobol Index S_1 and the total-order Sobol Index S_T , to evaluate the contribution of each input parameter to the output variance [15]. Index S_1 indicates the contribution to the output variance that can be attributed to a given input, while S_T measures the contribution to the output variance of the given input including all variance caused by its interactions with other inputs.

This method allows us to distinguish the most influential input parameters from others, and according to which the robust design for LES can be generated in response to future uncertainty.

CASE STUDY

Case study is carried out on a village in Scotland to evaluate the effectiveness of the proposed method. An illustration of the neighbourhood is shown in Fig. 3. The village consists of around 100 residential houses and 20 commercial buildings. The energy demands of the district are obtained based on historical data collected from local operator.



Fig. 3 Illustration of a Scotland neighbourhood

The candidate technologies considered in this planning problem include wind, PV, battery storage, heat pump, gas boiler, CHP, P2G unit, and gas storage. The financial characteristics of each technology are shown in Table I.

Table I. Financial characteristics of technology

Technology	NPV of investment (£/kw)	Economic lifetime (year)	Weighted average cost of capital
Wind	1749	15	0.05
PV	1000	15	0.05
Gas boiler	154	15	0.05
CHP	1310	15	0.05
Heat Pump	650	15	0.05
Battery storage	1600	10	0.05
P2G	1000	15	0.05
Gas storage	300	15	0.05

Planning results

The deterministic optimization results are adopted first to serve as the basic case for GSA. Simulation is conducted on an hourly basis for one-year horizon. As shown in Fig. 4, the installation decision for the demonstration consists of wind turbine, PV, heat pump and battery storage. The total cost is 3.8 million pounds in basic case.

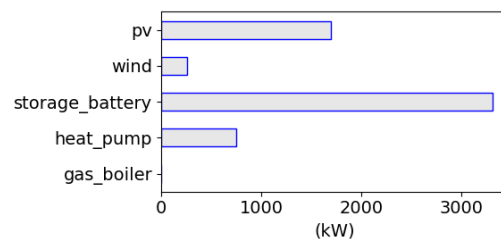

Fig. 4 Installation decision in deterministic case

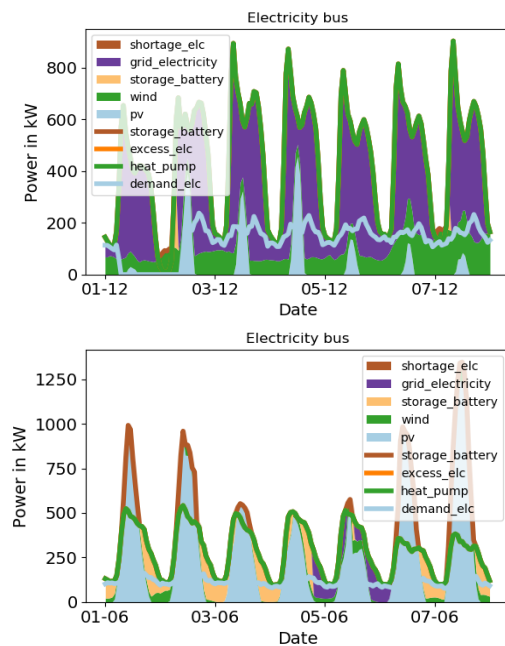

Fig. 5 Typical operational scenarios in winter (top) and summer (bottom)

Two operational scenarios based on this case, the first

week of December and June for winter and summer case respectively, are revealed in Fig. 5. The first five variables in each figure, which are plotted as area graph, indicate source of energy supply; while the rest four, which are plotted as line graph, depict different energy demands. Both the areas and lines are plotted in stacked manner to illustrate that in both scenarios the energy supply matches the demand requirements perfectly.

The electrical and thermal energy consumption and sources over the entire year are depicted in Fig. 6 and Fig. 7.

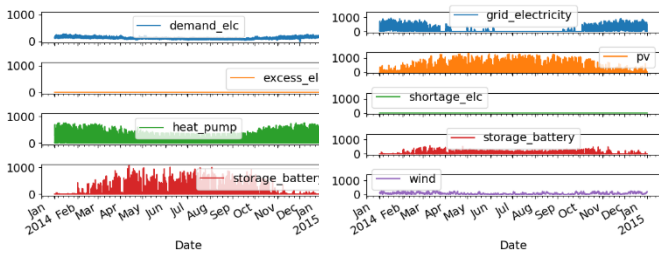

Fig. 6 Electricity consumption (left) and sources (right) in one year

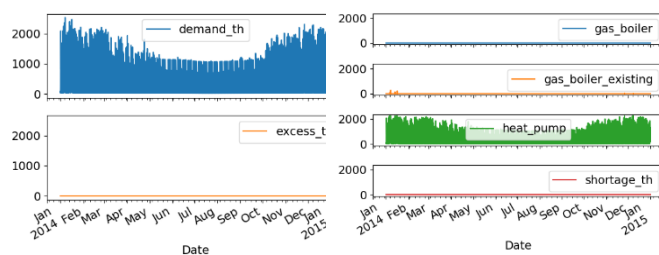

Fig. 7 Heat consumption (left) and sources (right) in one year

From the one-year operational results, we can see that with input parameters fixed in their nominal value, the deterministic model can obtain an optimal design with which the system will have no energy shortage or excess energy produced.

As was mentioned in the second section, four uncertainty sources, including variable demand profiles and renewable energy profiles, are calculated by adding random variances within $\pm 10\%$ around their nominal value throughout the time series. A test sample is obtained by a Monte Carlo method, according to which 2000 runs of LES planning optimization are executed.

Uncertainty analysis

Fig. 8 shows the variation of the planning objective, the equivalent annual cost (EAC) value, in terms of probability density function (PDF) and cumulative distribution function (CDF).

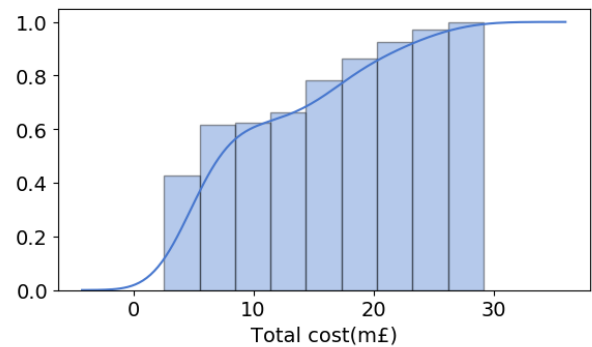

Fig. 8 PDF and CDF of the ECA value

It is evident that due to uncertainties in the system, the total cost can vary between 2.5 to 28 million pounds around nominal value of 3.8 million pounds in basic case. It can be deduced from the CDF curve that there is over 88% probability that the total cost will be larger than the deterministic result.

Fig. 9 shows the variation of the optimal design of technologies for each of the Monte Carlo runs. CHP, P2G unit, and gas storage are not shown in the figure because none of them is chosen during the 2000 runs.

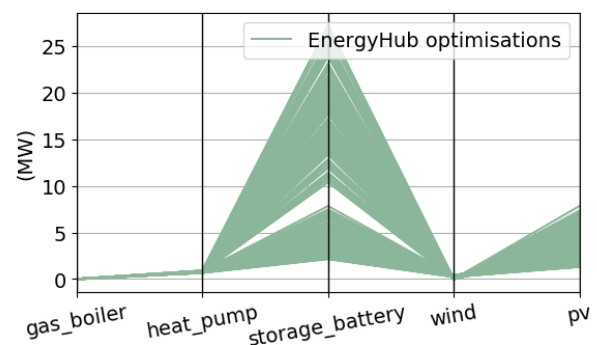

Fig. 9 Results of 2000 Monte Carlo runs for Energy hub model

As can be seen, gas boiler is seldom chosen in the optimal design, and the capacity of it is extremely small. Heat pump is always chosen and the capacity is mostly fixed around 1MW as what is installed in the basic case. Although the chosen capacity of heat pump is relatively small, it has a very high energy conversion efficiency so that almost all of the heat load in the whole system can be supported by heat pump. Battery storage is always chosen in planning decisions as it can flexibly shift energy consumption to adapt to energy prices variation in the real time, but the capacity of which varies considerably, which means the installation of storage capacity will be highly influenced by uncertainty.

To evaluate the influence of the four important time-series uncertainty sources, Sobol Indexes are obtained to interpret quantitatively (Fig. 10). As is obvious, the most

important uncertainty parameter to influence the planning model is wind, as can be seen below. We can also tell that the model is mainly dominated by first-order Sobol Index and higher order effects only have a little influence on model output.

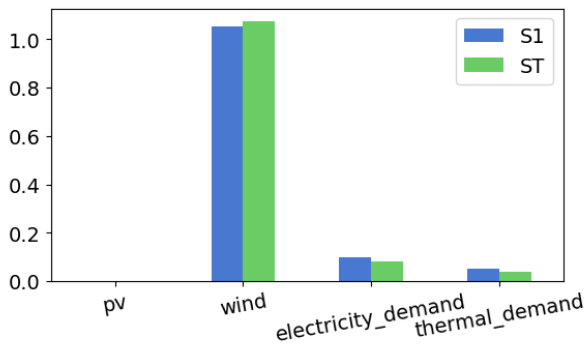

Fig. 10 S_1 and S_T of the four important uncertainty sources

CONCLUSION

In this paper, a planning method for LES is proposed to minimize the total system cost by determining investments on infrastructure options and to guarantee robustness of planning decisions by measuring the impact of uncertainty in terms of local community optimal design.

Initially, a deterministic planning model for local community based on energy hub model is developed, according to which a yearly operational planning decision is obtained. Subsequently, random variation is introduced to some important uncertainty parameters in the model, and samples are adopted with Monte Carlo method to perform uncertainty analysis. Finally, GSA is used to evaluate the impact of different uncertainty sources quantitatively to acquire a robust design for LES.

In the future, the planning framework will be extended to multi-scale energy system robust planning, which will address uncertainties in systems at different levels that are operated independently but interact with each other, to better simulate the realisation. In addition, this work's contribution will be applied in stochastic programming for multi-objective system operational planning, to seek for an optimal and robust design under several goals.

ACKNOWLEDGEMENT

The work was sponsored by the University of Edinburgh and the EPSRC National Centre for Energy Systems Integration (grant EP/P001173/1)

REFERENCES

[1] P. Mancarella, G. Andersson, J. A. Peças-Lopes and K. R. W. Bell, 2016, "Modelling of integrated multi-energy systems: Drivers, requirements, and opportunities", *2016 Power Systems Computation*

Conference. Genoa, 1-22.

[2] X. Xu, X. Jin, H. Jia, 2015, "Hierarchical management for integrated community energy systems", *Applied Energy*. vol. 160, 231-243.

[3] W. Lin, X. Jin, Y. Mu, H. Jia, X. Xu, X. Yu, B. Zhao, 2018, "A two-stage multi-objective scheduling method for integrated community energy system", *Applied Energy*. vol. 216, 428-441.

[4] Y. Jiang, J. Xu, Y. Sun, C. Wei, J. Wang, S. Liao, D. Ke, X. Li, J. Yang, X. Peng, 2018, "Coordinated operation of gas-electricity integrated distribution system with multi-CCHP and distributed renewable energy sources", *Applied Energy*. vol. 211, 237-248.

[5] Meysam Qadrdan, Hossein Ameli, Goran Strbac, Nicholas Jenkins, 2017, "Efficacy of options to address balancing challenges: Integrated gas and electricity perspectives", *Applied Energy*. vol. 190, 181-190.

[6] M. Qadrdan, M. Abeysekera, M. Chaudry, J. Wu, N. Jenkins, 2015, "Role of power-to-gas in an integrated gas and electricity system in Great Britain", *International Journal of Hydrogen Energy*. vol. 40, 5763-5775.

[7] P. Mancarella, 2014, "MES (multi-energy systems): An overview of concepts and evaluation models", *Energy*. vol. 65, 1-17.

[8] M. Chaudry, N. Jenkins, G. Strbac, 2008, "Multi-time period combined gas and electricity network optimisation", *Electric Power Systems Research*. vol. 78, 1265-1279.

[9] H. Cui, F. Li, Q. Hu, L. Bai, X. Fang, 2016, "Day-ahead coordinated operation of utility-scale electricity and natural gas networks considering demand response based virtual power plants", *Applied Energy*. vol. 176, 183-195.

[10] C. Liu, M. Shahidehpour, Y. Fu and Z. Li, 2009, "Security-Constrained Unit Commitment With Natural Gas Transmission Constraints", *IEEE Transactions on Power Systems*. vol. 24, 1523-1536.

[11] M. Qadrdan, M. Chaudry, J. Wu, et al, 2010, "Impact of a large penetration of wind generation on the GB gas network", *Energy Policy*. Vol. 38, 5684-5695.

[12] F. Boshell and O. P. Veloza, 2008, "Review of developed demand side management programs including different concepts and their results", *Proc. IEEE PES Transmiss. Distrib. Conf. Expo. Latin Amer.*, Bogota, Colombia, 1-7.

[13] M. Pedrasa, T. Spooner, and I. MacGill, 2009, "Scheduling of demand side resources using binary particle swarm optimization", *IEEE Transactions on Power Systems*. vol. 24, 1173-1181.

[14] M. Razmara, G. R. Bharati, M. Shahbakhti, et al. 2018, "Bilevel Optimization Framework for Smart Building-to-Grid Systems", *IEEE Transactions on Smart Grid*. vol. 9, 582-593.

[15] Eikos, 2012, *Eikos Sensitivity Analysis Toolbox*, Facilia AB, Bromma, Sweden, 68-75.