

Wrappings of power: a woman's burial in cattle hide at Langwell Farm, Strath Oykel

Olivia Lelong*

with contributions by Iraia Arabaolaza, Thomas Booth, Jane Evans, Richard P Evershed, Susanna Harris, Hege Hollund, B J Keely, Angela Lamb, M D Pickering, A P Pinder, Susan Ramsay, Penelope Walton Rogers, Lucija Šoberl, Clare Wilson and Lyn Wilson

ABSTRACT

A well-preserved burial, discovered during peat clearing on Langwell Farm in Strath Oykel, Easter Ross, consisted of a stone cist that held the skeleton of a woman who had died in 2200–1960 cal BC. Although the cist contents were disturbed and partly removed before archaeological investigation took place, the burial rite can be interpreted to some extent. The woman, who died in her late 20s, had been wrapped in brown cattle hide, and wooden and woven objects were placed with her body. Periodic waterlogging created conditions that allowed the rare, partial preservation of the organic materials. Analysis of bone histology indicated that decay of the human remains had been arrested, either by deliberate mummification or by waterlogging. The cist had been set into a low knoll on the valley floor and it may have been covered with a low cairn or barrow. This spot had been the site of a fire several hundred years earlier, and it may have been a node on a cross-country route linking east and west coasts in the Early Bronze Age. The use of animal hide suggests the creation and use of particular identities, linking the dead to ancestors and to powerful spiritual properties attributed to the natural world. The work was carried out for Historic Scotland under the Human Remains Call-off Contract.

INTRODUCTION

In February 2009, a remarkable burial in a short cist was discovered on Langwell Farm, Strath Oykel in Easter Ross (illus 1). While supervising the clearing of peat for use in flood defences, the landowner, Mr Jonathan Hampton, observed the mechanical excavator disturb and crack a large slab and saw soil slip into the void revealed beneath it. Looking into the void, he saw what appeared to be a skeleton covered with white powdery material, with what he later described as woven material resembling a basket around the head and in the lower leg region. Three photographs taken immediately after its

discovery by Mr John White, who was operating the mechanical excavator, are shown in illus 2. Mr Hampton informed Historic Scotland and the Northern Constabulary. Local police then visited the site and, on the orders of the procurator fiscal and in the absence of Mr Hampton, partially emptied the cist of its contents.

A team of archaeologists from the former Glasgow University Archaeological Research Division subsequently investigated the cist under the direction of the principal author. This involved the salvage excavation of the remaining contents (illus 3) and the investigation of the cist's construction, as well as an area 5m to the south (illus 1, Area B), where the

* Northlight Heritage, 64 Osborne Street, Glasgow G1 5QT

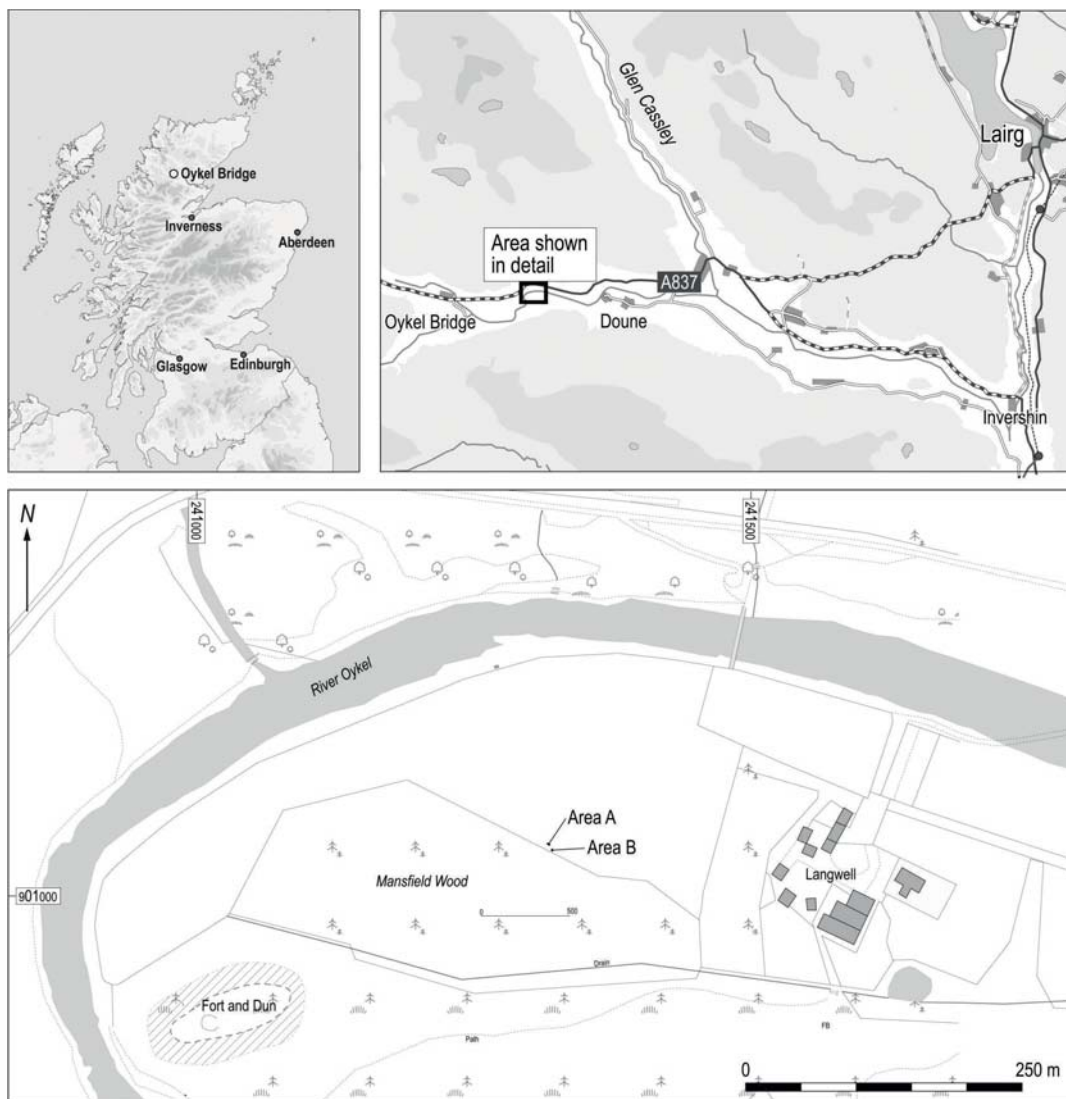

ILLUS 1 Location plan

mechanical excavator had dislodged some large slabs. The work was carried out over six days in freezing, snowy conditions. The bones that the police had removed from the cist were retrieved by the principal author from Dornoch police station on 20 February 2009, where they had been refrigerated since their removal. On receipt, the bones were in clear plastic bags and no organic material, other than fibres

adhering to their surfaces, was found to accompany them.

A second phase of fieldwork took place in August 2009, when a team of archaeologists and a palaeobotanist from the former Glasgow University Archaeological Research Division conducted an environmental survey of the area under the direction of Alastair Becket, with the assistance of members of the North of Scotland

Archaeological Society. This involved an auger survey to test for the presence of additional cists in the surrounding area and characterise the sub-surface topography of the site, as well as profiling and sampling of peat deposits. The auger and visual surveys of the area recorded a concentration of river cobbles immediately

around the cist. These are interpreted as the remains of a robbed cairn or barrow. The locations of the auger points and peat profiling test pits are shown in illus 4.

Historic Scotland funded and monitored both phases of fieldwork and the programme of post-excavation analysis.



ILLUS 2 The burial as first discovered: with detailed views of the head (top right) and flexed lower leg (bottom), both associated with what appear to be woven materials. Photos taken from the south-east by John White



ILLUS 3 The burial as first observed by the excavation team, looking down into the cist from the south-east

SITE LOCATION

The burial was found in a level field that borders the south bank of the River Oykel, immediately north of a modern conifer plantation named Mansfield Wood, at NGR NC 4130 0104 and at 20m above OD (illus 1). The excavated features occupy a very slight ridge, approximately 18m east/west by 10m in width. To the south of the forestry plantation, the ground rises steeply by 20m to 30m to several knolls. The solid geology consists of unknown igneous bedrock of the Morar group, of Neoproterozoic age, while the superficial geology consists of alluvial sand and gravel.

ARCHAEOLOGICAL CONTEXT

The presence of well-established communities in Strath Oykel and neighbouring valleys during earlier prehistory is well attested; concentrations of Neolithic chambered cairns as well as later, Bronze Age ceremonial monuments and settlement remains mark out areas of the landscape that were the focus for communities over several millennia. These valleys form natural corridors through the northern Scottish land mass, which may have been used as routeways in prehistory. Strath Oykel, for example, links the east and west coasts of northern Scotland and also joins the valley of the River Shin that links Loch Shin and

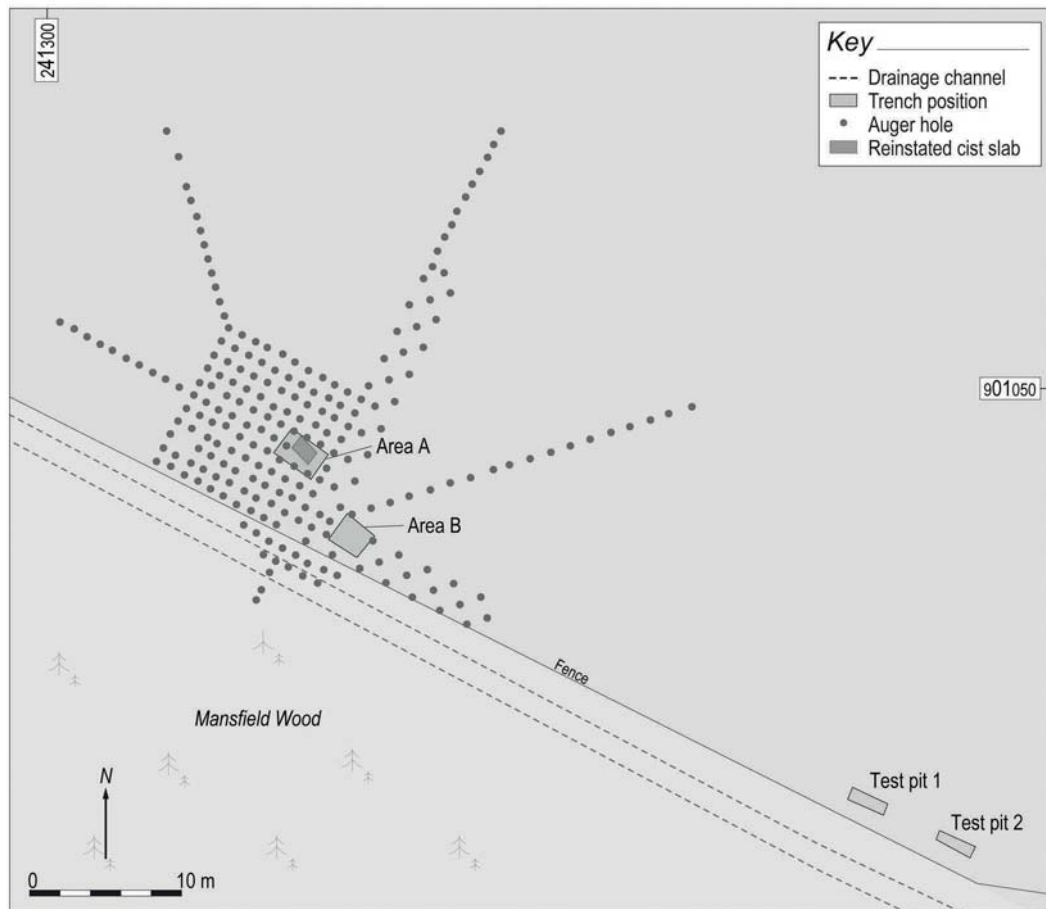

ILLUS 4 The locations of auger points and test pits through the peat

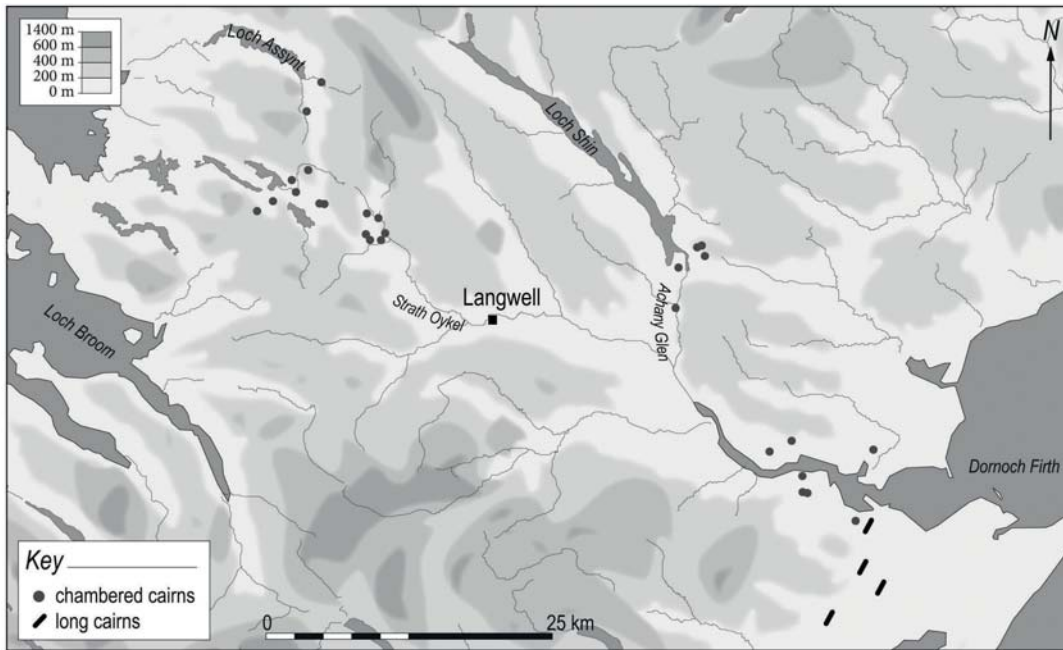

ILLUS 5 Chambered and long cairns in and around Strath Oykel

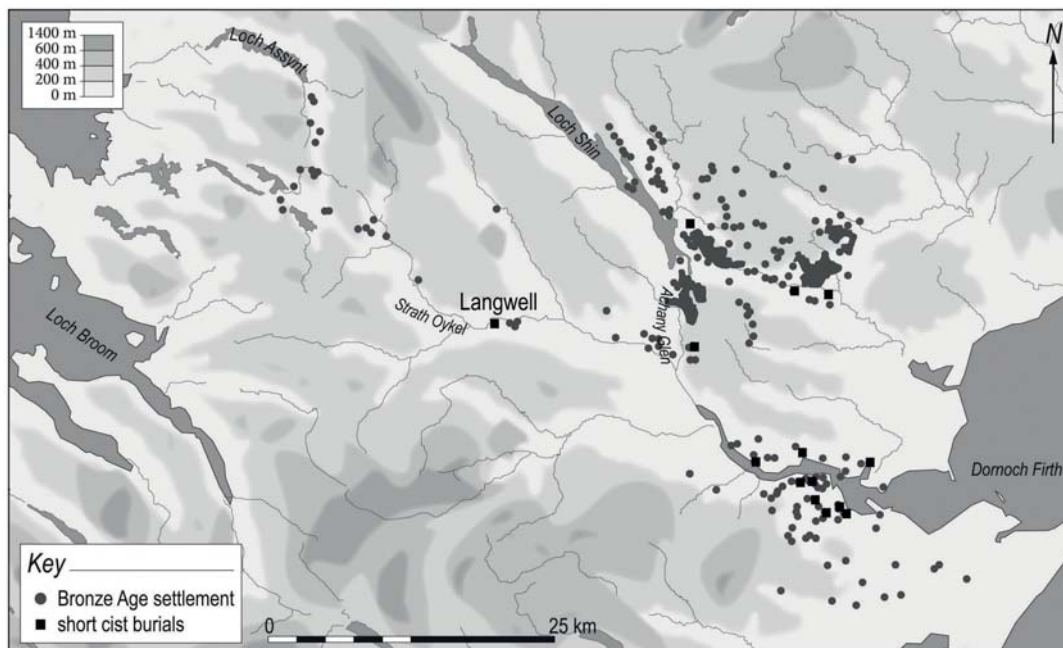

ILLUS 6 Bronze Age settlement and burial remains in and around Strath Oykel

the Kyle of Sutherland. A striking concentration of Neolithic chambered cairns occurs at each end of Strath Oykel, with 17 known around its western end and eight at its east (illus 5). There is also a notable cluster of chambered cairns along the course of the River Shin and around the south end of Loch Shin.

Archaeological remains of settlement and burial from the second millennium BC cluster heavily in the valley of the River Shin, to the east of Loch Shin and around the Dornoch Firth, with a more diffuse trickle known along Strath Oykel and farther west (illus 6) – although this may be due to fieldwork biases. An extensive programme of work was carried out in the 1980s in advance of road works near Lairg (McCullagh & Tipping 1998), which lies about 18km to the ENE of Langwell via river valleys. This found abundant evidence for settled farming by 2200–2000 BC, with cairns and enclosures containing cremation burials associated with Beakers and Food Vessels. This period also saw farming and land enclosure of unprecedented intensity, which resulted eventually in soil erosion (ibid: 205–7).

In the immediate vicinity of the cist on Langwell Farm are several known archaeological sites of prehistoric date. These include a group of three hut circles associated with a field system (NMRS NC40SW 6), another nearby hut circle and clearance heaps (NMRS NC40SW 5) and a probable burial cairn (NMRS NC40SW 7), all on the opposite side of the river valley, about a kilometre to the east. On a knoll a few hundred metres to the WSW of the cist is the vitrified dun and earlier fort of Torr a' Chorcain, which was partially excavated in the 1970s. The timber-laced wall of the dun had been vitrified, and timber felled for its latest roof dated to the 3rd century BC (NMRS NC40SW 3; Nisbet 1995).

By the end of the first millennium AD, Strath Oykel formed the southern boundary of *Sudrland* – the southern part of what was then the Norse province and later earldom of Caithness – and Norse place-names highlight its importance as a cross-country route during this period. The early 19th century saw the transformation of Strath Oykel's social and economic landscape from one of small, nucleated joint tenant farms to one cleared of its tenants, with large tracts of

land devoted to sheep grazing and recreational shooting, and managed from newly built lodges and farmsteads like those at Langwell. The first edition Ordnance Survey map of the area, published in 1881, depicts the shooting lodge, kennels and other outbuildings at Langwell surrounded by large enclosed fields along the riverside. The field containing the cist is depicted as rough pasture. It has been improved and ploughed over the last approximately 50 years (Mr Jonathan Hampton pers comm).

METHODOLOGY

February 2009 fieldwork

Upon arrival at the site, the excavation team removed the tarpaulin that covered the cist and recorded its contents by photograph and measured sketch. A trench measuring 3m WNW/ESE by 2m was laid out over the cist, and the surrounding area was cleaned to remove remnants of the peat and reveal the cut for the cist. The interior of the cist was cleaned to remove loose, intrusive deposits that had fallen inside during and after its discovery; this revealed several bones and concentrations of organic material lying in disturbed deposits. To facilitate recording and sampling, a 20cm grid was laid out over the cist floor and the contents were recorded by detailed photography and measured drawing.

Just as excavation was about to commence, the upright slab forming the cist's north side fell inward. This slab was less securely set than the others – the north-east corner lacked the pinning stones that wedged the other corners tightly in place – and it had been destabilised by the movement of machine and feet around it. Fortunately, it fell against the southern slab at an angle over the interior, so it did not touch the contents. The slab was lifted clear of the cist with the aid of Mr and Mrs Hampton's tractor, and excavation proceeded.

The contents of the cist were excavated in two stages. The first involved the removal of the loose, disturbed deposits that were exposed after initial cleaning; they were 100% sampled according to context and grid square, and the positions of all

human remains and organic materials lifted at this stage were recorded. This process revealed further, *in situ* human remains and organic materials. After recording by photograph and measured drawing, they were lifted and the sediment around and beneath them was excavated and 100% sampled according to body area. The underlying deposits were then excavated and sampled, also according to body area. All materials removed from the cist, including the bones recovered by the police, were subsequently stored in cold conditions. Excavation personnel wore latex gloves at all times during excavation and when handling material from the cist.

The north/south and east/west sections across the cist were investigated and recorded to some extent; however, at the landowners' request, the cist structure was not dismantled. It also proved impossible at this stage to excavate to the edge of the cut on the north (where the side slab had been removed) because the deposits were frozen solid. After recording, the northern slab was reinstated and the interior of the cist was partially backfilled to stabilise the structure.

A trench measuring 2.2m north-west/south-east by 1.8m was also opened about 5m to the south of the cist, centred over the spot where two large slabs had been removed by the mechanical excavator (Area B). Removal of the overlying peat revealed an arcing, stone-built feature. After recording, a slot trench 0.5m wide was excavated across it and through the surrounding deposits. The archaeology was recorded in plan and section and the trench was backfilled.

August 2009 fieldwork

During the August 2009 fieldwork, the cist was revisited and a small slot was excavated through its exterior on the east to retrieve a bulk sample of the material filling the cut. A sample was also taken of the ground surface sealed beneath the arcing stone feature in Area B, which had been frozen earlier in the year. The underside of the capping slab was examined for any markings, but none were identified.

An area measuring approximately 12m north-west/south-east by 10m was examined by auger survey (illus 4). This centred on the low ridge

the cist occupied, and transects extended from it in five directions to measure the sub-surface slope. The ground was augered at 1m² intervals, recovering a contiguous sample of sediment from the surface down to basal natural. The depth of organic overburden was recorded along with sediment composition and any evidence of buried stones or plough truncation. Where sub-surface stones were encountered, their size and extent were investigated using a thin metal bar prodded into the ground. A planned geophysical survey of the area was not carried out due to logistical problems.

Two test pits were also excavated to the east of the cist, close to the fence line, using a mechanical excavator fitted with a toothless ditching bucket, to provide a profile through surviving peat deposits. In the eastern pit (2), which exposed the deepest peat deposits, one side was cleaned and photographed and three 30cm Kubiena monolith tins were hammered into the exposed peat face, each overlapping by 5cm. The basal tin (3) clipped the sandy natural subsoil. The sediment above the uppermost tin (1) was collected as a separate block, and all of the tins were excavated and wrapped for storage.

EXCAVATION OF THE BURIAL

The contents of the cist

On the floor of the cist, below the disturbed deposits, part of the skeleton survived *in situ*. The positions of these skeletal elements are shown in plan in illus 7, along with those recovered from the overlying deposits. The *in situ* elements indicated that the body had been placed on the left side, with the legs tightly flexed and the arms also flexed to lie across the chest. This corroborates the body position apparent in the pre-disturbance photographs (see illus 2). A radiocarbon date obtained from the right fibular shaft has been calibrated to 2200–1960 cal BC (SUERC-24680) at 95.4% confidence (Oxcal v4.1).

The *in situ* elements, shown in illus 8, included bones from the right upper and lower arm (humerus and radius), several vertebrae and both sides of the pelvis – although the right pelvis

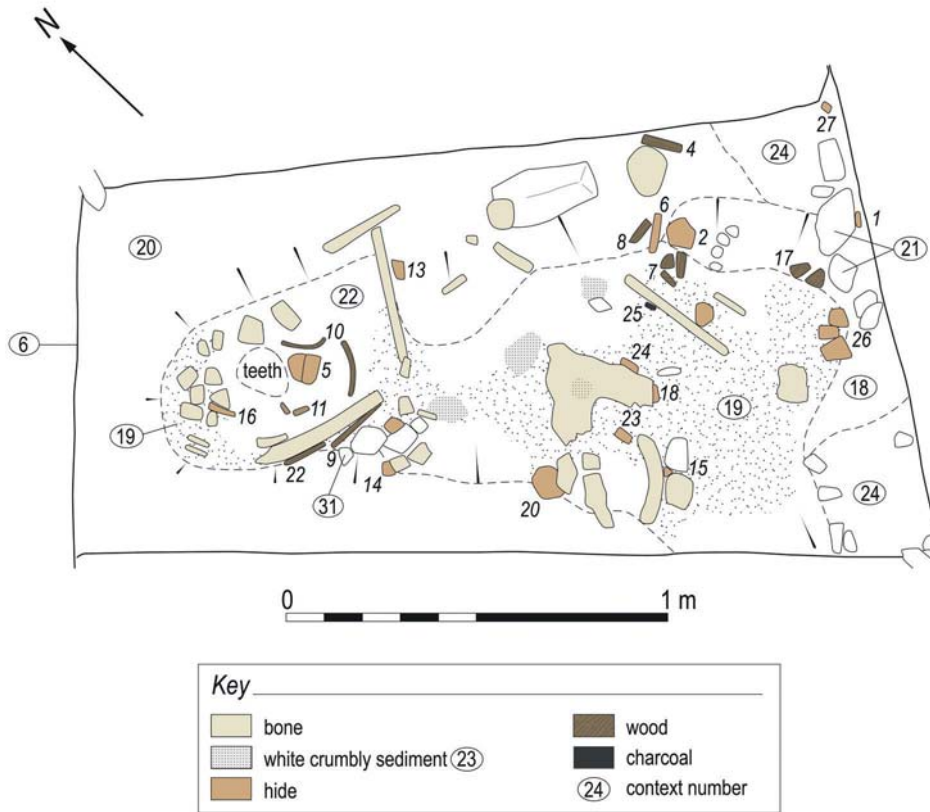

ILLUS 7 Plan of the human remains and organic materials

and the sacrum were highly degraded. The head of the right femur (thigh bone) lay against the right pelvis, but the rest of the femur was absent. Parts of two long bones from the lower leg lay in approximately correct anatomical position, and to the south of these lay a concentration of highly degraded bone, possibly a talus or calcaneus from the foot. Several teeth and soft, black cranial fragments lay near the north-west end of the cist in the position of the head.

These in situ bones lay in greasy, fine black-brown sediment (context 19), the extent of which corresponded to the position of the body. It most likely derived from the decay of the body and associated organic materials. The burial rested on loose brown-orange gravelly sand (context 20), the exposed surface of the alluvial subsoil. Several concentrations of soft, crumbly, creamy-

white sediment (context 23) were found in the thoracic, abdominal and pelvic areas, one lying directly on the left pelvis. Fine fibres were found around both pelvic components, in the lower leg area and in the head area. Fibres were also found on the upper jaw bone (right maxilla), right thigh bone (femur) and both lower legs (tibiae) during later examination of the human remains from the cist, including those removed by the police (see Arabalaza, below). Subsequent analysis established that these were all from a cattle hide that had been wrapped around the body at the time of burial (see Walton Rogers, below). Four small stones (context 31) in a row along the upper right arm and another cluster (context 21) in the feet area may have been placed to hold down the edges of the hide wrapping. A radiocarbon date from the fibres indicates the animal died between



ILLUS 8 The in situ human remains after removal of disturbed deposits, from the north and above

2040–1880 cal BC (SUERC-32348), while two wood samples from the burial matrix were dated to 2130–1890 cal BC and 2030–1880 cal BC (SUERC-32865 and -32866 respectively), all at 95.4% confidence.

Above the in situ elements of the burial were several loose, disturbed deposits, up to 0.05m thick (see illus 9 and 10). Two deposits of soft grey clay silt lay at the north-west end of the cist (context 11) and in the south-east end (context 18); the latter lay against the right pelvis and overlapped the black burial matrix (context 19). Their white colour may be due to periods of waterlogging in the cist (see C Wilson, below). A triangular spread of dark red-brown, friable, organic sediment (context 17) lay in the north-western part of the cist, overlapping the grey clay silt, and this contained indeterminate organic material (SF16) that most likely derived from organic components of the burial (such as basketry; see Harris, below) that crumbled when they were disturbed.

On the east, this abutted a semi-circular deposit of very loose, crumbly, creamy-white sediment mixed with dark brown silt (context 15). In it lay fragments of cranium and mandible and several teeth, as well as cattle hide fibres (SF5, 9, 10, 22) and wood (SF5, 11). The right humerus lay along the deposit's south-west edge. This mixed white deposit corresponds in position and apparent character to the head as it appears in photographs taken at the time of discovery (illus 2), where the head seems to be covered in white material in which possibly woven organic remains are visible (see Harris, below).

A linear spread of friable, very fine sediment forming yellow-white crumbs (context 16) extended south-east from the head area, along the presumed line of the torso; pieces of indeterminate organic material (SF14) and a vertebra lay just within it. Again, this disturbed deposit corresponded to an area of white material visible in pre-disturbance photographs (illus 2). An organic-rich deposit of very loose, crumbly,

dark red-brown fine silt (context 12) lay across much of the rest of the interior, abutting the deposits described above. It contained abundant fragments of bone, wood and black organic material, including concentrations of fibres; like context 17, it most likely derived from the decayed and disturbed organic components of the burial. An upper arm bone (humerus), a lower arm bone (radius) and several ribs lay in this deposit towards the north side of the cist. Near the north-east corner, a very degraded bone – probably a ball joint from a long bone – lay near several fragments of organic material and wood, including part of a hazel stick covered with bark (SF4); this may correspond to the apparently bark-covered stick visible in pre-disturbance photographs (illus 2).

Along the south-west side of the cist lay a band of orange-brown silty sand (context 14), which contained thick lenses of light grey clay silt towards the south-east corner. It overlapped and was mixed at its edges with the loose organic deposit (context 12) that covered much of the interior. Towards the south it lay directly over the in situ skeletal elements described above. This may represent material that washed into the cist over time.

Two sloping deposits of loose, orange-brown gravelly sand and small stones with lenses of grey clay silt lay at the north-west end of the cist and in the south-east corner, and these appeared to have fallen in after its discovery. A large stone flake, found in the north-west corner, fitted a flake scar on a stone that had been laid to support the

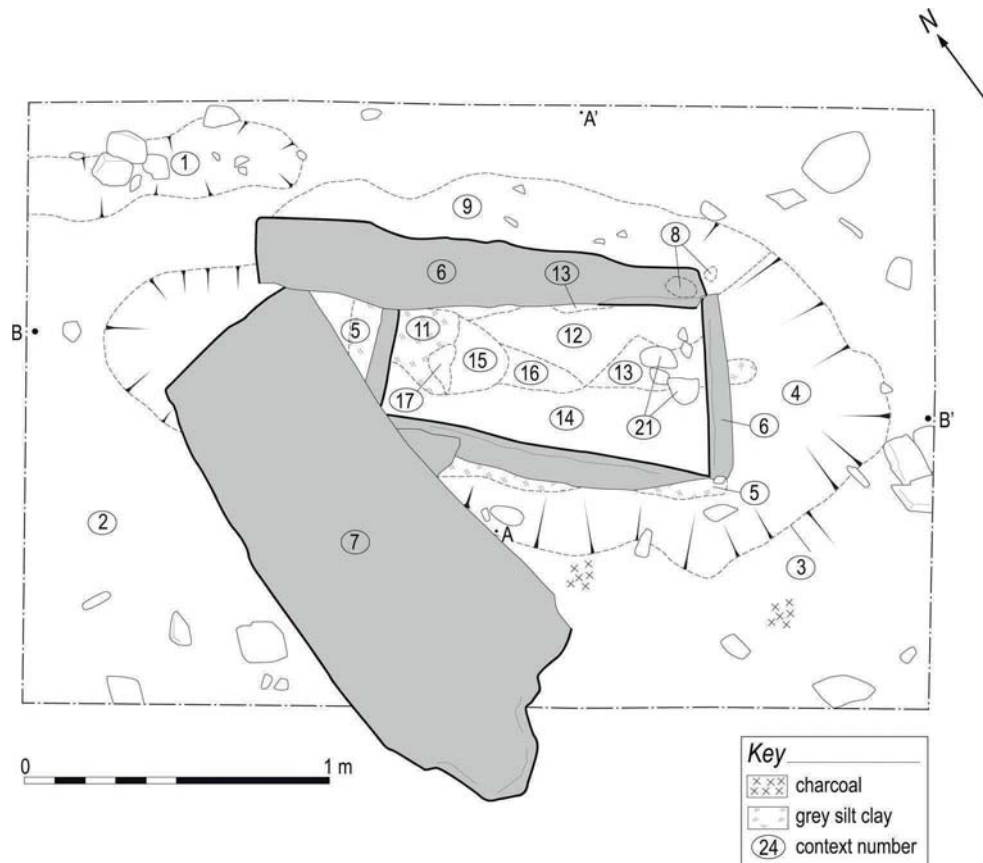

ILLUS 9 Pre-excavation plan of the cist, showing the extent of disturbed deposits



ILLUS 10 Pre-excavation photograph showing the cut for the cist

capping slab (see below); it may have broken off when the slab was disturbed by the mechanical excavator.

The construction of the cist

Excavation of the cist exterior established that it had been built by first digging a large, oval pit (context 3) through the contemporary ground surface (context 2) and the underlying gravelly sand subsoil (context 20) to a depth of about 0.75m on the north-east and south-west (illus 10 and 11). The south-east slab was taller than the others, so the builders had excavated the subsoil to a greater depth to accommodate it, while for the shorter north-west slab they had excavated only to the extent necessary on that side to create a level top for the cist (illus 11, B–B'). Bright orange sand and gravel – excavated subsoil (context 24) – had been packed around the base of the south-east slab. The floor of the cist sloped

down accordingly from north-west to south-east. As far as could be established, given the frozen conditions during excavation, the sides of the pit were just wide enough to take the vertical slabs on the north-east and south-west, plunging steeply from top to base, but the opposite sides sloped down more gradually. The interior of the cist measured just over a metre long by about half a metre wide by 0.65m deep. The slabs' surfaces appeared weathered or waterworn.

The builders had wedged small, angular stones into the corners of the cist to support the uprights – except at the north-east corner, where the slabs fit too tightly to admit any. Here, they had set several angular stones against the base of the corner along with redeposited subsoil (context 24) and had chocked a rectangular gap at the lower west corner of the south-western slab with two tightly wedged stones. They had also levelled the sloping top of this slab with a cobble, a flake from which (mentioned above) was found in the

south-west corner of the cist, where it may have been knocked off when the capping slab was disturbed. The pit around the cist was filled with orange-brown gravel and sand, presumably the mixed subsoil and topsoil which had been dug out to create it.

Clean grey clay silt (context 5) lay against and partly over the outer top edges of the slabs, and this may have been placed to lute and seal the top of the cist. After the burial, the cist was covered with the massive capping slab (contexts 6 and 7), 1.7m long by up to 0.9m wide, and 0.09m thick (illus 9 and 10). It had been broken longitudinally by the mechanical excavator and the larger portion had been dragged to one side, but a long fragment

remained in situ. The capping slab had been sealed with redeposited subsoil, which on excavation still lay 0.9m thick over the in situ fragment. This has been interpreted as the remnants of a more extensive deposit that incorporated stones – the cobbles noted in particular density around the cist in the auger survey – and which may have formed a cairn or composite barrow-cairn that covered the cist.

The subsoil around the pit was covered with a mineralised old ground surface (context 2, illus 9), consisting of firm, yellow-orange silty sand with occasional stones, patches of light-grey clay silt and charcoal flecks. The base of a plough furrow was evident as a linear hollow filled with

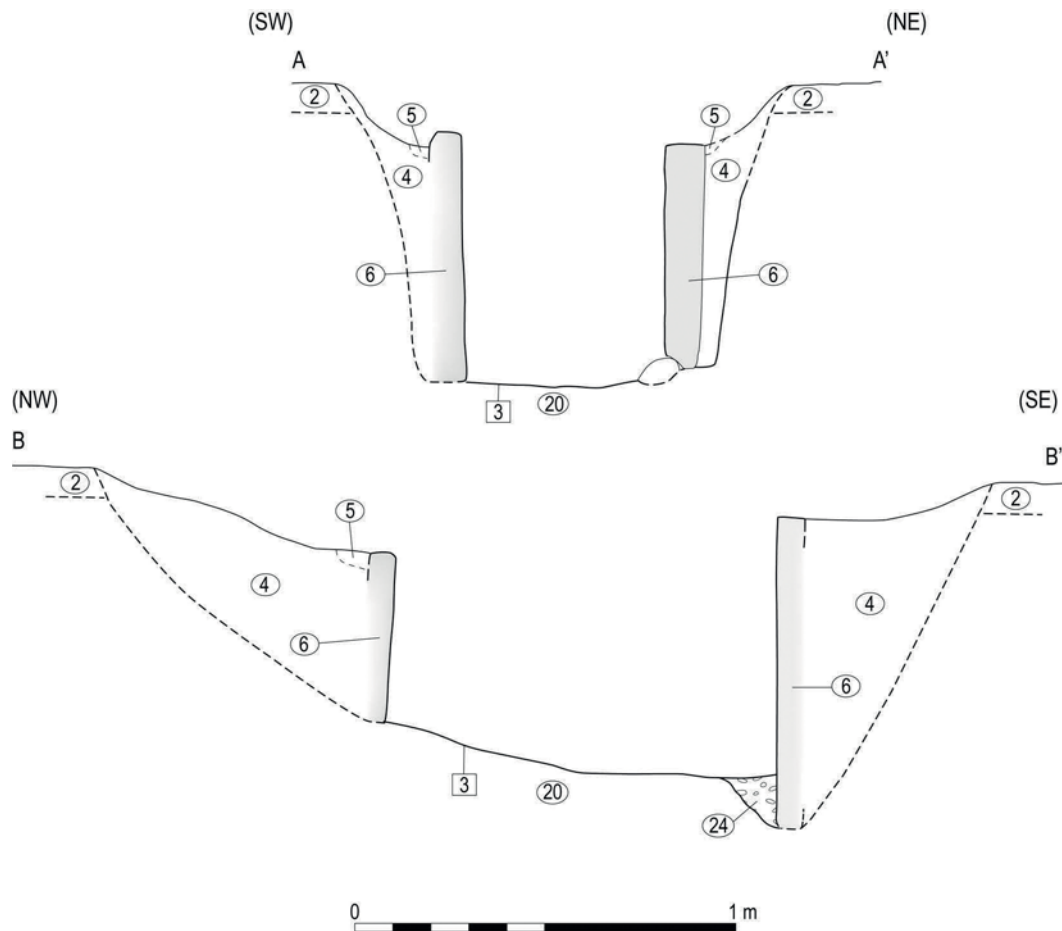

ILLUS 11 Sections across the cist structure

remnants of peaty topsoil (context 1) in the north-west corner of the trench.

POST-EXCAVATION ANALYSIS OF THE CIST

This section begins by describing the components of the burial as they were excavated and then presents the summary results of specialist analyses (osteological, stable isotope and bone histology) of the human remains, the organic remains (cattle hide, woven material, white material and plant remains) and the soils (both organic and inorganic elements). For each specialist report, method statements and detailed results are available in the archive reports.

Initially, all soil samples were sub-sampled for geochemical analysis, and further sub-samples were taken from appropriate contexts where traces of material of indeterminate character were observed before and during the excavation, so that these could be subjected to other testing for the presence of human tissue/adipocere, mineral salts and so on. A sub-sample from each bulk sample was floated for the recovery of fly pupae, ticks, carbonized plant macrofossil remains and artefacts, and the dried retents were sorted to extract different categories of material. Concentrations of white material observed in the sub-samples were also extracted. Personnel handling the material wore latex gloves at all times.

The different strands of specialist analysis were designed to maximise information from the retrieved material in order to shed light on the occupant(s) of the cist and to explain how the burial was put together and what had influenced its preservation. Some strands were added in response to questions raised by preliminary results in another. The 13 analytical reports that follow range from standard human burial studies (human bone and macroplant identifications and radiocarbon dating) through to a non-standard suite of soil chemical and organo-chemical analyses and studies of mammalian hair and parasites. The number and range of studies reflect the extraordinary state of preservation within the cist when it was first discovered

(illus 2). The number and range also reflect the view, both of the excavation team and Historic Scotland, that despite that initial, non-archaeological intervention in the interior of the cist, much of the potential for new information was recoverable.

The focus of the work evolved from attempts to identify the white material through attempts to understand something of the complex chains of biological and chemical processes that might have occurred within the cist. A second line of enquiry developed rapidly with the discovery of possible animal hair and then parasites within the hair. A third line sought to establish whether the apparently woven organic materials (see illus 2) were really artefacts.

In the accounts that follow, the intention is to present the results of the analyses as objectively as possible. Few of the analyses come to a simple conclusion and several fail to agree. However, the authors and Historic Scotland feel that it is important to record what was done so that, in the inevitable event of the discovery of a similar burial, both the questions and the analyses will evolve.

Skeletal analysis of the human remains

Iraia Arabaolaza

The human remains recovered from the cist were studied to establish the minimum number of individuals represented, determine the age at death and sex, identify evidence of pathology, growth and development and record metric and non-metric data. Osteological analysis followed current discipline standards and guidelines, as outlined by English Heritage (Mays et al 2002), the British Association of Biological Anthropologists and Osteologists/Institute of Field Archaeologists (Brickley & McKinley 2004) and Historic Scotland (Historic Scotland 1997).

Less than 50% of the skeleton was recovered, including the bones received from the Northern Constabulary. The bone cortex was moderately preserved, although some bones were very friable and poorly preserved. In addition, white chalky deposits were found on the skull, left pelvis, right femoral diaphysis and both tibiae. Very fine,

short fibres were also recovered around the right maxilla, pelvic region, right femur and both tibiae. The preservation of the bone and organic material from the grave may have been compromised by the police intervention, which disturbed the burial and displaced some bones.

Sexual dimorphic traits on the skull indicated the individual was possibly female, but the evidence for sex was more definitive on the pelvis, where the wide sciatic notch, the pronounced pre-auricular surface and the shape of the auricular surface indicated female sex. The individual was therefore determined to be a female.

The age at death was determined by the auricular surface, a non-complete left pubic symphysis and an unfused left posterior iliac crest. These indicators gave an age of young adult, with a range of 25–29 years. The lack of any degenerative changes on the bones and the slight attrition present on the molars corroborate this age range.

It was not possible to determine her stature, but the bones indicate she was of gracile build. The femur was platymeric, or flattened from front to back, a shape generally found in skeletons from pre-industrial societies, including in prehistoric Scottish cist burials (cf Shepherd 1986: 17–23).

While the poor preservation and partial nature of the skeleton made it difficult to identify evidence of pathology, some dental pathology was identified. Nine teeth presented dental enamel hypoplasia (DEH), a linear hypoplastic defect on the enamel representing a deficiency in the enamel thickness formation. Although this childhood stress indicator is not completely understood, its possible causes include malnutrition, anaemia and high fever (Hillson 1996). A dental anomaly caused by developmental deviation was also identified on the maxillary right second incisor, which presents a peg incisor shape. There was no evidence of caries, dental abscesses, periodontal disease or ante-mortem tooth loss. Only slight calculus, a mineralised form of plaque which forms on the tooth due to poor dental hygiene, was observed. The occlusal attrition of the teeth was slight too, which could be related to the young age of the individual and/or the lack of a coarse diet.

TABLE 1
Strontium, oxygen, carbon and nitrogen data for the Langwell Farm skeleton. * A $\pm 0.2(1s)$ blanket error, derived from the reproducibility of the NBS 120 C standard, is considered the best estimate of error for the $\delta^{18}O$ SMOW values and this results in $\pm 0.4(1s)$ error on the calculated drinking water values

Sample	ppm	$87Sr/86Sr$	mean $\delta^{18}O$ SMOW	n	Daux equation	Amt % N	Amt % C	at C/N	$\delta^{15}N$ AIR	I SD	$\delta^{13}C$ P	I SD	N
LF-09-SK1-e	123.6	0.711444	16.87	2	-8.1	14.5	41	3.3	10.03	0.2	-21.22	0.11	2

Stable isotope analysis of the human remains

Jane Evans and Angela Lamb

In order to illuminate the diet and possibly also the geographical origins of the person buried in the cist, samples were submitted for analysis of strontium and oxygen isotopes on tooth enamel and for analysis of carbon, nitrogen and sulphur isotopes on bone. Table 1 presents the data for strontium, oxygen, carbon and nitrogen isotopes.

Strontium: The strontium isotope composition is below the value predicted for this part of Scotland (Evans et al 2010), although data from this area is sparse and the geology complex. The drinking water value is within the expected range for the eastern side of Sutherland (Darling et al 2003).

Carbon and nitrogen: The carbon and nitrogen isotope composition for the individual from Langwell Farm suggests that she had a diet high in animal protein, but with no evidence of a marine component. The data have been compared with reference data from Norse-period Scottish sites of Cnip and Galson in the Outer Hebrides (Richards et al 2001; Montgomery et al 2003), Newark Bay, an Iron Age site on Orkney (Richards et al 2006) and Wetwang, an Iron Age chariot burial in Yorkshire (Jay & Richards 2006). The results are given in Table 1. The Scottish data define an array of values that result from a mixed diet of marine and non-marine protein components; the higher nitrogen values typify a marine component. The Wetwang dataset provides a reference set for a diet high in animal protein, with no evidence for any significant marine food input (Jay & Richards 2006). The Langwell Farm individual plots on the margin of the Wetwang data set. The carbon and nitrogen results from the Langwell individual are also consistent with the preliminary results reported from the Beaker People Project, which analysed a large dataset from the main areas of Beaker burial across the UK (Jay et al 2012).

Sulphur: The application of sulphur isotope analysis to archaeological material is relatively new, but can illuminate both palaeodiet and residency or mobility (Richards et al 2001; 2003; Privat et al 2007). Sulphur is a vital nutrient for

TABLE 2
Sulphur data for the Langwell Farm skeleton

Identifier 1	$\delta^{34}\text{S VCDT}$	1 SD	n	% S	Amt % N	Amt % C	Amt % S	at C/N	at C/S	at N/S
LF09-SK1	16.6	0.25	2	0.20	14.5	41.0	0.20	3.3	544	165

animals, and an animal's sulphur composition derives from its food intake. Geology and soil processes influence the sulphur isotope signatures deriving from plant food intake. Near the coast, sea spray can deposit marine sulphur and potentially blur the terrestrial/marine $\delta^{34}\text{S}$ distinction, but different $\delta^{34}\text{S}$ values in marine, terrestrial and freshwater producers can be used to distinguish these sources. Away from areas affected by sea-spray, $\delta^{34}\text{S}$ can distinguish between marine and terrestrially based diets (Krouse & Herbert 1988). The limitation of $\delta^{34}\text{S}$ for archaeological palaeodiet studies is that it may not be able to distinguish between truly marine diets and terrestrial diets in coastal locations due to the issue of sea spray. If it is used in combination with other paleodietary isotopes (C, N) this may aid interpretations.

The sulphur isotope signature for the person buried at Langwell Farm suggests that she had

a largely terrestrially based protein diet with possibly some freshwater fish input (illus 12; Table 2). The bone has a relatively high $\delta^{34}\text{S}$ value (16.6‰), intermediate between UK coastal and inland archaeological values when compared to data presented in Richards et al (2001).

In conclusion, the stable isotope signatures in the bone and teeth indicate that the woman buried in the cist most likely grew up in eastern Sutherland and that she ate mainly terrestrially based protein, possibly along with some freshwater fish.

Bone histology analysis of the skeletal remains

Two different radiocarbon dates were obtained from the skeleton in the cist: the right fibula was dated to 3690 ± 35 BP (SUERC-24680), while the right ulna was dated to 3615 ± 35 BP (SUERC-33918). These dates calibrate at two-sigma to 2200–1960 BC and 2130–1880

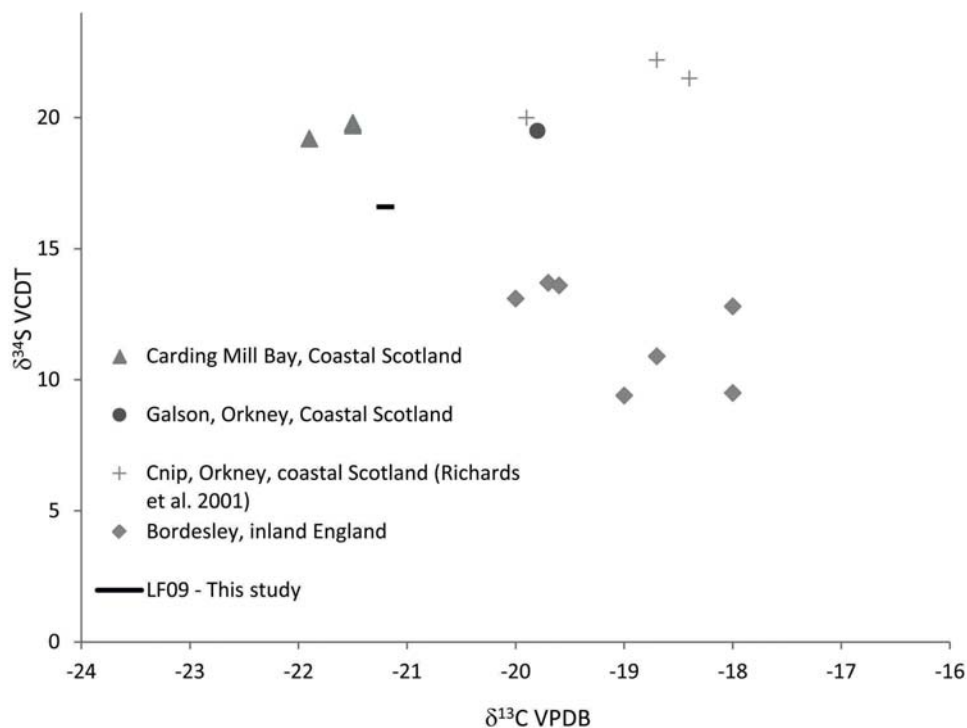

ILLUS 12 Comparison of the Langwell Farm burial's sulphur isotope composition with data from elsewhere in the UK

BC respectively. The later of these two dates is virtually identical to those obtained from cattle hide and wood from the burial (see Radiocarbon Dates and Table 19, below). However, as C^{14} starts decaying from the moment of death, the earlier date raised the possibility that the woman had been dead for a time before her remains were put in the cist.

In an attempt to throw some light on how the remains had been treated before burial, bone histology analysis (that is, analysis of the bone's microscopic anatomy) was carried out on two thin sections taken from the femur, to establish the degree of microbial attack on the bone. Thomas Booth used binocular microscopy to examine the thin sections, while Hege Hollund carried out Fourier-Transform Infrared Spectroscopy on the same thin sections. These two strands of analysis were pursued in order to establish whether decay had been arrested, which might in turn indicate whether the body was preserved in some way before burial.

Thin section analysis

Thomas Booth

Bone from the Langwell Farm cist was analysed to assess the extent to which the body had been attacked by putrefactive bacteria, which escape from the body's viscera and exploit the bone

protein in the early post-mortem period, causing small tunnels or micro-foci of destruction (MFD) (Hackett 1981; Bell et al 1996; Jans et al 2004). These MFD, representing bioerosion or diagenetic attack, are visible through microscopic examination of bone thin sections. A 1cm x 1cm section of cortical bone was cut from the anterior mid-shaft of the left femur, and two 100µm transverse thin sections (S1 and S2) were created from this, mounted on glass slides and examined by conventional binocular microscopy with normal and polarized transmitted light. They were quantitatively assessed, using the Oxford Histological Index (OHI), at the periosteal (outer), internal (middle) and endosteal (inner) surfaces of the thin sections.

The results are shown in Table 3. The bone microstructure was preserved at the internal third of the thin sections but deteriorated towards the inner and outer surfaces (illus 13), with the obliteration of collagen birefringence apparent under polarized light. Abundant microfissures were visible in both thin sections, particularly towards the outer surfaces.

The bioerosion observed was not consistent with the characteristics of bacterial attack. Rather than consisting of small discrete tunnels made by bacteria travelling through the bone (Hackett 1981), the areas of microstructural loss were large and nebulous, and more consistent

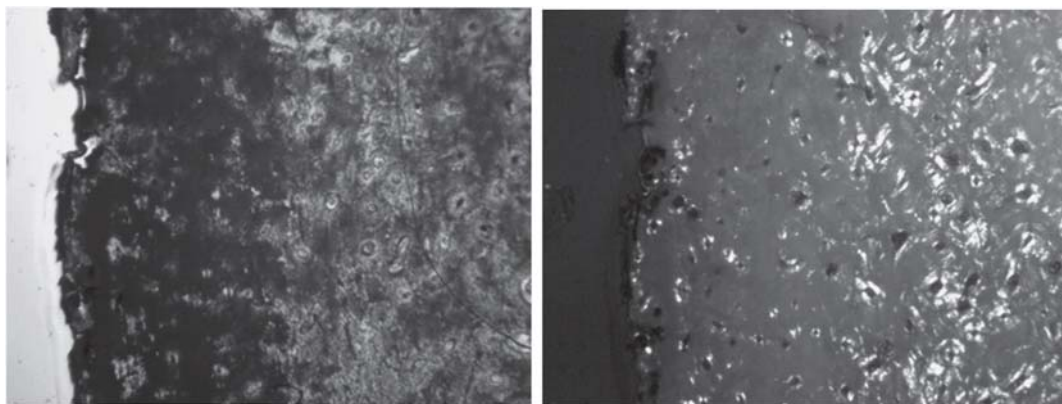

ILLUS 13 Periosteal surface of S1. Intense bacterial attack is visible as a dense accumulation of dark tunnels under normal light (left) and an absence of illuminated white collagen birefringence under polarized light (right). Width of the field of view represents 5.2mm

TABLE 3
Quantitative assessment of the thin sections

	<i>Periosteal % remaining</i>	<i>OHI score</i>	<i>Internal % remaining</i>	<i>OHI score</i>	<i>Endosteal % remaining</i>	<i>OHI score</i>	<i>Median OHI score</i>
Slide 1	<50%	2	>50%	3	>50%	3	3
Slide 2	>50%	3	>95%	5	>50%	3	3

with progressive staining, which is usually due to extraneous factors in the burial environment (Garland 1987; Schultz 1997). No MFD were observed in either Langwell thin section. It cannot be stated absolutely that the Langwell bone was devoid of any microbial attack, as any MFD present could have been obscured by the intense staining, which was probably caused by the infiltration of humic acids. (This supports the bulk soils analysis findings that the soil pH was low when the Langwell remains were first interred and that periodic waterlogging occurred (C Wilson, below), although the burial context could not have been highly acidic as corrosive environments normally promote catastrophic bone dissolution (Nielsen-Marsh et al 2007; Smith et al 2007).)

The articulation of the Langwell remains should have prohibited the bones from retaining a good level of histological preservation (Jans et al 2004; Nielsen-Marsh et al 2007). During putrefaction, the decaying alimentary tract of an intact cadaver provides abundant deleterious bacteria that can transmigrate and gain access to the bones via the circulatory system, which they can enter within 24 hours of death (Child 1995; Bell et al 1996). Bacterial bioerosion usually engulfs most of the internal bone microstructure. It is the most common form of diagenetic attack observed in archaeological bone from articulated individuals (Hedges et al 1995; Turner-Walker et al 2002; Jans et al 2004), and levels of bacterial attack are due mainly to treatment or environmental conditions rather than other possible intrinsic influences such as diet or disease (Jans et al 2004; Nielsen-Marsh et al 2007). Therefore, putrefaction of the Langwell body must have been arrested at

an early post mortem stage, inhibiting bacterial bone erosion.

Bodily putrefaction and related bone bioerosion can be arrested in several ways. Excarnation (exposure above ground or in an open cist) is one way, as it means bodies are rapidly skeletonised by carnivores and insects (Simmons et al 2010) and gut bacteria have less opportunity to attack the bone; however, as it results in at least partial disarticulation, it can be discounted in this case. The cattle hide wrapping around the body could theoretically provide an alternative explanation. There have been no direct studies of the relationship between bone bioerosion and wrapping of a corpse, although there have been some investigations into the effect of wrapping on overall bodily putrefaction. In a retrospective experimental study of human cadaver decomposition rate in a variety of contexts across southern Arizona, Galloway et al (1989) found that the putrefaction of clothed or wrapped bodies was commonly retarded when a body was wrapped in semi-permeable, absorbent material that wicked away moisture. However, at Langwell, the water-resistant cattle hide wrapping would most likely have kept the body wet by trapping moisture.

Mant's (1987: 68) study of decomposition among Second World War soldiers buried in various contexts found that, in wet conditions, the absorption of moisture by clothing and wrappings encouraged the hydrogenation and hydrolysis of body fats, resulting in the formation of adipocere. Adipocere is difficult to break down, and its formation slows bacterial decomposition of soft tissue and could theoretically affect putrefactive bioerosion of bone microstructure (Mant 1987; Aufderheide 2003; Forbes et al 2005b). SEM-

EDS analysis of samples of white material from the cist established that they were the product of bone recrystallisation (C Wilson, below). Chemical signatures indicating decomposition products were detected in the soils underneath the skeleton, but it is unclear whether they were diagnostic of adipocere (Keeley et al, below). Adipocere is most susceptible to degradation under anoxic conditions and it is possible that frequent waterlogging in the cist eventually caused the breakdown of any previously formed adipocere (Fielder & Graw 2003; Forbes et al 2005b).

Adipose formation is notoriously variable within and between separate individuals, and the precise circumstances required for adipocere development remain elusive (Fielder & Graw 2003; Forbes et al 2005b; Ubelaker & Zarenko 2010). The extent to which wrapping encourages adipocere formation is probably quite variable and reliant on factors such as tightness, level of contact with the skin and type of material (Mant 1987; Forbes et al 2005b). At Langwell, the wrapping combined with the wet burial conditions might have encouraged adipocere formation (Mant 1987; C Wilson, below). However, even when adipocere does develop, its distribution rarely prevents the decomposition of an entire cadaver (Forbes et al 2005b; Ubelaker & Zarenko 2010). Therefore, while adipocere could have affected the progress of bacteria through the internal bone microstructure, the inconsistencies and variability associated with adipocere formation mean it is unlikely that this process alone would efficiently inhibit putrefactive bacterial attack to the extent that the bones remained unaffected by bioerosion. Based on the current evidence, wrapping of the corpse does not provide a satisfactory explanation for the bone's excellent histological preservation.

The persistent waterlogging of the Langwell cist might provide an alternative explanation, as this creates an anoxic environment that can stunt cadaveric putrefaction and arrest biotic decay of the internal bone microstructure (Hollund et al 2010). Turner-Walker & Jans (2008: 232) observed that waterlogging had inhibited microstructural bioerosion in Mesolithic bones recovered from the Vale of Pickering, North Yorkshire, and Neolithic human remains from

Ypenburg in the Netherlands, which had small concentrations of MFD below their periosteal (outer) margins. Waterlogged skeletons from the post-medieval cemetery at Carver Street, Sheffield, South Yorkshire, examined by the author demonstrated similar patterns of limited microstructural bioerosion, although the extent of the bacterial incursion was much more variable here. However, waterlogging rarely disturbs putrefaction rapidly enough to entirely prevent the appearance of MFD (Turner-Walker & Jans 2008). All of these examples demonstrated some level of bacterial attack, and most showed considerably higher levels of bioerosion than the Langwell bone.

That said, if the cist had been waterlogged within the first few months of burial, this could explain the good histological preservation. Five out of six articulated Roman skeletons, interred soon after death in anoxic marine clay sediments at Castricum in the Netherlands, had histological preservation comparable to the Langwell bone (Hollund et al 2010). Estimates for the timescale of MFD in a naturally putrefying body vary, but the earliest they have been observed to occur is three months after death (Bell et al 1996; White 2009). The survival of organic grave goods at Langwell would suggest that the context was waterlogged at an early stage, before they had decomposed, although it is likely that the body would have decomposed more quickly than the grave goods.

The question remains: is there evidence that the Langwell body was intentionally mummified? Anthropogenic mummification practices arrest cadaveric putrefaction by neutralising detrimental bacteria or by rendering the soft tissue immune to bacterial action (Aufderheide 2003). The few histomorphological studies of bone from mummified individuals that still retain their preserved soft tissue have consistently recorded immaculate levels of microstructural preservation, with no signs of bioerosion (Weinstein et al 1981; Thompson & Cowen 1984; Stout 1986; Brothwell & Bourke 1995; Hess et al 1998). The histological preservation at Langwell is consistent with that observed on mummified remains. If the Langwell remains had been mummified, then the technique used must have efficiently compromised the

visceral bacteria soon after death. The level of histological preservation would also be theoretically consistent with evisceration, although this process in itself would increase the overall chances of soft tissue preservation.

At the Bronze Age settlement site of Cladh Hallan, South Uist in the Outer Hebrides, DNA and osteological analyses of two bodies showed they were composed of formerly mummified elements of three different individuals who had died at different times (Parker Pearson et al 2005; 2007; Hanna et al 2012). If the Langwell remains had been mummified then this would provide a possible explanation for the differences in radiocarbon date ranges obtained from right fibula and right ulna.

In conclusion, histological analysis revealed that the Langwell bone had been subjected to mild levels of acidic erosion and had been infiltrated by humic acids, both consistent with

the characteristics of the burial environment. The bone microstructure demonstrated no visible evidence of bacterial erosion, suggesting that microbial attack had been halted soon after death, probably leading to prolonged – but temporary – soft tissue preservation.

It is difficult to identify the specific taphonomic process that prevented putrefactive bacteria from attacking the internal bone microstructure. The simplest answer is that the cist was waterlogged within a few months of burial, but the diagenetic signature is also consistent with mummification or evisceration. The integrity of the thin sections more closely matches the consistently high levels of microstructural preservation recorded on mummified individuals than the variably preserved histology observed on bone from waterlogged contexts (Weinstein et al 1981; Thompson & Cowen 1984; Stout 1986; Brothwell & Bourke 1995; Hess et al 1998; Turner-Walker & Jans

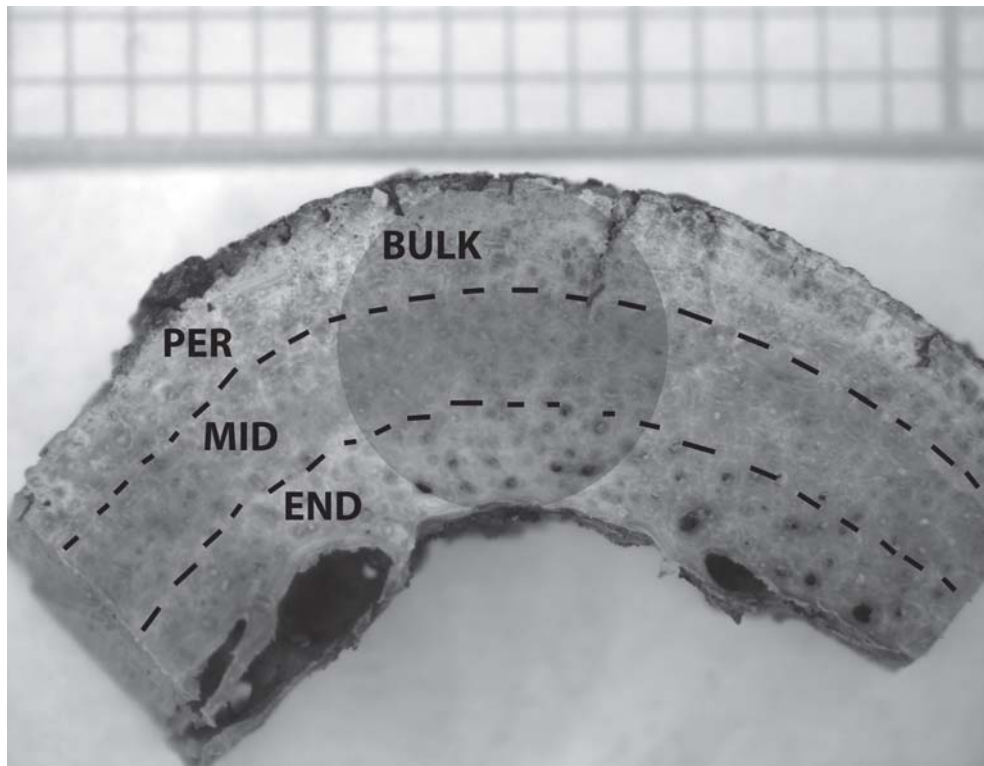

ILLUS 14 Microscopic image of the bone sample, showing zones sampled for FTIR analysis

TABLE 4
 Splitting factor (SF), Carbonate/phosphate ratio (C/P) and amide/phosphate ratio (Am/P) of the Langwell cist sample aliquots, calculated on the basis of FTIR-spectra. The archaeological bone values are averages of three replicate measurements. The fresh bone values are based on eight replicate measurements of modern cattle bone. Sd = Standard deviation

<i>Sample</i>	<i>SF</i>	<i>Sd</i>	<i>C/P</i>	<i>Sd</i>	<i>Am/P</i>	<i>Sd</i>
Bulk	3.96	0.19	0.22	0.01	0.33	0.01
Periosteal zone	4.07	0.07	0.22	0.01	0.31	0.01
Middle zone	4.15	0.28	0.23	0.01	0.35	0.01
Endosteal zone	4.04	0.15	0.26	0.03	0.38	0.04
Fresh bone	3.17	0.14	0.34	0.02	0.32	0.01

2008). However, waterlogging soon after burial still stands as a plausible explanation. The two interpretations need not be mutually exclusive. The same diagenetic signature would be observed

had the Langwell body been mummified and then waterlogged. Under these circumstances, it is impossible to say for certain whether the Langwell individual was intentionally mummified and this

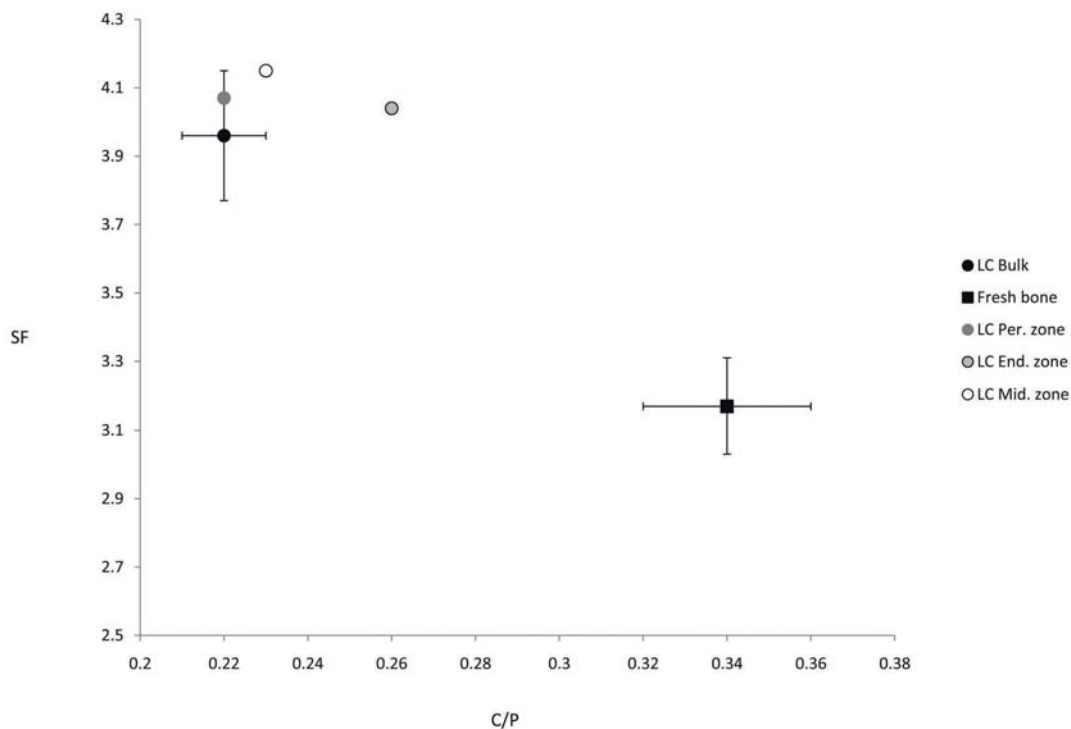

ILLUS 15 Graph displaying the C/P versus SF values of the Langwell Cist aliquot samples, compared to those of fresh bone

cannot be dismissed as a possible explanation for the histological preservation and the slight differences in the calibrated ranges for the radiocarbon dates.

FTIR analysis

Hege Hollund

Archaeological skeletal material undergoes a range of different physico-chemical alterations (known as diagenesis) during burial; the type and rate of alteration depend on the burial conditions (Hedges et al 1995). The state of the bone thus reflects the burial environment and changes within it. Fourier-Transform Infrared Spectroscopy (FTIR) is a method commonly used to investigate the degree of alteration in buried archaeological bones; it gives information on both the crystal structure and chemical composition of the material (Weiner & Bar Yosef 1990). The method used to analyse the Langwell bone was FTIR-ATR (Stathopoulou et al 2008; Thompson et al 2009), which utilizes an attenuated total reflection (ATR) accessory. Bone powder for analysis was drilled from the same 1cm×1cm section taken from the left

femur as that used for histological analysis (Booth, above; illus 14).

Table 4 details all the parameters for the bulk bone, the periosteal (outer) zone, the middle/internal zone and the endosteal (inner) zone samples, obtained by FTIR-ATR. The values made on fresh cattle bone are also reported for comparison and the SF and C/P values are shown graphically in illus 15.

The values indicate that the inner zone is somewhat better preserved than the outer-middle zone, with higher collagen content (see illus 16). Overall, the organic phase is well preserved, while the bone mineral has undergone substantial alteration. The changes are consistent with a wet and neutral to slightly acidic environment, allowing for the dissolution and recrystallisation of the bone mineral. The alterations of the material as found by FTIR are thus consistent with what is known about the burial environment within the Langwell cist.

Bone histology conclusions

The thin section light microscopy and FTIR analyses of the Langwell Farm skeleton reached similar conclusions. The microfissures observed

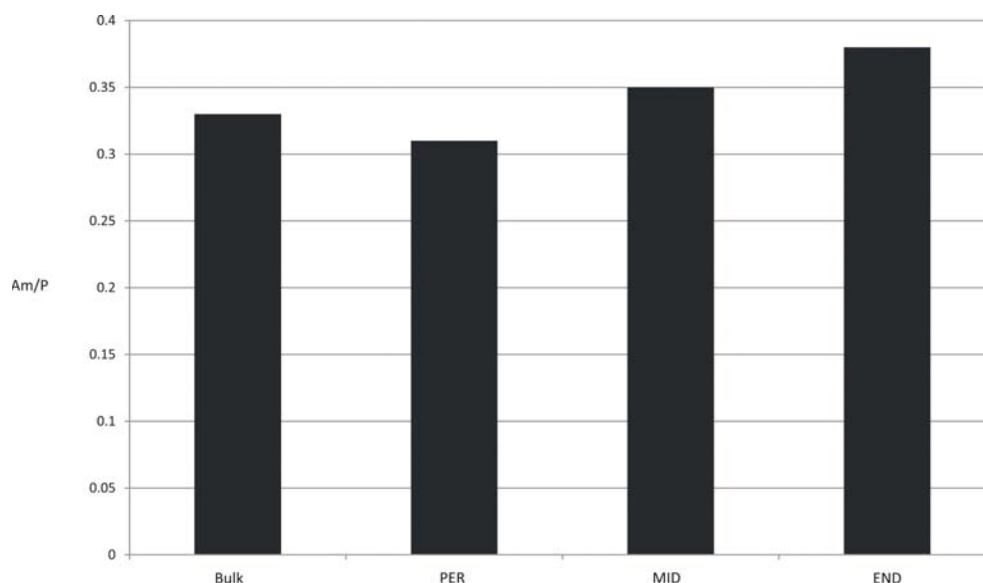

ILLUS 16 Am/P values of the four sample aliquots from the Langwell cist bone



ILLUS 17 Well-preserved cattle hide sample from context 15. The roots are at the top and the tips at the bottom.
Scale in mm

towards the outer surface of the Langwell thin sections coincide with substantial increases in crystallinity recorded by the FTIR. These observations are consistent with the bone having been subject to diffuse acidic erosion in the slightly acidic burial conditions of the cist (Gordon & Buikstra 1981; Smith et al 2007; Turner-Walker & Jans 2008). The high collagen content of the Langwell bone recorded by FTIR is concordant with the excellent levels of histological preservation and lack of bacterial exploitation observed in the thin sections.

The FTIR analysis reported some level of protein loss towards the outer surface of the Langwell sample. This could indicate minor bacterial attack that went undetected in the thin sections because of the obtrusive humic

staining, but the lack of observable bacterial attack in the visible outer zone of the thin sections suggests that the protein loss was more likely due to extraneous acidic degradation. The conclusions from both methods are in accord: the diagenetic signature of the Langwell bone is consistent with mummification, but could equally have been promoted by waterlogging shortly after burial.

Brown cattle hide

Penelope Walton Rogers

THE ANGLO-SAXON LABORATORY

Animal fibre from the cist fills and associated with the human remains was analysed to determine its origins. Tufts of animal fibre were collected

from the cist as 10 spot finds (SF numbers) and a further 19 specimens emerged during post-excavation processing of the bulk samples (BS numbers), making 29 fibre samples for study. The positions of the spot finds were marked on the grave plan during excavation and the relationships of the individual bulk samples to the skeleton and the grave cut were recorded as the samples were collected. This extensive sampling and commendable record-keeping in the field allowed the full potential of the material to be realised in the laboratory.

Each specimen was first viewed with a $\times 10$ microscope, to establish the general character of the material, and then fibres were mounted for optical (transmitted-light) microscopy at magnifications up to $\times 640$. For the identification of animal species, the diagnostic features are the range of diameters, the cuticular scale pattern, the frequency and type of the medulla (central channel), the shape in cross-section and the distribution of pigmentation. In our laboratory, these features are recorded and then compared with standard fibre atlases (Wildman 1954; Appleyard 1978; Textile Institute 1975) and a collection of modern specimens.

The specimens all came from the fill of the cist, in contexts 12, 14, 15, 18 and 19 (illus 7 and 9); the best preserved and most extensive remains came from close to or on the body (illus 17). In all but the most broken examples the roots and tips of the fibre were present (illus 18a–b), and in some instances, remains of skin were preserved around the roots. All specimens proved to be essentially the same and very probably came from the same animal, although they varied in length (see Catalogue, below). Most intact tufts were 15–25mm long, but there were some only 7mm long, along the south-west side of the cist in context 14. It is possible that these represent the top of the animal's legs, where the hair is shorter, and therefore the edge of the hide.

The species could be confidently identified as cattle from the following features. The fibre diameters were 24–87 μm and most were between 30 μm and 65 μm . The scale pattern was irregular mosaic with smooth near margins (illus 19a), changing to rippled margins from mid-shank to tip (illus 19b). Medullas were rare and, when present, mostly narrow and fragmented (illus 19c), or occasionally wide in the coarsest fibres (illus 19d). Cross-sections were consistently oval (illus 19d).



ILLUS 18 Cattle hide fibres, showing root (a) and tip (b). Micrographs taken with $\times 40$ objective and camera zoom

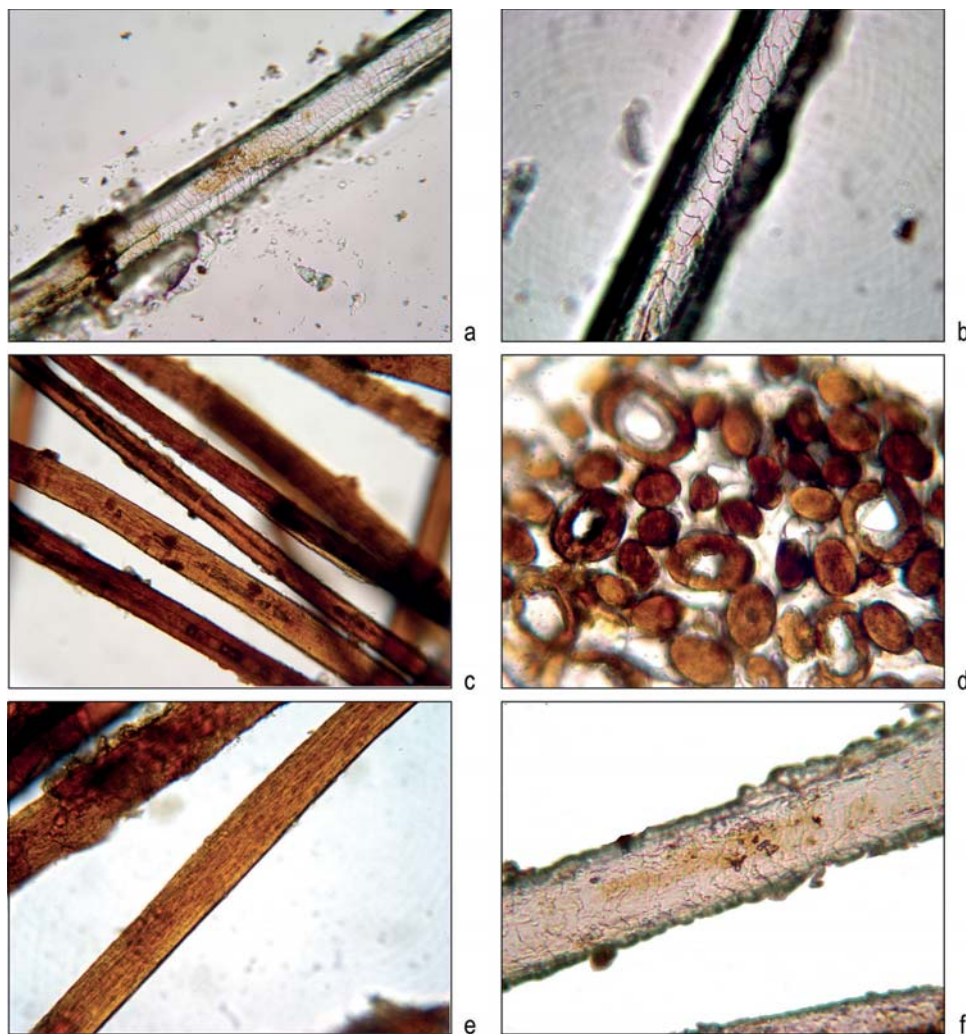

ILLUS 19 Fibres showing the diagnostic features of cattle hair. (a)–(b) Casts of the scale pattern on medium-diameter fibres, (a) with smooth scale margins and (b) with rippled margins towards the tip; (c) fibres with medullas; (d) oval cross-sections with and without medullas; (e) with the focus adjusted to view the internal pigmentation; and (f) a cast of a coarse tail fibre. Micrographs taken with $\times 40$ objective and camera zoom

Pigmentation was light to moderate throughout (illus 19e), indicating a uniformly brown beast. The hide must have come from an adult animal as calf hair has a different morphology (Appleyard 1978: 50; Textile Institute 1975: 67 (note that in this figures 34a and 34b appear to be reversed)). Some of the coarsest fibres from SF5, context 15, had the irregular scale pattern and close rippled-crenate margins of tail fibres (illus

19f) (Wildman 1954: 139; Appleyard 1978: 49).

This, then, represents the remains of a brown cattle hide, including – probably – the top of the legs and the root of the tail. The hide ran under the body in context 19, but the remains were particularly dense in the centre of the grave and appeared to pass over the body in context 14. Given the position of the tail end by the skull and the probable edge to one side of the

body, it seems likely that the hide was wrapped around the corpse with the head end by the body's feet and the long edges together on the south-west side of the cist. It was impossible, however, to determine whether the hair side faced inwards or outwards. Although there is no direct evidence for this from the excavated material, it seems likely that the hide would have been de-fleshed, cured and dressed with fats or oils before use.

In a temperate climate, animal pelts and hides are preserved only in particular soil conditions (mostly waterlogged ones such as peat bogs) and the Langwell hide is therefore a relatively rare survival. On the other hand, such evidence as exists for burial with hides stretches from Finland to Ireland and from the Bronze Age to the medieval period (Hald 1980: 313, 380), and it may have been a more common practice than the small numbers recovered in Britain would suggest. In an Early Bronze Age inhumation at Ingleby Barwick, Teesside (Grave 6), for example, the hide was preserved by association with a corroding metal armlet and, if there had been no metalwork in the grave, its presence would have gone undetected (Walton Rogers 1999). Ellen McAdam has detailed 10 burials with animal skins in Scottish cists and has argued that they were associated with individuals of special status (McAdam 1982: 126–7; Watkins 1982: 61–2).

In four Aberdeenshire cists, the animal skin was interpreted as a cover for the body and that was probably also the case at Ingleby Barwick, where the hair appeared to face upwards, on the upper face of the armlet. At Masterton, Pitreavie, Fife, the hide covered the floor of the cist – and skin remains under the head were recorded at Barns Farm Cist 1, Dalgety, Fife, and Cunighar, Tillicoultry, Clackmannanshire (McAdam 1982: 127). There are no other examples from Britain where the body had been wrapped, but in a coffin burial in Egtved, Denmark, a clothed woman had been laid on a cattle hide, with the hair side facing upwards, and the edges folded over the body (Broholm & Hald 1940: 78, fig 100). In the medieval period, bodies were sometimes stitched into hides in Britain, Denmark and Iceland, which may represent a survival of an earlier practice (Hald 1980: 380; Gilchrist & Sloane 2005: 107).

As well as inhumations, remains of cattle hide and other animal pelts have been found with cremation urns of the Iron Age and early medieval periods (Walton Rogers 2005).

Few of the animal pelts from the Scottish Bronze Age have been classified more closely than 'bovine' (and one pelt proved to be fur, possibly from stoat), but the example from the Masterton cist was identified as 'bovine, probably European bison or aurochs' (McAdam 1982: 127). Bison seems unlikely in the British Bronze Age, but another bovine hide from Neolithic Meare, Somerset, had a fine undercoat, which might indicate wild ox (aurochs) (Ryder 1969: 517–18).

The Langwell hide has none of the diagnostic features of bison (Wildman 1954: 140–1) and no fine undercoat. Instead, it has all the characteristics of modern domestic cattle. In colour it was probably a uniform mid- to light brown, and can be compared with the light-brown pigmentation in the remains found with an early historic urn at Stromness, Orkney (Walton Rogers 2005), and in hide bags from Iron Age Hallstatt in Austria (Ryder 1992: 63–4), and also with the mid-brown pigmentation of the remains associated with a less securely dated urn from Sebay, St Andrews, and Deerness, Orkney (Walton Rogers 2005: 165–6). A cattle-hide cape from Derrykeigan, Co Antrim, Ireland, radiocarbon-dated to the 1st century AD (Walton Rogers n.d.), was piebald (black and white or dark brown and white) – and remains of a probable cattle hide from an Arras Culture burial on Skipwith Common, Yorkshire, were very pale to the naked eye (Bender Jørgensen & Walton unpublished). It would appear that by the time of the Roman Iron Age, there was a range of different colours in cattle in the British Isles, although only mid- and light brown have as yet been attested for the Bronze Age.

NB: Analysis of stable isotopes in the cattle hide could, in theory, have shed light on the animal's geographical origins; however, given the limited amount of reference material for this relatively new procedure (P W Rogers pers comm), any results were not likely to be particularly informative, and so it was decided this strand of analysis would be an unwise use of resources.

Catalogue of animal fibres from the cist

CONTEXT 12: ORGANIC-RICH BURIAL MATRIX

<i>SF No</i>	<i>Grid square</i>	<i>Condition</i>	<i>Description</i>	<i>Size</i>
SF1	—	Dry	>10mm (incomplete)	24–65µm
SF2	C5	Wet	20–25mm (tips and roots)	34–80µm
BS005a	—	Wet	15mm (tips and roots)	29–50µm
BS005b	—	Dry	Skin present	—
BS017	B4	Wet	13mm (roots only)	40–56µm
BS023	C4	Wet	>8mm (roots and some tips)	31–51µm
BS025a	C6	Wet	Disaggregated (roots and tips)	—
BS025b	C6	Dry	Disaggregated (tips only)	37–77µm

CONTEXT 14: MATERIAL OVERLYING BURIAL ON S

SF15	A4	Dry	25–30mm (poor pres.)	34–50µm
SF19	B6	Dry	18mm (poor preservation)	—
BS011a	A4	Wet	7mm (tips and ?roots)	30–51µm
BS011b	A4	Dry	7mm (tips and roots)	—
BS013	A6	Dry	Skin with a few fibres	—
BS018/019	B5–6	Wet	Disaggregated	—
BS039a	B4	Wet	15–20mm (skin and tips)	34–60µm
BS039b	B4	Dry	>10mm (?)	34–60µm

CONTEXT 15: BURIAL MATRIX WITH ?DECAYED BONE

(a) SF5	B2	Dry	15–18mm whole pelt	
Disaggregated (roots and tips)		25–65µm		
—				
SF11	B2	Wet	30mm (roots and tips)	26–73µm
BS032	B2	Dry	>6mm (poor preservation)	—

CONTEXT 18: MATERIAL LAID WITH BURIAL

BS035	A5	Dry	>6mm (poor preservation)	20–87µm
-------	----	-----	--------------------------	---------

CONTEXT 19: STAINED BURIAL MATRIX

SF18	B5	Dry	15mm (roots and tips)	30–60µm
SF23	—	Wet	12mm (roots and tips)	24–70µm
SF24	—	Wet	12mm (roots and tips)	24–70µm
BS038	B4	Wet	— (incomplete)	24–61µm
Sample from R femur	—	Wet	20–25mm (tips only)	26–70µm

CONTEXT 24: PACKING MATERIAL FOR E SLAB

SF27	—	Wet	c 10mm (incomplete)	—
------	---	-----	---------------------	---

Samples collected from skeleton without context numbers:

Broken remains of fibres were recovered from the right and left tibia and the right femur.

Those from the right femur were 20–25mm long (tips only) and 26–70µm diameter.

Woven material

Susanna Harris

What appears to be woven material resembling basketry was observed in the photographs of the Langwell Farm cist taken shortly after the cist's discovery, before the removal of some of the contents by police (illus 2). Mr Jonathan Hampton, landowner and eyewitness at the cist opening, also recounted that some areas of the skeleton appeared to be covered with woven material resembling basketry (O Lelong pers comm). Although none was identified in the post excavation analysis, this could be the result of the cist disturbance; decayed textile and basketry remains are often rendered incredibly fragile and can readily turn to dust if handled heavily.

This report is based on the visual examination of eight photographs taken shortly after the cist's discovery and before police disturbance (IMG-0322 to IMG-0330, excluding the blurred IMG-0323). They are jpeg image files of 3072×2304

pixels, resolution 180 dpi at an image size of 433×324mm, colour representation sRGB – a reasonable specification for a compact camera, but not high enough to allow significant zooming to examine details. The photographs show several views of the cist contents with different fields of focus. Any analysis based purely on photographic sources has certain limitations: fibre analysis is not possible, the identification of elements and fabric structure is compromised, and measurements are only approximate. Therefore, this analysis cannot lead to the same clarity of results as would be expected from an examination of the preserved artefact. Nonetheless, whatever comment on the woven material is possible from the available evidence can provide a more holistic view of the grave contents and the burial procedure, especially the wrappings.

Three areas were identified which may contain woven material: the leg region, the top of the skull and a small central area (illus 20). The leg area will be described first, as this is the



ILLUS 20 Three areas of possible woven material taken before the contents of the cist were disturbed: leg area (to right), small area in centre and on top of skull (left)

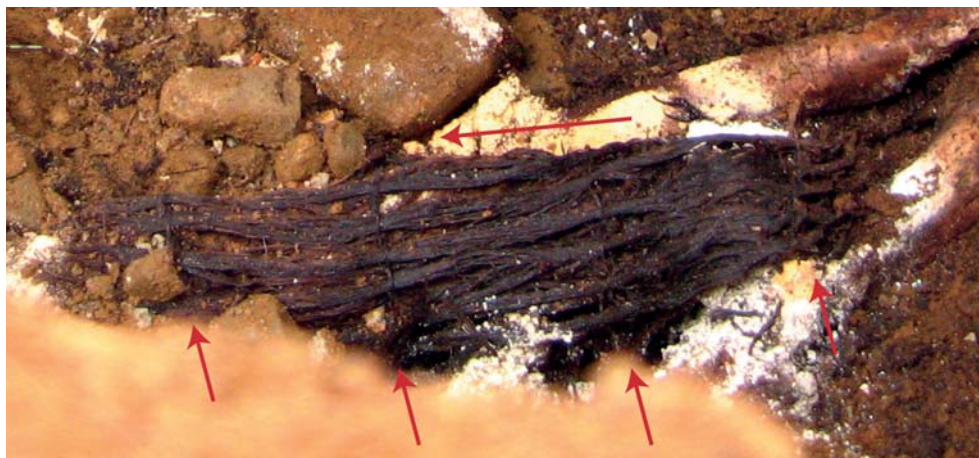

ILLUS 21 Woven material in the leg area. The large arrow shows the position of the fibrous bundles of the first set of elements; the four smaller arrows show where they are interworked with a second set of elements

most readily identified. The discussion employs the more neutral terminology of first and second set of elements, which is preferable when it is not possible to technically distinguish the passive warp from the active weft.

Woven material in the leg area: The area of woven material over the leg area measures approximately 530 × 130mm. It consists of six rows of dark black-brown elements (first set) running in a north/south direction. These are crossed at right angles in three or four places by much finer elements (second set) of the same colour. This falls into the ‘two or more sets of elements’ fabric structure, in which one set of roughly parallel longitudinal elements is interworked at right angles with a second set of elements (Emery 1966: 74).

The first set of elements has a maximum length of approximately 530mm and each element has a diameter of approximately 5–15mm. They consist of long, fibrous bundles that show no spin or twist, and can be described as not spun, single elements (Emery 1966: 9). They are aligned in roughly parallel rows separated by narrow gaps, through which the underlying deposit is visible. The second set of elements is much less distinct; single rows can be seen crossing the first set and, where they do, drawing them in slightly (illus 21). There are only three or four rows, each spaced

80–120mm apart. Two rows can be seen quite clearly; a third row to the south end is much less distinct and covered in part by a small stone or area of soil, and a possible fourth row at the north end is very indistinct and partly covered by soil. The elements of the second set are significantly finer and measure approximately 2mm in diameter, and are not clearly enough defined to identify twist or spin direction.

Woven material on top of the skull: The area of woven material on top of the skull measures approximately 350 × 125mm. It is dark brown and largely covered by a white substance. It appears to have a colour and similar fabric structure to the woven material in the leg area.

The first set of elements runs roughly north-east/south-west, curving as if following the shape of the skull. Where visible, these appear to be fibrous bundles measuring 5–15mm in diameter, with no spin or twist and a maximum length of 350mm. The second set of elements is barely visible beneath the white substance. Where this is absent, they can be seen intersecting the first set of elements in several places, in rows spaced 80–100mm apart. Although much is obscured beneath the white substance, the position of the rows is emphasised where they slightly depress the fibrous bundles of the first set of elements.

The colour, elements and fabric structure appear very similar to those in the leg area.

Possible woven material in central area: The possible woven material in the central area is very indistinct. It measures approximately 60 × 100mm and consists of three short, parallel, dark brown sections with what appears to be an element intersecting at right angles, in a manner similar to the woven material of the leg area and on top of the skull. This small patch could suggest that all three areas of woven material were once part of a large sheet that covered the body. However, the areas are surrounded by other dark material that could be fragments of wood or fur of a similar colour. Therefore, this can only remain a speculative hypothesis.

Fabric structure

The fabric structure is composed of two sets of elements intersecting at right angles. The fibrous bundles of the first set of elements rest slightly apart from one another (the underlying deposit can be seen through the gaps) and they appear drawn-in where they are intersected by the second set. These features occur in a fabric structure called twining, in which pairs of adjacent elements from one set cross-twist with each other, enclosing the successive elements of the other set (Emery 1966: 196). When the second set of elements is widely spaced, as here, it is called open twining (Adovasio 2010: 16) (illus 22). These pairs of

cross-twisting elements, which are here described as the second set of elements, can appear as a single row. Due to this cross-twist formation, the fabric remains structurally sound even when the rows are spaced apart, as in this example. As the cross-twist wraps around the first set of elements, it may have the effect of squeezing them slightly, creating the drawn-in feature seen here, while also holding them slightly apart, hence the gaps.

Without first-hand examination of the preserved artefact, this remains a theory based on the interpretation of the photographs. It cannot be completely ruled out that this could be another type of fabric structure, such as coiled basketry, plaiting or wickerwork. However, the twining (cross-twisting) interpretation seems most likely and the photographic evidence suggests that the skeleton was buried with material woven using this technique, perhaps as a cap and also a cover over at least the lower part of the body

Comparative material

There has been relatively little examination of Bronze Age basketry in Scotland, but Henshall's (1950) report 'Textiles and Weaving Appliances in Prehistoric Britain' does allude to the presence of twining. Henshall describes several examples of twining from British Bronze Age, Iron Age and Roman contexts which are described as pairing with a cross-twisted technique (ibid: 141–4, 151–5, 162). Several were Bronze Age cairns or cists (ibid: 153–4).

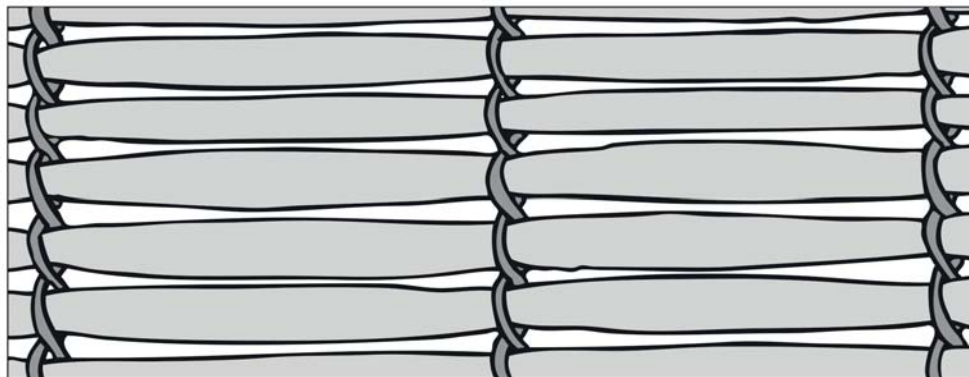

ILLUS 22 Schematic diagram of open twining. © Susanna Harris

In the 1920s and 1930s, Mann excavated organic material from several cairns or cists, including a cairn at North Cairn Farm, Corsewall, Dumfries and Galloway. Henshall describes the material as ‘small hanks with cross-binding technique separated about 3 inches apart’ [76mm] (ibid: 153). Mann compared the fabric from North Cairn Farm to other material he described as a ‘hair moss garment’, which covered the crouched inhumation of a young boy excavated from a cist at Greenoak Hill, Mount Vernon, Glasgow, and was accompanied by an early Bronze Age Food Vessel (ibid). Henshall reports that this ‘garment’ was not preserved with the rest of the cist contents at the Kelvingrove Museum (ibid).

Another stone cist excavated by Mann at Ferniegair, Lanarkshire, provided evidence of organic material covering the skeleton (ibid: 154; Welfare 1977). The very friable and fragmentary remains of this material are conserved by Glasgow Museums and have been examined by the author. As Henshall reports, the construction method of the Ferniegair matting is not apparent. However, it is possible to identify a number of dark brown, parallel, fibrous bundles with a diameter of 3.5–10mm, which are mainly preserved on the tibia bone of the inhumation (Harris unpublished). The Ferniegair skeleton was accompanied by an Early Bronze Age Food Vessel, with traces of a black substance inside (Welfare 1977: 5). The best preserved example examined by Henshall was found covering the body of an undated cist at Firth’s Park, South End, Stromness, Orkney (Henshall 1950: 153). Henshall identifies this as cross-twisting technique (that is, twining) with interspacing of approximately $\frac{3}{4}$ to $1\frac{1}{4}$ inches (19–32mm) between the hanks; the raw material was identified as *Scirpus lacustris* (ibid), or bulrush.

Twining of various sorts is known from prehistoric contexts throughout Britain and continental Europe (Gleba & Nikolova 2009; Henshall 1950: 151, 156; Médard 2010: 71–103; Rast-Eicher 2005; Vogt 1937). Other recent discoveries of prehistoric basketry in Scotland seem to belong to a more robust category of materials, usually described as wattle or wickerwork (Duffy 2006: 12–14).

In conclusion, the pre-disturbance photographs do appear to show some kind of woven material on the leg and skull area of the skeleton, identified as a fabric structure composed of two sets of elements intersecting at right angles. The woven material on the skull appears very similar to that of the leg area, although it is obscured by a white substance. The material in both areas appears to have a fabric structure called ‘open twining’ with the second set of elements, or twines, spaced approximately 80–120mm apart. This technique is known from a small number of comparative finds from Scottish Bronze Age cists and cairns and was a technique known widely throughout prehistoric Europe.

At a much more speculative level, a small patch of dark material in the central area may be the same material, which could suggest that a large sheet of woven material originally covered the whole skeleton. However, as the original woven material was not examined, the identification of open twining must be treated cautiously. What appears apparent in a photograph or at a first glance can be misleading and, without the preserved artefact, it cannot be verified. The two possible interpretations are shown in illu 29.

Microfauna

Olivia Lelong

Thirteen mites, retrieved from bulk samples from the cist and from cattle hide fibres, were analysed to identify them and shed light on how they came to be in the cist. They were identified by Dr Anne Baker at the Natural History Museum in London. All the mites were *Eulaelaps stabularis* (Koch); seven were identifiable as females and three as males. These particular mites are usually found on rodents, and wood mice (*Apodemus sylvaticus*) would have been their most likely host in the Early Bronze Age (Paul Buckland pers comm). However, they are also found in birds’ nests, refuse dumps, stable straw and grain-, hay- and strawstacks in open fields and in permanent stackyards (Griffiths 1960).

They could have entered the cist on mice that burrowed through the soil covering the cist and made a nest in the cattle hide. However, there was no other evidence for rodent disturbance in

the cist. Alternatively, their host was the cow or bull from which the hide came. They could have been picked up on the animal's bedding and fed on blood from a cut or abrasion (Anne Baker pers comm). Their presence in the hide fibres could suggest that the hide was not processed before being used in the burial rite, as tanning would have removed them.

Wood and charcoal from the cist

Susan Ramsay

Macroplant remains from the cist and its environs were studied in order to facilitate interpretation of the burial rite and the use of contemporary landscape resources and to identify material suitable for radiocarbon dating. No attempt was made to identify pollen in the samples because of the likelihood of contamination from the cist's disturbance after its discovery.

The 57 small soil and organic samples recovered from the cist were hand-sieved using mesh diameters of 2mm and 500µm, and the retents were sorted to separate all possible identifiable remains into specific categories. Fragments of charcoal, bone and white material were dried, while all other organic remains were kept wet and stored under refrigerated conditions. Three bulk soil samples were also taken and these were processed by flotation for the recovery of carbonized remains, using standard methods. The botanical remains were then examined microscopically. Many of the wood sections were heavily contaminated with fungal spores and hyphae. These sections were treated with a solution of bleach to clear them and allow the internal anatomy of the wood to be viewed under magnification.

All of the contexts from the cist interior contained charcoal or other carbonized remains, most of it occurring as tiny fragments and including alder, birch, hazel, heather type and Scots pine. These are all native to the area and could have grown near the site at any time from the mid-Holocene onwards. Context 4, the backfill around the cist exterior, also produced charcoal fragments dominated by Scots pine type, with some alder. These are likely to derive from an earlier charcoal scatter.

Other carbonized plant remains recovered from the cist include single seeds of heath grass and ribwort plantain, indicative of local grassland, while carbonized heather type flowers and a single carbonized leaf of heath grass suggest a heathland component. They may have resulted from burning of local surface vegetation at some point before the cist was built and sealed.

Fragments of uncarbonized wood were recovered from contexts 8, 10, 11, 12, 13, 14 and 15. Most were impossible to identify, even tentatively, because of significant fungal contamination. Context 12, the disturbed upper burial matrix, contained hazel wood (including SF4), which appears to be the remains of the bark-bearing stick visible in pre-intervention photographs of the burial (illus 2). The hazel wood was heavily contaminated with fungal spores and hyphae, suggesting that it had been in the cist for a considerable period of time. The only other tentative identifications came from context 10, which contained conifer type wood, and context 15, which contained non-conifer type wood.

The carbonized remains found in the cist and in the exterior backfill are similar in nature. There were no particular concentrations of carbonized remains in the cist, and charcoal fragments appeared to be randomly distributed across the floor. They included one sizeable lump (SF25), 2cm long, which may be residual from charcoal relating to earlier activity on the site. A carbonized heather family leaf and flowers, together with individual seeds of heath grass and ribwort plantain, provide further evidence for the burning of local vegetation. The uncarbonized wood fragments probably derive from the burial rite.

Soils and residues

A suite of analyses was carried out on samples of disturbed deposits in the cist, taken on a 20cm grid, along with samples from undisturbed burial deposits taken according to body area. The analyses are detailed in the following sections. Organic and bulk soils analyses of these samples sought to maximise information from the sediments, to identify if possible any materials placed with or on the body and to clarify the

post-depositional processes that had affected preservation of organic materials (see Keely et al, below; C Wilson, below).

In addition, hand-collected samples from three particular types of sediment were examined using various methods:

- *Sediments from the upper burial deposits:* The photographs taken before police intervention in the cist show concentrations of white material over the body's head, chest and lower legs (illus 2). These were recovered and retained according to the sampling grid. The photographs appear to show differences in these deposits – for example, what appears to be thick – although patchy – material corresponding to the woven material over the top of the head is noticeably more yellowish than that visible over the face, neck and chest. By the time excavation took place, these clear differences were no longer discernible due to the deposits' disturbance, although there were some differences in colour and texture that

were reflected in the different contexts identified.

- *The fragmentary remains of white matter from immediately around the body:* Fine white powdery material covered most of the bones, particularly the long bones that were removed by the police; this was examined by a palaeobotanist, Dr Jennifer Miller, who established that it was not fungal (J Miller pers comm). Discrete deposits of whitish material (context 23) were found lying directly on the pelvis and in the surrounding undisturbed burial matrix (context 19) (illus 7). However, not enough of this material survived from either context for organic residue analysis.
- *White crystalline deposit from the cist walls:* This deposit occurred as thin, undulating lines on the stone slabs forming the cist walls, and was sampled for analysis.

Six samples of white material from disturbed burial deposits were subjected to organic residue analysis (see Šoberl & Evershed, below), and

TABLE 5

Summary of the results of the organic residue analyses. FA refers to free fatty acids; MAG to monoacylglycerols; DAG to diacylglycerols; TAG to triacylglycerols; n.d. is none detected

<i>Bristol sample no</i>	<i>Context</i>	<i>Lipid concentration ($\mu\text{g/g}^{-1}$)</i>	<i>Lipids detected</i>	<i>Predominant commodity type</i>	<i>Description</i>
LNG 01	12	16.20	FA (16:0, 18:0), MAGs	potential contamination ?	Light brown clumps and fine dust
LNG 02	12	0.00	n.d.	n/a	Black/cream crumbs
LNG 03	14	306.57	FA (16:0, 18:0), TAGs	potential contamination ?	Off-white clump and dust
LNG 04	14	0.00	n.d.	n/a	Yellowish lumps with structure
LNG 05	15	12.26	FA (16:0, 18:0), TAGs	potential contamination ?	Creamy brown clumps and fibres
LNG 06	15	0.00	n.d.	n/a	Large off-white crumbs and clumps

a)

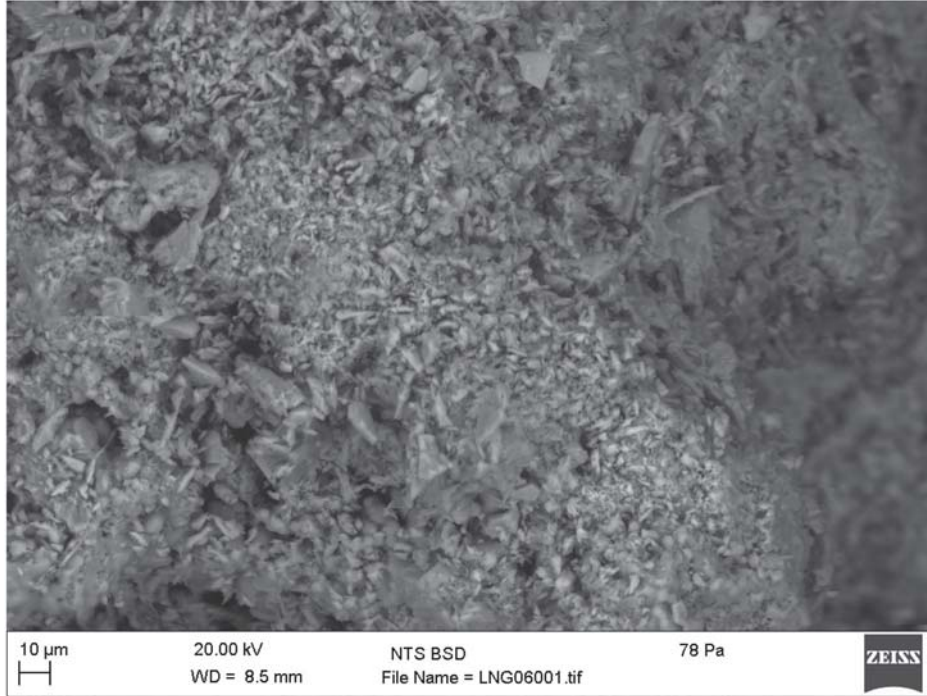

b)

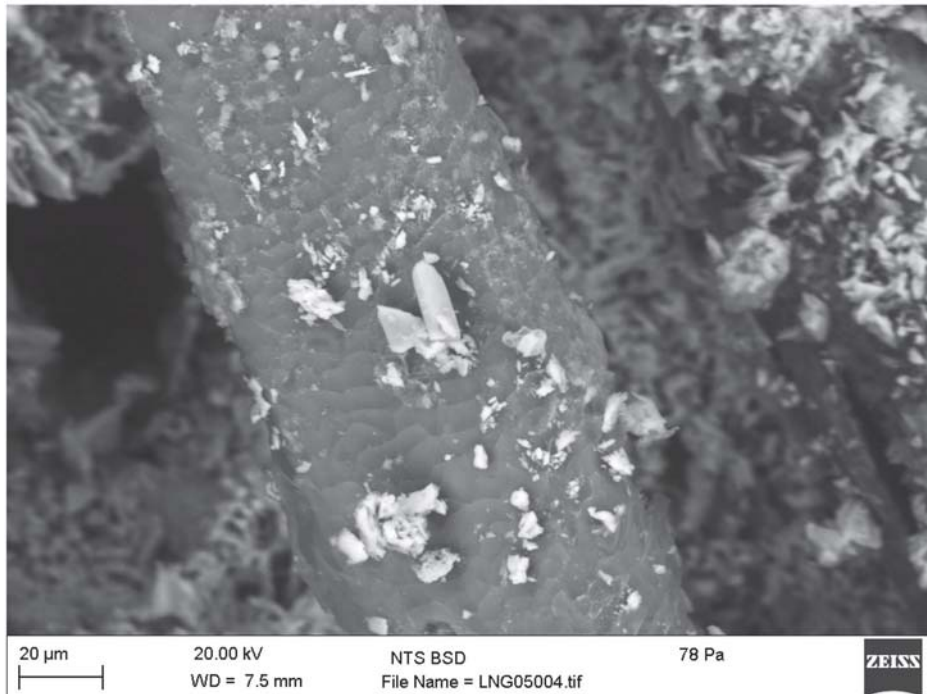

ILLUS 23 SEM-EDS backscatter images of the white, crumbly material from context 15: (a) shows crystalline structure of material; (b) shows hair fibres present

five of these deposits were also examined using SEM-EDS (C Wilson, below). A sample of the white crystalline deposit from the cist walls was analysed using X-ray diffraction (L Wilson, below).

The analyses sought to establish the nature and origin(s) of these white materials – specifically, whether they were by-products of decomposition, such as adipocere, or whether they derived from substances that were added to the burial as part of the rite, or whether superficially similar materials in fact had different origins.

Organic residue analysis

Lucija Šoberl and Richard P Evershed

Lipid analysis was carried out on six samples of white material – taken as discrete samples in the field and also extracted from bulk samples – to establish the presence or absence of organic residues that might derive from decomposition of the body or other materials. The analyses were performed using established protocols that are described in detail elsewhere (Evershed et al 1990; Charters et al 1993). The identification of individual compounds was based upon eluting order, comparing retention times to standards and comparing the mass spectra with known fragmentation patterns and NIST spectra library.

The six samples were held in vials and varied in colour (from yellowish to white) and granulation (from powdered to smaller concretions). Table 5 lists the concentration of lipids detected in

the samples, together with a brief summary of the types of lipids preserved and preliminary interpretations.

The samples were provisionally interpreted as remains of adipocere due to their association with the skeletal remains in the cist. Adipocere represents a post-mortem arrest of tissue and body fat decomposition with a final product that has a wax-like consistency and greyish-white colour. It is composed mainly of free saturated fatty acids and hydroxy-fatty acids. It can form in a variety of environments, both terrestrial and aquatic, but shows preferential formation at the presence of body fat, moisture, mildly alkaline pH, warm temperature, anaerobic conditions and presence of appropriate bacteria (Ubelaker & Zarenko 2010).

The Langwell Farm samples show the almost complete absence of preserved organic molecules. This has been confirmed by two independent analytical techniques – elemental analysis and organic residue analysis. The samples display very poor lipid preservation, with half of the analysed samples yielding significant lipid concentrations (that is, >5mg/g). Lipid concentrations in samples LNG 01, LNG 03 and LNG 05 are very low and the present compounds are uncharacteristic of archaeological lipid extracts. An almost complete absence of organic molecules was further confirmed with the elemental analysis, which showed a very low total carbon content ranging between 0.443% and 1.438% of the samples' weight (see Table 6).

TABLE 6
Summary of the CHN elemental analyses

<i>Bristol sample no</i>	<i>Context</i>	<i>Total N [%]</i>	<i>Total C [%]</i>	<i>Total H [%]</i>
LNG 01	12	0.128	0.508	0.004
LNG 03	14	0.249	1.438	2.113
LNG 04	14	0.114	0.443	2.684
LNG 05	15	0.156	0.837	2.623
LNG 06	15	0.187	1.034	2.690

TABLE 7
SEM-EDS results

Sample	Context	% Weight									
		C	O	P	S	Ca	Al	Si	Fe	N	
LNG 02	12	10.5	52.4	9.53	4.95	20.6	0.22	1.79			
LNG 03	14	22.6	50.0	5.47	5.55	13.0	0.50	2.00	0.72		
LNG 04	14	11.4	53.1	8.81	4.41	15.9	0.05	6.33			
LNG 05	15	13.1	54.0	8.37	6.03	16.65		1.86			
LNG 06	15	23.6	49.8	8.64	1.61	13.4	0.19	2.81			
LNG 05 fibres/hair	15	35.9	36.6	1.5	3.44	5.31		3.77		13.5	

SEM-EDS analysis of white residues

Clare Wilson

As organic analysis of samples of the crumbly white residue from the cist had proven inconclusive (see Šoberl & Evershed, above), five of the same samples were analysed using SEM-EDS with the aim of determining their inorganic chemistry. The samples analysed were from context 12 (LNG 02), context 14 (LNG 03 and 04) and context 15 (LNG 05 and 06).

As the analysis was performed on non-polished samples, all results have been normalised to 100%. Four point analyses were taken from across the surface of each sample and the mean of the results calculated.

The white residue in all five samples was shown to be highly crystalline (illus 23a). The chemistry is shown in Table 7.

The C/O ratio of all samples suggests they are carbonates. The high concentrations of calcium, phosphate and sulphur indicate these carbonates originate from the decay of the body rather than being naturally occurring soil minerals. The white residue, therefore, appears to be the product of bone recrystallisation producing carbonates and phosphates derived from bone apatite.

In sample LNG 05, context 15, fibres are visible running through some fragments of the white residue. Under the SEM these are clearly identifiable as hair fibres (illus 23b) with diameters ranging from 20–80µm. Although it is not possible to give a confident identification of animal species from SEM images, these fibres are not inconsistent with cattle hide (P Walton Rogers pers comm).

Crystalline deposit from the cist wall

Lyn Wilson

An undulating, white crystalline deposit was observed on the walls of the cist. A sample of this was subjected to X-ray diffraction analysis. The major mineral present in the sample was calcium carbonate (calcite), derived from bone. Minor amounts of quartz, feldspar and clay (illite) were also detected. These are normal components of rock weathering, commonly found in sediment.

The deposit appears to consist of calcite that had leached out of the bones during periods of waterlogging and flooding and remained as a residue on the walls when water levels dropped.

Bulk soils analysis

Clare Wilson

A suite of geochemical analysis was carried out on 16 soil samples from the disturbed and undisturbed deposits in the cist, in search of information on processes of decomposition and post-burial conditions in the cist. The analyses consisted of:

- Visual assessment using a low-power binocular microscope to assess texture, colour, basic mineralogy and the presence of coatings and cements, and to establish the likely value of further analyses;
- Soil pH to answer questions about the nature of preservation and loss of evidence;
- Total soil phosphate to test for a signature of the decomposition of the body;
- Loss-on-ignition to measure the proportion of organic matter in the soil as a pointer to the possible presence of decomposed organic residues from the body or other materials;

TABLE 8
Results of the laboratory analyses on the soils

Sample ID	Context	pH		Magnetic susceptibility	% Loss on ignition	% volume			Total P P mg/kg
		Water	CaCl ₂			Clay	Silt	Sand	
09	15	5.80	5.22	0003	7.8	4.2	62.0	33.8	1247
12	14	5.41	5.01	0010	1.8	2.5	40.4	57.1	6438
14	13	4.80	4.44	0009	1.3	2.1	36.9	61.0	116
15	17	5.63	5.10	0009	4.1	3.1	51.7	45.2	649
16	12	6.21	5.22	0008	3.6	2.2	37.9	60.0	1872
17	12	5.75	5.63	0007	4.0	1.4	25.4	73.2	2147
26	11	5.36	5.45	0009	2.4	3.4	52.9	43.7	1449
35	18	5.21	4.88	0010	1.5	2.7	44.3	53.0	884
37	16	6.07	6.09	0001	7.0	1.7	36.8	61.5	1280
46	22	5.57	4.93	0003	1.8	1.6	35.4	62.9	1341
50	22	5.81	5.37	0006	1.6	1.6	28.4	70.0	3013
51	19	5.94	5.46	0009	8.3	1.2	24.8	74.1	6277
52	19	6.27	5.65	0007	6.6	2.6	46.6	50.8	2998
54	19	6.05	5.70	0005	5.7	1.8	22.7	75.6	2731
55	22	5.94	5.42	0006	2.3	1.3	17.0	81.7	2181
56	19	5.93	5.41	0008	5.8	1.3	88.8	9.9	1946

TABLE 9
Bulk soil results according to context

<i>Context</i>	<i>Sample numbers</i>	<i>Roots/ charcoal</i>	<i>Mag sus.</i>	<i>% OM</i>	<i>pH</i>	<i>P mg/kg</i>	<i>% clay</i>	<i>% sand</i>	<i>Context description</i>
11	26	C	9	2.4	5.4	1449	3.4	43.7	Material laid with burial
12	16, 17	R, C	8, 7	3.6, 4	5.8, 6.2	1872, 2147	1.4, 2.2	60, 73.2	Organic rich burial matrix
13	14		9	1.3	4.8	116	2.1	61	Material laid with burial
14	12		10	1.8	5.4	6438	2.5	57.1	Material laid over burial on S
15	9	C	3	7.8	5.8	1247	4.2	33.8	Burial matrix with decayed bone
16	37		1	7.0	6.1	1280	1.7	61.5	Burial matrix with decayed bone
17	15	C	9	4.1	5.6	649	3.1	45.2	Organic rich burial matrix
18	35	R, C		1.5	5.2	884	2.7	53	Material laid with burial
19	51, 52, 54, 56	R, C	9, 7, 5, 8	8.3, 6.6, 5.7, 5.8	5.9, 6.3, 6.1, 5.9	6277, 2998, 2731, 1946	1.2, 2.6, 1.8, 1.3	74.1, 50.8, 75.6, 9.9	Stained burial matrix
22	46, 50, 55	R, C	3, 6, 6	1.8, 1.6, 2.3	5.6, 5.8, 5.9	1341, 3013, 2181	1.6, 1.6, 1.3	62.9, 70, 81.7	Stained subsoil

- Non-destructive micro-elemental analysis (SEM-EDX) to establish the nature of mineralised deposits, pigments and soil stains, as well as identify the presence of organic remains, and
- Magnetic susceptibility analysis to test for evidence of heating of the soil.

The soils in and around Langwell Farm are mapped by the Soil Survey of Scotland (1982) as peaty gleys and peaty podzols belonging to the Arkaig soil association. They are formed on stony till deposits derived from schists, gneisses, granulites and quartzites, principally of the Moine Series. The natural pH of these soils today would be expected to be extremely acidic, and hence bone and organic matter preservation in such soils could be expected to be poor. The location of the cist on a low rise but close to the River Oykel indicates that it may at times have been subject to groundwater influences.

Sub-samples taken from 16 samples from 10 contexts were air-dried and sieved to 2mm. Visual assessment of the soils established they were greyish brown and olive in colour. Samples that stood out as different were samples 46, 50 and 55 (context 22 from the stained sub-soil), which were generally coarser in texture than the others, and sample 56 (context 19, the greasy deposit from beneath the bones), which contained many bone fragments. A number of samples also contained white friable material. Evidence of biological disturbance was generally low, though root fragments were noted in samples 16, 35, 55 and 56 from contexts 12, 18, 19 and 22. Magnetic susceptibility measurements (Table 8) of between 1 and 10 (unit less) made during the visual examination indicated moderate enhancement at a level consistent with anthropogenically modified soils, but not of the order that would be expected from significant burnt soil residues. Magnetic susceptibility levels were also relatively consistent between samples, revealing no clear patterning according to the nature of the deposit or the presence of charcoal (Table 9), so the decision was made not to proceed with more detailed magnetic measurements.

The preservation of bone and organic remains is determined by both intrinsic and extrinsic

factors (Millard 1998; Smith et al 2007). Intrinsic factors include the nature of the bone itself (size, porosity, composition), while extrinsic factors include the burial environment, biological activity and chemical soil properties. Three potential pathways of bone degradation are possible: (1) chemical degradation of the organic fraction; (2) chemical degradation of the bone mineral, and (3) biodegradation (Kars et al 2004). Pathways 1 and 3 also influence the degradation of organic materials.

Biological factors of decomposition are perhaps the least well understood and the most difficult to assess. The only factor considered in this report is the presence of plant roots surviving in the soil samples. Roots can influence preservation through physical disturbance of remains, the gradual opening of access routes into the grave for other organisms, the localised secretion of plant acids and through priming effects, whereby readily decomposable fresh organic matter increases microbial activity – and in turn increases the rate of turnover of older, less digestible organic molecules. The presence of rootlets was particularly noted in contexts 12, 18, 19 and 22, representing almost the full range of contexts (burial matrices, material laid with the burial and stained subsoil) and suggesting there was no preferential rooting into organic-rich contexts. Root-mediated degradation, therefore, was likely to be highly localised and relate to rooting patterns and access points into the cist.

Bone and organic matter survival is generally promoted by poorly drained, neutral or alkaline and oxygen-poor soil conditions. The local soil conditions at Langwell Farm are likely to have been highly acidic (pH 3.5–4.5). However, with the exception of sample 14, context 13, the soil pH recorded in the cist was significantly higher than pH 4.5. The local geology is dominated by gneiss, schist and quartzite, which are acidic/felsic or intermediate in their nature, and hence soils formed on them under conditions of high rainfall and free drainage tend also to be naturally acidic. However, the very low pH of the soils in the area today is in part due to the accumulation of peat, which releases organic acids. The onset of blanket peat development is linked to excessive soil wetness and/or soil acidity. A radiocarbon

date from Area B at Langwell (see below) indicates that peat did not begin to form locally until 2535 ± 30 BP (800–540 cal BC). The cist was cut into a mineral soil (context 2) and capped by a mineral deposit (context 9). The depth of the cut into less heavily leached soil also suggests that the soil pH at the time of burial may have been higher than the modern surrounding soil acidity suggests.

Soil pH adjusts relatively rapidly and the pH of the subsoil at the time of burial is likely to have been between pH 4.5 and pH 6. The capping of the cist would have subsequently protected the burial environment from further leaching and acidification and, depending on the lateral movement of soil water locally, may have helped to protect against acidification from the organic acids of the peat. The pH range of the soils from the cist was between 4.8 and 6.3, or moderately acid and neutral, the result of alteration of the burial environment and the buffering of the soil acidity. In the relatively protected environment of the cist, this represents a movement towards quasi-equilibrium, more conducive to bone preservation than the local modern soils would suggest.

The loss-on-ignition values of around 1.3–2.4% in contexts not in direct contact with the body (contexts 11, 13 and 14) give a background value for organic matter in the soils derived largely from the root fragments. The organic content of the subsoil (context 22) below the burial matrix (context 19) was also low, suggesting limited vertical translocation of organic matter. The contexts with the highest loss-on-ignition values are those thought to contain quantities of decayed bone (contexts 15 and 16). Low temperature combustion was chosen for this analysis (400°C) because the mineral content of bone and bone recrystallisation products should be stable at such low temperatures (Person et al 1996). The loss in mass of these soil materials therefore suggests that these contexts do contain significant quantities of organic remains, more than was found in those deposits that clearly contained humic or organic remains (contexts 12 and 17). As the bone in these deposits appears to be strongly degraded, it is likely the organic bone components had already been lost. The source of this additional organic

matter is unclear. It is possible the white or creamy crumbly material may in fact have been organic in nature and this was lost following combustion, a possibility supported by the results of SEM-EDS analysis (see C Wilson, above).

The formation of adipocere has been observed under a range of soil and burial conditions. Forbes et al (2005b) suggest adipocere is most easily formed under moist, anaerobic soil conditions and is retarded in highly acidic or alkaline soils. However, adipocere can also form in free-draining sandy soils if they are moist (Forbes et al 2005a), and adipocere deposits have been found to be stable under fluctuating groundwater conditions, having formed in anaerobic saturated conditions following burial (Fiedler et al 2009).

Phosphorous (P) occurs in soils in oxidised phosphatic forms; it is released from the body and bone via decomposition and is mineralised by the actions of soil microbes. These inorganic phosphates are predominantly immobilised in the soil through sorption to clay, Fe and Al minerals. The clay content of the soils from the Langwell Farm cist varies, but is sufficient to bind with at least a significant proportion of the mineralised phosphate, and P concentrations are consistent with those from other grave sites (eg Crowther 1997). As would be expected, phosphorous concentrations were highest in those deposits (contexts 12, 15, 16 and 19) that were in direct contact with the body. Context 22 (directly beneath the body) and context 14 (partly overlying it) also show enhanced phosphorous levels, indicating the vertical movement of phosphorus in both directions. As these contexts contained low organic matter levels, the inference is that this movement has occurred with the phosphate in mineral form. However, the pattern does not suggest heavy leaching of the soils but more localised redistribution, consistent with occasional waterlogging from groundwater. An increase in soil pH associated with bone decomposition – and inferred from the elevated pH within the cist – could result in the release of P bound to Fe and Al minerals and its redistribution in the soil water before binding to clay minerals (Holliday & Gartner 2007).

Waterlogged conditions (particularly in deposits rich in organic matter) can rapidly become

anoxic and inhibit microbial decay processes. However, alternating wet and dry conditions are generally viewed as being particularly damaging, as the equilibria between the grave materials and the burial materials is constantly shifting, resulting in degradation (Hopkins 1998).

Without examining the soils in situ, the drainage conditions are harder to infer; both gley (poorly drained) and podzol (freely drained) soils are found locally. The soils locally contain a significant proportion of coarse (>0.06mm) grain sizes and the soil samples tend to have a greyish colouration, indicating anoxic or waterlogged conditions. However, the surrounding local soils into which the cist was cut were yellow and orange sands and gravels,

suggesting more freely draining conditions predominate. The topographic position of the site does allow for this apparent conflict through the influence of groundwaters. Occasional periods of waterlogging and anaerobism could help explain the conflicting soil colours as well as the movement of P into deposits above as well as below the body. If waterlogging occurred soon after burial, it would also have provided conditions conducive to adipocere formation.

No significant statistical correlations were found between the soil properties of pH, clay and loss-on-ignition – which relate to preservation conditions – and phosphate and magnetic susceptibility – which are indicators of anthropogenic influence and decomposition.

TABLE 10
Samples analysed and discussed in the report

<i>Sample ID</i>	<i>Context</i>	<i>Original sample no</i>	<i>Description and location</i>
01	16	37	Yellow-white crumbly deposit in chest area
02	12	16	Reddish-brown crumbly deposit across centre of cist
03	19	52	Undisturbed greasy black sediment under in situ bones, specifically abdominal area
04	15	9	Creamy white crumbly deposit in head area
05	17	15	Dark brown crumbly deposit west of head

TABLE 11
Elemental abundances in <200 mm soil fraction from Langwell Farm

<i>Sample no</i>	<i>Context</i>	<i>%N</i>	<i>%C</i>	<i>%H</i>	<i>%S</i>	<i>%O</i>
01	16	0.54	5.29	2.05	0.08	4.25
02	12	0.29	3.05	0.94	0.00	2.92
03	19	0.68	6.15	1.27	0.07	4.47
04	15	0.26	3.28	1.88	0.05	2.09
05	17	0.21	2.60	0.85	0.00	2.03

TABLE 12
Atomic elemental abundances and elemental ratios in <200µmm soil fraction from Langwell Farm

Sample no	Context	Atomic N	Atomic C	Atomic H	Atomic O	H/C	O/C	H/N	N/C
01	16	3.88	44.04	203.30	26.55	4.62	0.60	52.39	0.088
02	12	2.07	25.44	93.00	18.25	3.66	0.72	44.91	0.081
03	19	4.84	51.21	125.55	27.94	2.45	0.55	25.92	0.095
04	15	1.87	27.36	186.24	13.09	6.81	0.48	99.80	0.068
05	17	1.48	21.71	84.39	12.70	3.89	0.59	56.99	0.068

This suggests the anthropogenic influence and decomposition were independent of original soil conditions and that the burial environment in the cist, and subsequent pattern of preservation, was a function of the equilibria approached between the soil conditions and the decaying body.

In conclusion, the interpretation of burial conditions from those that exist today is always difficult, as many of the key environmental factors can be highly dynamic. However, based on examination of the deposits and what we know about soils and soil development in the area, we can suggest that the burial environment is likely to have been a little less detrimental to bone and organic matter preservation than the modern local soils in the area would indicate. Soil pH in the

mineral subsoils into which the cist was cut is likely to have been weakly acid to neutral and, although the sandy subsoils are relatively free-draining, groundwater influences as a result of the topographic position of the site may have resulted in anaerobic conditions during at least part of its history. Occasional episodes of waterlogging and anaerobism are indicated by the vertical movement of phosphate and the grey colouration of the soils. The high loss-on-ignition values for contexts 15 and 16 suggest these contain significant quantities of an organic material rather than mineral bone deposits.

TABLE 13
Relative responses for pyrolysis GC analysis of Langwell Farm soils

Sample ID	Context	Peak area/mV normalised to TOC
01	16	568
02	12	229
03	19	488
04	15	609
05	17	77

TABLE 14
Several R groups present in triacylglycerols

R =	Abbreviation	Carbon number: degree of unsaturation
Myristic	M	C14:0
Palmitic	P	C16:0
Palmitoleic	Po	C16:1
Margaric	Ma	C17:0
Heptadecenoic	Mo	C17:1
Stearic	S	C18:0
Oleic	O	C18:1
Linoleic	L	C18:2

TABLE 15
 Percentage TAG composition and total response for 09 and 11

<i>Sample</i>	<i>Context</i>	<i>PMMa*</i>	<i>MPP_{OH}* </i>	<i>OMP*</i>	<i>PPP</i>	<i>PPMa*</i>	<i>PMaP*</i>	<i>PPP_{OH}* </i>	<i>PPS*</i>	<i>PMa_{OH}P*</i>
01	16			5.2		1.3	3.4		71.4	
03	19	7.6	2.6	0.5	0.9	10.5	14.9	3.1		4.1
05	17			1.4		0.9	8.4		75.5	

<i>SMaP*</i>	<i>SPMa*</i>	<i>SMaP*</i>	<i>SMaP*</i>	<i>PS_{OH}P*</i>	<i>PPS_{OH}*+ PSP_{OH}* </i>	<i>SPO*</i>	<i>SPS</i>	<i>SPO_{OH}* </i>	<i>SPS_{OH}* </i>	<i>Total response (×10⁸)^μ</i>
	5.8		2.0			11.0				63.22
16.8	5.3			3.1	8.0		4.6	10.8	7.2	188.17
0.9	0.5	1.0	1.7			9.7				134.33

TABLE 16
Bulk percentage fatty acid composition of the TAGs

Sample	Context	M	P	Po	Ma	Mo	S	O	L	P/S ratio
01	16	1.7	58.7	0	4.1	0	30	5.4	0	2
05	17	0.5	61.6	0	4.5	0	29.8	3.7	0	2.1
03	19	3.6	48.5	1.9	18.4	1.4	16.4	6.3	3.6	3

Analysis of soil organic matter

B J Keely, M D Pickering and A P Pinder

A suite of analyses was carried out on soil organic matter in five of the samples from the cist interior that were also subjected to inorganic soils analysis (C Wilson, above), from deposits that lay around and beneath the body (see Table 10).

The analyses were carried out to test for signatures of the body and of any materials that were placed with it. They consisted of:

- Measurement of elements (carbon, hydrogen, oxygen, nitrogen and sulphur) and of total organic carbon (TOC) content in order to differentiate types of organic matter and identify the presence of proteinaceous organic matter and concentrations of specific organic residues;
- Gas chromatography (GC) (to screen samples) and gas chromatography mass spectrometry (GC-MS) (for more detailed analysis and identification) to separate and identify extractable organic residues, which can provide important indicators of the origins and preservation status of organic matter in the soil, including signatures from the body, material added to the body and materials placed in the grave;
- Liquid chromatography (LC) (to screen samples), liquid chromatography mass spectrometry (LC-MS) and high performance liquid chromatography (HPLC) (for more detailed analysis and identification) to separate and identify different extractable organic residues than those determined by GC-MS, including lipids and amino acids.

- Pyrolysis gas chromatography to assess the nature of the non-extractable organic matter in the soil, complementing the GC- and LC-based applications.

Elemental analysis established that the total organic carbon (TOC) contents (%C) of the Langwell Farm samples indicate an organic-rich soil, with three of the samples having very similar levels and two having appreciably higher TOC (01 and 03) (see Table 11). Percentage abundances were converted to atomic abundances for the computation of key element ratios (Table 12). The results of the other analyses are presented in Tables 13–17.

The sediments sampled from inside the cist contain appreciable levels of organic matter comprising a range of natural product-derived organic residues, including complex structures. The distributions provide evidence of background signatures from vegetation, together with material that is likely to originate from a decomposing body. The more complex components, including triacylglycerols (TAGs, or fats which comprise a glycerol moiety bonded to three fatty acid molecules) and most likely peptides, indicate the preservation of signatures that relate to the body and/or organic matter placed in the soil at the time of burial. The variations in the distributions indicate that these signatures, though challenging to interpret, may provide clues as to the nature of the remains which were placed in the burial environment. The most significant differences in organic matter content are apparent for sample 05 (context 17, in the upper head area), which shows higher lipid-derived contributions to the organic matter, and sample 03 (context 19, below the abdomen),

TABLE 17
Abundances of amino acids released on hydrolysis of soil samples from Langwell Farm, normalised to grams of total organic carbon (TOC). Asp = aspartic acid, Glu = glutamic acid, Hpro = hydroxyproline, Ser = serine, His = histidine, Gly = glycine, Thr = threonine, Arg = arginine, Ala = alanine, Pro = proline, Tyr = tyrosine, Val = valine, Met = methionine, Ile = isoleucine, Leu = leucine, Phe = phenylalanine, Lys = lysine. UCM = an unresolved complex mixture encompassing the components shaded in grey. A sum was taken of the abundances of the coeluting species

Sample	Amino acid abundance ($\mu\text{g/g TOC}$)														Totals			
	Asp	Glu	Hpro	Ser	His	Gly	Thr	Arg	Ala	Pro	Tyr	Val	Met	Ile		Leu	Phe	Lys
01	2.7	5.9	3.7	2.2	0.9	2.5	3.1	3.5	1.7	0.5	0.5	1.3		1.2	5.1	5.2	0.6	40.6
02	0.2	2.2	2.3	1.0	0.2	0.8	0.5	0.6	0.4	0.1		0.6		0.1	1.2	1.8		12.0
03	1.9	4.6	4.0	1.7	0.8	1.2		2.2	2.0	1.7	0.9	1.7		0.9	4.6	5.7	2.1	35.9
04														14.3	42.9	3.6		539.6
05	1.3	3.5	3.0	1.5	0.3	2.0		3.2	1.5	1.5	0.4	0.9		0.5	2.4	3.1	1.5	26.5

which shows the most marked difference in TAG distribution accompanied by considerably higher signatures of fatty acids, likely to be derived from the body decomposition.

Discussion of the soils and organic residue analyses

Analysis of sediments and residues from the cist returned varying results (see Table 18).

The bulk soils analysis established that anaerobic conditions had prevailed at least periodically, with episodes of waterlogging evident; this explains the preservation of some organic materials (C Wilson, above). It identified high organic content in disturbed deposits from the head and thoracic areas that derived from something other than bone, and high phosphorous but low organic content in those contexts that were in direct contact with the body. Rising and falling water levels in the cist are also evident in the white crystalline deposit on the cist walls, which X-ray diffraction established represent calcite that leached from the bones (L Wilson, above).

The analysis of organic matter in five samples (also subjected to inorganic soils analysis) from disturbed and undisturbed burial matrices found signatures deriving from plant matter in all contexts, and degradation products from animal fats or plant oils in deposits associated with the head and abdomen. It also identified signatures from the decomposition of the body, especially in the undisturbed burial matrix below the abdomen (Keely et al, above). However, organic residue analysis and elemental analysis of six separate samples returned quite different results, finding an almost complete absence of preserved organic molecules (Šoberl & Evershed, above). Examination through SEM-EDS of five of these samples found that the white material in contexts 12, 14 and 15 was the product of bone recrystallisation, or bone apatite, and that fibres were present around the head area (context 15). Small, discrete deposits of greasy white material found lying directly on and beside the in situ pelvis (context 23) could not be analysed, as the quantities were too small.

In conclusion, the periodic waterlogging of the cist created conditions conducive to the survival of wood, bone and fibres and possibly also to the

TABLE 18
Comparison of the results of the soils and organic residue analyses

<i>Contexts analysed</i>	<i>Analysis</i>	<i>Results</i>
6B: white concretion on cist wall 12: disturbed matrix, centre of cist 13: disturbed matrix, 14: disturbed upper deposit, SE corner 15: disturbed matrix, head area 16: disturbed matrix, chest area 17: disturbed matrix west of head area 18: grey clay silt, SE corner 19: undisturbed lower burial matrix 22: stained subsoil beneath burial	X-ray diffraction	Context 6B was calcium carbonate, leached from bones by waterlogging
	SEM-EDS	White material in contexts 12, 14 and 15 was product of bone recrystallisation producing carbonates and phosphates derived from bone apatite; context 15 also contained hair fibres
	Organic residue	Only trace amounts of lipids Almost complete absence of organic molecules High abundance of MAGs and TAGs possibly due to contamination
	Bulk soils	Little evidence of biological disturbance No significant burnt soil residues or magnetic patterning Rootlets in most contexts Moderately acid to neutral pHs Significant amounts of organic material indicated by LOI in 15 and 16, from source other than bone High phosphorous but low organic matter in contexts 12, 15, 16, 19 Preservation due to equilibria between soil conditions and decaying body through periodic waterlogging
Organic soils	Organic-rich soils High lipid-derived contributions to organic matter especially in context 17 (upper head area) Plant-derived matter in all contexts, especially 15, 16, 19 Degradation products of TAGs from animal fats or plant oils in contexts 17 and 19 Vegetal input evident in contexts 12, 17, 19 Increased bacterial activity evident in 19 (below abdomen), possibly from degradation of body tissues Amino acids from proteinaceous organic matter in all contexts, especially 15 (lower head area)	

formation of adipocere, although none could be definitively identified among the residues. More specific biochemical information appears to have been lost to complex post-depositional processes and events, including waterlogging, desiccation and disturbance.

THE STONE FEATURE IN AREA B

The peat stripping operation that revealed the cist also dislodged four large slabs in an area

about 5m to the south, which was investigated in a small trench (Area B, illus 1 and 4). Removing the overlying peat revealed a curvilinear stone feature (25) that extended north-eastward for 1.4m from the south edge of the trench, then turned to run north for a further 1.3m before disappearing into the north baulk (illus 24). Along most of its length it was built of large, subangular stones up to 0.4m across, lying in a diffuse line along the southern portion, but side by side along the northern stretch. The northernmost 0.5m of the feature comprised

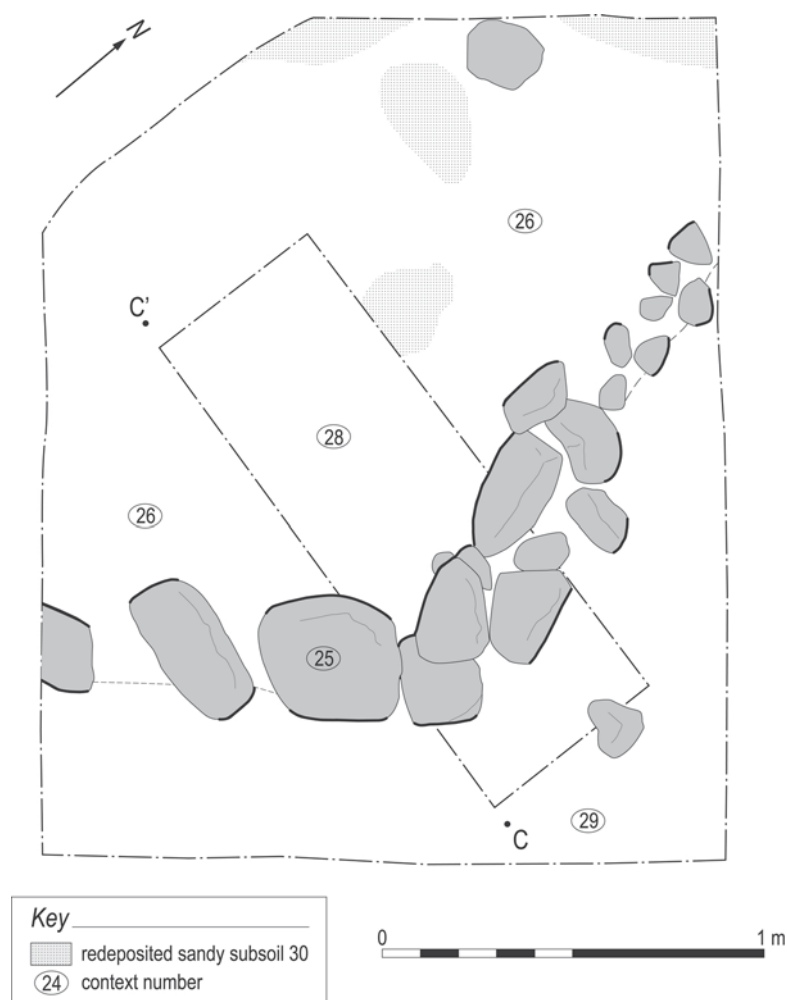

ILLUS 24 Plan of the stone feature in Area B

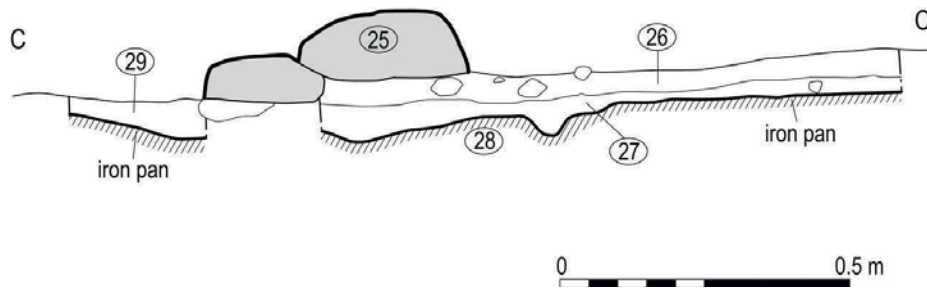

ILLUS 25 Section across the stone feature in Area B

much smaller, angular stones. It is not clear whether the slabs that the mechanical excavator displaced originally formed part of it and, if so, in what configuration.

The stone feature had been constructed on a ground surface represented by firm, light-brown, stony sandy silt (context 27), the base of which was iron-panned above the sandy gravel subsoil (illus 25). On the east, the feature rested on sticky black clay (context 29), the base of which was even more heavily iron-panned above the subsoil. The stone feature curved around the eastern end of the slight ridge that the cist occupies, and the early ground surface (27) beneath it sloped down to the east, towards an area that is now marshy.

A radiocarbon date from birch charcoal sealed beneath the stone feature shows that it was constructed after 1680–1510 cal BC (SUERC-32859 at 95.4% confidence). The presence of the peat and heavy iron pan to the east suggests that when it was built, it marked the transition from boggy to better-drained ground.

Where the feature was investigated in section, it proved originally to have stood two courses high. The upper course had slipped off to rest on a later, charcoal-flecked silty ground surface (context 26) that formed after it was built (illus 25). Several patches of yellow-orange coarse sand (context 30), interpreted as redeposited subsoil, lay on this later ground surface, sealed beneath the peat that began to form in the mid- first millennium BC (see below).

Carbonized plant remains

Susan Ramsay

A bulk sample from the old ground surface (context 27) that pre-dated the stone feature was analysed for the presence of any carbonized remains. Birch and heather-type charcoal, present in small quantities, may derive from the surface vegetation that existed before the feature was built. The charcoal evidence suggests that the local vegetation had been burned at least once, if not many times.

Peat profile

In August 2009, a bulk sample was taken from the basal peat overlying the natural clay in the vicinity of the cist (see illus 4 for location). Small fragments of birch charcoal were recovered from this sample, which probably derive from the burning of local vegetation either before or during initial peat formation.

RADIOCARBON DATES

The source samples for the 10 carbon¹⁴ dates were selected to provide a chronology for activity at the site and for the sequence and duration of the burial. In order to ensure a large enough sample of the cattle hide for AMS dating, all of the available fibres were sent to the Scottish Universities Environmental Research Centre in East Kilbride; specialist analysis of the material had established with confidence that the fibres all derived from a single animal (Walton Rogers, above).



ILLUS 26 Strath Oykel and the location of the cist, from the north



ILLUS 27 The cist during excavation, after removal of the contents

TABLE 19

AMS dates from the Langwell Farm cist, Area B and the profile through peat. All were calibrated using Oxcal v4.1

<i>Site</i>	<i>Sample</i>	<i>Material</i>	<i>Context</i>	<i>Description of Depositional context</i>	<i>Uncal</i>	<i>Calibrated 1 sigma (68.2%)</i>	<i>Calibrated 2 sigma (95.4%)</i>	δC^{13}
Langwell Farm, Strath Oykel	SUERC-32857	Charcoal: Pinus sylvestris	19	Residual charcoal incorporated in cist during burial	3860 ± 30	2460–2240 BC	2470–2200 BC	–26.7‰
	SUERC-32858	Charcoal: Pinus sylvestris	4	Residual charcoal incorporated in backfill during burial	3880 ± 30	2460–2300 BC	2470–2230 BC	–25.7‰
	SUERC-24680	Bone: Human right fibular shaft	Sk1	The burial	3690 ± 35	2140–2030 BC	2200–1960 BC	–21.1‰
	SUERC-33918	Bone: Human right ulna shaft	Sk1	The burial	3615 ± 35	2030–1930 BC	2130–1880 BC	–21.4‰
	SUERC-32865	Wood: Corylus	12	Contemporary with burial	3625 ± 30	2030–1945 BC	2130–1890 BC	–25.0‰
	SUERC-32348	Hair: Cattle hide	12+	Contemporary with burial	3610 ± 30	2025–1925 BC	2040–1880 BC	–25.4‰
	SUERC-32866	Wood: Corylus	12	Contemporary with burial	3595 ± 30	2020–1900 BC	2030–1880 BC	–27.4‰
	SUERC-32859	Charcoal: Betula	27	From ground surface sealed beneath stone feature 25	3310 ± 30	1625–1530 BC	1680–1510 BC	–26.3‰
	SUERC-32861	Monocot stems/ leaves	Peat monolith	From 90–91cm in peat monolith, test pit 2	2535 ± 30	800–590 BC	800–540 BC	–27.8‰
	SUERC-32860	Eriophorum	Peat monolith	From 50–51cm in peat monolith, test pit 2	1615 ± 30	400–540 AD	380–540 AD	–27.1‰

Two differing radiocarbon dates were obtained from the human bone (SUERC-24680 and SUERC-33918 above). Although there are discrepancies of 70 and 80 years at the earlier and later ends of the calibrated ranges respectively, the two dates overlap by 170 years and the difference between them is not statistically significant. The later date corresponds closely to the dates obtained from cattle hide and wood that were placed with the body, so the animal and woman both appear to have died around the same time that the wood was felled. However, thin section analysis did find evidence for arrested microbial attack on the bone (Booth, above). While this could be due to the waterlogged conditions in the cist, it could also suggest that the woman had been dead and her body prevented from decaying for a time before she was buried. If she had been dead for several months when burial took place, this would not be apparent in the calibrated ranges.

DISCUSSION OF THE RESULTS OF THE EXCAVATION AND POST-EXCAVATION INVESTIGATIONS

Olivia Lelong

The sequence of events

The disturbance of the cist at Langwell Farm by police and the removal of some of its contents limit comprehension of the burial rite to some extent. However, the excavation of what remained in situ and the specialist analyses of the contents have illuminated considerably what took place there in the third and second millennia BC, as well as conditions inside the cist and around it after the burial took place.

The first dated evidence derives from activity during the mid- to late third millennium BC, when at least one fire burned on or near this slight rise on low-lying ground by the River Oykel (illus 26). The Scots pine used for the fire was felled at some point between 2470 and 2200 cal BC. The large size of one of the dated pieces (SF25 from context 19) suggests that it burned close to the spot where the cist was later built and that the charcoal was not heavily trampled and dispersed in the intervening time. While it could indicate

sustained activity relating to settlement in the vicinity, it could equally derive from a single event such as a fire that was the focus of a camp, or one set to clear vegetation. Carbonized heathland and grassland plant remains in the cist fills do suggest that vegetation was cleared by burning, sometime before the cist was built, but the large, unrolled piece of charcoal points to a contained fire that burned more substantial pieces of wood.

Between 200 and 500 years later, in the late third or early second millennium BC, people chose this spot for a burial. They began by digging a large, oval pit and hauling slabs to it which had been quarried from an outcrop or river bed; the visible surfaces were weathered or water-worn. They excavated the sides of the pit to accommodate slabs of different heights and fitted them together to make a large box with a level top, pinning the corners with angular stones, crafting a solid and well-finished structure (illus 27). They backfilled the pit around it with some of the subsoil they had dug out. In digging the pit, they disturbed the spread of charcoal from the earlier fire(s); some of it fell into the cist and some became mixed with the backfill.

They took the body of a woman who had died in her late 20s, at some point between 2200 and 1880 cal BC, and wrapped it in the hide of a brown cow or bull, with the long edges of the hide together at her back so that it enclosed her like an envelope. She had been of gracile build, and a period of physiological stress during childhood, such as malnutrition or anaemia, had left fine lines in her teeth. Stable isotopes in her bones and teeth indicate that she probably grew up in eastern Sutherland and that she ate abundant animal protein (meat, eggs and dairy products) and perhaps some freshwater fish, but little or no ocean fish or shellfish.

She was placed in the cist on her left side in a flexed position, with her head to the north-west (illus 28). They may have bound her limbs to keep them in place inside the hide wrapping and, given the depth of the cist, they probably lowered her into it from above; her flexed body would have fitted snugly inside. They set small stones along the edges of the hide at her feet and back. A bark-bearing hazel stick at her knees may have been placed there as part of the burial

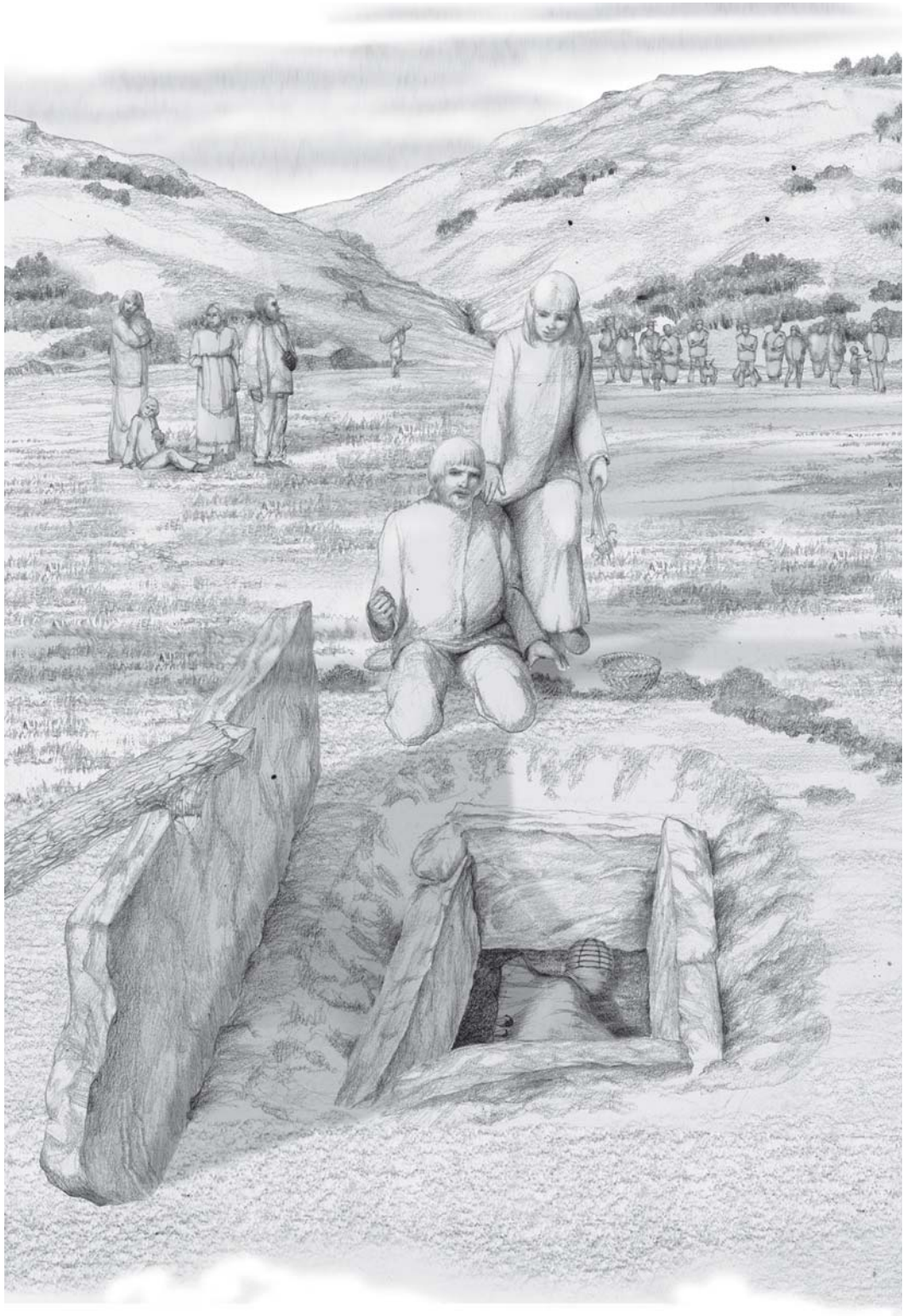

ILLUS 28 Reconstruction of the burial taking place, by David Hogg



ILLUS 29 Reconstruction of the burial, showing two possible interpretations of the woven material (based on Harris, this report). By David Hogg

assemblage, or perhaps it was the remains of a bier on which she was carried. They put one or more woven objects on or over the body. Two possible interpretations of the woven material that is visible in the photographs taken before police intervention (illus 2) are shown in illus 29; either version is plausible.

Thin-section analysis of the bone found evidence for arrested microbial attack. This could be due to subsequent waterlogged conditions in the cist, but the evidence is ambiguous and the possibility remains that the body was curated for a period after death, before burial. The mites found in the cattle hide may have been feeding on the beast when it was slaughtered, or they may have entered the cist on the bodies of burrowing rodents such as wood mice, although there was no direct evidence for rodent disturbance.

The people conducting the burial dragged a massive slab in place to cover the cist. It did not appear to have been trimmed to fit the cist and indeed was much larger than necessary to cover it. They sealed the cist with sand and gravel dug out from the alluvial subsoil; the evidence

could suggest they covered it with a cairn or composite barrow-cairn of soil and stones, which was eventually spread by ploughing and further truncated during peat stripping. The 9cm thick layer of sand and gravel recorded clinging to the cap slab had been scraped by the mechanical excavator, and it may originally have been much thicker. The ground was ploughed occasionally during the late 20th century (Mr J Hampton pers comm), although rarely, due to its stoniness, and the auger survey found a concentration of cobbles immediately around the cist (Becket & Miller 2009). Other barrows are known in the area, including one in a small, linked river valley at Corriemulzie Lodge (NMRS NH39NW 1), about 10km to the south-west, and another at Knock Dhu near Lairg, about 20km to the ENE (NMRS NC50NE 35). About 25 others are recorded around the firths of Moray, Beaully, Cromarty and Dornoch to the south-east and south of Langwell (information from NMRS).

The ground around the cist was poorly drained and occasionally flooded when the river was in spate. Within a few months, before much decay

could set into the contents, the ground water level rose and saturated them, inhibiting bacterial activity. Flooding was probably a regular occurrence during the following four millennia, until the land beside the river was improved and flood defences built during the later 19th century.

A few hundred years after the body was sealed inside the cist, there was more activity in the immediate vicinity, involving fire and a built feature. Charcoal that was scattered over the ground a few metres to the south derived from birch trees that were felled between 1680–1510 cal BC. At some point afterwards, someone built a curving stone feature around the south-east edge of the rise. It may originally have been a more substantial structure, which ploughing and peat-stripping would later disperse. It seemed to demarcate the higher, better drained ground to the west from low-lying ground to the east, where standing water eventually left minerals concreted onto the subsoil surface. The fire and the structure could relate to vegetation clearance and enclosure for agriculture and settlement, or to the later elaboration of a venerated site. By the mid-second millennium BC, the cist and putative barrow-cairn may have sat within a thoroughly managed and settled agricultural landscape – like the contemporary one revealed near Lairg, to the north-east (McCullagh & Tipping 1998; see below).

In the early to mid-first millennium BC, the local climate became wetter and cooler, and between 800–540 cal BC peat began to form on the floor of the river valley. These conditions continued at least until the mid-first millennium AD; a radiocarbon date shows that peat was still forming in AD 380–540. As the peat above this level was truncated, it is not clear how long it continued to accumulate after that.

Post-depositional formation processes

During the centuries and millennia after the cist was sealed, although water levels evidently fluctuated inside it, conditions remained wet enough that bacteria were prohibited from entirely consuming the organic materials. The wood was subjected to severe fungal attack, but this may have taken place after the land was drained in

recent times. The rising and falling water leached calcium carbonate out of the bones and left it as a crystalline residue on the cist walls, and also leached minerals from the sediments in the cist.

The distinctive white powdery substances, visible in pre-disturbance photographs (illus 2), occurred in the disturbed burial matrix and were found adhering to bones, were at first interpreted as products of decomposition of the body. Some differences are apparent in the photographs; for example, the white material over the putative woven cap looks distinctly more yellowish than that over the face. As reported above, analysis of the bulk soils indicated high organic content in those sediments in which it was most concentrated. The analysis of soil organic matter also found background signatures from vegetation, along with material that is likely to originate from the body, including higher signatures of fatty acids in the undisturbed burial matrix, although some of these may derive from organic material placed with it. Organic residue analysis of a separate set of samples of some of the same sediments returned a result of low organic content. However, SEM-EDX analysis established that the same samples were recrystallised bone apatite, and the sample from context 15 in the head area contained hair fibres which could be bovine or human. Although this sample showed only minute traces of organic material in the organic residue analysis, it may be that the fibres were not present in the very small sub-samples used in that method (C Wilson pers comm). These varying results could also mean that two or more materials of quite different character were so transformed and de-natured by post-depositional processes that they could no longer be differentiated, and the disturbance of the contents may have further blurred biochemical distinctions between deposits in different parts of the cist.

Apparently similar white material was found in a large cist inside a henge monument at Forteviot in Strathearn (Noble & Brophy 2011), but analysis has demonstrated different origins for it. The person buried in the Forteviot cist died between 2199–1977 cal BC, but almost nothing survived of the body, probably due to the acidity of the soils. He or she lay on a birch-bark mat

or bier and was accompanied by a large bunch of meadowsweet, animal hide, wooden vessels, a leather bag, a small knife or knife-dagger and a large bronze dagger with a gold pommel mount, perhaps in a sheepskin sheath (ibid). A hard white concretion found adhering to the lower walls of the cist proved to be calcium carbonate (Hall et al, in press), as at Langwell (L Wilson, above). What were described as greasy lumps of whitish material, apparently similar to material from Langwell, have been shown to be aggregates of fine gypsum crystals (Hall et al, in prep). The origin of the gypsum at Forteviot has not yet been established, but it is thought to derive from decomposition of the body rather than an external source (A Hall pers comm).

A cist excavated at Spinningdale, about 28km to the ESE of Langwell, held the flexed inhumation of a woman aged 35–50, who died 2051–1911 cal BC (Arabaolaza 2013). She was buried with a Food Vessel by her head, and she appeared to have lain on or been wrapped in sheepskin. White powdery material was noted on parts of her head, but it has not at the time of writing been subjected to scientific analysis.

Wrappings of power?

The cattle hide in which the woman's body was wrapped and the woven and wooden materials placed with her seem to evoke a special, exceptional burial. But it is worth asking: was it indeed unusual for its place and time, or is it simply a rare example of excellent preservation? If organic materials had not been preserved, it would have been an unremarkable cist containing a skeleton, of which many have been found across Scotland. Were burials with organic components – like the examples at Forteviot and Spinningdale mentioned above – in fact relatively common, even if the evidence rarely survives?

Hunter's (2000) social interpretation of the presence and character of artefacts in Early Bronze Age burials highlights the complexity and variety in burial practices and the likelihood that many contained organic components of which no trace remained. Of 192 burials on the Scottish mainland (a sample comprising about a quarter of the known burials at the time of publication),

38% were not accompanied by anything that had survived the processes of decay (ibid: 175). It may be that people were routinely buried with organic objects – or at least clothed – while some were also buried with more lasting objects like pots or ornaments.

Animal hides have been identified (definitely or tentatively) accompanying inhumations in at least 11 cists in Scotland (see McAdam 1982; Wilkin (2012) and Walton Rogers (above) discuss several other examples in Britain and Ireland. Those in Scotland have been found mainly in the east – four in Aberdeenshire, three in Fife, one each in Angus, Clackmannanshire and Moray, and now Langwell in Easter Ross – with a single example known from Argyll. Where age could be established, all were found with adults except for one cist at Broomend near Inverurie, where what was thought to be animal hide covered an adult and an infant together (Chalmers 1868). Most of the hides that could be identified are thought to be bovine. The hide was interpreted as covering the body in all the Aberdeenshire burials, as well as in an Early Bronze Age inhumation at Ingleby Barwick on Teesside (Walton Rogers, above).

In two cases, the hide was placed like a pillow: at Barns Farm in Fife, the head of a young man rested on animal hide (Watkins 1982: 49), and at Cuninghar in Clackmannanshire, a hairy substance (possibly stoat fur (MacAdam 1982: 127)) lay beneath the head of a flexed inhumation, along with a matted substance thought to be 'felted or unwoven cloth' (Robertson 1895: 194–5). The wool fibres identified from the cist at Spinningdale in eastern Sutherland lay beneath the left arm (Walton Rogers 2013). Organic materials such as leather, wood and meadowsweet have also been found in association with metal objects in elaborate graves, such as in the cist at Forteviot noted above (Noble & Brophy 2011).

Three other examples, all from Fife, combined animal skins with rare objects. A cist at Ashgrove contained a crouched inhumation accompanied by a Beaker, a flat bronze dagger in an animal skin sheath and a large piece of possible sphagnum moss (Henshall 1964). Another at Masterton contained almost no trace of the body but remnants of European bison or aurochs hide covered the floor, along with a jet necklace, bronze armlets

and a bronze dagger (Henshall 1963), and a cist at Rameldry Farm held the crouched inhumation of an old, arthritic man with a bronze dagger in a hide-lined scabbard, wearing a garment with six jet and lizardite buttons (Baker et al 2003). Woven coverings and other components have been found in Bronze Age Scottish burial contexts in the south-west (Dumfries and Galloway, Glasgow and Lanarkshire) and Orkney, as reviewed by Harris (above).

Another example worth noting from farther south, in Yorkshire, is that of Gristhorpe Man (Melton et al 2010; 2013). A man of prominent stature, who had eaten plenty of meat during his lifetime, was wrapped in animal hide that was fixed at the chest with a polished bone pin, and buried in a log coffin along with a bronze dagger and pommel, basketry and other artefacts. He died at some point between 2200–2020 cal BC (at 95% confidence) (Batt 2013: 92). The authors interpret the presence of the hide wrapping, dagger and other fine objects as indicating his high status, suggesting he was a ‘paramount chief born locally’ (Melton et al 2010: 811). They also suggest that burials in log-coffins (of which 75 Bronze Age examples are recorded in the United Kingdom) may have been reserved for people with symbolic associations with woodland or boats (ibid: 799).

As Walton Rogers (above) observes, the practice of burying Early Bronze Age bodies with animal hides (and other organic materials) was probably more common than the few known examples in Britain, Ireland and across northern Europe attest. People were using timber, hides, bone, horn and wool in everyday life, and it may not have seemed extraordinary to employ them in rituals relating to the dead. Taking into consideration the considerable evidence for variety in the composition of burials and the likelihood that organic materials were included much more often than their survival would suggest, the Langwell burial may not have been particularly unusual.

That said, this burial was composed with care, and those who created it chose to include certain things and leave out others that were sometimes being placed with the dead at the time, such as a decorated pot, a jet ornament or

a bronze object. Those decisions must have been laden with meaning. They would have arisen from the relationships between place and people, and the objects they placed with her may have been metaphors for the dead woman and her connections in life (see Brück 2004).

The cattle hide in which her body was wrapped may have symbolized the material resources that were vital to the community’s survival (cf Jones 1998), or it may have evoked much more. The rearing and tending of cattle would have shaped the rhythms of people’s days and seasons and the ways they moved around the valley or onto the hills. The slaughtering of cattle for meat, hide and horns would have released a range of resources for meals and objects such as garments, shoes, bags and tools, as well as wrappings for the dead. Wilkin (2012) has considered the contextual and historical relevance of animal remains in Late Neolithic and Early Bronze Age burials, noting that the ways they were treated in broader rituals extended beyond their value as economic assets, food for funeral feasts or simple symbols of the natural world. Placing animal remains with the dead may have evoked one of many references to particular events, agricultural practices, seasonal routines, myths and cosmological beliefs.

In pre-industrial societies, animals are often seen as embodying the powers of the natural world, and spirits of the dead are thought to take on the identities and powers of particular animals. Ritual specialists or shamans can call up these powers by wearing animal masks or wrapping themselves in animal skins, thereby taking on the identity of an animal (also see Morris 1998: 221–2). The more durable elements of animals, such as skin, hooves and claws, can represent the ongoing, regenerative nature of life, and Wilkin (2012) argues that their inclusion with burials was a means of placing the dead firmly within their own lineages.

Interpreting the burial rite at Langwell

Even though cist burials are relatively common, the corpus of known burials can hardly contain the scales of Bronze Age populations in Scotland that settlement patterns and environmental impacts imply. The cist is also an unusual form

of building; square and rectangular structures are almost unknown in Bronze Age contexts other than burial. So starting from the proposal that a cist burial is itself laden with unusual meaning, what more can be proposed about the Langwell burial? Whether it was unusual for its time and place or is simply unusual in *our* time and place, the remarkable survival of its organic components opens a rare window onto the funerary rite. The statements we can make with reasonable confidence about the sequence of events raise questions about other aspects of the rite which are more difficult to answer, not least because of the disturbance done before formal archaeological excavation could take place. Was the woman herself unusual in life or death? Was she part of an elite group, or was she selected from the wider population to perform some special purpose in life and/or in death? If she was a member of the elite, does the evidence for her occasional malnutrition point to a different kind of elite than one with which we are familiar? If her experience of food shortage in her childhood reflects a more humble origin, then does her apparently unusual burial indicate that she acquired a higher status despite an impoverished childhood?

The preservation of organics means that, not long after the cist was sealed and before bacteria had time to consume the contents, they were saturated with rising ground water. This might indicate that the burial took place in late winter or early spring, when the ground may have been more prone to flooding as mountain snows melted and the river level rose. The bone histology evidence suggests – but cannot prove – that the woman's body was curated for a time before burial; the evidence could support a scenario in which both intentional mummification and preservation through waterlogging took place. In that case, the people who buried her may have waited for a particular time to do it. This might have been for practical reasons: if she died during the winter, they may have waited for the ground to thaw and for daylight to lengthen for the considerable task of building the cist. It might also have been for cosmological ones: they may have waited for the cusp of spring, the equinox – an auspicious point at which formally to incorporate her spirit among the ancestors and a

clear signal of the regeneration that her powerful costume may have evoked.

Wrapping her body in cattle hide may have seemed a way of linking her spirit to the animal's and its inherent powers of regeneration, with which the life of the community would have been thoroughly entwined. The woven material around her head may have been a kind of mask or head-dress that, with the cattle hide, constituted a spiritually charged costume. This might indicate that she held a special role in the community, perhaps as a shamanic figure, one whose spirit could rightly assume the powers of the natural world.

There are other ways of interpreting the components of the burial, beginning with the cattle hide. It is easy, even intuitive, to imagine her body wrapped in a clean, sleek, tanned brown hide – a prized possession, the use of which would have conveyed her power or the wealth and status of those who interred her remains. Where evidence is available, it suggests that animal hides placed with Bronze Age burials had usually been processed. (I am grateful to Alison Sheridan for outlining the arguments and several examples in support of this, as set out below.) It has been suggested that the animal hide wrapped around Gristhorpe Man survived because it had been treated before burial (Melton et al 2010; 2013). Fragments of hide from cists at Forteviot (Noble & Brophy 2011) and Broomend of Crichtie (Chalmers 1868) appear to have been processed or at least scraped. Where hides have been found in cists and graves, there is no evidence for their having left traces of fat or blood (although in many cases sampling strategies and analytical techniques were not employed to test for this, especially in early excavations).

In terms of symbolism, a processed hide would also seem more in keeping with other metaphors often employed in Bronze Age burial rites. Body positions evoke sleep, and processed hides may have been used as high-status bed coverings in life and transferred to the grave to fulfil the same purpose. The addition to some graves of joints of meat, fire-making equipment and vessels that could have held food and drink further supports the idea that burials were often seen as facilitating transitions to the afterlife.

The burial at Langwell, however, may have been different. The presence of mites in the hide fibres seems to preclude its having been processed; if the hide had been stripped from the animal and cleaned, they would have dropped off (Anne Baker pers comm). If, however, the woman's body was wrapped in the warm, raw, bloody skin of a freshly killed beast that was sacrificed for the purpose – with the rest of the animal perhaps eaten in a funerary feast – this would explain their presence. It does remain possible that the mites entered the cist on burrowing rodents, but there was no evidence for this (such as rodent bones or fur) and to put much weight on that possibility would seem like special pleading. If the hide were in a raw state, this may have conveyed a different kind of symbolic power that drew on the animal's life force.

To explore another possibility, rather than expressing privilege, the cist may have been designed to contain something: the decomposing body, losing its integrity in spite of attempts at curation; something more dangerous, such as a disease, or the remains of someone who had violated taboos and was contaminated socially or spiritually. The leaving of a body (or parts and combinations of different bodies together) in solid stone boxes may at certain times have been an attempt to seal away something considered dangerous to society (MacGregor 2007: 234), even if at other times it conveyed high status and respect.

Langwell in context

The River Oykel flows eastward through a narrow glen until it enters a small gorge that cuts through the Torr a' Chorcain, the east/west ridge overlooking the burial site. The gorge opens onto flat land beside the cist that is often flooded by the Oykel in spate. The slight rise in which the cist was built does not now offer much protection from flood water, but in the past, when the river burst its banks, it may have been one of the few more reliably drier places on the valley floor.

The burial's geographical position may be relevant to understanding its significance to the community that composed it. It sits in the middle of the northern part of the Scottish land mass,

slightly to the east of the watershed between east and west coasts. Strath Oykel runs from the Dornoch Firth on the east coast to join several smaller valleys that lead to the deeply indented west coast; the modern Highland roads follow these same corridors. The distribution of early prehistoric monuments at either end suggests that this was an important cross-country route throughout earlier prehistory.

There is a striking concentration of 17 chambered cairns around the valley's western end and another cluster at the eastern end of the valley, around the Dornoch Firth (illus 5). Noble (2007: 66) highlights the way that Neolithic monument complexes in Scotland often sit along 'trans-peninsular routes' – natural corridors along river valleys that would have let travellers avoid risky sea journeys – with particular reference to complexes such as Kilmartin in Argyll and Stenness-Brodgar in Orkney. The clusters of chambered cairns at either end of Strath Oykel can be interpreted in a similar way. In linking the east and west coasts, the valley provided an alternative route to the long and dangerous circumnavigation of the northern end of the land mass, through the Pentland Firth and around Cape Wrath. It would have been a well-known and well-travelled route for several thousand years by the time of the burial at Langwell, one used first by herds of migratory animals and the groups of hunters that followed them.

When the ceremonial monuments at either end of the valley began to be built, from around the middle of the fourth millennium BC, they would have marked its entrances as significant junctions in the landscape. As Noble argues, complexes like these were not simply built for and by local groups for their own purposes; instead, they were 'created through the evolving and growing interaction between regional communities' (2007: 71–2). The clusters of chambered cairns would have been both products and symbols of the relationships between dispersed groups of people living along Strath Oykel, in adjacent valleys and on nearby coasts (also see Edmonds 1999: 81). People would have sometimes made journeys to the cairn complexes for ceremonial purposes, but often too as part of their seasonal or annual routines – to move stock to summer grazings, for

example, or to trade animals or objects, or for social contact and arranging matches.

The river valleys continued to be vital arteries through the land mass, and up to 1,500 years later, when the cist was built at Langwell, farming communities were living in clusters around the chambered cairns in northern Scotland; their remains are known especially near Lairg and at the eastern end of Strath Oykel (illus 5). The extensive programme of pollen and soil analysis carried out along with archaeological investigation near Lairg (McCullagh & Tipping 1998) established that by about 2500 BC the landscape there was thoroughly settled and given over to farming, with agriculture on the fragile soils viable through a carefully maintained regime of deep ploughing and intensive manuring (McCullagh 2011: 153–4). Communities living in Strath Oykel would have sustained themselves within a similar environment.

Evidence from chambered cairns such as The Ord North at Lairg (Sharples 1981) and the Clava Cairns to the south-east (Bradley 2000), on the far side of the Moray Firth, shows that these monuments played an active role in the lives of people in the Early Bronze Age with, for example, the insertion of burials and material culture into the cairns. This is not to suggest there was continuity of meaning or use from their original construction; rather, later generations reworked the meanings of the ancient monuments for their own needs, and continued to treat them as special focal points in the landscape and on their journeys through it. The distribution of cist burials in the east of the region (illus 6) further suggests that certain areas of the landscape continued to hold significance.

Changes in burial practice suggest that different belief systems were taking hold in different areas in the Early Bronze Age too. From about 2400 BC, those living around the Moray Firth began placing the dead in short cists, usually accompanied by Beakers, and they may have shared certain belief systems and cultural practices with other groups in eastern Scotland, England and Continental Europe (Wilkin 2010; Wilkin et al 2009). From about 2200 BC, people living over a wider area, including northern Scotland, began to adopt a broader and more mixed range of funerary practices. They sometimes placed food vessels in cists with bodies

and also rare or imported materials like bronze and jet or cannel coal, crafted with specialist skill into daggers and ornaments. This was especially the case in the Moray Firth region, where there are 18 known burials with jet or jet-like ornaments and eight with bronze daggers (Needham 2004; Wilkin 2010: 9).

These more eclectic approaches to burial took hold as tin-bronze metalworking was being adopted. The Moray Firth region lies at the end of a key cross-country route along the Great Glen, which links the east and west coasts of Scotland. It may have been a conduit for copper imported from Ireland for use in bronze metalworking, for special artefacts and also for less tangible things like beliefs and stories (Bray & Pollard 2012). The Migdale hoard, found about 25km to the south-east of Langwell on the north side of the Dornoch Firth, illustrates this flow of objects and ideas through the area (Sheridan 2002). It contained an axehead, jewellery and dress accessories that reflect fashions in central and northern Europe between 2250 and 1950 BC, the same calibrated time span as the Langwell burial. Objects like these may have been worn as talismans and been thought to have magical properties inherent in their materials; to touch, wear or be buried with them may have been to assume the protection and power of the objects (ibid).

The woman buried at Langwell was accompanied by no decorated pot, ornaments, weapons or tools that had required hard-won materials or special skills to make – at least, none made of non-organic materials – but the constituents of her burial may have been considered just as powerful. With respect to the corpus of burials in the Moray Firth region, she was in the minority in terms of her sex and slightly older than the average; about 30% of the Early Bronze Age burials in the region were of women and about 70% of these were in their early to mid-20s when they died (Wilkin 2010, based on data from a recent assessment by Dr Meg Hutchison for the Beakers and Bodies Project, University of Aberdeen). The position on her left side with her head to the north-west diverged from conventions in Beaker burials in north-east Scotland, where women were usually laid on their right sides with their heads to the west or south-west and a line

of sight to the south (Shepherd 1989; 2012: 263). Comparing Langwell with contemporary burials to the west and north is more problematic, as the dataset here is less well studied.

As noted above, the burial at Langwell was positioned midway along a valley linking east and west coasts, but its constituents and body position do not particularly resonate with funerary practices that were current to the east and south-east. Perhaps the people who created the burial were looking in another direction, sharing ideas and beliefs with communities in valleys to the north, along the west coast or in the Hebrides. Maybe their views were local concoctions.

CONCLUSION

The slight knoll on the valley floor at Langwell would have been a spot well known to people for one reason or another as they moved along Strath Oykel. It may have been known as an old hunting stance; as a dry, firm stopover for those driving cattle along the valley or to the uplands; as a point at which homage should be made to ancestral spirits during journeys to ancient ceremonial complexes, or as lying close to an excellent salmon-fishing spot (as it does today). It may have held several layers of meaning that had accumulated over generations of events, relationships and shared myths; it may have been a focus for occasional ceremonies that involved fires.

When it was chosen around the end of the second millennium BC for the burial of a woman in a substantial stone cist, dressed in symbolically charged materials drawn from animals and forests and perhaps sealed under a cairn or barrow-cairn, this implanted the place with yet another meaning. As far as we know, the materials used were entirely local, as was the woman: the cow one of the community's herds, the wood cut from a nearby forest. The rites used were a way of expressing a particular identity for her. They may have confirmed her links to the ancestral past, to the valley and its river and the powers inherent in the natural world, things that would give rise to the community's ongoing renewal.

ACKNOWLEDGEMENTS

The project was funded and monitored by Historic Scotland. The excavation was carried out with the assistance and osteological expertise of Iraia Arabaolaza. The principal author is especially grateful to Jonathan and Sarah Hampton, owners of Langwell Farm, for providing on-site shelter for the February 2009 excavation team, assistance on site and general support and encouragement then and since, and to Dr Alan Leslie of Northlight Heritage and Roderick McCullagh of Historic Scotland for their support and advice. Dr Anne Baker of the Natural History Museum kindly identified the mites and Paul Buckland provided further information on their habitats and habits. Dr John Clark, consultant forensic pathologist at the School of Medicine, and Dr Stuart Macdonald, senior lecturer in the School of Life Sciences, both at the University of Glasgow, generously lent their time and knowledge of decomposition processes in forensic contexts. Kenneth Brophy, Gordon Noble and Alan Hall shared useful information about the Forteviot cist, and Neil Wilkin was generous with his own research and background information. Earlier drafts of this paper were much improved by comments from Alan Leslie, Roderick McCullagh, Gavin MacGregor, Gordon Noble, Alison Sheridan and Neil Wilkin. Ingrid Shearer prepared the illustrations for publication; David Hogg created the reconstruction drawings (illus 28 and 29), and the photographs in illus 2, 20 and 21 were taken by John White. Thanks also to Anne Coombs, Lynn Fraser, Cait McCullagh, Allan Mackenzie and John and Trina Wombell of North of Scotland Archaeology Society for their assistance during the August 2009 fieldwork.

BIBLIOGRAPHY

- Adovasio, J M 2010 *Basketry Technology: A Guide to Identification and Analysis, Updated Edition*. Walnut Creek, Calif: Left Coast Press.
- Allen, M J, Gardiner, J & Sheridan, A (eds) 2012 *Is there a British Chalcolithic? People, place and polity in the later 3rd millennium*. Oxford & Oakville: Oxbow Books, Prehistoric Society Research Paper No 4.
- Appleyard, H M 1978 *Guide to the Identification of Animal Fibres*. Leeds: WIRA.

- Arabaolaza, I 2013 'ARO5: Spinning the yarn: a cist at Keas Cottage, Spinningdale,' GUARD Archaeology Ltd, http://www.archaeologyreportsonline.com/PDF/ARO5_Keas_Cottage.pdf.
- Aufderheide, A C 2003 *The Scientific Study of Mummies*. Cambridge: Cambridge University Press.
- Baker, L, Sheridan, J A & Cowie, T 2003 'An Early Bronze Age "dagger grave" from Rameldry Farm, near Kingskettle, Fife', *Proc Soc Antiq Scot* 133: 85–123.
- Batt, C 2013 'The Scientific Dating Evidence', in Melton et al (2013): 88–93.
- Becket, A & Miller, J J 2009 *Langwell Farm, Strath Oykel Auger Survey and Cist Reinstatement: Data Structure Report*. GUARD Report 2875.
- Bell, L S, Skinner, M F & Jones, S J 1996 'The speed of *post mortem* change to the human skeleton and its taphonomic significance', *Forensic Science International* 82: 129–40.
- Bender Jørgensen, L & Walton, P n.d. *A Textile Fragment and Animal Hair from Skipwith Common, Yorkshire*. Unpublished Textile Research Report on behalf of the Yorkshire Museum.
- Bradley, R 2000 *The Good Stones: A new investigation of the Clava Cairns*. Edinburgh: Society of Antiquaries of Scotland.
- Bradley, R 2011 *Stages and Screens: An investigation of four henge monuments in northern and north-eastern Scotland*. Edinburgh: Society of Antiquaries of Scotland.
- Bray, P J & Pollard, A M 2012 'A new interpretative approach to the chemistry of copper-alloy objects: source, recycling and technology', *Antiquity* 86 (333): 853–67.
- Brickley, M & McKinley, J I 2004 *Guidelines to the Standards for Recording Human Remains*. Reading: BABAO/Institute of Field Archaeologists.
- Broholm, H C & Hald, M 1940 *Costumes of the Bronze Age in Denmark*. Copenhagen: Nyt Nordisk Forlag (Busck).
- Brothwell, D & Bourke, J B 1995 'The human remains from Lindow Moss', in Turner, R C & Scaife, R G (eds) *Bog Bodies: New Discoveries and New Perspectives*, 52–8. London: British Museum Press.
- Brück, J 2004 'Early Bronze Age burial practices in Scotland and beyond: Differences and similarities', in Shepherd, I A G & Barclay, G (eds) *Scotland in Ancient Europe*, 179–88. Edinburgh: Society of Antiquaries of Scotland.
- Chalmers, J H 1868 'Notice of the discovery of a stone kist at Broomend, near Inverurie, Aberdeenshire', *Proc Soc Antiq Scot* 1 (1866–68): 110–14.
- Charters, S, Evershed, R P, Goad, L J, Leyden, A, Blinkhorn, P W & Denham, V 1993 'Quantification and distribution of lipid in archaeological ceramics: Implications for sampling potsherds for organic residue analysis and the classification of vessel use', *Archaeometry* 35: 211–23.
- Child, A M 1995 'Microbial taphonomy of archaeological bone', *Studies in Conservation* 40(1): 19–30.
- Crawford, B 2000 'Medieval Strathnaver', in Baldwin, J R (ed) *The Province of Strathnaver*, 1–12. Edinburgh: The Scottish Society for Northern Studies.
- Crowther, J 1997 'Soil phosphate surveys: Critical approaches to sampling, analysis and interpretation', *Archaeological Prospection* 4: 93–102.
- Darling, W C, Bath, A H & Talbot, J C 2003 'The O & H stable isotopic composition of fresh waters in the British Isles: 2, Surface waters and groundwater', *Hydrology and Earth System Sciences* 7(2): 183–95.
- Dent, B B, Forbes, S L & Stuart, B H 2004 'Review of human decomposition processes in soil', *Environmental Geology* 45: 576–85.
- Duffy, P 2006 'Excavation of a Bronze Age wicker container, Gearraidh na h'Aibhne, Isle of Lewis', *Scottish Archaeological Internet Reports* 19.
- Edmonds, M 1999 *Ancestral Geographies: Landscape, Monuments and Memory*. London: Routledge.
- Emery, I 1966 *The Primary Structures of Fabrics: An Illustrated Classification*. Washington, DC: The Textile Museum.

- Evans, J A, Montgomery, J, Wildman, G & Boulton, N 2010 'Spatial variations in biosphere Sr-87/Sr-86 in Britain', *Journal of the Geological Society* 167: 1–4.
- Evershed, R P, Heron, C & Goad, L J 1990 'Analysis of organic residues of archaeological origin by high-temperature gas-chromatography and gas-chromatography mass-spectrometry', *Analyst* 115: 1339–42.
- Fiedler, S & Graw, M 2003 'Decomposition of buried corpses, with special reference to the formation of adipocere', *Naturwissenschaft* 90: 291–300.
- Fiedler, S, Buegger, F, Klaubert, B, Zipp, K, Dohrmann, R, Witteyer, M, Zarei, M & Graw, M 2009 'Adipocere withstands 1,600 years of fluctuating groundwater levels in soil', *Journal of Archaeological Science* 36: 1328–33.
- Fitzpatrick, A & Harding, P 2011 'An evaluation of the henge monument at Loch Migdale, Sutherland', in Bradley, R, *Stages and Screens: An investigation of four henge monuments in northern and north-eastern Scotland*, 141–7. Edinburgh: Society of Antiquaries of Scotland.
- Forbes, S L, Stuart, B H & Dent, B B 2002 'The identification of adipocere in grave soils', *Forensic Science International* 127: 225–30.
- Forbes, S L, Dent, B B & Stuart, B H 2005a 'The effect of soil type on adipocere formation', *Forensic Science International* 154: 35–43.
- Forbes, S L, Stuart, B H & Dent, B B 2005b 'The effect of burial environment on adipocere formation', *Forensic Science International* 154: 24–34.
- Galloway, A, Birkby, W H, Jones, A M, Henry, T E & Parks, B O 1989 'Decay rates of human remains in an arid environment', *Journal of Forensic Science* 34(3): 607–16.
- Garland, A N 1987 'A Histological Study of Archaeological Bone Decomposition', in Boddington, A Garland, A N & Janaway, R C (eds) *Death, Decay and Reconstruction: Approaches to Archaeology and Forensic Science*, 109–26. Manchester: Manchester University Press.
- Gilchrist, R & Sloane, B 2005 *Requiem: The Monastic Cemetery in Britain*. London: MoLAS.
- Gleba, M & Nikolova, A 2009 'Fabric remains from Sugokleya (Ukraine)', *Archaeological Textile Newsletter* 48: 7–9.
- Gordon, C C & Buikstra, J E 1981 'Soil pH, Bone Preservation, and Sampling Bias at Mortuary Sites', *American Antiquity* 46(3): 566–71.
- Griffiths, D A 1960 'Some field habitats of mites of stored food products', *Annals of Applied Biology* 48: 134–44.
- Hackett, C J 1981 'Microscopical focal destruction (tunnels) in exhumed human bones', *Medicine, Science and the Law* 21(4): 243–66.
- Hald, M 1980 *Ancient Danish Textiles from Bogs and Burials: A Comparative Study of Costume and Iron Age Textiles*. Archaeological-Historical Series 21. Copenhagen: The National Museum of Denmark.
- Hall, A J, Wilson, L & Young, M E in press 'The case for reprecipitation of human bone as an event, in a Bronze Age cist burial, Scotland', *Proceedings of the 38th International Symposium on Archaeometry*. Tampa, Florida.
- Hall, A J, Boyce, A J, Brophy, K, Wilson, L, Young, M, Noble, G, Poller, T & Sanderson, D in prep 'Gypsum that resembled adipocere from a Bronze Age cist burial, Scotland'.
- Hanna, J, Bouwman, A S, Brown, K A, Parker Pearson, M & Brown, T A 2012 'Ancient DNA typing shows that a Bronze Age mummy is a composite of different skeletons', *Journal of Archaeological Science* 39: 2774–9.
- Hanson, D B & Buikstra, J E 1987 'Histomorphological alteration in buried human bone from the Lower Illinois Valley: Implications for palaeodietary research', *Journal of Archaeological Science* 14: 549–63.
- Harris, S M & Gleba, M in press 'Bronze Age moss fibre garments from Scotland – the jury's out', *Archaeological Textiles Review* 57.
- Hedges, R E M, Millard, A R & Pike, A W G 1995 'Measurements and relationships of diagenetic alteration of bone from three archaeological sites', *Journal of Archaeological Science* 22: 201–9.

- Henshall, A S 1950 'Textiles and Weaving Appliances in Prehistoric Britain', *Proceedings of the Prehistoric Society* 16: 130–62.
- Henshall, A S 1963 'A Bronze Age Cist Burial at Masterton, Pitreavie, Fife', *Proc Soc Antiq Scot* 96: 145–54.
- Henshall, A S 1964 'A dagger-grave and other cist burials at Ashgrove, Methilhill, Fife', *Proc Soc Antiq Scot* 97: 166–79.
- Hess, M W, Klima, G, Pfaller, K, Künzel, K H & Gaber, O 1998 'Histological investigations on the Tyrolean ice man', *American Journal of Physical Anthropology* 106: 521–32.
- Hillson, S 1996 *Dental Anthropology*. Cambridge: Cambridge University Press.
- Historic Scotland 1997 *The Treatment of Human Remains in Archaeology*. Edinburgh: Historic Scotland Operational Policy Paper 5.
- Holliday, V T & Gartner, W G 2007 'Methods of soil P analysis in archaeology', *Journal of Archaeological Science* 34: 301–33.
- Hollund, H, Jans, M, Collins, M & Kars, H 2010 'Various experiments to compare the FTIR-KBr and FTIR-ATR method for investigating bone diagenesis.' Unpublished raw data.
- Hollund, H I, Jans, M M E, Collins, M J, Kars, H, Joosten, I & Kars, S M 2011 'What happened here? Bone histology as a tool in decoding the postmortem histories of archaeological bone from Castricum, The Netherlands', *International Journal of Osteoarchaeology: Special Issue Paper 2011*.
- Hopkins, D 1998 'The biology of the burial environment', in Corfield, M, Hinton, P, Nixon, T & Pollard, M (eds) *Preserving archaeological remains in situ: Proceedings of the PARIS conferences 1st–3rd April 1996*, 73–85. London: Museum of London Archaeology Service.
- Hunter, F 2000 'Excavation of an Early Bronze Age cemetery and other sites at West Water Reservoir, West Linton, Scottish Borders', *Proc Soc Antiq Scot* 130: 115–82.
- Jans, M M E, Nielsen-Marsh, C M, Smith, C I, Collins, M J & Kars, H 2004 'Characterisation of microbial attack on archaeological bone', *Journal of Archaeological Science* 31: 87–95.
- Jay, M & Richards, M P 2006 'Diet in the Iron Age cemetery population at Wetwang Slack, East Yorkshire, UK: Carbon and nitrogen stable isotope evidence', *Journal of Archaeological Science* 33(5): 653–62.
- Jay, M, Parker Pearson, M, Richards, M, Nehlich, O, Montgomery, J, Chamberlain, A & Sheridan, A 2012 'The Beaker People Project: an interim report on the progress of the isotopic analysis of the organic skeletal material', in Allen, Gardiner & Sheridan (eds): 226–36.
- Jones, A 1998 'Where Eagles Dare: Landscape, Animals and the Neolithic of Orkney', *Journal of Material Culture* 3(3): 301–24.
- Kars, H, Collins, M, Jans, M, Nord, A, Arthur, P & Kars, E 2004 'Bone as an indicator in the in-situ degradation of archaeological heritage. Two examples: Apigliano, Italy, and Aartswoud, the Netherlands', in Nixon, T (ed) *Preserving archaeological remains in situ. Proceedings of the PARIS conferences 12th–14th September 2001*, 11–17. London: Museum of London Archaeology Service.
- van Klinken, G J & Hedges, R E M 1995 'Experiments in Collagen-Humic interactions: Speed of humic uptake, and effects of diverse chemical treatments', *Journal of Archaeological Science* 22: 263–70.
- Krouse, H R & Herbert, M K 1988 'Sulphur and carbon isotope studies of food webs', in Kennedy, B V & LeMoine, G M (eds) *Diet and Subsistence: Current Archaeological Perspectives*, 315–22. Calgary: University of Calgary Archaeological Association.
- Lelong, O 2009 *Langwell Farm, Strath Oykel Excavation Human Remains Call-off Contract: Data Structure Report*. GUARD Project 2818.
- Mant, A K 1987 'Knowledge acquired from post-War exhumations', in Boddington, A, Garland, A N & Janaway, R C (eds) *Death, Decay and Reconstruction: Approaches to archaeology and forensic science*, 65–80. Manchester: Manchester University Press.
- Mays, S, Brickley, M & Dodwell, N 2002 *Human Bones from Archaeological Sites: Guidance for Producing Assessment Documents and Analytical Reports (Centre for Field*

- Archaeology Guidelines*). Swindon: English Heritage/British Association for Biological Anthropology and Osteoarchaeology.
- McAdam, E 1982 'Comparative background: the cemetery', in Watkins 1982, 120–9.
- McCullagh, R 2011 'The monument and the prehistoric landscape at Lairg', in Bradley, R, *Stages and Screens: An investigation of four henge monuments in northern and north-eastern Scotland*, 153–6. Edinburgh: Society of Antiquaries of Scotland.
- McCullagh, R & Tipping, R 1998 *The Lairg Project 1988–1996: The Evolution of an Archaeological Landscape in Northern Scotland*. Edinburgh: Scottish Trust for Archaeological Research.
- MacGregor, G 2007 'Changes in dwelling, people and place', in Lelong, O & MacGregor, G, *The Lands of Ancient Lothian: Interpreting the archaeology of the AI*, 221–37. Edinburgh: Society of Antiquaries of Scotland.
- Médard, F 2010 *L'art du tissage au néolithique: IVe-IIIe millénaires avant J.-C. en Suisse*. Paris: CNRS.
- Melton, N, Montgomery, J, Knüsel, C J, Batt, C, Needham, S, Parker Pearson, M, Sheridan, A, Heron, C, Horsley, T, Schmidt, A, Evans, A, Carter, E, Edwards, H, Hargreaves, M, Janaway, R, Lynnerup, N, Northover, P, O'Connor, S, Ogden, A, Taylor, T, Wastling, V & Wilson, A 2010 'Gristhorpe Man: An early Bronze Age log-coffin burial scientifically defined', *Antiquity* 84: 796–815.
- Melton, N D, Montgomery, J & Knüsel, C J 2013 *Gristhorpe Man: A Life and Death in the Bronze Age*. Oxford & Oakville: Oxbow Books.
- Millard, A 1998 'Bone in the burial environment', in Corfield, M, Hinton, P, Nixon, T & Pollard, M (eds) *Preserving archaeological remains in situ. Proceedings of the PARIS conferences 1st–3rd April 1996*, 93–102. London: Museum of London Archaeology Service.
- Millard, A 2001 'The Deterioration of Bone', in Brothwell, D & Pollard, A M (eds) *Handbook of Archaeological Sciences*, 637–47. Chichester: John Wiley & Sons.
- Montgomery, J, Evans, J A & Neighbour, T 2003 'Sr isotope evidence for population movement within the Hebridean Norse community of NW Scotland', *Journal of the Geological Society* 160: 649–53.
- Morris, B 1998 *The Power of Animals: An Ethnography*. Oxford: Berg.
- Needham, S 2004 'Migdale-Marnoch: Sunburst of Scottish metallurgy', in Shepherd, I A G & Barclay, G (eds) *Scotland in Ancient Europe*, 217–46. Edinburgh: Society of Antiquaries of Scotland.
- Nielsen-Marsh, C M, Smith, C I, Jans, M M E, Nord, A, Kars, H & Collins, M J 2007 'Bone diagenesis in the European Holocene II: Taphonomic and environmental considerations', *Journal of Archaeological Science* 34(9): 1523–31.
- Nisbet, H C 1995 'Excavation of a vitrified Dun at Langwell, Strath Oykel, Sutherland', *Glasgow Archaeological Journal* 19: 51–73.
- Noble, G 2007 'Monumental journeys: Neolithic monument complexes and routeways across Scotland', in Cummings, V & Johnston, R (eds) *Prehistoric Journeys*, 64–74. Oxford: Oxbow.
- Noble, G & Brophy, K 2011 'Ritual and remembrance at a prehistoric ceremonial complex in central Scotland: Excavations at Forteviot, Perth and Kinross', *Antiquity* 85: 787–804.
- Parker Pearson, M, Chamberlain, A, Craig, O, Marshall, P, Mulville, J, Smith, J, Chenery, C, Collins, M, Cook, G, Craig, G, Evans, J, Hiller, J, Montgomery, J, Schwenninger, J-L, Taylor, G & Wess, T 2005 'Evidence for mummification in Bronze Age Britain', *Antiquity* 79: 529–46.
- Parker Pearson, M, Chamberlain, A, Collins, M, Cox, C, Craig, G, Craig, O, Hiller, J, Marshall, P, Mulville, J & Smith, H 2007 'Further evidence for mummification in Bronze Age Britain', *Antiquity* 81: 312–22.
- Person, A, Bocherens, H, Mariotti, A & Renard, M 1996 'Diagenetic evolution and experimental heating of bone phosphate', *Palaeogeography, Palaeoecology and Palaeoecology* 126: 135–49.

- Privat, K L, O'Connell, T C & Hedges, R E M 2007 'The distinction between freshwater- and terrestrial-based diets: Methodological concerns and archaeological applications of sulphur stable isotope analysis', *Journal of Archaeological Science* 34(8): 1197–204.
- Rast-Eicher, A 2005 'Bast before Wool: The first textiles', in Bichler, P (ed) *Hallstatt Textiles: Technical Analysis, Scientific Investigation and Experiments on Iron Age Textiles*, 117–31. Oxford: Archaeopress.
- Richards, M P, Fuller, B T & Hedges, R E M 2001 'Sulphur isotopic variation in ancient bone collagen from Europe: implications for human palaeodiet, residence mobility, and modern pollutant studies', *Earth and Planetary Science Letters* 191(3–4): 185–90.
- Richards, M P, Fuller, B T, Sponheimer, M, Robinson, T & Ayliffe, L 2003 'Sulphur isotopes in palaeodietary studies: A review and results from a controlled feeding experiment', *International Journal of Osteoarchaeology* 13: 37–45.
- Richards, M P, Fuller, B T & Molleson, T I 2006 'Stable isotope palaeodietary study of humans and fauna from the multi-period (Iron Age, Viking and Late Medieval) site of Newark Bay, Orkney,' *Journal of Archaeological Science* 33(1): 122–31.
- Robertson, R 1895 'Notice of the Discovery of a Stone Cist and Urns at the Cuninghar, Tillicoultry; with Notes on the Contents and the Sculptured Covering Stone of the cist; and on the Microscopical Examination of the Fibrous or Hairy Substance found in the Cist', *Proc Soc Antiq Scot* 29: 190–7.
- Robertson-Mackay, M E 1980 'A "head and hoofs" burial beneath a round barrow, with other Neolithic and Bronze Age sites, on Hemp Knoll, near Avebury, Wiltshire', *Proceedings of the Prehistoric Society* 46: 123–76.
- Ryder, M L 1969 'Changes in the fleece of sheep following domestication (with a note on the coat of cattle)', in Ucko, P J & Dimbleby, G E (eds) *The Domestication and Exploitation of Plants and Animals*, 495–521. London: Duckworth.
- Ryder, M L 1992 'Iron Age, haired, animal skins from Hallstatt, Austria', *Oxford Journal of Archaeology* 11(1): 55–67.
- Schultz, M 1997 'Microscopic structure of bone', in Haglund, W D & Sorg, M H (eds) *Forensic Taphonomy: The Post Mortem Fate of Human Remains*, 187–99. Boca Raton: CRC Press.
- Sharples, N 1981 'The excavation of a chambered cairn, the Ord North, at Lairg, Sutherland by J X W P Corcoran', *Proc Soc Antiq Scot* 111: 21–62.
- Shepherd, A 1989 'A note on the orientation of Beaker burials in north-east Scotland', in Greig, M K, Greig, C, Shepherd, A N & Shepherd, I A G, 'A beaker cist from Chapelden, Tore of Troup, Aberdour, Banff and Buchan District', *Proc Soc Antiq Scot* 119: 79–80.
- Shepherd, A 2012 'Stepping Out Together: men, women and their Beakers in time and space', in Allen, Gardiner & Sheridan (eds): 257–80.
- Shepherd, I A G 1986 *Powerful Pots: Beakers in North-east Prehistory*. Aberdeen: Anthropological Museum, University of Aberdeen.
- Sheridan, A 2002 'The radiocarbon dating programmes of the National Museums of Scotland', *Antiquity* 76(293): 794–6.
- Sheridan, A 2005a 'An early historic steatite urn from Orkney: New information on an old find', *Archaeologia Aeliana* (5th series) 34: 158–67.
- Sheridan, A 2005b 'The National Museums of Scotland Radiocarbon Dating Programmes: Results Obtained During 2004/5', *Discovery Excavation Scotland*: 182–3.
- Simmons, T, Cross, P A, Adlam, R E & Moffatt, C 2010 'The influence of insects on decomposition rate in buried and surface remains', *Journal of Forensic Sciences* 55(4): 889–92.
- Smith, C I, Nielsen-Marsh, C M, Jans, M M E & Collins, M J 2007 'Bone diagenesis in the European Holocene I: Patterns and mechanisms', *Journal of Archaeological Science* 34(9): 1485–93.
- Soil Survey of Scotland 1982 *Northern Scotland, Sheet 3, 1:250,000*. Aberdeen: The Macaulay Institute for Soil Research.

- Stathopoulou, E T, Psycharis, V, Chryssikos, G D, Gionis, V & Theodorou, G 2008 'Bone diagenesis: New data from infrared spectroscopy and X-ray diffraction', *Palaeogeography, Palaeoclimatology, Palaeoecology* 14: 168–74.
- Stout, S D 1986 'The use of bone histomorphometry in skeletal identification: The case of Francisco Pizarro', *Journal of Forensic Sciences* 31(1): 296–300.
- Textile Institute 1975 *Identification of Textile Materials*, 7th edn. Manchester: The Textile Institute.
- Thompson, D D & Cowen, K S 1984 'Age at death and bone biology of the barrow mummies', *Arctic Anthropology* 21(1): 83–8.
- Thompson, T J U, Gauthier, M & Islam, M 2009 'The application of a new method of Fourier Transform Infrared Spectroscopy to the analysis of burned bone', *Journal of Archaeological Science* 14: 910–14.
- Tipping, R 2008 'Blanket peat in the Scottish Highlands: Timing, cause, spread and the myth of environmental determinism', *Biodiversity and Conservation* 17: 2097–113.
- Turner-Walker, G, Nielsen-Marsh, C M, Syversen, U, Kars, H & Collins, M J 2002 'Sub-micron spongiform porosity is the major ultra-structural alteration occurring in archaeological bone', *International Journal of Osteoarchaeology* 12: 407–14.
- Turner-Walker, G & Jans, M 2008 'Reconstructing taphonomic histories using histological analysis', *Palaeogeography, Palaeoclimatology, Palaeoecology* 266: 227–35.
- Ubelaker, D H & Zarenko, K M 2010 'Adipocere: What is known after over two centuries of research,' *Forensic Science International* 208: 167–72.
- Vogt, E 1937 *Geflechte und Gewebe der Steinzeit*. Basel: E Birkhäuser & Cie.
- Walton Rogers, P 1999 *Fibres on a Bronze-Age Bangle from Ingleby Barwick, Teesside (IWF 96)*. Unpublished Textile Research Report on behalf of Tees Archaeology.
- Walton Rogers, P 2005 'Report on the animal hide', in Sheridan 2005a: 164.
- Walton Rogers, P 2013 'Organic residue', in Arabaolaza 2013: 13.
- Walton Rogers, P n.d. *Samples of animal pelt from Derrykeigan, Co Antrim*. Unpublished Anglo-Saxon Laboratory Report on behalf of The National Museum of Ireland.
- Walton, P & Eastwood, G 1988 *A Brief Guide to the Cataloguing of Archaeological Textiles*, 4th edn. London: Institute of Archaeology.
- Watkins, T 1982 'The excavation of an Early Bronze Age cemetery at Barns Farm, Dalgety, Fife', *Proc Soc Antiq Scot* 112: 48–141.
- Weiner, S & Bar Yosef, O 1990 'States of preservation of bones from prehistoric sites in the Near-East: A survey', *Journal of Archaeological Science* 14: 187–96.
- Weinstein, R S, Simmons, D J & Lovejoy, C O 1981 'Ancient bone disease in a Peruvian mummy revealed by quantitative skeletal histomorphometry', *American Journal of Physical Anthropology* 54: 321–6.
- Welfare, H G 1977 'A Bronze Age cemetery at Ferniegair, Lanarkshire', *Proc Soc Antiq Scot* 106: 1–14.
- White, L 2009 *The Microbiology of Death*. Unpublished PhD thesis, University of Sheffield.
- Wildman, A B 1954 *The Microscopy of Animal Textile Fibres*. Leeds: WIRA.
- Wilkin, N 2010 'Soul of the Age? New light on Roseisle's "big man" and the Early Bronze Age funerary practices of the Moray Firth region', in *Beakers, Bones & Birnie: Archaeological works in progress associated with Elgin Museum. Proceedings of The Moray Society Annual Conference, 25th–26th April 2009*, 45–68. Elgin: The Moray Society.
- Wilkin, N 2012 'Animal remains from late Neolithic and Early Bronze Age funerary contexts in Wiltshire, Dorset and Oxfordshire', *The Archaeological Journal* 169.
- Wilkin, N, Curtis, N, Hutchison, M & Wright, M 2009 'Further radiocarbon dating results from the Beakers and Bodies Project', *Discovery and Excavation Scotland*: 216–18.