

NHS AT HOME: A CO-DESIGN RESEARCH PROJECT TO DEVELOP A 21ST CENTURY NURSING BAG

David Swann^{1,2}

*Royal College of Art
University of Huddersfield*

The black nursing bag, the indispensable tool of the district nurse, has remained virtually unchanged for over 100 years. The goal of the research is to equip newly formed neighbourhood care teams with a 21st century nursing bag that improves service delivery and patient safety performances through co-design. This work in progress paper outlines the collaborative processes that have steered the development of a 21st century nursing bag. NHS at Home is a PhD by practice, based at the Royal College of Art, London and is sponsored by NHS East Riding of Yorkshire and the EPSRC.

Introduction

In rising to social, demographic and economic change, the devolution of hospital treatments into community settings continues to gain momentum (Darzi, 2006). In 2009, NHS East Riding of Yorkshire (NHS ERY) introduced Neighbourhood Care Teams (NCTs) to provide an integrated care service that responded to the complex healthcare needs of older patients by delivering planned treatments in the comfort of their own homes. Whilst new organizational structures have been specially developed, no dedicated equipment exists to support community matrons working in this challenging and inconsistent healthcare setting. To support this paradigm shift, new ways of working and new types of equipment are necessary as nursing bags are now perceived to be unfit for purpose: 21st century professionals using 20th equipment (Kitzman et al, 2002; Bakunas-Kenneley et al, 2009). A key objective of the study is to co-design a world-class nursing bag to the benefit of NHS commissioners, healthcare professionals and patients.

Research methods and aims

The core aims of the study are to understand how nursing bags support the delivery of planned treatments in an unpredictable domestic setting, to identify opportunities for new product development and to collectively identify the clinical and design performance requirements needed for a 21st century nursing bag.

Two types of data were collected; a literature review and empirical data collected from service evaluations, analysis of nursing bags, quantitative testing and stakeholder workshops. Applied research data has informed an iterative co-design programme with stakeholders from NHS East Riding.

Service evaluations

The shadowing of Neighbourhood Care Teams (NCTs) from Bridlington and Goole enabled the observation of home-based treatments delivered in a broad cross-section of buildings: bungalows, terraced houses, care homes and caravans. Analysis revealed variations in domestic environments: spatial availability, the physical environment and levels of cleanliness. The unpredictability of domestic environments makes improvisation a pre-requisite skill for nurses working in this setting. Observations captured nurses creating treatment spaces sandwiched in between bedroom furniture, on dining tables cluttered with patient medication and more often than not, on the living room floor. Empirical data captured the physicality of this profession; with high incidences of nurses carrying multiple bags and repetitive bending/ stretching that may contribute to work-related absenteeism reported by this NHS group (Boorman, 2009).

Analysis of nursing bags

The Health & Safety at Work Act (1974) provides a statutory legal requirement for employers to protect the health, safety and welfare of employees at work. An employee's well-being is further protected by the Provision and Use of Work Equipment (1998); a statutory law to ensure that workers are equipped with safe and fit for purpose equipment to perform their roles. Service evaluations highlighted an absence of nursing bag specifically designed to address the challenges faced by healthcare professionals working in this environment. This has necessitated the procurement of bags designed for non-healthcare applications: camera bags, plastic toolboxes and accountant cases (Figure 1). An analysis of these improvised bags exposed variations in bag type, design, weight and materials; with bags weighing 2 to 5 kgs and manufactured from absorbent materials that are considered to the harbour bacteria (Bakunas-Kennerley et al 2009).



Figure 1: A camera bag used as an improvised nursing bag

Hospital acquired infections such as Meticillin-Resistant Staphylococcus Aureus

(MRSA) is now considered to be a main disease threat in Europe (ECDPC 2007). Davis & Madigan (1999) suggests the proliferation of drug-resistant infections such as MRSA, makes nursing bags both outdated and dangerous. The use of improvised bags, an absence of National Patient Safety Agency cleaning recommendations together with the high number of patient visits a nurse can make each day (up to 17) raised concerns for the potential transfer of harmful bacteria. Studies and surveillance data pertaining to the risks posed by the bacterial contamination of nursing bags is extremely sparse. The Bakunas-Kenneley study (2009) examined 126 nursing bags with 15.9% of bags surveyed registering positive results for *Escherichia coli*, *Pseudo-monas aeruginosa* and MRSA. The study recommended the use of non-porous materials and a daily cleaning regime to decrease contamination rates.

To investigate this subject area further, a first batch of nursing bags was microbiologically tested: aerobic plate count, Enterobacteriaceae, *Escherichia coli* (E-Coli) and *Staphylococcus Aureus* (Staph. A.). The first two tests provided a general marker of hygiene with the remaining tests screening for two commonly found hospital-acquired infections. Each bag's interior and exterior surfaces were swabbed and the process repeated on a brand new bag to provide control data and test efficacy. In addition, identical tests were performed inside the vehicles owned by nurses, specifically where bags are stored during transit. This evaluation is ongoing with findings to date presented in Table 1. Food hygiene standards acknowledge that 5 colony forming unit/cm² (CFUs) to be within safety limits, while clinical evidence suggests as few as 10 CFUs can potentially cause a Staph. A. infection (Dancer, 2008).

Table 1: Microbiology found on nurse's bags and on car boot floors

	Aerobic Count	Enterobacteriaceae.	E-coli	Staph. A.
Control Bag: exterior	<1	<1	<1	<1
Control Bag: interior	<1	<1	<1	<1
Control Car boot floor	<1	<1	<1	<1
Bag 1: exterior	4	<1	<1	<1
Bag 1: interior	140	<1	<1	3
Car 1: boot floor	13	<1	<1	<1
Bag 2: exterior	95	4	<1	<1
Bag 2: interior	9	<1	<1	<1
Car 2: boot floor*	>1000	>1000	<1	<1
Bag 3: exterior	4	<1	<1	<1
Bag 3: interior	<1	<1	<1	<1

Car 3: boot floor*	>8400	>3700	<1	<1
--------------------	-------	-------	----	----

* *travel rugs used as a protective barrier*

Co-design project

The understanding of complex problems can be achieved by viewing the problem from multiple perspectives. Professional diversity brings new ways of thinking and provides design solutions with greater degree of accuracy as knowledge resides in not just designers but everyone (Schön, 1983). Elvin & Levin (1991) emphasizes the benefits of collaboration where employees contribute their tacit knowledge of organisational systems and complemented by an outsider who brings specialist knowledge of process and systematic enquiry. The principles of participatory action research have now permeated contemporary design practice. The emergence of co-design builds on these principles through the co-creation of new knowledge that manifests itself through the production of intellectual property.

A dedicated steering group consisting of community matrons, service improvement managers, infection control specialists and the associate director for design innovation provides a forum to test, evaluate and inform design decisions. The first stakeholder workshop explored aspirational service architectures and products, the second focused on issues of typology and performance, a third evaluated issues of clinical functionality, a fourth assessed the impact of design features on infection control and a fifth determined the optimal hand cleaning technique.

Lego Serious Play workshop: envisioning aspirational services/ products
 Lego Serious Play (LSP) is widely used as visual linguistic tool to express strategic planning opportunities by major corporations such as Nokia and Microsoft. The application of LSP as a research methodology is rarely used in the social sciences and absent from design research. The primary objective of workshop was to build upon the ethnographical data acquired through fieldwork activities and to envision opportunities for service improvements and new product development. The workshop was structured into a series of sequential building activities incorporating both generic LSP exercises and modified tasks: perception models, individual day in the life models. The workshop concluded with the collective building of metaphorical representations of aspirational service architectures and supporting products. One aspirational Lego model highlighted a need for a corporate 'product' that provided a professional, organized and a uniformed work environment – a new nursing bag

'Now this pod can be a pod inside a hospital or a clinic or can be in our bags or our environment we are trying to get in our patient's homes. And this will probably be our work environment. We can stand up and work around it. So it's very much mobile. You know, everything is in its place. So, so we open it up and it's all uniformed. So that's my idea.'

Steering group workshop: design typologies & performance requirements

A series of co-design exercises determined the frequency of treatment types, spatial requirements for a treatment field and capacity requirements required to contain clinical materials. These performance outcomes directed a concept exploration phase that produced three product typologies: a wheeled trolley bag, a bag with an integrated leg system and a treatment field product. Design concepts were presented to the steering group supported by low fidelity models that communicated visual and functional data. Rubinoff's qualitative tool provided a framework to evaluate each concept's perceived performances in functionality, usability, product features and image. The resultant findings have directed the primary components for a new nursing bag:

- A hard-sided bag
- Integrated treatment space
- Simplicity of design, operation and speedy deployment.
- Open system: modular drawers
- A 'backless' design to aid effective cleaning
- Elimination of all fasteners and surface protrusions that can inhibit cleaning
- Reduction of components to minimise bacteria traps caused by part assembly

Steering group workshop: evaluating clinical functionality

To test the clinical functionality of the preferred design concept a medium fidelity 'proof of principle' prototype was produced and evaluated. The steering group evaluated: (i) the capacity of drawer size for the containment of diagnostic equipment and patient materials; (ii) simulated the treatment delivery of a leg ulcer dressing and a catheter procedure using a traditional bag (Figure 2); (iii) simulations repeated with the proof of principle prototype (Figure 3). Second by second analysis of video recordings informed the production of task and link analysis data.

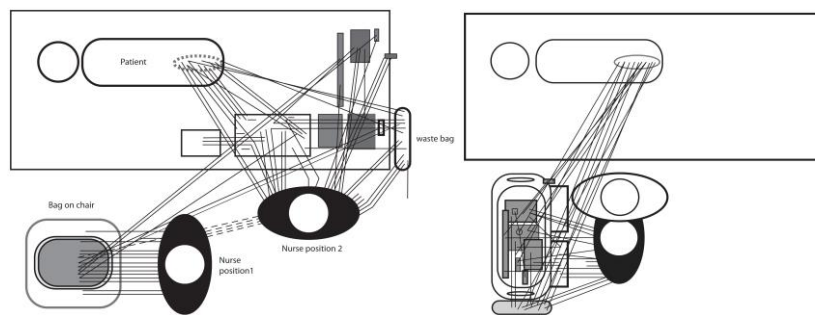

Figure 2: Comparative link analysis- old bag/ new bag with treatment surface

In reviewing the video data pertaining to the use of a traditional bag highlighted user issues with bag pockets. Clinical items stored in pockets required nurses to adopt a

'search to retrieve' technique as their contents are obscured from view. The layering effect of treatment items inside the bag's main storage compartment exacerbated this problem further. With the new bag, the adoption of a drawer system overcomes these issues, while with the improved proximity of contents to treatment space minimises repetitive bending and reaching. Participants also stated that they experienced improvements to their general posture due to an elevated treatment space that supported the patient's foot during the procedure.

Steering group workshop: optimising infection control design

Frequent cleaning reduces the risk of product deterioration and the patient safety issues associated with the presence of bacteria (Collins, 1988). National Patient Safety Agency's National (NPSA) Specification for Cleanliness in the NHS provides clear recommendations to ambulance trusts on the expected frequency and cleaning standards for emergency response bags. However, no NPSA guidelines exist for nursing bags. Patient safety is a fundamental requirement of any medical device. To understand the impact that design features can have on effective hand cleaning an evaluative tool was adapted. In hospitals, a UV based training tool is used to demonstrate the effectiveness of hand washing techniques to prevent cross-contamination. This training tool consists of a UV sensitive gel and a UVA light source. UV sensitive particles contained within the gel illuminate when lit by a UVA lamp, visually exposing any areas that have been missed during the hand washing process. This tool was used to assess the cleaning ability of alternative design features by applying and removing a coating of UV gel with a biocidal wipe. This technique was applied to: (i) 'ready-made objects' of differing design profiles; (ii) a FDM prototype drawer depicting alternative corner solutions and dimensional data; (iii) treatment surfaces with differing handle apertures and (iv) FDM models with differing base solutions. These tests enabled the optimization of bag and drawer design features to attain efficacious hand cleaning.

Analysis of hand wiping techniques: side-to-side versus radial

The preceding UV tests identified a discrepancy in the hand cleaning techniques being applied. The NPSA's Revised Healthcare Cleaning Manual recommends for a product of a similar surface area, that a methodical side-to-side wiping technique be used. However, nurses in the tests utilised a different technique. This was a circular action starting a central location and radiated outwards to the perimeter of the product. To determine which technique applied the most hand pressure a simple diagnostic test was performed. The test involved a 50cm² delineated area and a wearable glove incorporating tactile sensors that captured in real-time digit/ palm pressure data. The designated area was cleaned with a biocidal wipe using both techniques. Analysis of the two data sets revealed that the pressure applied by the palm area was comparable, however significant differences were found in the pressures being applied by the digits. When using a side-to-side technique, digits applied pressures ranging from 0.60 to 2.86 kgs (Figure 3). By contrast, when using a radial technique, digits applied pressures of 0.03 to 0.21 kgs; pressures lower than the palm area. This finding validates NPSA's recommendations and has determined the positioning of design features on the treatment surface.

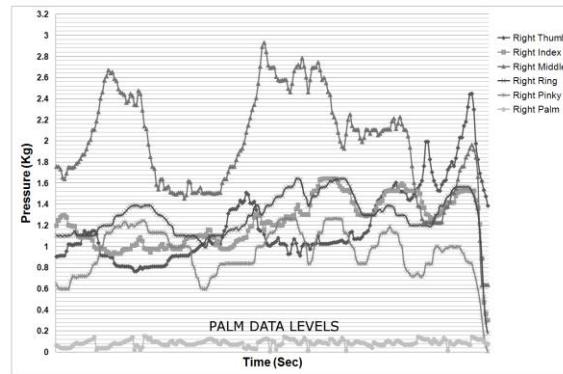

Figure 3: Palm and digit pressure data; side-to-side cleaning technique

Future Work

To date the project has attracted international, national and regional attention as well commercial interest. The collaborative design research is now entering a validation phase to verify the effectiveness of a high fidelity ‘proof of concept’ prototype (Figure 4). A comparative study will involve the simulated delivery of treatments using the traditional bag and the new bag with Neighbourhood Care Teams.

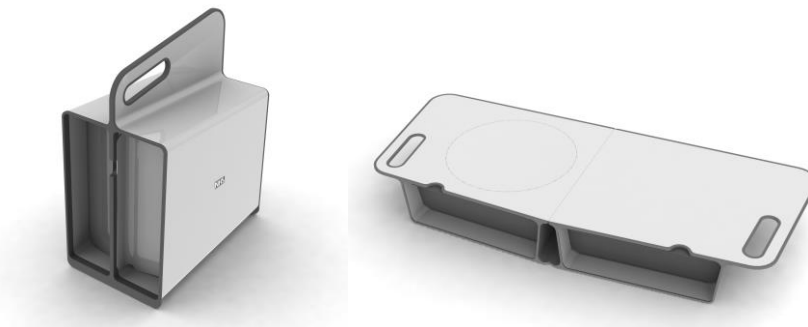

Figure 4: Proposed bag incorporating an integrated treatment space

The success of the project should not only be measured by its ability to improve performances in productivity, functionality and patient safety performances using a design-led approach, but also the collaborative and inter-disciplinary partnership that has enabled this project to succeed. As Henry Ford observed, “coming together is a beginning, keeping together is progress, working together is success.”

References

- Abrams, S.E. 2009. The Public Health Nursing Bag as a Tool and Symbol, *Public Health Nursing*, Vol.26, No.1, (Wiley-Blackwell, Hoboken), 106-109
- Amato-Gauci, A and Ammon, A. 2007. The First Communicable Disease Epidemiological Report (European Centre for Disease Prevention and Control)
- Bakunas_Kenneley, I and Madigan, E.A. 2009. Infection Prevention and Control in Home Health: The Nurse's Bag. *American Journal of Infection Control*, Vol.37, Issue 8, (Elsevier Inc, New York), 687-688
- Boorman, S. 2009. *NHS Health and Well-being- Final Report* (Crown)
- Bosanquet, N., Cawston, T., Haldenby, A and Seddon. N., 2010. *Fewer Hospitals, More Competition* (Reform)
- Collins, B.J, 1988. The Hospital Environment: How Clean Should a Hospital Be? *Journal of Hospital Infections*, 11, (Elsevier Inc, New York), 53-56
- Dancer, S.J. 2008. Importance of the Environment in Meticillin-Resistant Staphylococcus Aureus Acquisition: The Case for Hospital Cleaning. *The Lancet Infectious Diseases*, Vol.8, Issue 2, (The Lancet Publishing Group, London), 101-113
- Davis, P.L and Madigan E.A. 1999. Evidenced-based Practice and the Home Care Nurses's Bag, *Home Healthcare Nurse*, (Home Healthcare Nurses Association, Washington), 17:295-299
- Department of Health. 2006, *Our Health, Our Care, Our Say: A New Direction for Community Services*. (TSO)
- Gaunlett, D. 2007. *Creative Explorations; New Approaches to Identities and Audiences*. (Routledge, London)
- Lee, E. 2006. *Developing & Evaluating a Nursing Bag System for Homecare Nurses using a Participatory Ergonomic Approach* *Home Healthcare Nurse* (Home Healthcare Nurses Association, Washington), Vol.24, Issue 9, 551-616
- Kitzman, K., Pett, M. and Bloswick, D. (2002) An Exploratory Study of Nurse Bag use in Home Visiting Nurses, *Home Healthcare Nurse Journal*, (Home Healthcare Nurses Association, Washington), 20(4), 553-558
- National Patient Safety Agency, 2007. *The National Specifications for Cleanliness in the NHS: A Framework for Setting and Measuring Performance Outcomes in Ambulance Trust*, (NPSA)
- Rhinehart, E. 2001, Infection Control in Home Care. *Emerging Infectious Diseases*, Vol. 7, No.2, (Center for Disease Control and Prevention, Atlanta), 208-211
- Schön D.A. 1963. *Displacement of Concepts*. First Ed. (Tavistock Publications, London)
- Schön D.A.1983. *The Reflective Practitioner*. (Basic Books Inc, USA)
- Sitzman, K.L, Marjorie A.P and Bloswick, D. 2002, An exploratory Study of Nurse Bag use in Home Visiting Nurses. *Home Healthcare Journal*, 20(4), (Lipincott Williams & Wilkins, Philadelphia), 553-558
- The Cabinet Office. 2008, *Realising Britain's Potential: Future Strategic Challenges for Britain*, (The Strategy Unit, London)
- The Cabinet Office, 2008. *Excellence And Fairness: Achieving World Class Public Services*. (Crown)
- Varney. D. 2006. *Service Transformation: A better Service for Citizens and Businesses, a Better Deal for Tax Payers*. (HM Treasury)

Young, B.,2006. *Designing Design in a Complex World: The Evolution of Service (Systems) Design Thinking in Academia*. Paper presented at the International Service Design, Northumbria University, 31st March 2006