

Open Research Online

The Open University's repository of research publications and other research outputs

Next Steps for Hydrogen - physics, technology and the future

Other

How to cite:

Nuttall, William; Glowacki, Bartek and Krishnamurthy, Satheesh (2016). Next Steps for Hydrogen - physics, technology and the future. Institute of Physics, London.

For guidance on citations see [FAQs](#).

© 2016 The Authors

Version: Version of Record

Link(s) to article on publisher's website:

http://www.iop.org/publications/iop/2016/file_67429.pdf

Copyright and Moral Rights for the articles on this site are retained by the individual authors and/or other copyright owners. For more information on Open Research Online's data [policy](#) on reuse of materials please consult the policies page.

oro.open.ac.uk

A report prepared for the Institute of Physics | May 2016

Next Steps for Hydrogen

Physics, technology and the future

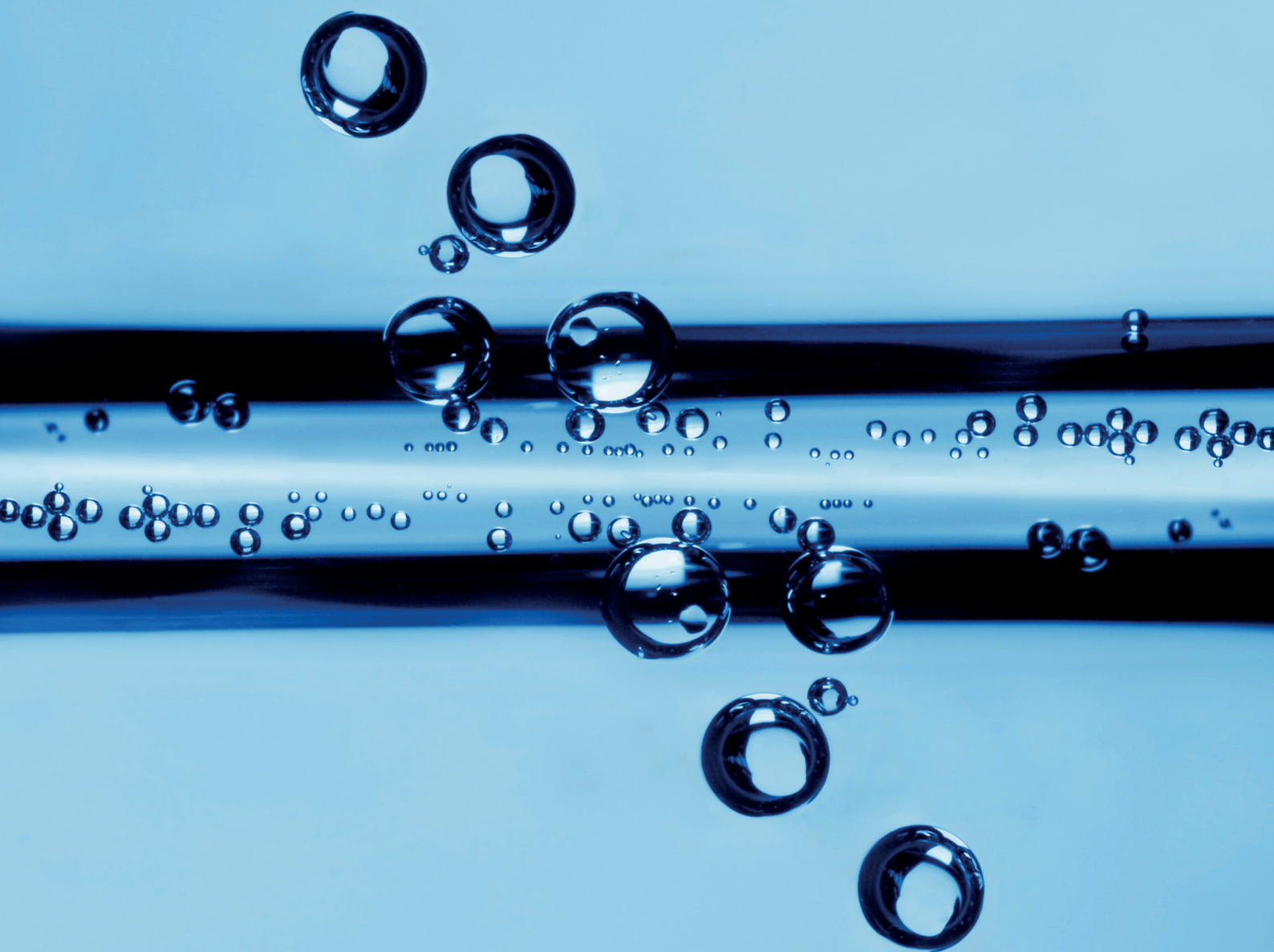

The Institute of Physics is a leading scientific society. We are a charitable organisation with a worldwide membership of more than 50,000, working together to advance physics education, research and application. We engage with policymakers and the general public to develop awareness and understanding of the value of physics and, through IOP Publishing, we are world leaders in professional scientific communications.

This report was written by:

William J Nuttall, Department of Engineering and Innovation, The Open University, UK

Bartek Glowacki, Bernal Institute of Department of Physics and Energy, University of Limerick; Department of Materials Science and Metallurgy, University of Cambridge; Institute of Power Engineering, Warsaw

Satheesh Krishnamurthy, Department of Engineering and Innovation, The Open University, UK

Contents

Summary	4
Preface	5
1. Introduction	6
2. Low-emission vehicles	8
3. Physicists and hydrogen	12
4. Current use of hydrogen	13
5. Journey to the hydrogen economy	14
6. Cryogenic liquid hydrogen	24
7. Hydrogen safety: perceptions and realities	34
8. Potential disruptive innovations	35
9. Conclusions	37
10. Acknowledgements	38
11. References	39

Summary

Hydrogen has been proposed as a future energy carrier for more than 40 years. In recent decades, impetus has been given by the need to reduce global greenhouse gas emissions from vehicles. In addition, hydrogen has the potential to facilitate the large-scale deployment of variable renewables in the electricity system. Despite such drivers, the long-anticipated hydrogen economy is proving to be slow to emerge. This report stresses the role that physics and physics-based technology could play in accelerating the large-scale deployment of hydrogen in the energy system.

Emphasis is given to the potential of cryogenic liquid hydrogen and the opportunities afforded by developments in nanoscience for hydrogen storage and use. The use of low-temperature liquid hydrogen opens up a technological opportunity separate from, but complementary with, energy applications. The new opportunity is the ability to cool novel materials into the superconducting state without the need to use significant quantities of expensive liquid helium. Two of the authors have previously coined the term “hydrogen cryomagnetism” for when liquid hydrogen is utilised in high-field and high-efficiency magnets. The opportunity for liquid hydrogen to displace liquid helium may be a relatively small business opportunity compared to global transport energy demands, but it potentially affords an opportunity to kick-start the wider commercial use of hydrogen.

The report considers various important factors shaping the future for hydrogen, such as competing production methods and the importance of safety, but throughout it is clear that science and engineering are of central importance to hydrogen innovation and physics has an important role to play.

Preface

Hydrogen has been proposed as an energy carrier for more than 40 years. Hydrogen is not a fuel in the conventional sense, as it must be manufactured using primary energy resources. As such, it has similarities to electricity, but it differs from electricity in several key respects relating to cost, storage, safety and transport.

At the turn of the millennium there was much interest in hydrogen as a potential low-carbon energy source for vehicles. In the ensuing years, however, enthusiasm and research budgets diminished in the face of higher than expected costs, technical difficulties and competition from rapidly improving battery technology for electric vehicles. Consequently, in recent years there has been reduced interest in hydrogen as a clean energy carrier. New circumstances, however, are starting to prompt a resurgence of interest. Drivers of a hydrogen resurgence include growing concern regarding the availability of metals required for advanced batteries, fire safety concerns around battery technology, the rapid growth of natural gas as a primary fuel (noting its role as the precursor of conventional and current hydrogen production) and a growing recognition that liquid hydrogen at 20 K, or $-253\text{ }^{\circ}\text{C}$, can act as a substitute for liquid helium. In this role, hydrogen would not only be an energy carrier, but also a cryogenic liquid substituting for 4.2 K helium in a world of rising helium prices. Another important driver for hydrogen has been increasing policy enthusiasm for renewable electricity production. Most renewables, including wind and solar energy, have time-varying output depending on the weather or the rotation of the Earth. Sometimes, renewables are described as being “intermittent” producers of power but this terminology can mask the reality that in many respects renewable-energy variability is predictable.

High renewable-energy scenarios motivate a radical rethink of the role of energy storage, and hydrogen may have an important role to play. Such thinking figures prominently in the European Union’s energy-systems planning.

This report gives emphasis to technological insight and innovation emerging from laboratories and stresses how this is contributing to the renewed interest in hydrogen.

Introduction

The phrase “hydrogen economy” dates from 1970 when electrochemist John Bockris coined the term during a meeting at the General Motors Technical Centre. Despite more than 40 years having passed, full-scale commercialisation of hydrogen as an energy carrier has not been achieved. Enthusiasm for hydrogen has waxed and waned over the years. Currently, interest in the potential for hydrogen is growing again driven primarily by two factors: first, energy policy (especially the pressure to deploy intermittent renewable sources of electricity) and second, innovations throughout the hydrogen value chain.

This report focusses on the role that physics and physicists can play in shaping the future of a hydrogen economy. Such a hydrogen economy has been envisaged over many years, but remains a goal to be achieved. There exists the possibility that a disruptive set of innovations from the laboratory might be the spur to create the long-awaited hydrogen economy.

The technology issues of hydrogen are divided into two almost entirely separate worlds. On the one hand there is the existing hydrogen industry based on fossil fuels and supplying a chemical feedstock for industries such as ammonia production and oil refining. On the other, there is the potential of hydrogen as a future energy vector especially interfacing between vehicle needs and renewable-electricity generation. Both aspects are affected by the requirements of environmental sustainability to decarbonise energy and to improve air quality. As things stand, the role of hydrogen as an industrial process gas dominates hydrogen economics while the prospect of hydrogen as a clean energy carrier attracts

much policymaker and researcher interest. In this report we shall consider both aspects looking to the future and with a special emphasis on the role that physics and physicists can play.

In the UK there is policy pressure to increase greatly the share of renewables in total energy. There is a nominally binding European Union (EU) target for 15% of total UK energy supply to come from renewables by 2020. Progress has been slow and difficult, and in 2012 the UK achieved only 4.1% renewables in total energy overall. Electricity can accommodate moderate amounts of renewable energy relatively easily (at least compared to heating and transport). The EU agreed in 2014 a set of new energy and climate targets for 2030. These targets included cutting greenhouse-gas emissions by 40% compared to 1990 levels and a binding commitment to meet 27% of all EU energy needs through renewable energy – a commitment that the EU led with at the COP21 meeting in Paris in December 2015. However, this latter target is only applicable at the EU level and not for each individual member state, partially due to lobbying from the UK. Despite this target requiring less commitment from states individually, it is nevertheless clear that renewables will play a growing role in the European electricity system. The increasing presence of renewables will in turn generate growing pressure to develop affordable and highly efficient energy-storage options (including hydrogen-based storage).

Transport has a key role to play in meeting energy policy goals and there is a need to find an alternative transport fuel to oil-derived petrol and diesel. Hydrogen is one pathway to a lower-emission transport system.

UK Final Energy Consumption 2012 by usage sector and also showing the fuels used in transport (million tonnes of oil equivalent). Source: National Statistics/DECC UK Energy in Brief 2013

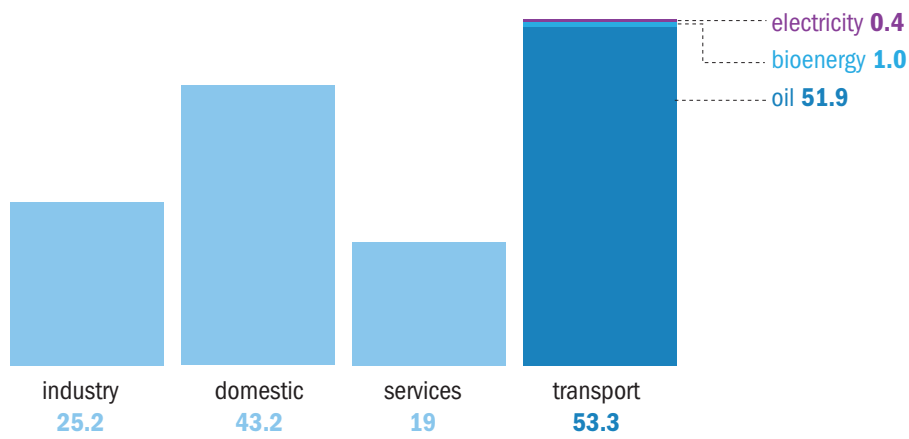

Low-emission vehicles

Transport plays a major role in UK energy consumption. In 2013, the total UK greenhouse gas emissions are estimated to have been 568.3 million tonnes of carbon dioxide (CO₂) equivalent, of which 116.8 million tonnes were from transport (20.6%) [1]. Various avenues are open to improving the emissions performance of vehicles. These include efficiency improvements in conventional power trains and also reducing the weight of vehicles. These two measures alone offer much potential and they feature in the Gordon Murray designed T.25 low-emission vehicle based upon Formula 1 technology. While significant improvements can be achieved while retaining fossil fuel internal combustion, even greater benefits can in principle be obtained by shifting to intrinsically low-carbon vehicle fuels, such as sustainable biofuels. In 2014, transport biofuels comprised 9.2% of all UK renewables usage. A widely adopted, and similarly low-carbon, alternative is to use electricity generated from renewable sources (or nuclear power). However, when considering electrified transport, it should be remembered that despite many years of policy pressure towards a low greenhouse gas (GHG) emissions electricity system, the reality is that overall, 57% of 2014 UK electricity was generated in the UK using fossil fuels (primarily

natural gas and coal) [1]. In 2014, 19.1% of electricity was supplied from renewable sources. Renewable energy of any type (including electricity generated from renewables) contributed just 4.8% to transport energy needs in 2014. If we are to meet the climate challenge and GHG emission reduction targets, then the use of low-carbon options to power vehicles must increase significantly. The future of the transport sector could rely on strengthening the role of two already deployed non-fossil fuel options – electricity and bioenergy. Hydrogen, however, represents a new third option and arguably it has benefits beyond those of the more established competitor low-carbon approaches. For example, while bioenergy is indeed a fuel in the conventional sense, with the possible exception of Brazilian sugarcane, it is not a zero CO₂ emissions option.

Electricity and hydrogen are energy carriers and not primary fuels in the conventional sense. Both need to be generated using primary energy sources and hence, both are only as clean as the energy sources used in their production. As noted earlier, two-thirds of UK electricity is currently generated using fossil fuels. Despite the goals for the future, electricity is currently far from being a low GHG emissions industry – actually the hydrogen industry is in a similar position. Indeed, the reality is that

Lifecycle CO₂ emissions of various bioethanol and biodiesel compared respectively to petrol and diesel. Source: Parliamentary Office of Science and Technology, Transport biofuels, POSTNotes 293 (2007)

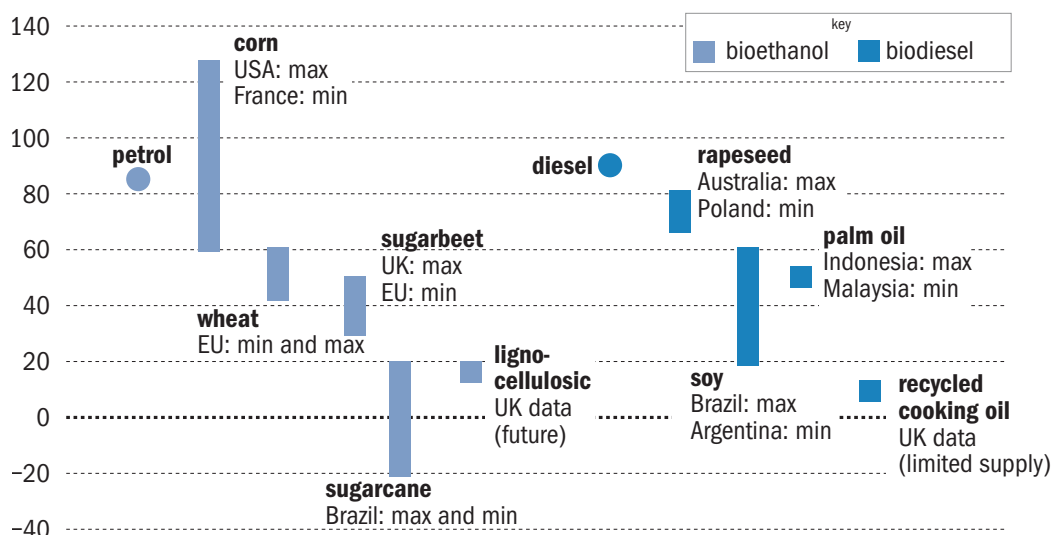

hydrogen currently lags behind electricity in terms of low-carbon credentials as fossil fuels are currently the source of 96% of hydrogen produced.

Having noted that both electricity and hydrogen production have the potential to be significantly decarbonised, they appear with sustainable biofuels to be the three best routes to a low-carbon transport system.

The future of electricity is complicated by two competing factors:

- Improved end-use efficiency is currently contributing to downward pressure on electricity demand in advanced economies
- However, the prospect of increased electrification of heating and transport is likely to increase total electricity demand in those countries

Global Hydrogen Production (2005). Source: R Guerrero-Lemus and J M Martínez-Durant, International Journal Hydrogen Energy 35 (2010)

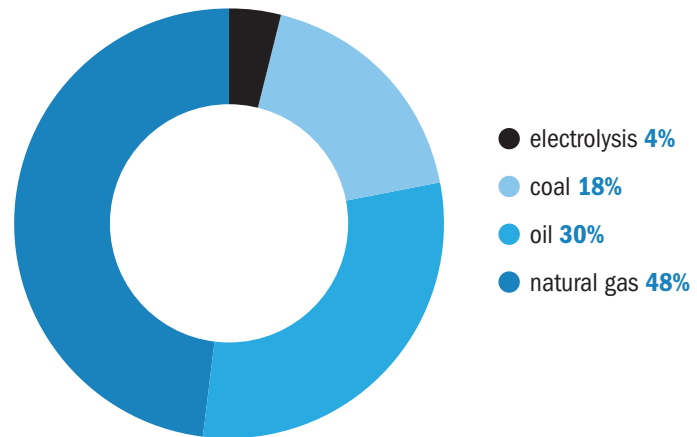

Three competing low-carbon vehicle power train options

	Biofuels	Battery electric vehicles	Hydrogen fuel-cell electric vehicles
Positive attributes	Technologies deployed and in use	Technologies deployed and in use	Technologies demonstrated
	Use of existing petroleum and diesel supply chains and infrastructures	Major car manufacturer investment and capability	Evolutionary product transition for existing international oil companies
	No adjustment required to vehicles or driver behaviour	Potential synergies with “smart grids” and “smart homes”	Moderately long-range (350 km+) and rapid filling station refuel (approximately three minutes)
		Zero tailpipe emissions	Only tailpipe emission is water
			Fuel-cell reliability and longevity in use
Negative attributes	Relatively modest GHG benefits and life-cycle delays until maximum benefits are realised	Relies on resource limited elements (eg lithium)	Significant economic barriers to deployment, notably in infrastructure and supply chains
	Usually requires blending with fossil fuels, especially for unadjusted vehicles	Only as clean as the related electricity generation technology	Poor public perceptions of safety
	Concern about impacts on agriculture, global food security and land-use	Limited vehicle range and risk of driver “range anxiety”	
	Subject to full value added tax in the UK, but there is an effective exemption from fuel duties	Vehicle heating a challenge for cold, winter climates	
		Relatively slow recharge times and hence a need for adjustments in driver behaviour	
		Battery fire risks	

2: Low-emission vehicles

The electrification of heat and transport will bring challenges, but also important benefits. For example, transport applications of electricity (such as vehicle battery charging or even hydrogen generation) may be timed to match electricity generation at times when supply would otherwise exceed demand. Such developments have the potential to smooth electricity system balancing especially in the face of growing system volatility arising, in part, from intermittent renewables such as wind or sunshine.

Underlying such futures will be an increasing policy pressure to decarbonise the electricity generation system. However, thus far, and for a range of reasons, progress towards UK electricity decarbonisation has stalled over the last 15 years. Recent moves towards electricity market reform and long-term guaranteed prices for large-scale generators of low-carbon electricity aim to reduce UK electricity greenhouse gas emissions significantly in the years and decades to come.

In 2011, Contestabile and co-workers examined the contest between battery electric vehicles, hydrogen fuel cells, and biofuels [2]. They reviewed

earlier work and noted that several important complexities and dynamic effects, particularly around evolving driver behaviour tended to have been neglected. They assess the competing technologies against the test of total cost of ownership and conclude that the competition is very tight, such that expected advantages are smaller than the confidence bands of the assessments. They suggest that taking greater account of behavioural change could allow a front-runner technology to emerge.

Innovation to displace petrol and diesel in Europe has a key advantage over change in other parts of the energy economy. The advantage comes from the very high proportion of tax levied on liquid fossil fuels for transport. Assuming that substitutes (electricity, biofuels or hydrogen) can avoid similar taxes, then the new entrants will have a significant advantage over the incumbent fuels in the retail market that could greatly assist them overcome the significant barriers to entry, such as a lack of underpinning infrastructure.

While electric vehicles have made much progress in recent years, such innovation represents a

UK CO₂ emissions from electricity generation (Mt). Source: Department of Energy and Climate Change, Statistical Release, March 2013

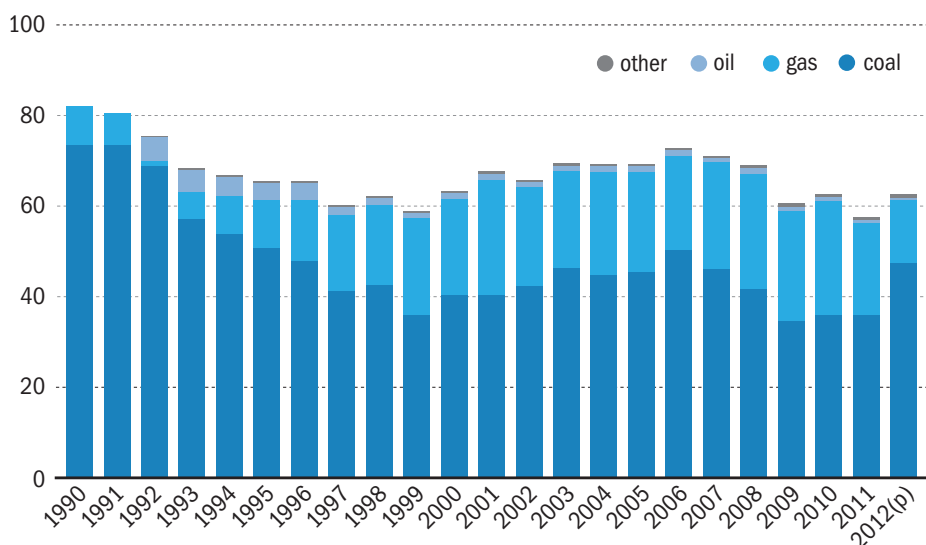

threat to the business interests of the international oil companies. Those companies have shown an ability to alter the balance of their activities (eg, increasing interest in natural gas). Liquefied natural gas (LNG) in particular has potential synergies with future hydrogen economy, but even more generally, hydrogen represents a much more natural energy

sector for the international oil companies than any move into the electricity for transport business.

This report has been prepared to stress the potential synergies between physics and the future of hydrogen. Less physics-specific forward looks have been provided by others in the spirit of “foresight” [3] [4].

UK petrol and diesel prices, deflated using GDP (market prices) deflator 2005 = 100.
Source: National Statistics (and DECC), UK Energy in Brief 2013

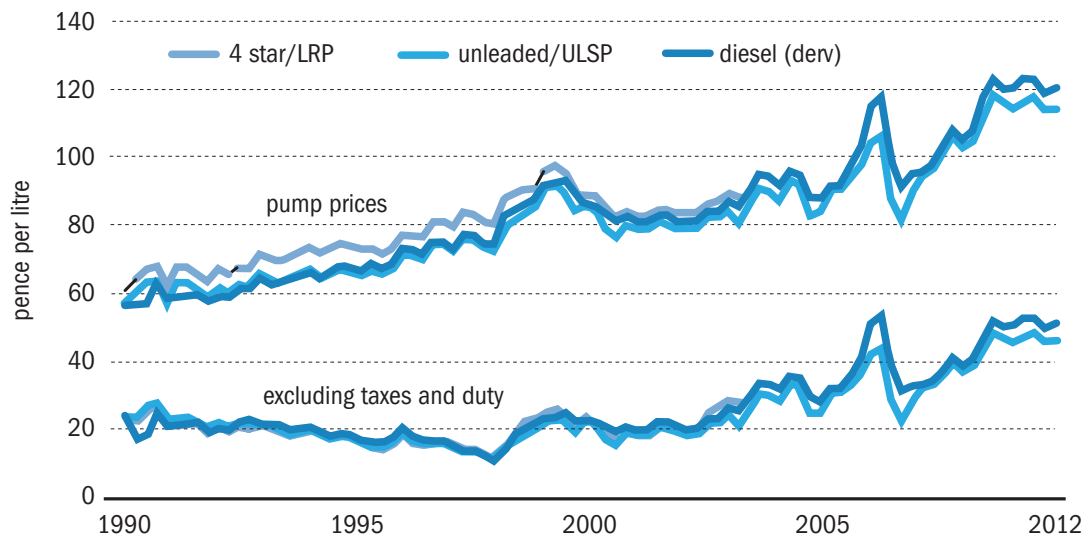

Predicted global battery electric vehicle (BEV), plug-in hybrid electric vehicle (PHEV) and hybrid electric vehicle (HEV) car sales. Source: Pike Research, Predicted Global Electric and Hybrid Car Sales, reported by Green Car Reports

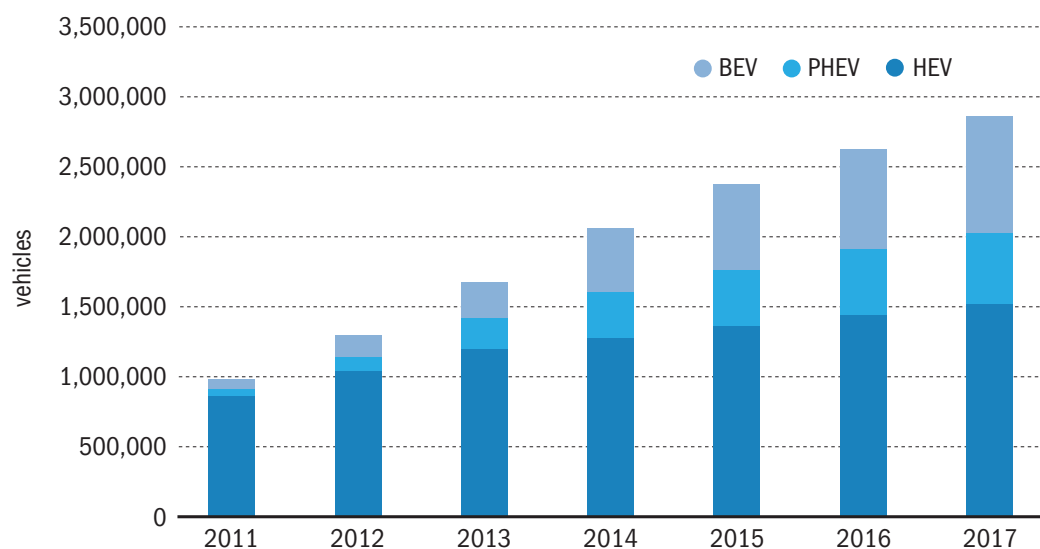

Physicists and hydrogen

The early science of hydrogen was essentially chemistry. The very name hydrogen refers to its chemistry: when hydrogen is combusted, water is formed, hence “hydrogen” (water generator). Hydrogen production by simple chemical reactions has now been known for half a millennium but the identification of hydrogen as a single substance dates from the late 18th century and the work of Henry Cavendish, who was both a chemist and a physicist. Physicists’ interest in the gas grew through the 19th century as it became clear that it is the simplest of all chemical elements and, as spectroscopy revealed, it is also the most abundant element in the universe. Physicists, from cosmologists to those concerned with quantum

mechanics at the smallest length scales, have given much attention to hydrogen. Indeed, the Schrödinger equation of quantum mechanics has only been used successfully to fully understand one atom – the simplest of them all, hydrogen.

As the next section will make clear, engineers have also been much concerned with hydrogen for many years. Hydrogen has a major role in modern chemical engineering. In this report, the focus is on the technological potential of hydrogen in the future and as such, it will span from science to engineering, but in the process particular emphasis will be given to the current and future input of physics.

Current use of hydrogen

For 2010, global hydrogen production has been estimated to be 53 million tonnes and this was expected to grow by an average of 5.6% in the following years [5]. Hydrogen applications relate to its role as a chemical feedstock.

Texas-based consultants MarketandMarket anticipate that the drivers for increased hydrogen production will continue to be: regulations requiring lower sulphur levels in petroleum products, the need to process crude oils of decreasing quality, and the search of cleaner fuel options [5].

Furthermore, the company notes that: “merchant hydrogen production is a small segment but will be the fastest growing segment in the future. At present it accounts for only 12% of total on-purpose hydrogen generation but this share is estimated to increase up to 16% by 2016.”

Global hydrogen use (2003). Source: Argonne National Lab, Decision and Information Sciences

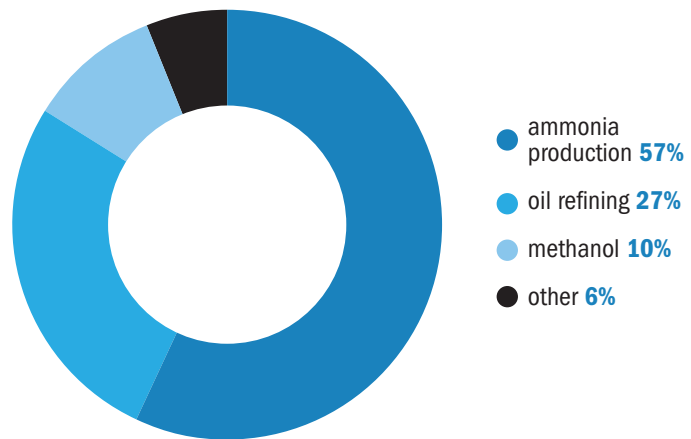

Journey to the hydrogen economy

While there are various near-term intermediate states on the path to a hydrogen economy, the long-term state of that economy is not obvious. These issues were summarised by William McDowall and Malcolm Eames in 2006 [6]. These ideas were also considered by Joan Ogden in the same year [7].

There are many possible paths to a future hydrogen economy, but as McDowall and Eames observe there are significant barriers to development in “business as usual” scenarios. In most cases, significant technology policy will be required.

The various scenario ideas each represent a

Hydrogen near term. Source: Scientific American, High Hopes for Hydrogen, Joan Ogden, September 2006, artwork Don Foley

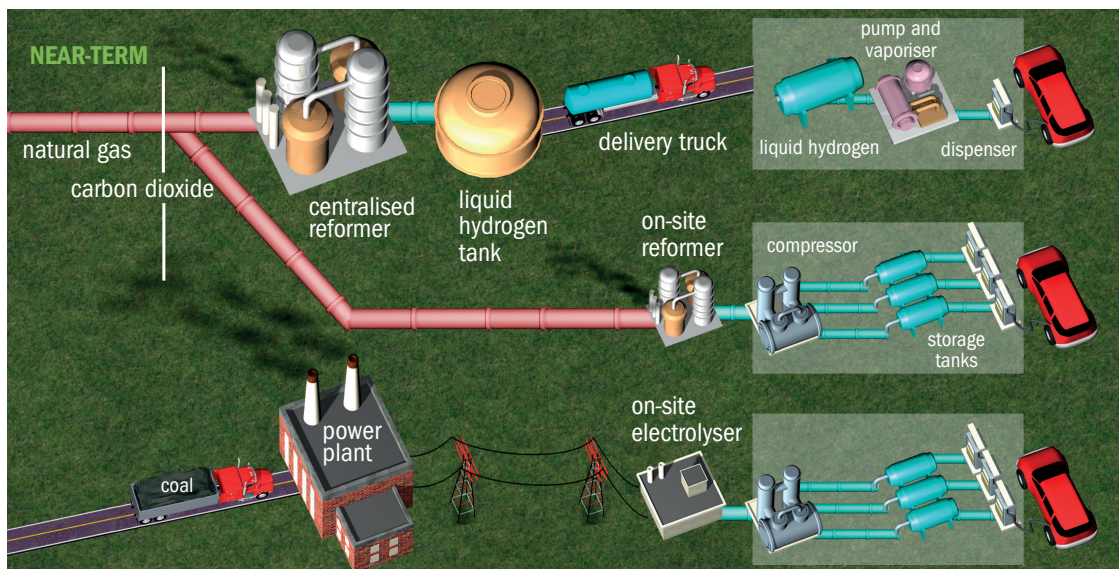

Hydrogen long term. Source: Scientific American, High Hopes for Hydrogen, Joan Ogden, September 2006, artwork Don Foley

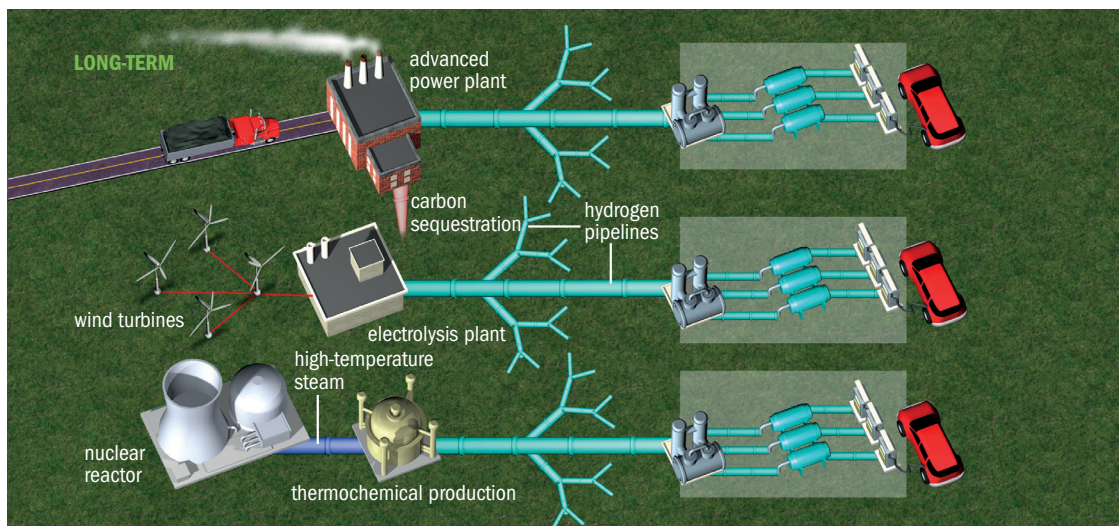

means by which a ubiquitous hydrogen economy might be achieved, and as such have a potential role as intermediate states of an evolving system. While there may be beneficial synergies between these intermediate states, to some extent they compete with one another for limited research, development, demonstration and deployment resources. The various intermediate states may be distinguished by considering that they involve the following choices:

- Local distributed small-scale versus centralised large-scale generation
- Supportive to, or undermining of, existing fossil-fuel industry incumbents
- Based on gaseous hydrogen or cryogenic liquid hydrogen

All of these choices and options involve physics and physicists. In each case, of course, the physics perspective is merely one aspect of a multi-disciplinary challenge. That said, one issue in particular brings out especially rich physics-based considerations – the potential use of cryogenic liquid hydrogen. For that reason, and also because it represents one of the more readily achieved intermediate system states, it is given prominence in this report.

Hydrogen as a vehicle fuel

Importantly, much attention has been, and continues to be, given to hydrogen as an energy carrier for vehicular fuel-cell-based applications. In Germany, the H2-Mobility consortium has envisaged the construction of 1,000 fuelling stations for hydrogen-fuelled vehicles by 2030 and Norway currently has fuelling stations in operation along the country in which vehicles can be fuelled and run off hydrogen. The use of hydrogen in transport is increasing and this trend can be expected to continue.

In the UK, Scotland announced plans in 2009 for a hydrogen corridor that will travel from Aberdeen to Inverness [8]. The Scottish government says that it seeks to build a sustainable economy based on the use of renewable energy and hydrogen technologies. England is also taking steps with pilot infrastructures being proposed for the refuelling of road vehicles.

One should not fall into the trap of assuming that necessarily the most important innovations

will emerge from such planned pathways. In a global economy, innovation may come from anywhere and occur in both business models and technologies. In the technology space, one can see that advanced fuel-cell technologies, such as polymeric systems, might appear more attractive than solid-oxide systems, but they currently require relatively high levels of hydrogen purity. Hydrogen purity is one important consideration affecting the relative attractiveness of different hydrogen fuel-cell technology options. These issues will be considered further in the next section.

Hydrogen fuel-cell technology

Fuel cells convert chemical energy into electrical energy. Unlike a battery, which stores electrical charge, a fuel cell is fed with fuels that it converts in an electro-chemical reaction into useful direct-current electricity. The fuel cell will run for as long as it is supplied with fuels of sufficient purity and cleanliness. Fuel-cell technologies of various types have differing abilities to cope with low-purity fuel.

One of the most established fuel technologies is the solid oxide fuel cell (SOFC) as this has the ability to cope with fuels of relatively low quality. Such systems make use of a solid oxide as the electrolyte. In some cases, this electrolyte is a ceramic. The fuels must migrate through the solid electrolyte and this is one reason that SOFCs must operate at a high temperature (in excess of 600 °C). This in turn is one reason for slow start-up of such systems. This attribute of SOFCs tends to favour the use of the technology in stationary applications. In addition, exothermic reaction heat can be used to support endothermic solid oxide fuel-assisted electrolysis cells in a hybrid stack, enhancing overall efficiency via the co-generation of hydrogen and electricity [9]. Notwithstanding the start-up issue, fuel-cell systems operating at elevated temperatures could easily address an important issue for future vehicles – passenger compartment heating [10]. For electric vehicles this is a particular problem owing to the high energy demands associated with air heating. One solution is to make the air volume, and hence the compartment size, smaller in such cars. As heating is relatively straightforward for hydrogen-fuelled cars they can arguably more easily resemble traditional vehicle shapes and structures. Even in those cases where a polymeric low-temperature fuel

5: Journey to the hydrogen economy

cell is deployed, small amounts of hydrogen could be safely diverted for passenger cabin heating.

One low-temperature fuel-cell option is a proton exchange membrane (PEM) fuel cell. This technology has the potential to be an extremely efficient hydrogen energy converter. Tremendous effort has been made in the past decade to develop materials suitable for PEM fuel cells and to meet the different technology policy targets set by the US, the UK and the EU.

Generally, hydrogen-based fuel cells have many advantages such as high electrical efficiencies, zero or low emissions, less noise pollution, good reliability, and no need for moving parts in the energy converter. Such systems are well suited to remote and unattended operations. Thanks to these advantages, fuel cells are being developed for numerous commercial and military applications, such as automobiles, portable electronic devices, and mobile and stationary power generation. Other low-temperature fuel cells, such as phosphoric acid fuel cells, proton-exchange membrane fuel cell and direct methanol fuel cells are attractive innovations now becoming close to commercial application.

The heart of a low temperature fuel cell (LTFC) is a membrane-electrode assembly, which is a layered structure comprising a proton conductive polymer, electro-catalysts and gas diffusion layers (GDLs). The GDLs are bonded to the opposite sides of the

conductive polymer and act as both an anode and a cathode. In LTFC systems, the electro-catalysts are normally made of platinum, which is expensive. The high cost provides commercial pressure to reduce platinum loading, which is achieved by utilising tiny platinum particles dispersed evenly and maximising the contact with the proton conductive polymer membrane. Such dispersion is made possible by depositing platinum catalysts on a carbon support.

Hydrogen vehicle refuelling

Electric vehicle technologies are known for the problems associated with slow recharging. While traditional fossil-fuelled vehicles can be refuelled in a matter of minutes at a filling station, an electric vehicle cannot easily be recharged so quickly. While quick battery swaps have been suggested, perhaps on the back of battery leasing rather than ownership, the dominant paradigm for electric vehicles has become overnight electric charging at home. While this gives consumers the significant benefit of using low-tax domestic electricity, as opposed to highly taxed petroleum products, slow recharging brings inconvenience to the vehicle owner, or at least the need to adjust to altered realities surrounding refuelling. The benefits for electricity system management arising from controlled or incentivised off-peak vehicle charging were mentioned earlier.

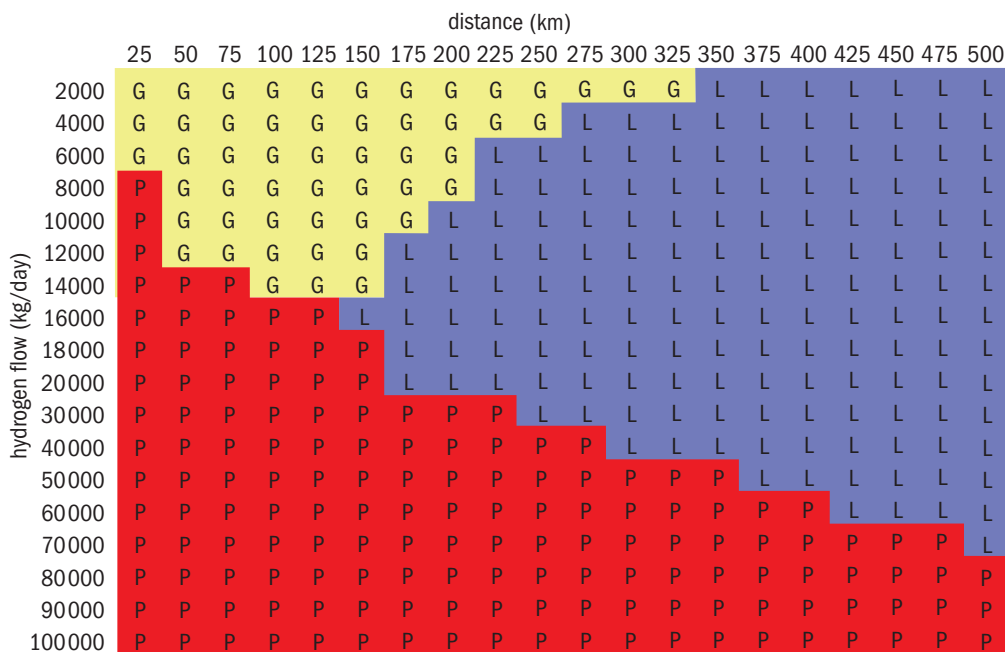

Mode map of the lowest cost hydrogen delivery options as a function of hydrogen flow and transport distance: G – compress gas truck, L – liquid track, P – pipeline. Source: Christopher Yang and Joan Ogden, Determining the lowest-cost hydrogen delivery mode, International Journal of Hydrogen Energy 32 (2007)

5: Journey to the hydrogen economy

In principle, hydrogen vehicles hold open the possibility of rapid refuelling in a manner that, for the customer at least, is very similar to traditional vehicle refuelling. How important this is, remains to be seen. Currently, most privately owned electric vehicles belong to enthusiastic early adopters.

In the case of hydrogen-fuelled vehicles there is a challenge in ensuring access to fuel irrespective of whether liquid hydrogen or compressed hydrogen gas is used to provide the energy source to vehicles and also irrespective of whether the vehicle is fuel-cell- or combustion-engine-based. Generally, the requirement for hydrogen in a fuel-cell-powered electric car will be more modest than for an equivalent combustion engine. It is noteworthy that a modern car optimised for mobility rather than prestige, has a range of 400 km burning about 24 kg of petrol in its combustion engine. To cover the same range in a hydrogen-fuelled vehicle, 8 kg of hydrogen would be needed for a combustion engine version, or just 4 kg for a fuel-cell car. While the masses of hydrogen are impressively low, one must not forget the relatively low density of liquid hydrogen and the very low density of even high-pressure gas. It is not the mass of the fuel, but the size of the tank that motivates the technological challenges.

The answer to the fuel supply challenge is not immediately obvious, as it refers to whole system design choices including the generation and the distribution of the hydrogen. If the hydrogen is not produced locally, then it needs to be delivered from a large production plant as a cryogenic liquid, or high-pressure gas by truck, or as a gas through a pipeline. The economics of delivery is very much dictated by the distance and required capacity of demand.

For various scenarios of low-hydrogen flow rate and short transport distances the least cost pathway for production, storage and distribution of hydrogen is as a compressed gas. If on the other hand the hydrogen is generated locally via electrolysis or methane plasma splitting, or reforming using available electricity from the power grid, then there is a different story. At larger scales of production, liquid hydrogen becomes more attractive.

An example of the 700 bar gas hydrogen powered Hyundai ix35 fuel-cell car. Source: authors



700 bar hydrogen gas

The Norwegian compressed-gas hydrogen vehicle initiative provides a network of the compressed H₂ gas fuelling stations across Norway using local electrolyzers and compressors. The initiative generates and transfers 700 bar gas. Initially, the gas is being used to fuel the Hyundai ix35 fuel-cell car. The initiative demonstrates the benefits of hydrogen fuel-cell technology and also shows that high-pressure hydrogen can be used safely by the public.

Refuelling – technologies and practicalities

The refuelling of the cars by hydrogen in public places potentially poses risks arising from the mishandling of the hydrogen transfer to the vehicle. There are essentially two ways to transfer hydrogen: either as a liquid or as a compressed gas. Both technologies are now mature and have been deployed. The liquid hydrogen approach requires more highly specialised equipment. Such technology has been patented and, as such, deployment will rely on appropriate intellectual property licensing.

Significant research and development into cryogenic technologies has led to the manufacture of second-generation cryo-compressed hydrogen tanks for vehicle applications. These new tanks are characterised by very low boil-off as well as improved security in the scenario that the last liquid hydrogen has vaporised. In such a scenario, the tank supplies 300 bar gaseous hydrogen.

5: Journey to the hydrogen economy

Left – a patented liquid-hydrogen fuelling nozzle developed by Linde-BMW; right – a more conventional gas transfer coupler. Source: Air Products



Comparison of cryogenic-hydrogen vehicle storage with more conventional compressed-gas storage. Source: BMW Hydrogen Storage Workshop (<http://tinyurl.com/BMWHydrogenStorage>)

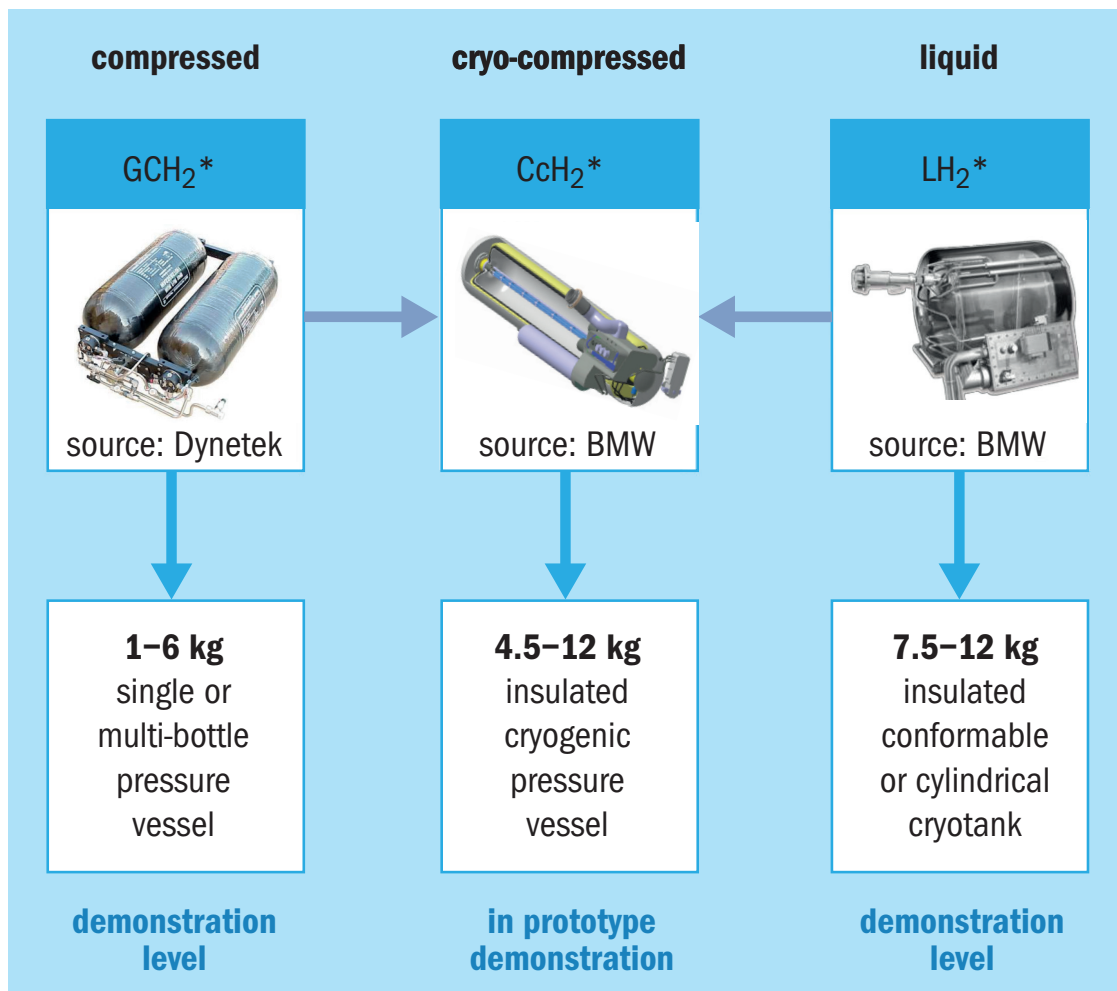

Role of nanostructures and adsorption

In contrast to physical storage of compressed gas and cryogenic liquid hydrogen there are also a variety of solid-state approaches including metallic, chemical and organic hydrides, as well as storage approaches based on adsorption. Adsorption storage can be based on: activated carbon nanoforms, metal-organic frameworks or zeolites. It is important to realise that while solid-state storage technologies are very interesting and hold out much promise for better and safer storage, they are currently at the research level and no existing solid storage system yet fulfills all automotive requirements.

Hydrogen and the electricity system

Hydrogen has an important role in today's thermal generation of electricity from fossil fuels or nuclear energy. Hydrogen gas is used to cool the turbo generators of today's large power stations. Looking to the future, advanced fossil-fuel power generators such as integrated gasification combined-cycle technologies and modular membrane reactors can be expected to make much use of hydrogen either alone or as part of a synthetic fuel or syngas [11].

Noting the potential for future surplus renewable electrical energy, interest has been growing in energy storage via hydrogen. Such ideas form part of a wider technological vision known as "Power to Gas". This could involve a range of syngases produced with the assistance of abundant electricity and possibly fed into the existing natural gas distribution grid, rather than reconverted back to power. As regards the importance of renewable energy storage we note the work of Grunewald et al [12]. Future electricity storage involves meeting two rather separate challenges – the easier is night-to-day storage (taking surplus power from the early morning and storing it for use in the following early evening) and, for countries such as the UK, the more challenging goal of summer-to-winter storage. The peak of Britain's electricity use is on cold dark early evenings in winter.

Hydrogen production and delivery

Research Councils UK has funded a large-scale collaborative research programme between British universities, funded through the RCUK Supergen programme. The focus of that research has been to

focus on the potential for widely distributed local hydrogen production involving therefore mainly smaller-scale technologies.

The potential availability in the future of low-cost, otherwise surplus, renewable electricity, greatly favours arguments for the electrolysis of water, which otherwise appears to be economically disfavoured. Electrolysis can be performed via a range of technological approaches and high-temperature steam electrolysis appears most attractive. The approach has been considered by George Tsekouras and John Irvine as part of their work for the DoSH₂ consortium. Their activities are complemented by the work of Andrew Cruden elsewhere in the same consortium [13].

As concerns local small-scale distributed hydrogen production, the dominant approaches are electrolysis and the more efficient, but usually CO₂ emitting, process of high-temperature electrolysis. In such systems, energy distribution is primarily achieved via electricity grids supplying power to local electrolysis facilities that might be located at filling stations linked to petroleum product distribution. This scenario is easily consistent with the need to make use of renewable electricity in times of surplus and the very low (or even negative) electricity prices that can be expected in the future to assist the economics. Noting, however, that other responses will be occurring to change intermittently low electricity prices, there are risks to investors. Costs are also a concern at a total energy system level and such aspects should be considered.

In South Africa, Rand Technical Services has collaborated with NEL Hydrogen to produce a small hydrogen electrolyser with a view to achieving mass-market affordability. The emergent product is the NEL P-60 [14].

In Denmark, the pan-European BioCat consortium has started work on a 1 MW power-to-gas demonstration project aiming to make use of surplus renewable electricity [15]. The project will deploy water electrolysis to make hydrogen that in turn is used to make methane in a bioreactor via the action of microorganisms. The resulting natural gas is then to be supplied to consumers in the greater Copenhagen area using the standard gas distribution grid. Such power-to-gas schemes generally rely on free surplus electricity (or even electricity at negative prices) in order to develop

5: Journey to the hydrogen economy

Smart nano-materials for hydrogen-based fuel cells

A number of novel high surface area carbon materials are being investigated as alternative support materials for precious metal catalysts in proton exchange membrane (PEM) fuel cells. Examples of candidate materials include mesoporous carbon, carbon nanotubes, carbon nanohorns, carbon nanocoils, graphitic carbon and graphitic nanofibres. Nano-materials (ie, materials with structural dimensions measured in the nanometre scale) have the potential to play a significant role in the production, diffusion and conversion of hydrogen. Among the various candidate PEM support materials, “few layer graphene nanoplatelet” technology (GnP) has the potential to be one of the most cost-effective options. GnP also has excellent mechanical and electrical properties relative to carbon nanotubes or more conventional “carbon-black” material. Carbon-black is a form of soot formed naturally and without any control of its nanostructure.

Few layer graphene nanoplatelets technology can be useful in electrodes for low-temperature PEM hydrogen-based fuel cells. Together with nano-structured carbon, GnP brings the benefit of increased catalytic activity, large specific surface area, minimal

transport limitations of reactants and products, high electrical conductivity and improved chemical stability. In short, nano-structured particles offer many advantages over unstructured alternatives.

Recent achievements by various research groups have resulted in two breakthrough processes: the first is the capability to produce exfoliated graphite (graphene) nanoplatelets (GnP), which have superior mechanical, electrical, and thermal properties, and all at remarkably low cost; the second development has been the discovery of a new fast and efficient process to generate nanoparticles from a variety of metal, metal oxide and semiconductor compositions ranging from 1–10 nm in diameter. The combination of these technologies has resulted in the ability to deposit and coat GnP with very fine nanoparticles at up to 70 wt% loading. This innovation is versatile enough to synthesise any metal, metal oxide or semiconductor into nanoparticles less than 5 nm in diameter and simultaneously to attach them to the surface of GnP. There is now a simple and fast one-step process with the potential to improve greatly hydrogen conversion and reactivity.

Metal nano-coated particles of GnP potentially possess superior characteristics for batteries, fuel cells and catalytic converter applications. They bring excellent electrical conductivity, superior corrosion resistance, higher surface to volume ratios, higher catalyst accessibility, higher aspect ratios, higher mechanical strength, lower impurity levels, and higher degrees of graphitisation making them a preferable candidate for fuel cells.

It appears that the production of metal nanoparticles with a very narrow size distribution could be key to the success of hydrogen PEM-based fuel cells. Platinum particles synthesised by conventional methods are large with very wide size distributions. They exist in large agglomerated network structures, which is not desirable for practical applications. However, the nano-synthesis method produces smaller and more uniform particles with a much narrower size distribution and without any agglomeration. This method has also been applied successfully in the synthesis of other nano-sized metal particles such as Os, Ni, Ru, Au, Pd and Sn, again with very narrow size distributions.

a viable business model. Whether such low input prices can be assumed for the long-term in the face of a growing range of electricity storage options remains to be seen. Also, there continues to be much uncertainty about future prices of European natural gas. Even if shale gas innovations remain barred in several EU member states, the EU will not be insulated from falling natural gas prices globally, especially if the US, as expected, moves into becoming a significant LNG exporter.

In 2010, Paul Ekins summarised the costs of competing approaches to hydrogen production. Ekins and co-workers did not consider various

advanced approaches that remain to be demonstrated at commercial scale [16]. One such approach is the biological approach being adopted by BioCat in Denmark. Another advanced approach is the use of thermo-chemical approaches at high temperature. Such approaches include the sulphur-iodine cycle (S-I) requiring temperatures of 750 °C and above. That approach has been studied at laboratory scale by General Atomics of San Diego and others [17]. The process splits water directly but avoids the need for electricity. The process represents somewhat challenging chemical engineering requiring the use of high-temperature

Costs of hydrogen production. Based on work of Ekins et al [16]

Technology	Cost range US\$(2000) per GJ of H ₂	Note
Large-scale steam reforming (>1000 MW)	5.25–7.26	For steam reforming natural gas price is a key consideration
Small-scale steam reforming (<5 MW)	11.50–40.40	Smaller scale, higher cost
Coal gasification (min. 376 MW)	5.40–6.80	CO ₂ capture would add 11% to costs
Biomass gasification (>10 MW)	7.54–32.61	Average cost 14.31
Biomass pyrolysis (>10 MW)	6.19– 14.98	Cost reduced by sale of co-products
Large-scale electrolysis (>1 MW)	11–75	Cost of electricity is a key consideration
Small-scale electrolysis (<1 MW)	28–133	Cost is highly size dependent – smaller scale, higher cost

concentrated sulphuric acid and hydrogen iodide. The S–I cycle requires a good source of process heat at high temperature. One such source that has received much consideration is nuclear fission and the possible use of S-I has been one motivation for the proposed Very High Temperature Reactor. One problem, however, has been to identify suitable engineering materials able to cope under load with temperatures around 1000 °C for decades. Conventional steels suffer badly from creep and other sources of structural weakness at such temperatures. In recent years, ambition for the VHTR concept has been scaled back somewhat (to approximately 750 °C).

Hydrogen storage

Conventional options for hydrogen storage include compressed gas, use of a chemical compound or “syn-fuel”, adsorption on special substrates or within nanoscale structures or cryogenic liquid hydrogen. Given the strong links to physics and physics-based technologies, this report gives emphasis to adsorption and the potential use of liquid-hydrogen-based storage.

Hydrogen demand today

As noted earlier, demand for hydrogen is currently dominated by the chemical process industries. For example, oil refineries are major users of

hydrogen. The driver for this has been regulatory pressure to remove impurities such as sulphur, olefins and aromatics from refined product, and competitive pressures to improve combustion efficiency in vehicle engines [18]. Refineries operate continuously and require a reliable supply of hydrogen. Failure of hydrogen availability could be profoundly disruptive and expensive throughout the petroleum supply chain. Hydrogen supply problems have the power to disrupt the very large international oil business. In the early 1990s there was a shift among refiners towards outsourcing hydrogen supply to specialist industrial gas companies rather than to seek to make hydrogen in-house. Today, refinery operations in India, China and the Middle East represent major markets for companies selling hydrogen services [18].

One industrial gases company, Air Products, has developed a major hydrogen pipeline serving the Gulf of Mexico. It stretches from the Houston Ship Channel in Texas to New Orleans, Louisiana. The Gulf Coast Connection Pipeline can supply more than 1.2 billion cubic feet of gaseous hydrogen per day to customers along the 600-mile pipeline. The pipeline is fed by more than 20 hydrogen production facilities. This infrastructure greatly increases system security and reliability for the major refinery operations located along the Gulf Coast [18].

5: Journey to the hydrogen economy

Status of various hydrogen storage technologies in 2008 compared to US policy goals for 2010.
Source: Sunita Satyapal, US Department of Energy, Hydrogen and Fuel Cells Program, 2008 Annual Progress Report Section IV

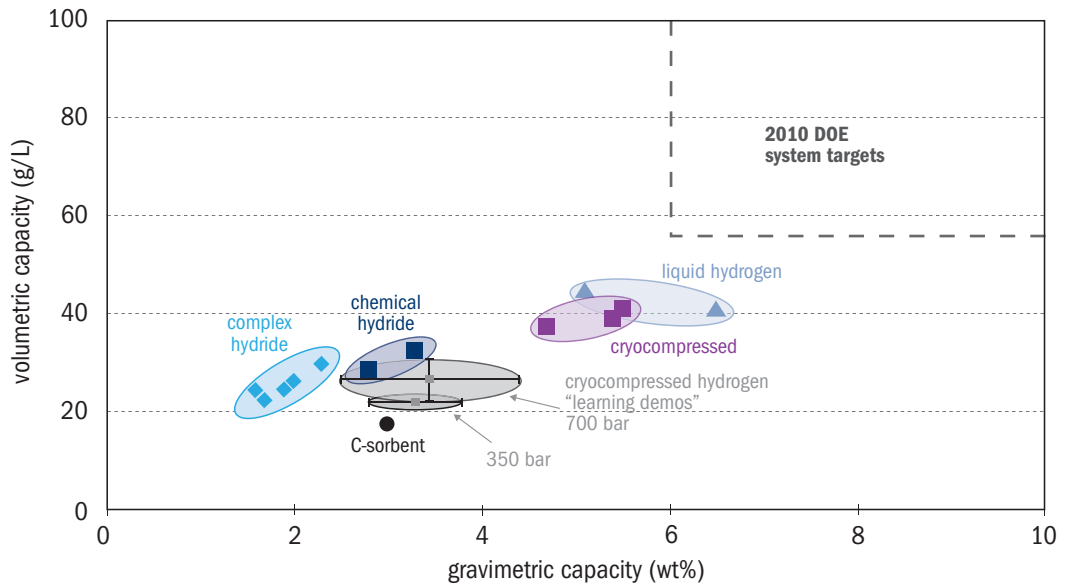

Several industrial gases companies are fuelling captive forklift fleets with hydrogen. The example opposite comes from Linde AG

Fuel-cell forklift trucks

A case study

The technology transition to hydrogen-fuelled personal mobility is a complex issue beset by numerous obstacles and bottlenecks associated with the co-development of public infrastructures and privately owned vehicles. Captive fleets of vehicles represent an easier first application of hydrogen fuel. One such example would be an urban passenger bus fleet and such ideas have been the subject of much research and development. Such approaches face aggressive competition from electric-battery technologies and novel fossil fuels

as well as hybrid technologies [B1]. Another good example of a captive fleet is forklift trucks in a major warehouse or logistics hub. The industrial gases company Air Liquide has given much attention to this market opportunity. Chief Executive Eric Prades has noted that: the conversion of just 10% of the worldwide forklift fleet to hydrogen fuel would represent a market of €7 bn in fuel cells and hydrogen [B2]. He notes that already more than 4,000 forklift trucks are running on hydrogen in North America. In Europe, Air Liquide and Plug Power are collaborating in a new venture: HyPulsion for hydrogen-fuelled

forklifts. The furniture and homewares retailer IKEA has been an early customer deploying the technology in its 100,000 m² distribution centre near Lyon, France. HyPulsion plans to have 84 hydrogen-fuelled forklifts operating on site with Air Liquide supplying a hydrogen-filling station capable of meeting a demand for 50 tons of hydrogen per year.

Forklift trucks represent a good early demonstration of the potential for hydrogen fuelling as the technology requirements are demanding, noting for instance that a forklift can be expected to be used three times more intensively than the average car on the road.

Cryogenic liquid hydrogen

In this report, particular attention is paid to one pathway to a future hydrogen economy – the cryogenic liquid hydrogen route. This approach is taken because of the strong role of physics in such ideas and also because the authors believe it to be the path that is most accessible in business-as-usual scenarios, and hence requires the least policy intervention. One can envisage this pathway being led not by major energy companies in the first instance, but rather by the industrial gases industry.

McDowall and Eames have considered eight visions of the way ahead [3]. The liquid hydrogen option is merely one of those eight. They summarise that vision with the graphic shown below.

A liquid-hydrogen-based hydrogen economy in the UK has also been considered by Balta-Ozkan and Strachan [19]. They see a future in which liquid-hydrogen infrastructure is based on large-scale centralised production, with relatively long distribution distances matching to clustered demand points. The authors concur that (in the absence of the cryogenic benefits discussed in the next section) the most attractive application of hydrogen liquefaction is associated with large-scale producers. This centralisation and clustering is a way to achieve the necessary economies of scale.

The attributes of liquid hydrogen

To exist as a liquid, H_2 must be cooled below hydrogen's critical point of 33 K ($-240\text{ }^\circ\text{C}$). The critical point is a set of ambient parameters (including temperature) above which the fluid phase shows no clear distinction between gas and liquid. However, for hydrogen to be in a full liquid state without vaporising at atmospheric pressure, it needs to be cooled to 20.3 K. The melting point of hydrogen is relatively close by at 14.0 K. Liquid hydrogen has a set of important attributes. It has low viscosity and has a low molecular weight. It has high thermal conductivity and a very high heat of vaporisation. These attributes favour the use of hydrogen as a cryogenic coolant in comparison with other low-temperature cryogenic liquids such as helium and neon. The future price and availability of helium for cryogenic applications has been an issue of growing concern in recent years [20].

Hydrogen cryogenics can be combined with helium in an indirect cooling scheme [21]. In such a scheme, 20 K gaseous helium is in thermal equilibrium with liquid hydrogen. The cooling of critical components is achieved using 20 K helium (permitting high-system pressures, ensuring high heat-transfer rates and protecting against safety risks and solid-phase blockages [22]). An excellent example of the superior efficiency of the liquid

Schematic vision of a liquid-hydrogen-based hydrogen economy in the UK. Source: W McDowall and M Eames, *Int. J. Hydrogen Energy* 2007, 32, Issue 18, December 2007

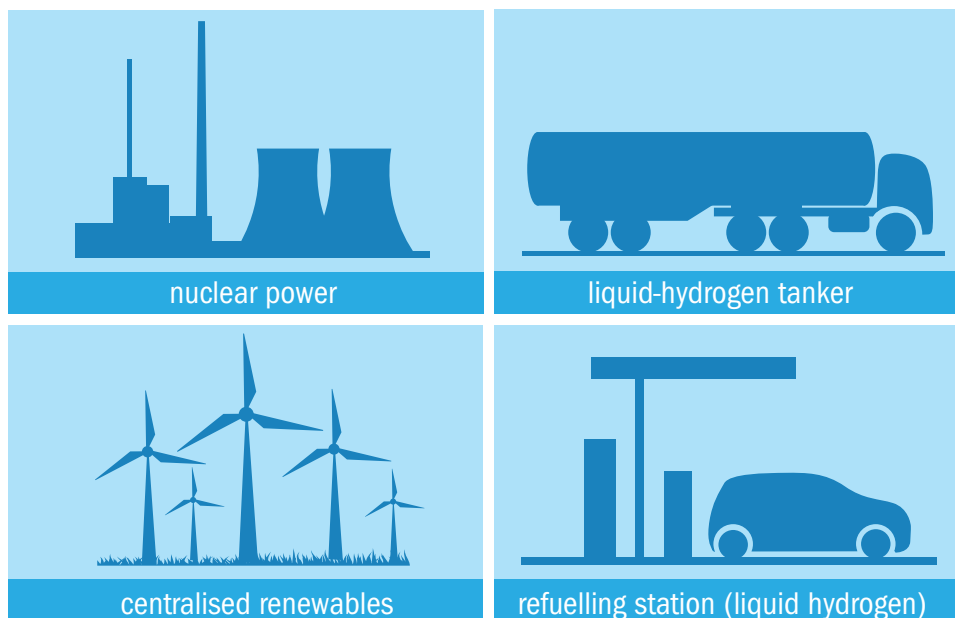

6: Cryogenic liquid hydrogen

hydrogen indirect cooling over the liquid helium and liquid neon cooling has been demonstrated by McDonald et al in a 15 Tesla pulsed non-superconducting copper solenoid magnet at the CERN Laboratory [23].

The liquefaction of cryogenic gases requires significant energy. When considering the joint attributes of liquid hydrogen as an energy carrier and as a coolant, it is important to understand what proportion of the energy embodied in the original gaseous hydrogen would be required to cool that hydrogen into the liquid state. In large-scale liquid-hydrogen production (eg quantities of ~10,000 kg/h), the process of liquefaction requires energy equivalent to roughly 30% of the higher heating value of the hydrogen. While this might appear to represent a significant process inefficiency, converting hydrogen into the more energy-dense liquid state, and into a state that has cryogenic utility, can actually be very valuable. If, by way of contrast, one considers small-scale hydrogen liquefaction (eg approaching 1 kg/h) then even with advanced liquefaction systems, the energy required for liquefaction is equal to the energy carried by the hydrogen itself and that motivates our earlier observations in favour of linkage to large-scale production. Indeed, such realities very often underpin arguments against small-scale hydrogen liquefaction. It is clear that cryogenic liquid hydrogen is best suited to those visions of the hydrogen economy emphasising large-scale centralised production. In such large-scale production scenarios tanker-truck liquid-hydrogen distribution must be compared with gaseous hydrogen supply chains that may at such scales involve pipelines.

UK liquid-hydrogen infrastructures 2050 – a scenario.

Source: N Balta-Ozkan and N Strachan, Hydrogen System Modelling, in Hydrogen Energy, Ed. Paul Ekins, Earthscan (2010)

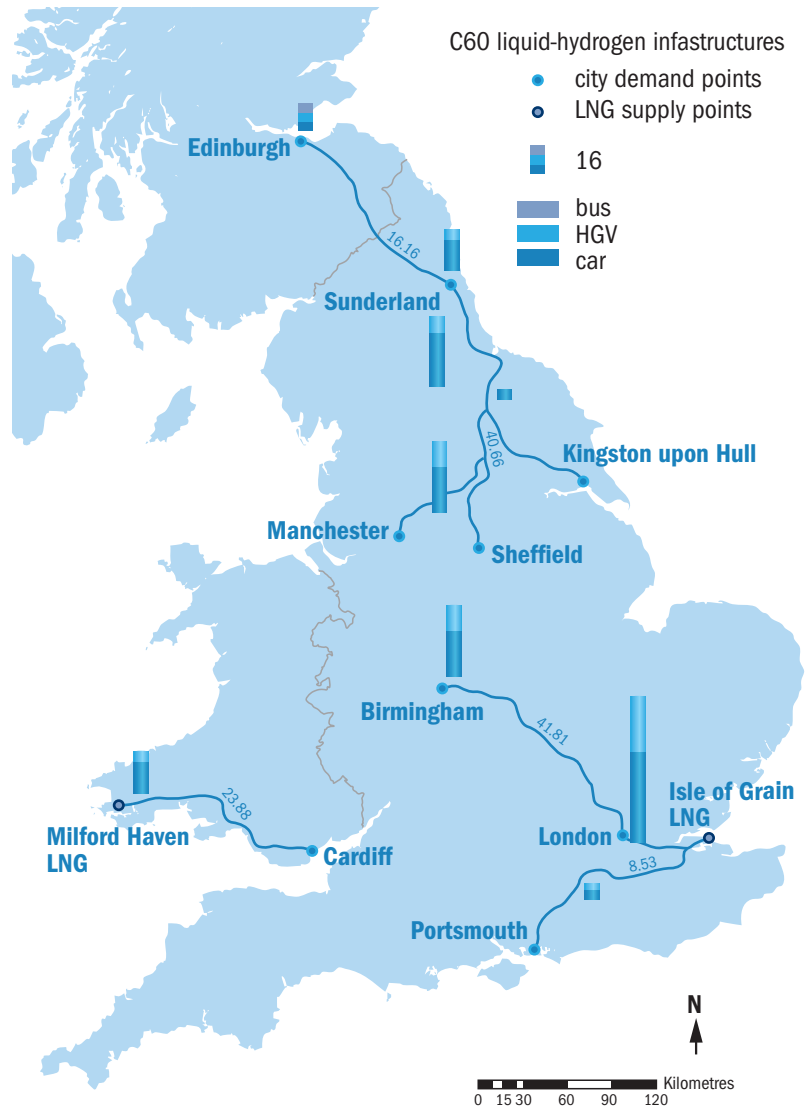

6: Cryogenic liquid hydrogen

Lower-cost hydrogen cryogenics

We present a calculation and data illustrating the cost advantages of moving from liquid-helium cooling of magnets to liquid-hydrogen cooling. In this example we consider the 15 T pulsed non-superconducting magnet referred to in the main text.

Considering the attributes of indirect cooling mentioned in the main text, we introduce a quality factor Q for the refrigeration of the circulating gaseous cryogen drawing upon liquid-cryogen consumption (boiling in the heat exchanger). Q may be defined by:

$$Q \text{ (kJ/\$US)} = \Delta H_v \cdot \rho_L \cdot (1 \text{ m}^3/1000 \text{ litre}) \cdot (\text{litre}/\$US) \text{ where } \Delta H_v \text{ is the heat of vaporisation and } \rho_L \text{ is density.}$$

Q is measured in kJ of heat-of-vaporization/\\$US at normal boiling point temperature.

Relevant Q values are given below. Considering the case of the 15 T magnet: about 18 MJ = 18,000 kJ of energy is generated. The estimated cost for cooling one magnetic pulse can be calculated for different main cryogenics:

$$LH_2 \text{ cooling cost} = 18,000/Q = \$300 \text{ per pulse}$$

$$LHe \text{ cooling cost} = (60/0.85) \cdot (LH_2 \text{ cooling cost}) = \$21,000 \text{ per pulse}$$

$$LNe \text{ cooling cost} = (60/0.60) \cdot (LH_2 \text{ cooling cost}) = \$30,000 \text{ per pulse}$$

Cryogenics with a normal boiling point (NBP) below 30 K, ρ_L , ρ_v and ρ_g associated with density refer to liquid and vapour at T_{NBP} , while ρ_g refers to values taken at 0 °C. The Vaporisation index (VI) = $10^3 \cdot (300 - T_{NBP}) / (\rho_L \cdot \Delta H_v)$, where ρ is density and ΔH_v is the heat of vaporisation [C1]

Fluid	MW	T_{NBP}	ρ_L	ρ_v	ρ_g	ΔH_v	V_w/V_L	V_g/V_L	VI
		K	kg/m ³	kg/m ³	kg/m ³	kJ/kg			K*cm ³ /J
He	4.003	4.2	124.9	16.9	0.178	20.3	7.4	701	117
H ₂	2.016	20.3	70.8	1.34	0.0899	446	52.8	788	8.9
Ne	20.18	27.1	1207	9.58	0.9	85.8	126	1341	2.6

Quality value Q , based on refrigeration/cost at T_{NBP} for the three cryogenics considered in the table above. The costs are representative of the year 2002 [C1]

Fluid	T_{NBP}	ΔH_v	ρ_L	Cost	Q
	K	kJ/kg	kg/m ³	\\$US/litre	kJ/\\$US
He	4.2	20.3	124.9	3	0.85
H ₂	20.3	446	70.8	0.53	59.58
Ne	27.1	85.8	1207	173	0.6

Hydrogen liquefaction in practice

A hydrogen-liquefaction system has been developed by Linde-Hampson and is presented schematically in the figure below. Pure hydrogen enters the cycle at point 1 and is compressed at point 2 by a hydrogen compressor (H2COM). In HX1, cold gases (nitrogen and helium) together with cold return hydrogen pre-cool the high-pressure hydrogen stream before it enters the liquid-nitrogen bath. This bath removes heat from the hydrogen and cools it down to an intermediate temperature at point 3. The pre-cooled compressed hydrogen stream then flows through the hydrogen-hydrogen heat exchanger HX2 connected to the returning cold H₂ stream. In this way, the compressed stream is reduced at point 4 to the final temperature. Finally, the high-pressure stream is expanded through a Joule-Thompson valve to the storage pressure (up to point 5_G) and temperature of 20K. At this point, the hydrogen is in a two-phase state and the gas phase is recycled through the heat exchanger HX2 and HX1 for re-compression. The resulting liquid-hydrogen yield of such a system will vary in the range of 7–15% depending on the initial and final pressures. The final hydrogen temperature prior to expansion is a key variable for optimisation.

The advantage of using a cooling bath is to allow a greater amount of energy to be removed from the input hydrogen stream at higher temperatures. This increases the overall efficiency of the cycle. An additional feature in this system is the incorporation of an ortho-para catalyst in the inner passages of the hydrogen stream in HX1, LN₂ and HX2. This catalyst allows for the heat of conversion to be removed continuously and more efficiently. For input hydrogen stream pressures varying in the region of 50 to 100 bar, the return low-pressure hydrogen stream mass flow rates will vary as 0.10 g/s to 0.17 g/s.

Schematic of the proposed pre-cooled Linde-Hampson system for hydrogen liquefaction. Ortho-para hydrogen conversion takes place in a HX1 and HX2 zones

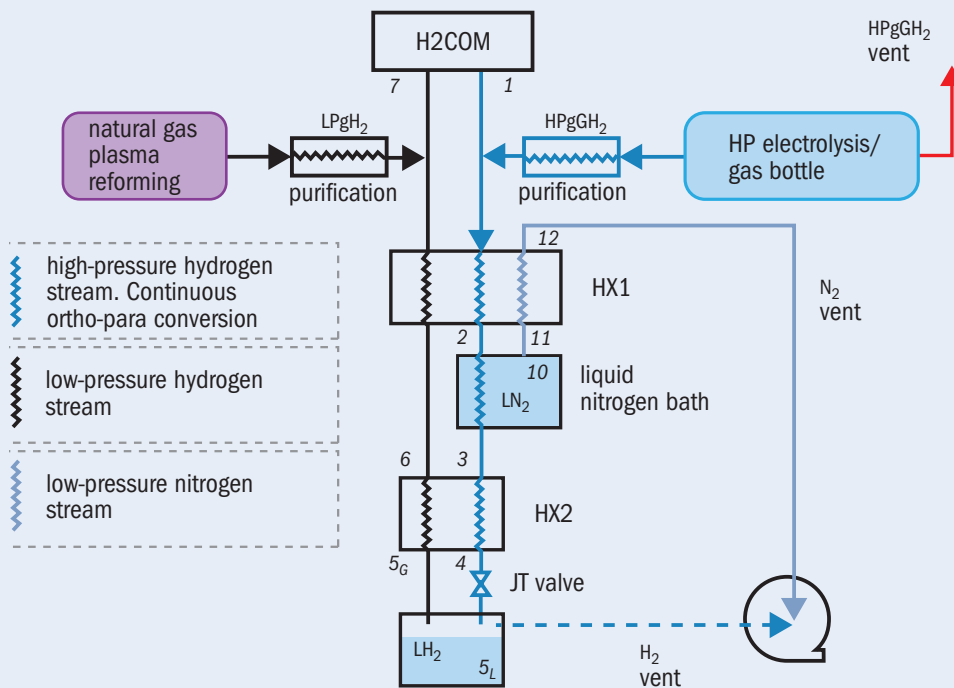

6: Cryogenic liquid hydrogen

The high-energy penalty associated with small-scale hydrogen liquefaction can be reduced through research and innovation. Such efforts are underway at the University of Cambridge centred on the magneto-caloric effect benefits of low-

temperature hydrogen vapour re-condensation after a J-T valve. This approach has demonstrated very significant energy savings at production rates of two litres of liquid hydrogen per hour.

Hydrogen liquefaction and the Joule-Thomson effect

The solid line joining maxima of the iso-enthalpic lines is called the inversion curve. The inversion curve encloses the area to the left representing a positive Joule-Thomson coefficient of the iso-enthalpic expansion of the gas leading to temperature reduction of the hydrogen gas up to liquefaction (this is the Joule-Thomson, or J-T, effect). The value of the maximum inversion temperature above which hydrogen gas cannot be liquefied using the J-T effect is 205 K. Therefore, when producing liquid hydrogen it is essential to pre-cool the compressed hydrogen gas below 205 K. Such pre-cooling is conventionally provided by liquid nitrogen at 77.4 K, but in some future applications it might be preferable and advantageous to use liquefied natural gas at 112 K.

The family of the iso-enthalpic lines on the temperature vs pressure diagram for hydrogen

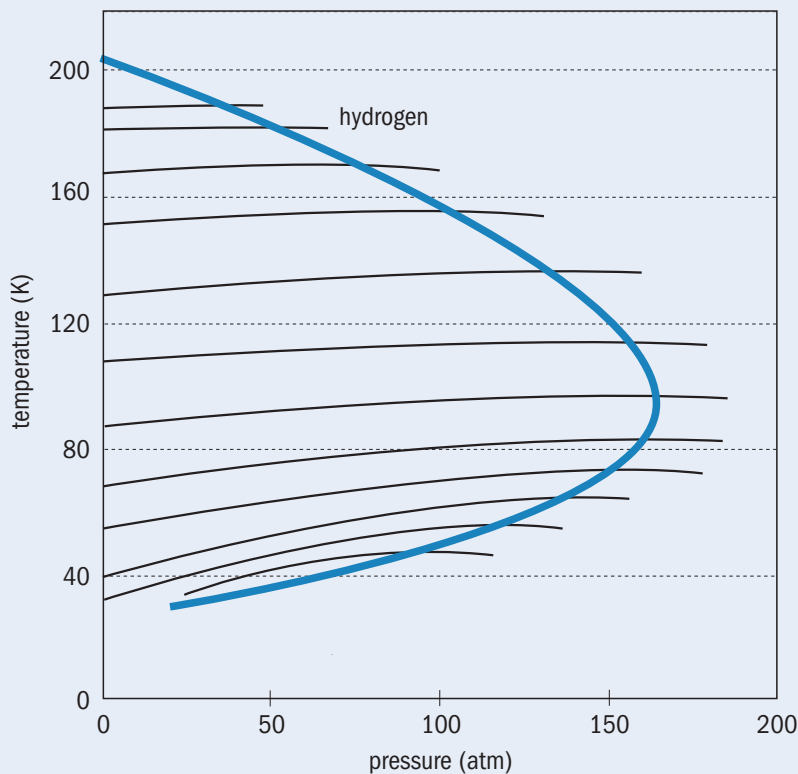

Liquid-hydrogen storage

One of the most efficient methods for hydrogen storage is to maintain it in the liquid state. The main benefit is the vastly smaller storage volumes required compared to all gaseous alternatives. However, as discussed earlier, the principle difficulty is achieving the extremely low boiling point of hydrogen (20 K, equal to $-253\text{ }^{\circ}\text{C}$). The low temperatures require the hydrogen to be kept in super-insulating containers known as dewars.

The cryo-technology of liquid-hydrogen storage has been much improved in recent decades primarily at the initiative of the aerospace industry. However, liquid hydrogen is rarely associated with private automobiles partly owing to its high cost. One concern has been if a cryogenic liquid-hydrogen tank were to run dry. In that case the tank would start to warm and require specialist intervention (presumably at a main car dealership or even more centrally to restore the system). One would not imagine a member of the public refilling a warmed up tank on the forecourt. That said, if the cryogenic hydrogen were to warm to room temperature, the driver would still be able to drive some distance (eg to the main dealership). This is because the cryogenic tank would serve as a 350 atm hydrogen high-pressure gas tank [24].

One issue affecting vehicle hydrogen use is the combined weight of the stored fuel and its container. This has been a major difficulty faced by those developing gaseous-hydrogen storage systems. For liquid-hydrogen systems, the percentage of total weight relating to useful fuel has been reported to be as much as 20% or more. Generally, liquid-hydrogen systems do well in such terms. Importantly, this figure surpasses the expected target (9 wt%) established by the US Department of Energy. That policy was established on the basis of technological neutrality and was not designed to favour one technology over another. Despite the weight and energy density benefits of

liquid hydrogen, the challenges of low temperatures and the requirement for heat insulator systems tend currently to make the cryogenic liquid option inappropriate for most mobile applications. However, it is important to realise that liquid-hydrogen-cryogenic containers for cars is an already existing technology. As such, the bigger technological challenge currently is the transfer of liquid hydrogen to the car. This is a subject of a patent by the Linde Group. Such issues, together with the lack of availability of liquid-hydrogen fuelling stations, are holding back the development of liquid-hydrogen-fuelled private cars.

Noting synergies between cryogenic gases, it can be envisaged that if the cars using liquified natural gas (LNG) were to be more widely available, then this could be a turning point for the roll out of liquid-hydrogen-fuelled cars.

One should bear in mind that liquid hydrogen at 20 K is a very efficient coolant for medium- and high-temperature superconductors. Imagining a future car with onboard cryogenics opens up a wealth of possible follow-on innovations, such as superconducting technologies in navigation, magnetic bearings and flywheel superconducting energy storage. These innovations have the potential to accelerate the market penetration of liquid hydrogen, even more so if the car will be treated as a mobile energy-storage system.

For stationary solutions, standard stainless steel dewars designed for liquid helium are identical to those intended for liquid hydrogen in terms of construction and welding materials. Therefore, the storage of hydrogen in a liquid form in large helium dewars is a straightforward option and is a ready solution for a decentralised hydrogen economy. The only difference between the liquid-hydrogen and liquid-helium storage dewars is that for safety reasons, the hydrogen dewar cannot have wheels when it is filled with hydrogen.

6: Cryogenic liquid hydrogen

The importance of ortho-para conversion

Molecular hydrogen occurs in two isomeric forms, one with its two proton spins aligned parallel (orthohydrogen), the other with its two proton spins aligned antiparallel (parahydrogen). At 300 K, the equilibrium concentration is 75% ortho, while at the hydrogen boiling point (20.3 K), the equilibrium concentration is only 0.21% ortho.

There is a large energy requirement associated with the ortho to para conversion (525 J/g) of the 75% orthohydrogen. That energy must be supplied if hydrogen is to be liquefied in equilibrium. The ortho-para energy requirements exceed the latent heat of liquid hydrogen vaporisation (447 J/g). As such, the ortho-para conversion process could in principle cause a total evaporation of liquefied hydrogen.

If hydrogen is liquefied from room temperature preserving the 25:75% ratio then the concentration of parahydrogen increases in time as the system slowly equilibrates according to the following equation:

$$x_{p-H_2} = (0.25 + 0.00855t) / (1 + 0.00855t)$$

Where x_{p-H_2} is a fraction of parahydrogen converted after liquefaction from the room temperature state $x_{p-H_2 RT} = 0.25$; t is time in hours. For example: 10 hours after liquefaction, parahydrogen conversion can be $x_{p-H_2} = 0.31$ (generating ~50 J/g); while 100 hours after liquefaction parahydrogen conversion can be $x_{p-H_2} = 0.59$ (generating ~30 J/g), and 1000 hours after liquefaction conversion $x_{p-H_2} = 0.92$ (generating ~400 J/g). It is evident that if the liquid hydrogen is to be used shortly after liquefaction the ortho-para conversion does not play an important role in evaporation of the liquid hydrogen, but for the long-term storage of liquid hydrogen there is a need for an efficient and cost-effective means of conversion from orthohydrogen to parahydrogen during the liquefaction process. An incomplete conversion during liquefaction results in severe losses due to boil-off during storage and transport.

Most liquid-hydrogen manufacturers use a two-stage catalytic converter, first at 77 K and then at 20.3 K in the liquefaction process. The conversion at 77 K can produce 50% para-H₂. The remaining conversion at 20.3 K consumes a significant fraction (~50%) of the liquid hydrogen. To accelerate the ortho-para conversion during liquefaction, magnetic catalysts are used such as iron(III) oxide, rare earth metals nickel compounds and chromium(III) oxide and activated carbon. The conversion theory assumes that the accelerated change from orthohydrogen to parahydrogen occurs in the presence of the paramagnetic magnetic catalysts because the inhomogeneous magnetic field in the vicinity of a paramagnetic ion, or molecule, acts as a perturbation. During a collision between a hydrogen molecule and the paramagnetic ion, or molecule, the perturbation allows an otherwise forbidden ortho-para transition to occur.

Ortho-para hydrogen conversion can be done to high efficiency using Cr₂O₃ powder as the active element contained in a continuous heat exchanger. This method allows the heat of conversion to be removed by the hydrogen gas flow. The electronic states of Cr₂O₃ are rather complicated and have been calculated to possess many magnetic ordering states: three anti-ferromagnetic phases with different magnetic orderings, a ferromagnetic phase, and a paramagnetic phase.

The proportion of parahydrogen in equilibrium with orthohydrogen at different temperatures

Temperature (K)	20.39	30	40	70	120	200	250	300
Parahydrogen (%)	99.8	97.02	88.73	55.88	32.96	25.97	25.26	25.07

The heat of conversion of 75% orthohydrogen, 25% parahydrogen mixture at different temperatures

Temperature (K)	15	20.39	30	50	60	70	75	100	125	150	175	200	250
Q (J/g)	527	525	506	364	285	216	185	88.3	37.5	15.1	5.7	2.06	0.23

Hydrogen cryomagnetics

Two of the authors of this report came to consider hydrogen futures as a consequence of having spent much effort examining the future of helium. Much of the global use of helium relates to its use as a cryogen cooling superconducting wires, for example in high-field magnets. It became clear that liquid hydrogen at 20 K might have something to contribute to the future of superconductivity and the notion of “hydrogen cryomagnetics” emerged.

While superconductivity remains a phenomenon, with which the public has little daily connection, it has in recent decades emerged as the basis of important high-technology industries. Perhaps most prominent has been the growth of magnetic resonance imaging (MRI) as a medical diagnostic technique. Almost all commercial applications of superconductivity rely on the properties of materials at the very low temperatures associated with liquid helium ($T_{\text{NBP}} = 4.2 \text{ K}$, where NBP = Normal Boiling Point). Increasingly, MRI systems are using mechanical cryo-coolers to achieve these temperatures, although the MRI industry continues to require very large amounts of liquid helium in the MRI scanner manufacturing process at the factory. Equipment testing and cooling for delivery are the main processes demanding liquid helium.

The use of liquid hydrogen at its atmospheric pressure equilibrium temperature of 20 K ($-253 \text{ }^\circ\text{C}$) might be combined with the use of modern higher-temperature superconductors (HTS) to achieve magnetic services and solutions free from the risks of escalating helium prices. The challenges facing helium going forward have been summarised by Nuttall et al [25]. As such, hydrogen cryomagnetics enters a competition with mechanical recirculating cryo-coolers (with associated energy costs) or with substitution away from superconductivity altogether.

One good candidate superconductor for hydrogen cryomagnetic systems is magnesium diboride (MgB_2).

MgB_2 wires

There is a need in the market for low-cost, high-efficiency superconducting magnets for medium- and high-field applications. Superconducting magnets made using HTS wires such as $\text{YBa}_2\text{Cu}_3\text{O}_7$ or $(\text{BiPb})_2\text{Sr}_2\text{Ca}_2\text{Cu}_3\text{O}_x$

able to operate at liquid nitrogen temperatures (-77 K) are expensive and not yet very effective. They are also not yet economically viable for mass production. Superconducting magnets manufactured using low-temperature superconductor (LTS) wires, such as niobium-titanium (NbTi) and Nb_3Sn are cheap. However, they come with the limitation of very low operating temperature (2.5–4.2 K), which requires at least a liquid helium bath, or the use of inefficient two-stage cryo-coolers.

Helium is a limited natural resource produced as a by-product of the natural gas industry, and especially the growing liquefied natural gas industry. The helium industry has a complex and unusual history combining government interventions and market failures. The history and options for the future have been summarised by Nuttall et al [25]. The future for helium is uncertain but it is clear that it has experienced volatile price fluctuations in recent years on the back of a steep upward trend. With such concerns in mind, MgB_2 wire, originally developed at Cambridge University [26], offers a unique opportunity for substitution away from helium in superconductivity technology as it can be cooled directly, or indirectly, by liquid hydrogen due to its 39 K critical superconductivity temperature.

The magnetic and electrical properties of MgB_2 are highly favourable for a wide range of applications. In addition, its operational temperature (14–20 K) can be achieved using relatively cheap and abundant liquid hydrogen for cooling.

The cost of MgB_2 wires is significantly lower than that of other superconducting materials (both HTS and LTS). Magnesium and boron are both readily and cheaply available. They are abundant materials in nature. Consequently, the combination of low-cost initial materials and lower-cost cooling favours the mass production of MgB_2 superconducting wires for a broad range of medium magnetic field and high-current superconducting cable applications. Potential large-scale applications of MgB_2 cryomagnetics include generators, motors, storage units, induction coils, DC superconducting cables and even coils for future fusion reactors [27] and [28].

Magnet MgB_2 systems should ideally operate in a persistent current mode so that there is no need

6: Cryogenic liquid hydrogen

Medium- and high-temperature superconducting materials

In the late 1980s, solid-state physics was rocked by the news that superconductivity had been discovered in materials at temperatures far higher than anything previously observed – High Temperature Superconductors (HTS) were born. It was initially expected that a range of utterly disruptive and transformative engineering applications would follow, but thus far reality has failed to meet initial expectations. One problem was that at liquid-nitrogen temperature (77 K), the superconducting properties of the new HTS materials were weak. To achieve dramatic performances lower temperatures were required and conventionally that meant liquid helium at 4.2 K. Another problem was the high cost of the elements from which the HTS materials tended to be made.

The graph below shows that at 20 K, the MgB_2 and $(Bi,Pb)_2Sr_2Ca_2Cu_2O_x$ irreversibility lines reach sufficiently high values to be applicable for useful magnet manufacture. Obviously, $YBa_2Cu_3O_7$ would also benefit from lower temperature high performance. This could be of great benefit for superconducting magnet applications requiring persistent mode at around 20 K. Such cooling can be provided at low cost by liquid hydrogen. In addition, there is interesting research and development underway into compact and low-power Stirling cryo-coolers operating at liquid hydrogen temperatures [G1].

If 20 K cryogenic temperatures are produced just to enable superconducting devices made from MTS and HTS materials using conventional liquid helium cooling, and with no connection to a liquid-hydrogen energy economy, then running costs can be expected to be prohibitively high for most applications. It is the transition to liquid-hydrogen cooling and hence to hydrogen cryomagnetics that could represent an attractive cost-efficient alternative to expensive liquid helium.

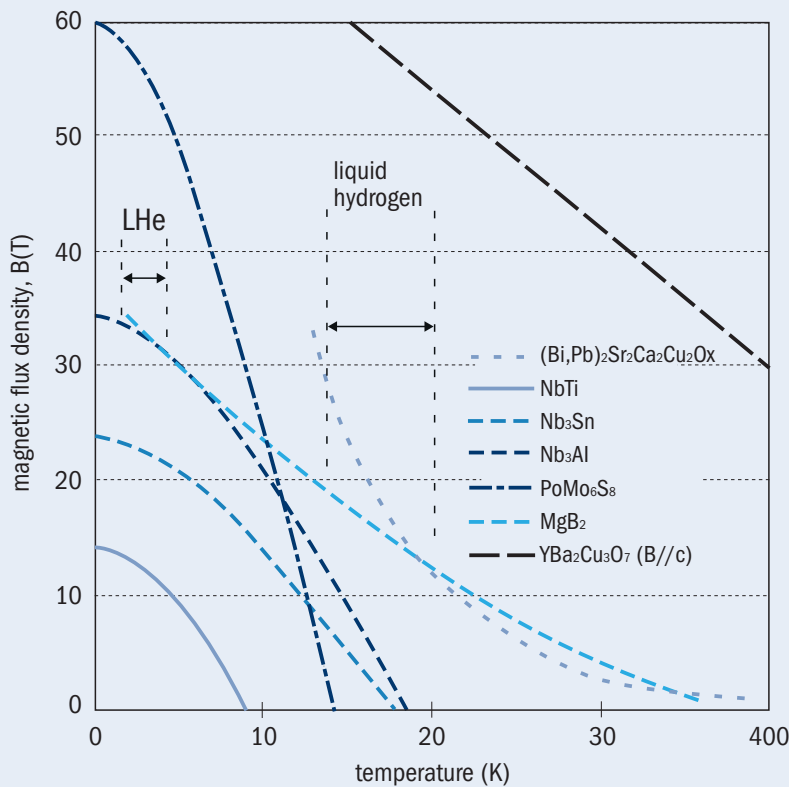

Magnetic flux density irreversibility, B_{irr} , versus temperature, T , for: low-critical-temperature superconductors, medium-critical-temperature superconductor MgB_2 ($T_c = 39$ K) and high-critical-temperature superconductor $YBa_2Cu_3O_7$ (magnetic flux density, B , is parallel to crystallographic c -direction of the superconducting $YBa_2Cu_3O_7$ layer). Source: The Future of Helium as a Natural Resource, ed. by W J Nuttall, R H Clarke and B A Glowacki, Chapter 16 (2012)

for current leads and the current loss affecting the performance of the system can be eliminated. Switches and joints can be designed in a manner that the superconductivity state is maintained in the circuit to sustain the persistent mode.

Obviously, other superconducting materials such as rare-earth based “RE-123” compounds, bismuth-based materials, thallium and mercury-based materials, and iron-based compounds could all also benefit from low-temperature cooling provided by liquid hydrogen.

Liquid hydrogen and electricity futures

The large-scale use of superconductivity in the transmission and distribution of electricity can have substantial impact on energy systems. In particular, the future electricity system is expected to include both local smart distribution grids and long-distance low-loss supergrids. The use of direct current (DC) systems offers advantages for the large-scale integration of renewable electricity sources, such as wind, photovoltaic and ocean-wave power. At the large scale, supergrids can be developed on the basis of high-voltage-direct-current while at the local scale new smart distribution systems may include semi-autonomous microgrids. Grid innovations at all scales have the potential to benefit from low-loss superconducting DC technology.

A great deal of research into alternating current (AC) and DC cables based on HTS tapes exists

[29]–[37]. However, relatively little attention has been given to cables using MgB_2 . As described, magnesium diboride is a particularly attractive material for future superconducting applications cooled with liquid hydrogen. In fact, two possible cooling options exist for MgB_2 systems at 14–20 K: liquid hydrogen and gaseous helium. Hybrid transfer lines, designed to transport liquid hydrogen as well as electricity via MgB_2 , have been proposed [38], [39] and recently demonstrated experimentally [40], [41]. Such transfer lines could form the basis of energy feeds to cities of the future. Cabling with MgB_2 strands does not degrade the critical current [42], [43]: indeed, improvement in critical currents after cabling has been reported [44].

The integration of hybrid transfer lines with micro-grid applications has been studied [45]. To avoid safety dangers inherent in using liquid hydrogen, gaseous helium can be used as an alternative, perhaps on the basis of heat exchange with cryogenic liquid hydrogen. Gaseous helium cooling has already been demonstrated as a cooling medium for HTS tapes [46], [47] at approximately 30–50 K. Recently, Tsinghua University, University of Cambridge and MIT have been collaborating to design, construct, and test an MgB_2 DC cable for micro-grid applications. The system was installed in the State Key Laboratory of Power Systems at Tsinghua University in Beijing, China in 2014 [48].

Hydrogen safety: perceptions and realities

The limits of detonation of hydrogen in air are 18.3–59% by volume. Hydrogen, in both the liquid and gaseous states, is particularly subject to leakage because of its low viscosity and low molecular weight. In addition, hydrogen can be ignited at relatively low concentrations. These technical realities underpin a major public anxiety and significant expert concern.

However, notwithstanding the legitimacy of the safety concerns, it must be noted that hydrogen is in key respects less hazardous than gasoline, which can splash and flow quite unlike hydrogen and which combusts in an altogether more threatening way. A hydrogen fire burns directly upwards. That said, hydrogen fires are difficult to see in daylight compared to more typical incidents. These issues are of particular concern to first responders, such as firefighters. For a broader overview of hydrogen safety issues, see the work of Ricci et al [49].

Liquid-hydrogen safety

Liquid hydrogen brings with it additional safety concerns beyond those applying to hydrogen gas. These include concerns for cryogenic safety, but also concerns arising as a consequence of higher stored energy densities.

When considering liquid-hydrogen storage, one must not only consider the dewars and cryogenic equipment, but also the location of the dewars and issues of spatial confinement. Aspects to

be considered include oxygen displacement (asphyxiation) and, at lesser concentrations, explosion. In addition the presence of electrical systems inside the confined space, dictate certain safety requirements to minimise the risk of ignition. However, as we shall see, leak avoidance is the key to cost-effective risk minimisation.

The central approach to safety must be based on a plan to avoid all risk of an explosion rather than a plan to cope with an explosion. As such, the system must be designed so that no leak or release of hydrogen into an enclosure occurs in the event of either a failure of any subsystem or of any cryogenic vessel.

The preferred approach to safety design is to prevent any hydrogen release and hence to allow for the possible use of ordinary laboratory or engineering equipment as far as possible. If one adopts such an approach there is, for example, no need for special explosion-proof electronics. Robust design of the storage vessels and gas distribution piping, the existence of appropriate relief paths to a vent box, and gaseous nitrogen jacketing can together ensure that the release of any hydrogen into a confined working space is extremely unlikely. In the unlikely event that a hazardous leak were to occur, hydrogen alarm systems can act quickly and provide a useful supplementary safety measure.

Hydrogen and gasoline car fires 3 and 60 seconds after ignition (hydrogen flow rate: 5 kg/min).

Source: Ulster University



Potential disruptive innovations

Looking ahead, one can imagine a range of potentially highly disruptive innovations associated with the increased commercialisation of hydrogen. Some are held back by market realities (and market failures – such as a proper price for greenhouse gas emissions) while others are held back by technological difficulties. Some innovations have been anticipated by those pursuing publicly funded research towards a fuel-cell-based low-carbon transport system, while others may emerge from today's chemical-process industries. In this report, emphasis is given to cryogenic technologies noting the significant role for physics and physicists in that domain.

Synergies between cryogenic liquids for energy

There is a growing role for cryogenics in the future energy system. By far the most important aspect concerns the rapid growth of 112 K liquefied natural gas (LNG) as a competitor to conventional pipeline gas. Many tens of billions of dollars have been invested in this technology, especially in the last 15 years. One can observe that LNG has particular potential as a valuable cryogenic medium which could, for example, be used to pre-cool hydrogen below the inversion temperature $\sim 200\text{K}$ ($\sim -73\text{ }^\circ\text{C}$). This is the temperature below that hydrogen gas can be successfully and effectively liquefied. Thinking even further ahead one can observe that the HTS material mercury barium calcium copper oxide superconductor has its critical temperature fully 23° above LNG boiling temperature under normal pressure. Surely in the future, good use will be made of this.

Less high-tech, but no less importantly, much effort is going into using cryogenic liquid air for energy storage. This is despite the fact that air has no calorific value. The regasification of previously liquefied air (using ambient or low-grade heat) can release energy that can usefully turn an electricity-generating turbine. If that is an example of clever mechanical engineering, one must of course not forget chemical engineering that could help produce a range of liquid low-carbon fuels with attributes even better than liquid hydrogen. In this respect liquid ammonia comes to mind. Shanwen Tao of the DoSH₂ consortium has considered such possibilities.

In the UK, the Science and Technologies Facilities Council announced in 2014 a breakthrough innovation that improves the prospects of commercialising ammonia as a vehicle fuel [50]. Ammonia has the advantage that it is a relatively easily stored liquid at room temperature. Rather than combust ammonia directly, which would entail environmental and possible safety risks, there are advantages in catalytically separating the ammonia into hydrogen and molecular nitrogen just prior to hydrogen usage. Historically, this has required very expensive precious metal catalysts, but the STFC researchers report that they have discovered a much cheaper alternative chemical approach avoiding the need for catalysts altogether.

Microwave plasma generation of hydrogen

One long-standing problem associated with the production of hydrogen from methane has been the release of carbon dioxide (CO₂) into the atmosphere. Fitting CO₂ scrubbing technology and deploying carbon capture and storage to a natural-gas steam-reforming plant would be a major and costly undertaking. Physics has however revealed an alternative approach to natural-gas processing that essentially avoids the production of gaseous CO₂. The new approach is non-equilibrium, atmospheric pressure microwave plasma reforming of natural gas to hydrogen and solid carbon. It has attracted strong interest because of its advantages over thermal splitting of natural gas and other types of plasma processing. Due to the absence of thermal equilibrium between the reacting species in non-thermal plasmas, gas phase reactions occur at relatively low bulk temperatures and with high efficiency. This would not be possible in thermally generated conditions.

Microwaves, as the source of plasma discharges, generate large volumes of plasma in a compact system without the necessity of using noble gases or sophisticated cooling systems during processing. Glowacki and colleagues have developed an industrial 3 kW microwave plasma reactor, which allows for stable and continuous hydrocarbon processing with high conversion rates and good energy efficiency. The system is applicable to natural gas without purification. In

8: Potential disruptive innovations

non-catalytic conditions, a high conversion of natural gas, exceeding 90%, can be achieved, with hydrogen selectivity of up to 85% and the production of solid carbon (not gaseous CO₂) in the form of valuable carbon nanoforms. The DoSH₂ consortium has also considered similar issues [51].

LH2 and vacuum technologies

We see the possibility of a role for cryogenic liquid hydrogen in improving cryogenic turbo-pumping, sorption pumping and cryo-distillation [22]. The safety issues associated with the use of cryogenic LH2 might restrict applicability to certain industrial applications, but the cost advantages over traditional liquid-helium approaches could be decisive in the years ahead.

Conclusions

In preparing this report, the authors have deliberately chosen to emphasise the role that physics and physicists are likely to play in the future of hydrogen-based technological innovation. In so doing they have sought to add to, rather than duplicate, the existing extensive hydrogen futures literature. Much of that pre-existing literature emerged during an international wave of enthusiasm for hydrogen technology in the middle of the last decade, eg the work of McDowall and Eames [7], [8], [11]. More recently, Nick Hacking of the UK DoSH₂ consortium has prepared a literature review [52]. He observes that innovation in the area of hydrogen is progressing rapidly and reflects several important aspects of the theory of innovation systems. In particular, learning among actor networks is key, especially as collective action will be required to bring forward essential hydrogen infrastructure development. While such observations are no doubt correct, the authors of this report share the opinion of Steven Stoft and

Cesar Dopazo of the EU Sixth Framework project CESSA when they observed: "... the penetration of most hydrogen technologies is a long-term issue. A priori favouring of specific technologies for massive deployment can be an incorrect strategy and even detrimental to the long-term hydrogen future. Proper economic public incentives should be established for different alternative competing technologies. Then entrepreneurs should look for the niche and related markets that could spawn earlier and wider applications of hydrogen." [53].

Noting the uncertainty that lies ahead, it is perhaps appropriate to close with some salutary words commonly attributed to a famous physicist, Niels Bohr, and applicable to the way ahead for hydrogen:

"Prediction is very difficult, especially about the future."

Acknowledgements

The authors are most grateful to numerous colleagues who have helped develop our understanding of the issues facing hydrogen including: Toks Bakenne, Richard Clarke, David Hart, Rick Jeffries, Nick Kazantzis, Joe Minervini, Steve Steer and many others. The opinions expressed in this report are those of the authors alone and do not necessarily reflect the views of those that have offered us assistance. All responsibility for errors or omissions rests with the

authors alone. We are also most grateful to Tajinder Panesor for commissioning the report and for offering good advice, and those from the Institute of Physics who reviewed a draft of this report.

Notes

One of the authors, B A Glowacki, declares an interest in Epoch Wires Ltd, a manufacturer of MgB₂ superconducting wires.

References

- [1] National Statistics (and DECC), UK Energy in Brief 2015, available at www.gov.uk/government/statistics/uk-energy-in-brief-2015 accessed 18 March 2016
- [2] M Contestabile, G J Offer, R Slade, F Jaeger and M Thoennes, Battery Electric Vehicles, Hydrogen Fuel Cells and Biofuels. Which will be the winner? In Energy and Environmental Science, vol. 4 (2011)
- [3] W McDowall and M Eames, International Journal of Hydrogen Energy, vol. 32 (December 2007)
- [4] M Eames and W McDowall, Technology Analysis & Strategic Management, vol. 22, issue 6 (2010)
- [5] MarketsandMarkets, press release relating to report Global Hydrogen Generation Market by Merchant & Captive Type, Distributed & Centralized Generation, Application and Technology – Trends & Forecasts (2011–2016), available at www.marketsandmarkets.com/PressReleases/hydrogen.asp accessed 12 January 2014
- [6] W McDowall and M Eames, Energy Policy, vol. 34 (2006)
- [7] J Ogden, Fuel Cells And More, Scientific American, vol. 295 (2006)
- [8] CIFAL website www.cifalscotland.org/index.php/headlines/137-scotlands-hydrogen-plans-welcomed-as-an-exciting-first-for-the-uk accessed 26 May 2014
- [9] G Tao, S Bandopadhyay, H Anderson, R Brow and A Virkar, Development of a Novel Efficient Solid-Oxide Hybrid for Co-Generation of Hydrogen and Electricity Using Nearby Resources for Local Application, DOE Hydrogen Program FY 2007 Annual Progress Report, available at www.hydrogen.energy.gov/pdfs/progress07/ii_c_5_tao.pdf accessed 18 March 2014
- [10] K Bullis, Electric Vehicles Out in the Cold, Technology Review, 13 December 2013, available at www.technologyreview.com/news/522496/electric-vehicles-out-in-the-cold/ accessed 2 March 2014
- [11] R Koc, PhD Thesis, Worcester Polytechnic Institute USA (2012)
- [12] Grunewald et al, Energy Policy, vol. 39, issue 9 (September 2011)
- [13] DoSH₂ Project summary website www.uk-cpi.com/wp-content/uploads/2012/12/00242-EEN-A4-SUPERGEN-Brochurev6-FINAL-260112.pdf, accessed 27 May 2014
- [14] Gasworld Magazine, South Africa Hydrogen Challenge Overcome, issue 99 (August 2013)
- [15] BioCat Project website <http://biocat-project.com/news/present-commodo-cursus/>, accessed 15 February 2014
- [16] P Ekins, S Hawkins and N Hughes, Hydrogen Technologies and Costs, in Hydrogen Energy – Economic and Social Challenges, ed. by Paul Ekins (2010)
- [17] B Russ, Sulfur Iodine Process Summary for the Hydrogen Technology Down-Selection, Idaho National Laboratory (May 2009)
- [18] Air Products, Gasworld magazine (August 2013)
- [19] N Balta-Ozkan and N Strachan, Hydrogen System Modelling, in Hydrogen Energy, ed. by P Ekins (2010)
- [20] The Future of Helium as a Natural Resource, ed. by W J Nuttall, R Clarke, B Glowacki (2012)

11: References

- [21] B A Glowacki, W J Nuttall, E Hanley, L Kennedy, D O'Flynn, Hydrogen Cryomagnetism for Decentralised Energy Management and Superconductivity, *Journal of Superconductivity and Novel Magnetism*, vol. 28, issue 2 (February 2015)
- [22] R H Clarke, B A Glowacki, Indirect hydrogen versus helium or nitrogen cooling for fusion cryogenic and magnet systems, *Proceedings of ICEC 23 – ICMC 2010*
- [23] K T McDonald, M Iarocci, H G Kirk, G T Mulholland, P H Titus and R J Weggel, Use of He Gas Cooled by Liquid Hydrogen with a 15-T Pulsed Copper Solenoid Magnet, Technical/Economic Report August 15 (2009); also *Proceedings of ICEC 23 – ICMC 2010*
- [24] US Department of Energy Hydrogen Program, Technical Assessment: Cryo-Compressed Hydrogen Storage for Vehicular Applications (October 2006)
- [25] *The Future of Helium as a Natural Resource*, ed. by W J Nuttall, R Clarke, B Glowacki (2012)
- [26] B A Glowacki, M Majoros, M Vickers, J E Evetts, Y Shi and I McDougall, Superconductivity of powder in-tube MgB₂ wires, *Superconductor Science and Technology*, vol. 14, issue 4 (April 2001)
- [27] W J Nuttall, R Clarke and B A Glowacki, 'Fusion Island' East of England Energy Group Annual Innovation Awards 2006
- [28] B A Glowacki and W J Nuttall, Assessment of liquid hydrogen cooled MgB₂ conductors for magnetically confined fusion in *Journal of Physics: Conference Series*, 97 012333 (March 2008)
- [29] C S Weber, R Lee, S Ringo, T Masuda, H Yumura and J Moscovic, Testing and demonstration results of the 350 m long HTS cable system installed in Albany, NY, in *IEEE Transactions on Applied Superconductivity*, vol. 17, no. 2 (June 2007)
- [30] Y Xin, B Hou, Y Bi, H Xi, Y Zhang, A Ren, X Yang, Z Han, S Wu, and H Ding, Introduction of China's first live grid installed HTS power cable system, in *IEEE Transactions on Applied Superconductivity*, vol. 15, no. 2 (June 2005)
- [31] J A Demko, I Sauers, D R James, M J Gouge, D Lindsay, M Roden, J Tolbert, D Willen, C Traeholt, and C T Nielsen, Triaxial HTS cable for the AEP bixby project, in *IEEE Transactions on Applied Superconductivity*, vol. 17, no. 2 (June 2007)
- [32] N Steve, M Nassi, M Bechis, P Ladie, N Kelley and C Wakefield, High temperature superconducting cable field demonstration at Detroit Edison, in *Physica C: Superconductivity and its Applications*, vol. 354, no. 1–4 (May 2001)
- [33] High Temperature Superconductivity Demonstration Projects, 2009, available at <http://energy.gov/oe/downloads/high-temperature-superconductivity-cable-demonstration-projects>, accessed 22 January 2016
- [34] S H Sohn, J H Lim, B M Yang, S K Lee, H-M Jang, Y H Kim, H S Yang, D L Kim, H R Kim and S W Yim, Design and development of 500 m-long HTS cable system in the KEPCO power grid, Korea, *Physica C: Superconductivity and its Applications*, vol. 470, no. 20 (November 2010)
- [35] J F Maguire, F Schmidt, S Bratt, T E Welsh, J Yuan, A Allais, and F Hamber, Development and demonstration of a HTS power cable to operate in the long island power authority transmission grid, *IEEE Transactions on Applied Superconductivity*, vol. 17, no. 2 (June 2007)

- [36] J Cho, J H Bae, H J Kim, K D Kim, K C Seong, H-M Jang and D W Kim, “Development and testing of 30m HTS power transmission cable,” *IEEE Transactions on Applied Superconductivity*, vol. 15, no. 2 (June 2005)
- [37] S Yamaguchi, T Kawahara and M Hamabe, Experiment of 200-meter superconducting DC cable system in Chubu University, *Physica C: Superconductivity and its Applications*, vol. 471, no. 21/22 (November 2011)
- [38] S Yamada, Y Hishinuma, T Uede, K Schippl, N Yanagi, T Mito, and M Sato, “Conceptual design of 1 GW class hybrid energy transfer line of hydrogen and electricity,” *Journal of Physics Conference Series*, vol. 234, no. 3 (2010)
- [39] S Yamada, Y Hishinuma, T Uede, K Schippl and O Motojima, Study on 1 GW class hybrid energy transfer line of hydrogen and electricity, *Journal of Physics Conference Series*, vol. 97, no. 1 (2008)
- [40] V V Kostyuk, I V Antyukhov, E V Blagov, V S Vysotsky, B I Katorgin, A A Nosov, S S Fetisov and V P Firsov, Experimental hybrid power transmission line with liquid hydrogen and MgB₂-based superconducting cable, *Technical Physics Letters*, vol. 38, no. 3 (March 2012)
- [41] V Vysotsky, S Fetisov, A Nosov, G Svalov, E Blagov, V Kostyuk, B Katorgin, V Firsov, I Antyukhov and A Rakhmanov, Hybrid energy transfer line with liquid hydrogen superconducting MgB₂ cable—First experimental proof of concept, *IEEE Transactions on Applied Superconductivity*, vol. 23, no. 3 (June 2013)
- [42] R Musenich, M Greco, M Razeti and G Tavilla, Electrical characterization of a multi-strand MgB₂ cable, *Superconductor Science and Technology*, vol. 20, no. 3 (March 2007)
- [43] I Hušek, P Kováč, T Melišek and L Kopera, Transport current densities of MgB₂ wire, cable and continually transposed conductor, *Cryogenics*, vol. 49, no. 7 (July 2009)
- [44] T Holúbek, S I Schlachter and W Goldacker, Fabrication and transport properties of superconducting MgB₂ cables, *Superconductor Science and Technology*, vol. 22, no. 5 (May 2009)
- [45] T Nakayama, T Yagai, M Tsuda and T Hamajima, Micro power grid system with SMES and superconducting cable modules cooled by liquid hydrogen, *IEEE Transactions on Applied Superconductivity*, vol. 19, no. 3 (June 2009)
- [46] B K Fitzpatrick, J T Kephartl and E M Golda, Characterization of gaseous helium flow cryogen in a flexible cryostat for naval applications of high temperature superconductors, *IEEE Transactions on Applied Superconductivity*, vol. 17, no. 2 (June 2007)
- [47] S Pamidi, C Kim, J Kim and D Crook, Cryogenic helium gas circulation system for advanced characterization of superconducting cables and other devices, *Cryogenics*, vol. 52, no. 4–6 (April–June 2012)
- [48] M J Cheadle, M Woźniak, L Bromberg, B A Glowacki, X Jiang, R Zeng, J V Minervini and J G Brisson, DC Superconducting Cable Using MgB₂ Wires, *IEEE Transactions on Applied Superconductivity*, vol. 23 (June 2013)
- [49] M Ricci, P Bellaby and R Flynn, Hydrogen Risks: A Critical Analysis of Expert Knowledge and Expectations, *Hydrogen Energy – Economic and Social Challenges*, ed. by P Ekins (2010)

11: References

[50] Hydrogen breakthrough could be a game-changer for the future of car fuels www.stfc.ac.uk/news/hydrogen-breakthrough-could-be-a-game-changer-for-the-future-of-car-fuels/, accessed 15 February 2016

[51] We note the work of Christopher Whitehead at Manchester University

[52] N Hacking, Models of Innovation, their policy implications and hydrogen and fuel cells (HFCs) literature, EPSRC SuperGen XIV working Paper 4.2, Cardiff University (March 2013)

[53] S Stoft and C Dopazo, R&D Programs for Hydrogen: US and EU, Security of Energy Supply in Europe, ed. by F Leveque et al (2010)

[B1] G-H Tzenga, C-W Lina and S Opricovich, Multi-criteria analysis of alternative fuel buses for public transportation, Energy Policy, vol. 33, issue 11 (July 2005)

[B2] Eric Prades, Hydrogen Technologies are Ready to be Deployed, Gasworld Magazine, issue 99, (August 2013)

[C1] K T McDonald, M Iarocci, H G Kirk, G T Mulholland, P H Titus, and R J Weggel, Use of He Gas Cooled by Liquid Hydrogen with a 15-T Pulsed Copper Solenoid Magnet, Technical/Economic Report, E951 (2002); also Proceedings of ICEC 23 – ICMC 2010

For further information contact:

Daniel Lee

IOP Institute of Physics

76 Portland Place, London W1B 1NT

Tel +44 (0)20 7470 4826, Fax +44 (0)20 7470 4848

Email daniel.lee@iop.org

www.iop.org

Registered charity number 293851 (England & Wales)
and SC040092 (Scotland)

The report is available to download from our website and if you require an alternative format please contact us to discuss your requirements.



The Kitemark is a symbol of certification by BSI and has been awarded to the Institute of Physics for exceptional practice in environmental management systems.

Certificate number: EMS 573735