

Blockage formation experiments in a water rod bundle

Karsten Litfin, Jasmin Klupp, Andreas Class

Solid particles flowing into (or within) the core of a nuclear reactor can block one or more sub-channels of a fuel assembly. As they do not affect substantially the outlet conditions (temperature, pressure), they can go unnoticed by the global instrumentation. However, they lead to local heat transfer degradation and the corresponding increase of the cladding temperature. Under certain conditions, depending among others on the size, location and porosity of the blockage, this can result in local fuel cladding failure. Thus, a deep understanding of the formation and main characteristics of these blockages is essential for the development and safety assessment of innovative reactor concepts based on heavy liquid metal coolant, i.e. with particles, that have usually lower density than the coolant.

Former intensive test programs on particle formation in sodium and water-based systems [1], [2] cannot or can only limited be transferred to heavy liquid metal (HLM) cooled reactors, as they are based on particles with higher density than the coolant [3]. For this reason, dedicated experiments with the proper density ratio are mandatory.

For these tests, a 19-pin hexagonal fuel bundle mock-up in a transparent flow channel subjected to a water flow seeded with buoyant particles of relevant density, size, shape and wetting properties has been set up at the Karlsruhe Liquid Metal Laboratory corresponding to the dimensions of the Lead-Bismuth (LBE) cooled MYRRHA research reactor projected in Mol, Belgium.

The nature of the blockage as well as the formation is characterized by optical measurements, supplemented by flow rate, pressure

handling of the particles, both an injection (upstream of the test section) and extraction (downstream) subsystem has been implemented into the existing facility. The density ratio liquid/particle was to fulfil the applicable scaling laws between the water tests and the HLM reactor.

Experimental Setup

The KALLA water loop was originally used for water rod bundle experiments in the framework of EU-Project DEMETRA. A complete description of the experiments and the loop design can be found here [4].

The maximum flow rate of the loop is 130m³/h with a pressure head of 14.7 bar. The active loop inventory is 80l, the maximum total inventory is about 8m³. The loop is equipped with a heat exchanger to keep a constant fluid temperature and a cleaning system to remove used particles. Due to the PMMA test section the temperature is limited to 50°C. The flow rate is measured by a commercial flow-meter.

Rod bundle test section

The geometrical details of the 19-pin rod bundle for the blockage formation and growth experiment is shown in Figure 1, the comparison between the experimental setup and the conditions in the MYRRHA reactor rod bundle in Table 1. A detailed figure and a picture of the test section including the particle injection is given in Figure 2.

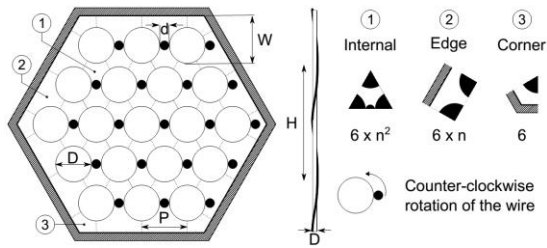

Figure 1: Water rod bundle geometry

Table 1: Geometric parameters used for the test section compared with MYRRHA reactor core geometry

Parameter	Symbol	MYRTE test at KALLA	MYRRHA	Ratio
Number of rods, -	N	19	127	0.15
Rod outer diameter	D , mm	6.55	6.55	1
Distance between rod centers (pitch)	P , mm	8.378	8.378	1
Pitch-to-diameter ratio	P/D , -	1.279	1.279	1
Flat-to-flat distance	FF , mm	39.5	97.55	0.4049
Wall distance	W , mm	8.5139	8.5166	≈ 1
Wall distance-to-diameter ratio	W/D , -	1.2998	1.3002	≈ 1
Wire diameter	d , mm	1.80	1.80	1
Wire pitch	H , mm	262	262	1
Wire pitch-to-diameter ratio	H/D , -	40	40	1
Total length	L , mm	655	1400	0.467
Total length-to-wire pitch ratio	L/H , -	2.5	5.4	0.467
Flow area (complete bundle)	$A_{b,d}$, mm ²	662.6	3638.6	0.1821
Hydraulic diameter (complete bundle)	$d_{h,d}$, mm	4.173	3.966	1.052
Flow area (internal sub-channels)	A_{sch} , mm ²	12.273	12.273	1
Hydraulic diameter (internal sub-channels)	$d_{h,sch}$, mm	3.743	3.743	1

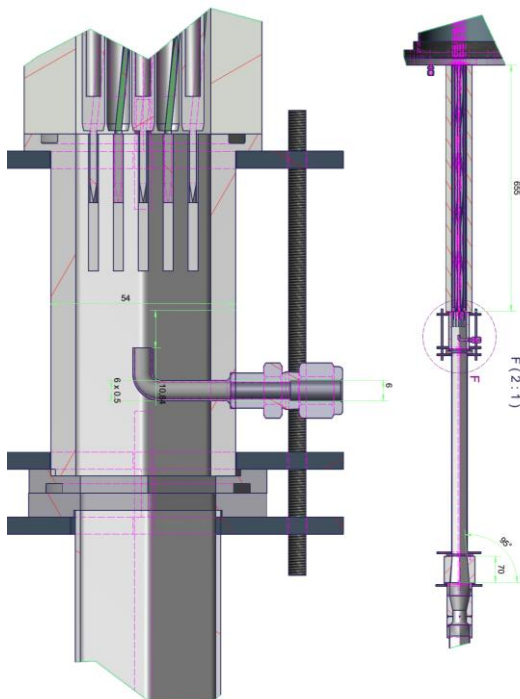

Figure 2a: Detailed drawing of the foot part of the test section with the particle insertion (left) and the optical parts of the MYRTE test section (right).



Figure 2b: Picture of the mounted test section

Instrumentation

The PMMA housing offers direct optical access to the blockages through the PMMA casing of the rod bundle. However, this access is restricted to the outer sub channels only as shown in Figure 3.



Figure 3: Picture of a blockage in the wall sub channel through the PMMA casing

The blockages of the inner sub channels are optically detected by an endoscope that is inserted in one of the PMMA tubes of the rod bundle as depicted in Figure 4. As the endoscope is equipped with its own light source, further illumination of the investigated part of the rod bundle is not necessary.

The use of this endoscopic system is a result of a comparison of different measurement techniques for the detection of the expected blockages by J. Biernath in his Master thesis [5]. It turned out that acoustic measurements are not suitable for this experiment as the complicated movement of the UDV (ultrasonic doppler velocimetry) sensor heads and the expected interference signals prohibit a reliable detection of the blockage. From the optical measurements the endoscope was the easiest and most reliable option.

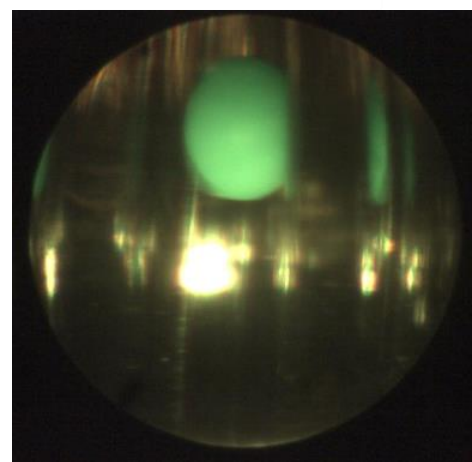
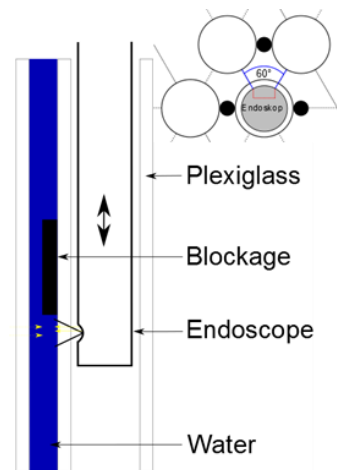

Figure 4: Scheme of an endoscope inserted into the rod-bundle mockup for blockage investigation (top) and a detected particle (bottom)

Experiments

For the blockage experiments, polypropylene particles with the density of 0.946g/cm³ were used to simulate possible blockage formation of Lead oxide in LBE as the density ratio is very similar as shown in Table 2.

Table 2: Density of blockage material for the experiment

Material	Observation	$\rho_{p,MYRRHA}$ kg m ⁻³	$\frac{\rho_{p,MYRRHA}}{\rho_{LBE}}$	$\rho_{p,MYRTE}$ g cm ⁻³
Stainless steel (DIN 1.4571)	At 270°C [20]	7756	0.7474	0.746
Lead oxide (PbO)	At 20°C [7]	9530	0.9184	0.917
Iron oxide (magnetite, Fe ₃ O ₄)	At 20°C [7]	5180	0.4992	0.498
Oxide fuel (MOX, 5% porosity)	At 20°C [3]	10565	1.0181	1.016

In total 4 different experimental series have been performed with particle sizes from 1.5mm to 4.0mm diameter:

- particles that cannot pass the pin fixer followed by smaller particles
- particles that pass the pin fixer but are likely to get stuck in the sub channel
- high amount of irregular shaped particles that get stuck at the pin fixer and cause a noticeable pressure loss
- one pre blocked sub channel and small particles that should not cause a blockage formation.

The first experiment of the series is presented in this report where in 3 steps 180 particles with 3.0mm diameter followed by 70 particles with 2.0mm diameter were inserted into the flow upstream the rod bundle test section.

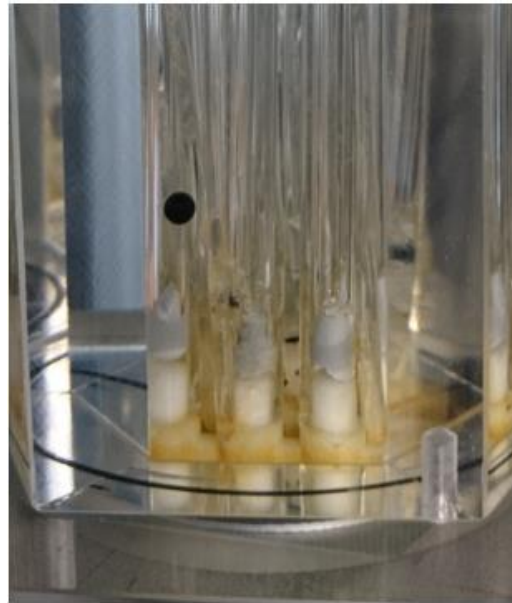

Figure 5b: One particle in a wall sub channel

Insertion of 20 particles with 3.0mm diameter

Figure 5 shows the test section after insertion of the first 20 particles (black spheres). Most particles are captured in the pin-fixer as the diameter is too big for the inner sub-channels. One particle passed the pin fixer and finally was captured in a wall sub channel. During the 20 minutes of insertion the flow rate decreased by 3% and the pressure loss of the test section increased by 1%. None of the particles was able to pass the test section.



Figure 5a: 19 particles of 3.0mm diameter in the pin fixer

Insertion of 160 more particles with 3.0mm diameter

During the second run, 160 more particles (white spheres) of 3.0mm diameter are inserted into the primary flow. Again, most particles are captured in the pin-fixer and a small fraction of 15 particles go into the wall sub channels. In total 3 wall sub channels are affected and blockages with an axial extension of up to 9 particles are visible as shown in Figure 6. Further decrease of flowrate and increase of pressure loss is depicted in Table 3.



Figure 6a: Insertion of 160 more 3.0mm particles. Pin fixer

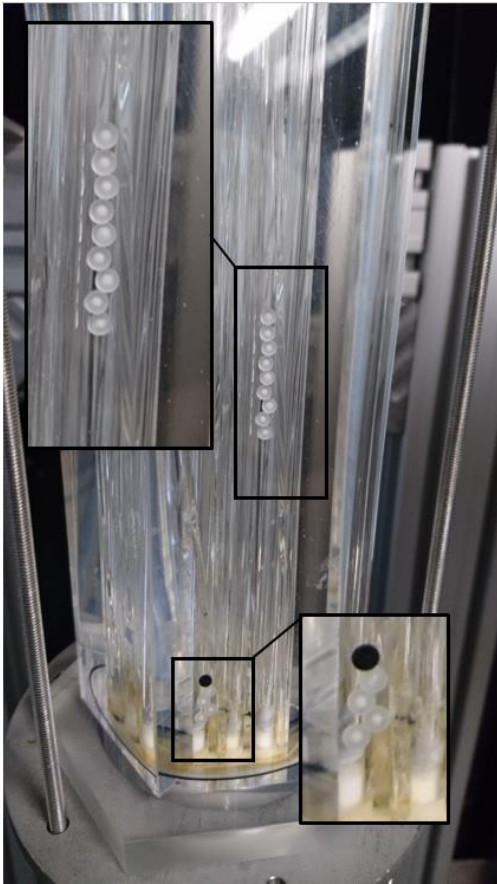

Figure 6b: Insertion of 160 more 3.0mm particles. Affected wall sub channels

set up of the experiment as well as the complete 1st run was part of a Bachelor Thesis and is described more detailed elsewhere [6]. The other experimental runs are also described in detail elsewhere [7].

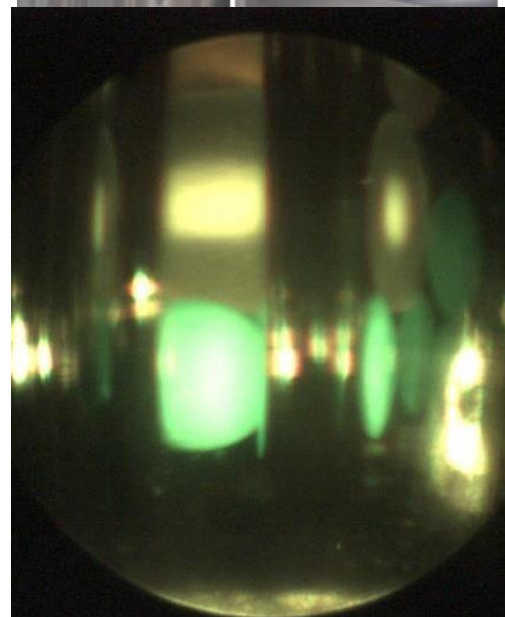
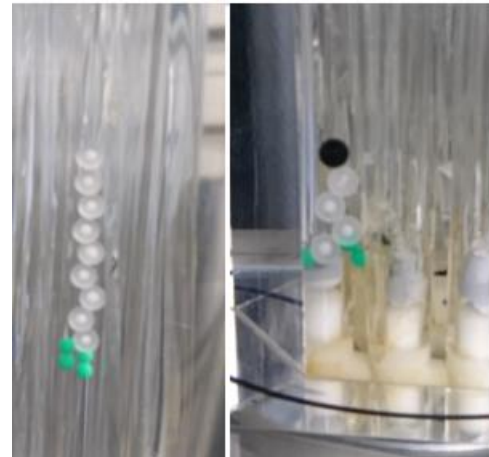

Figure 7: Insertion of 2.0mm particles in green into the pre-blocked test section. Pin fixer (top), wall sub channels (middle) and inner sub channel (bottom)

Insertion of 70 particles with 2.0mm diameter

After the pin fixer and the wall sub channels have been blocked with a total of 180 particles with 3.0mm diameter, the blockage was probed with the insertion of particles with 2.0 mm diameter.

Most of the smaller particles are captured in the pin-fixer by the present 3.0mm particles. 4 particles moved into a pre-blocked wall sub channel and 1 particle was able to enter an inner sub channel and got blocked there. This is shown in Figure 7. During the complete run, a further flow rate decrease and pressure loss increase was measurable and is shown in Table 3. After the run, the complete test section was dismantled, cleaned and investigated. No particle was able to pass the test section. The

Table 3: Flow rate and pressure loss during the first experiment

Particles	20 @ 3.0	160 @ 3.0	20 @ 2.0	Σ
Flow rate decrease	3,5%	19,5%	2,5%	25,5%
Pressure loss increase	1,5%	9%	2,5%	13%

Concluding remarks

The 4 performed experimental series show some predictable but also some new results and insights into the blockage formation in wire wrapped rod bundles.

The first experiment, a blockage using 3.0mm particles that attach at the pin fixer and the wall sub channel followed by smaller 2.0mm particles shows that even with 180 particles not all sub channels are blocked and still smaller particles can pass by. However, they are very likely to attach to the existing big particles. The changes in pressure loss and flow rate are even for this large amount of particles very low.

The second experiment was a blockage using 2.0mm particles that theoretically should be able to pass the pin fixer and the test section. In contrast to the geometrical preconditions several blockages with almost half of the inserted particles was observed.

The third experiment was a blockage using a huge amount of particles that mainly blocked the pin fixer but also formed large axial extended blockages in the wall sub channels. Here, a high influence on flow rate and pressure drop was detected.

The fourth experiment was the use of small 1.5mm particles that easily should pass the pin fixer and the test section but could attach to an existing blockage. Here, it was observed that on the one hand they form temporary blockages that disappear and on the other hand, that no particle attaches to the existing blockage even as the particles were inserted into the same sub channel.

Finally we can conclude from the experiments:

- Most of the measured blockages have a quite small axial extension. The probability of blockage agglomeration with a large axial extension is not very high as the particle size must be large enough not to be able to follow the enhanced crossflow upstream the blockage on the one hand but also must be small enough to meet the geometrical restraints at the pin fixer to enter the sub channel.
- All particle sizes from 1.5mm form blockages
- Existing Blockages enhance crossflow and reduce agglomeration of small particles
- 1.5mm particles are able to follow the sub channel crossflow, the 2.0mm particles aren't and agglomerate on a existing blockage.

Acknowledgements

This project has received funding from the European Union's Horizon 2020 research and innovation programme under grant agreement No 662186. Project Myrte (MYRRHA Research and Transmutation Endeavour).

References

- [1] Schultheiß, G. (1976). Analyse der Bildung lokaler Kühlungsstörungen in schnellen natriumgekühlten Brutreaktoren. Technical Report KFK 2331, Gesellschaft für Kernforschung mbH., Karlsruhe.
- [2] Schultheiß, G. (1977). Model for formation and growth of local blockages in grid spaced fast sodium cooled breeder fuel elements. Nuclear Engineering and Design 43 (2), 329 – 341.

[3] Van Tichelen, K. (2012, December). Blockages in LMFR fuel assemblies. Literature review. Technical Report SCK•CEN-R-5433, SCK•CEN.

[4] Litfin, K. (2009) Final report for the fuel bundle experiment in KALLA, EU-Project EUROTRANS, Contract no.: FI6W-CT2004-516520, Domain DM4 DEMETRA, Deliverable D4.68

[5] Biernath, J. (2015) Bildung von Hindernissen durch Ansammlung von Partikeln in einer Strömung entlang eines Stabbündels: Planung eines experimentellen Aufbaus zur Charakterisierung der Messtechnik. Masterarbeit, Karlsruhe Institute of Technology

[6] Klupp, J. (2018) Charakterisierung von Partikelablagerungen in einem Stabbündel. Bachelorarbeit, Duale Hochschule Baden-Württemberg, Karlsruhe

[7] Litfin, K. (2019) Final report on the KALLA blockage formation test results, EU Project Myrte, Contract no.: 662186, Deliverable D3.24