



The University of
Nottingham

UNITED KINGDOM • CHINA • MALAYSIA

Shaikh, Shakil Ahmed (2015) Investigating the effects of physical and cognitive demands on quality of performance and subjective responses under pacing/takt time. PhD thesis, University of Nottingham.

Access from the University of Nottingham repository:

<http://eprints.nottingham.ac.uk/28776/1/ShaikhFullPhDThesis1.pdf>

Copyright and reuse:

The Nottingham ePrints service makes this work by researchers of the University of Nottingham available open access under the following conditions.

This article is made available under the University of Nottingham End User licence and may be reused according to the conditions of the licence. For more details see:
http://eprints.nottingham.ac.uk/end_user_agreement.pdf

A note on versions:

The version presented here may differ from the published version or from the version of record. If you wish to cite this item you are advised to consult the publisher's version. Please see the repository url above for details on accessing the published version and note that access may require a subscription.

For more information, please contact eprints@nottingham.ac.uk



The University of
Nottingham

UNITED KINGDOM • CHINA • MALAYSIA

**INVESTIGATING THE EFFECTS OF PHYSICAL AND COGNITIVE
DEMANDS ON QUALITY OF PERFORMANCE AND SUBJECTIVE
RESPONSES UNDER PACING/TAKT TIME**

BY

SHAKIL AHMED SHAIKH

**Thesis submitted to the University of Nottingham for the degree
of Doctor of Philosophy**

2015

Abstract

Assembly work requires high levels of performance and quality but may involve complex cognitive and physical tasks. There is evidence that physical and cognitive workloads are not separate, but may interact. Work in exercise and simple physical tasks suggests that physical load may lead to changes in cognitive performance, and in perceived workload. The aim of this thesis is to examine physical and cognitive interactions that might affect assembly work.

First, observation was undertaken in industry to identify the physical and cognitive factors relevant to examples of assembly lines. From this, a task analysis of a simulated assembly task was developed. Three experimental studies were conducted, based upon the simulated assembly task, in order to investigate three main assembly variables; working height, memory load and pacing. The first study showed that the number of completed assemblies was reduced when performed at higher pacing and while working at above shoulder height. The number of components dropped was higher when performed at above shoulder height. When the task was performed at elbow height 'wait' time increased as the beep time was found to be higher at elbow height than the above shoulder height, which led to increase wait time when performing the task at elbow height. Subjective measures (NASA TLX) showed that temporal demand and effort were reported as higher during high pacing. Perceived physical and temporal demand increased when working above shoulder height. An interaction on subjective measure was identified between pacing and working height. Performance of NASA TLX was found to be poor when performing the assembly operation at high pacing/Takt and above shoulder height as compared to working at high pacing/ Takt and elbow height.

In the second study the experimental design was modified by changing the assembly order to variable assembly and consistent assembly, which represented single model assembly line (where only one type of assembly is being processed) and mixed model assembly line (different types of products being processed). Study 2 was found to be more mentally demanding due to task complexity. However, it was also found that completed assemblies were higher for the consistent assembly task. Subjective measures reported stress as being higher for higher pacing and variable assembly.

The final study combined the variables from the first two studies as well as investigating different levels of memory load. Performance times for variable assembly were longer and resulted in less correct code responses. A higher memory load resulted in a higher performance time and lower correct code responses as well as fewer completed assemblies. An interaction between working height and perceived mental workload was found. Results showed that perceived temporal demand and perceived effort of NASA TLX were found to be higher when performing the assembly operation at elbow height and high memory as compared to the assembly operation performed at elbow height and low memory. It was also found that memory load affects perceived physical demand.

For industry the findings suggest that in variable (mixed model) assembly different levels of pacing, working height and cognitive demands may affect workers' performance both physically and mentally. Demands will be higher when working at variable assembly but also performance will vary where variable and consistent assembly are used together. The research also discusses theories that might be most useful for describing these effects.

Acknowledgements

First of all, Thanks to Allah Almighty for enabling me complete this research.

I would like to offer my special thanks to my supervisors Dr. Sue Cobb, Dr. David Golightly, Dr. Christine Haslegrave and Dr. Joel Segal: I would not have been able to complete this work without their help and guidance.

I would thank to my loving wife who encouraged me at every stage of my PhD work. Also thanks to my friends for having good companies and visits to different places of UK.

Thanks to Sarah Sharples, Mirabelle DCruz, Richard Eastgate, Glyn Lawson, Alyson Langley and Harshada Patel who involved me in a ManuVAR project that gave some weight to my PhD.

Thanks to Kirstie Dane and Anne Floyd for their administrative support. A great thanks to the Human Factors Research Group: Christmas parties and away days would always be the memorable events.

Table of Contents

Abstract	ii
Acknowledgements	iv
1 Introduction	1
1.1 Background.....	1
1.2 Research Aims and Objectives	5
1.2.1 Aim.....	5
1.3 Objectives	5
1.4 Organisation of thesis	6
2 Literature Review	8
2.1 Introduction	8
2.2 Assembly tasks	8
2.2.1 Ergonomics Research into Assembly.....	10
2.2.2 Design for Assembly and assembly complexity.....	11
2.2.3 Summary	13
2.3 Physical characteristics related to assembly task	13
2.3.1 Physiology and anatomy of posture & task demands	14
2.3.2 Anthropometrics of the work place	15
2.3.3 Repetitive tasks.....	18
2.3.4 Fatigue	19
2.3.5 Summary	21
2.4 Cognition and assembly tasks	21
2.4.1 Assembly complexity.....	23
2.4.2 Mental Workload and assembly.....	23
2.4.3 Summary	25
2.5 Pacing.....	25

2.5.1	Effects of pacing/ Takt on physical and cognitive performance	26
2.5.2	Summary	28
2.6	Physical and Mental Workload Interaction	28
2.7	Theoretical explanations of interactions	30
2.7.1	Armstrong Model of WRULDs.....	31
2.7.2	Single and Multiple Resource Models (MRM).....	34
2.7.3	Summary	38
2.8	Research questions	38
3	Familiarisation and understanding of assembly tasks.....	41
3.1	Introduction	41
3.2	Background.....	42
3.3	Industry visits.....	44
3.3.1	Plant A - Automobile assembly.....	45
3.3.2	Plant B – Aero-engine assembly	49
3.3.3	Plant C – Industrial vehicle assembly	51
3.3.4	Plant D - Mineral equipment manufacture.....	53
3.4	Discussion	58
3.4.1	Developing a task analysis	61
3.5	Conclusion.....	67
4	Methodology.....	69
4.1	Introduction	69
4.2	Background.....	69
4.3	Experimental Setup	71
4.4	Independent Variables.....	79
4.4.1	Physical demand.....	79
4.4.2	Cognitive Demand	80

4.4.3	Pacing	81
4.5	Dependent Variables.....	82
4.5.1	Objective measures - Performance.....	82
4.5.2	Subjective measures - Physical and mental workload.....	84
4.6	Relation with theory	86
4.7	Summary	87
5	Study 1- Investigating effects of physical and cognitive demands under different pacing levels	89
5.1	Introduction	89
5.2	Experimental hypotheses	90
5.3	Task Analysis.....	91
5.4	Method	93
5.4.1	Participants	93
5.4.2	Experimental design	93
5.4.3	Independent Variables	96
5.4.4	Procedure.....	98
5.4.5	Instructions to the participant.....	98
5.4.6	Dependent Measures	101
5.4.7	Statistical analysis.....	101
5.4.8	Test for Assumptions.....	101
5.5	Results	102
5.5.1	Objective measures	102
5.5.2	Subjective measures.....	112
5.6	Main findings of Study 1	123
5.7	Discussion of Experiment 1	127
5.8	Summary	130

6	Study 2 - Investigation of the effects of assembly order (Variable assembly and consistent assembly) in relation to cognitive and physical demands	131
6.1	Introduction	131
6.2	Task Analysis	132
6.3	Experimental design	134
6.3.1	Participants	134
6.3.2	Independent Variables	134
6.3.3	Presentation of assembly order	134
6.3.4	Dependent Variables	137
6.3.5	Procedure	137
6.3.6	Instructions to the participants	139
6.3.7	Test for Assumptions	140
6.4	Results	140
6.4.1	Objective measures	141
6.4.2	Subjective Measures	148
6.5	Main Findings of study 2	157
6.6	Discussion	161
6.7	Summary	164
7	Study 3 – Cognitive load and high pacing / Takt	166
7.1	Introduction	166
7.2	Experimental design and Task Analysis	166
7.3	Method	170
7.3.1	Participants	170
7.3.2	Procedure	170
7.3.3	Independent Variables	173

7.3.4	Dependent Variables	175
7.4	Results	176
7.4.1	Test for assumption and results	176
7.4.2	Objective measures	177
7.4.3	Subjective Measures	183
7.5	Main findings of study 3	192
7.6	Discussion	195
7.1.	Summary	197
8	Discussion	198
8.1	Introduction	198
8.2	Objective measures.....	199
8.2.1	Effect of pacing on the objective measures	199
8.2.2	Effect of work height on the objective measures	201
8.2.3	Effect of memory on the objective measures	203
8.3	Subjective Measures	205
8.3.1	Effects of pacing on the dimension of NASAL TLX.....	205
8.3.2	Effects of work height on NASA TLX dimensions.....	207
8.3.3	Effects of memory load on NASA TLX dimensions	208
8.3.4	Fatigue	209
8.3.5	Stress and Arousal	210
8.4	Interactions	210
8.4.1	Interaction between pacing and work height on number of completed assemblies.....	210
8.4.2	Interaction between pacing and work height on number of completed assemblies.....	211

8.4.3	Interaction between pacing and assembly variability on number of completed assemblies	212
8.4.4	Interaction between assembly variability and memory load on assembly time.....	213
8.4.5	Interaction between work height and memory load on number of dropped nuts and bolts	214
8.5	Theory	214
8.6	Summary.....	219
9	Conclusion	221
9.1	Introduction	221
9.2	Contribution to aims and objectives	221
9.3	Limitations and recommendations for Future work.....	229
	References.....	231
	Appendix 1 Subject Information Sheet for Study 1	241
	Appendix 2 Subject Information Sheet for Study 2	243
	Appendix 3 Subject Information Sheet for Study 3	245
	Appendix 4 General Well-Being Questionnaire.....	247
	Appendix 5 Workload Check list.....	248
	Appendix 6 Physical Well-Being Checklist Questionnaire	250
	Appendix 7 Stress and Arousal Checklist	252
	Appendix 8 Observational Check list.....	254
	Appendix 9 Observation Protocol for ManuVAR Tasks.....	255

List of Figures

Figure 2-1: Working height for particular task	17
Figure 2-2: Working height for tasks at above shoulder height	17
Figure 2-3: The model for development of WRULDs proposed by Armstrong et al., (1993)	32
Figure 2-4: Multiple resources model by Wickens, 2002	36
Figure 3-1: Task carried out at shoulder height	57
Figure 3-2: Complex task carried at stationary assembly	57
Figure 3-3: Pictorial view of task observed at plant A	64
Figure 3-4: Task analysis of workstation assembly	66
Figure 4-1: Hierarchical task analysis for the simulated assembly operation ..	76
Figure 4-2: Complete set up of single assembly operation	76
Figure 4-3: Computer Application design	77
Figure 5-1: Hierarchical task analysis for the simulated assembly task.....	92
Figure 5-2: Task performance at computer and at assembly.....	94
Figure 5-2 A: Getting code for the assembly	94
Figure 5-2 B: Presses Red key before start the assembly	94
Figure 5-3 A: Performing assembly at above shoulder height	95
Figure 5-3 B: Performing assembly at elbow height	95
Figure 5-4 Sequence of procedure	100
Figure 5-4: Mean and Standard error of assembly time for each of the 12 conditions in assembly task	103
Figure 5-5 Mean (SE) of number of correct code responses of 12 conditions of assembly task.	105
Figure 5-6: Mean (S.E) of number of completed assemblies of each of the 12 conditions in assembly task	107
Figure 5-7: Mean (S.E) of dropped nuts and bolts in each condition of assembly task	109
Figure 5-8: Mean walking time (in seconds) for each of the 12 conditions in assembly task	111

Figure 5-9: Means and standard errors of the perceived mental demand in the different task conditions of the assembly task	113
Figure: 5-10 Means and standard errors of the perceived physical demand in the different task conditions of the assembly task	114
Figure 5-11: Means and standard errors of the perceived temporal demand in the different task conditions of the assembly task	116
Figure 5-12: Mean and S.E of perceived performance for each of the 12 conditions in assembly tasks.....	118
Figure 5-12: Mean and SD of perceived Effort for each of the 12 conditions in assembly tasks.....	120
Figure 5-13: Mean and S.E of perceived Effort for each of the 12 conditions in assembly tasks.....	120
Figure 6-1: Hierarchical task analysis for the simulated assembly task for experiment 2	133
Figure 6-2: Presentation of Assembly order	136
Figure 6-3: Sequence of experimental procedure.....	138
Figure 6-4: Mean and SE of assembly time for each of the 8 conditions in assembly task	142
Figure 6-5: Mean and standard error of completed assemblies for each of the 8 condition in assembly task	144
Figure 6-6: Mean and standard error of correct code responses for each of the 8 conditions in assembly task.....	145
Figure 6-7: Mean and standard error of number of drops for each of the 8 conditions in assembly task	146
Figure 6-8: Mean and standard error of each condition of mental demand .	149
Figure 6-9: Mean and standard error of Physical demand for each condition of physical demand.....	150
Figure 6-10: Mean and standard error of temporal demand for each of the 8 conditions in assembly task	151
Figure 6-11: Mean and SE of Perceived performance for each of 8 conditions in assembly task	152

Figure 6-12: Mean and SE of Perceived Effort for each of 8 conditions in assembly task	153
Figure 6-13: Mean and SE of Stress score for each of the 8 conditions in assembly task	154
Figure 6-14 : Mean and SE of Arousal for each of the 8 conditions in assembly task.....	155
Figure 7-1 (overleaf): Hierarchical task analysis for the simulated assembly task in study 3	168
Figure 7-2: Experimental design with two levels for each of three independent variables in assembly task	169
Figure7-3: Sequence of procedure	172
Figure 7-4: Mean (S.E) of assembly time for each condition of 12 conditions in assembly tasks	178
Figure 7-5: Mean number of correct code responses for each of the 12 condition in assembly task.....	180
Figure 7-6: Mean number of completed assemblies for each of the 12 conditions in assembly task	181
Figure 7-7: Mean number of dropped nuts and bolts for each of the 12 condition in assembly task.....	182
Figure 7-8: Mean and SE of perceived mental demand (0 low and 20 high) 12 conditions in assembly task	183
Figure 7-9: Mean and SE of perceived physical demand (0 low and 20 high) 12 conditions in assembly task	184
Figure 7-10: Mean and SE of perceived temporal demand (0 low and 20 high) 12 conditions in assembly task	185
Figure 7-11: Mean and SE of perceived performance (0 perfect and 20 failure) 12 conditions in assembly task	186
Figure 7-12: Mean and SE of perceived effort (0 low and 20 high) 12 conditions in assembly task	188
Figure 7-13: Mean and SE of perceived fatigue (0 low and 20 high) 12 conditions in assembly task	189

Figure 7-14: Mean and SE of perceived stress for 12 conditions in assembly task.....	190
Figure 8-1: Interaction between pacing work height on number of completed assemblies	211
Figure 8-2: Interaction between pacing and assembly order on number of completed assemblies	212
Figure 8-3: Interaction between assembly variability and work height on assembly time	213
Figure 8-4: Interaction between work height and memory load on number of dropped nuts and bolts.....	214
Figure 8-5: Task environment sub-system components (Marras and Hancock, 2014).....	219

List of Tables

Table 3-1: Observation of assembly tasks under physical and cognitive factors	63
Table 5-1: Independent variables	97
Table 5-3: Mean(SD) of each condition on Assembly time	103
Table 5-4: Mean(SD) of each condition on correct code responses	105
Table 5-5: Mean(SD) of each condition on number of fully completed assemblies	107
Table 5-6: Mean(SD) of each condition on number of number of dropped nuts and bolts	109
Table 5-17: Mean(SD) of each condition on number of Walk time between assembly and computer display	111
Table 5-8: Mean (SD) of each condition of mental demand	113
Table 5-9: Mean (SD) of each condition of perceived physical demand	114
Table 5-10: Mean (SD) of each condition of perceived physical demand	116
Table 5-11: Mean (SD) of perceived performance for each of the 12 conditions in assembly task.	118
Table 5-13: Mean and SD of perceived Fatigue for each of the 12 conditions in assembly tasks.....	121
Table 5-14: Mean and standard deviation for each condition of Stress score in assembly task	122
Table 5-15: Mean and standard deviation for each condition of Arousal score in assembly task	122
Table 5-17: Results of analysis of variance for the objective measures (with significant effects indicated in bold).....	125
Table 5-18 Results of analysis of variance for the subjective measures* p <0.05, ** p<0.01.....	126
Table 6-1: Mean (SD) of assembly time for each of the 8 conditions in assembly task	142

Table 6-2: Mean (SD) of completed assembly for each of the 8 conditions in assembly task	144
Table 6-3: Mean (SD) of correct responses for each of the 8 conditions in assembly task	145
Table 6-4: Mean (SD) of dropped nuts and bolts for each of the 8 conditions in assembly task	146
Table 6-5: Mean (S.E) of interaction between pacing and work height for walk time	147
Table 6-6: Mean (SD) of perceived mental demand for each of the 8 conditions in assembly task	149
Table 6-7: Mean (SD) of perceived physical demand for each of the 8 conditions in assembly task	150
Table 6-8: Mean (SD) of perceived temporal demand for each of the 8 conditions in assembly task	151
Table 6-9: Mean (SD) of perceived performance for each of the 8 conditions in assembly task	152
Table 6-10: Mean (SD) of perceived effort for each of the 8 conditions in assembly task	153
Table 6-11: Mean (SD) of stress score for each of the 8 conditions in assembly task.....	154
Table 6-12: Mean (SD) of arousal score for each of the 8 conditions in assembly task	155
Table 6-13: Mean (SD) of perceived fatigue for each of the 8 conditions in assembly task	156
Table 6-14: Summary results of the ANOVAs for objective measures	159
Table 6-15 Overlead: Summary results of the ANOVAs for subjective measures	160
Table 7-1: Levels of independent variable	174
Table 7-2: Mean (SD) of assembly time for each of the 12 conditions in assembly task	178
Table 7-3: Mean (SD) of correct responses for each of the 12 conditions in assembly task	180

Table 7-4: Mean (SD) of completed assemblies for each of the 12 conditions in assembly task	181
Table 7-5: Mean (SD) of number of drops for each of the 12 conditions in assembly task	182
Table 7-6: Mean (SD) of perceived mental demand for each of the 12 conditions in assembly task	183
Table Mean 7-7: (SD) of perceived physical demand for each of the 12 conditions in assembly task	184
Table 7-8: Mean (SD) of perceived temporal demand for each of the 12 conditions in assembly task	185
Table 7-9: Mean (SD) of perceived performance demand for each of the 12 conditions in assembly task	186
Table 7-10: Mean (SD) of perceived effort for each of the 12 conditions in assembly task	188
Table 7-11: Mean (SD) of perceived fatigue demand for each of the 12 conditions in assembly task	189
Table 7-12: Mean (SD) of perceived stress for each of the 12 conditions in assembly task	190
Table 7-13: Mean (SD) of perceived stress for each of the 12 conditions in assembly task	191
Table 7-14: Summary of the ANOVA s for objective measures.....	193
Table 7-15: Summary of the ANOVA s for Subjective measures.....	194
Table 8-1: Effects of pacing/ Takt levels on objective measures	200
Table 8-2: Effects of work height levels on objective measures	202
Table 8-3: Effects of Memory on objective measures	203
Table 8-4: Effects of pacing/ Takt levels on NASA TLX dimensions.....	205
Table 8-5: Effects of work height on NASA TLX responses	207
Table 8-6: Effects of memory on NASA TLX responses	208
Table 8-7: Relationship between exposure, dose, capacity and response	215

1 Introduction

1.1 Background

Different manufacturing methodologies are being explored and implemented in order to improve productivity and quality, while keeping the ergonomic characteristics of work as a consideration. Increasing research in the field of ergonomics, according to Hag (2003), has provided a great deal of knowledge (e.g. design of tools, workstation and organization design) to reduce fatigue and injury in order to improve productivity and quality. However, the risk of work related musculoskeletal disorders, especially, upper limb work related musculoskeletal (UL-WMS) disorders, is still present with organisations reporting problems of poor quality, productivity and occupational health and safety of their workers (Genaidy and Karwowski, 2003). According to NIOSH (National institute of occupational safety and health) and the National Research Council and Institute of Medicine (2001), work related musculoskeletal disorders (WMSD) injuries are common problems in the manufacturing environment. A survey conducted by the European Agency for Safety and Health at Work (EASHW, 2000) states that more than 600 million working days are lost each year due to work related ill health, resulting in an economic cost of up to 3.8% of the gross national product and 40-50% of this cost is attributable to work related musculoskeletal disorders (EASHW, 2000). It has also been observed that work related injuries and illness have been major social problems due to costs related to labour turnover, absenteeism, defective goods, and reduced productivity (Neumannr et al., 2002).

Assembly operations at workstations in paced assembly lines (Aase et al., 2004) have been widely studied in the literature (Lin et al., 2001, Drury, 2000). Generally workstation operations involve physically and cognitively demanding tasks, which consequently impose physical and mental stresses.

Features common to many assembly tasks include awkward postures, use of hands in manipulating components and tools, memorising defined procedures and component part numbers, rapid information processing and decision making, and control of task completion time by some form of pacing (Bosch et al., 2011, Delbridge et al., 2000).

Also, the Takt time system is a lean manufacturing tool that is widely used for controlling assembly work. It imposes a form of pacing on the assembly line (through a set target assembly completion time, which can vary according to the order book or customer demands). Takt time is defined as the maximum time allowed for producing a product in order to meet the customer demand (Womack et al., 1990). Every stage and task in the production process is controlled by the Takt time specified. This Takt time is then broken down to give a maximum time for performing each task involved in the production of that product. The effect on the shop floor operators is to define the required pace of work. Lean manufacturing tends to lead to a short cycle, highly repetitive system. Some researchers report that techniques such as lean manufacturing may increase injury prevalence and mental workload as a result of intensified work demands and reduced job control (Landsbergis et al., 1999).

Workstation tasks at moving assembly lines, tasks related to time pressure, awkward postures, and information processing and decision making, can result in both increased physical and mental stresses (Chung, et al., 2005; Macdonald and Bendak, 2000), and some research studies have explored the independent impacts of physical or cognitive demands of Takt time on physical and cognitive stresses (Escorpizo and Moore, 2007).

While much research has been carried out on assessing the impacts of physical demands and cognitive demands on working conditions separately, there is less literature available on the simultaneous performance of physically and cognitively demanding tasks. Recent studies have, however, started to explore interactions between these. For example, DiDomenico and Nussbaum (2008), Basahel et al. (2010) and Perry et al. (2008) have examined the interactive effects of physical and cognitive demand on workload assessment using NASA TLX and Borg CR-10. They found that perceived mental activity was affected by introducing physical demands. It was found that when physical activity was introduced, performance at the medium level of mental workload was equivalent to that in the low mental workload condition; furthermore, at the low mental workload, there were no differences in performance between low and medium physical workloads. However, there is not a clear relationship. Also, these studies have typically been performed on simple tasks such as manual handling or basic physical exercise. There is often an effect on perceived workload due to physical tasks, but this is not always seen in objective performance. There is therefore a possible link between this work into combined physical and cognitive workload, but it is not clear what this means for assembly work.

In order to understand the potential relationship between physical and cognitive demands this thesis considers Armstrong's dose-capacity model and Wicken's multiple resource models as a basis to interpret the findings in the experimental studies. Armstrong et al., (1993) presented a conceptual model that demonstrated the relationship between risk factors and musculoskeletal disorders. The model showed how external factors and work demands could cause disturbances depending upon the required capacity. The immediate responses that occur after performing the task could be biomechanical, physiological and psychological. However, there are limitations in the Armstrong model. First, Armstrong et al. (1993) pointed out that there is a relationship between biomechanical and psychological factors, but the authors also said that "quantitative relationships, however, need to be

described in future research” (p. 81). The model discusses psychological responses as being psychosocial (e.g. stress). However, Perry et al (2008) showed that psychological responses may also apply to cognitive performance, such as, situation awareness. Second, the relationship model focuses on physical factors (tools, environment, etc.) as an exposure variable, but cognitive demand might act as a dose that leads to physical response. On the other hand, the 4-dimensional multiple resources model, also known as Wickens’ multiple resource model, hypothesises that there will be greater interference between two tasks to the extent that they share stages (perceptual/cognitive vs response) sensory modalities (auditory vs visual), codes (visual vs spatial) and channels of visual information (focal vs ambient) (Wickens, 2008). According to Wickens (2008), there is evidence that support resource aspects (more difficult tasks cause greater interference) and multiple aspect (structurally similar tasks create more interference). However, research is scarce to fully understand how resource aspects and multiple aspects work together when heterogeneous real world tasks are combined. Both Armstrong et al’s physical and Wickens’ multiple resource models are further discussed in detail in chapter 2

Simultaneous performance of physical and cognitive demanding tasks is prevalent in assembly operations and is continuing to increase due to rapid technology and mass customisation. However, very little laboratory research has been conducted to examine and understand the potential interaction between physical and cognitive demands for assembly. This thesis describes a series of experiments designed to examine how different components of assembly operations when performed simultaneously affect task performance and perceived experience of workload and considers how the dose-capacity model or multiple resource models may explain the results.

1.2 Research Aims and Objectives

1.2.1 Aim

The aim of this research work was to investigate the effects of pacing (such as the imposition of Takt time) on aspects of task performance in assembly work. Specifically, the research aimed to measure perceived workload and perceived stress for an assembly task that demanded both physical and cognitive effort, to investigate whether physical and cognitive demands interact and to investigate their influence.

1.3 Objectives

The objectives of the overall research work were:

- To identify issues related to assembly operations in paced assembly lines
- To investigate the effects of different levels of Takt time on working conditions during simultaneous performance of physical and cognitive demanding tasks
- To determine whether there is an interaction between physical and cognitive demands
- To apply ergonomics methods to evaluate task performance in detail. This was conducted in lab work.
- To examine different theories for the interaction between physical and cognitive demands.

Literature review on assembly tasks, physical and cognitive characteristics and their relationship was carried out to identify gaps in current research work.

The areas that provided relevant information in the literature review (such as Takt time in paced assembly line, mixed model assembly line (product variety), interaction between physical and cognitive demands) were then considered for further investigation. Theoretical approaches including Armstrong et al's dose-capacity model (1991) and Wicken's multiple resource models (2002; 2008) were discussed.

Real assembly tasks were then observed to understand the relationship between the research areas and the current situation, which concluded with the need for research on investigating the relationship between physical (working height) and cognitive (attention, memory) demands in mixed model assembly lines under Takt time. Finally, laboratory studies based on the observations were conducted to analyse the effects of physical and cognitive demands and their interaction on the quality of performance and subjective responses.

1.4 Organisation of thesis

The thesis consists of nine chapters as follows:

Chapter 1: Introduction

This chapter discusses the background, research focus, aims and structure of the research.

Chapter 2: Literature Review

The chapter presents a review of literature in several areas supporting an understanding of the nature of assembly task operations in manufacturing industry, ergonomic evaluation of the impact of assembly tasks on operators, specifically with regard to physical and cognitive demands, and theoretical models that may be used to explain interactions between these demands. .

Chapter 3: Familiarisation and understanding of assembly tasks

This chapter describes a number of visits made to manufacturing companies in the UK and Europe. These were used to provide an understanding of the real working environment of assembly line operators and to select representative tasks that could be conducted in laboratory studies.

Chapter 4: Research Methodology

This chapter presents the research methodology applied including design of experimental studies and use of methods to assess physical and cognitive demand.

Chapter 5: Study 1

This chapter describes the first experimental study which investigated the effects on performance of concurrent physical and cognitive demands under three different pacing levels

Chapter 6: Study 2

Based on the results achieved from study 1, study 2 was designed with some modification. This chapter describes the second experimental study which investigated the effects of assembly order (variable assembly and consistent assembly) in relation to cognitive and physical demands

Chapter 7: Study 3

Based on the findings from studies 1 and 2, study 3 was designed with the aim of understanding the particular effects of different variables on physical load. This chapter describes the design and analysis of study 3.

Chapter 8: Discussion

Overall analysis and findings from all of the experiments are discussed in this chapter. The findings are compared with the previous literature in order to evaluate the effectiveness of the present research specific to two theoretical models, Armstrong (1993) dose-capacity model and Wickens (2002) multiple resource model.

Chapter 9 Conclusions and Recommendations

This Chapter discusses the contribution to the aims and objectives of the research and the implications of the findings. .

2 Literature Review

2.1 Introduction

Chapter 2 introduces the research background for this thesis. Since the thesis covers assembly line operations involving physical and cognitive components, the literature review is presented in several stages. Section 2.2 discusses assembly tasks characteristics, design for assembly and ergonomics research into assembly operations. Section 2.3 presents work on the physical characteristics of task demands including physiology and anatomy of posture, and anthropometrics related to physical task performance in assembly lines. Section 2.4 presents cognitive characteristics of task demands including complex assembly, mental workload, and memory. Section 2.5 covers pacing in assembly. Section 2.6 covers existing work on interactions between physical and cognitive demands. Section 2.7 presents theoretical explanations of how there is a link between physical and cognitive demands, and how this might apply to assembly work. This identifies gaps in literature which form the research questions addressed in this thesis. These research questions are presented at the end of the chapter.

2.2 Assembly tasks

Assembly is the process of integrating parts into a final product. Stobel et al., (2008) describe the sequence of steps that normally occur during manual assembly, which include the identification of type and part number of a work piece from the instruction. The next step is memorising the form, colour and/or number of the part to be selected. The respective part location (where the parts are stored) is then found and finally the relevant action or response (e.g, grasping, fastening assembly with the left or right hand) has to be selected and executed. These sub-activities are a necessary requirement to perform the assembly task and need to be supported adequately, especially in

highly demanding settings where products are required to be produced within a fixed time period.

Richardson et al. (2004; 2006) describe two types of assembly task; self-assembly and manufacturing assembly. Self-assembly is defined as assembly of an object or household equipment that people assemble in their homes. Self-assembly tends to be carried out in one-off tasks without training, whereas manufacturing assembly involves a greater volume of repetition and potentially training given to operators.

Moreover, manufacturing assembly or industrial tasks have been further categorised into automatic assembly (where tasks are done by the machine or motor), semi-automated or machine-paced (where tasks are shared by machine (e.g. conveyor) and a worker), and manual assembly, which is only performed by the worker (Lin et al., 2001). Machine-paced assembly has also been termed as Takt time in lean manufacturing (Womack and Jones, 2007). It has been pointed out that pace-wise, both fully automatic and manual assembly tasks are not as problematic and physically demanding as semi-automatic assembly where machines determine the pace of work, which has to be strictly followed by the worker with possible risk of increasing work related musculoskeletal disorders (WMSDs) (Escorpizo and Moore, 2007).

Manufacturing assembly tasks, which are carried out on assembly lines, often involve simultaneous performance of both physical and cognitive sub-tasks. Physical sub-tasks might include lifting, fixing and fastening, or may involve awkward postures (Sood et al., 2007). Cognitive sub-tasks might include memory for assembly instructions, or attention to which model or product is being assembled when different products are on the same assembly line (Zhu et al., 2008). This includes a link between cognitive workload and assembly

complexity (Richardson et al., 2004, 2006). Therefore, this section discusses the manufacturing assembly task from different perspectives, which include ergonomics research into assembly, design for assembly and manufacturing, mixed model assembly, assembly in lean manufacturing. Physical and cognitive characteristics and their relationships involved in assembly operations are discussed in later sections.

2.2.1 Ergonomics Research into Assembly

The implementation of ergonomics has been widely applied in assembly in order to achieve success in improving performance, productivity, competitiveness, health and safety (Smith, 2007). Over the years the objectives of ergonomics have grown to encompass the design of work systems, for example equipment, material, tools, and environment etc., so that tasks can be performed within human capabilities in mind so as to improve productivity and reduce injuries and fatigue. Concepts from different fields, for example, industrial engineering, mechanical engineering, medicine etc., have considerable influence within the field of ergonomics particularly with regards to working smarter, not harder, elimination of waste, and maintaining a systems view that includes economic impact (Dul & Neuman, 2009; Wang et al., 2007; Brenner, 2004).

Existing ergonomics research into assembly is mainly concerned with production/ assembly line environments and issues relating to workers' health and productivity (Grandjean and Kroemer, 1997). However, current trends in assembly task operation result from increased demands for product variety due to a shift towards mass customisation (Hu et al., 2011). Assembly lines that handle multiple products are called Mixed Model Assembly Lines (MMAL), and have forced researchers, production designers and engineers to design and operate assembly systems in such a way as to handle product variety (Xiaowei et al., 2008).

In modern manufacturing assembly work there are many demands for work to be completed in accordance with fixed speed rates (pacing), timeliness (working to deadlines), whilst also maintaining quality. Lean manufacturing is one of the manufacturing methodologies that has proved very successful in improving productivity and quality (Shah and Ward, 2003). It is a system of identifying sources of waste and reducing them by the application of lean tools and techniques. For example, the Takt time system is a lean manufacturing tool that is widely used for controlling assembly work. It imposes a form of pacing on the assembly line, through a set target assembly completion time, which can vary according to the order book or customer demands). Takt time is defined as the maximum time allowed for producing a product in order to meet the customer demand (Womack et al., 1990). Every stage and task in the production process is controlled by the Takt time specified. This Takt time is then broken down to give a maximum time for performing each task involved in the production of that product. The effect on the shop floor operator is to define the required pace of work. However, there is evidence that high pacing has a negative effect on operators and therefore on performance and quality (Escorpizo and Moore, 2007; Bosch, 2011).

2.2.2 Design for Assembly and assembly complexity

Complexity is considered as one of the main difficulties of handling or insertion processes in manual or automatic assembly (Samy and El Maraghy, 2010). Therefore, it is important to consider manufacturing and assembly methods during product design in order to reduce or avoid task complexity and optimise production cost and productivity.

In this regard, design for assembly (DFA) and design for manufacturing (DFM) are tools to assist in the design and manufacturing of products at a minimum cost. Design for assembly (DFA) is defined as the method of design of product

for ease of assembly, whereas design for manufacturing (DFM) is defined as the method of design for the ease of manufacturing of the collection of parts.

The process of manual assembly can be naturally divided into two areas: handling (acquiring, orienting and moving the parts) and insertion and fastening (mating a part to another part or group of parts). Boothroyd et al. (2011, p.74) make the following recommendations for manual assembly:

Design guidelines for part handling

- Design parts that have end to end symmetry and rotational symmetry about the axis of insertion. If this cannot be achieved, try to design parts having maximum possible symmetry.
- Design parts that, in those instances in which a part cannot be made symmetric, are obviously asymmetric.
- Provide features that will prevent jamming of parts that tend to nest or stack when stored in bulk.
- Avoid parts that stick together or are slippery, delicate, flexible, very small or very large, or that are hazardous to the handler (i.e., parts that are sharp, splinter easily, etc.)

Design guidelines for insertion and fastening

- Design so that there is a little or no resistance to the insertion and provide chamfers to guide the insertion of two mating parts. Generous clearance should be provided, but care must be taken to avoid clearance that result in a tendency for parts to jam or hang-up during insertion.
- Standardize by using common parts, processes, and methods across all models and even across product lines to permit the use of higher volume processes that normally results in lower product cost.

- Use pyramid assembly—provide for progressive assembly about one axis of reference. In general, it is best to assemble from above.

Richardson et al. (2004) identified seven physical characteristics of assembly: selection, symmetrical planes, fastening, fastening points, components, novel assemblies, and component groups. Of these, symmetrical planes, fastening, fastening points and components, were shown to be successful predictors for thinking time (Richardson et al., 2006). However, as these characteristics were derived from analysis of one-off assemblies and not for manufacturing assemblies, it is not clear how much these relate to the physical characteristics of the assembly, or the cognitive characteristics of the assembler in a manufacturing context.

2.2.3 Summary

This section has introduced assembly tasks. Some important factors for assembly have been introduced here, which will be discussed further in this introduction and in the rest of this thesis. These are Takt time and semi-automatic assembly which together form many modern paced assembly lines. Also, product variety was introduced which forms many mixed model assembly lines. The importance of assembly design was also introduced. Within assembly there are many potential physical and cognitive demands. These are discussed further in the next sections.

2.3 Physical characteristics related to assembly task

In terms of physical elements of assembly work the performance of manufacturing assembly tasks often involves ergonomics issues related to working postures, material handling, repetitive movements, work related musculoskeletal disorders, workplace layout, safety and health. These areas fall under what is routinely described as ‘physical ergonomics’. The International Ergonomics Association (2000) defines physical ergonomics as, “concerned with human anatomical, anthropometric, physiological and biomechanical characteristics as they relate to physical activity”.

Research on identifying the impacts of physical attributes on performance is not new. Walker and Guest (1952) pointed out that assembly line work included mechanical pacing, repetitiveness, low skill requirement, performance of tiny fractions of the product, limited social interactions and predetermination of tools and techniques. In manufacturing industry today these factors are still major issues for assembly line workers who face problems of fatigue and discomfort that may eventually result in musculoskeletal disorders. Thus, the following sections review relevant ergonomics literature to understand the physical elements of assembly work.

2.3.1 Physiology and anatomy of posture & task demands

Posture is mostly adopted to deal with the workplace and surrounding environments and is considered as an important contributor to healthy and effective activity. Working posture can be determined by the relationship between the dimensions of the body and those of the workstation.

Workstation design and equipment affect the postures which will commonly be adopted by the operators. Such postures may not necessarily be the best posture for the task performed. Many researchers have discovered a significant relationship between workstation design or postures and the incidence of discomfort and musculo-skeletal disorders (Grandjean, et al. 1983).

Overhead work has been of considerable interest to researchers and is identified as a major occupational risk. A number of studies have been carried out related to musculoskeletal disorders especially neck and shoulders (Haslegrave, 1990). Several risk factors may contribute to upper activity discomfort, including task repetition, high hand force, awkward postures and prolonged constrained postures (Rempel et al. 1992). Herberts and Kadfers (1976) pointed out that prolonged activity in overhead working postures may create strain and fatigue on shoulder muscles. Evidences also show postural

discomfort when arms are required to work above shoulder height (Svendson et al., 2004; Miranda, 2005). Even though there is a strong association between over head work and musculoskeletal disorders, it is sometimes difficult to avoid these postures in practice. However, in industrial tasks that require arm elevation above shoulder height, flexibility and movement, instead of static postures, will help (Karwowski and Waldemar, 2011).

The literature discussed above on working posture demonstrates the association between awkward postures and development of musculoskeletal disorders. However, much of the literature in this area is not new and many of the studies were conducted in the context of traditional assembly task performance. Therefore, there is a need to re-study/ re-analyse the working posture keeping into considering the current situations, which include demand for product variety, mixed model assembly line system, fixed pacing/ Takt time as the novelty of this research.

2.3.2 Anthropometrics of the work place

The physical dimensions in the design of manufacturing workstations are of major importance from the view point of production efficiency and operator physical and mental well-being. Small changes in workstation dimensions can have considerable impact on worker productivity and occupational health and safety. Inadequate posture caused by an improperly designed workstation causes static muscle efforts, eventually resulting in acute localised muscle fatigue. Consequently, it decreases productivity and increases possibility of operator related health hazards.

For the design of workstations, Karwowski and Waldemar (2011) determined dimensions by using existing anthropometric data, so that these could be readily employed by a designer. For the physical design of a manufacturing workstation, the four essential design dimensions are;

- work height,
- normal and maximum reaches,
- lateral clearance, and
- angle of vision and eye height.

Work height is of critical importance. Research has identified many problems related to musculoskeletal disorders due to improper design of workplaces or not considering anthropometric data. For example, if the work is too high, the shoulders must frequently be lifted up, which may lead to discomfort, and pain in the neck and shoulders. Similarly, if the work is too low, the lower back will suffer and may cause backache. Apart from issues related to musculoskeletal disorders, research has also identified consequences for related delay in task completion, increased number of drops, general fatigue due to working at different heights (Bosch et al. 2011; Escorpizo and Moore, 2007; Sood et al, 2007). Therefore, it is recommended that the work surface must be of such height that the operator finds it comfortable to perform the task, whether standing or sitting.

Figure 2.1 (Kroemer and Grnadjean, 1997) and 2.2 (Sood et al., 2007) show different work station designs based on anthropometric data. These are discussed as below;

1. For delicate work (e.g drawing) it is desirable to support the elbow to help reduce static loads in the muscles of the back. A good working height is about 50-100mm above the elbow height.
2. During manual work an operator often needs space for tools, materials and containers of various kinds and suitable heights for these are around 100-150mm below the elbow height.
3. During standing work, which involves heavy work (e.g., woodworking or heavy assembly work), the working surface needs to be 150-400mm below elbow height.

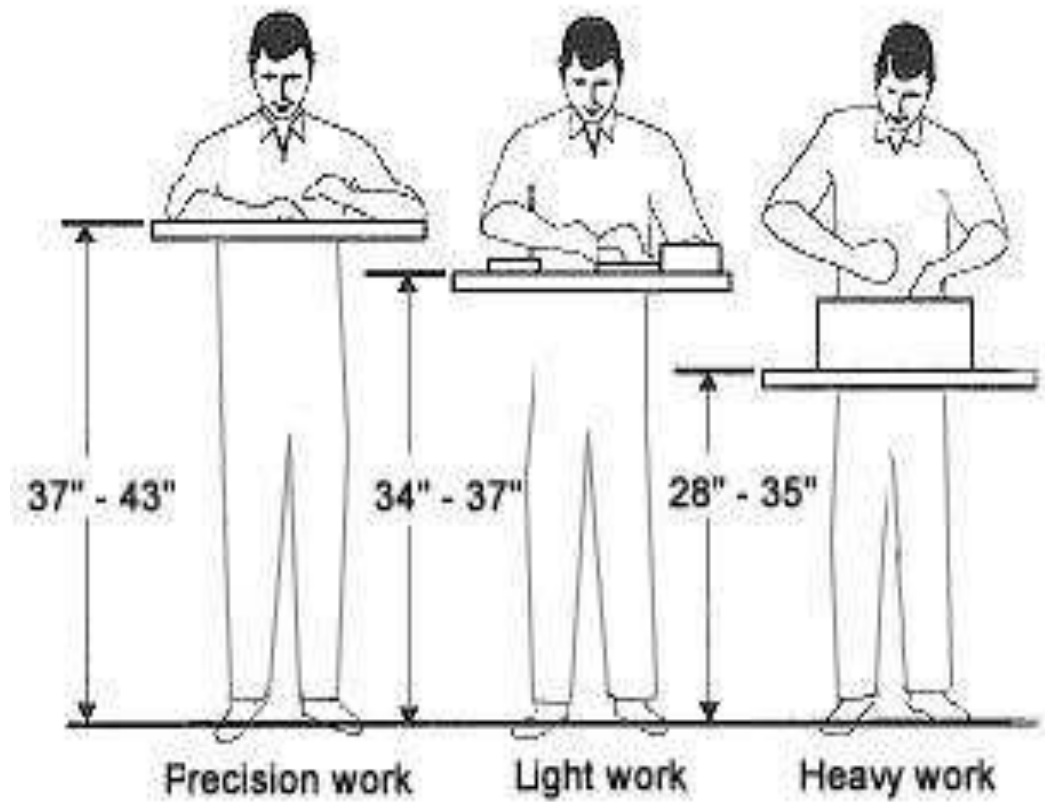

Figure 2-1: Working height for particular task (Kroemer and Grnadjean, 1997)

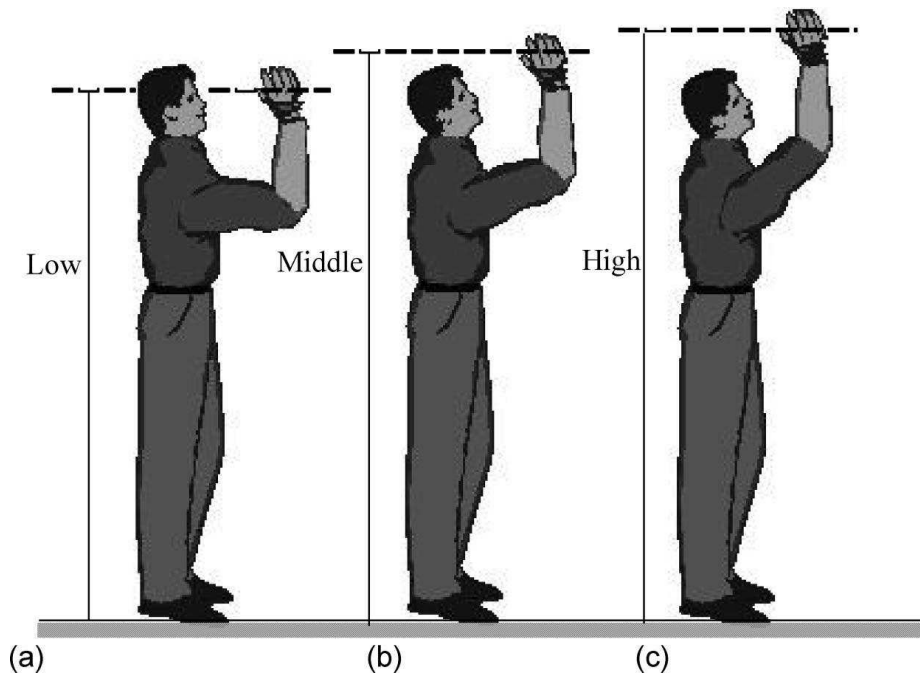

Figure 2-2: Working height for tasks at above shoulder height (Sood et al., 2007)

2.3.3 Repetitive tasks

Current trends suggest that the number of occupations characterised by long lasting, low level loads and performing repetitive operations (e.g. short cycle assembly work or office work) has been increasing (Mathiassen, 2006). Upper limb, neck and shoulders are the areas of the body which are more exposed to repetitive motion disorders. Repetitive exertion of muscles for a long duration has been reported as one of the most important risk factors in the development of musculoskeletal disorders (Larsson et al., 2007; Van Rin et al., 2001).

During the performance of tasks with highly repetitive movements, contraction of muscles occurs more quickly without sufficient recovery time. These situations will impose greater stress on muscles and tendons and may lead to damage. Smyth and Haslam (1995) considered that that if a cycle time is less than 30 seconds, or if more than 50% of the cycle time is spent in the same fundamental position/action, the condition is unacceptable.

Cyclical use of the same tissues either as a repeated movement or continuous muscular effort without movements could be defined as task repetitiveness. Repetitiveness could be accounted as a risk factor related to WRULDs (Hagberg et, al 1995). Industrial workers are more susceptible to WRULDs when work involves highly repetitive movement of hands and wrists (Marras, 1993).

The breaking up of tasks into small elements could be considered as a major cause of such repetitive tasks in industry. The adverse effects of such tasks have been considered from different points of view. Physicians believe monotonous and repetitive tasks may lead to atrophy of mental and physical powers. Increasing boredom, risk of errors and accidents may also be seen in

repetitive tasks. Social scientists believe that persons cannot show all their potentialities when performing repetitive tasks (Grandjean and Kroemer, 1997).

2.3.4 Fatigue

Fatigue refers to decreased capacity of an individual to continue effortful physical or mental work at the same rate as before. Performance of any work entails some effort, which may lead to fatigue. Fatigue is not only a normal psychological process but also reversible with rest. Fatigue can cause discomfort, especially when rest and recovery time is inadequate (Pheasant, 1995).

It is recommended that fatigue be investigated in two separate forms: muscular fatigue and general fatigue (Kroemer and Grandjean, 1997). General fatigue refers to general sensation of weariness in which there is a reduced desire to do physical or mental effort. Subjective feelings related to fatigue can be measured by rating scales such as Rating of Perceived Discomfort (McAttamney, 1994). However, research on general fatigue using perceived rating scales is very limited, particularly in the case of pacing conditions.

From a physiological point of view, muscle fatigue refers to reduced performance of a muscle after exposure to physical load. Muscle power and reaction time in fatigued muscles are lower than in fresh muscle. Muscle tension is one of the likely causes of WRULDs that may be created by repetitive movements, insufficient rest time and long duration static work posture. Keyboard operating is a particular example with a combination of dynamic and static effort. The hand and fingers do dynamic work, while muscles in the shoulders, neck and back perform static work to maintain the hands in certain position over the keyboard (Ahsberg et al., 1996). Pan and Schleifer (1996) showed that there was a positive relationship between

general fatigue and musculoskeletal discomfort during a day working at a data entry task.

Much research has been carried out on muscular fatigue using electromyography. For example, Baidya and Stevenson (1988) studied the effects of rest breaks on a local muscle fatigue during repetitive tasks. The results supported the advice that short rest breaks are preferable to the less frequent and longer breaks. Conceptually, physical demand is demand within a task that requires muscle work with the participation of each of the following systems: musculoskeletal, cardiorespiratory and nervous (Louhevaara and Kilbom, 2005). Physical workload in the current thesis refers to the demands associated with tasks that require physical work from the operators, thereby utilizing the musculoskeletal system, which mainly involve arm postures at different levels.

Most research studies have focused on the impact of operator performance (physical capacity), muscle activities, back injuries, and fatigue (Sluiter, 2006). For example, in lifting tasks numerous studies have reported that increasing the size of an object or the number of lifts per minute lead to fatigue and back disorders (Mirka et al., 1994), so exceeding the upper level of physical capacity for each individual leads to fatigue. It has been reported that increasing the levels of physical activity increases fatigue and pressure on the hand and leg muscles, in particular. In the long term, this leads to poor performance (Mirka et al., 1994). Physical workload can affect performance by influencing the muscular activity of the operator (Laursen et al., 2002). Sood et al., (2007) conducted research on measuring the rating of perceived discomfort (RPD) for overhead task in assembly operations at three working heights, in order to facilitate improved guidelines and to identify potential non-linear effects of overhead work height. They found detrimental fatigue and performance effects at extremes in reach during overhead work. Besides,

awkward postures at assembly operations, which are the risk factors in the development of musculoskeletal disorders and poor performance, other factors such as pacing and repetitive tasks have also the major role at assembly operation tasks. Therefore, it is necessary to understand the role of pacing and repetition in assembly operation. As pacing also has a cognitive demand, both physical and cognitive demands of pacing are presented together in section 2.4.3.

2.3.5 Summary

This section has introduced the physical characteristics of assembly and manufacturing assembly tasks. Some important factors related to physical characteristics of manufacturing assembly have been introduced here, working height and task repetitions, which will be discussed further in the rest of this thesis. Based on this literature, working at shoulder height and high pacing conditions is predicted to contribute to general fatigue, and also lead to quality errors. However, these factors need to be re-studied under current conditions of high demand for variety of products and high pacing (specifically the Takt situation).

While this covers the physical demands of assembly, this research also focuses on cognitive characteristics in assembly operations, which are further discussed in the next section.

2.4 Cognition and assembly tasks

Information processing during manual assembly involves cognitive functions from perception, attention and memory to action planning and execution (Laundau et al., 2001). The assembly task itself can be divided into a commissioning task and a joining task. Both of these two subtasks include the cognitive functions from perception to action execution, which are assumed to be partially sequential. Perception involves stimulus pre-processing, feature extraction and stimulus identification. In the commissioning phase, a part on the part list has to be localized, part features have to be analyzed (e.g.

small and metal), and the type (e.g. 5 mm screw) as well as the number of relevant parts for a work piece have to be identified and memorised. After localizing the relevant part in a box, the grasping action has to be prepared (e.g. precision grip with the left hand) and executed (Stork and Shubo, 2010). All of these stages may be more or less difficult depending on a number of different assembly characteristics (Richardson et al., 2006). This is discussed further below.

The main task characteristics that influence performance are workload factors, which refer to the understanding of the task (task demands) and the ability to complete the required work (capacities) (Megaw, 2005, Richardson et al. 2006). Task demand is defined by Wickens et al. (2002; 2004) as the proportion between time needed to do a certain task and the time available. From this, workload is a combination between of available resources of an operating system, task demand and workers' capabilities (Wickens et al., 2002; Wickens et al., 2004). It can also be seen that pacing is an important part of workload, as a faster pace leads to less time to complete a cycle, and can increase workload.

Cox-Fuenzalida (2007) reported that workload affects and reduces the ability of workers. Generally, an increase in the task demand level may lead to a decrease in correct responses and an increase in response time (Cox-Fuenzalida, 2007). High-task workload and task complexity are considered to be two of the most important aspects in reducing the quality of worker responses. As a result, the overload increases operator errors. Due to rapid increase in technology on the assembly line, mental workload has increased as work becomes more complex, while physical workload has decreased with more automation.

2.4.1 Assembly complexity

Cognitive performance of assembly tasks has been discussed in literature as the loop of information processes which, include the selection, attention and memory, location and execute action (Landau et al., 2001) though understanding of cognition in assembly is still limited (Shalin et al., 1996). Richardson et al. (2004) clarified that there is a lack of understanding as to what issues affect assembly performance. Richardson et al. (2004) identified seven task variables for self-assembly that were hypothesized to predict assembly complexity and systematically varied them in 16 assemblies. Participants made judgments based on the assembly instructions, and viewing time was recorded. There was a clear relationship between the task variables and the time taken to view the instructions (Richardson 2004; 2006). However, it is unclear that the task characteristics identified by Richardson (2004) may affect the assembly complexity of manufacturing assembly, which requires potential training and is highly repetitive.

In a study carried out in Swedish manufacturing industry, 64 employees with lengthy experience in design and manufacturing engineering were interviewed (Falck and Rosenqvist, 2012). The interview questions were related to assembly ergonomics, complexity and assembly quality. The results indicated that, in addition to ergonomics conditions, the degree of complexity in manual assembly work was of great importance for the outcome of assembly quality, and complex assembly tasks were said to result in more assembly failures than non-complex tasks.

2.4.2 Mental Workload and assembly

Any work load comes from the task which individuals carry out. Work performance usually entails both physical and mental load. Mental workload includes different tasks: decision-making, monitoring, perception, and calculation (Perry et al., 2008). The increasing level of automation in most manufacturing operating systems has placed more emphasis on the mental

workload (MWL) of operators (Megaw, 2005; Neerincx et al., 1996) though it is essential to note that there are considerable differences between the opinions of ergonomics researchers about the definition of mental workload for humans in the workplace (Xie and Salvendy, 2000; Hwang et al., 2008).

Neerincx and Griffioen (1996) suggest that changes in the state of workers may impact their mental capacities and influence task performance. If the mental workload is increased too much, the level of performance decreases due to high arousal level (Wickens and Hollands, 2000). However, Hwang et al. (2008) found that the correlation between mental demand and performance is not a curved line. Some direct factors may impact the level of arousal, such as environmental factors (noise, vibration, and lighting) and personal problems (Xie and Salvendy, 2000). Also, mental workload is not only influenced by task demand, but is also affected by operator factors (e.g., experience and skill) (Xie and Salvendy, 2000).

Astin and Nussbaum (2002) used subjective measures (Borg CR-10, NASA TLX) to record changes in perceived workload during varying levels of physical and mental demands. They found no effect of physical demand on subjective mental workload assessment and also no effect of mental demand on subjective physical workload assessment. However, they found high correlation between subjective mental workload assessment and mental performance ($r = -0.8$ and $r = -0.9$). It is therefore necessary to determine the interaction between physical and cognitive demands on aspects such as quality of performance and subjective assessments. The following section discusses cognitive workload and performance in more detail.

2.4.3 Summary

This section discussed the work load, mental workload and cognitive characteristics, which have been shown to have relationship with assembly complexity. The important factors were the cognitive demands of assembly (e.g, attention, memory, diagrammatic instruction), which may affect performance and quality in assembly line operations. It may also be interesting to analyse the relationship of cognitive task characteristics (Richardson, 2006) with assembly complexity in manufacturing assembly. The next section discusses, pacing, an important source of physical and cognitive workload in assembly

2.5 Pacing

Generally pacing is defined as the flow of work. Pacing is categorised as manual pacing and machine pacing. Manual pacing is the operator's time performing a particular task, whereas, machine pacing is the time of the flow of work determined by machines, such as the speed of a moving assembly line.

The early formal ergonomics research on repetitive work focused on issues associated with the perceptual demands, fluctuations in, and variability of, productivity and provision of 'pauses' or 'breaks' (e.g. Murrell 1962, 1965). More recently, performance time in industrial work has been considered as a key issue for musculoskeletal health and manufacturing (Wells, et al. 2007).

While time is a common interest for both ergonomists and production engineers there is sometimes disagreement as to how time should be allocated to best support task operation. For example, production engineers seek to trim production system or minimise process variances but this may have negative ergonomic consequences for operators (Wells et al. 2007). It has also been recognised that increase in variability in service times (e.g. time

required to complete work station task) decreases assembly line efficiency (Wild 1972). Therefore, more emphasis by production engineers is given on time spent working and to minimise variability in order to maximise throughput.

In lean manufacturing pacing is determined by the Takt time. Takt time is defined as the maximum time allowed for producing a product in order to meet the customer demands. It can therefore vary with the level of the company's order book. Within the assembly line, everything in the production cell operation is based on Takt time (Womack et al. 2007).

The next section discusses the effects of pacing on physical and cognitive performance in order to develop the research question relating to how pacing could have interactive effects due to physical and cognitive demands.

2.5.1 Effects of pacing/ Takt on physical and cognitive performance

Work pace, especially when pace is controlled by a machine, affects the worker's well-being and physical health. A higher degree of stress response has been reported when workers were exposed to paced-machine jobs compared to self-paced jobs (McActamney, 1994, Herberg, et al 1995). Dempsey et al. (2010) recently reviewed 31 studies related to the influence of piecework on health and safety. These studies covered numerous industries, utilised varied study designs and studied outcomes including pain, discomfort, work pace, break behaviour, medicine taking and recorded injuries. The authors concluded that although the literature is still sparse and fragmented, the finding that 27 of 31 studies examined showed negative health and safety consequences provides support for the hypothesis that piecework has, indeed, negative effects.

Various risk factors, for example, long working hours and high work pace, are considered to develop musculoskeletal disorders in upper extremities (Trinkoff et al. 2006; Dempsey et al. 2010). Work pace in cyclic operations is inherent to the frequent and repetitive movements (Anderson et al., 2003) and is therefore claimed to be risk factor of developing musculoskeletal disorders (Dempsey et al. 2010). Few studies have shown that higher work pace is associated with higher levels of shoulder muscle activity, signs of muscle fatigue and increase in perceived discomfort. Due to shorter cycle times and higher movement speed, which are a result of high work pace, fatigue could be expected to increase more in higher work pace (HWP) as compared to low work pace (LWP). However, studies have shown the same responses in both conditions. On the contrary, some studies surprisingly found perceived fatigue to have increased during low pacing (Escorpizo and Moore, 2007; Bosch, et al. 2011). There is also confusion in determining whether fatigue is directly related to work pace. Some studies found that fatigue was not directly related to work pace, whereas others have shown this link (Mathiassen and Winkel 1996; Dempsey et al. 2010).

Previous research on work pace has mainly discussed the effects of pacing on physical performance. However, with the latest technological developments, more complex and dynamic systems have been created that put more emphasis on human information processing requirements to use their abilities effectively. While there is research on the effects of pacing on physical performance, research is however scarce on the effects of work pace on cognitive performance especially during assembly operations. In case studies, Lewchuk and Robertson (1997; 2001) and Dempsey et al (2006), while analysing lean manufacturing tools such as Takt time, found that workers in lean manufacturing plants were over 25% more likely to report heavier workload, enjoyed less autonomy, increase in tension and being tired after work. Studies have also investigated objective measures related to

performance, including that higher speed will lead to lower accuracy on the target (Dempsey et al. 2010; Escorpizo and Moore, 2007; Bosch et al. 2011).

2.5.2 Summary

Considering the above findings from the literature, there is a need to study the effects work pace on physical and cognitive performance especially during simultaneous performance of physically and cognitively demanding tasks in assembly operations. The next section presents some of the research that shows an interaction between physical and cognitive demands that may be relevant to assembly, and points to the main research questions for this thesis.

2.6 Physical and Mental Workload Interaction

This section discusses the interaction between physical and cognitive demands and their effects on physical and cognitive performance respectively.

As we have seen so far, assembly operations place both physical and mental demands on operators. Like assembly lines, many jobs require physical effort through lifting, awkward postures and carrying items and mental effort which involves attention, monitoring and perception (DiDomenico and Nussbaum, 2008; Perry et al., 2008; Abdul Rehman Bahsal, 2012). Also, rather than just physical exertion, some jobs may place substantial demands on workers' mental capacity, such as emergency-room medical groups, workers in manufacturing systems, and soldiers in combat operations (Perry et al. 2008).

Researchers have focused on the impacts of physical and mental demands on individual performance separately. It has been observed that due to current developments in technologies and increased demands of customers, mental workload has increased more than physical workload in many jobs. Previous

studies, on the effects of physical and cognitive demands on the performance, have shown different findings.

Reviews of the literature on the effects of physical workload on cognitive tasks (Mozrall and Drury, 1996) and current information processing (Tomprowski and Ellis, 1986; Tomporowski, 2003) found contradictory findings for most of the studies due to the experimental techniques and lack of detailed structure. However, most studies have focused on physical workload capacity. There are very few studies that have specifically tested the interaction between physical and cognitive demands though some recent studies (DiDomenico and Nussbaum, 2008, DiDomenico and Nussbaum, 2011, Basahel et al., 2010, Perry et al., 2008) have subsequently indicated that interaction between physical and cognitive demands is possible.

The main findings of these studies were;

- Perceived mental demand is increased by introducing physical demand
- Number of responses decreased with the increased physical demands
- There are effects of combination of physical and cognitive demands on human performance in the pedalling and arithmetic task
- Physical demanding conditions resulted in lower situation awareness

The study conducted by DiDomenico and Nussbaum (2008) involved carrying loads of different weights while doing arithmetic tasks at low, medium and high level. The study conducted by Basahel (2010) was based on performing pedalling task on bicycle while doing arithmetic task. The study conducted by Perry et al. (2008) was based on different physical activities on a tread mill for short duration while performing the cognitive task of complex decision

making. In addition, physical activity has been shown to have an impact on cognitive functions (Fredericks et al. 2005).

However, some researchers have found that physical workload has no impact on various mental tasks. For example, Perry et al. (2008) investigated the impact of standing, walking and jogging on visual loading simulation tasks. It was found that while there were subjective differences due to workload, and differences in situation awareness, there was no significant impact on time and percentage of errors made. They said that the impact of physical efforts on this task were not clear, maybe because the mental task used in this experiment is highly complicated and not suitable for causing performance to be responsive to physical demand. Similarly, DiDomenico and Nussbaum (2011) examined different physical activities (i.e., physical efforts, frequency of movements, and force exertion levels) on cognitive information process and found that the physical effort and frequency of movement significantly affected arithmetic performance, but the force exertion level (i.e., physical lifting workload) did not. Also, many of the studies examined the impact of physical exercise on cognitive tasks after exercise sessions (not simultaneously with exercise) to evaluate fatigue effects (Tomprowski 2003). Therefore, it becomes important to clearly understand the impact of different levels of physical workload on cognitive task performance and the impact of different levels of cognitive load on physical task performance.

2.7 Theoretical explanations of interactions

After presenting physical factors (for example design guidelines for assembly, assembly operation, working height and posture) and cognitive load (for example memory, attention, task complexity), as well as pacing, this chapter then moved to the issue of physical and mental workload interactions and the effect on performance. The following final section of literature review discusses theoretical models that may explain how physical and cognitive characteristics, as perceived through different variables, may interact. First, a

possible physical model, Armstrong's model of WRULDs (Armstrong et al, 1993), is presented, followed by a cognitive model, the Multiple Resource Model (Wickens, 2002)..

2.7.1 Armstrong Model of WRULDs

Armstrong et al. (1993) found that some occupations are more at risk of WRULDs than others. Industrial operators exposed to high force and high repetition have more risk than those who are not exposed to those factors. This research led to the development of a conceptual model for work related neck and upper-limb musculoskeletal disorders, as shown in figure 2-3

The dose-capacity model suggests that task requirements combine with external factors, such as the work environment, hand tool design characteristics and work organisation to produce an internal dose which then could disturb the internal state of the individual. The individual may experience a number of responses such as changes in metabolite levels, temperature and shape of tissue. These responses usually occur in three different ways: mechanical (tissue deformation); physiological (metabolite production); and psychological (psychosocial response). Capacity refers to the ability of individual either physically or psychologically to resist destabilisation caused by the various doses. However, capacity changes over time as a result of responses (e.g. fatigue or muscular pain). This might be strength or physical ability.

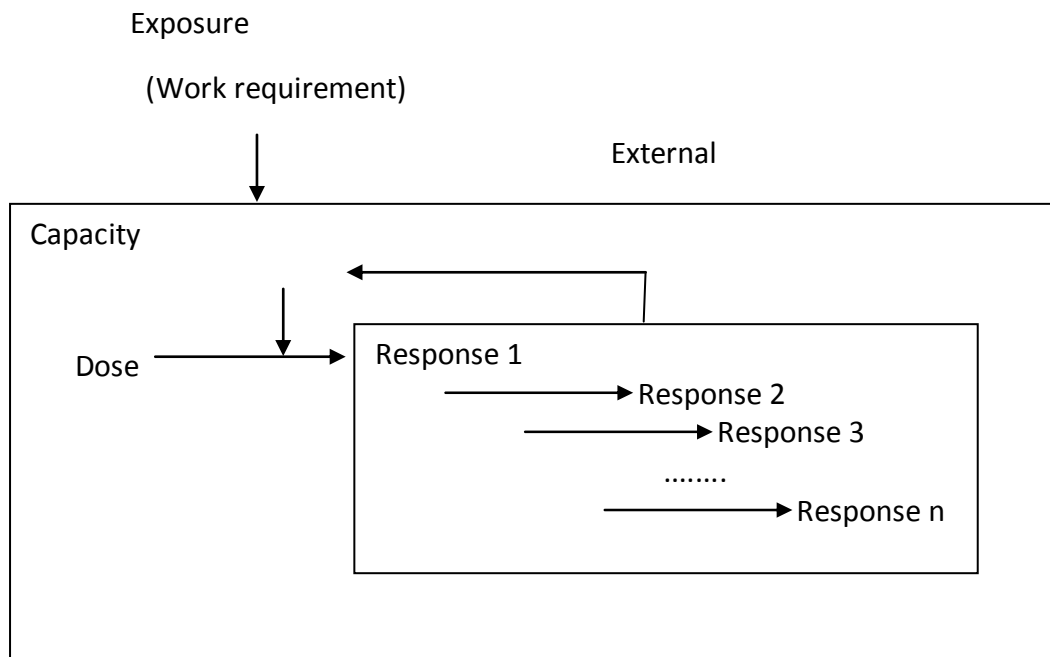

Figure 2-3: The model for development of WRULDs proposed by Armstrong et al (1993)

2.7.1.1 Relevance to interactions in assembly tasks

Assembly line operators often need to work in conditions requiring high repetitive movement of hands, arms and fingers with high precision demands and awkward postures. The other characteristics of assembly tasks are machine pacing, monotony, mental demands and short work cycles (Eklund, 1996). These characteristics show that assembly operations include simultaneous performance of both physical and cognitive demands as external factors.

Armstrong et al's dose-capacity model in this regard could be an aid to understand the combined effects of physical and cognitive demands through cascading variables as discussed above. One example of how the dose-

capacity model may explain workload in assembly is pacing, as illustrated below:

External factors: Pacing is a task time or service time to complete a task. In assembly, this might come from the Takt system or machine-paced work.

Dose: Increased pacing could produce a dose that can cause disturbance and may affect the physical performance. This might be as physical demands due to increased frequency of work in high pacing conditions (Dempsey, et al., 2010).

Responses: Pacing may lead to physical fatigue - a physical response- but may also lead to greater error - a psychological response (Dempsey et al., 2010; Bosch et al., 2011).

Capacity: Capacity decreases over time because of fatigue due to pacing (Bosch et al., 2011).

The main aim of the research in this thesis is to determine whether there is a possible interaction between physical and cognitive demands and its effects on performance during assembly operations. Armstrong et al's dose-capacity model as mentioned above with respect to assembly operations can explain the link between physical demand on physical performance (e.g. fatigue) as well as effects of physical demands on psychological performance (e.g. error due to pacing). However, the dose-capacity model is limited. First, Armstrong et al. (1993) pointed out that there is a relationship between biomechanical and psychological factors, but the authors also said that "quantitative relationships, however, need to be described in future research" (p. 81). The model discusses psychological responses as being psychosocial (e.g. stress). However, Perry et al (2008) showed that psychological responses may also apply to cognitive performance, like situation awareness. Second, the

relationship model focuses on physical factors (tools, environment etc) as an exposure variable, but cognitive demand might act as a dose that leads to physical response. Richardson et al (2004; 2006) identified the task variables that were hypothesised to predict assembly complexity (e.g. components and fastenings). These variables might fit in Armstrong's dose-capacity model. Assembly complexity and instructions may be taken as the external factors that produce the dose in the form of nature of assembly complexity and the type of instructions. Furthermore, based on the relationship between capacity (task characteristics and ability) and dose, the physical and psychological response might be fatigue and thinking time. It is therefore necessary to look at how cognitive demands affect performance. Therefore, it is useful to look at Multiple Resource Models in order to understand how different types of cognitive task might affect performance.

2.7.2 Single and Multiple Resource Models (MRM)

While the dose-capacity model can help in understanding the relationship between physical demands and response, there needs to be a better way to understand cognitive demands and cognitive response, if we are to understand interactions of physical and cognitive factors in assembly. Various theories have been developed that describe information processing. These theories show the value of memory in performing cognitive tasks and the limitations of working memory capacity.

The classic model of single resources was developed by Kahneman (1973). The single-resource theory assumes that individuals have limited cognitive capacity. The capacity model assumes that exceeding capacity limits, by performing concurrent tasks, leads to interference, and a decline in performance. According to the Kahneman model of attention, while performing concurrent tasks, individuals can manage and control the attentional process through a strategy for resource allocation. So the main

factor of a cognitive capacity theory is that performance suffers when there is no balance between the required demands of tasks and attention resources.

The Multiple Resources Model (MRM) was developed after weaknesses were found in single resource theory, especially related to the interpretation of attentional resources in a dual task approach (Wickens, 2002). It was proposed in MRM that dual-task interference will increase only when both tasks require the same attention resources. On the other hand, task performance can be preserved if the tasks use different resources.

Attention is related to the dual task performance. Task performance will be maintained provided attention is divided in a way so that the two tasks require different resources (visual or auditory). However, performance may suffer if the two tasks require similar attentional resources (Wickens, 2002). This is the case when one of the two tasks is more difficult than the other task (Wickens, 2008).

Wickens (2002, 2008) mentions that there are four dimensions of the multiple attentional resources model (shown in figure 2-4). These four dimensions are discussed as follows;

Processing stage leads to the perception, working memory, and response. This is the processing dimension that is responsible for resource selection, central executive function (working memory), and response function. The main function of the processing stage is to predict the interference between the resource workload of mental tasks and perceptual activity in the working memory storage function and data conversion function (Wickens, 1988).

Processing codes involve two types of resources: spatial and verbal. This dimension increases the efficiency of performance (response dimension) in dual-task performance since it makes a distinction between verbal and spatial resources and deals with the information as a separate resource, depending upon its type.

Input modality: auditory or visual. Wickens (2002) added a new dimension to the MRM model within the visual channel, to reflect the distinction between focal and ambient vision as separate resources and with separate capacities.

Response: This dimension relates to the processing stage dimension. The information in the stage dimension is separate and is dependent upon the selection attention and execution of responses, which includes vocal and manual responses.

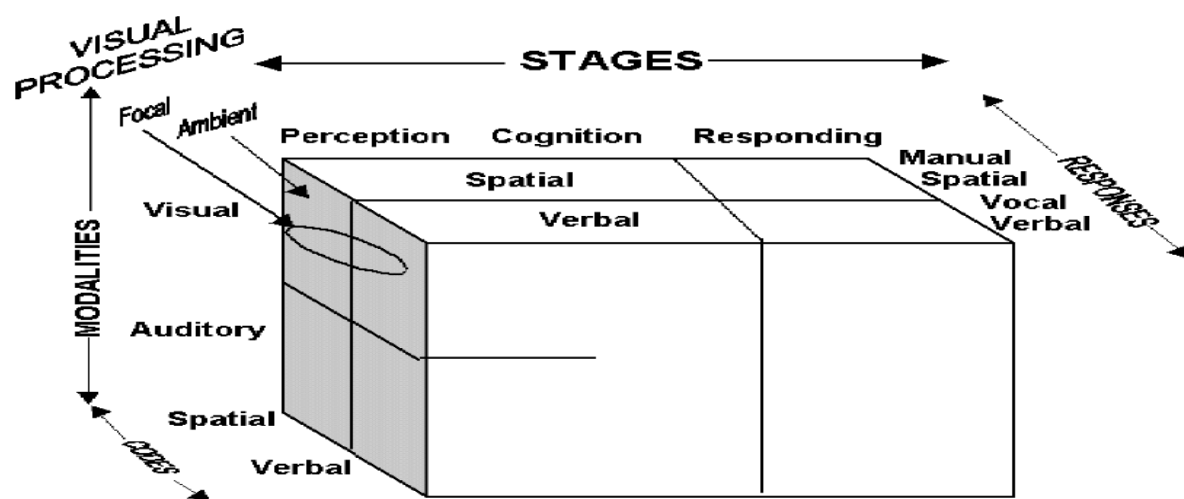

Figure 2-4: Multiple resources model by Wickens, 2002

Considering the above dimensions of the multiple resource model (MRM), the model seems to suggest that processing of information flows from sensory input to the processing stage through particular channels depends upon the type of information and type of task – specifically whether the task is mainly verbal or spatial (Wickens, 1984). The performance of an individual depends upon his/ her capacity limit, specifically when interacting with different task

at the same time (time-shared) (Wickens, 2002). For instance, studies have examined the impact of workload difficulty on attention resource capacity using primary and secondary tasks. It was found that increasing difficulty in the primary task leads to decreased secondary task performance, since resources have a limited capacity (Wickens, 2008). Therefore, if the amount of resources required to complete a task exceeds the upper limit of available resources in the same modality, performance will suffer.

2.7.2.1 Relevance to interaction in Assembly

The main focus of MRM is the interpretation of attentional resources in a dual task approach. Performance may suffer if the two tasks require same attention resources (intra-modal). On the other hand, performance may be maintained if the two tasks require different resources (cross-modal) (Wickens, 2002, 2008).

Assembly may have multiple competing cognitive demands, for example, task complexity, instructions and memory. The MRM model might be a useful approach to understand how different mental tasks related to assembly are being perceived through different dimensions of MRM, and how assembly performance is affected depending upon resource capacity.

The MRM however, is limited when it comes to investigating the effects of physical demands on resources. Assembly operators use their cognitive functions such as perception, visual, auditory and monitoring resources. Physical activities, in addition, are required, such as picking parts, tools, fastening the parts and so on. There is some evidence that complex motor control tasks might lead to a cognitive workload (Dotov et al., 2011) and this might be because it requires spatial resources. Operators also perform at different levels of physical workload, especially in heavy assembly products and traditional assembly factories (i.e., the assembly task depends on manual

work rather than automation). It is less clear how physical effort might lead to cognitive load as found in Perry et al. (2008).

2.7.3 Summary

Theories of workload suggest that there may be a relationship between physical and cognitive demands and how they impact on operator performance. Two main theories have been considered:

Armstrong et al. (1993) proposed the dose-capacity model in which the perception of physical and cognitive demands (visual, auditory and or spatial) and its effects on objective and subjective performance during assembly operation, lead the operator to perceive the physical and cognitive demands concurrently. However, the model does not state how cognitive and physical factors combine. Therefore, Armstrong's model offers an understanding of how **physical and cognitive external factors in assembly may lead to dose and response** that can be tested in the laboratory.

The Multiple Resources Model (MRM) (Wickens, 2002) suggests **that the combination of similar task demands may lead to workload**, but this leaves a gap in the literature to investigate how the demands of assembly are perceived through different channels and what effects they have on performance and attention resources.

2.8 Research questions

This literature review has provided a background to understand the nature of assembly tasks along with the physical characteristics and cognition involved in the assembly of self-assembly objects and manufacturing assembly.

Physiology and anatomy of posture at the task has been discussed. The literature then moved to the major issue in the thesis that clarified the interaction between physical and cognitive demands during the simultaneous performance at the assembly.

Previous studies have not adequately accounted for the impact of physical activities on cognitive tasks and mental functions. In most studies, researchers investigated the effects of various levels of physical exercise on one level of mental workload (Mozrall and Drury, 1996). Measurements of general workload for tasks that require both physical and mental input are rare.

Previous authors have investigated the influence of physical and/or mental workload on individual performance independently. Some researchers have found that physical demands impact cognitive functions (e.g., Perry et al., 2008). However, the relationship is not clear. Theoretical models proposed by Armstrong et al., (1993), and Wickens (2002) can help to explain this relationship.

Literature has indicated a relationship between physical and cognitive demands, however there is no simulated study conducted on assembly tasks which involving concurrent performance of both physical and cognitive demands. As discussed earlier in the chapter, assembly may involve concurrent physical and cognitive demands therefore it is important to understand if any relation exists. This is also important considering the current trends of increased Takt time and product variety which may increase operator stress. Keeping into considering the facts related to impact of physical and cognitive workload on the performance, it is necessary to bridge the gap by understanding the interactive effects of physical and cognitive demands on the quality of performance at the assembly line operation.

The research questions for this thesis are therefore:-

- What are the physical and cognitive issues that might arise in paced assembly lines?

- How do different levels of Takt time affect the working conditions during simultaneous performance of physical and cognitive demanding tasks?
- What interactions might occur between physical and cognitive demands for assembly?
- How could different theories for the interaction between physical and cognitive demands be examined?

In order to further explore the relationship between physical and cognitive demands, field studies (observation and interviews) were carried out to understand the current status of manufacturing tasks, which consist of simultaneous performance of physical and cognitive demands as discussed in Chapter 3. This would address research question 1 and help with the design of a simulated assembly task to address the other questions.

3 Familiarisation and understanding of assembly tasks

3.1 Introduction

The literature review, in chapter 2, aimed to understand the impact of physical or cognitive workload involved in assembly tasks. The literature review identified a need to further explore this in order to better understand the separate and combined impact of physical and cognitive workload on assembly task performance. The Armstrong dose-capacity model (Armstrong et al., 1993), and Wicken's multi-resource model (Wickens, 2002 and 2008) were presented as potential models that may help us to understand the factors affecting the interacting physical and cognitive factors. The focus of this PhD research therefore was to examine:

1. The effects of physical exposure (e.g. arm posture) during assembly operation under different pacing levels / Takt time on task performance
2. The effects of cognitive load (e.g. memory) during the assembly operation under different pacing levels / Takt time on task performance
3. Determine whether there is an interaction between physical and cognitive characteristics during the simultaneous performance of physical and cognitive demanding tasks.

In order to understand how cognitive and physical workloads occur in real assembly operations, a number of field visits and observations were conducted at manufacturing companies. These visits also aimed to help design realistic laboratory tasks for the study of the interaction of physical and cognitive loads. The following chapter presents an investigation into the physical and cognitive characteristics involved during assembly line operations observed in four different companies. Data collection included six interviews with subject matter experts conducted during visits to different industries, and around 25 hours of observations on the assembly operations. Tasks related to the simultaneous performance of physical demands (e.g.

work height, repetition) and cognitive demands (e.g. instruction, complexity, memory) under pacing levels (Takt time) in moving assembly line and stationary assembly are discussed. Finally, issues related to fixed pacing / Takt time under simultaneous performance of physical and cognitive demands are discussed as a basis for conducting the lab studies, which are then presented in Chapters 4, 5, 6 and 7.

3.2 Background

Previous case studies, laboratory studies and surveys have shown the positive relationship between the physical characteristics involved in assembly tasks, including tasks associated with repetitive movements or uncomfortable posture, and musculoskeletal disorders (Haslegrave, 1990; Delbridge et al., 2000, Escorpizo and Moore, 2007; Bosch et al., 2011). Similarly, studies have also shown the impacts of mental workload on the quality of performance (Wickens and Hollands, 2000; Hwang et al., 2008). Recent literature has also shown a potential relationship between physical and cognitive demands (DiDomenico and Nussbaum, 2008, DiDomenico and Nussbaum, 2011, Basahel et al., 2010, Perry et al., 2008), with detailed description about these studies discussed in chapter 2.

Due to increased customer demands for a high variety of products, traditional mass production in which an assembly line is used for one product type or only (commonly known as Single Model Assembly Line (SMAL)) has been replaced by lean manufacturing where different types of products being assembled, known as Mixed Model Assembly Line (MMAL). While MMAL may satisfy the customer demands by producing the products Just in Time (Hwang and Katayama, 2009), there is a risk that changes to the workstation tasks at the assembly line including high variability and reduced workstation time / Takt time, have increased the physical and mental workload for the assembly line workers (Zhu et al., 2008).

In general, the academic literature has usually discussed separately the impacts of physical and cognitive demands, though a few (DiDomenico and Nussbaum, 2008, DiDomenico and Nussbaum, 2011, Basahel et al., 2010, Perry et al., 2008) indicate the need to investigate the interaction between physical and cognitive demands in an experimental setting.

Therefore, in order to develop the link between previous researches, presented in Chapter 2, and planning for the experimental study to be conducted in this PhD research, industry visits were carried out to identify issues related to simultaneous performance of physical and cognitive demands in typical assembly tasks in manufacturing industries.

Overall, the aim was to understand the characteristics that might influence real assembly work, so that pacing, and physical and cognitive demand could be simulated in realistic manner in a laboratory task. Specific questions included

- Types of tasks: what types of assembly line are used (e.g. moving assembly line, stationary assembly, and precision tasks)
- Variability of tasks: how assembly tasks changed depending on the type of product (automobile, aero engine, crushers).
- Takt time: did workstation tasks in a moving assembly line use fixed pacing/ Takt time, and what how did that change the task
- Postures: what were the characteristics of tasks related to work height, or different body postures during the task performance
- Cognitive demand: what were the task characteristics that involve cognitive demand, including following instructions, task complexity, precision, or memory

3.3 Industry visits

Data was collected from four industrial companies. Three companies were visited in the UK: Company A, B and C. These industries were implementing some of the techniques of lean manufacturing, which might influence physical or cognitive load. However, there was variation between the companies in their assembly operations (for example variation in pacing / Takt time, moving assembly and stationary assembly). Therefore, the selection of industries in the UK provided the wide range of understanding of the tasks that might comprise simultaneous performance of physical and cognitive demands.

An additional company was visited in Finland: Company D, a leading supplier of equipment, services and process solutions to the mineral industry. Company D carried out assembly of large machinery (e.g. crushers, lokotracks) in a stationary assembly. The company had reports of manual handling problems related to task complexity, material handling and posture and were planning to alleviate these through changes to their processes. The visit was a part of the ManuVAR (Manual support system throughout complete product life cycle by exploiting virtual and augmented reality) EU funded project of which the Human Factors Research Group (HFRG) at the University of Nottingham were partners (<http://www.manuvar.eu/>). The objective of ManuVAR was to develop an innovative technology platform and a framework to support high value manual work throughout the product lifecycle. HFRG were involved in consideration of issues related to ergonomics, safety, work assistance, and training of a variety of personnel in the product life cycle including designers, factory workers, operators, maintenance personnel, and end-users. ManuVAR provided the author with the opportunity to conduct site visits and observations at the plant in Finland.

Methodologies used in the data collection included observation and both structured and unstructured interviews with subject-matter experts including

management, technical engineers and workers. The nature of visits in each of the companies was different, which gave different opportunities to see and do different things. Some of the visits were limited and did not permit photography or interviews with the operators. However, company D allowed video to be captured which allowed some further analysis of tasks after the visit.

The following sections describe the case study conducted at each company in turn, under the following sections:

- Procedure for observation
- Company and plant description
- Assembly tasks observed
 - Physical attributes of the work
 - Cognitive attributes of the work
- Summary

The findings from all of the case studies were used to define a representative assembly task that could be conducted in the laboratory for the experimental studies to be conducted in this research.

3.3.1 Plant A - Automobile assembly

3.3.1.1 Procedure

Plant A was visited twice: in 2009 and in 2010. It was not possible to obtain private access to the plant and so both visits were part of the standard, organised tours offered by the company. This meant that the author was one of a group of 10 people who were guided by a technical member of staff. Duration of the plant visit in was three hours, of which two hours was spent on the assembly line. Over two visits this provided a total of four hours of observation.

Unfortunately, due to the general nature of the visits, it was not possible to conduct interviews, survey or any video observation with assembly staff during the plant visit. However, the nature of the tour allowed informal observation and familiarisation with the process of automotive assembly, and of a number of assembly tasks. In addition, the tour guide on both occasions was a member of staff who had worked on the assembly line, and therefore answered questions from the observer regarding assembly operations.

All observations of assembly tasks and responses to interviews were recorded using paper and pencil.

3.3.1.2 Company and plant description

The plant at company A was divided into three sections through which the automobile was being processed:

- 1. Body Shop** In the body shop, different parts of car were welded into a whole body and then the body is processed to the paint shop
- 2. Paint Shop** The welded body is then moved to paint shop where the body is being processed through different stages. However, we were not allowed to visit paint shop due to high temperature in the paint shop
- 3. Assembly Shop** A painted body was processed to assembly shop, which was divided into three sections: trim, chassis and final assembly.

At the time of visits (2009 and 2010), the type of production in Plant A was built to order (customized) and most of the production was exported to the USA. The total production per week was 650 cars and the total time of production per car was around one week.

3.3.1.3 Assembly tasks

During conversation with the plant guide, it was identified that work station time (Takt time) was 3.3 min. Automation in the plant was about 70%, the remaining 30% being manual work. The plant seemed to be partly implementing lean manufacturing, with some lean manufacturing characteristics observed on assembly line operations. These included

- *Continuous flow* (smooth flow of work in process with minimal buffers between steps of manufacturing processes).
- *Visual Kanban* cards were observed at the cars containing consumable part needed by the worker at workstation.
- *Andon* lights were seen at each work station in the assembly line. Workers stop the line when they see any problem.
- *Takt time* is fundamental to lean manufacturing and is defined as the maximum time allowed for producing a product in order to meet customer demands (Schroer, 2004). Workstation/ Takt time during the visit was 3.3 minutes to produce 650 cars per week. Takt time was not demanding and operators seemed to have finished their work before time and waited for the next part to come.

3.3.1.4 Physical characteristics of assembly tasks

The operators at each workstation in the moving assembly line did not seem to lift any heavy weight that could cause high physical workload. Parts that were handled manually were typically nuts, bolts, and small components and fixings. Lifting assist devices were being used to carry and hold the heavy part (e.g. door, glass).

The parts were collected from shelves positioned a few steps away from the workstation assembly. The operator carried the part from the shelf to the workstation for assembly. While it was not possible to conduct a detailed analysis about the awkward postures during the short visits, awkward

postures such as working at arm above shoulder heights were observed during the assembly operations.

3.3.1.5 Cognitive characteristics of assembly tasks

The plant was producing three different models of the automobile. These products were being processed randomly through workstation, using a Mixed Model Assembly Line, in order to produce the product just in time. Since, the assembly of products was different depending upon the models, the operators had to be careful about the assembly of the required part for the required model. It was observed that the assembly operator needed to pick up the correct part out of many similar parts required for the particular model of the car at workstation. During observation and conversing with the guide, it was found that operators were also supposed to self check the quality of the part (e.g door rubber or sunroof glass rubber etc.) in order to accurately fit the part in to the required space.

3.3.1.6 Summary

The Plant A visit provided an opportunity to observe assembly operation tasks in a moving assembly line. Due to the short duration and general nature of the visit, it was not possible to quantify specific issues related to physical and cognitive demands. However, some of the characteristics pertinent to awkward postures, picking right part for the right product, mixed model assembly line were observed, which could impose physical and mental stresses, provided the Takt time is reduced. This might be possible in case of increased customer demands.

In addition, some of the task related simultaneous performance of physical and cognitive demands observed in the industry are discussed below

- Tasks in the plant were observed to involve awkward posture (above shoulder height), which may lead to the development of musculoskeletal disorders.
- During the visit, it was observed that the operators in the assembly line finished their tasks before the Takt time and were waiting for the next part to come. This may be beneficial for the workers to have a bit of time to rest but, in lean manufacturing terms, could be considered to be increasing 'non value adding' activities due to waiting time (Womack and Jones, 2007).
- Another observation was picking up the correct part out of many similar parts, which was the responsibility of the worker and can increase cognitive demands.
- As the part was quite similar for all automobiles, the operator had to take care of coding that described which part belonged to which car. This can lead to high responsibility and may cause errors (Xie and Salvendy, 2000).

3.3.2 Plant B – Aero-engine assembly

3.3.2.1 Procedure

The visit to plant B visit lasted around 4 hours, which included the observation of aero engine assembly and conducting of interviews related to the lean manufacturing, and physical and cognitive demands during the task performance. As with the plant A visit, data collection was informal. Notes were taken and it was possible to discuss issues and raise unstructured questions with the manager leading the visit, and staff on the assembly floor.

3.3.2.2 Company and plant Information

Plant B, an aero engine assembly plant, is one of six branches in the UK. The company is a global business providing integrated power system for use on land, at sea and in the air.

The production observed in the Plant B was the assembly of a range of jet engines across a product range. Each engine was further specified with a particular number in order to show the identification and size of the engine. At the time of the visit two engines were being assembled concurrently. The engine is divided into a number of modules which are assembled together to produce a completed engine.

3.3.2.3 Assembly task Observation

During the visit, assembly of the module where compressor rotor fans and blades are fitted was observed. Assembly operators were highly skilled and multitasking. At the time of visit, assembly time of module took around 12 hours. Due to very long assembly time, the operators seemed free to do their task any time they wanted. The assembly was performed standing and also awkward postures were observed especially during installation of the blades. Operators also followed the design and instructions to perform their complex assembly tasks of blade installation.

3.3.2.4 Physical characteristics

The type of assembly was stationary. Due to long cycle time and stationary assembly of jet engines, operators seemed to work in a standing posture. Stationary assemblies were lifted by lifting assisted devices. However the required parts, lying a few steps away from the assembly, were carried by the operators to the stationary workstation.

3.3.2.5 Cognitive characteristics

During the observation, it was noted that the operators followed the design and instruction to perform their complex assembly tasks of blade installation. It was necessary for an operator to install the right blade at the right position. Time pressure was low because of the very long Takt time, however, tolerances and quality of build meant that accuracy had to be extremely high in the construction of the assemblies. Also, each individual blade needed to be matched to the engine assembly.

3.3.2.6 Summary

The operators were highly skilled and performed their tasks quite comfortably without putting themselves into any stress. Because the time to complete the module assembly was high (in hours), therefore operators were free to do their task any time they want. During the visit high precision tasks were observed, which required mental representation to perform the task carefully and correctly.

3.3.3 Plant C – Industrial vehicle assembly

3.3.3.1 Procedure

Plant C was visited twice, in 2009 and in 2010. The duration of the first visit was 3 hours and in second visit was 2 hours. In total for the two visits, four hours were spent on the assembly plant and one hour was spent interviewing a manager of assembly operations (who also acted as visit guide) who provided information regarding the processes and assembly operations carried out in the plant. Observations and the interview were recorded using paper and pencil. Video was also provided that demonstrated different assembly processes. This allowed further analysis of assembly activity including postures.

3.3.3.2 Company and plant Information

Plant C is one of the world's top three manufacturers of construction equipment. The company employs around 7000 people on 4 continents. The products are sold in 150 countries through 1500 dealer depot locations.

The Plant C plant in the UK produces different types of mechanical diggers. The final product is manufactured and assembled through 8 different stages; cutting the steel, welding, stress oven, paint and spray, digger assembly, fitting the arm, quality test and shipping.

The current production observed during the visit was one specific type of construction vehicle and the observation was focused on the assembly and fitting of one major component of the product – mechanical digging arm - which was on the moving assembly line.

3.3.3.3 Assembly task

The plant was implementing some of the lean tools and techniques. The plant was running slow due to very low Takt time and during the visit, not all the assembly operations were being performed. The Takt time for fitting the backhoe arm was 13.5 minutes. The current Takt time was more than double the previous year, which was 6 minutes to fit the arm. It was discussed that the increased time was due to low customer demand. In connection to the increased Takt time, it was also observed that the operators were quite comfortable to perform their tasks. However, this might cause an increase in monotony or under-load.

Regarding the implementation of a just in time system, it was found that Plant C was really trying to get one process to make only what the next process needs when it is needed. The Kanban system was being used on consumable items (nuts and bolts). They were trying to link all processes – from the final customer back to raw material in a smooth flow without detours that generate the shortest lead time, highest quality, and lowest cost.

3.3.3.4 Physical characteristics

During the visit, it was observed that the operators were frequently changing their postures to perform their assembly tasks in a workstation of moving assembly line. Operators were lifting parts as well as tools (for hammers etc). It was not clearly observed how heavy the parts and tools were. One of the physically demanding tasks observed during the visit was the fitting of arm, where the operator was seen in awkward posture, which involved fitting components at shoulder height and therefore shows high exposure of upper arm. However, due to high Takt time the task was perceived to be performed

comfortably. It was unclear if this would be case if the workstation time reduces due to increase product demands.

3.3.3.5 Cognitive characteristics

Due to the slow pace, there were no major demands due to work pressure. However, during the interview it was identified that operator self check the part for quality before fixing it to the assembly. Push buttons were also seen at the workstations, which were used to stop the assembly line in case of any problem occurred.

3.3.3.6 Summary

During the visit, operators were found to perform the task in awkward postures (fitting the bakhoe arm at the above shoulder height in awkward body posture as well), and self check of the parts for the quality. These could be stressful and may develop musculoskeletal problems and quality issues in case if the workstation / Takt time is reduced. However, due to high workstation time assembly operators seemed comfortable to perform their task.

3.3.4 Plant D - Mineral equipment manufacture

3.3.4.1 Procedure

There were two data collection activities related to Plant D. The first activity was carried out in 2009. The first day involved preparation of a series of interview questions for staff for company D. These are included in the Appendix. The second day involved interviews with five members of company staff including two assembly workers, two technical staff and one senior manager. This was conducted as a group session and took around four hours. Interviews were conducted in the VTT Institute in Tampere, Finland. Data was recorded with paper and pen, along with tape recording to assist note taking.

The second visit was organised in 2010. The visit consisted of observation and interviews with the people working in industry. This was a one day visit and

last for around 6 hours to visit different sections of the assembly plant. This was observation with pen and paper notes. Also, Company D gave permission for photographs to be taken. These were reviewed after the observations.

3.3.4.2 Company and plant information

Company D is a leading global supplier of equipment, service and process solutions to industries. The industries include quarrying and aggregates production, mining and minerals processing, construction and civil engineering, and recycling and waste management.

The production was the assembly of crushers and lokotrack, which were stationary assemblies. The typical time for production of larger products was 4 weeks, with the assembly process taking about 1 week. Delivery time of larger products was about 6-8 week.

3.3.4.3 Assembly tasks observation and interviews

The visits consisted of interviews and observations. A semi-structured questionnaire was used as the basis for interviews conducted with representatives of senior management, middle management, worker and engineer/technical personnel. The observation lasted for around 6 hours, which consisted of detailed observation of different areas of assembly operations where workers were involved in manual work.

3.3.4.4 Physical characteristics

In a large stationary crusher assembly (Gyratory crusher) workers were required to carry heavy loads (15-20 kg), working in awkward posture for around 10 to 15 minutes (reported by worker), carrying a heavy gun that weighed about more than 5 Kg. This type of work requires good strength and physical capability. Women were not working in large crusher assembly.

In the engine module stationary assembly and Lokotrack line assembly the work was not very heavy as compared to large crusher assembly. Women

were observed to be working in these assemblies. However, workers were seen in awkward postures. For example, workers had to bend to assemble loads of 10-15kg for around 10 minutes. Figure 3-1 gives another example of operators working at shoulder height. Also heavy parts were carried by workers. Heavy lifting and driving the end product were the phases where care was required to prevent any injuries etc.

3.3.4.5 Cognitive characteristics

Visual control boards showed the type of machine and (target times) start and end times. Also paper work / and design diagrams were followed by the workers frequently. A basic level of manufacturing drawing reading skill is needed for everyone for understanding the assembly drawings.

According to foreman, missing parts are the most common example of distraction in the plant. Especially for a customized product and also building prototypes in productization phase, sometime workers needed to go round the whole factory to look for a missing part, which could take half a day.

In the Lokotrack line assembly, work was described and pasted on the wall at each work station of assembly line. The team of three workers (2 Mechanical and one electrician) chose their tasks themselves.

In the large crusher assembly, the whole stationary assembly needed to be completed in 5 to 7 days. Work is done by same workers till start and finish of the assembly. After completion, workers are assigned to work on different assembly. Hosing the engine module assembly required experience in order to be assembled correctly.

Loud noise was heard during the use of bolt gun. The gun was used once in an hour and continued for around couple of minutes. It was also observed that not all the workers were using hearing protective equipment. Worker also reported to have difficulty in doing work in noise without using ear protective.

3.3.4.6 Summary

The two visits at Plant D provided detailed information based on observation and interviews. Different tasks related physical and cognitive characteristics were observed and the related issues have also been highlighted. Heavy assembly tasks with longer cycles were performed that caused physical workload as can be seen in figure 3.1 and 3.2. Some of the tasks were also observed that required simultaneous performance of physically and cognitively demanding tasks (for example, the assembly of hosing, which required the operator to follow the instructions).

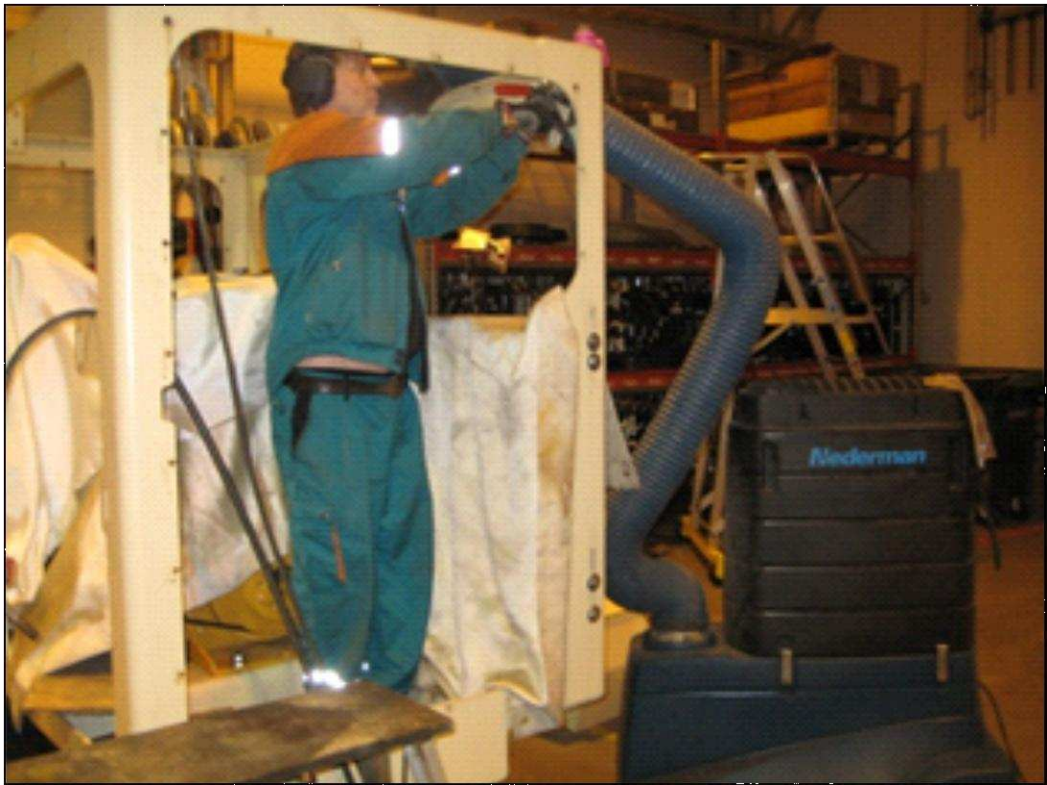

Figure 3-1: Task carried out at shoulder height

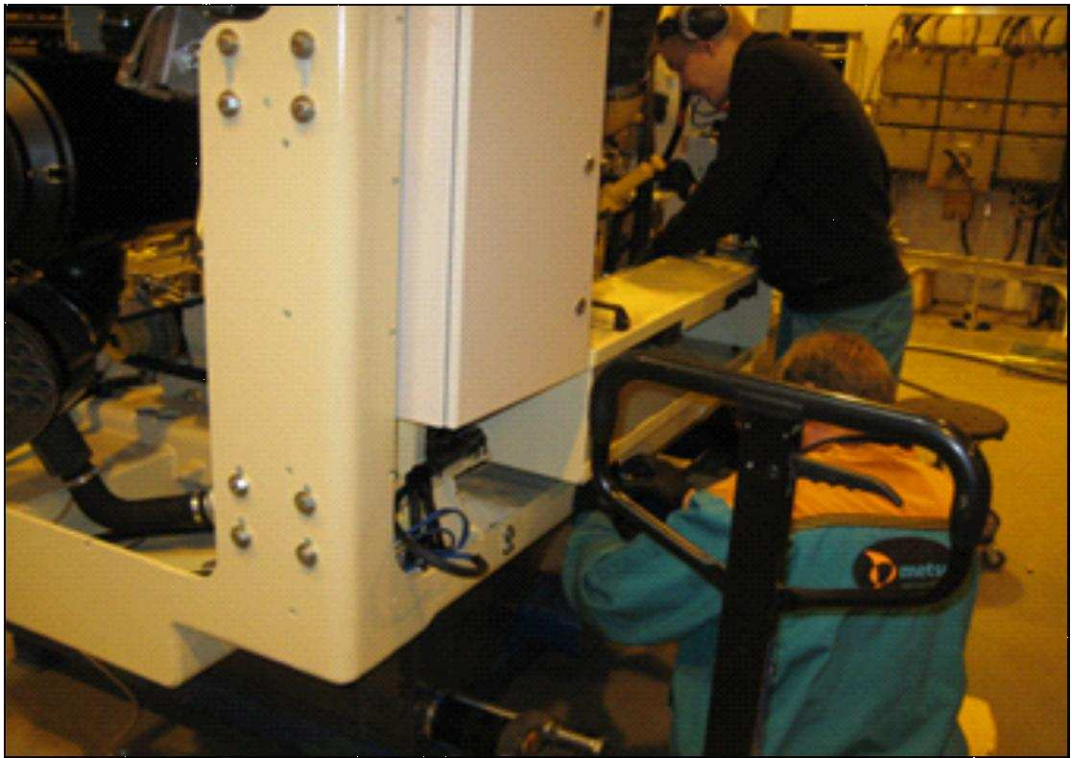

Figure 3-2: Complex task carried at stationary assembly

3.4 Discussion

Following the literature review, which introduced the relationship between physical and cognitive demands (DiDomenico and Nussbaum, 2008, DiDomenico and Nussbaum, 2011, Basahel et al., 2010, Perry et al., 2008), it was considered that it would be useful to observe real assembly tasks in industrial manufacturing in order to identify a suitable assembly task for the experimental studies to be conducted in this PhD research. The aim of industry visits was to clearly understand the physical and cognitive demands occurred during the performance of assembly tasks, especially considering the time of completion of the task, postures involved in the assembly task and understanding the complexity of the task.

During the observation, it was found that all the industries were working under fixed pacing/ Takt time. In plant A and C the production flow was moving assembly line and the Takt time of each workstation was 3.3 min and 13 minutes respectively. The Takt time also varied according to the customer demands. If the demands are high, Takt time may be low and if the demands are low, Takt time may be higher. However the assembly of Plant B and D were stationary and the completion time of the each stationary assembly was 12 hours and 5 to 7 days respectively, which was very high. While this meant there was less pacing pressure, both assemblies were much more complex requiring precision and sometimes bespoke construction for each assembly.

Regarding the physical and cognitive issues, one of the most complex tasks observed at Plant D, was fixing of hydraulic hosing in engine assembly. It was difficult to interpret the instructions to understand where cables have to be placed, even if there are drawing and pictures. This created both physical load when fixing the hosing and mental load while understanding the complexity

of the task and it was more stressful when the task was not performed in time.

During the visit in plant A, it was observed that the operators in the assembly line finished their tasks before the Takt time and were waiting for the next part to come. This may be beneficial for the workers to have a time to relax and on the other hand is a disadvantage for lean manufacturing system as non-value adding activities increases due to waiting time (Womack and Jones, 2007).

Another observation found in the plant was picking up the correct part out of many similar parts, which was the high responsibility for the worker and can increase cognitive demands. This task was observed in Plant A in which an operator was selecting and picking a related part for a particular automobile at a few steps away from automobile. The assembly line was mixed model assembly through which different models of automobile processed through workstations. Though the part was quite similar for all automobiles, the operator had to take care of the coding that described which part belonged to which car. This can lead to high responsibility and may cause errors (Xie and Salvendy, 2000).

Different factors (physical and cognitive) were observed during the assembly operations in plant A, B, C and D. These factors were material handling, awkward postures, long and short Takt time, waiting, walking, following instruction and memorising codes. Research has discussed in detail about the relationship of these factors with the increased musculoskeletal disorders, fatigue, stress and mental workload (Sood et al., 2007, Dempsey et al., 2010; Wilkinson and Haslegrave, 1993). However, as discussed in chapter 1 and 2 very little research has been conducted to determine the relationship

between physical and cognitive demands. Therefore, in this thesis, emphasis is given to the factors that occur simultaneously while performing the assembly operations. In order to define a laboratory task that could replicate this, a task analysis based on observation of real tasks observed in plants A- D was derived. This is presented in section 3.4.1. .

Moreover, the interesting and challenging aspect in this research is the perception and interpretation of factors/ components of assembly operations through Armstrong's physical dose-capacity model and Wicken's Multiple resource model. The observed factors mentioned above could relate to these models and analysing their relationship might give a new theoretical approach for readers. For example, the assembly operations observed in plant A were fitting the parts at above shoulder height, under Takt time, which involved waiting, picking up the correct part out of many similar parts and memorise the coding that described which part belonged to which assembly. These factors could relate to the Armstrong dose-capacity model, which states that external factors (above shoulder height, Takt time,) lead to dose (cause disturbance due to shoulder height and short Takt time) and depending upon the capacity of the assembly operator, the response may lead to fatigue, physical workload and quality errors (dropping, assembly time).

Furthermore, the same task observed in plant A could also relate to the Wicken's multiple resource model as the task consisted of simultaneous performance of cognitive tasks, which seemed to require different resources when determining the perception-cognition-selection and execution activity. The cognitive activities in plant A for example arrival of which model at the work station required resources (that belonged to perception and cognition), which could be different from the resources used in picking up the correct part out of many similar parts (that belonged to selection and execution). Therefore the observed task in plant A seemed to have different cognitive

activities, which may use the same modalities which would lead to task interference (resulting in increased errors). Specifically, the cognitive activities observed during the task in plant A, which could have relation with MRM model, were determining which model was arriving at the workstation (perceptual stage), getting the code and memorise it while walking to shelf (visual and verbal), picking out of many similar parts (visual selection) then walk back to the workstation and finally identify the arm posture and fix the part at the required place (manual). These observed activities seemed to involve simultaneous performance of cognitive demands and therefore, according to Wicken's MRM model, require resources (verbal or auditory) while perceiving and interpreting the visual or spatial task. This may further lead to task interference depending upon the cognitive activities (cross modal or intramodal) required in the task.

The task analysis in the next section discusses in detail each activity (physical and cognitive) for designing the experimental study in order to understand the research question.

3.4.1 Developing a task analysis

Table 3.1 summarises the assembly tasks observed in the industries during the visits. Specifically, assembly tasks that involve the simultaneous performance of physical and cognitive demands have been highlighted. In order to further understand the research questions, a simulated assembly task has been designed (see chapter 4) based on simultaneous performance of physical (arm posture levels, repetition assembly) and cognitive (pacing levels and memory) demands.

Figure 3.3 and 3.4 show the pictorial view and Hierarchal Task Analysis (HTA-1) (Shepherd, 1986) of the task performance observed at plant-A. This can be

taken as a generic assembly task that can be simulated to conduct the laboratory study for the following reasons:

- It is representative of MMAL-type tasks
- There were instances of physical load (working above shoulder height)
- There was pacing / Takt at a reasonably short-time frame (approx. 3 minutes) which is typical for assembly Takt, and can be simulated in the laboratory
- There were examples of cognitive load (memory demands and mixed models).

Figure 3.3 demonstrates the mixed model assembly line with workstation carrying different models (e.g., A1, A2 and A3) being processed through workstations in sequence order. At the workstation assembly operator confirms for the model and gets the instruction/ code for the required part to be assembled at the automobile. The operator walks to shelf where the parts of different models are lying with their separate code according to the model. The assembly operator then finds the required part, picks it up and walks back to the assembly for fixing the part. The workstation time/ Takt time is fixed depending upon the customer demands.

Industry	Assembly factors	Physical factors	Cognitive factors
Plant A	<ul style="list-style-type: none"> • Paced assembly / moving assembly line • Assembly of different models of automobile being processed through mixed model assembly line under Takt time of 3.3 minutes 	<ul style="list-style-type: none"> • Walking between workstation and shelves • Assembly at different arm postures • Carrying parts from the shelf to the workstation 	<ul style="list-style-type: none"> • Getting instruction from the card attached on automobile • Self check for the quality of parts and assembly • Memorising the information/ code for the part to be picked from shelf • Picking right part out of similar parts for the particular automobile
Plant B	<ul style="list-style-type: none"> • Stationary assembly of longer cycle times • Assembly of module 1 of engine 	<ul style="list-style-type: none"> • Awkward postures of neck and arm during installation of blades • Heavy material handling by operators 	<ul style="list-style-type: none"> • Follow design and instruction to perform the complex assembly tasks • Correct blade to be fixed at correct position
Plant C	<ul style="list-style-type: none"> • Paced assembly line with Takt time of 13 minutes • Assembly of backhoe arm 	<ul style="list-style-type: none"> • Manual material handling of parts and tools • High exposure of arm during assembly 	<ul style="list-style-type: none"> • Self checking the parts for quality before assembly
Plant D	<ul style="list-style-type: none"> • Stationary assembly of large assemblies • Crusher assembly • Engine assembly • Fixing hosing 	<ul style="list-style-type: none"> • Manual material handling • Awkward posture 	<ul style="list-style-type: none"> • Follow design/ instructions • Task complexity • Time pressure

Table 3.1: Observation of assembly tasks under physical and cognitive factors

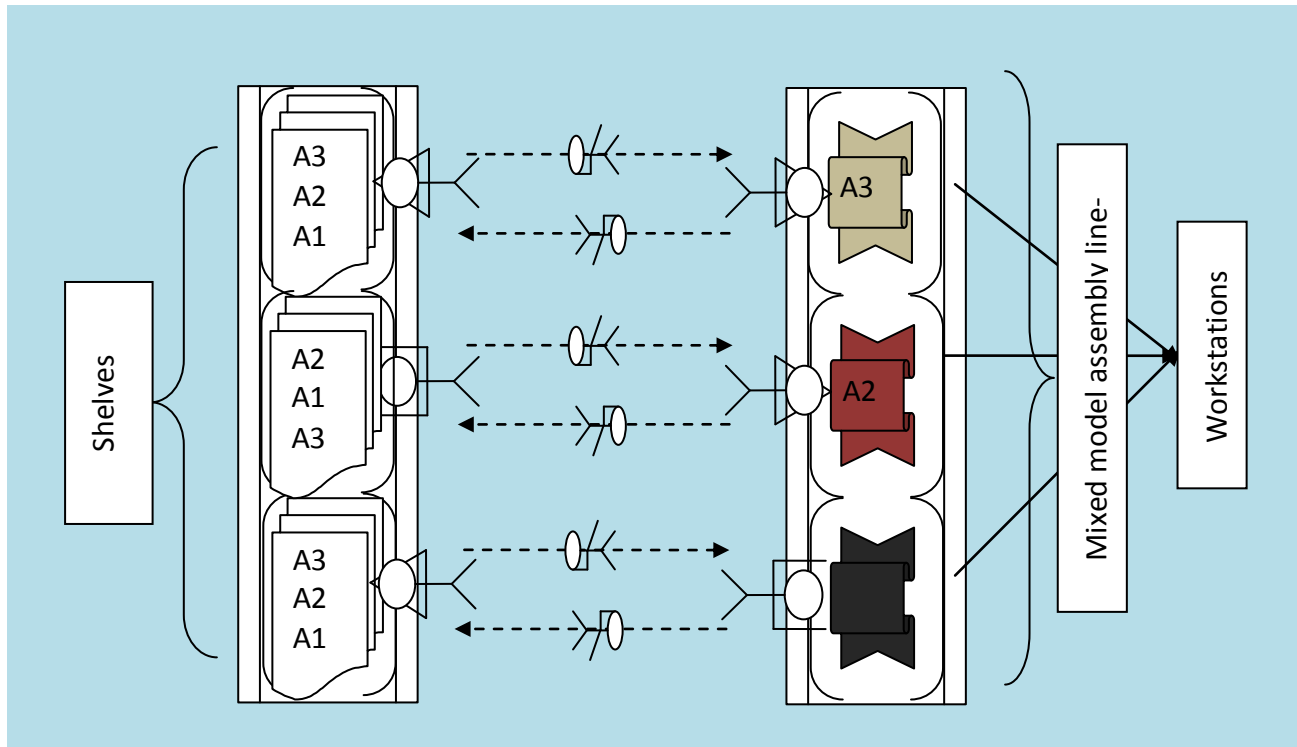
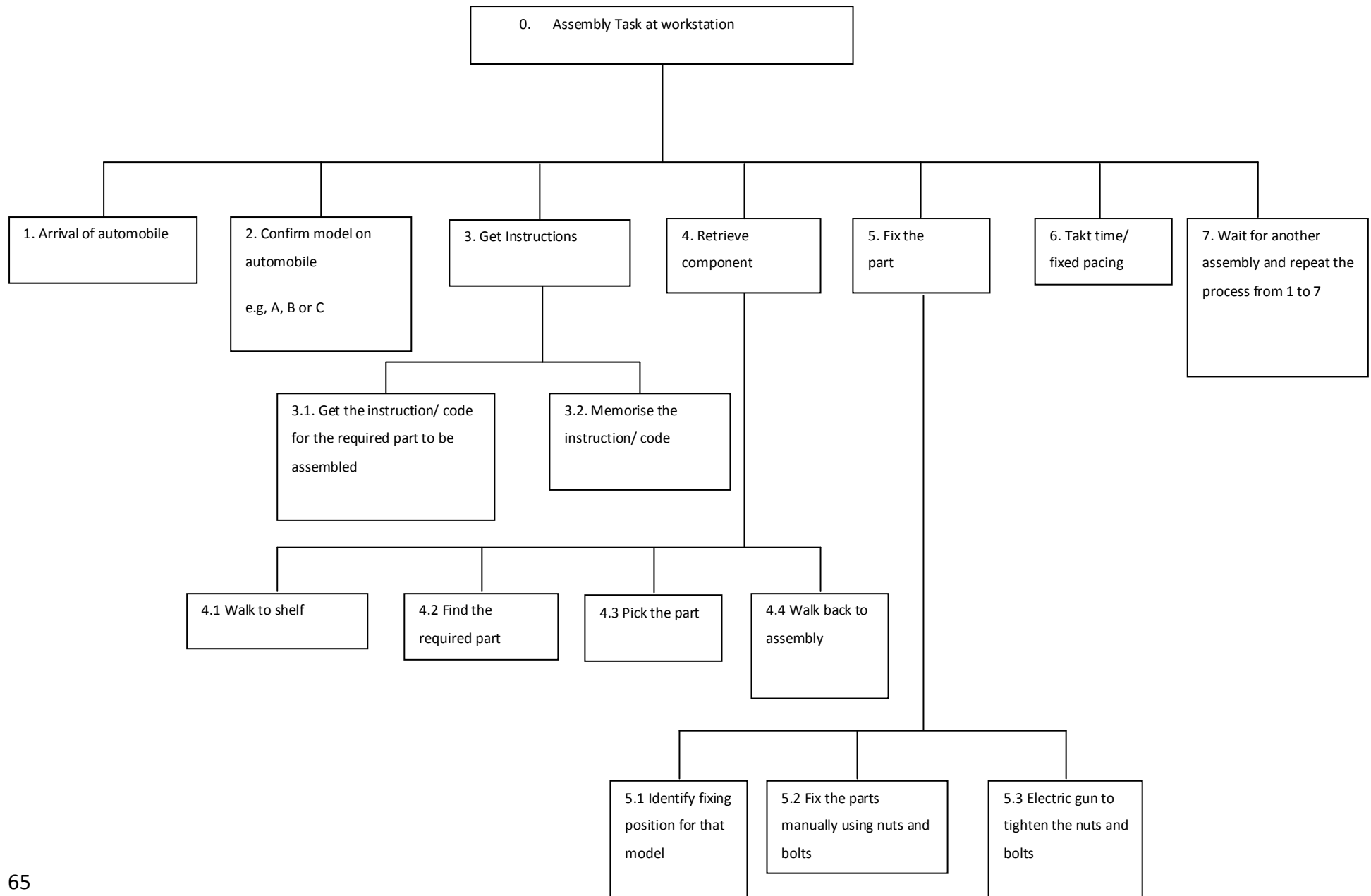

Figure 3.3: Pictorial view of task observed at plant A



Plan 0: Before carrying out the tasks 3 to 7, do 1 and 2 for the confirmation of automobile arrive at the workstation

Plan 3: do 3.1—3.2 to get the required information for the part then do plan 4

Plan 4: do 4.1 and then together do 4.2-4.3 and 4.4, then do plan 5

Plan 6: follow the fixed pacing/ Takt time, if plan 5 done before Takt time, do plan 7 and repeat 1 to 7.

Overleaf Figure 3-4: Task analysis of workstation assembly

3.5 Conclusion

In order to develop the link between the literature review, which revealed the gap of interactive effects of physical and cognitive demands on the quality of performance, and the PhD research aims, different assembly tasks were analysed under the category of physical and cognitive demands (shown in table 3.1).

Familiarization of assembly tasks during plant visits in different industries identified how physical (posture, material handling) and cognitive (following instruction, memory, quality check) factors due to pacing/ Takt time could affect the performance of an assembly operator. Since the focus of industry visits was to familiarise with the assembly operation especially task related to Takt time, of four plant visits (Plant A, B, C and D as mentioned above), plant A was found to be more specific to the required area that related to simultaneous performance of physical and cognitive demanding task. Plant A was assembling automobiles being processed through workstations in moving assembly lines under fixed Takt time. The task was found to have both physical and cognitive demands, which were being performed concurrently by an assembly operator. The current trends (for example, increased customisation, and product variety, mixed model assembly line) however, may put negative effects on the performance in case of reduced pacing/ Takt time. It is therefore, needed to explore and determine the interaction between physical and cognitive demands and their effects on performance under different pacing levels.

Furthermore, the physical demands (for example arm posture, material handling and walking between workstation) and cognitive demands (for example, code memory, instructions, quality check) identified during the industry visit in plant A, could have relations with Armstrong dose-capacity model and Wicken's multi-resource model, which are discussed in detail in

chapter 2. From this, a hierarchical task analysis (HTA-1) has been presented to show the step by step performance of the assembly task observed at Plant A. The related assembly task has been simulated for conducting the laboratory study. The detailed description about the design of task and methodology carried out to measure the quality of performance are discussed in chapter 4.

4 Methodology

4.1 Introduction

The purpose of this research in this thesis is to determine whether there is an interaction between physical and cognitive demands in their effects on performance and worker perceptions. This includes understanding the effects of pacing. Chapter 3 ended with the introduction of a Hierarchical Task Analysis (HTA 1; Figure 3.4) that described the step by step performance of a generic assembly operation, derived from observations of current practice in a sample of manufacturing industries. In this chapter, HTA 1 is used as a basis for design of an experimental study conducted in the laboratory in order to understand the impact of pacing levels on assembly operation performance and cognitive and physical demand. This chapter describes the design of the simulated single assembly operation, and choice and methodology used to measure required variables.

4.2 Background

Before presenting the experimental study, key points from the literature review and industry observations are discussed in order to show the rationale for some of the decisions made in planning the experimental study to achieve the research objectives.

The literature review in Chapter 2 showed that in modern manufacturing assembly work there are many demands for work to be completed in accordance with fixed speed rates (pacing), timeliness (working to deadlines), whilst also maintaining quality (Lin, 2001). Many research studies have focused on the impact of operator performance (physical capacity), muscle activities, back injuries, and fatigue. For example, studies related to lifting tasks, have shown that increase in the size of an object or the number of lifts per minute lead to fatigue and back disorders (Mirka et al., 1994). Physical workload can affect performance by influencing the muscular activity of the operator (Laursen et al., 2002, Sood et al., 2007). Other factors such as pacing and repetitive tasks have also a major influence on assembly operation tasks

(Bosch, 2011; Hagg, 2003). Assembly jobs require, besides lifting parts and handling materials for the assembly process that operators must use their mental functions including perception, attention and memory to complete the assembly operations (Richardson et al., 2006; Stork and Schubo, 2010).

Observations made during the industry visits confirm that these issues are still relevant in current tasks related to Takt time (low work pace and high work pace) were observed at plant A and plant B respectively. However, Takt time at both industries were high due to low customer demands during a period of economic downturn, which resulted in waiting time as operators were seen to have finished their workstation tasks before Takt time. Operators were also seen working at above shoulder height. Assuming that Takt time would be reduced when product orders increased, these postures could result in detrimental effects on the quality of performance. Task complexity was observed in all four companies in a variety of ways including following the design instruction for fixing hosing, memorising the part number/ code for automobile assembly, fixing blades in aero-engine at right place, and job rotation.

These observations showed that many of the issues in the literature, such as awkward posture and pacing, and cognitive load, are present in real assembly operations. There are also obvious examples of combined physical and cognitive work, for example in Plant D with assembly of hosing which was both complex and required awkward posture.

One of the aims of this thesis is to look at the interactive effects of physical and cognitive demands in relation to Armstrong dose-capacity model and Wicken's multiple resource model in order to understand the research question around how the different factors (physical and cognitive) are

perceived before task performance (see chapter 2), and what effects they have on the performance. As an example, assembly operators in plant A were found to be involved in simultaneously performing physical and cognitive demanding tasks under fixed Takt time, which could however, be interesting to analyse the performance considering Armstrong and Wicken's models. Research is however, lacking in determining the interaction between physical and cognitive demands in relation to these models.

Following the literature and observations, the next stage of the research programme is to undertake experiments in the laboratory, guided by the findings of the literature review and the observational study in industry. In all, three experiments were conducted, the second and third each being developed to extend the knowledge obtained from the previous experiment.

4.3 Experimental Setup

Three laboratory studies were designed to address the research objectives. These studies were based on assembly line operation/ workstation task, which involved fastening of wing nuts and bolts on to a metallic plate attached on a wooden bar (6 metallic plates, each with six holes, were attached to the wooden bar at equal gap representing the workstation activities). The fastening task in study 1 was performed on plain metallic plates. However, study 2 and study 3 were modified by sticking numbers near the holes at metallic plates. The numbers were arranged in random order representing mixed model assembly line and in sequence order representing single model assembly line. The task was chosen because it could be designed in to include the simultaneous performance of physical and cognitive demands to finish the fastening task. For example, work height could make the task more physically demanding, while varying the order in which bolts were required to be fastened to the plate could make the task more cognitively demanding. The detailed description about the task and activities

representing physical and cognitive demands actually used in the studies is discussed in the following sections.

The design of the experiment was to simulate a real assembly operation, based on observations made at plant A. The Takt time of the workstation at the time of observation was fixed for all the workstations in that assembly line at approximately 3 minutes. This was set according to the customer demands. It was clear that this was more time than the task required time as the operator finished the assembly in time and waited for the next assembly to arrive at work station. During the observation the operator selected a component for the particular automobile from a store at a few steps away from automobile. There were automobiles with different colours and shapes being processed on the assembly line one after the other and operator had to select the right part for the right product. Even though, the part was quite similar for all automobiles, they had to match coding on the part with the relevant product.

This task was described in HTA 1. This task analysis was adapted to make it practical to simulate in the laboratory. This is described in HTA 2, in Figure 4-1. The simulated single assembly operation consists of five main activities represented as five plans. Each plan is further divided into different steps, which must be carried out while performing the task activities depending upon the required conditions / levels (described below). Figure 4-2 shows the complete set up of the experiment. The right hand side shows the attachment of six metallic plates on the wooden bar. The arrangement of six plates was set to provide a sufficient space between the plates in order to perform the single assembly operation without any hindrance as the necessary requirement for setting up the experiment in the laboratory. The six metallic plates in a row on wooden bar represent the assembly line and each metallic plate represents the workstation task. Each assembly line was constructed as

a wooden bar with six metallic plates, presenting assembly operation task. Underneath each assembly line wooden bar, another wooden bar with six bins is also attached 150mm below the assembly line wooden bar as mentioned by Kroemer and Grandjean (1997) that during manual work, an operator often needs space for tools, materials and containers of various kinds, and suitable heights for these 100-150 mm below the elbow height. Each bin contained nuts and bolts that were used for the relevant assemblies. The wooden bars are then fixed at either elbow height and above shoulder height. The height of the bar was varied for the independent variable of physical demand, described below.

Following the HTA presented in chapter 3, the task is performed as follows.

Plan 1 - The participant first comes to the computer A screen and presses the Enter key on key board. They see the code, which disappears after three seconds. A text box appears where the participant writes the same code and presses Enter. This simulates receiving complex assembly instructions as seen in observations.

Plan 2 - The participant then walks to the assembly line, as seen in observations.

Plan 3 – The participant presses enter on keyboard B to indicate they are ready to start assembly (this also starts the pacing timer in paced conditions). They perform six assemblies using parts in the bins below each assembly piece. The ordering of parts varies depending on the study (described in chapters 5, 6 and 7) simulating Single and Mixed Assembly.

Plan 4 – At the end of each assembly piece, the participant presses enter on keyboard B. If the participant is in a paced condition, they wait for the beep. This simulates Takt as seen in the observations at plant A. If, however, the participant is in a paced condition, and takes too long, computer B will beep and the participant has to press enter.

Plan 5 – The participant then walks back to computer A to re-enter the code. They then press enter to get the next code.

This is repeated six times for each of the assembly plates on the assembly line. At the end, the participant stops and is asked to complete a number of subjective measures (described in Section 4.5.2).

Two computer programs are generated using C –Sharp language in two different computers. Computer 1 (keyboard A as mentioned in HTA 2) displays the code and measures the code responses. This computer program also measures proportion of complete cycle time, which includes code entry time before assembly operation and after assembly operation and the total time of the assembly. Computer 2 (keyboard B as in HTA 2) measures the actual assembly time and also give the auditory signal for pacing (Takt time) control. The step wise description of program is shown in figure 4-3.

The design of the experimental task in this way allowed the investigator to control physical demands (working at either elbow height or above shoulder height) and cognitive demands (memorising a code of different lengths during the single assembly operation) and pacing demands (no pacing, low pacing/Takt and high pacing/Takt). These are described further in the next section.

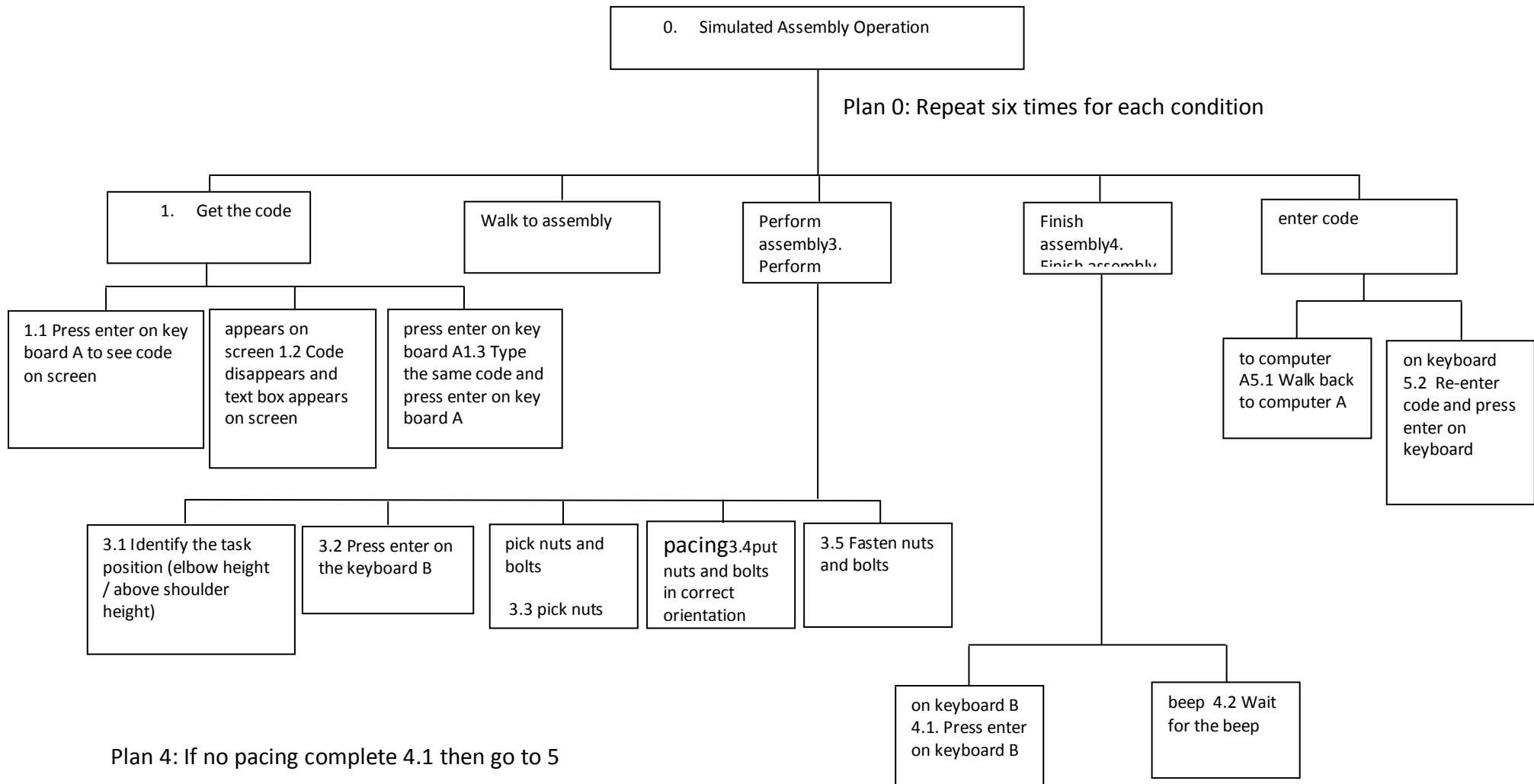

Plan 4: If no pacing complete 4.1 then go to 5

If in pacing and complete before beep, do 4.1 – 4.2 then go to 5

If in pacing and incomplete at beep, do 4.1 and then go to 5

Previous page Figure 4-1: Hierarchical task analysis for the simulated assembly operation

Following Figure 4-2: Complete set up of single assembly operation

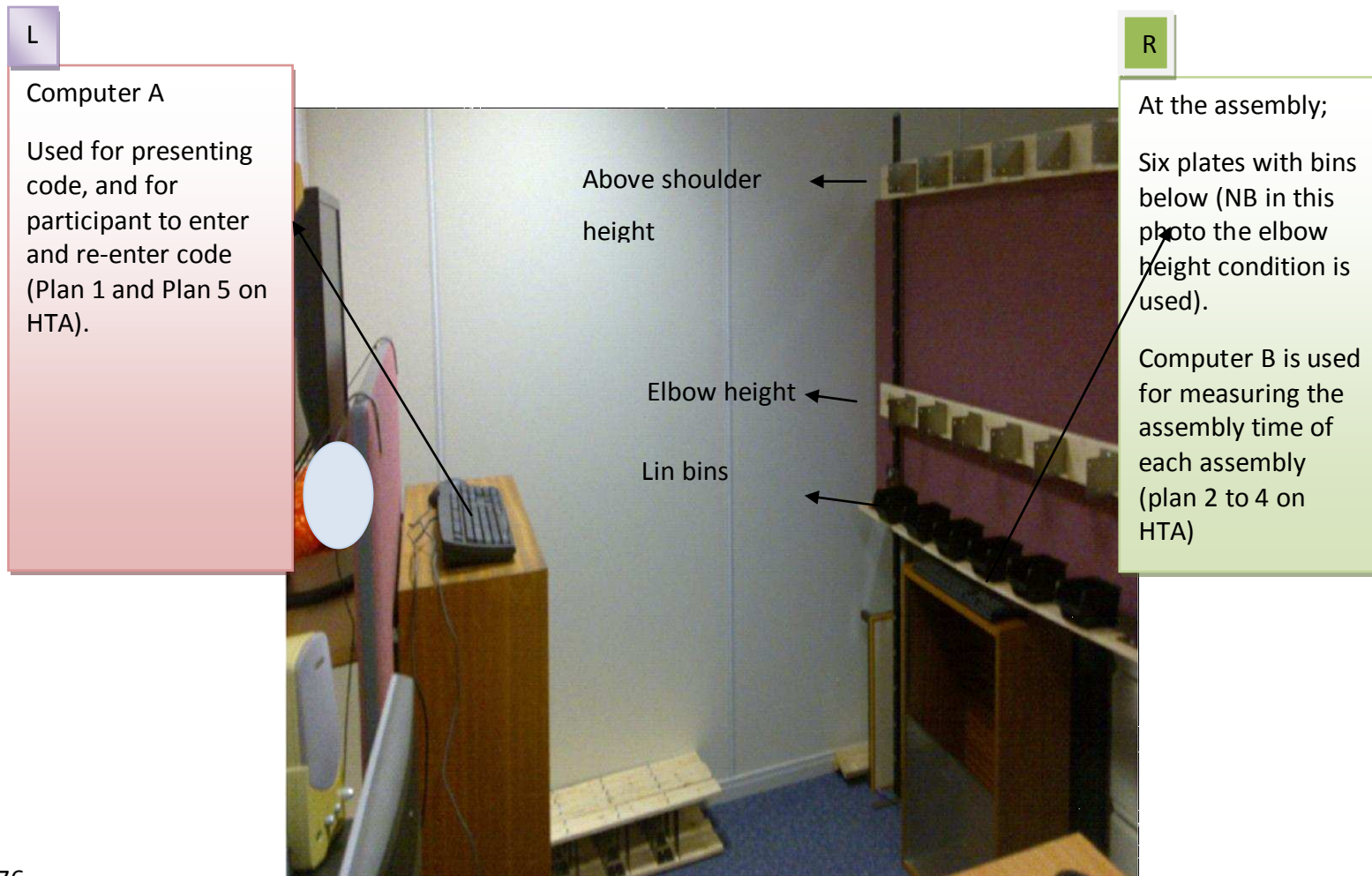

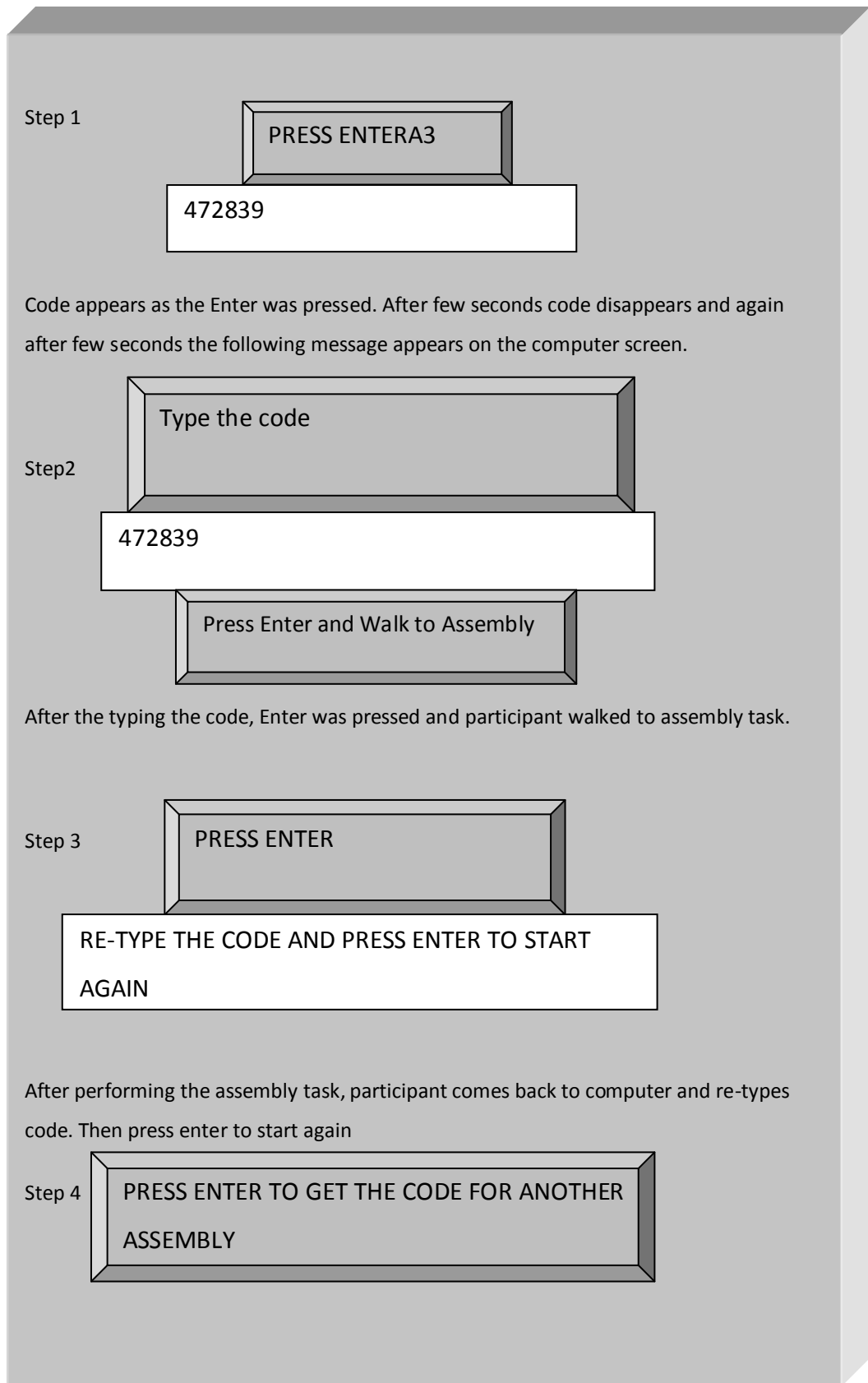

Figure 4.3: Computer Application design

The HTA described above therefore described a laboratory assembly activity. In comparison, Richardson et al (2006) carried out hierarchical task analysis in order to identify the fundamental steps during an assembly task and understand what impact they leave on cognition and therefore affect the assembly complexity. The assembly was split into five sub-operations (component sort, select component and fastening of assembly, orient component, adjust relative positioning of components and fasten components). Furthermore, Tan, et al., (2008) carried out a hierarchical task analysis to model the collaboration between human worker and robot manipulator in a cable assembly operation in cell production. Their analysis involved the understanding of the assembly task, human worker and robot manipulator task definition, and the collaborative working sequences between man and machine. The main goal in the hierarchical task analysis was to 'assemble cable on a marking board', termed as goal (0). The main goal was followed by 4 sub-goals: secure cable contact on connector, temporary fix cable end, set connector on marking board and form the cable on marking board.

The work of Richardson, et al., (2006) and Tan et al., (2008) demonstrates the way to design and develop simulation studies that can be carried out in the laboratory in order to understand the different steps carried out during assembly operations and factors affecting the assembly complexity. This forms the basis for the current research to carry out hierarchical task analysis on the observed assembly operations in manufacturing plants visited, in order to understand the steps involved in designing the simulated assembly operation. The HTA presented above is similar to assembly operations described by Richardson and Jeffrey in that they both used assembly operation. However, the work of Richardson (2006) is similar in that it includes fastening and procedures that may affect the cognitive complexity. The Tan, et al., (2008) HTA was applied to a simulation study based on carrying out HTA on assembly

operation that worked for improvements in assembly completion task with less errors, demonstrating that this kind of HTA and assembly is relevant to the laboratory study of assembly.

The laboratory assembly task is different from those described by Richardson (2006) and Tan, et al., (2008), however, in that it is not a 'full' assembly. It does not involve multiple parts being used to complete a complete component. Instead, it takes a single assembly operation (fixing nuts and bolts to a plate) as an example of an assembly-type task. This approach has been used as it makes the laboratory task more flexible, makes it easier to control cognitive demand and physical demands in the assembly task. In the following chapters, the term 'assembly task' is used but it should be remembered the assembly task is describing a simple assembly operation.

4.4 Independent Variables

Three variables were chosen as independent variables to present different types of demands that could be present in manufacturing assembly operations. These were:

- work height – representing physical demand
- memory load – representing cognitive demand
- pacing – representing time demand.

4.4.1 Physical demand

As discussed in chapter 2, the physical characteristics in assembly operation include posture, walking, fetching, material handling, inserting, fastening, which need to be well understood for the design of assembly operation. Many researchers have discovered a significant relationship between workstation design or postures on one hand and incidence of discomfort and medical findings on the other hand (Grandjean, et al. 1983; Laubli, et al. 1986). Apart

from issues related to musculoskeletal disorders, research has also pointed out the problems related delay in task completion, increased number of drops, general fatigue due to working at different height (for example; Sood et al., 2007; Bosh, et al., 2011).

Keeping into considering the above discussion especially related to performance at different working height, industry visits were carried out to observe the physical characteristics that may impose physical stress/ fatigue. During the industry visits, operators were seen to have performed their assembly operations at different arm postures, which included working at elbow height and above shoulder height (discussed in detail in chapter 3). These postures in future with reduced Takt time and demand for variety of products (Mixed Model Assembly Line (MMAL) may impose physical stress.

Therefore, in the simulated single assembly operation working height based on arm posture was used as the IV representing physical demand with two levels:

- elbow height – this is a posture used for normal tasks as it puts minimum exposure to shoulders and back (Grandjean and Kroemer, 1997)
- above shoulder height – this is a posture that develops fatigue in shoulders and upper arms (Grandjean and Kroemer, 1998; Sood et al., 2007). It was also observed during industry visits, and is therefore a realistic posture.

4.4.2 Cognitive Demand

As discussed in Chapter 2, cognitive demand can be understood as mental workload (MWL). Mental workload in assembly can come from a number of different sources – from the complexity of the assembly (Richardson et al., 2006), from complexity due to needing to identify a number of different parts, or from the having many different types of product on the assembly line (Zhu et al., 2008).

During the industry visits, operators were also seen to perform complex tasks that required mental effort to understand the task and then utilized their mental effort to perform the required activities. The tasks that could impose mental stress due to cognitive demands include; following the design instruction (e.g. on hose assembly at Plant C and D), memorising the code/ part specification at Plant A and B, self check for the quality during assembly (Plant A and C), fixing of blades in aero-engine at right places (Plant B), and reduction of Takt time/ workstation time in future (Plant C).

The current study, therefore, included a cognitive load on working memory, similar to needing to remember task instructions or assembly component details. This was implemented as a memory code which was presented before the assembly operation and then needed to be re-entered after the task. Different levels of the IV were implemented using different lengths of code. For example, in Study 1, low demand was a four digit code, and high demand was a six digit code.

4.4.3 Pacing

Production engineers devise economical means of performing a task and determine how much time should be allotted to operators (Barnes 1963) to optimise time allocation and accommodate average performance. It was observed during industry visits that operators were working under fixed pacing. However, due to low to Takt time operators were seen waiting for the next assembly to arrive at the workstation. Low pacing may cause underload, which could result in increased number of errors. Therefore, pacing was used as the IV representing time demand with three levels:

- no pacing,
- low pacing/ low Takt time (as observed in Plant C)
- high pacing/ high Takt time.

4.5 Dependent Variables

Much research has been carried out to assess the physical and cognitive attributes of tasks using physiological, objective and subjective measures. However, previous studies showed conflicting findings with respect to the relationship between physical load and basic cognitive tasks performance. Recent studies conducted by DiDomenico and Nussbaum, 2008, DiDomenico and Nussbaum, 2011, Basahel et al., 2010, and Perry et al., 2008) have shown the relationship between physical and cognitive demands using physiological measures, video recording, time to completed the task to analyse the objective measures and NASA TLX, Situation awareness, Borg CR 10 to analyse the subjective measures. It is therefore necessary to choose measures that are valid, and will capture data that will allow comparison of physical and cognitive demands with performance.

The following section presents dependent measures categorised into two groups – objective task performance, and subjective (perceived) physical and cognitive demands.

4.5.1 Objective measures - Performance

The present study is designed to investigate the effects of physical and cognitive demands on the quality of performance and subjective responses and to determine whether there is relationship between physical and cognitive demands. The simulated task consists of 3 independent variables, which have been discussed above. The independent variables have further been modified based on the results achieved in the corresponding studies, which are also discussed in relevant chapters. However, the dependent variables remained the same in all three simulated studies. The dependent variables have been selected based on industry observation and literature review.

In Bosch et al., (2011) errors was used to measure performance. Shaikh et (2012) and Sood et al (2007) identified recorded number of errors (number of fully completed assembly and number of drops) Sood et al. (2007) conducted a study Over head tapping task under three different heights. In a study conducted by Perry et al., (2008) task performance was measured in terms of helicopter loading rate and accuracy. DiDomenico et al., (2008; 2011) carried out the experimental study to determine the interactive effects of physical and cognitive demands on subjective workload using (Borg CR-10 and NASA TLX).

Based on the observation and literature, the following performance measures have been chosen. These were recorded continuously throughout the performance of each experimental condition (described in more detail in Chapter 5, 6 and 7).

4.5.1.1 Service time (measurement of actual assembly time)

Assembly time was measured using computer program as discussed above. Participants were instructed to press the Red key (Enter key on key board was coloured red) before start the assembly operation and press the red again as they finish the assembly or hear the beep. The detailed description of assembly time measurement in relation to pacing conditions is discussed in chapter 5. As the key was pressed, computer program started to measure time and time stopped when the key was pressed again after assembly operation was finished or beep was heard. Stop watch was also used to measure the assembly time, in case if participant forgot to press the red key before start the assembly.

4.5.1.2 Measurement of number of completed and loose assemblies

Number of completed assemblies was measured using observation sheet. After completion of the assembly operation, each assembly operation that consisted of fastening of 6 nuts and bolts was checked according to the instructions given to the participants that fastening of nuts and bolts should

finger tight. The completely fastened assemblies were recorded under number of completed assemblies, whereas, the loose and missing assemblies were recorded under loose number of assemblies.

4.5.1.3 Number of drops

Number of drops was recorded during observing the participant doing the assembly operation. Number dropped nuts and bolts were recorded for each assembly operation.

To support these measures an observation tool was developed. Observation sheet was prepared to record the data on each assembly operation. This was used by the experimenter to record the number of fully completed assemblies, the number of drops, and the number of loose nuts and bolts (those not fully tightened and missing during the assembly). The observation sheet is shown in appendix 2-C.

4.5.1.4 Number of correct responses

Objective cognitive performance was measured through accurate recall of code responses.

4.5.2 Subjective measures - Physical and mental workload

People experience workload (either physical or mental) while using different equipment or activities of the work system. Various techniques have been used to evaluate the workload in order to achieve the required objectives for the design of workstation and or set the guidelines for a particular task. Such measures include the Perceived Exertion (the RPE and CR10 scales) developed by Borg (1998), the Swedish Occupational Fatigue Inventory (SOFI; Ahsberg 1998), Physical Well Being Checklist (consist of body part diagram and rating of perceived fatigue scale (McAtmney, 1994)). However, none of these techniques record both physical and cognitive workload.

NASA TLX (Hart and Staveland, 1988) is a multidimensional technique used to measure workload. The multidimensional aspects include physical demand, cognitive demands, temporal demand, performance, effort and frustration. Each dimension is measured on visual analogue rating scale from 0 to 100. Different versions of NASA TLX have been used by researchers. It can be used in a weighted or unweighted form. The use of unweighted or raw TLX (RTLX) is the most common as the high correlation has been found between weighted and unweighted NASA TLX score (Byers, Bittner, & Hill, 1989; Moroney, Biers, Eggemeier & Mitchell, 1992, DiDomenico and Nusabaum, 2008). NASA TLX has been most favourably used by subjects, when compared with other subjective workload assessment techniques (e.g., SWAT, the Cooper–Harperscale), NASA TLX reliability for repeated measures has shown correlations of .77 (Battiste & Bortolussi, 1988). One of the main reasons of the popularity of the NASA TLX among researchers is its ease of implementation.

Another aspect of perceived workload is stress. Occupational stress occurs in case when an individual is unable to cope with the current situation/ work demands. Stress is basically considered as normal reaction or response of workers to the tasks that they feel unable to respond properly. Such reactions may enable the workers to find new balances and responses to new situations. However, negative stress appears if the task is intense, continuous or repeated, resulting in broad range of physical and psychological disorder, provided the task demands exposed to highly stressful situations (Wilson, 1998). The stress and arousal checklist (Cox and Mackay, 1985) and also, fatigue may come from high pace, and also from awkward posture and physical work. Bosch (2011) and Sood et al. (2007) both measure fatigue using the McAtamney (1994) fatigue rating scale. Therefore, the following dependent variables have been selected for current studies. These were recorded at the end of each condition (described in detail in Chapter 5, 6 and 7).

4.5.2.1 Raw NASA TLX

Workload was measured using Raw TLX (Moroney et al., 1992). Ratings were gathered from 5 dimension of NASA TLX. The dimensions were mental demand, physical demand, temporal demand, performance and effort. Each dimension was rated on a visual analogue scale, ranged from 0 to 20. The rating scales used are shown in appendix 4.

4.5.2.2 Stress and Arousal Checklist

To measure the stress and arousal, subjects were asked to describe their mood and feeling by 30 adjectives after each condition. If the adjective definitely described the feelings, they encircled ++. If it more and less described the feeling, they circled the sign of +. If they could not describe their feelings, they circled the sign of ?, and if it was against their feeling, they circled -. The long scale was used in which the stress score range was between 18 and 72 and the arousal score ranged between 12 to 48.

4.5.2.3 Fatigue

Fatigue score after each condition was recorded by using a rating scale (as used by McAtamney, 1994) from 0 (energetic, lively) to 10 (Extremely tired or fatigued). The physical scale of NASA TLX was also used to record perceptions of physical workload.

4.6 Relation with theory

The physical and cognitive factors as the independent variables have been incorporated in the simulated study design based on the HTA 1 of real assembly operation. The independent variables can be considered with respect to theoretical models presented in Chapter 2 to understand the complexity of task perception and performance in laboratory experiments.

In terms of Armstrong's dose capacity model (1993), the physical demand as an independent variable include posture, i.e work height at two levels and the work height could act as dose (i.e. cause disturbance). This dose relates to

capacity, which will be influenced by time pressure when Takt time is low (i.e. pacing is high), which may further lead to the responses that are hypothesised as physical (fatigue and body part discomfort) and psychological (NASA TLX and stress and arousal). As well as these subjective perceptions of the operator, there will be an effect on subjective performance measures, for example task completion time, or errors and drops.

The cognitive variables include code memory at two levels and order of fastening nuts and bolts (which represent single model assembly and mixed model assembly). These selected cognitive independent variables, according to Wicken's MRM model, represent verbal (memory and pacing) and visual-spatial (order of fastening nuts and bolts) tasks that require resources (verbal or auditory) for task perception and performance. The complexity of verbal and spatial task, depending upon the limited capacity of attention resources may lead to response related to increase NASA TLX, stress and arousal level.

The simulated design involves the simultaneous performance of physical and cognitive demanding tasks that are discussed above in relation to Armstrong's dose-capacity model and Wicken's multiple resource model.

4.7 Summary

This chapter discussed the research methodology that included the research program, design of experiment and tools used to carry out the experimental study.

Based on literature and observations reported in chapter 3 the general structure for the study is

- The introduction of the new simulated assembly operation in the laboratory, which shows the assembly line with the workstations.

- The task is designed considering the assembly operations involving simultaneous performance of physical and cognitive demands (mentioned in HTA 2)
- Product variety (mixed model assembly line), workstation/ time and posture due to work height are the main characteristics involved in the assembly operation
- Pacing (no pacing, low pacing/ low Takt time and high pacing/ high Takt time), work height (elbow height and above shoulder height) and memory (low memory and high memory) are selected as independent variables in the study design
- Both objective and subjective measures that are taken as dependent variables. These include
 - objective performance (task time, errors (drops and loose assemblies), drops and code recall)
 - subjective measures (NASA TLX, stress and arousal, fatigue)

The simulated design therefore, aims to understand how different levels of physical and cognitive demanding combinations affect the verbal and spatial visual tasks. The detailed description of each study is discussed in the relevant chapter – chapter 5 (study 1), chapter 6 (study 2) and chapter 7 (study 3).

5 Study 1- Investigating effects of physical and cognitive demands under different pacing levels

5.1 Introduction

Chapter 4 introduced the research programme and methodology for conducting the laboratory studies in order to achieve the required objectives. This chapter describes the first study of the research programme, which was aimed at investigating the effects of physical and cognitive demands (and any interaction) on the task performance and subjective responses.

Following on the issues (in literature review and familiarities of real tasks in industries) related to physical and cognitive demands in assembly operations, a simulated study was designed to understand the physical and cognitive aspects during simultaneous performance and determine whether they interact with each other.

The present study was undertaken to investigate the effects of pacing (such as the imposition of Takt time) on aspects of task performance and on assembly workers' responses related to work behaviour, trade-off between speed and quality, perceived workload and perceived stress for a single operation assembly task that demanded both physical and cognitive effort. The aim of the study was to investigate whether physical and cognitive demands may interact in their influences on these effects. The study was designed to capture performance measures (including task quality, successful task completion and accuracy at the memory load element of the task) as well as subjective measures (including NASA TLX (Hart and Stavenland, 1988) and the stress and arousal checklist (Cox and Mackay, 1985)).

5.2 Experimental hypotheses

Chapter 2, 3 and 4 have discussed in detail about the physical and cognitive aspects involved in assembly task performance. Therefore, taking into consideration the introduction regarding the interaction between physical and cognitive demands (DiDomenico et al., 2008 and 2011; Bahsal et al., 2010; Perry et al., 2008), the current study hypothesises that

1. The three levels of pacing, which includes no pacing, low pacing/ low Takt and high pacing/ Takt time may cause significant effects on both objective response (actual assembly time, number of code responses, number of completed assembly, number of drops and walk time between assembly and shelf) and subjective responses (NASA TLX ratings, stress and arousal score, fatigue ratings and body part discomfort).
2. The two levels of work height (elbow height and above shoulder height), may cause significant effects on both objective response (actual assembly time, number of code responses, number of completed assembly, number of drops and walk time between assembly and shelf) and subjective responses (NASA TLX ratings, stress and arousal score, fatigue ratings and body part discomfort).
3. The two levels of memory load (low memory load and high memory load), may cause significant effects on both objective response (actual assembly time, number of code responses, number of completed assembly, number of drops and walk time between assembly and shelf) and subjective responses (NASA TLX ratings, stress and arousal score, fatigue ratings and body part discomfort).
4. There may be interaction between the effects of physical and cognitive demands.

5.3 Task Analysis

As explained in Chapter 4, the experimental task was a simplified simulation of a task performed at a workstation on a paced assembly line where the cycle time was controlled by a Takt time system. The cognitive element of the task was to read (from a computer display) and remember the code for the next assembly, which was performed at a specified cycle time. The physical element of the task was to attach nuts and bolts to a plate.

Figure 5-1, takes the HTA from Chapter 4 and shows each activity performed during the simulated assembly task under three levels of pacing (Takt time in case of low pacing and high pacing), two levels of posture and two levels of memory load.

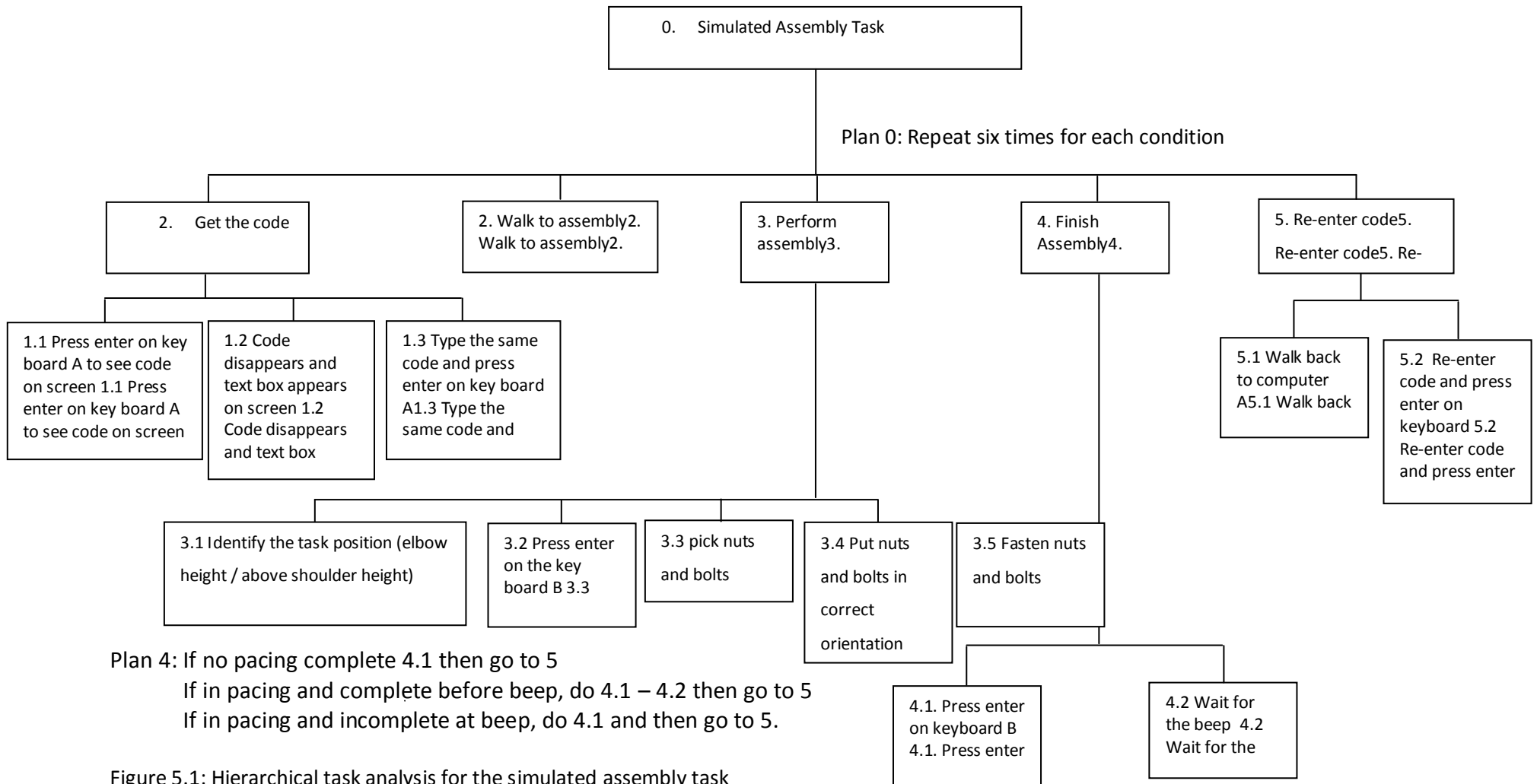

Figure 5.1: Hierarchical task analysis for the simulated assembly task

5.4 Method

5.4.1 Participants

Twelve participants (6 male and 6 female), between 23 and 50 years (mean 30.7, SD 7.3 years), were recruited for the laboratory experiment from the students and staff of the university. All participants signed an informed consent form. The study was approved by the local ethical review committee.

5.4.2 Experimental design

The physical aspect of the task in the laboratory simulated a simple assembly of components and consisted of attaching and tightening six wing nuts on threaded bolts. This was repeated for 12 cycles in each experimental condition. There were six assembly operations in a row. Each condition was performed twice and the number of correctly fastened nuts and bolts (finger tight) out of 72 assemblies was recorded in each condition. The task was performed while standing with the work height being at either elbow level or above shoulder level. The cognitive aspect of the task was to memorise the product code number (as presented on a computer screen) and to enter this number immediately before starting the assembly and then again after its completion. The code was generated randomly for each assembly. Figure 5-2 and 5-3 show a participant performing different aspects of the experiment.



Figure 5.2 A: Getting code for the assembly



Figure 5.2 B: Presses Red key before start the assembly



Figure 5.3 A: Performing assembly at above shoulder height



Figure 5.3 B: Performing assembly at elbow height

5.4.3 Independent Variables

The task was performed under each of three pacing conditions (each on a separate day): with no pacing at the participant's preferred speed of work (control condition), at a low level of pacing with 90 seconds allowed for each assembly, and at a higher level of pacing with 60 seconds allowed for each assembly. These times were chosen after a short pilot, where 60 seconds was an approximate average time to complete the task, and 90 seconds left much spare time at the end of the task. Task time at low pacing (90 seconds) and high pacing (60 seconds) was controlled by a computer beep signal.

The independent variables and the levels are listed in table 5-1. Three levels of pacing, two levels of pacing and two levels of memory load produced 12 experimental conditions. Participants performed all the 12 conditions on three different days. Within each level of pacing the four conditions were presented in random order. A five minute practice session was provided to allow the participant to familiarize him/herself with the task.

Independent variable	Level	Description
Pacing (by Takt time)	No pacing	At own preferred speed (No Takt time)
	Low pacing	Takt time 90 seconds
	High pacing	Takt time 60 seconds
Physical demand (work height)	Elbow height	Lower arm parallel to ground making 90 degree with the lower arm
	Above shoulder height	Upper arm parallel to ground making 90 degree with the upper arm
Cognitive demand (memory load)	Low load	Memorising 4 digit code
	Higher load	Memorising 6 digit code

Table 5-1: Independent variables

5.4.4 Procedure

Figure 5-4 shows the sequence of procedure for the performing the assembly task under no pacing, low pacing and high pacing conditions.

5.4.5 Instructions to the participant

The following instruction were given to the participants

General Instruction

- Participant entered into the human factors laboratory.
- Participant was asked to sit on the chair and get relaxed
- Participant was given Information sheet, Consent form and General well being questionnaire to read and sign the concerned forms
- Participant was given instructions about the task by the researcher
- After completion of all the pre task documentation, participant was asked to perform 5 minutes practice task.
- Participant was asked whether he/was completely familiarise with the task.
- Participant was asked whether he/ she was ready for the main task.
- Participant was taken to experimental setup where the participant was demonstrated about the task performance
- Participant was asked to get the code from the computer display and memorise the code during assembly.
- Participant was asked not to bend down to pick the nut or bolt from the ground in case of the falling down of the nut or bolt

Instruction for no pacing conditions (own speed)

- Participant was asked to perform the task at own speed.
- After finishing the condition that required to complete six repetitive assemblies, participant was asked to complete the subjective responses (shown in appendix 3)

Instructions for low pacing (Low Takt time)

- Participant was asked to finish assembly in 90 seconds.
- Participant was asked to press red key on the key board before start the and also press the red key as they finish the assembly or hear the beep. After hearing the sound, participant stops the task and moves for the other task.

Instructions for high pacing (high Takt time)

- Participant will be asked to finish assembly task in 60 seconds.
- Participant was asked to press red key on the key board before start the and also press the red key as they finish the assembly or hear the beep. After hearing the sound, participant stops the task and moves for the other task.

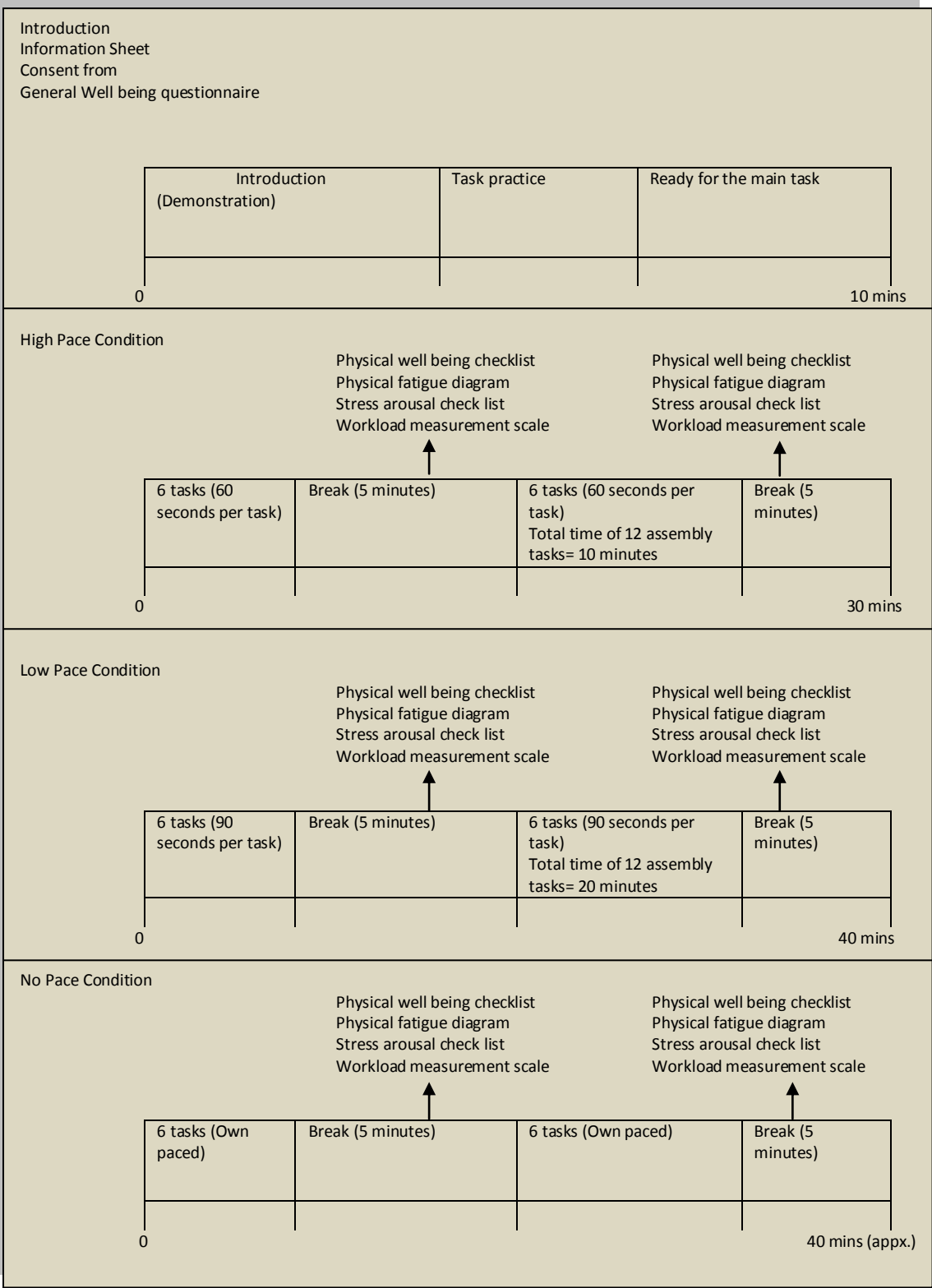

Figure 5-4 Sequence of procedure

5.4.6 Dependent Measures

Both objective and subjective measurements were made (as discussed in detail in chapter 4, section 4.5). The code responses typed by the participants and the time for each activity was recorded on computer. An observational record was made of the quality of tightening of nuts and bolts, numbers of dropped nuts and bolts, and numbers of fully completed assemblies.

Participants were also asked to provide a subjective assessment of their perceptions of the physical and mental workload. The assessment of the physical workload was obtained using a physical well-being checklist questionnaire (including a rating of fatigue) and a body part discomfort diagram. Raw NASA TLX data (Moroney et al., 1992) was used to assess the subjective mental work load based on ratings on five subscales: mental demands, physical demands, temporal demands, performance and effort. A Stress and Arousal checklist was also used (Cox, 1985).

5.4.7 Statistical analysis

A paired comparison t-test was conducted to analyse the difference in each of the measures for the two repetitions of each condition. No significant effect was found and therefore the data was merged for further analysis. Analysis of variance (ANOVA) for repeated measures was used to test the effects of pacing, work height and memory load on objective and subjective responses. The significance level was set at $p < 0.05$.

5.4.8 Test for Assumptions

The data for each condition of the dependent variable were tested to check whether the assumptions for analysis of variance (ANOVA) were met. These included Mauchly's test for sphericity and z-skew to test for normality. If the tests identified z-skew $> +$ or $- 1.96$ in any of the experimental conditions, then appropriate data transformation was applied to the entire data set and the ANOVA test performed on the transformed data. In all cases (including where the statistical analysis tests had been conducted on transformed data), presentation of descriptive statistics and interpretation of mean scores use

the raw data values in order to provide meaningful interpretation. The tests for assumptions are further discussed for each dependent variable in relevant sections.

5.5 Results

5.5.1 Objective measures

A Three-way (3x2x2) repeated measure ANOVA was performed to find whether the effects of the three independent variables on time performing the assembly, time walking between different parts of the workstation, number of correct code responses, number of fully completed assemblies, and number of dropped nuts and bolts were significant.

The data was analysed using univariate tests for within subjects and pair wise comparison using least significant difference test was carried out to conduct the post hoc analysis.

5.5.1.1 Actual Assembly time

Each condition consisted of six simple assembly operations and the actual time of each assembly operation was measured using computer generated program. Each condition was performed twice and therefore, the data was collected for 12 assembly tasks. Table 5-3, shows the mean value and standard deviation of performance time in each condition and Figure 5-4 displays the mean performance time and standard error for each condition graphically.

No pacing				Low pacing				High pacing			
Elbow height		Above shoulder		Elbow height		Above shoulder		Elbow height		Above shoulder	
Low	High	Low	High	Low	High	Low	High	Low	High	Low	High
741.08	722.58	784.08	749.25	749.58	756.50	778.25	777.33	655.33	662.83	683.92	690.92
(26.7)	(21.3)	(37.3)	(31.1)	(33.5)	(33.0)	(31.5)	(29.7)	(16.9)	(18.9)	(13.8)	(13.2)

Table 5-3: Mean(SD) of each condition on Assembly time

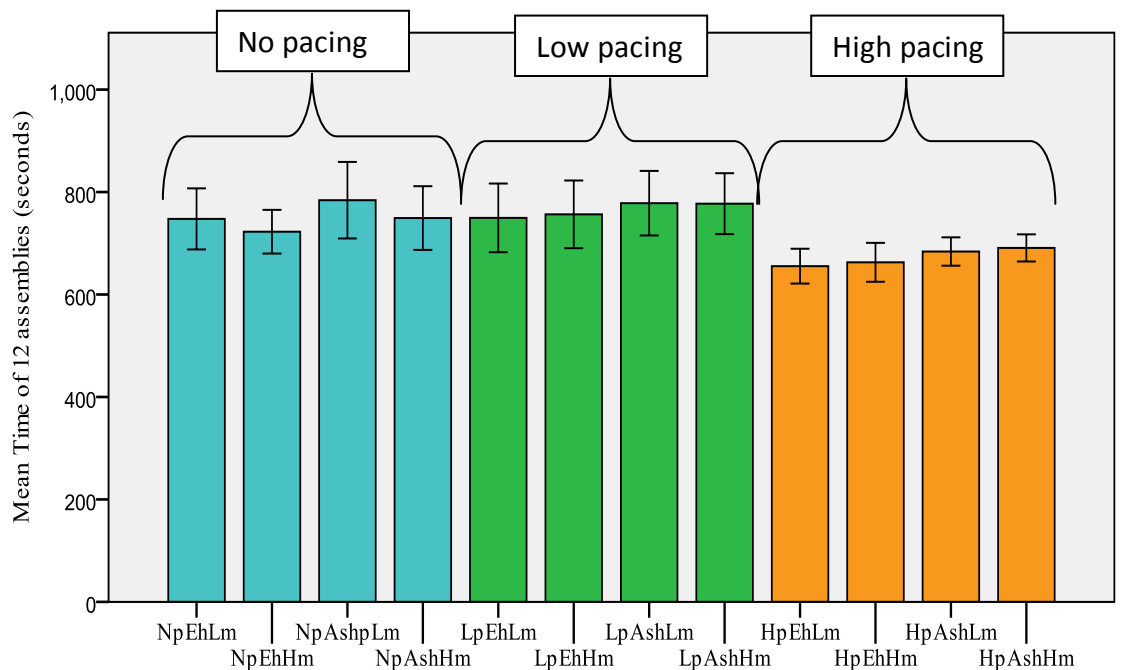

Figure 5-4: Mean and Standard error of assembly time for each of the 12 conditions

in assembly task

A three-way (3x2x2) repeated measures ANOVA was performed on assembly time. Mauchley's test for Sphericity confirmed that the assumption of homogeneity had been met. However, as the test for normality identified slight positive skew in one of the experimental conditions a square root of transformation was performed on the entire data set and the ANOVA was conducted on the transformed data. Significant effects on assembly time were found for pacing ($F=6.41$, $df=2,22$; $p<0.05$) and work height ($F=9.88$; $df=1,11$; $p<0.05$). Pair wise comparison of means using the Least Significant Difference test, showed that, as might be expected, performance time was significantly shorter at high pacing (673 seconds) than at either no pacing (750 seconds; mean difference = 76 seconds) or low pacing (765 seconds; mean difference = 92 seconds), but that there was no significant difference between the latter two. It was also found that participants took more time to perform the assembly task at above shoulder height (mean = 743 seconds) as compared to working at elbow height (mean = 711 seconds).

5.5.1.2 Number of correct code responses

It was hypothesised that cognitive demand such as memorizing the code during the assembly task may have significant effect on performance due to pacing, work height and memory load. A three-way (3x2x2) repeated measures ANOVA was performed on correct code responses. Mauchley's test for Sphericity confirmed that the assumption of homogeneity had been met. However, the test for normality identified negative skew on three experimental conditions (HP-EH-HM, NP-EH-HM and LP_ASH-LM) with $z>2.58$. Therefore, reciprocal ($k-x$) transformation was performed on the entire data set and the ANOVA was conducted on the transformed data. ANOVA showed no main effects (of pacing, work height or memory load) and interaction on the number of correct responses for the code memorised by the participant for each assembly were found to be significant. Table 5-4 and figure 5-5 show the mean (SD) of each condition on transformed data and error bars on real data respectively for number of correct code responses type after performing each assembly task.

No pacing				Low pacing				High pacing			
Elbow height		Above shoulder		Elbow height		Above shoulder		Elbow height		Above shoulder	
Low	High	Low	High	Low	High	Low	High	Low	High	Low	High
11.70	11.00	11.70	11.00	12.00	10.40	11.10	11.20	12.00	11.00	11.00	10.75
(0.65)	(1.44)	(0.49)	(1.00)	(0.79)	(1.78)	(1.38)	(0.83)	(0.80)	(1.64)	(0.94)	(1.86)

Table 5-4: Mean(SD) of each condition on correct code responses

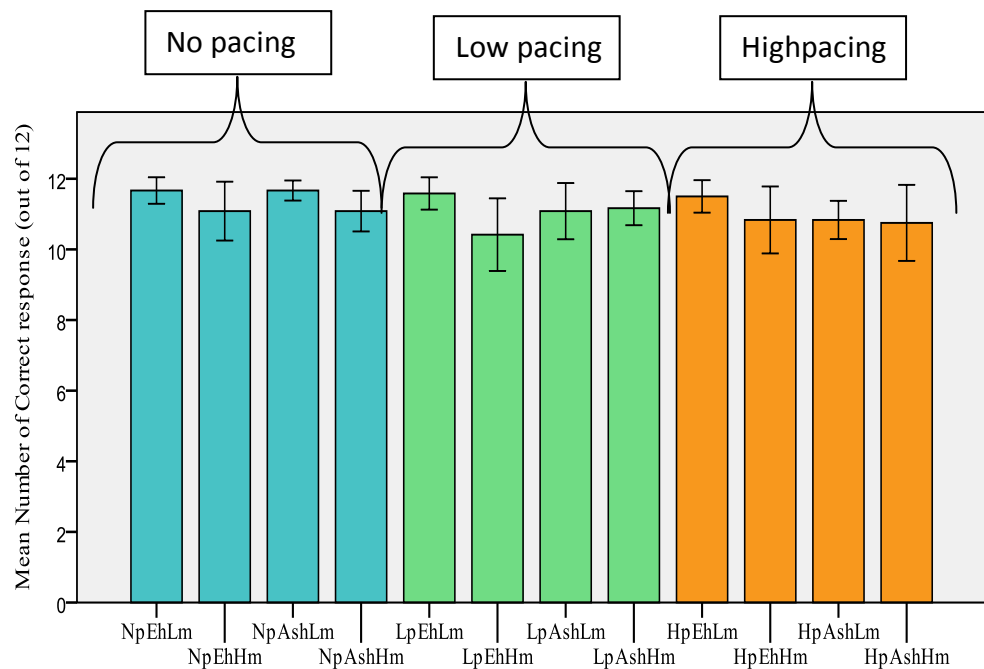

Figure 5-5 Mean (SE) of number of correct code responses of 12 conditions of assembly task.

5.5.1.3 Number of fully completed assemblies

A three-way (3x2x2) repeated measures ANOVA was performed on correct code responses. Mauchly's test for Sphericity confirmed that the assumption of homogeneity had been met. However, the test for normality identified negative skew on condition with $z > 2.58$. Therefore, ANOVA was performed on transformed data. Results showed pacing to have a significant effect ($F = 18.04$, $df = 2, 22$, $p < 0.05$) on the number of assemblies that were completed fully. Pair-wise comparison of means using Least Different Significant test showed that number of completed assemblies was lower at high pacing (60 assemblies) than at no pacing (67.1) and low pacing (69). Mean differences were 7.6 (between no pacing and high pacing) and 9.02 (between low pacing and high pacing). There was no significant difference between no pacing and low pacing.

Table 5-5 and figure 5-6 show the mean (standard deviation) of each condition collected on transformed data and bar graphs (standard error) on real data respectively.

No pacing				Low pacing				High pacing			
Elbow height		Above shoulder		Elbow height		Above shoulder		Elbow height		Above shoulder	
Low	High	Low	High	Low	High	Low	High	Low	High	Low	High
66.10	67.08	68.83	68.25	69.90	69.08	69.50	68.17	61.67	60.42	58.75	59.75
(6.33)	(9.55)	(5.02)	(6.14)	(4.81)	(4.60)	(3.94)	(6.28)	(10.16)	(9.38)	(11.14)	(8.75)

Table 5-5: Mean(SD) of each condition on number of fully completed assemblies

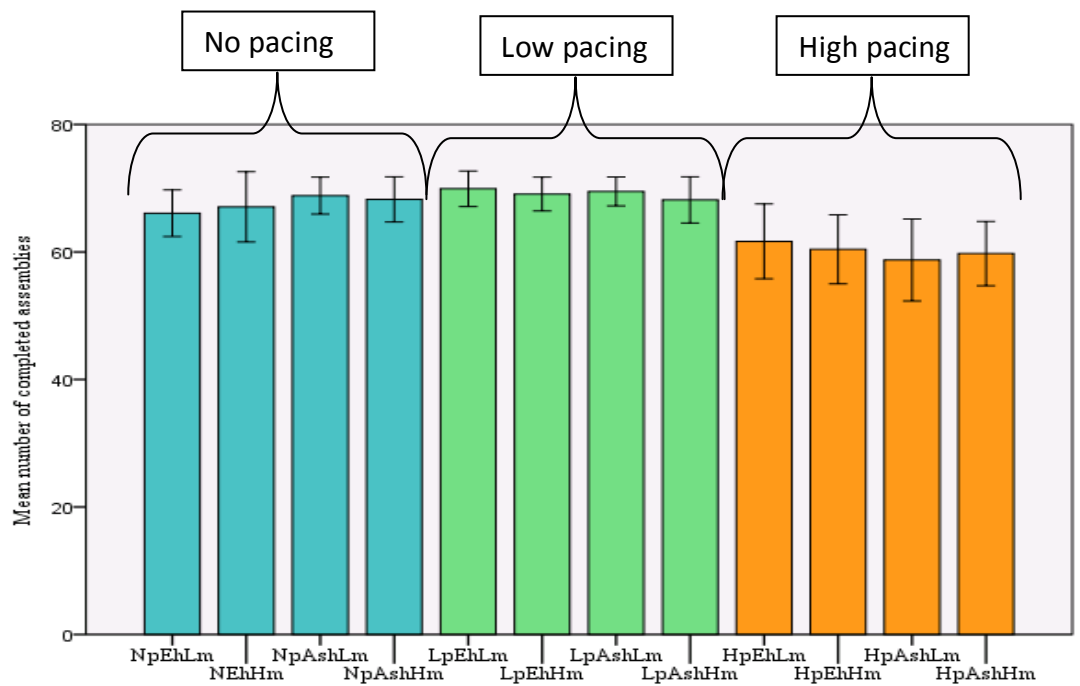

Figure 5-6: Mean (S.E) of number of completed assemblies of each of the 12 conditions in assembly task

5.5.1.4 Dropped nuts and bolts

It was predicted that there should be significant effects of number of dropped nuts and bolts on the levels of work height. The test for the Mauchly's assumption of sphericity was met. However, positive skew was found for the test of homogeneity, therefore, ANOVA was performed on transformed data. A three-way ANOVA showed the significant effect of pacing ($F=8.171$; $df=2,22$; $p<0.05$) and work height ($F=6.69$; $df=1,11$; $p<0.05$) on the number of dropped nuts and bolts. Pair wise comparison of means using least significant difference test showed that number of dropped nuts and bolts was higher at high pacing (2.9) than at no pacing (1.3) and low pacing (1.95). Mean differences were 0.95 (between no pacing and high pacing) and 1.52 (between low pacing and high pacing).

Pair wise comparison of means using Least Significant Different test also showed that the mean number of dropped nuts and bolts was higher above shoulder height (2.4) than at elbow height (1.8), mean difference = 0.569. However, the interaction was not significant.

No pacing				Low pacing				High pacing			
Elbow height		Above shoulder		Elbow height		Above shoulder		Elbow height		Above shoulder	
Low	High	Low	High	Low	High	Low	High	Low	High	Low	High
2.00 (1.28)	1.08 (1.78)	2.42 (1.88)	2.33 (1.50)	0.83 (0.94)	1.58 (1.83)	1.33 (1.37)	1.83 (1.53)	2.83 (2.33)	2.50 (1.73)	3.08 (2.47)	3.25 (2.99)

Table 5-6: Mean(SD) of each condition on number of number of dropped nuts and bolts

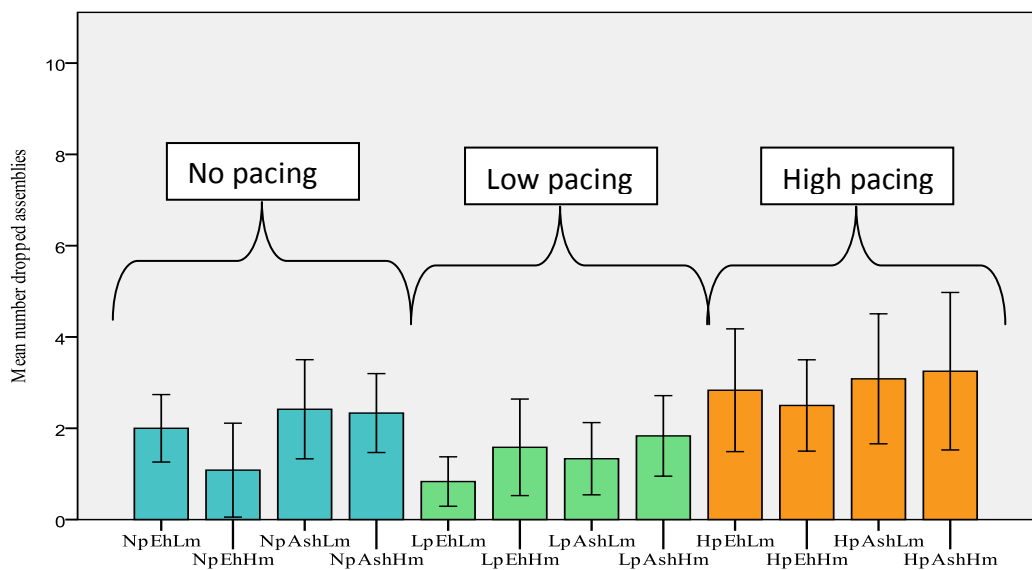

Figure 5-7: Mean (S.E) of dropped nuts and bolts in each condition of assembly task

5.5.1.5 Walking time

Walking time between assembly and the computer display was measured, as well as the time spent performing the assembly, to analyse any changes in behaviour in terms of partitioning time between the different parts of the task. A three way (3x2x2) ANOVA was performed on the walk time. Both the test for the Mauchly's assumption of sphericity and test for homogeneity had been met. A three-way ANOVA showed that there was a significant effect of pacing ($F = 10.519$, $df = 2, 22$, $p < 0.05$) on walking time. Pair wise comparison of means using Least Significant Different test showed that walk time between assembly and computer display was lower at high pacing (53.1 seconds) than at no pacing (60 seconds) and low pacing (59.1 seconds). Mean differences between no pacing and high pacing and between low pacing and high pacing were 8.1 seconds and 6.2 seconds respectively.

No pacing				Low pacing				High pacing			
Elbow height		Above shoulder		Elbow height		Above shoulder		Elbow height		Above shoulder	
Low	High	Low	High	Low	High	Low	High	Low	High	Low	High
61.10 (9.13)	60.83 (11.47)	60.75 (8.79)	61.08 (8.56)	58.60 (5.84)	57.83 (9.77)	60.67 (8.07)	60.58 (7.83)	52.25 (6.93)	52.33 (8.15)	55.00 (9.39)	52.67 (6.1)

Table 5-17: Mean(SD) of each condition on number of Walk time between assembly and computer display

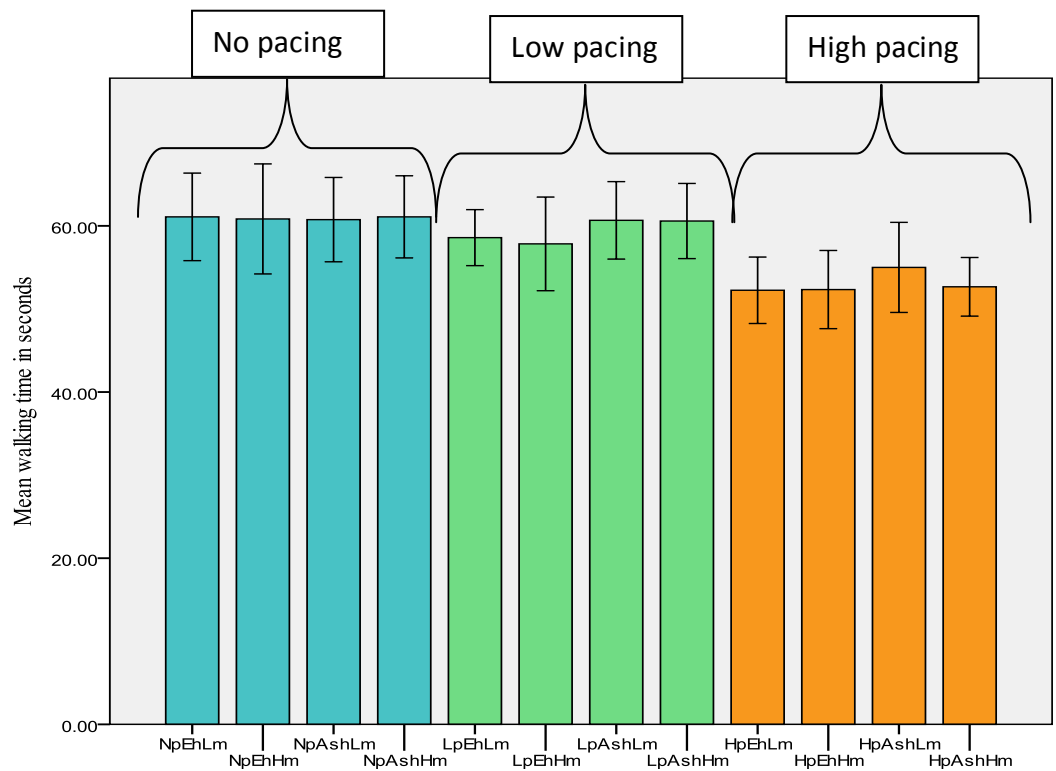

Figure 5-8: Mean walking time (in seconds) for each of the 12 conditions in assembly task

5.5.2 Subjective measures

Subjective responses were taken after each condition. The measures include dimensions of raw TLX, stress and arousal checklist, and physical well being checklist, which included ratings of fatigue and body part discomfort.

Test for assumption was carried out on the dimensions of NASA TLX.

Mauchley's test for Sphericity confirmed that the assumption of homogeneity and test for normality had been met for the demands of physical, mental, temporal and effort. However, as the test for normality for performance demand identified positive skew in one of the experimental conditions.

Therefore, logarithm of transformation was performed on the entire data set and the ANOVA was conducted on the transformed data.

Test of assumptions for stress and arousal score and fatigue responses were met for all the condition and the ANOVA was conducted on the real data.

Further sections discuss about the measurement of each dependent variable of subjective response.

5.5.2.1 NASA TLX ratings

Perceived work load was measured using dimensions of the NASA TLX subscales. Main effects of pacing, work height or memory load were found to be significant for all five of the measures and there was one interaction effect between pacing and work height on the perceived performance rating.

5.5.2.1.1 Perceived mental demand

The relevant hypothesis regarding the perceived mental demand states that different levels of each of the task pacing, work height and memory load would cause a significant difference in the response.

A three way (3x2x2) repeated measures ANOVA was conducted on perceived mental demands. ANOVA showed that there were significant differences due to the effects of work height ($F= 5.47$, $df= 1, 11$, $p<0.05$) and memory load ($F=9.0$, $df= 1, 11$, $p<0.05$), but that there was no significant effect of pacing.

Pair wise comparison of means using Least Significant Difference Test showed that mean ratings of raw NASA TLX for perceived mental demand (ranged from 0 as low and 20 as high) was higher at above shoulder height (6.4) than at elbow height (5.9), mean difference = 0.47. Pair wise comparisons of means also showed that mental demand was high at high memory load (6.97) than at low memory (5.9), mean difference = 1.67.

Table 5-8 and figure 5-9 further show the mean (SD) and bar graph (SE) for each condition of mental demand in the assembly task.

No pacing				Low pacing				High pacing			
Elbow height		Above shoulder		Elbow height		Above shoulder		Elbow height		Above shoulder	
Low	High	Low	High	Low	High	Low	High	Low	High	Low	High
4	6	6	7	5	6	4	7	6	8	6	8
2.71	3.26	3.25	3.32	3.10	4.20	2.39	4.35	3.06	3.73	2.66	3.36

Table 5-8: Mean (SD) of each condition of mental demand

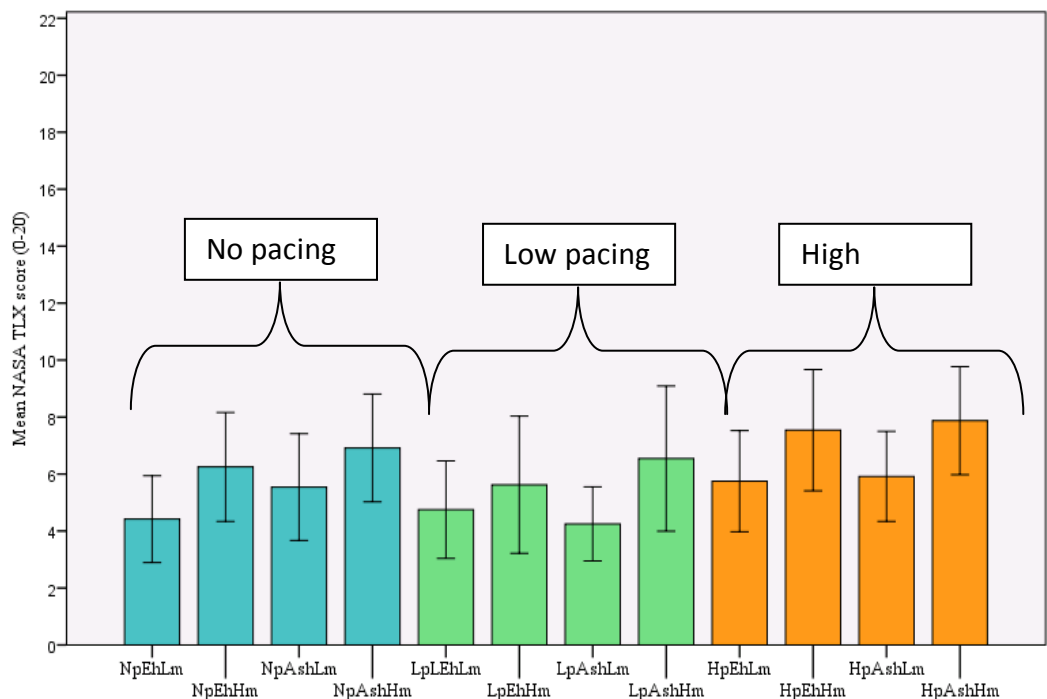

Figure 5-9: Means and standard errors of the perceived mental demand in the different task conditions of the assembly task

5.5.2.1.2 Perceived physical demand

A three way (3x2x2) repeated measures ANOVA showed that the only significant difference in perceived physical demand was due to the effect of work height (F= 31.70, df= 1, 11, p<0.05). Pair wise comparison of means using Least Significant Difference Test showed that mean ratings of raw NASA TLX for perceived physical demand (ranged from 0 as low and 20 as high) was high at above shoulder height (8.1) that at elbow height (6.1), mean difference = 2.63.

Table 5-9 and figure 5-10 further show the mean (SD) and error bar of each condition of perceived physical demand under three levels of pacing.

No pacing				Low pacing				High pacing			
Elbow height		Above shoulder		Elbow height		Above shoulder		Elbow height		Above shoulder	
Low	High	Low	High	Low	High	Low	High	Low	High	Low	High
5	5	9	8	5	5	8	7	8	8	9	9
2.93	3.08	4.08	4.01	4.01	4.42	4.66	5.09	4.36	4.20	4.34	3.29

Table 5-9: Mean (SD) of each condition of perceived physical demand

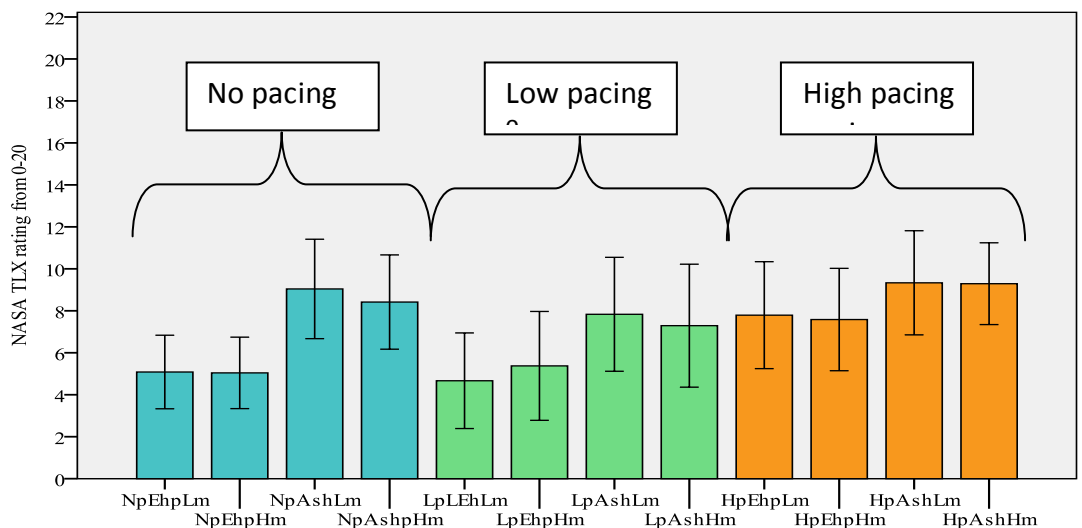

Figure: 5-10 Means and standard errors of the perceived physical demand in the different task conditions of the assembly task

5.5.2.1.3 Perceived Temporal demand

A three way (3x2x2) repeated measures ANOVA showed that there were significant differences in perceived temporal demand due to the effects of pacing ($F= 24.76$, $df= 2, 22$, $p<0.05$), work height ($F= 17.88$, $df= 1, 11$, $p<0.05$) and memory load ($F=5.56$, $df= 1, 11$, $p<0.05$). Pair wise comparison of means using Least Significant Difference Test showed that mean ratings of raw NASA TLX for perceived temporal demand (ranged from 0 as low and 20 as high) was high at high pacing (10.7) than at no pacing (4.35) and at low pacing (4.68). Mean differences were 6.37 (between no pacing and high pacing) and 6.04 (between low pacing and high pacing).

Pair wise comparison using Least Significant Different test also showed that perceived temporal demand was high at above shoulder height (7.11) than at elbow height (6.1) and perceived temporal demands was high at high memory (7). The mean (SD) and error bars for each of the 12 conditions are shown in table 5-10 and figure 5-11 respectively.

No pacing				Low pacing				High pacing			
Elbow height		Above shoulder		Elbow height		Above shoulder		Elbow height		Above shoulder	
Low	High	Low	High	Low	High	Low	High	Low	High	Low	High
4	4	4	5	4	5	5	6	10	10	11	12
(1.24)	(2.11)	(1.95)	(2.47)	5.07	3.85	3.53	5.16	4.35	3.60	3.09	3.06

Table 5-10: Mean (SD) of each condition of perceived physical demand

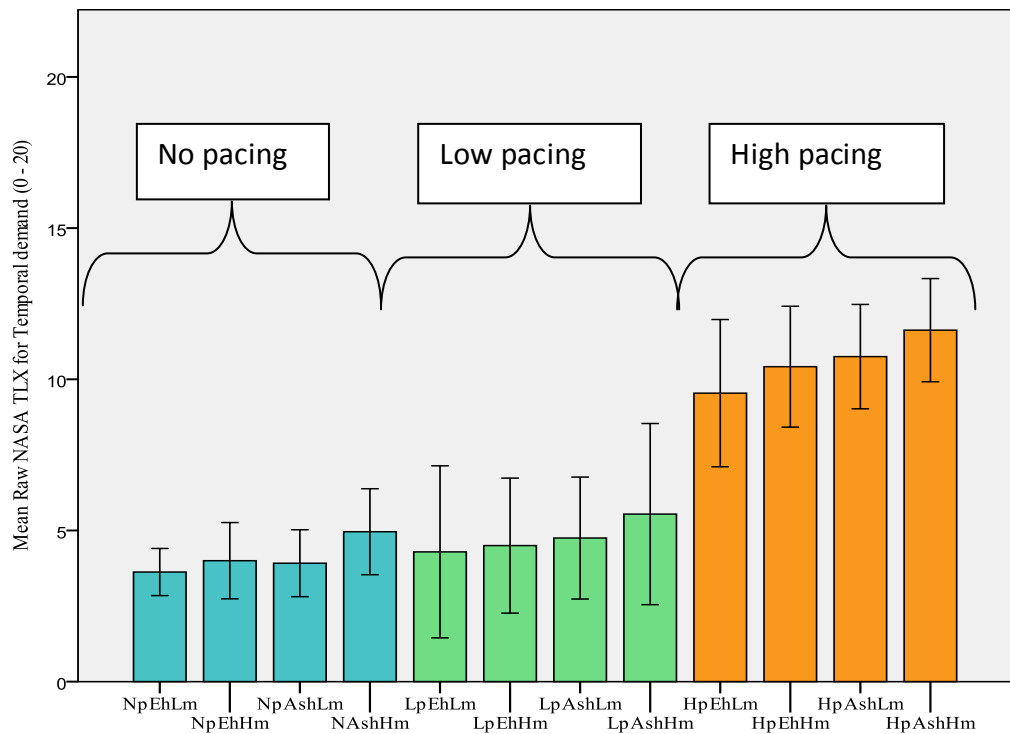

Figure 5-11: Means and standard errors of the perceived temporal demand in the different task conditions of the assembly task

5.5.2.1.4 Perceived performance

A three way (3x2x2) repeated measures ANOVA was performed on transformed in order to meet the assumption of normality. ANOVA showed that there were significant differences in perceived performance due to the effects of pacing ($F= 10.72$, $df= 2, 22$, $p<0.05$). Pair wise comparison of means using Least Significant Difference test showed that the perceived performance (0 as perfect and 20 as failure) was lower at high pacing (5.9) than at no pacing (3.9) and low pacing (3.5). Mean differences were 1.95 (between no pacing and high pacing) and 2.37 (between low pacing and high pacing).

A significant interaction was also found between the pacing and work height ($F= 4.39$, $df=2,22$, $p<0.05$). Pair wise comparison using Least Significant Different test showed that the perceived performance was better at high pacing + elbow height (5.04) as compared to the perceived performance at high pacing + above shoulder height (6.7). Mean(SD) and error bars of perceived performance for each of the 12 conditions in assembly tasks are shown in table 5-11 and figure 5-12 respectively.

No pacing				Low pacing				High pacing			
Elbow height		Above shoulder		Elbow height		Above shoulder		Elbow height		Above shoulder	
Low	High	Low	High	Low	High	Low	High	Low	High	Low	High
4	4	4	5	4	5	5	6	10	10	11	12
1.24	2.11	1.95	2.47	5.07	3.85	3.53	5.16	4.35	3.60	3.09	3.06

Table 5-11: Mean (SD) of perceived performance for each of the 12 conditions in assembly task.

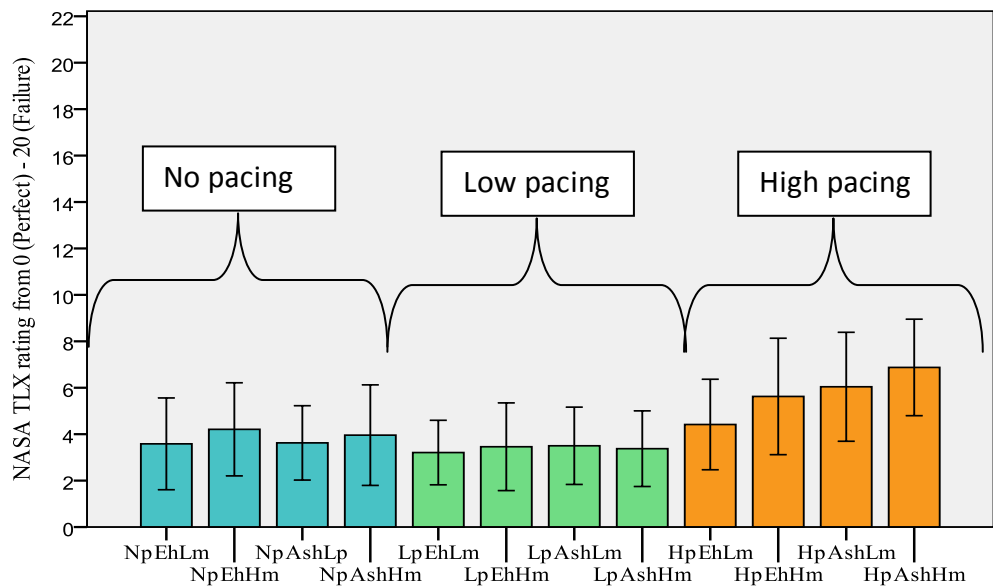

Figure 5-12: Mean and S.E of perceived performance for each of the 12 conditions in assembly tasks

5.5.2.1.5 Perceived Effort

A three way (3x2x2) repeated measures ANOVA was performed on the real data. ANOVA showed that there were significant differences in perceived effort due to the effects of pacing ($F= 7.0$, $df= 2, 22$, $p<0.05$), work height ($F= 11.74$, $df=1, 11$, $p<0.05$) and memory load ($F=5.5$, $df= 1, 11$, $p<0.05$). Pair wise comparisons of means using Least Significant Difference test showed that mean ratings of perceived effort (0 as low and 20 as high) was high at high pacing (10.66) than at no pacing (8.12) and low pacing (7.25). Mean differences were 2.5 (between high pacing and no pacing) and 3.41 (between low pacing and high pacing).

ANOVA also showed that perceived effort was high at above shoulder height (9.36) than at elbow height (8). Perceived effort was found to be high at high memory load (9.06) than at low memory load (8.29). The overall mean (SD) and error bars for perceived effort are shown in table 5-12 and figure 5-13 respectively.

No pacing				Low pacing				High pacing			
Elbow height		Above shoulder		Elbow height		Above shoulder		Elbow height		Above shoulder	
Low	High	Low	High	Low	High	Low	High	Low	High	Low	High
7	7	9	9	6	7	7	8	10	10	11	12
3.91	3.58	4.48	4.57	4.39	4.01	3.75	5.21	4.89	3.94	3.87	3.07

Figure 5-12: Mean and SD of perceived Effort for each of the 12 conditions in assembly tasks

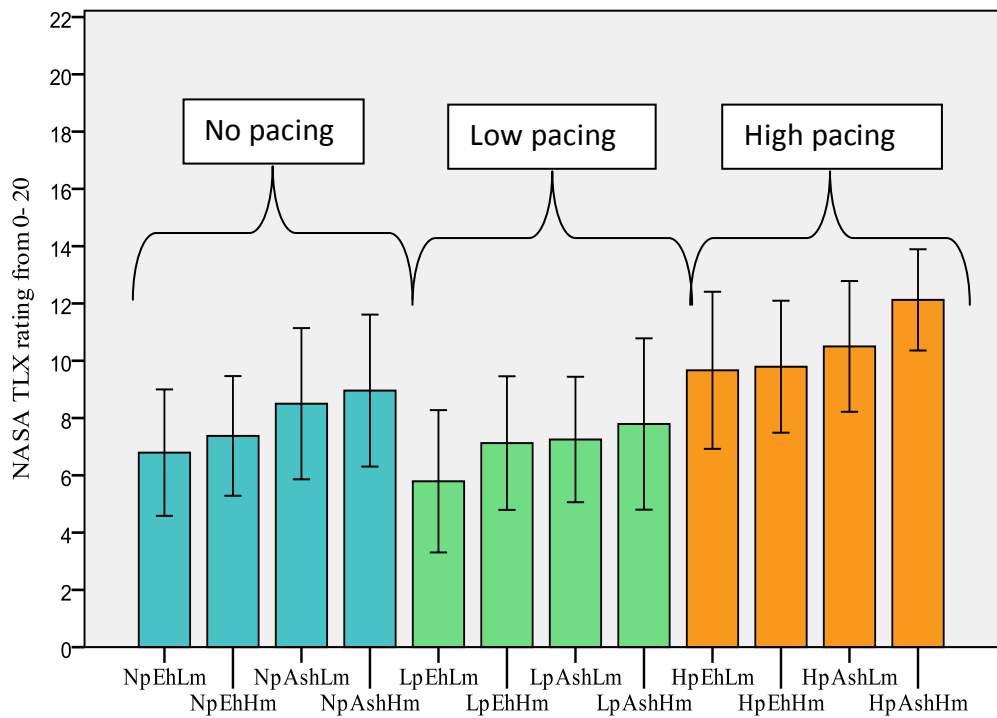

Figure 5-13: Mean and S.E of perceived Effort for each of the 12 conditions in assembly tasks

5.5.2.1.6 Fatigue rating

Perceived fatigue using the physical well being checklist was measured after each condition. The rating scale was 0 as extremely energetic and 10 as extremely tired or fatigued. Mauchly's test for Sphericity confirmed that the assumption of homogeneity and test for normality had been met for the fatigue. A three way (3x2x2) ANOVA was performed on fatigue to analyse the effects of three levels of pacing, two levels of posture and two levels of memory and also to determine there was any interaction. However, ANOVA showed no significant effects of pacing, work height or memory load (or of their interactions) were found for the fatigue rating. Table 5-13 shows mean and standard deviation for each condition of fatigue.

No pacing				Low pacing				High pacing			
Elbow height		Above shoulder		Elbow height		Above shoulder		Elbow height		Above shoulder	
Low	High	Low	High	Low	High	Low	High	Low	High	Low	High
7	7	9	9	6	7	7	8	10	10	11	12
3.91	3.58	4.48	4.57	4.39	4.01	3.75	5.21	4.89	3.94	3.87	3.07

Table 5-13: Mean and SD of perceived Fatigue for each of the 12 conditions in assembly tasks

5.5.2.2 Stress and arousal scores

No significant effects of pacing, work height or memory load (or of their interactions) were found for stress score. However, the repeated measures ANOVA showed a significant effect of pacing ($F = 5.457$, $df = 2, 22$, $p < 0.05$) for arousal score. Pair wise comparison of means using Least Significant Difference test showed that the arousal score was higher with no pacing (28.3) or high pacing (27.3) than in low pacing conditions (25.1). Mean difference between no pacing and low pacing was 2.83) and between high pacing and low pacing was 2.0. Table 5-14 and 5-15 further show the mean (SD) of each condition of perceived stress and arousal score in assembly task respectively.

No pacing				Low pacing				High pacing			
Elbow height		Above shoulder		Elbow height		Above shoulder		Elbow height		Above shoulder	
Low	High	Low	High	Low	High	Low	High	Low	High	Low	High
32	28	31	30	31	32	34	34	33	33	34	33
8.37	7.13	8.24	8.53	8.76	10.28	9.99	10.39	9.25	10.71	11.07	9.25

Table 5-14: Mean and standard deviation for each condition of Stress score in assembly task

No pacing				Low pacing				High pacing			
Elbow height		Above shoulder		Elbow height		Above shoulder		Elbow height		Above shoulder	
Low	High	Low	High	Low	High	Low	High	Low	High	Low	High
27	30	28	29	25	26	26	25	27	27	27	28
5.69	4.94	4.85	4.00	6.63	5.69	4.83	6.27	4.78	6.43	5.79	2.55

Table 5-15: Mean and standard deviation for each condition of Arousal score in assembly task

5.6 Main findings of Study 1

Study 1 was conducted to examine the performance and subjective outcomes of pacing, mental demand and physical demand using the experimental set up described in Chapter 4. In some ways, the first study was a test of the experimental design and participants demonstrated smooth flow on the assemblies and that they could understand all tasks and procedures.

The results also showed significant effects that are discussed below as main findings of the study. Table 5-18 and 5-19 show the summary results of objective and subjective measures respectively.

- Time of assembly task (especially high pacing/ high Takt time) affects the quality of performance. As not all the participants could finish the assembly task in time due to high Takt time and the number of fully fastened assembly was also found to be little lower under high pacing/ Takt as compared to the no pacing and low pacing. Participants also moved more speedily between assembly task and computer display during high pacing.
- Work height levels also affected the performance as the time to complete the assembly task and the number dropped nuts and bolts were higher at above shoulder height.
- Time to complete the assembly task affected the perceived raw TLX dimensions. Perceived temporal demand and perceived effort were higher during high pacing, and perceived performance was also found to be bad at high pacing/ Takt.
- Raw TLX dimension were also affected by work height levels. An interesting finding was that the perceived mental demand was higher at the above shoulder height, which produced some sort of interaction between physical and mental demand. Furthermore, perceived physical demand, temporal demand and effort were also found to be higher at above shoulder height.

- Perceived mental demand and temporal demand were affected by high memory load (memorising the six digits code).
- There was only one interaction found between pacing and work height for perceived performance, which could be expected as the perceived performance was found to be worse at high pacing + above shoulder height as compared to the perceived performance at high pacing+ elbow height.

These findings are further discussed in next section for detail understanding about the current study.

Independent variable	Dependent variable				
	Assembly time	Number of correct code responses	Number of fully completed assemblies	Walking time	Number of dropped nuts and bolts
Pacing df (2,22)	F=6.42* LP& NP >HP	F=1.233	F=18.04** LP& NP >HP	F=10.519* LP&NP> HP	F=8.171
Work height df (1,11)	F=9.89** ASH>EH	F=0.899	F=0.074	F=2.07	F=6.69** ASH>EH
Memory df (1,11)	F=0.490	F=4.082	F=0.677	F=0.452	F=0.105
Pacing X Work height df (2,22)	F=0.119	F=0.569	F=2.672	F=1.36	F=0.777
Pacing X Memory df (2,22)	F=1.74	F=0.599	F=2.321	F=0.553	F=1.88
Work height X Memory df (1,11)	F=0.573	F=2.29	F=0.005	F=0.094	F=4.496
Pacing X Work height X Memory df (2,22)	F=0.093	F=2.59	F=3.013	F=0.684	F=1.10

Table 5-17: Results of analysis of variance for the objective measures (with significant effects indicated in bold)

* p <0.05, ** p<0.01

NP - No pacing, LP - Low pacing, HP - High pacing, ASH - Above shoulder height, EH - Elbow height, LM - Low memory load, HM -High memory load

Independent variable	Dependent variable							
	NASA TLX					PWC	Stress & Arousal scores	
	Mental demand	Physical demand	Temporal demand	Performance	Effort	Fatigue	Stress	Arousal
Pacing df (2,22)	F=1.858	F=3.19	F=24.76** LP& NP >HP	F=10.75** LP&NP<HP	F=7.00* HP>LP&NP	F=0.330	F=3.29	F=5.752* NP>LP&HP
Work height df (1,11)	F=5.472* ASH>EH	F=31.70** ASH>EH	F=17.88** AS>EH	F=2.68	F=11.743** ASH>EH	F=4.58	F=1.56	F=0.265
Memory df (1,11)	F=9.00* HM>LM	F=0.108	F=5.56* HM>LM	F= 2.38	F=5.21* HM>LM	F=0.021	F=0.40	F=1.370
Pacing X Work height df (2,22)	F=0.561	F=2.027	F=0.485	F=4.39* HP+ASH>HP+EH†	F=0.26	F=0.751	F=0.69	F=0.08
Pacing X Memory load df (2,22)	F=0.036	F=0.215	F=0.137	F=1.87	F=0.149	F=0.376	F=2.25	F=1.75
Work height X Memory df (1,11)	F=0.164	F=1.375	F=0.079	F=0.233	F=0.127	F=2.20	F=0.23	F=1.46
Pacing X Work height X Memory df (2,22)	F= 1.150	F=0.63	F=0.878	F=0.332	F=1.453	F=1.376	F=0.35	F=0.313

Table 5-18 Results of analysis of variance for the subjective measures* p <0.05, ** p<0.01

*NP - No pacing, LP - Low pacing, HP - High pacing, ASH - Above shoulder height, EH - Elbow height, LM - Low memory load, HM - High memory load

† Note: This indicates that the rating for performance at LP+ASH is worse than that for LP+EH because the NASA TLX performance rating scale is 0 - Perfect to 20 - Failure.

5.7 Discussion of Experiment 1

The study investigated the effects of pacing, work height and memory load on quality of performance and time spent on the different activities within the task cycle (specifically assembly and walking around the workstation).

Subjective responses were also collected after each condition using NASA TLX to measure dimensions of the work load, and the Stress and Arousal checklist to measure the stress and arousal levels, as well as a physical well being checklist to measure fatigue and discomfort.

As can be seen from the results in Tables 5-17 and 5-18 above, pacing, work height and memory demands all had an effect on some of the measures of performance and workload perceptions. The work height effects on assembly time, perceived physical demands and perceived effort were those that would be expected from consideration of ergonomic workstation design (Grandjean and Kroemer, 1998).

The effects of memory load were also as expected, specifically shown by the perceptions of mental demand, temporal demand and effort. Memory load was not found to have an effect on any of the objective measures of performance, although this does not rule out a possible effect if greater memory load were demanded than the 4 digit and 6 digit recalls that were imposed in this experiment.

More interesting is the evidence of the complex ways in which the level of pacing can affect aspects of behaviour, such as the change in proportion of the cycle time spent on the assembly task in relation to the intervening times walking between different parts of the workstation or the quality of the work as measured by numbers of assemblies that were not fully (or adequately) completed. These changes in behaviour reflect the participants' decisions in making various trade-offs between quality and speed of work and also show how pressure is felt by the need to maximise the time spent assembling at the expense of rushing the less productive parts of the task cycle (in this case walking).

The subjective response measures also showed that pacing resulted in perceptions of greater mental demand, temporal demand, performance and effort, and increased arousal. It should also be noted that the various effects were not simply due to pacing being imposed. The post hoc tests did not find a significant difference in any measure between the no pacing and the low pacing (90s cycle time) conditions. It was the more rapid work rate imposed by the high pacing 60 seconds cycle time that affected both behaviour and participants' perceptions.

The fact that work height had a significant effect on perception of mental demand is also surprising and relevant. Further experiments will be necessary to understand these effects more clearly but the results do emphasise the need to consider the potential complex interactions between aspects of the task and the consequences of imposing pacing and deadlines on production line tasks while maintaining the quality of the work and the well-being of the workers.

When no pacing was imposed and the participants could perform the assemblies at their own speed, all the assemblies were completed fully (with nut and bolt assemblies finger tight) and the codes were memorised and typed accurately. The higher pacing, set at 60 seconds to finish each assembly, clearly caused more difficulty and some participants were unable to finish all their assemblies in the required time. The quality of performance also deteriorated, with increases in the number of poorly completed assemblies, incorrect responses, and numbers of dropped nuts and bolts. These results were similar to those found in previous studies conducted (Escorpizo and Moore, 2007, Dempsey et al., 2010, Bosch et al., 2011). The stress score was not affected significantly by pacing, work height or memory load, which is similar to the finding in a study by Poolton et al. (2011).

The above discussion of the results of study 1 demonstrate the significant effects of levels of pacing, working height and memory load on the quality of performance and subjective responses, aiming to test the hypotheses that the

selected independent variables may have significant effects on dependent variables. From a theoretical perspective, Armstrong's dose-capacity model may explain the results obtained with regard to the effects of physical demands on the performance. . Work height (exposure) as an independent variable with the level of above shoulder acted as a dose that caused disturbance and eventually resulted in an impact upon the capacity of performance. These responses were also found to be psychosocial (assembly time and number of fully fastened assemblies due to short Takt/ high pacing) physical (increased physical demand and effort due to working at above shoulder height) and psychological (increased mental demand due to work height). This demonstrates a link between dose and performance on both physical and psychological outcomes as suggested by the Armstrong model.

With regard to Wicken's MRM model, as the task involved simultaneous performance of physical (Work height and fastening of nuts and bolts) and multiple cognitive (memorising the code and Takt time) demands. The objective was to examine the theoretical understanding on how and what resources are used to perceive, interpret and execute the visuo-spatial task, and to know the interference occurred during the simultaneous performance of cognitive tasks. The experimental study was however, found to be not as demanding as expected as the participants were able to memorise the code during the simultaneous performance of fastening nuts and bolts at required height. This on the other hand could be explained by the Wickens MRM because the two cognitive tasks used different resources (Wicken's 2002 and 2008). However, there is another explanation that memorising the code and assembly were using the same resources, but the load of even the 6 digit code was so low that this did not cause as problem for the operator. To test this, the experimental study should be modified to be more cognitively demanding in order to analyse the theoretical understanding on resources used during perceptual stages and resources used during selection and execution of task. Increased cognitive demands were therefore tested in study 2 by making the assembly more demanding, and increasing the length of the code.

5.8 Summary

It was concluded that the type of assembly line pacing commonly used (simulating the application of a Takt time system) can significantly affect aspects of performance, behaviour and perceived workload and stress. Physical demands (through work height affecting posture) and cognitive demand (through memory load) were also found to have significant effects on performance and/or subjective measures, as would be expected from the many studies of these which have been reported in the literature. However, the possibility of interactions between organisational, physical and cognitive aspects of industrial assembly work has been little studied previously. So finding that such an interaction can occur is particularly interesting, as is the fact that it influenced the quality of the assembly work.

Some main effects were found for work height and pacing. However, the results of study 1 revealed few effects, particularly in terms of cognitive demand, that suggest it was not sufficiently demanding to be sensitive to differences between some conditions specifically. Limitations of the study 1 were the code size was easy to remember and assembly task was quite simple. Overall study 1 was found to be less demanding and there a need to modify the variables in order to investigate the effects of physical and cognitive demands in more detail. Chapter 6 discusses in detail the design and results of study 2.

6 Study 2 - Investigation of the effects of assembly order (Variable assembly and consistent assembly) in relation to cognitive and physical demands

6.1 Introduction

Chapter 5 described Study 1, which showed that the levels of pacing in an assembly task could significantly affect aspects of both performance and perceived workload and stress. An interaction between physical and cognitive demands was also found, which further needed to be understood in detail. However, the effects found were relatively small, possibly due to the level of memory load in the task not being sufficiently high. This chapter describes study 2, which added a new cognitive aspect to the task and increased the memory load with the aim that study 2 would give more comprehensive analysis of the interaction between physical and cognitive demands.

Study 1 was designed by incorporating the aspects of physical and cognitive demands based on real observation and previous literature. It was assumed that the effects of physical and cognitive demands would affect the objective and subjective measures and also cause interaction between physical and cognitive demands. The results of study 1 showed main significant effects and also showed some significant interactions. However, the results showed ceiling effects and the overall effects of physical and cognitive demands on the objective and subjective measures were not high and generally study 1 was not found to be physically and cognitively demanding. There were also limitations in the study, that might have contributed to this including it being a simple assembly task, and code size for low and high memory was easy to memorise. In both conditions the code length was less than seven digits, which is considered to be approximately point at which short term memory typically reaches capacity (Miller, 1956; Baddeley, 1994).

Considering the effects and limitations, study 2 was designed by modifying study 1 to be more demanding. The cognitive demand was modified by increasing the size of memory code for both conditions, with the high demand

condition requiring recall of an eight digit code. The present study also compared the effects of pacing for working at a single model assembly task (simulating the situation in which only one model of a product is being processed through a workstation of a paced assembly line) with working at a mixed model assembly task (with several models being processed in the same assembly line). This was a mode of working observed at production lines observed during the field visits described in Chapter 3, and has been identified as potentially more demanding (Sood et al., 2007) .

It was predicted that there would be differences in various performance measures, both subjective and objective, between the single and mixed model assembly tasks, because of the demands of more cognitively complex work in the mixed model task.

Also, in order to reduce the effects of participants being new to the task, and to try and replicate operators on real production lines are both familiar and skilled at their assembly tasks, the decision was made to use the same participants that had already taken part in Study 1. This also supported a direct comparison of the results from Study 1 with Study 2.

6.2 Task Analysis

Study 1 was designed in part to see the sequential flow and task performance of the simple, simulated assembly task. Results showed significant effects of pacing, work height and memory load on the performance and subjective responses. However, as discussed above, the effects were limited.

Therefore, study 2 was designed with more complexity by manipulating the assembly task and code memory made more cognitively demanding. Figure 6-1 shows the hierarchical task analysis of study 2 with the modification of assembly task into consistent assembly and variable assembly order as mentioned in the grey box activity 3.2. The detailed description about the procedure of the task is discussed in the next sections.

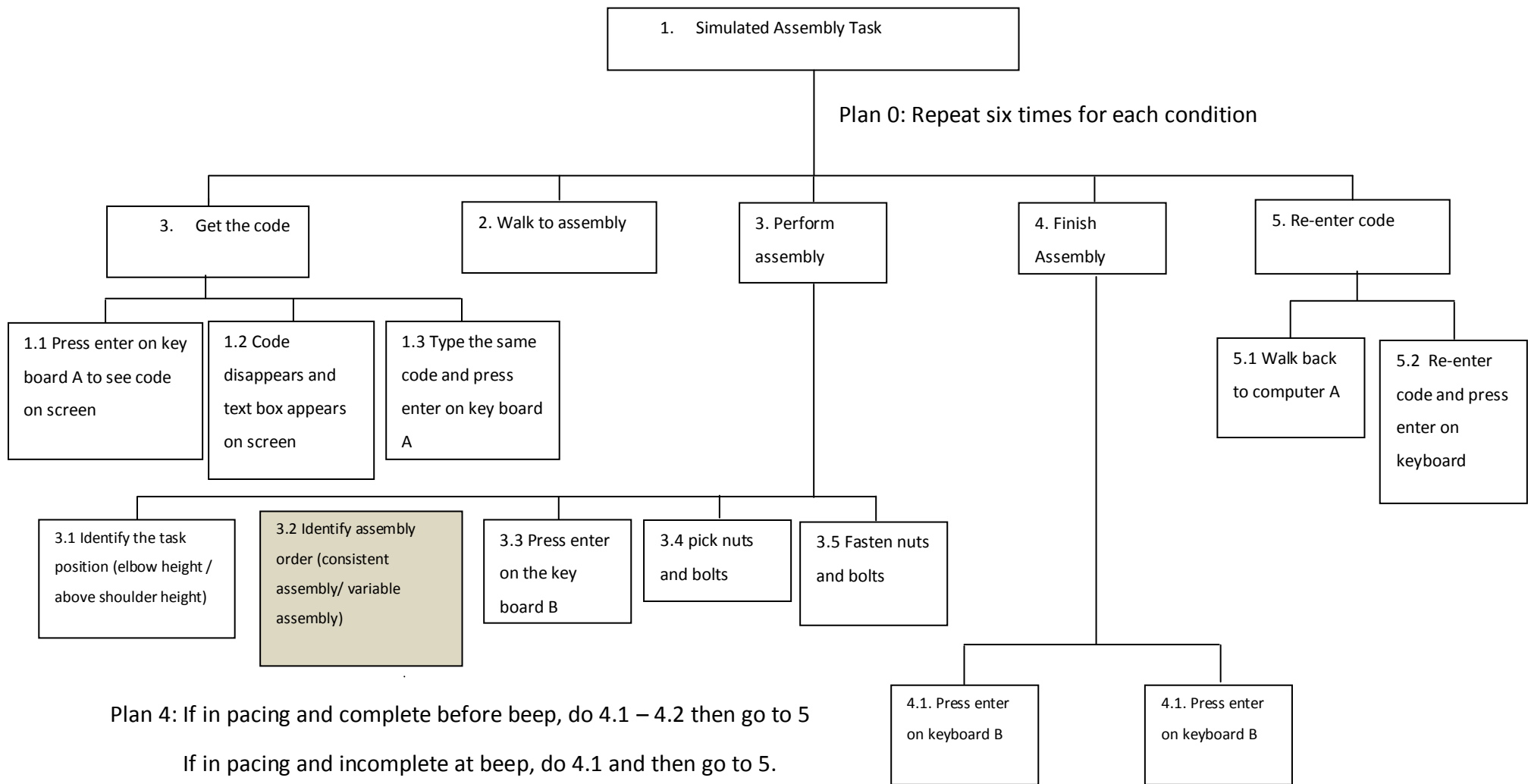

Figure 6-1: Hierarchical task analysis for the simulated assembly task for experiment 2

6.3 Experimental design

6.3.1 Participants

Not all participants from study 1 could take part in study 2. Therefore, nine participants (4 males and 5 females) with the mean age of 27.6 years (SD 3.4 years), were recruited from the university. All participants signed the consent form approved by the local ethics approval committee. All the participants had taken part in the Study 1 and so were familiar with performing the required assembly task.

6.3.2 Independent Variables

Three independent variables were considered: time demand, physical demand and cognitive load. The time demand resulted from pacing with low pacing set at a completion (Takt) time of 90 seconds for each assembly and high pacing with a completion time of 60 seconds per assembly, as in Study 1. The physical demand was also created by the same two levels of work height (elbow height and above shoulder height with upper arm parallel to the ground) as in Study1. The cognitive load however changed from that in Study 1. Firstly the memory load was increased from memorising the 4- or 6-digit product code of Experiment 1 to memorising an 8-digit product code. Secondly, the assembly had to be completed either in a consistent order (in which the components were assembled in the same order for all repetitions of the task cycle) or in an order that varied between task cycles. Figures 6-2 (a) and (b) show the layout varied between the consistent and variable assembly order conditions.

6.3.3 Presentation of assembly order

As discussed above that the assembly task was changed to represent a mixed model assembly line, which is designed as a metallic plate with six holes, each randomly numbered as shown in figure 6-2. The random numbering order from 1 to 6 in all the metallic plates in a row of six assembly tasks showed the variation in each task of the assembly line that represented mixed model assembly line.

Figure 6-2 (b) shows the representation of single model assembly line, in which all the six holes in each metallic plate are numbered in sequence order of 1 to 6 (Top shows odd numbers and bottom shows even numbers). All the metallic plates in a row of six assembly tasks are arranged in a same sequence order.

Underneath each assembly, a bin with six trays was attached as shown in figure 6-2 (a). The trays were numbered in a sequence order from 1 to 6 (odd numbers at left and even numbers at right). The bolts were also numbered from 1 to 6 on their top and placed in plenty in their relevant trays. At the right of bin, another tray was attached that contained a supply of wing nuts.



(a) Code matching in the assembly task in variable order



(b) Code matching in the assembly task in consistent order

Figure 6-2: Presentation of Assembly order

6.3.4 Dependent Variables

The same objective and subjective performance measures were recorded as in Study 1. The objective measures were time to complete the assembly task, number of assemblies fully completed, number of correct code recall responses, time spent walking between computer and assembly, and number of nuts and bolts dropped. Subjective measures were used for mental workload, using Raw NASA TLX (Hart and Stavenland, 1988, Moroney et al., 1992), stress and arousal score, using the stress and arousal checklist (Cox, 1985) and fatigue and discomfort using physical well being checklists.

6.3.5 Procedure

The experiment lasted for 2 hours 30 minutes for each participant. The experiment consisted of 8 conditions (four conditions under low pacing and four conditions under high pacing). The conditions were performed within subjects as each participant performed all the conditions in random order. There was a 5 minute break between conditions. During the break, the participant completed the subjective responses. The experimental sequence is shown in Figure 6-3.

In this study, the number of task cycles was reduced from 12 (in study 1) to 6. This was due to no difference was found between two similar conditions in experiment 1. In each condition the participant performed six repetitions of the assembly task. The task was to attach six nuts and bolts to a plate, in a given order that was identified on the plate (as shown by the labels on the plates in Figure 6-1 (a) and (b) above). The participants were instructed to pick the bolts in the order to 1 to six and fasten at the relevant number. The experiment was performed standing. Before each assembly, the participant was asked to read the 8-digit code for the particular product to be assembled from a computer display and memorise this. The code had to be typed immediately and then again after completing the assembly. The full task therefore involved walking between the computer and the assembly station, simulating the movements around the different areas of a production assembly cell.

6.3.6 Instructions to the participants

Following documentation and verbal instructions were given to the participants before starting the experiment.

- First of all, anthropometric data were taken from each participant, which included total height, elbow height and shoulder height. This measurement was used to adjust the assembly task at elbow height and above shoulder height for each participant. Simple meter scale was used to measure the heights of each participant.
- Participant was then seated and was given instruction sheet to read. The instruction sheet described the whole experiment in detail.
- After going through instructions, the participant was given physical well being questionnaire.
- In the end the participant was given the consent form, which showed that the participant fully agreed to take part in the experiment and he/she did not have any underlying health problem.
- After going through the documentation, the participant was shown the experimental setup and verbal instructions were given about the start and finishing the experiment. After giving the verbal instruction, the participant was given the 5 minutes practice session in order to completely familiar with the task.
- The participant was asked to start the task from the computer display, where he had to press ENTER key on the key board. Display showed the code, which participant had to memorize. The code disappeared after few seconds and another window opened where the participant had to enter the same code. After entering the code the participant was asked to press the ENTER key and walk to assembly section. However, the participant was instructed to memorize the code during the assembly task.
- At the assembly, the participant was asked to press the RED KEY on the key board (lying at the assembly section) before and after performing the assembly operation. Participant was instructed to start

the assembly just after pressing the RED key and press the same key just after finishing the assembly. All the participants started the assembly task of picking and fastening nuts and bolts from right side of the assembly row, which consisted of 6 assembly tasks.

- After finishing the assembly the participant was asked to move back to the computer display, where he/she had to enter the code and press Enter for getting another code for the next assembly and so on.
- During low and high pacing conditions the participant was asked to wait at assembly area, if the assembly task was finished before time. The participant walked back to computer display as he /she heard a beep.

6.3.7 Test for Assumptions

Each dependent variable was tested to check whether the assumptions for Analysis of Variance (ANOVA) had been met. For all of the analyses reported in this chapter, Mauchly's test confirmed that the assumption of sphericity had been met and tests for normality using z-skew showed $z < 1.96$ for each experimental condition. Therefore, the ANOVA was conducted on the raw data collected through objective measures and subjective responses. Pair wise comparison of means using the Least Significant Difference test was carried out to conduct the post hoc analysis. The results of each dependant variable are further discussed in their relevant sections.

6.4 Results

A 3-way (2x2x2) repeated measures analysis of variance (ANOVA) was conducted to investigate the effects of pacing, work height and assembly order (variable assembly and consistent assembly order) in relation to physical and cognitive demands on the performance and subjective responses. The data was analysed using univariate test for within subjects and pair wise comparison was carried out to conduct the post hoc analysis. However, the measures of discomfort have not been included in the summary table, because no significant effects were found.

6.4.1 Objective measures

6.4.1.1 Assembly Time

A three way (2x2x2) repeated measure ANOVA showed significant differences in assembly time between the two levels of pacing ($F=126.46$, $df= 1, 9$, $p<0.001$), the two levels of work height ($F= 12.83$, $df= 1,8$, $p<0.001$) and the two levels of assembly order ($F= 7.52$, $DF= 1,8$, $p<0.05$). Pair wise comparison of means using Least Significant Difference test showed that assembly time low at high pacing (350 seconds) that at low pacing (394 seconds), which meant that not all the participant could finish their assembly task under high pacing conditions. Moreover, results also showed that assembly time was high at above shoulder height (377 seconds) than at elbow height (367 seconds). Mean assembly times for assembly order was also found to be high at variable assembly than at consistent assembly. The mean(SD) and errors bars of assembly time for each of the 8 conditions in assembly task are shown in table 6-1 and figure 6-4 respectively.

Low pacing				High pacing			
Elbow height		Above shoulder		Elbow height		Above shoulder	
Variable assembly	Consistent assembly	Variable assembly	Consistent assembly	Variable assembly	Consistent assembly	Variable assembly	Consistent assembly
394.33 (10.50)	383.22 (24.08)	409.44 (18.44)	387.89 (22.59)	348.33 (11.78)	341.89 (18.57)	358.22 (11.04)	352.22 (11.83)

Table 6-1: Mean (SD) of assembly time for each of the 8 conditions in assembly task

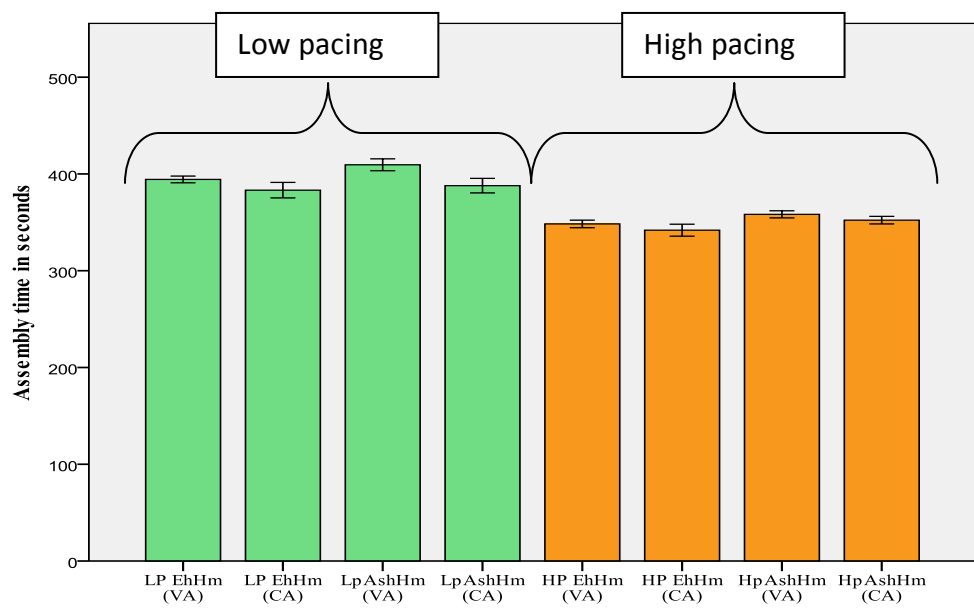

Figure 6-4: Mean and SE of assembly time for each of the 8 conditions in assembly task

6.4.1.2 Completed Assemblies

Each assembly task consisted of fastening 6 nuts and bolts in a row of 6 assembly tasks. Number of completed assemblies was recorded out of 36 assemblies after each condition. A three way (2x2x2) ANOVA showed significant difference between the two levels of pacing ($F=58.67$, $df= 1, 8$, $p<0.001$), the two levels of work height ($F= 15.429$, $df= 1,8$, $p<0.05$) and the two levels of assembly variability ($F= 11.11$, $DF= 1,8$, $p<0.05$). Pair wise comparison of means using Least Significant Different test showed that number of completed assemblies was high at low pacing (36), elbow height (34) and consistent assembly (34.2) than at high pacing (31), above shoulder height (33) and variable assembly (33.4).

ANOVA also showed that there were significant interactions between pacing and work height ($F= 15.42$, $df= 1,8$, $p<0.05$) and between pacing and assembly variability ($F= 11.11$, $DF=1,8$, $p<0.10$). Pair wise comparison of means using Least Significant Difference Test showed that the number of completed assemblies was higher at high pacing + elbow height (33.1) as compared to the number of completed assemblies was lower at high pacing + above shoulder height (30.1). It was also found that the number of completed assemblies was higher at high pacing + consistent assembly (32) as compared to the number of completed assembly was lower at high pacing + variable assembly (30).

The mean (SD) and error bars of completed assemblies for each of the 8 conditions are shown in table 6-2 and figure 6-5.

Low pacing				High pacing			
Elbow height		Above shoulder		Elbow height		Above shoulder	
Variable assembly	Consistent assembly	Variable assembly	Consistent assembly	Variable assembly	Consistent assembly	Variable assembly	Consistent assembly
36.00	36.00	36.00	36.00	32.56	33.67	29.00	31.22
0.00	0.00	0.00	0.00	1.74	1.66	3.04	2.39

Table 6-2: Mean (SD) of completed assembly for each of the 8 conditions in assembly task

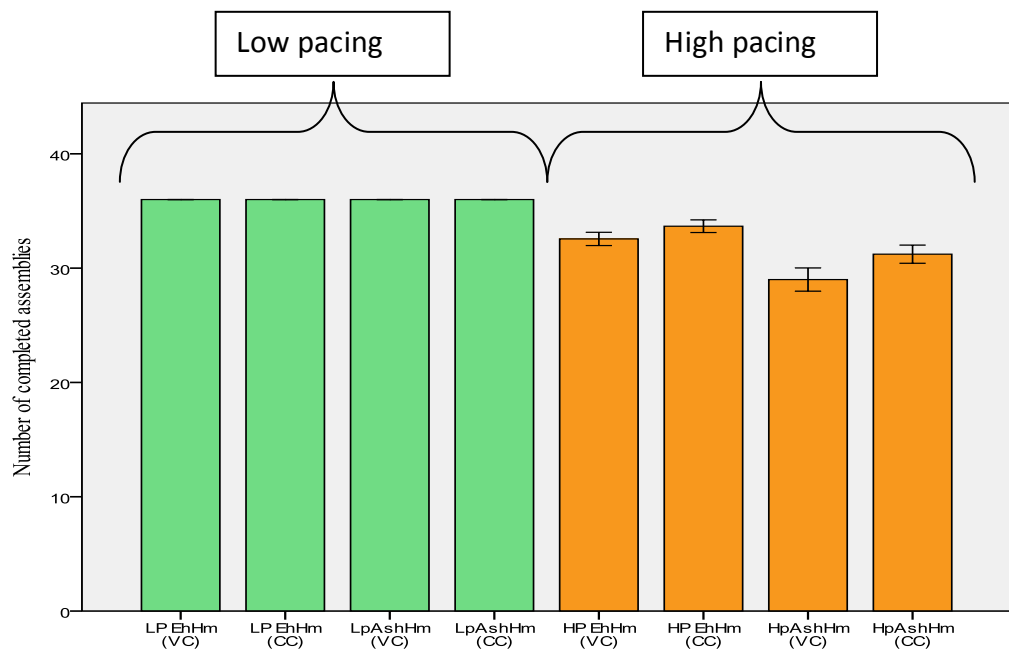

Figure 6-5: Mean and standard error of completed assemblies for each of the 8 condition in assembly task

6.4.1.3 Correct code response

Number of correct code responses out of six responses was recorded after each condition. A three way (2x2x2) ANOVA showed only significant difference between the two levels of assembly variability ($F= 22.30$, $df= 1,8$; $p<0.05$) with the number of correct code responses was lower at variable assembly (2.9) than at consistent assembly (3.9).

Low pacing				High pacing			
Elbow height		Above shoulder		Elbow height		Above shoulder	
Variable assembly	Consistent assembly	Variable assembly	Consistent assembly	Variable assembly	Consistent assembly	Variable assembly	Consistent assembly
2.78 (0.97)	4.11 (0.78)	2.78 (0.97)	3.89 (0.78)	3.00 (1.41)	4.22 (0.97)	2.89 (1.45)	3.44 (1.67)

Table 6-3: Mean (SD) of correct responses for each of the 8 conditions in assembly task

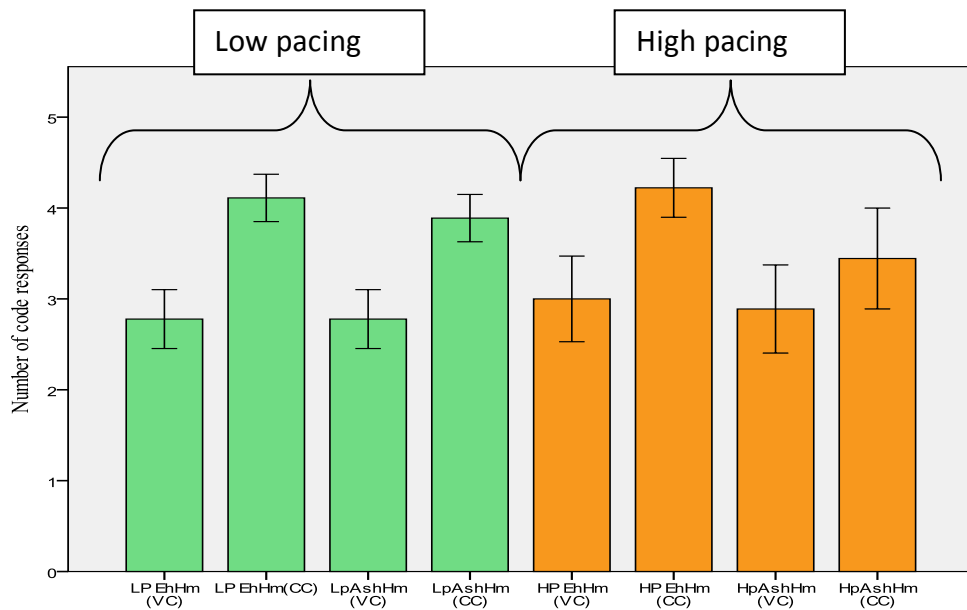

Figure 6-6: Mean and standard error of correct code responses for each of the 8 conditions in assembly task

6.4.1.4 Dropped nuts and bolts

Number of dropped nuts and bolts was recorded out of 36 assemblies during each condition. A three way (2x2x2) ANOVA showed a significant difference between the two levels of work heights ($F= 12$, $df= 1,8$; $p<0.05$). As could be expected and this also supported study 1 that number of drops was higher at above shoulder height than at elbow height. Pair wise comparison of means using Least Significant Difference test showed that numbers of dropped nuts and bolts was high at above shoulder height (8.4) than at elbow height (7.3).

Low pacing				High pacing			
Elbow height		Above shoulder		Elbow height		Above shoulder	
Variable assembly	Consistent assembly	Variable assembly	Consistent assembly	Variable assembly	Consistent assembly	Variable assembly	Consistent assembly
6.44	7.22	7.67	7.56	8.11	7.67	9.11	9.56
3.05	3.49	3.81	3.78	3.37	2.45	3.86	2.51

Table 6-4: Mean (SD) of dropped nuts and bolts for each of the 8 conditions in assembly task

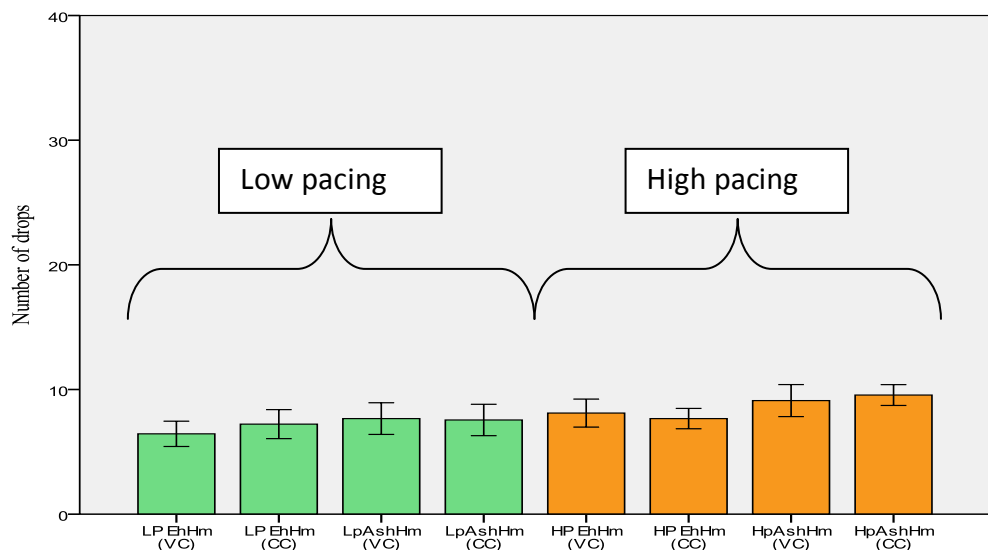

Figure 6-7: Mean and standard error of number of drops for each of the 8 conditions in assembly task

6.4.1.5 Walk time

Walking time between assembly and the computer display was measured through computer generated program in order to analyse any changes in behaviour in terms of partitioning time between the different parts of the task. A three way (2x2x2) ANOVA showed that there was a significant effect of pacing ($F = 26.7$, $df = 1, 8$, $p < 0.05$) on walking time. This also supported study 1 that participant moved with greater speed during high Takt time as compared to low Takt.

Pair wise comparison of means using Least Significant Different test showed that walk time was high at low pacing (27seconds) than at high pacing (19 seconds).

Low pacing				High pacing			
Elbow height		Above shoulder		Elbow height		Above shoulder	
Variable assembly	Consistent assembly	Variable assembly	Consistent assembly	Variable assembly	Consistent assembly	Variable assembly	Consistent assembly
27.11 (1.61)	28.00 (1.07)	27.11 (1.42)	26.11 (1.71)	18.33 (1.46)	18.00 (1.57)	21.67 (1.44)	20.56 (1.31)

Table 6-5: Mean (S.E) of interaction between pacing and work height for walk time

6.4.2 Subjective Measures

6.4.2.1 NASA TLX dimensions

Workload was measured using 5 dimensions of NASA TLX: mental demand, physical demand, temporal demand, performance and effort. Raw NASA TLX rating scales were used to collect the data. The results and analysis for each dimension are discussed below.

6.4.2.1.1 Perceived mental demand

Perceived mental demand was measured on the raw NASA TLX scale ranging from 0 as low and 20 as high. A three way (2x2x2) repeated measures ANOVA was performed to analyse the effects of pacing, work height and assembly variability on perceived mental demand. ANOVA showed that there were significant differences due to two levels of pacing ($F=5.64$, $df= 1, 8$, $p<0.05$), and two levels of assembly variability ($F= 8.904$, $DF= 1, 8$, $p<0.05$).

Subjective response for mental demand was found to be high due to high pacing/ Takt and variable assembly order. Mean perceived mental demand at low pacing and at high pacing were 14.9(0.5) and 15.6(0.5) respectively. Mean perceived mental demand in variable assembly and consistent assembly were 15.9(0.4) and 14.6(0.7) respectively.

Low pacing				High pacing			
Elbow height		Above shoulder		Elbow height		Above shoulder	
Variable assembly	Consistent assembly	Variable assembly	Consistent assembly	Variable assembly	Consistent assembly	Variable assembly	Consistent assembly
15.78	13.89	15.33	14.78	16.56	14.89	16.00	14.78
1.72	2.42	1.73	2.05	1.24	2.37	2.06	2.59

Table 6-6: Mean (SD) of perceived mental demand for each of the 8 conditions in assembly task

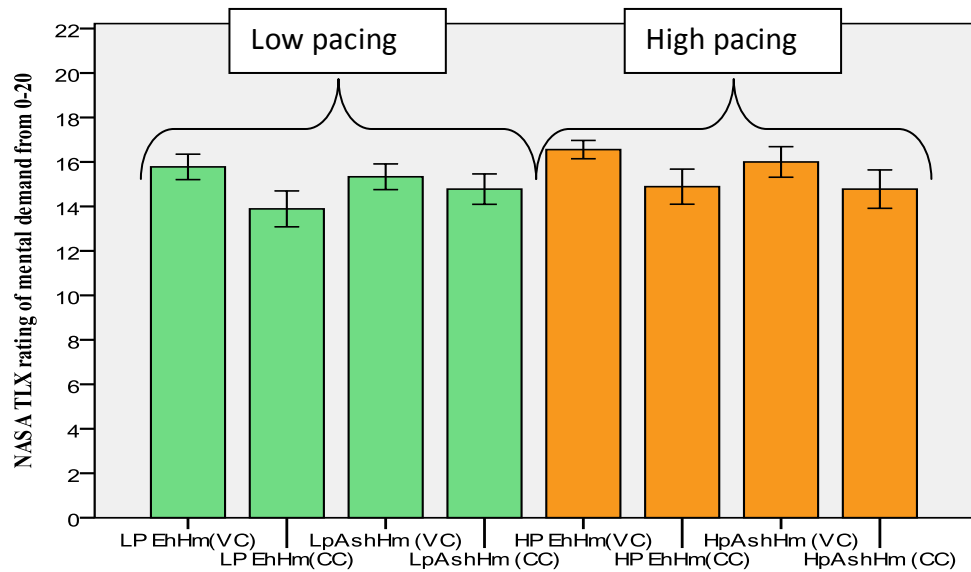

Figure 6-8: Mean and standard error of each condition of mental demand

6.4.2.1.2 Perceived physical demand

Physical workload data was collected on the raw NASA TLX scale ranging from 0 as low and 20 as high. A three way (2x2x2) repeated measures ANOVA was performed to analyse the effects of pacing, work height and assembly variability on perceived physical workload and to determine whether there were any interaction effects. ANOVA showed that there was a significant difference due to work height ($F=27.013$, $df= 1, 8$, $p<0.05$). Pair wise comparison of means using Least Significant Difference test showed that perceived physical demand as in study 1, was higher at above shoulder height (12.7) than at elbow height (8.7).

Low pacing				High pacing			
Elbow height		Above shoulder		Elbow height		Above shoulder	
Variable assembly	Consistent assembly	Variable assembly	Consistent assembly	Variable assembly	Consistent assembly	Variable assembly	Consistent assembly
8.22	8.00	12.11	12.89	9.33	9.33	13.33	12.44
2.49	3.28	2.89	3.37	2.74	2.92	3.67	2.70

Table 6-7: Mean (SD) of perceived physical demand for each of the 8 conditions in assembly task

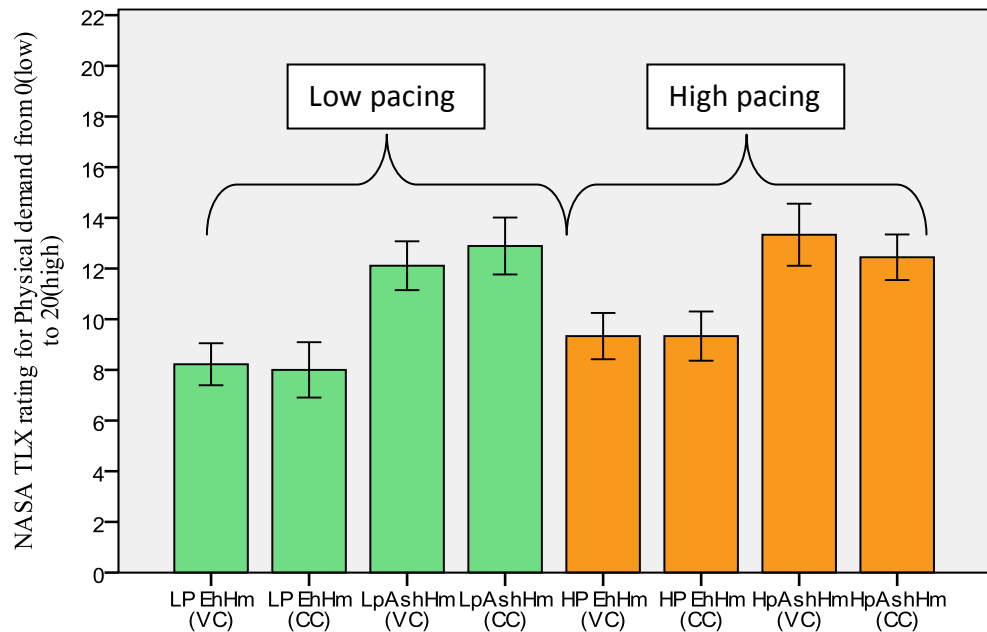

Figure 6-9: Mean and standard error of Physical demand for each condition of physical demand

6.4.2.1.3 Perceived temporal demand

Perceived temporal demand data was collected on the raw NASA TLX scale ranging from 0 as low and 20 as high. A three way (2x2x2) repeated measures ANOVA was performed to analyse the effects of pacing, work height and assembly variability on perceived temporal demand and to determine whether there were any interaction effects. ANOVA showed significant difference due to levels of pacing ($F=29.051$, $df= 1, 8$, $p<0.05$). Participants responded high temporal demand while working at high Takt time. Pair wise comparison of means using least significant different test showed that the perceived temporal demands was high at high pacing (13.1) than at low pacing (7.2)

Low pacing				High pacing			
Elbow height		Above shoulder		Elbow height		Above shoulder	
Variable assembly	Consistent assembly	Variable assembly	Consistent assembly	Variable assembly	Consistent assembly	Variable assembly	Consistent assembly
6.44	7.00	7.11	8.33	13.67	12.56	12.89	13.22
2.79	2.65	2.26	3.64	2.96	3.00	3.02	2.59

Table 6-8: Mean (SD) of perceived temporal demand for each of the 8 conditions in

assembly task

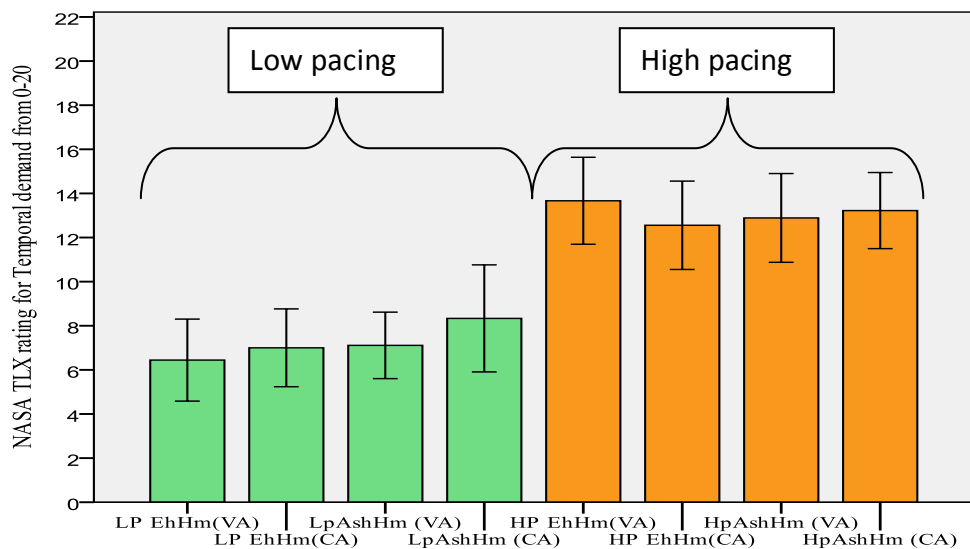

Figure 6-10: Mean and standard error of temporal demand for each of the 8 conditions in assembly task

6.4.2.1.4 Perceived performance

Data on the perceived performance dimension was collected on the raw NASA TLX scale ranging from 0 as perfect and 20 as failure. A three way (2x2x2) repeated measure ANOVA was performed to analyse the effects of pacing, work height and assembly variability on perceived performance and to determine whether there were any interaction effects. ANOVA showed significant difference due to the levels of pacing ($F=8.686$, $df= 1, 8$, $p<0.05$). The higher value in performance scale leads to failure, which is different from other dimensional scales of NASA TLX. Perceived performance was found to be worse at high pacing/ Takt as compared to low pacing / Takt. Mean perceived performances at low pacing and at high pacing were 6.6 and 8.2 respectively.

Low pacing				High pacing			
Elbow height		Above shoulder		Elbow height		Above shoulder	
Variable assembly	Consistent assembly	Variable assembly	Consistent assembly	Variable assembly	Consistent assembly	Variable assembly	Consistent assembly
6.89	6.56	6.78	6.11	8.67	7.89	8.56	7.78
3.62	3.54	3.49	3.82	3.71	3.79	4.00	3.46

Table 6-9: Mean (SD) of perceived performance for each of the 8 conditions in

assembly task

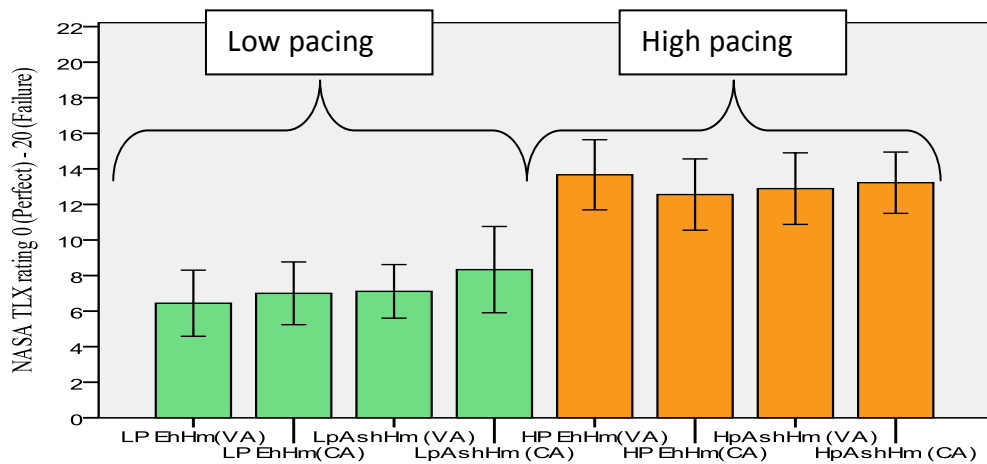

Figure 6-11: Mean and SE of Perceived performance for each of 8 conditions in

assembly task

6.4.2.1.5 Perceived effort

Data on perceived effort dimension was collected on the raw NASA TLX scale ranging from 0 as low and 20 as high. A three way (2x2x2) repeated measure ANOVA was performed to analyse the effects of pacing, work height and assembly variability on perceived effort and to determine whether there were any interaction effects. ANOVA showed significant differences due to all three independent variables: pacing ($F=5.960$, $df= 1, 8$, $p<0.05$), work height ($F=5.612$, $df= 1, 8$, $p<0.05$) and assembly variability ($F= 7.808$, $df= 1, 8$, $p<0.05$). However, no interaction was found. Mean perceived efforts at low pacing and at high pacing were 12.1 and 13.4 respectively. Mean perceived efforts at elbow height and above shoulder height were 12.3 and 13.2 respectively. Mean perceived efforts for variable assembly and consistent assembly were 13.1 and 12.4 respectively.

Low pacing				High pacing			
Elbow height		Above shoulder		Elbow height		Above shoulder	
Variable assembly	Consistent assembly	Variable assembly	Consistent assembly	Variable assembly	Consistent assembly	Variable assembly	Consistent assembly
12.33	11.56	13.00	11.67	13.00	12.44	14.00	14.11
2.40	3.09	2.50	3.08	4.50	3.43	3.57	3.76

Table 6-10: Mean (SD) of perceived effort for each of the 8 conditions in assembly

task

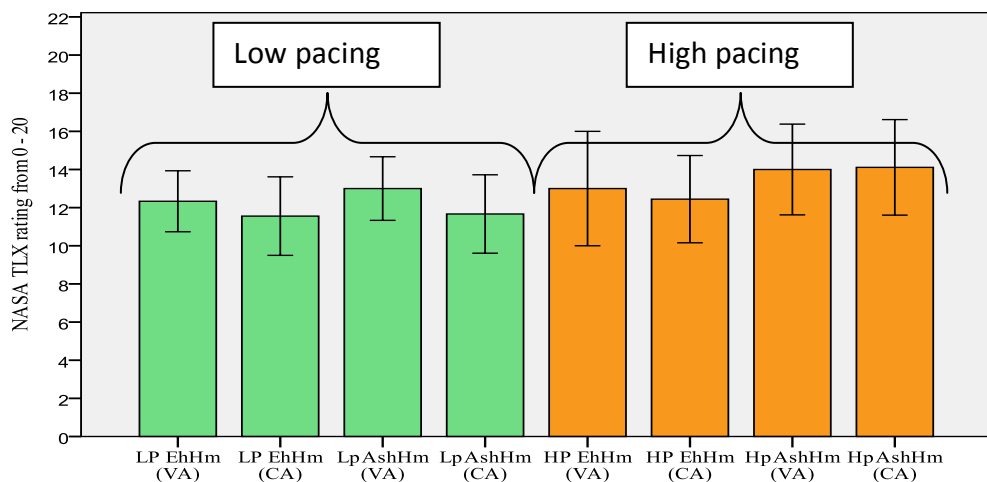

Figure 6-12: Mean and SE of Perceived Effort for each of 8 conditions in assembly

task

6.4.2.2 Stress And Arousal

Data on stress and arousal was collected using stress and arousal checklist. Subjects scored on 30 adjectives about their mood after each condition.

6.4.2.2.1 Stress score

A three way (2x2x2) repeated measures ANOVA was performed to analyse the effects of pacing, work height and assembly variability on stress score and to determine whether there were any interaction effects. ANOVA showed significant differences due to levels of pacing (F=7.087, df= 1, 8, p<0.05), and levels of assembly variability (F= 8.516, DF= 1, 8, p<0.05). Pair wise comparison showed that perceived stress was higher at high pacing (13.4) and variable assembly (13.1) than at low pacing (12.1) and consistent assembly (12.4) respectively.

Low pacing				High pacing			
Elbow height		Above shoulder		Elbow height		Above shoulder	
Variable assembly	Consistent assembly	Variable assembly	Consistent assembly	Variable assembly	Consistent assembly	Variable assembly	Consistent assembly
34.00	31.33	35.22	33.11	36.56	34.00	37.56	36.44
7.42	8.44	5.87	5.75	7.35	5.81	7.13	7.00

Table 6-11: Mean (SD) of stress score for each of the 8 conditions in assembly task

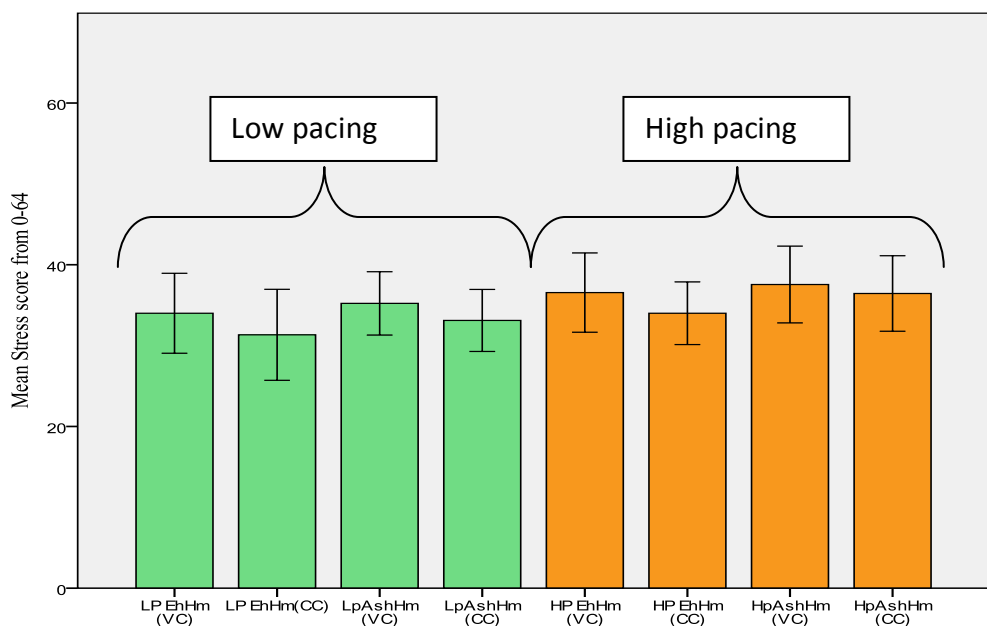

Figure 6-13: Mean and SE of Stress score for each of the 8 conditions in assembly task

6.4.2.2.2 Arousal score

A three way (2x2x2) repeated measures ANOVA was performed to analyse the effects of pacing, work height and assembly variability on arousal score and to determine whether there were any interaction effects. ANOVA showed significant difference due to levels of pacing ($F=5.806$, $df= 1, 8$, $p<0.05$).

Arousal was also found to be high due to high pacing. Mean arousal scores at low pacing and at high pacing were 29.3 and 32.2 respectively.

Low pacing				High pacing			
Elbow height		Above shoulder		Elbow height		Above shoulder	
Variable assembly	Consistent assembly	Variable assembly	Consistent assembly	Variable assembly	Consistent assembly	Variable assembly	Consistent assembly
29.44	28.56	29.22	30.11	31.78	32.00	33.33	31.67
4.16	3.36	4.99	3.86	5.12	5.59	6.44	5.83

Table 6-12: Mean (SD) of arousal score for each of the 8 conditions in assembly task

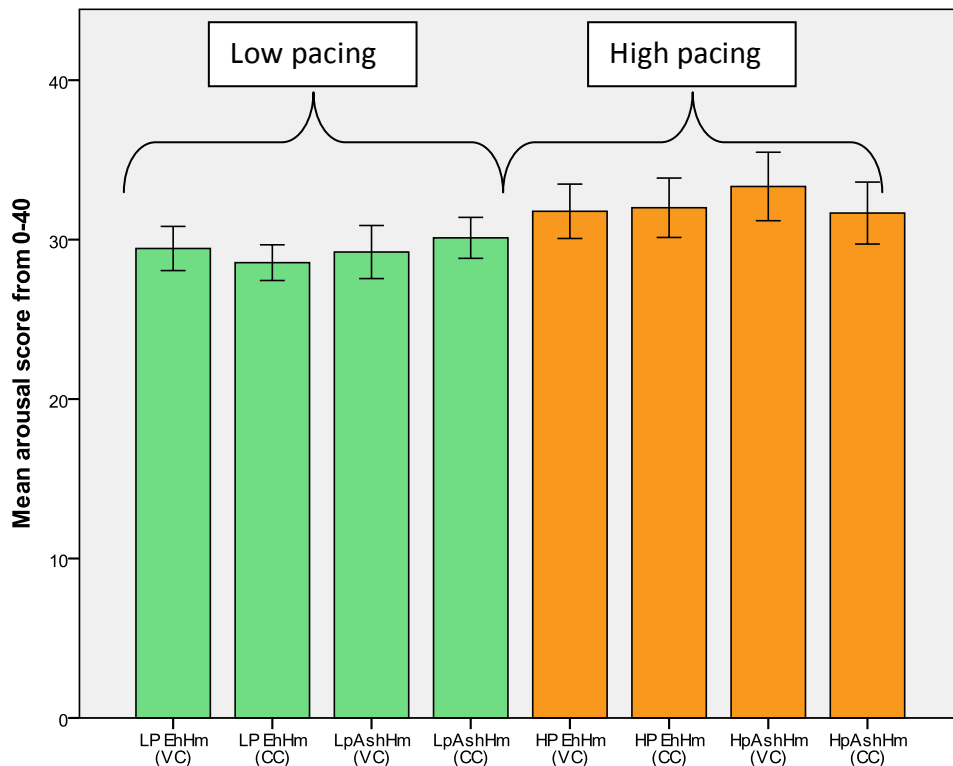

Figure 6-14 : Mean and SE of Arousal for each of the 8 conditions in assembly task

6.4.2.3 Fatigue

Perceived fatigue was measured using a rating scale from 0 (energetic, lively) to 10 (extremely tired or fatigued). A three way (2x2x2) repeated measure ANOVA showed no significant effects of levels of pacing, levels of work height and levels of assembly variability and interaction between them on perceived fatigue. The mean (SD) of perceived fatigue for each of 8 conditions in assembly task are shown in table 6-17.

Low pacing				High pacing			
Elbow height		Above shoulder		Elbow height		Above shoulder	
Variable assembly	Consistent assembly	Variable assembly	Consistent assembly	Variable assembly	Consistent assembly	Variable assembly	Consistent assembly
2.00	2.00	2.22	2.00	1.22	1.44	1.56	2.11
2.60	2.78	2.73	2.69	1.99	1.94	2.13	2.85

Table 6-13: Mean (SD) of perceived fatigue for each of the 8 conditions in assembly task

6.5 Main Findings of study 2

Study 2 was designed to be more demanding by manipulating simple assembly task into assembly variability that represented single model assembly line (SMAL) and mixed model assembly line (MMAL). Memory load was also increased to 8-digits, which was kept same in all 8 conditions. These changes were predicted to make the task more cognitively demanding.

Tables 6-14 and 6-15 present the summary results of study 2 for objective measures and subjective measures respectively. The overall main findings of study 2 were as follows;

- The two levels of pacing affected the actual assembly time, number of completed assemblies and walk time, which revealed that participants were unable to finish their assembly task, and fully completed assemblies under high pacing / Takt time of 60 seconds per assembly task. This supported the findings of study 1. It was also found as in study 1 that participant moved more frequently between assembly task and computer display due to hi pacing conditions.
- Assembly time, number of completed assemblies and number of drops were affected due to above shoulder height, which also supported the findings of study 1.
- Manipulation in study 2 in the form of introducing variable assembly was predicted to make the task more demanding. This prediction was confirmed with assembly time, number of correct responses and number of fully completed assemblies.
- An interaction between pacing and work height affected the number of fully completed assemblies and walk time due to high pacing and above shoulder height.

- Subjective responses (Raw NASA TLX) and stress and arousal score were also affected by pacing, work height and assembly variability. However, no interaction was found.
- Perceived Mental demand, temporal demand, performance and effort were affected due to high pacing condition. Perceived Stress and arousal score were also affected due to high pacing, which revealed that the high paced assembly was more mentally demanding
- Similarly variable assembly order affected the mental demand, effort and stress. This was an interesting finding that differentiates the level of cognitive demand between variable assembly and consistent assembly.

Independent variables	Objective Measures				
	Actual assembly time	Number of correct responses	Fully completed assemblies	Walking time	Number of dropped nuts and bolts
Pacing df =1,8	F=126.5** LP>HP	F=0.01	F=58.7** LP>HP	F=26.7* LP>HP	F=1.0
WH df =1,8	F=12.8** ASH>EH	F=0.8	F=15.4** EH>ASH	F=3.0	F=12.0** ASH>EH
AV df =1,8	F=7.4* CA>VA	F=22.3** CA>VA	F=11.1* CA>VA	F=0.2	F=0.3
Pacing X WH df =1,8	F=0.6	F=0.5	F=15.4** HP+ASH< HP+EH	F=9.7* HP+AS H>HP+ EH	F=2.5
Pacing X AV df=1,8	F=0.7	F=0.6	F=11.1* HP+VA< HP+CA	F=0.2	F=0.3
WH X AV df =1,8	F=0.4	F=0.9	F=2.0	F=1.2	F=0.2
Pacing X WH X AV df=1,8	F=0.5	F=0.4	F=2.0	F=0.2	F=0.2

Table 6-14: Summary results of the ANOVAs for objective measures

* p <0.05, ** p<0.01 WH - Work height, AV - Assembly variability
LP - Low pacing, HP - High pacing, ASH - Above shoulder height, EH - Elbow height, VA - Variable assembly order, CA - Consistent assembly order

Independent variable	Dependent variable							
	NASA TLX					PWC	Stress & Arousal scores	
	Mental demand	Physical demand	Temporal demand	Performance	Effort	Fatigue	Stress	Arousal
Pacing df =1,8	F=5.6* LP< HP	F=1.2	F=29.1** HP> LP	F=8.7* HP> LP	F=6.0* HP> LP	F=3.52	F=7.1* HP> LP	F=5.9* HP> LP
WH df=1,8	F=0.1	F=27.0** ASH>EH	F=3.7	F=0.1	F=5.6* ASH>EH	F=3.02	F=2.4	F=0.8
AV df=1,8	F=8.9* VA>CA	F=0.1	F=0.4	F=4.2	F=7.8* VC>CA	F=0.442	F=8.5* VC>CA	F=0.5
Pacing X WH interaction df =1,8	F=0.5	F=2.0	F=1.2	F=0.5	F=3.3	F=1.00	F=0.01	F=.003
Pacing X AV interaction df=1,8	F=0.2	F=0.7	F=1.8	F=0.2	F=0.9	F=2.00	F=0.4	F=1.0
WH X AV interaction df=1,8	F=3.1	F=0.01	F=2.2	F=0.1	F=0.02	F=0.031	F=0.8	F=0.01
Pacing X WH X AV interaction df=1,8	F=2.1	F=1.8	F=0.4	F=0.1	F=1.7	F=0.847	F=0.3	F=0.3

Table 6-15 Overlead: Summary results of the ANOVAs for subjective measures

* p <0.05, ** p<0.01 WH - Work height, AV - Assembly order variability

LP - Low pacing, HP - High pacing, ASH - Above shoulder height, EH - Elbow height, VA - Variable assembly order, CA - Consistent assembly order

6.6 Discussion

The overall aim of the research is to investigate the effects of physical and cognitive demands under simultaneous performance of physically and cognitively demanding task on the performance and subjective responses and to determine whether they interact in their effects. The specific objective of study 2 was to investigate the effects cognitive aspects of task (assembly variability and code memory) on quality of performance and subjective responses. Study 2 was manipulated from study 1 to have a longer memory code of 8 digits, which was understood to be at the limits of working memory (Miller, 1956). It also compared single with mixed model assembly, which was also predicted to be more complex (Sood et al., 2007).

Results revealed that time to finish the assembly task were higher in variable assembly as compared to consistent assembly. The number of assemblies fully completed and number of correct code recall responses were both lower with a variable assembly order. Previous studies have also shown similar effects of high pacing on workload and performance (Ikuma et al., 2009, Dempsey et al., 2010). Two dimensions of NASA TLX (mental demand and effort) indicated perceived higher workload of variable assembly order as compared to a consistent assembly order. Stress was also higher with a variable assembly order. It was thus found that a variable assembly order, as occurs in a mixed model assembly line, has a significant effect on both performance and perceived workload and stress.

The objective and subjective measures were also affected by pacing (low pacing with a Takt time of 90 seconds and high pacing with a Takt time of 60 seconds per assembly). Actual assembly time, number of fully completed assemblies and walking time were affected by the pacing levels. Not all the participants were able to finish all their assemblies within the Takt time allowed under the high pacing conditions, whereas the participants found the

low pacing quite comfortable and could all finish the assemblies quite early, giving some waiting (rest) time before they had to move for the next assembly. Pacing levels also affected the subjective responses. It can be seen from Table 6-3 that the mental workload score of NASA TLX was higher under high pacing as were temporal demand, performance and effort scores. However, the physical demand score was not affected by pacing. Stress and arousal levels were also affected by the high pacing.

It is of course generally accepted that working at above shoulder height is highly physically demanding, as confirmed in the present study, but it was also shown to affect the performance measures of actual assembly time, number of fully completed assemblies and number of dropped nuts and bolts. The physical demand and effort scores of NASA TLX were also affected by the above shoulder work height. However, it did not affect stress and arousal levels.

There were two aspects of cognitive load in the present study: the first procedural in assembling the components in a particular order (consistent or variable) and the second memorising the 8-digit product code during the assembly task. Variable assembly order was found to be perceived to be more mentally demanding as can be seen from Table 6-15, and in addition more errors were made in recall of product codes when the order was variable (as shown in Table 6-14).

Chapter 5 explained the results of study 1 in relation to Armstrong's dose capacity model and Wicken's multiple resource model. Study 2 was modified to be more cognitively demanding by changing the fastening task into assembly variability operation (representing single model assembly line and mixed model assembly line operation) and memory code was increased to 8 digit.

It has been found that performance has been affected due to high pacing/ Takt, work height (at above shoulder height) and assembly order (at variable assembly) at both objective and subjective measures as can be seen from

table 6-14 and 6-15. Two interactions (pacing and workheight; pacing and assembly order) have been found to have significant effects on performance at objective measures.

These results could have relations with theoretical models of Armstrong dose capacity model (1993) and Wickens multiple resource model (2002). As far as, the Armstrong dose capacity model is concerned, the main objective was to understand how physical and cognitive demands combine to act as dose that may lead to physical and psychological responses. The variable assembly order (representing MMAL) required the fastening of nuts and bolts in random order. This demanded both physical (fastening task) and cognitive (pick the required required nut and fasten at the required place) along with other physical (workheight) and cognitive (memorising the code) demands under pacing/ Takt conditions. Variable assembly order, in this regard has been found to be more demanding and acted as dose that led to affect the performance physically (assembly time, correct responses and number of completed assemblies) and psychologically (increased mental demand and effort of NASA TLX and increase stress).

Moreover, assembly order as discussed above consisted of consistent assembly order (which does not require verbal resource) and variable assembly order (which requires verbal resource). Therefore, the results, according to Wickens multiple resources model, revealed that performance suffered more at variable assembly order due to different attention resources used at variable assembly order (verbal and visuo-spatial) than resources used at consistent assembly order (visuo-spatial).

chapter 8 further discuss in detail about the theoretical understanding of results in relation of different models.

6.7 Summary

The particular objective of this study was to investigate the effects of changing variables (variable assembly and consistent) on the quality of performance assessments of workload, stress and arousal, and fatigue and discomfort, as well as to find whether any of these interacted in their influence for a paced assembly task. It was found that performance when the assembly order is variable (as in a mixed model production assembly line) may have more errors and quality problems, especially under high pacing conditions or when working in a poor posture (at above shoulder height). This is an important issue for companies in terms of productivity and quality. Thus, the design of tasks on a mixed model assembly line needs careful consideration in terms of task complexity, workplace layout and Takt time specification (or level of pacing).

There were two limitations of the study. The first was the small number of participants ($n = 9$). A second, confounding aspect of the current study was the nature of cognitive load, that came in part from assembly order (variable assembly and consistent assembly) as the realistic part of the task, and also from memorising the 8-digit code during the assembly task as the secondary part of the task. There is the possibility that the specific nature of the cognitive demand of variable assembly (number based ordering of bolts) had a more profound effect on numeric code recall, because it competed for the auditory loop element of working memory (Baddeley and Hitch, 1974), than other potential sources of cognitive load (e.g. colour based coding of assembly).

Study 1 was modified to be more demanding as the results showed ceiling effects. In study 2, the overall task was highly mental demanding, indicated by subjective mental workload, as was the intention in designing the experimental conditions for high mental demand in Study 2. However, it was

also difficult to analyse the effects of 8 –digit memory load as a secondary task on the assembly variability as both of these factors were changed simultaneously in comparison with the experimental conditions in Study 1. Therefore, study 3 was designed by combining the essential aspects of study 1 and study 2 in order to analyse in detail the effects of changing variables on the performance and subjective responses. The detailed description of study 3 is discussed in chapter 7.

7 Study 3 – Cognitive load and high pacing / Takt

7.1 Introduction

Chapter 6 (describing Study 2) showed an interesting effect that the performance under variable assembly order was more demanding than consistent assembly order. As the memory load was increased to 8 digits in Study 2 and kept constant for all the conditions, the overall task was found to be more mentally demanding. This was proved by analysing the correct code responses and perceived mental demand. It was also found that the overall task was highly mental demanding, indicated by subjective mental workload, as was the intention in designing the experimental conditions for high mental demand in Study 2. This formed the basis for keeping the assembly order variable the same in the study 3.

However, it was difficult to analyse the effects of 8–digit memory load as a secondary task on the assembly variability. Both of these factors were changed simultaneously in comparison with the experimental conditions in Study 1. Therefore study 3, used the varied assembly order (from study 2) across all conditions and used memory load as an independent variable (from study 1) and thus permitted investigation of the effects of the two different factors. This allowed the study of whether the cognitive variables of the task (levels of assembly order and two levels of memory) interacted with physical load (elbow and shoulder height).

7.2 Experimental design and Task Analysis

Based on the results achieved from study 1 and study 2 relating to the effects of physical and cognitive demands due to simultaneous performance on the task performance and subjective responses, study 3 was carried out to specifically to understand the effects of physical load on the cognitive aspects of the assembly task. A similar design of simulated study was used in all three studies. However, slight changes were made under study 2 and study 3.

The design of study was the combination of essential components of study 1 and study 2. The physical aspect of the task in the laboratory simulated the assembly of components and consisted of attaching and tightening six wing nuts on threaded bolts. This was repeated for six cycles in each experimental condition. There were six assembly tasks in a row. The task was performed while standing with the work height being at either elbow level or above shoulder level. The cognitive aspect of the task was to memorise the product code number (as presented on a computer screen) and to enter this number immediately before starting the assembly and then again after its completion. The code was generated randomly for each assembly. Figures 7-1 shows presentation of task analysis with one box (3.1) coloured in blue, which represents the changes made in study 3, whereas, figure 7-2 shows experimental design with two levels for each of three independent variables in assembly task.

Based on the results achieved from study 1 and 2 and by comparing the trends between the two studies, more focus was given on investigating the effects of cognitive aspects of the task and how these might interact with physical load and vice versa. As far as pacing/ Takt time was concerned in study 2, the “no pacing” condition was omitted due to no difference being found in Study 1 between “no pacing” and “low pacing”. Likewise in study 3, low pacing was omitted as there was a need to clearly understand about the effects of cognitive of task on physical load under high pacing conditions, as well as there being a need to manage the number of independent variables in the study. Therefore, in study 3, all conditions were performed under high pacing, since this is likely to provide greatest contrast in responses.

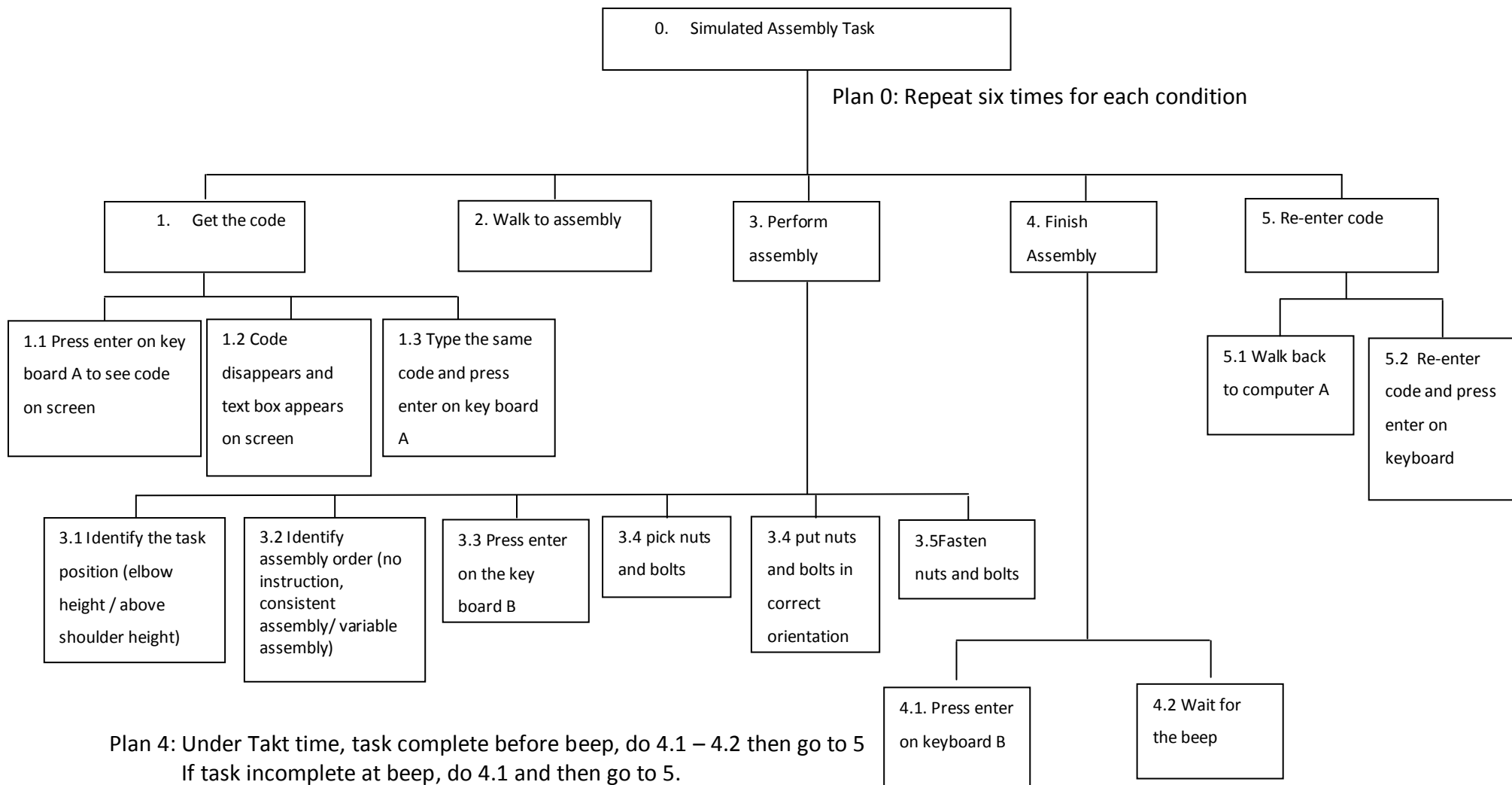

Figure 7-1 (overleaf): Hierarchical task analysis for the simulated assembly task in study 3

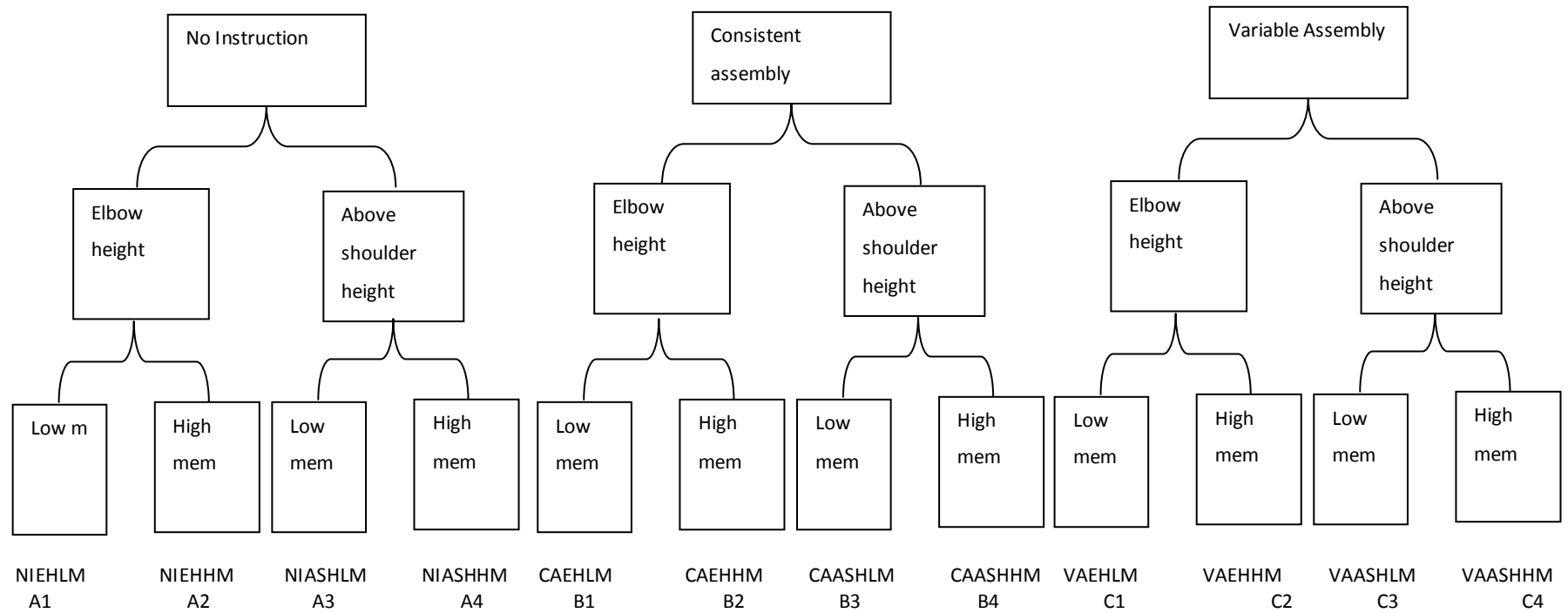

Figure 7-2: Experimental design with two levels for each of three independent variables in assembly task

7.3 Method

7.3.1 Participants

The same participants were recruited for both study 1 and study 2 to compare the effects. However, in study 3, different participants were used to ensure findings were not a result of using a limited sample. 12 participants were recruited from staff or student of Nottingham University. 6 males and 6 females participants with the mean (S.D) age 29.6(6.5) participated in the experimental study. All participants were screened to be physically and mentally healthy through a general well being questionnaire.

7.3.2 Procedure

The experiment lasted for approximately 3.5 hours for each participant. Figure 7-3, describes the breakdown of time based on the task performed under predetermined condition. The experiment consisted of 12 conditions (four conditions under no instruction (participant's own choice of order of assembly), 4 conditions under instructions (consistent assembly order) and 4 conditions under instructions (variable assembly order)) as shown in figure 7-2. These three levels of the "task" factor had been chosen to cover the conditions tested in Studies 1 and 2 and to permit a direct comparison between them (which was not possible previously because the task was changed in two ways between Studies 1 and 2, as well as more direct instructions being given to participants in Study 2 than in Study 1). All NO INSTRUCTION conditions were performed first by each participant and the four conditions were randomised. After that, the CONSISTENT ASSEMBLY conditions and VARIABLE ASSEMBLY conditions were performed in alternative order by two groups of the participants (i.e, 6 participants performed INSTRUCTION CONSISTENT as a second session and INSTRUCTION VARIABLE as a third session).

There was a practice session, which was conducted on the condition [No instruction, elbow work height and low memory load]. The practice session was carried for 5 minutes on no instruction conditions in order completely

familiarise the assembly task. There was a 5 minute break between conditions. During the break, the participant completed the subjective rating scales.

In each condition the participant performed six repetitions of the assembly task. As in the previous two studies, the task was to attach six nuts and bolts to a plate, in a given order that is identified on the plate. However, for No Instruction, there was no identification of any order as in study 1.

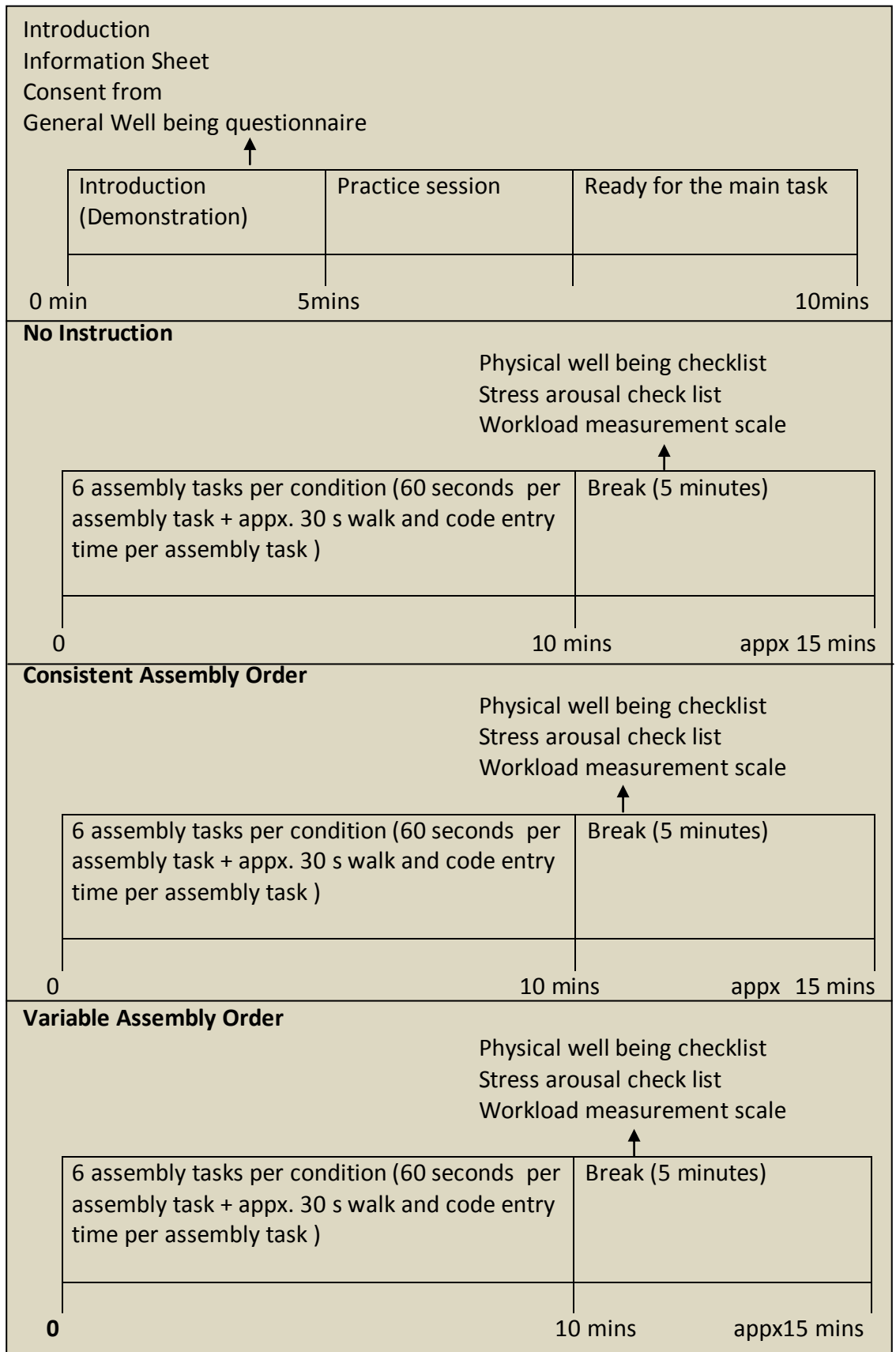

Figure7-3: Sequence of procedure

7.3.3 Independent Variables

The following independent variables were manipulated in study 3.

7.3.3.1 *Physical demand*

Work height with two levels (elbow height and above shoulder) was kept the same in all the three studies. Almost similar effects due to work height on objective and subjective measures were found in study 1 and 2. The main reason for keeping the work height same in all the three studies is that a similar effect was found on perceived physical demand in study 1 and 2.

7.3.3.2 *Cognitive demand*

In study 3, cognitive demand has been divided in to two categories, which are discussed as below;

Assembly task Study 3 consists of three levels of assembly order as below;;

- i. No instructions as to the order in which the assembly should be carried out. There was no display of number on the assembly plate, which was carried out exactly same as in study 1. Therefore there is no potential source of interference between assembly order and memory code.
- ii. Instruction (consistent assembly order). This level is the same as in study 2, which demonstrates that the display of number remains constant in all the 6 assembly plates in a row. Therefore, while there is a numerically-based assembly order, the participant is not required to encode a specific numeric sequence for each assembly and interference between memory code and assembly order in working memory is predicted to be minimal.
- iii. Instructions (Variable assembly order). This is also taken from study 2, which demonstrates display of codes in random order on the all the 6 assembly plates in a row. Therefore, there is a potential interference between assembly order and memory code in working memory.

7.3.3.3 Memory load

Low memory: A 6 digit code was memorised during the assembly task (as from study 1).

High memory: An 8 –digit code was memorised during the assembly task (as from study 2)

Independent variable	Level	Description
Assembly order / Pacing (by Takt time)	No Instruction	Takt time 60 seconds
	Variable Assembly	Takt time 60 seconds
	Consistent Assembly	Takt time 60 seconds
Physical demand (work height)	Elbow height	Lower arm parallel to ground making 90 degree with the lower arm
	Above shoulder height	Upper arm parallel to ground making 90 degree with the upper arm
Cognitive demand (memory load)	Low load	Memorising 6 digit code
	Higher load	Memorising 8 digit code

Table 7-1: Levels of independent variable

7.3.4 Dependent Variables

The dependent variables in study 3 are discussed as below;

7.3.4.1 Quality of performance

Quality of performance was measured to analyse the effects of different nature of assembly tasks along with imposed memory load on physical and mental stresses. Quality of performance was measured as;

- i. Assembly time
- ii. Number of fully completed assemblies
- iii. Number of drops
- iv. Number of correct code responses

The following methods were used measure the objective responses;

- Observational checklist to measure the number of fully completed assemblies and number of drops for each assembly task
- Exact time of assembly, total time and number of code responses for each assembly task will be measured through computer program

7.3.4.2 Subjective responses

Perceived workload, fatigue and stress and arousal levels were subjectively measured to analyse the effects of cognitive aspects of tasks on physical load and vice versa

1. Subjective responses were measured through;
 - NASA TLX
 - Physical well being Checklist
 - Stress and arousal checklist

7.4 Results

7.4.1 Test for assumption and results

Each dependent variable was tested to check whether the assumptions for Analysis of Variance (ANOVA) had been met. Tests for normality using z-skew showed $z < 1.96$ for each experimental condition. Therefore, the ANOVA was conducted on the raw data collected through objective measures and subjective responses. However, Mauchly's test for sphericity was not met for only one dependent variable as showed significance in the variances of actual assembly time. Further description is discussed in relevant section of assembly time.

After performing the assumption tests, A 3-way (3x2x2) repeated measure analysis of variance (ANOVA) was conducted to investigate whether the effects of cognitive aspects of task (consistent assembly or variable assembly and low /high memory load) interacted with those of work height. Pair wise comparison of means using the Least Significant Difference test was used to conduct the post hoc analysis.

A table of mean and standard deviation scores for each dependent variable is presented under each measure of the dependent variable. A graphical display of means and standard errors are presented in a bar chart showing 12 conditions of assembly task under each objective and subjective measure. Different colours are used in the bar chart to differentiate the no instruction assembly (blue), consistent assembly (green) and variable assembly (orange).

7.4.2 Objective measures

7.4.2.1 Assembly Time

It was predicted that the participant might take more time during variable assembly order than during no instruction and consistent assembly order. Mauchly's test indicated that the assumption of sphericity had been violated, $\chi^2(2) = 7.54$, $p = 0.023$. Therefore, degrees of freedom were corrected using Greenhouse Geisser estimates of sphericity ($\epsilon = 0.66$). A three way repeated measured ANOVA was performed to analyse the three levels of assembly order, two levels of work height and two levels of memory load on dependent variables and to determine the effect of cognitive aspect on physical load.

Based on the Greenhouse Geisser estimates of sphericity, results showed significant effects between two levels of work height ($F = 24.23$, $df = 1, 11$, $p < 0.01$) and two levels of memory load ($F = 5.67$, $df = 1, 11$, $p < 0.05$). Pair wise comparison of means using Least Significant Difference test showed that time to complete the assembly task was higher at above shoulder high (354 seconds) than at elbow height (345). Time to complete assembly task was also high at high memory load (351 seconds) than at low memory (348).

ANOVA also showed significant interaction between three levels of assembly order and two levels of memory load ($F = 3.89$, $df = 2, 22$, $p < 0.05$). Post hoc analysis showed that time to finish the assembly was higher at no instruction assembly + high memory (350 seconds) than at no instruction assembly + low memory (342 seconds).

No Instruction				Variable Assembly				Consistent			
Elbow height		Above shoulder		Elbow height		Above shoulder		Elbow height		Above shoulder	
Low	High	Low	High	Low	High	Low	High	Low	High	Low	High
336.50	344.00	348.42	355.92	346.42	347.67	353.00	354.75	350.33	349.50	354.92	358.67
(15.75)	(15.20)	(17.85)	(7.30)	(20.05)	(14.27)	(13.62)	16.15	15.85	14.29	9.83	12.60

Table 7-2: Mean (SD) of assembly time for each of the 12 conditions in assembly task

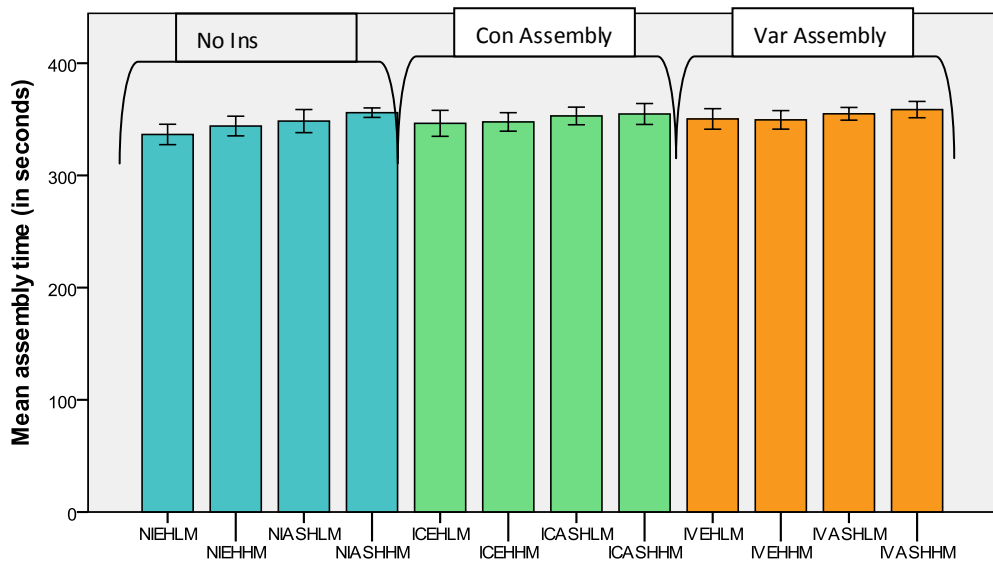

Figure 7-4: Mean (S.E) of assembly time for each condition of 12 conditions in assembly tasks

7.4.2.2 Number of correct code responses

A three way (3x2x2) repeated measure ANOVA showed significant effects on number of code responses due the three levels of assembly order ($F=14.72$, $df=2,22$, $p<0.01$), two levels of work height ($F=5$, $df=1,11.5$, $p<0.05$) and two level of memory load ($F=35.7$, $df=1,11$, $p<0.01$). Pair wise comparison of means using Least Significant Different test showed that number of correct code responses was lower at variable assembly order (4.2) as compared to the number of correct code responses were higher at no instruction (4.9) and consistent assembly order (4.8).

Pair wise comparison of means showed that number of correct code responses was lower at above shoulder height (4.5) as compared to elbow height (4.8). Number of correct code responses was also lower at high memory load (4.0) as compared to low memory load (5.4).

No Instruction				Variable Assembly				Consistent			
Elbow height		Above shoulder		Elbow height		Above shoulder		Elbow height		Above shoulder	
Low	High	Low	High	Low	High	Low	High	Low	High	Low	High
5.75	4.33	5.67	4.25	5.58	4.25	5.25	3.83	5.17	3.67	4.75	3.33
0.45	1.67	0.49	1.54	0.90	1.82	0.87	1.53	0.83	1.56	1.29	1.37

Table 7-3: Mean (SD) of correct responses for each of the 12 conditions in assembly task

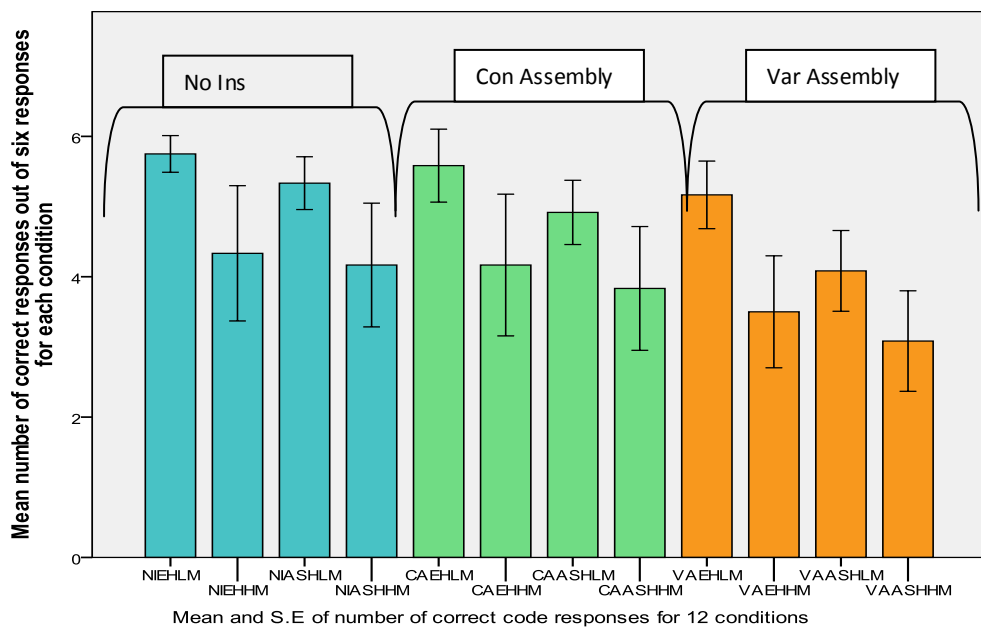

Figure 7-5: Mean number of correct code responses for each of the 12 condition in assembly task

7.4.2.3 Number of fully completed assemblies

A three way (3x2x2) repeated measure ANOVA showed significant effect on number of fully completed assemblies due to two levels of work height ($F=13.61$, $df=1, 11$, $p<0.01$) and two levels of memory load ($F= 13.58$, $df= 1, 11$, $p<0.01$). Pair wise comparison of means using Least Significant Different test showed that Number of fully fastened assemblies was higher at elbow height (32) as compared to the lower at above shoulder height (30). Number of fully fastened assemblies was also higher at low memory load (31.6) and compared to lower at high memory load (30).

No Instruction				Variable Assembly				Consistent			
Elbow height		Above shoulder		Elbow height		Above shoulder		Elbow height		Above shoulder	
Low	High	Low	High	Low	High	Low	High	Low	High	Low	High
33.83	32.50	31.42	30.75	32.25	31.58	31.08	29.00	30.42	31.08	30.67	29.83
1.59	2.68	3.12	2.70	2.93	2.54	2.84	4.07	4.54	3.80	4.23	4.02

Table 7-4: Mean (SD) of completed assemblies for each of the 12 conditions in

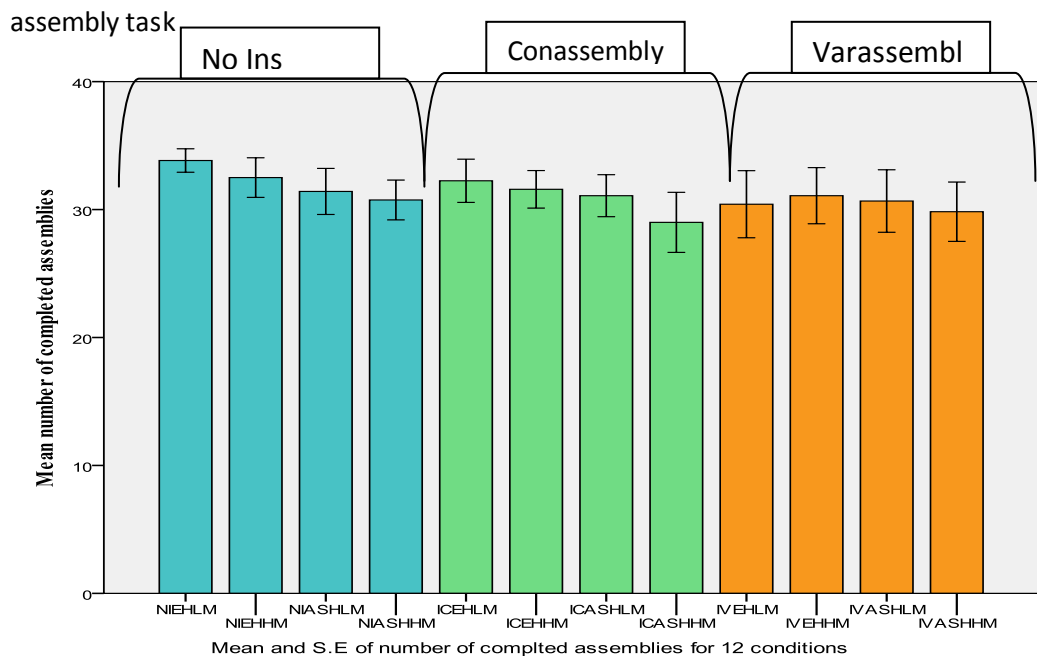

Figure 7-6: Mean number of completed assemblies for each of the 12 conditions in assembly task

7.4.2.4 Number of dropped nuts and bolts

A three repeated measure ANOVA showed significant effects on number of drops due to two levels of work height ($F=52.7$, $df=1, 11$, $p<0.01$) and two levels of memory load ($F= 19.66$, $df= 1, 11$, $p<0.01$). Pair wise comparison of means using Least Significant Different test showed that number of drops was higher at above shoulder height (2.12) as compared elbow height (0.63). Number of drops was also higher at high memory load (1.67) as compared to low memory load (0.97).

ANOVA also showed significant interaction between work height and memory load ($F= 7.58$, $df =1, 11$, $p<0.05$). Post hoc analysis showed that Number of drops was higher at above shoulder height + high memory (2.7) as compared to above shoulder height + low memory (1.5).

No Instruction		Variable Assembly				Consistent					
Elbow height		Above shoulder		Elbow height		Above shoulder		Elbow height		Above shoulder	
Low	High	Low	High	Low	High	Low	High	Low	High	Low	High
0.58	0.75	1.00	2.58	0.25	0.75	2.17	2.50	0.42	0.50	1.42	3.08
0.79	0.75	0.95	1.44	0.62	0.75	1.80	1.31	0.51	1.00	1.51	1.44

Table 7-5: Mean (SD) of number of drops for each of the 12 conditions in assembly task

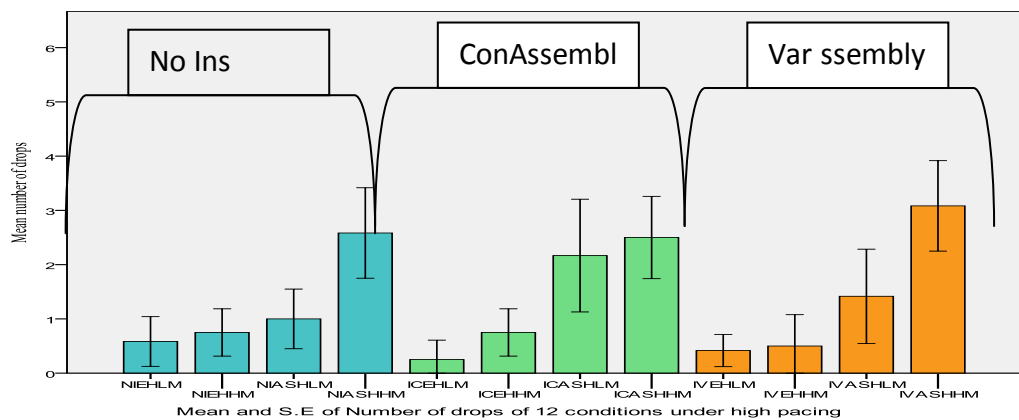

Figure 7-7: Mean number of dropped nuts and bolts for each of the 12 condition in assembly task

7.4.3 Subjective Measures

7.4.3.1 Raw NASA TLX Dimensions

7.4.3.1.1 Perceived mental demand

A three way (3x2x2) repeated measure ANOVA showed significant effects on perceived mental demand due to two levels of work height ($F= 16.25, df=1, 11, p<0.01$) and two levels of memory load ($F= 42.23, df= 1, 11, p<0.01$). Pair wise comparison of means using Least Significant Different test showed that perceived mental demand was higher at above shoulder height (9.9) as compared to elbow height (8.7). Perceived mental demand was also higher at high memory load (11.9) as compared to low memory load (6.7).

No Instruction				Variable Assembly				Consistent			
Elbow height		Above shoulder		Elbow height		Above shoulder		Elbow height		Above shoulder	
Low	High	Low	High	Low	High	Low	High	Low	High	Low	High
4.92	11.67	7.00	12.33	6.08	10.75	6.50	11.67	6.92	12.17	8.92	13.08
2.27	4.14	2.70	3.87	2.39	4.41	2.54	4.85	3.73	3.71	3.15	3.85

Table 7-6: Mean (SD) of perceived mental demand for each of the 12 conditions in assembly task

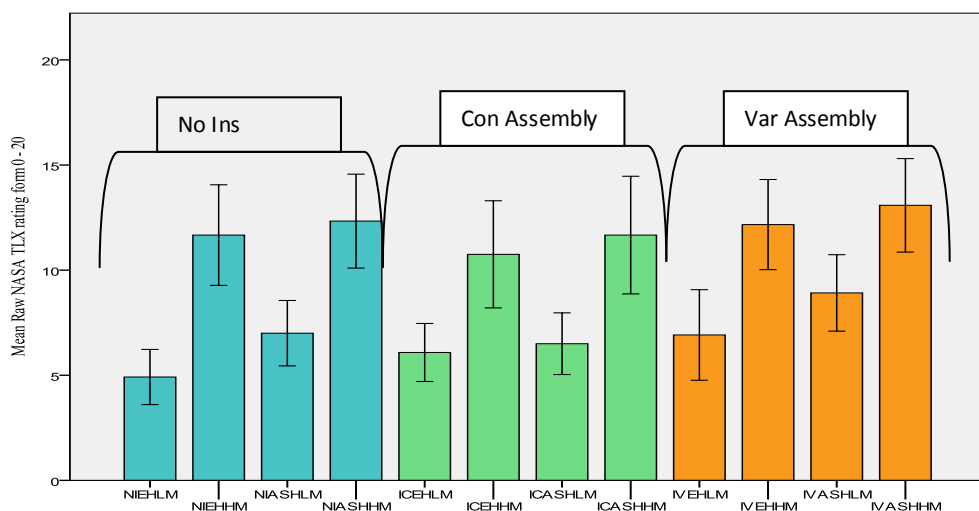

Figure 7-8: Mean and SE of perceived mental demand (0 low and 20 high) 12 conditions in assembly task

7.4.3.1.2 Perceived Physical demand

A three way (3x2x2) repeated measure ANOVA showed the significant effect on perceived physical demand due to two levels of work height ($F= 27.17$, $df= 1,11$, $p<0.01$) and two levels of memory load ($F= 10.32$, $df= 1, 11$, $p<0.05$). Pair wise comparison of means using Least Significant Different test showed that perceived physical demand was higher at above shoulder height (10.93) as compared to elbow height (5.97). Perceived physical demand was also higher at high memory load (8.9) as compared to low memory load (8).

No Instruction		Variable Assembly				Consistent					
Elbow height		Above shoulder		Elbow height		Above shoulder		Elbow height		Above shoulder	
Low	High	Low	High	Low	High	Low	High	Low	High	Low	High
4.67	5.92	9.50	10.17	5.75	7.00	10.58	11.50	6.50	6.67	11.67	12.17
4.03	3.34	5.42	4.63	3.14	3.59	4.12	4.48	3.73	3.11	3.98	4.17

Table Mean 7-7: (SD) of perceived physical demand for each of the 12 conditions in assembly task

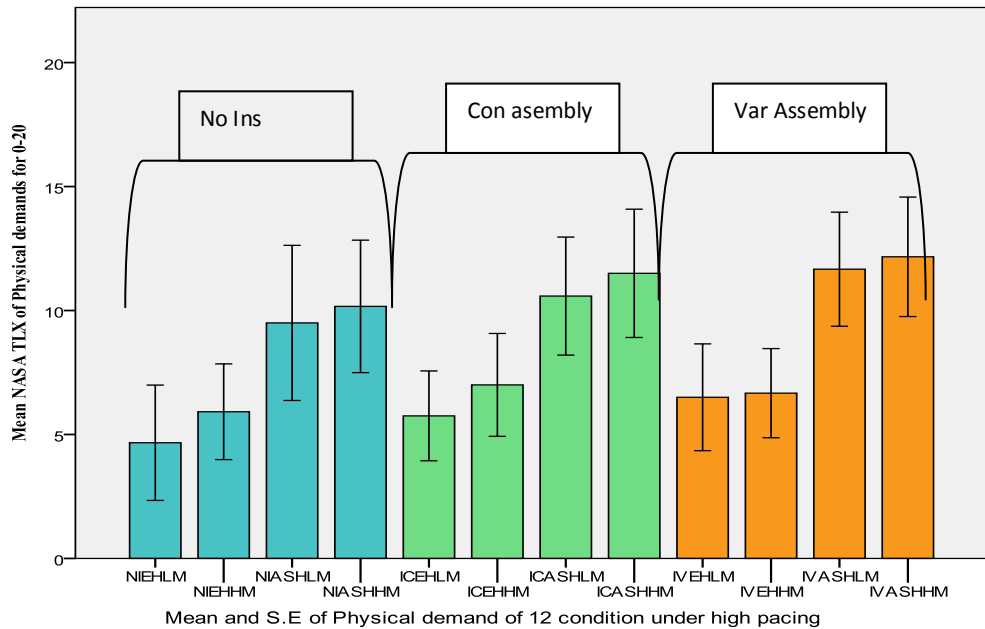

Figure 7-9: Mean and SE of perceived physical demand (0 low and 20 high) 12 conditions in assembly task

7.4.3.1.3 Perceived Temporal demand

A three way (3x2x2) repeated measure ANOVA on perceived temporal demand showed significant effect due to two levels of work height ($F= 39.1$, $df= 1, 11$, $p<0.01$) and two levels of memory load ($F= 31.6$, $df=1,11$, $p<0.01$). Pair wise comparison of means using Least Significant Different test showed that perceived temporal demand was higher at above shoulder height (10.8) as compared to elbow height (8.1). Perceived temporal demand was also higher at high memory load (10.5) as compared to low memory load (8.5).

ANOVA also showed significant interaction between work height and memory load ($F= 6.60$, $df= 1, 11$, $p<0.05$). Post hoc analysis showed that perceived temporal demand was higher at elbow height+ high memory (9.38) as compared to lower at elbow height + low memory (6.9).

No Instruction		Variable Assembly				Consistent					
Elbow height		Above shoulder		Elbow height		Above shoulder		Elbow height		Above shoulder	
Low	High	Low	High	Low	High	Low	High	Low	High	Low	High
5.17	9.42	9.92	11.58	6.83	9.50	10.08	11.58	8.75	9.25	10.42	11.67
2.69	4.64	4.01	3.45	3.83	3.32	3.34	3.96	4.20	4.39	4.74	5.07

Table 7-8: Mean (SD) of perceived temporal demand for each of the 12 conditions in assembly task

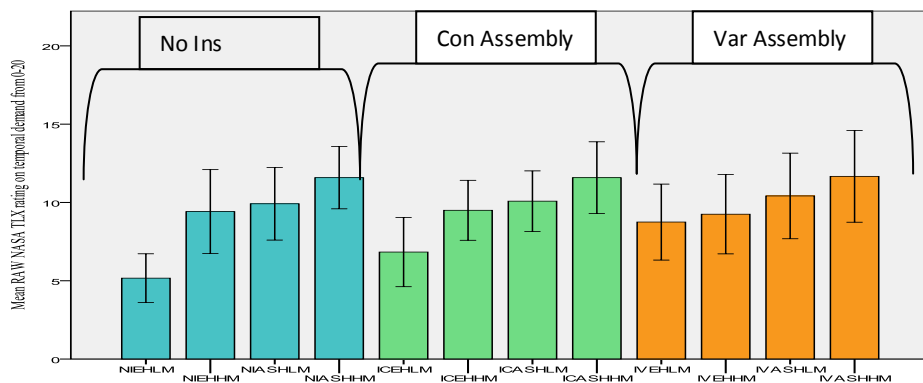

Figure 7-10: Mean and SE of perceived temporal demand (0 low and 20 high) 12 conditions in assembly task

7.4.3.1.4 Perceived Performance

A three way (3x2x2) repeated measure ANOVA on perceived performance showed significant effect due to three levels of assembly order ($F=4.32$, $df=2,22$, $p<0.05$), two levels of work height ($F= 29.4$, $df= 1, 11$, $p<0.01$) and two levels of memory load ($F= 17.33$, $df=1,11$, $p<0.01$). Pair wise comparison of means using Least Significant Different test showed perceived performance was poor at above shoulder height (8.9) as compared to elbow height (7.4). Perceived performance was also poor at high memory load (11.98) as compared to low memory load (9.6).

No Instruction				Variable Assembly				Consistent			
Elbow height		Above shoulder		Elbow height		Above shoulder		Elbow height		Above shoulder	
Low	High	Low	High	Low	High	Low	High	Low	High	Low	High
5.33	8.92	6.75	8.83	5.67	7.67	6.00	11.33	6.33	10.58	9.08	11.67
3.65	4.08	2.49	3.41	3.03	3.60	2.49	4.89	4.19	5.00	3.60	5.38

Table 7-9: Mean (SD) of perceived performance demand for each of the 12 conditions in assembly task

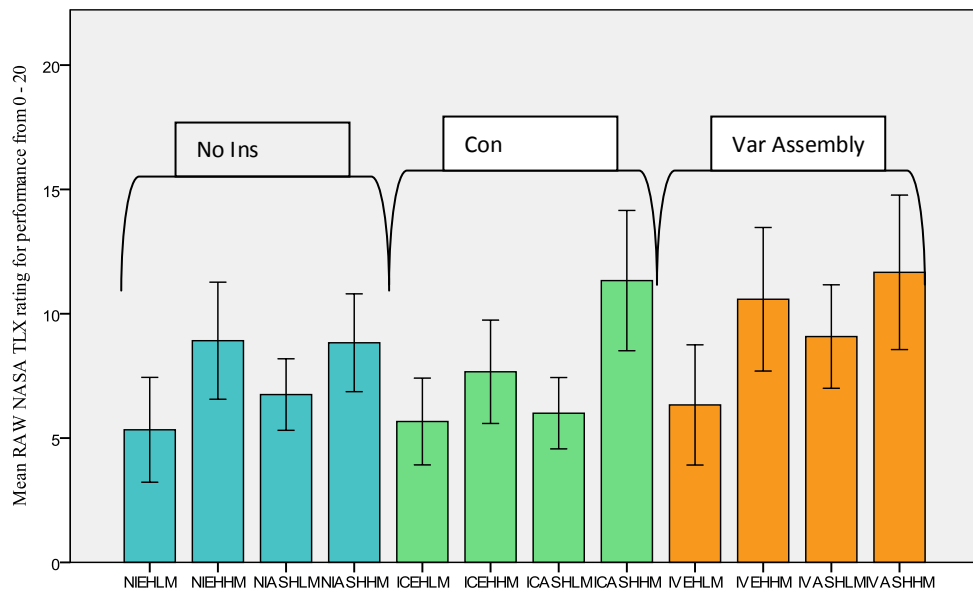

Figure 7-11: Mean and SE of perceived performance (0 perfect and 20 failure) 12 conditions in assembly task

7.4.3.1.5 Perceived Effort

A three way (3x2x2) repeated measure ANOVA on perceived effort showed significant effect due to two levels of work height ($F= 17.48$, $df= 1, 11$, $p<0.01$) and two levels of memory load ($F= 18.12$, $df=1,11$, $p<0.01$). Pair wise comparison of means using Least Significant Different test showed perceived effort was high at above shoulder height (11.7) as compared to elbow height (9.77). Perceived effort was also high at high memory load (11.9) as compared to low memory load (9).

ANOVA also showed interaction between assembly order and memory ($F=4.199$, $df=2,22$, $p<0.05$) and between work height and memory load ($F= 5.82$, $df= 1, 11$, $p<0.05$). Post hoc analysis showed that perceived effort was high at variable assembly + high memory (12.3) that at variable assembly + low memory (9.6). Perceived effort was also higher at elbow height+ high memory (11.5) as compared to lower at elbow height + low memory (8).

No Instruction				Variable Assembly				Consistent			
Elbow height		Above shoulder		Elbow height		Above shoulder		Elbow height		Above shoulder	
Low	High	Low	High	Low	High	Low	High	Low	High	Low	High
7.00	11.83	10.33	12.42	8.75	11.08	11.58	11.83	8.33	11.67	11.00	13.08
4.22	3.61	3.65	3.80	4.03	4.48	3.90	4.97	4.72	3.89	4.41	4.52

Table 7-10: Mean (SD) of perceived effort for each of the 12 conditions in assembly task

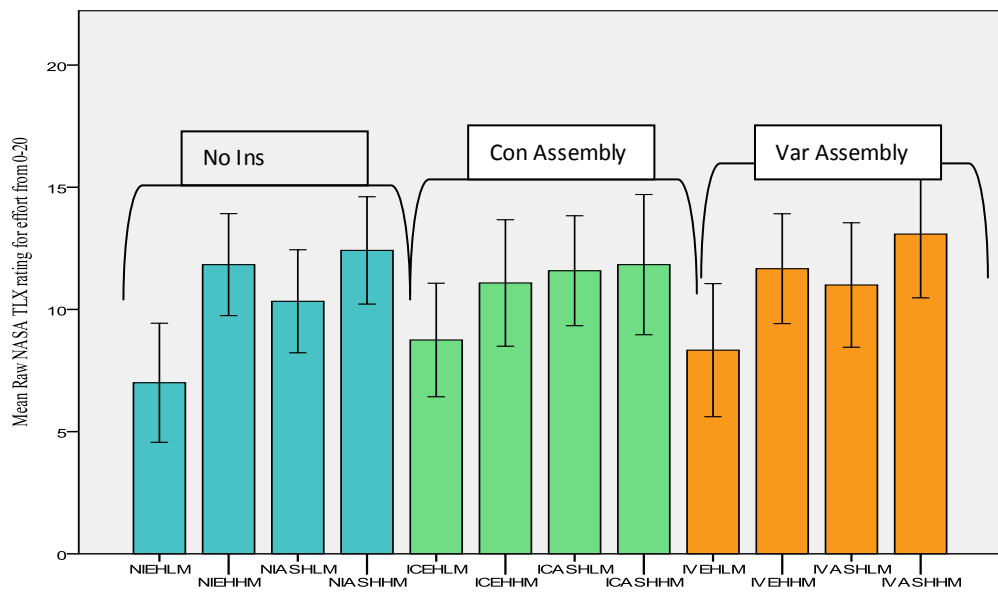

Figure 7-12: Mean and SE of perceived effort (0 low and 20 high) 12 conditions in assembly task

7.4.3.2 Physical well being checklist

Physical well being checklist was used to measure the fatigue and body part discomfort.

7.4.3.2.1 Fatigue

A three way (3x2x2) repeated measure ANOVA in study 3, showed that the fatigue was significantly affected by two levels of work height ($F=11.66$, $df= 1, 11$, $p<0.01$) and two levels of memory load ($F= 5.18$, $df= 1, 11$, $p<0.05$). Pair wise comparison of means using Least Significant Different test showed perceived fatigue was high at above shoulder height (3.31) as compared to elbow height (2). Perceived fatigue was also high at high memory load (3) as compared to low memory load (2.3).

No Instruction				Variable Assembly				Consistent			
Elbow height		Above shoulder		Elbow height		Above shoulder		Elbow height		Above shoulder	
Low	High	Low	High	Low	High	Low	High	Low	High	Low	High
1.33	1.83	1.83	2.33	1.58	2.25	3.67	4.42	1.92	3.42	3.75	3.92
2.46	2.89	2.59	3.11	2.87	3.36	3.28	3.68	3.15	3.78	3.47	3.65

Table 7-11: Mean (SD) of perceived fatigue demand for each of the 12 conditions in assembly task

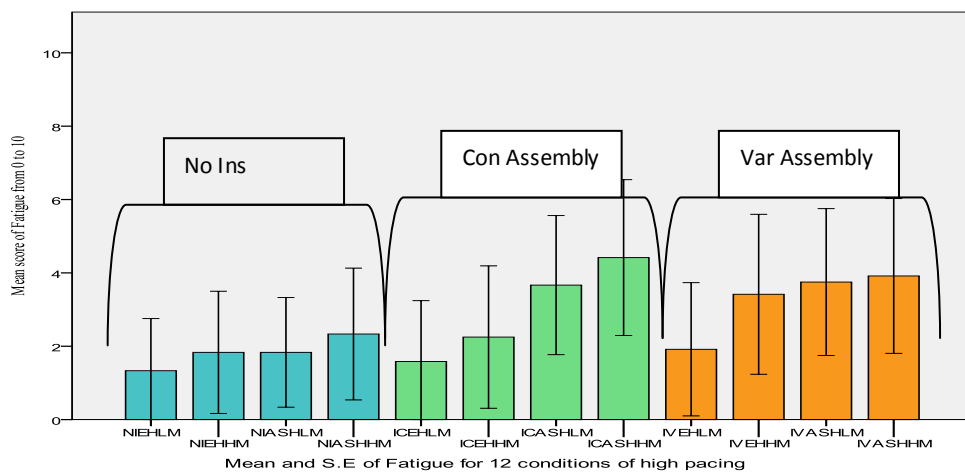

Figure 7-13: Mean and SE of perceived fatigue (0 low and 20 high) 12 conditions in assembly task

7.4.3.3 Stress and Arousal

Stress and arousal was measured using the Stress and Arousal adjective sheet. Mauchly's test indicated that the assumption of sphericity had been violated, $\chi^2(2) = 8.33, p = 0.015$. Therefore, degrees of freedom were corrected using Greenhouse Geisser estimates of sphericity ($\epsilon = 0.686$). Repeated measure ANOVA showed a significant three way interaction between assembly order x work height x memory load on perceived stress levels ($F = 5.4, df = 2, 22, p < 0.05$).

No Instruction		Variable Assembly				Consistent					
Elbow height		Above shoulder		Elbow height		Above shoulder		Elbow height		Above shoulder	
Low	High	Low	High	Low	High	Low	High	Low	High	Low	High
52.83	49.83	51.25	47.75	51.75	48.25	44.58	47.83	48.42	47.17	47.00	47.00
6.03	7.28	6.11	5.96	3.67	7.63	8.81	11.31	7.48	9.27	9.90	10.01

Table 7-12: Mean (SD) of perceived stress for each of the 12 conditions in assembly task

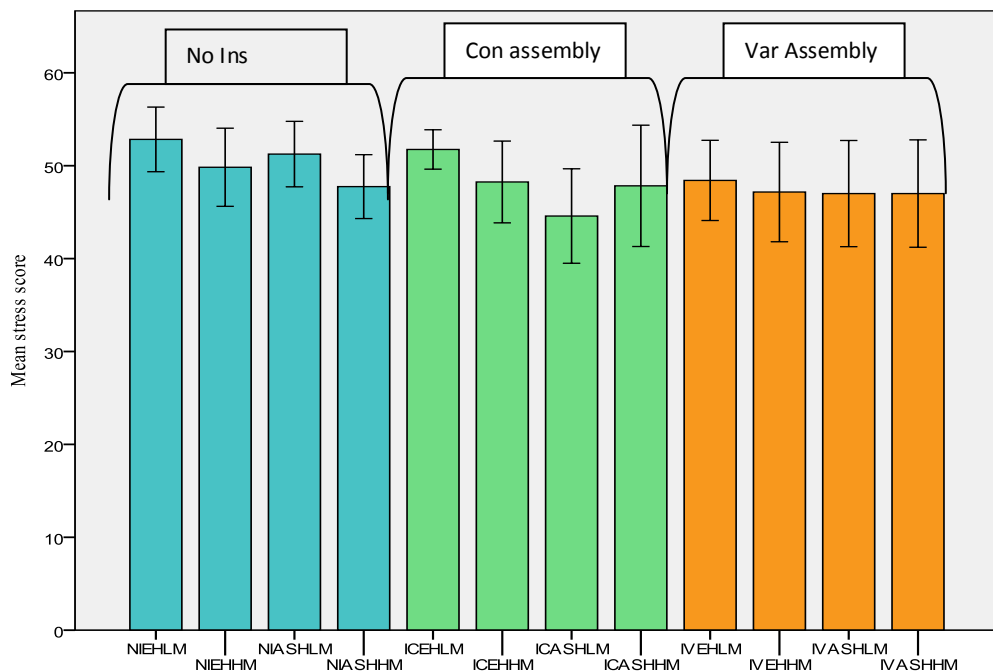

Figure 7-14: Mean and SE of perceived stress for 12 conditions in assembly task

7.4.3.3.1 Arousal

A three way (3x2x2) repeated measure ANOVA in study 3, showed that the arousal was significantly affected by two levels of work height ($F=7.34$, $df= 1, 11$, $p<0.01$). Pair wise comparison of means using Least Significant Different test showed that arousal was high at elbow height (21.2) as compared to above shoulder height (20).

ANOVA also showed significant interaction between assembly order and work height ($F= 6.36$, $df= 2, 22$, $p<0.05$). Post hoc analysis showed high arousal at no instruction assembly+ elbow height (20.14) as compared to arousal was low at no instruction assembly + above shoulder height (17.4).

No Instruction				Variable Assembly				Consistent			
Elbow height		Above shoulder		Elbow height		Above shoulder		Elbow height		Above shoulder	
Low	High	Low	High	Low	High	Low	High	Low	High	Low	High
20.50	20.33	16.50	18.42	21.50	21.08	22.08	21.50	21.00	23.33	21.58	21.58
6.10	5.84	4.46	5.99	6.17	6.37	6.22	6.64	5.89	6.58	6.07	7.20

Table 7-13: Mean (SD) of perceived stress for each of the 12 conditions in assembly task

7.5 Main findings of study 3

The particular objective of study 3 was to investigate in depth the effects of cognitive aspects (assembly order and memory load) on physical load. Table 7-14 and 7-15 present the summary results of objective and subjective measure respectively. The highlighted values show the significant effects. Overall from study 3, it was found that;

- Almost every objective measure, which includes assembly time, number of completed assemblies, number of correct responses and number of drops, was affected by above shoulder height and high memory load. Number of correct code responses was also affected by variable assembly.
- Similarly, raw TLX dimensions including perceived fatigue and arousal were also affected by above shoulder height and high memory load.
- Various interactions between assembly variability and memory load and between work height and memory load were found to be significant.

Independent variable	Objective measures			
	Assembly time (SECONDS)	Number of correct code responses	Number of fully completed assemblies	Number of dropped nuts and bolts (out of 36)
Assembly order df(2,22)	F=3.41	F=14.72** NI & CA>VA	F= 3.556	F=0.347
WH df (1,11)	F=24.23** ASH>EH	F=5.5* EH>ASH	F=13.614** EH>ASH	F=52.7** ASH>EH
ML df (1,11)	F=5.67* HM>LM	F=35.7** LM>HM	F=13.58** LM>HM	F=19.68** HM>LM
AO X WH interaction df (2,22)	F=1.19	F=1.66	F=1.65	F=0.868
AO X ML interaction df (2,22)	F=3.89	F=.031	F=1.24	F=2.62
WH X ML interaction df (1,11)	F=0.450	F=1.90	F=1.54	F=7.01* ASH+HM>ASH+LM
AO X WH X ML interaction df (2,22)	F=0.278	F=0.309	1.66	F=1.64

Table 7-14: Summary of the ANOVA s for objective measures

*p<0.05, **p<0.01 AO- Assembly order, WH- Work height, ML- Memory load

NI-No instruction, CA-Consistent Assembly, VA-variable Assembly, EH, Elbow height, ASH, Above Shoulder height, LM-Low memory, HM-High memory

Independent variable	Dependent variable							
	NASA TLX rating					PWC	Stress & Arousal scores	
	Mental demand	Physical demand	Temporal demand	Performance	Effort	Fatigue	Stress	Arousal
Assembly order df(2,22)	F=2.50	F=2.26	F=0.621	F=3.83	F=0.333	F=2.75	F=2.07	F=3.78
WH df (1,11)	F=16.25** ASH>EH (10.0>8.7)	F=25.93** ASH>EH (10.93>6.08)	F=39.18** ASH>EH 10.87>8.1	F=24.13** ASH<EH 8.94>7.4	F=17.48** ASH>EH 11.7>9.77	F=11.66** ASH>EH 3.31>2.0	F=3.67	F=7.34* EH>ASH 21.29>2..27
ML df (1,11)	F=42.23** HM>LM 11.9>6.7	F=7.22* HM>LM (8.9>8.1)	F=31.6** HM>LM 10.5>8.5	F=17.33** HM<LM 11.98>9.5	F=18.12** HM>LM 11.98>9.50	F=5.18* HM>LM 3.0>2.34	F=3.27	F=0.915
AO X WH interaction df (2,22)	F=1.10	F=0.592	F=1.26	F=0.845	F=0.049	F=2.31	F=1.43	F=6.36* NI+EH>NI+ASH
AO X ML interaction df (2,22)	F=1.52	F=1.52	F=4.009* NI+HM>NI+LM (10.5>7.5)	F=0.407	F=4.199 VALM+VAHM>NILM +NIHM	F=0.150	F=2.69	F=1.12
WH X ML interaction df (1,11)	F=2.42	F=0.139	F=6.60* EH+HM>EH+LM (9.3>6.9)	F=0.012	F=5.82* EH+HM>EH+LM 11.52>8.02	F=0.752	F=4.85	F=0.043
AO X WH X ML interaction df (2,22)	F=1.39	0.211	1.94	F=4.075	F=0.553	F=0.689	F=5.44	F=1.092

Table 7-15: Summary of the ANOVA s for Subjective measures

*p<0.05, **p<0.01 AO- Assembly order, WH- Work height, ML- Memory load

NI-No instruction, CA-Consistent Assembly, VA-variable Assembly, EH, Elbow height, ASH, Above Shoulder height, LM-Low memory, HM-High memory

7.6 Discussion

The overall aim of the research was to investigate the effects of pacing on the quality of performance and subjective responses, and to determine whether there was an interaction between physical and cognitive demands.

The findings showed that the assembly order, work and memory load affected the assembly time and number of correct code responses. Above shoulder height and high memory load also affected number of completed assemblies and number of dropped nuts and bolts. However, assembly order did not affect the number of fully completed assemblies. Overall, it revealed that the quality of performance deteriorated at above shoulder height, and that this is further affected by high mental demand. Also, study 3 found some evidence of cognitive demands having an effect on objective physical performance, with participants showing higher assembly times, fewer completed assemblies and more dropped bolts at higher memory load. This demonstrates that objective assembly performance can be negatively affected by other forms of cognitive demand.

One of the issues with Study 2 was that it introduced higher mental demands as an 8-digit code, and as variable assembly simultaneously. Study 3, by comparing 6 digit and 8 digit code during different assembly order, showed an interesting finding that the variable assembly order was affected by both 6 and 8 digit code. This may also have a direct implication on assembly lines involving mixed workload (physical and cognitive), being processed with variety of products and, more importantly, under high Takt time (Bukchin et al., 2001).

Above shoulder height and high memory load affected all the 5 dimensions of NASA TLX work load. However, study 2 did not show an effect of work height

and memory load on all the 5 dimensions. This may have been due to constant memory load (8-digit) for all the condition, which made the task highly mentally demanding for all conditions. The significant effects on the 5 dimensions of NASA TLX due to above shoulder height and high memory load revealed that the cognitive task components affected the perceived workload as well as objective performance. The significant effect of work height on subjective mental demand support the studies conducted by (DiDomenico and Nussbaum, 2008, Basahel et al., 2010, Perry et al., 2008). However, this study has also shown the effect of work height as a physical demand on objective measure of cognitive load in that the number of correct code responses reduced at above shoulder height. Finding such an effect of physical demand on objective and subjective measures confirms the relation between physical and cognitive demands. However, future studies are needed further investigate such effect using different methods.

Furthermore, the significant effects of memory load on perceived mental demand, perceived physical demand, perceived temporal demand, perceived performance and perceived effort were also the interesting findings, which confirmed that memorising 8 digit code during the physical performance was highly demanding. It was more difficult during variable assembly and at above shoulder height, which the highest demanding condition in this study. Therefore, careful consideration is necessary while designing the production system that involve complex task at different heights.

Perceived fatigue is found to be significantly affected by work height and memory load in study 3. However, in study 1 and study 2, perceived fatigue was not found to be significantly affected, and previous studies have also showed no significant effect on perceived fatigue due to high pacing and work height (Garg et al., 2006). The effect in study 3 is might be because of working for 3 hours and all conditions were performed under high pacing and

memorising the code during the performance. However, order was varied across the study, so this suggests that a cognitive factor (memory load) can increase perceived fatigue (this was also found for the physical demand factor in NASA TLX).

The results of study 3 discussed above, have shown significant effects of assembly order, work height and memory on the objective and subjective measures. The results have further been discussed from the theoretical perspective, considering Armstrong's dose-capacity model and Wickens' multiple resource model. For Armstrong model, the evidence of the effect of high workload on the objective measure of performance shows that workload can act as an external loading factor that affects performance in the same way that physical factor such as work height. Also, for Wickens, memory load has an effect on objective performance. This means that the same resources are used by the memory load and by assembly tasks.

Chapter 8 (discussion) further discusses in detail about the theoretical understanding of the results through different stages of Armstrong and Wickens multiple resource model.

7.1. Summary

The particular objective of this study was to investigate the cognitive aspects of task (assembly order and memory load) on the physical load. The results of this study have shown the significant effect of cognitive demands on physical performance at objective measures and subjective measures and vice versa as discussed above. Chapter 8 discusses all of the results from studies 1, 2 and 3 together.

8 Discussion

8.1 Introduction

This research aimed at investigating the effects of physical and cognitive demands on task performance and subjective responses in simulated assembly tasks representing typical workstation activities in current lean manufacturing systems. In addition to exploring the effects of physical and cognitive demands per se, a main objective of the research was to assess any interaction effects between physical and cognitive demands on the experimental measures.

Analysis of the literature on assembly tasks in lean manufacturing and its implications on working conditions identified physical and cognitive issues related to work task and work pace demands. More specifically, examination of these issues under task pacing condition induced for example by Takt time, a lean manufacturing tool, was selected for further analysis. Literature analysis and observations made during visits to manufacturing industries were used to identify typical physical and cognitive issues related to Takt time during the assembly operations in a moving assembly line. The assembly operations involved repetition tasks, awkward postures, selecting the correct part for the product and time pressure, which resulted in physical and cognitive stresses. Laboratory experiments were carried out to further investigate the effects of Takt time on quality of performance and more specifically to determine whether there is an interaction between physical and cognitive demands.

Three laboratory studies were carried to achieve the research objectives. A simulated task was designed to represent activities that had been observed in industry. Individual elements of the task had been studied in previous research: for example, research has been conducted on pacing (Bosch et al.,

2011), work at shoulder height (Ikuma et al., 2009; Sood et al., 2007) and memorising (working memory) (Miller, 1952). However, no previous studies had examined the interaction effects of cognitive and physical demands under different conditions of work pacing.

At the time when the experimental studies were conducted some studies were reported in the literature showing evidence of interaction between physical and cognitive demand (DiDomenico et al., 2008), and suggested that perceived mental demand increased by introducing the physical demand (DiDomenico et al., 2008 and Perry et al., 2008).

The present research aimed to further investigate these relationships in more detail with the prediction that there physical demand would affect objective cognitive load. This research has confirmed the similar relationship between physical and perceived mental demand as shown by DiDomonico (2008) and Perry (2006) and also found interesting effects of physical demand on objective cognitive load and subjective responses. These are discussed in detail below.

8.2 Objective measures

This section discusses the results achieved from study 1, 2 and 3 on the objective measures. Three independent variables (pacing / Takt, work height and memory load / assembly order) were used in all three studies. The results of each independent variable on objective measures are discussed separately in detail.

8.2.1 Effect of pacing on the objective measures

Table 8-1 shows a summary of the results in which different f levels of pacing had a significant difference on objective measures. The detail of each of the significance effect is discussed in the following sections.

	Pacing levels	Assembly time Mean (S.D)	Number of completed	Drops	Correct responses
Study 1	Assembly task (No Instruction) at No, Low and high pacing	x	X		
Study 2	Assembly task (variable and consistent order) at Low & high pacing	x	X		
Study 3	Assembly task (Variable & consistent order) at high pacing				x

Table 8-1: Effects of pacing/ Takt levels on objective measures

With reference to the literature discussed in chapter 2 and chapter 4, more specifically on effect of pacing on the quality of performance, most of the literature has shown negative impact of high pacing on the quality of performance and working conditions. For example, a study by Schmidt (1994) found that working at a higher speed would lead to lower accuracy of target. Bosch et al., (2011) also found quality errors due to high pacing. Lewchuck (1996) showed that the number of errors increased due to high Takt time. The results of the present research have confirmed the evidence of negative effects of high pacing on the quality of performance / objective measures. AS shown in Table 8-1, the assembly time was affected by high pacing and number of completed assemblies also reduced at high pacing.

Studies 2 and study 3 were modified from study 1 to increase the demands of the cognitive task in the experiment, and the nature of assembly task was changed to more realistically represent a mixed model assembly line and single model assembly line as discussed in chapter 6. Also the memory load was increased to 8 digits in study 2. In study 3, the effect of assembly order on the number correct code responses identified an interesting effect as it showed that number of correct code responses reduced at variable assembly order as compared to no instruction assembly and consistent assembly. Also in study 3, all the conditions were performed under high pacing conditions. This further gives evidence that the number of errors increased due to increase in complexity of task.

8.2.2 Effect of work height on the objective measures

Table 8-2 showed the significant effects of work height on objective measures for study 1, study 2 and study 3. Previous studies research has however, shown that the performance suffered while working at above shoulder height as the number of drops increased more (Sood, et al., 2007). Therefore, it was

hypothesised that the two levels of work height would cause significance effects on objective measures.

	Work height	Assembly time Mean (S.D)	Number of completed	Drops	Correct responses
Study 1	Elbow height and Shoulder height	X		x	
Study 2	Elbow height and Shoulder height	X	X	x	
Study 3	Elbow height and Shoulder height	X	X	x	X

Table 8-2: Effects of work height levels on objective measures

Working at above shoulder height has been widely studied in both field and laboratory work (Sood et al., 2007; Ikuma et al 2009). The literature review showed that, whilst considerable research is available on musculoskeletal disorders, quality errors etc in assembly operations, few studies have examined the effects of physical and cognitive demands. The present study compared the two levels of work height; elbow height (lower arm parallel to the ground) and above shoulder height (above arm parallel to the ground) during simultaneous performance of physical and cognitive demanding task. As can be seen from table 8-2, all the three studies found a significance effect of work height on assembly time, number of completed assemblies, number of dropped nuts and bolts and number of correct code responses. All these effects were due to working above shoulder height. This suggests that working above shoulder height is more demanding than working at elbow height. However, a previous study by Sood et al., (2007) considered above shoulder height (above arm parallel to the ground) as normal posture while comparing it with two high elevated postures.

Furthermore, the effect of work height on number of correct code responses was an interesting finding that stated that the number of correct code responses reduced at above shoulder height. This further shows the relationship between physical and cognitive demands.

8.2.3 Effect of memory on the objective measures

Table 8-3 shows the results of the levels of memory load on objective measures. As already mentioned, the cognitive task in study 2 and study 3 were modified based on the results achieved from the study 1, which was found to be less cognitively demanding. Study 2 was made more cognitively demanding by increasing the size of code and the simple assembly task was also changed to variable assembly and consistent assembly. Study 3 was further modified by combining the essential components of study 1 and study 2 in order to analyse the cognitive aspects physical performance in detail. Therefore results are discussed based on the modification in assembly task.

	Memory load	Assembly time Mean (S.D)	Number of completed	Drops	Correct responses
Study 1	Low and High				
Study 2	Assembly task (variable and consistent order) at Low & high pacing	X	X		X
Study 3	Low and High	X	X	X	X

Table 8-3: Effects of Memory on objective measures

The involvement of memory load as a cognitive demand in the current studies was based on observations in an automobile industry. It was observed that the operators were getting the code from the automobile at workstation, memorised the code and walked to the shelf to pick the similar code part for the shelf. It was expected that mental load and mental demands might increase in the case of reduced Takt time (if customer demands increases).

As can be seen from table 8-3, study 1 showed no effect of memory load on the any of the objective measure, which proved that the study 1 was less cognitively demanding as the participant were able to memorise the 4 digit (low memory) and 6 digit (high memory load) during the physical performance of simple assembly task, even under high Takt time. This further supports the evidence of the previous research that people can memorise up to 7 digits in a short tem memory (Miller, 1952).

By increasing the cognitive demands in study 2 and study 3 to a higher memory load level (increased to 8 digit) and at assembly task level (variable assembly and consistent assembly), both study 2 and study 3 found significant effects on almost all the objective measures. However, the results for study 2 and study 3 are different due to difference in cognitive demands. Study 2 showed that assembly time, number of completed assemblies and number of correct code responses reduced at variable assembly order. Since the memory load (8 digit) was kept same for all the conditions, therefore it was difficult to analyse the effect of memory on the performance. Hence, study 3 was modified by combining aspects of study 1 and study 2 in order to completely analyse the effect on memory load on the quality of performance. Study 3 showed the effects of memory load on all the objective measures, which further confirmed that high memory, especially 8-digit code was difficult to memorise during simultaneous performance of physical and cognitive demanding task. This indicates the cognitive demands such as

memory load, or instructions, memorising parts etc., can have a negative effect on performance.

8.3 Subjective Measures

Three subjective methods were used to analyse the subjective responses. NASA TLX ratings, Physical well being check list (fatigue and discomfort) and stress and arousal score. The perceived responses of each subjective measurement are discussed separately in detail in the following sections.

8.3.1 Effects of pacing on the dimension of NASAL TLX

Table 8-4 shows the significant results of NASA TLX rating achieved at pacing levels.

	Pacing levels	Mental	Physical demand	Temporal	Performance	Effort
Study 1	Assembly task (No Instruction) at No, Low and high pacing			x	x	x
Study 2	Assembly task (variable and consistent order) at Low & high pacing	x		x	x	x
Study 3	Assembly task (Variable & consistent order) at high pacing	x				

Table 8-4: Effects of pacing/ Takt levels on NASA TLX dimensions

As can be seen from table 8-4, study 1 did not show significant effect of pacing on mental demand and physical demand. These results further confirmed that study 1 was less demanding. However, study 1 showed significant effects of pacing on temporal demand, performance and effort. This was due to high pacing / Takt as the participant had to finish the task in 60 seconds, which then resulted in increased temporal demand, poor performance and increased effort.

Study 2 showed significant effects of pacing on perceived mental demand. It was found that the perceived mental demand was higher at high pacing as compared to the perceived mental demand was lower at low pacing.

In study 3, all the conditions were performed under high pacing. Therefore, the analysis was carried out on three levels of assembly order. A three way ANOVA with repeated measure design showed significant effect of pacing on perceived mental demand. It was found that the perceived mental demand was higher at variable assembly order as compared to no instruction assembly and consistent assembly order.

8.3.2 Effects of work height on NASA TLX dimensions

Table 8-5 shows the significant results of NASA TLX rating achieved at work height.

	Work height	Mental	Physical demand	Temporal	Performance	Effort
Study 1	Elbow height and Above shoulder height	x	X	x		x
Study 2	Elbow height and Above shoulder height		X			x
Study 3	Elbow height and Above shoulder height	x	X	x	X	x

Table 8-5: Effects of work height on NASA TLX responses

Working at above shoulder height was considered to more demanding as compared to working at elbow height. Objective results of current studies showed that the above shoulder height was more demanding as was affected by assembly time, number of completed assemblies and number of drops. Previous research has also shown the quality and productivity issues while working at above shoulder height. Therefore it was predicted that NASA TLX rating would be affected by above shoulder height.

Results of all three studies have shown significant effects of work height on subjective responses of NASA TLX dimensions. Perceived mental demand, physical demand, temporal demand and effort were affected by above shoulder height in study 2. Whereas, perceived physical demand and perceived effort were affected by above shoulder height in study 2. And in study three all the five dimensions of NASA TLX were affected by above shoulder height. this showed that the It was found that the perceived

physical demand was higher at above shoulder height as compared to perceived physical demand was lower at elbow height.

The interesting finding was the effect of work height on perceived mental demand, which supports the evidence of the previous studies by Didominico (2008 and 2011) that stated the mental demand increased by introducing physical demand.

8.3.3 Effects of memory load on NASA TLX dimensions

Table 8-6 shows the significant results of NASA TLX rating at in each study.

	Memory load	Mental	Physical demand	Temporal	Performance	Effort
Study 1	Low and High	x		X	x	x
Study 2	8 digit memory + assembly order	x				x
Study 3	low and high memory	x	X	X	x	x

Table 8-6: Effects of memory on NASA TLX responses

Generally every task involves cognitive process to perform physical or cognitive demanding task. However, by adding extra cognitively demanding task may result in increased mental workload. Giving arithmetic problems during physical performance, memorising the number in short term are the examples of extra cognitive demanding task. Similarly memorising the code during physical assembly of fastening nuts and bolts in the present study was assessed to investigate the effect of cognitive aspects on physical performance.

Table 8-6 shows the clear effects of two levels of memory load on the subjective responses on NASA TLX. Perceived mental demand, temporal demand, performance and effort were significantly affected by high memory load in study 1. Whereas, study 2 was modified with two aspects of cognitive

load; the first procedural in assembling the component in particular order and the second memorising the 8-digit code during the assembly task. Overall study 2 was found to be high cognitive demand and the assessment of memory load on performance was not clearly understood. However, results clearly showed that the perceived mental demand and perceived effort increased due to variable assembly order.

Furthermore, study 3, which was the combination of study 1 and study 2, showed the effects of both aspect of cognitive aspects (high memory load and variable assembly) on perceived mental demand, physical demand, temporal demand, performance and effort. The interesting finding was the effect of memory load on physical demand, which showed that the perceived physical demand increased due to high memory load.

8.3.4 Fatigue

A physical well being checklist was used to measure the fatigue. The measurement was carried out on 10-point scale ranging from 0 as extremely energetic and 10 as extremely tired or fatigued.

Study 1 and study 2 showed no effect of pacing, work height and memory load on perceived fatigue. These results were similar to previous studies conducted by (Ikuma, 2009; Garg, 2006, Bosch) that showed no sign of perceived fatigue while working at high pacing conditions and above shoulder height.

Study 3 showed significant effect of work height and memory load on perceived fatigue. It was surprising at first as previous two studies did not show perceived fatigue due to effect of pacing, work height and memory

load. However, the reason for increased fatigue could be that all the conditions were performed under high pacing conditions (i.e 60 seconds to finish the assembly) for 3 hours, whereas, in the previous two studies assembly tasks were performed under no pacing, low pacing and high pacing conditions in study 1 and under low pacing and high pacing conditions in study 2.

8.3.5 Stress and Arousal

The stress and arousal checklist was used to assess the mood during the simultaneous performance of physical and cognitive demanding task at levels of pacing / Takt, work height and memory load.

Study 1 showed no significant effects of pacing, work height and memory load on stress. In study 2, perceived stress and arousal were found to be high at high pacing conditions. These results in study 2 further lead to study 2 more demanding as discussed on previous sections.

8.4 Interactions

Studies have shown significance interactions between the levels of independent variables on objective measures. 7 interactions were found in all three studies. 2 interactions in study 1, 2 in study 2 and 3 from study 3. The important interactions are discussed as below.

8.4.1 Interaction between pacing and work height on number of completed assemblies

Study 1 showed significance interaction between pacing and work height on number of completed assemblies. It was found that the number of completed assemblies was higher at high pacing + elbow height as compared to the number of completed assemblies which was lower at high pacing + above shoulder height. Most of the effects found in study 1 were related to high pacing as participants were able to finish their assemblies in time during no pacing and high pacing conditions. It was found that the participants were

able to finish their assemblies during high pacing conditions. However, not all the participants able to finish the assembly during high pacing conditions (60 seconds). Furthermore, it was also found the elbow height was less demanding than the above shoulder height. Therefore, finding interaction between pacing and work height on number of completed assemblies could be expected.

8.4.2 Interaction between pacing and work height on number of completed assemblies

Study 2 showed the significance interaction between pacing and work height on number of completed assemblies as shown in figure 8-1. It was found that the number of completed assemblies was high at high pacing + elbow height as compared to the number of completed assemblies was lower at high pacing + above shoulder height. This was same interaction found in study 1.

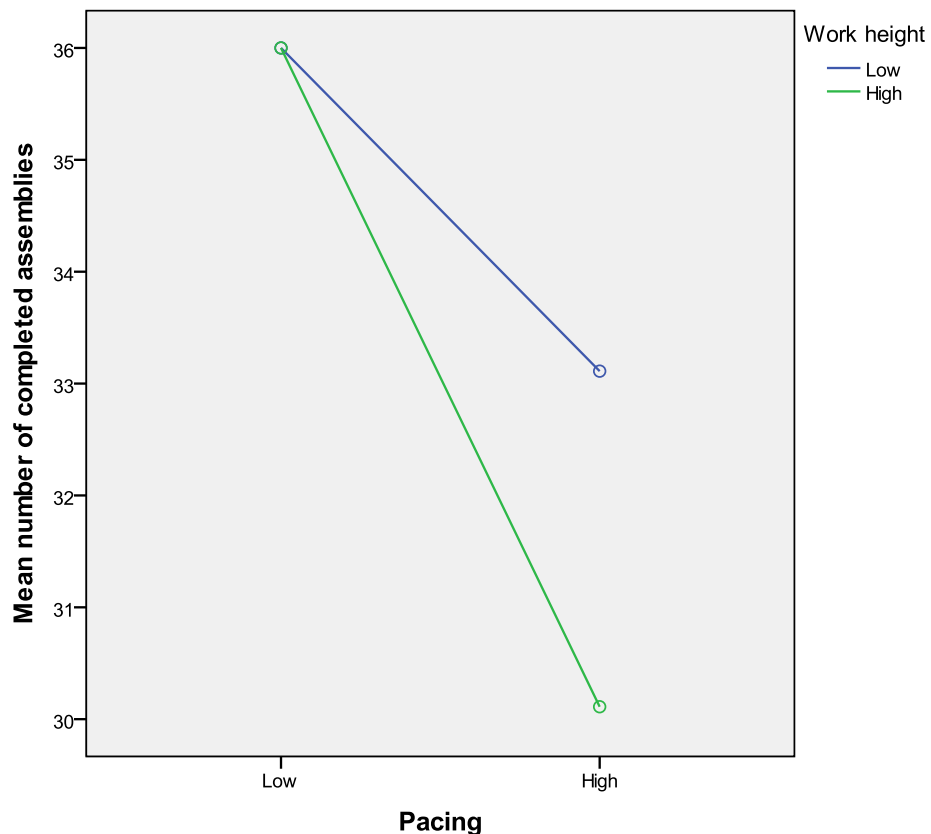

Figure 8-1: Interaction between pacing work height on number of completed assemblies

8.4.3 Interaction between pacing and assembly variability on number of completed assemblies

Study 2 also showed the interaction between pacing and assembly variability as shown in figure 8-2. It was found that the number of completed assemblies was higher at high pacing + consistent assembly order as compared to the number of completed assemblies was lower at high pacing + variable assembly order. Variable assembly and consistent assembly order in study 2 represented the production in mixed model assembly line and single model assembly line. Studies showed that the mixed model assembly line was more demanding due to variety of products being processed through moving assembly line.

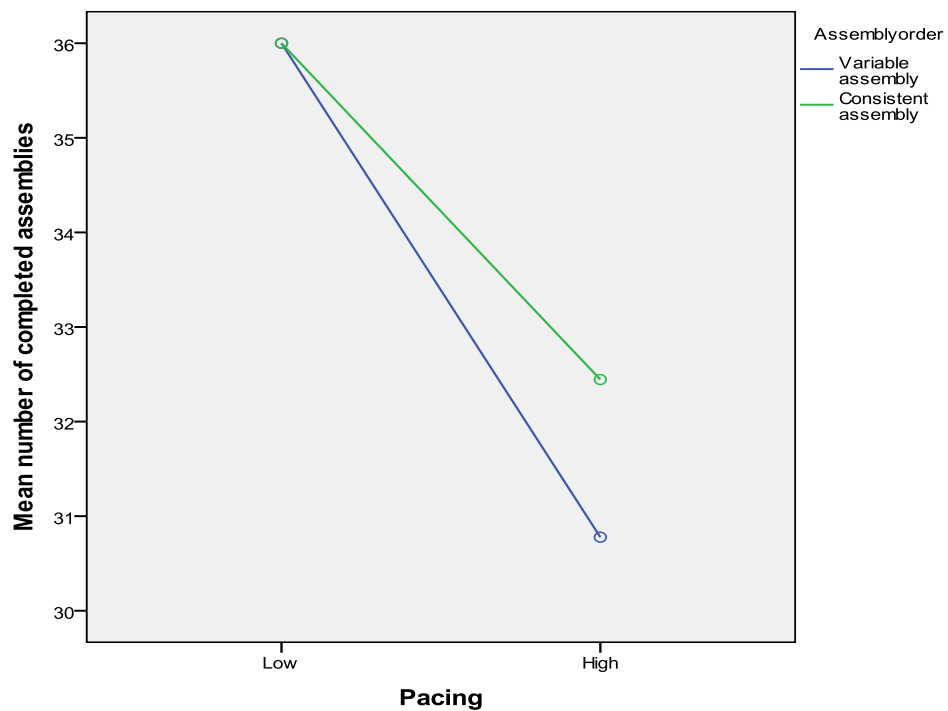

Figure 8-2: Interaction between pacing and assembly order on number of completed assemblies

8.4.4 Interaction between assembly variability and memory load on assembly time

A significant interaction was found between assembly variability and memory load on assembly time. Post hoc analysis showed two interactions between assembly order and memory load.

It was found that the assembly time was higher at no instruction assembly + high memory as compared to the assembly time was lower at no instruction assembly + low memory load (Figure 8-3). This was an interesting interaction as it showed that the assembly task was affected by high memory load (8-digit). However, interaction at no instruction might have occurred due to all participants first performed all no instructions conditions first. Further study is needed to test whether this effect was because there is some aspect of no instruction that effects cognitive load, or whether it is being new to the task that leads to the effect of cognitive load.

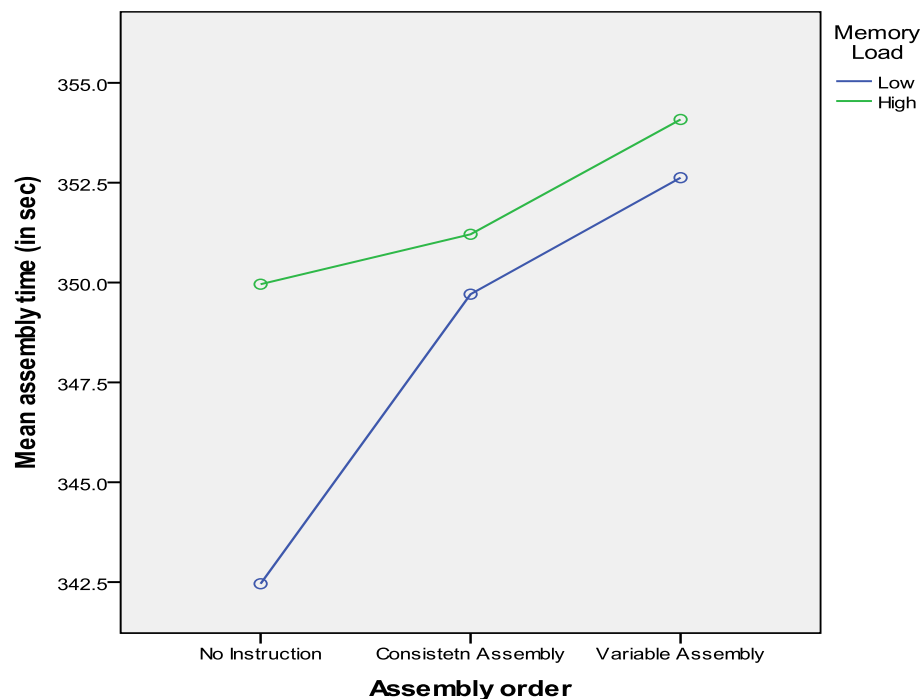

Figure 8-3: Interaction between assembly variability and work height on assembly time

8.4.5 Interaction between work height and memory load on number of dropped nuts and bolts

It was found in study 3 that the number of dropped nuts and bolts were higher at above shoulder height + high memory load as compared to the number of dropped nuts and bolts were lower at above shoulder height + low memory load as shown in figure 8-4.

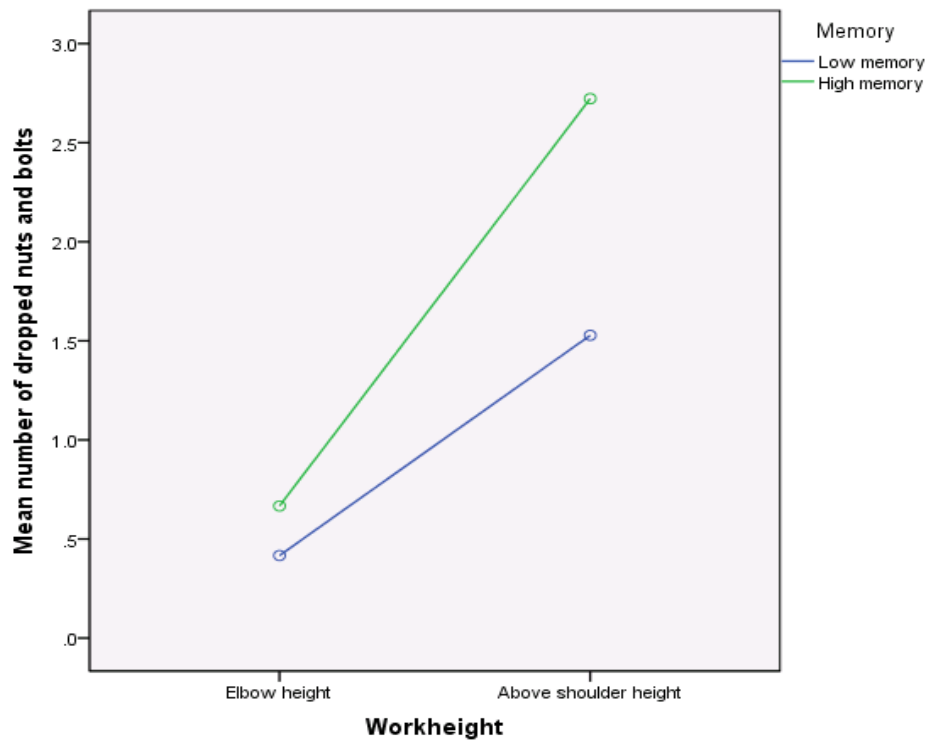

Figure 8-4: Interaction between work height and memory load on number of dropped nuts and bolts

8.5 Theory

This section discusses the experimental results from the theoretical perspective in relation to models described in Chapter 2. Armstrong et al's dose-capacity model (1993) suggests that physical demand (as an external factor) causes disturbance (dose) and, depending upon the capacity, leads to physical and psychological responses. However, the perception of physical and cognitive demands and its effects on objective and subjective

performance during assembly line operation is not well understood. Therefore, this research has considered how the perception of physical and cognitive demands, when performed simultaneously, affects user responses (see table 8 -7).

Table 8-7 demonstrates the understanding on relationship between exposure, dose, capacity and response

	External factors (exposure)	Dose	Capacity	Response	
				Objective	Subjective
Study 1	Pacing/ Takt Work height memory load	Above shoulder height High pacing/ Takt	Frequency of fastening nuts and bolts under different conditions	Assembly time Number of completed assemblies	NASA TLX dimension
Study 2 and Study 3	Pacing Work height Memory load Assembly order	High pacing/ Takt Above shoulder height High memory load Variable assembly (MMAL)		Affected performance by Assembly time Number of completed assemblies Number of correct responses Number of drops Walk time	Workload increased due to NASA TLX dimension Fatigue Stress

Table 8-7: Relationship between exposure, dose, capacity and response

According to Armstrong’s model, physical and cognitive demands will influence response effects, however it is not clear how cognitive and physical factors combine. In the experiments presented in this thesis, study 1 was found to be less demanding. In studies 2 and 3 complexity was increased by changing the fastening task into an assembly order task comparing single model assembly line operation and mixed model assembly line operation (MMAL), and increasing the memory load affected the performance. These studies showed that physical and most interestingly cognitive demands during assembly operation task may act as dose and affect the physical (increased

fatigue) and psychological (NASA TLX dimension and increased stress) performance. Study 3 (which was the combination of study 1 and 2) revealed that the combined load of physical and cognitive demands deteriorated performance due to high pacing, above shoulder height, variable assembly order and memory load, which are the common factors of assembly operations. However, comparing the results of study 1 with study 2 and 3, it was found that working height at above shoulder height in study 2 and 3 has as affected the performance more at both objective (time to perform the task increased, decreased number of completed assemblies, increased number of drops and decreased number of correct code responses) and subjective measures (Workload increased due to NASA TLX dimensions, increased fatigue and stress). Previous research on combined load as mentioned in chapter 2 has however, shown mixed response that the intermediate and high level of physical workload hinder performance (DiDomenico et al., 2008 & 2011). Some found that intermediate levels of physical load facilitate mental task and information processing (Briswalter et al., 2002; Bahasal et al., 2010). Therefore, the results of this research suggest that combined effects of physical and cognitive demands, specifically under high Takt and mixed model assembly line may deteriorate the performance physically and psychologically. However, Armstrong is not clear on how this effect occurs.

The multiple resource model (Wickens, 2004) suggests that the combination of similar task demands may increase workload, but there is a gap in the literature with regard to investigation of how the demands of assembly operations are perceived through different channels and what effects they have on performance and attention resources. MRM mainly focuses on the nature of multiple cognitive tasks (intra modal or cross modal) and how they are processed through the human information processing system (Wickens, 2002 and 2008). This research has however, used physical demands (work height and fastening of nuts and bolts) and multiple cognitive demands

(memory load, assembly order of fastening nuts and bolts) to perform the verbal and visuo-spatial tasks in order to investigate the effects on the performance and attention resources under different pacing/ Takt levels as time is most important factor of task demand. Tasks demand as defined by Wickens (2002) that the proportion between time needed to do a certain task and the time available to perform that task.

All three experimental studies supported the aspect of MRM model, which explains that performance suffers when two tasks use similar resource (intra modal) and performance is better when two task use different resources (cross modal). Study 1 was found to be less demanding, but the multiple cognitive tasks (memory and task demand (fastening of nuts and bolts under pacing/ Takt levels)) as two different tasks seemed to be perceived through different resources. Therefore, performance did not suffer as the participants were able to memorise the code even under high pacing/ Takt conditions.

Study 2 and 3 were therefore, modified to be more cognitively demanding. This leads to perceived workload with physical and multiple cognitive demands when performed simultaneously. The introduction of assembly order of fastening nuts and bolts (representing SMAL and MMAL) as a cognitive demand has put more effort on the task perception and affected the performance during simultaneous performance of physical and cognitive demands.

As stated in Wickens (2002) multiple resource model that resources used during perception and cognition (working memory) are different from the resources used during selection and execution. The findings of this research have supported the Wicken (2002) multiple resource model by revealing that the performance suffered more under high pacing/ Takt conditions due to assembly variability order (representing mixed model assembly line), which

required verbal and visuo-spatial as compared to consistent assembly (representing single model assembly line operation). Consistent assembly order did not require verbal resources. Therefore, participants perceived the task more demands when performed the task at above shoulder height, variable assembly and memory load.

Also, Marras and Hancock (2014) recently proposed a model of interaction, that may be used to understand the effects of physical and cognitive demands on perception. The model (see figure 8-5) presents a holistic approach, which includes the physical environment (e.g., visual conditions, auditory environment, thermal conditions, tactile and haptic information), physical demand (e.g., include strength, energy expenditure, acuity or manipulations, speed or repetition demands, required stability, kinetics and kinematics), cognitive demands (e.g., mental processing, decision making, multitasking, memory and problem solving) and psychosocial environment (e.g., include perceived job demands, decision latitude and control, stimuli received from work). These physical and cognitive general demands seem to have effects on resource capacities during the perception of the task, which might further lead the task to be mentally stressful before performing the task.

The Marras and Hancock (2014) model of physical and cognitive interaction is not specific about the demands that could be thought to have some interaction effects on the physical and cognitive performance. Studies 1, 2 and 3 suggest these demands are working at above shoulder height, fastening task and [memory load and assembly variability as well as pacing/ Takt.

Marras and Hancock (2014) model suggests that the perception of demands comes before actual performance. This is supported by the current research that found that interactions between physical and cognitive demands occur in

subjective work load interactions more than actual performance interactions. There needs to be further studies testing Marras and Hancock (2014) model using the variables of this research.

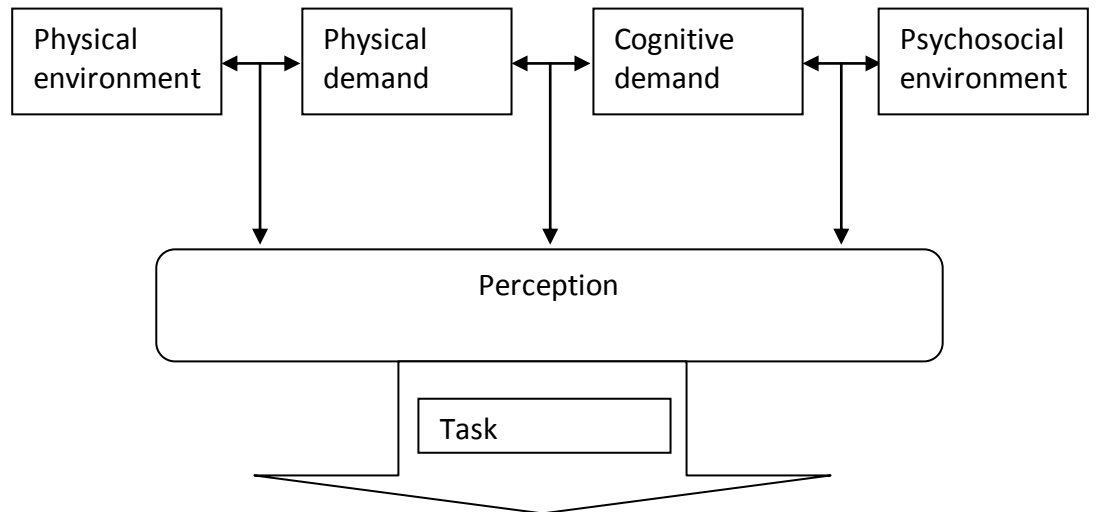

Figure 8-5: Task environment sub-system components (Marras and Hancock, 2014)

8.6 Summary

The main aim of the research was to identify any interaction between physical and cognitive demands resulting from assembly tasks to understand how lean manufacturing tasks may impact on performance and subjective measures. Three experimental studies were conducted on laboratory tasks designed to simulate tasks that were observed within assembly line e manufacturing, in order to investigate three main assembly variables; working height, memory load and pacing. The first study showed that completed assemblies were reduced when performed at higher pacing and while working at above shoulder height. When performed at elbow height 'wait' time increased. The number of components dropped was higher when performed at above shoulder height. Subjective measures (NASA TLX) showed that temporal demand and effort were reported as higher during high pacing. Perceived physical and temporal demand increased when working above shoulder height. One interaction was identified between pacing and working height.

In the second study the experimental design included a mixed model (variable) and single model (consistent) assembly task. Completed assemblies were higher for the consistent assembly task. Subjective measures reported stress as being higher for higher pacing and variable assembly.

The final study combined the variables from the first two studies as well as investigating different levels of memory load. Performance times for variable assembly were longer and resulted in less correct code responses. A higher memory load resulted in a higher performance time and lower correct code responses as well as less completed assemblies. An interaction between working height and perceived mental workload was found. It was also found that memory load affects perceived physical demand.

For industry the findings suggest that in variable (mixed model) assembly different levels of pacing, working height and cognitive demands may affect workers performance both physically and mentally. Demands will be higher when working at variable assembly but also performance will vary where variable and consistent assembly are used together. This work shows the interaction effects for physical and cognitive demand (e.g. DiDomenico (2008) and Perry (2008) do apply to assembly tasks.

9 Conclusion

9.1 Introduction

The research in this thesis was aimed at investigating the effects of physical and cognitive demands involved in an assembly operation task representing a typical moving assembly line while working under different Takt times.

Another aim of this research was to determine whether there was any interaction between physical and cognitive demands in their effects. This chapter restates the main contributions of this research together with recommendations for further work.

9.2 Contribution to aims and objectives

Objective 1: To identify issues related to assembly operations in paced assembly lines

A detailed review of literature on assembly, particularly under paced conditions and mixed model assembly, identified issues related to physical and cognitive demands. These are discussed in detail in chapter 2. The main findings from the literature analysis on lean manufacturing related to physical and cognitive issues were:

- Modern manufacturing through techniques like lean has shown its efficiency in improving productivity and quality. Modern assembly has high repetition due to reduced waiting and walk time as a result of short Takt time (Womack 2009).
- However, lean manufacturing has also shown negative impact on working conditions through high pace, increased pressure on the operator and mixed model assembly (Bosh, 2011; Zhu et al., 2008).
- Physical demands may come from working at shoulder height, high pace and fatigue (Sood et al., 2007; Ikuma et al., 2009)
- Cognitive demands may come from information processing (attention, memory)(Richardson, et al., 2006)

- There is evidence of combined physical and cognitive demands (DiDomenico, 2011; Perry et al., 2008) but there is little evidence yet that this applies to assembly.
- From Armstrong (1993), the perception of physical and cognitive demands (visual, auditory and or spatial) and its effects on objective and subjective performance during assembly operation, lead the operator to perceive the physical and cognitive demands concurrently. Therefore, Armstrong's model offers an understanding of how physical and cognitive external factors in assembly may lead to dose and response.
- MRM suggests that the combination of similar task demands may lead to workload, but this leaves a gap in the literature to investigate how the demands of assembly are perceived through different channels and what effects they have on performance and attention resources.

Field studies (observation and interviews) were carried out to further understand the current status of the impacts of lean manufacturing on working conditions in manufacturing organisations of UK and Europe (through ManuVAR). The detailed analysis of industry observations and interviews is discussed in chapter 3. Visits were carried out to observe assembly operations involving physical and cognitive demands in assembly lines. As literature highlighted the physical and cognitive issues due to reduced Takt time, the main focus during the industry visits was to observe the workstation tasks in order to understand the performance of physically and cognitively demanding tasks under different pacing levels.

The main findings of the field studies related to physical and cognitive demands were:

- Organisations were partly implementing lean manufacturing systems

- During the observation study, which took place between 2009 and 2010, customer demands were not high, resulting in increased Takt time
- Physical demands (awkward postures, carrying heavy weights manually) and cognitive demands (following specified instructions, memorising codes, selecting the right part for the right product) were observed during assembly operations in workstations on the two assembly lines observed.
- Operators were found to wait for the arrival of the next assembly. This because of the high Takt time allowed during the period of the visits and would not always be the case in these, or other, companies.

Objective 2: To investigate the effects of Takt time systems on working conditions during simultaneous performance of physically and cognitively demanding tasks

Three laboratory studies were conducted simulating demands of an assembly task based on the observations made of work on automobile assembly lines. The physically demanding task consisted of fastening nuts and bolts to a plate placed at different work heights. The cognitively demanding task consisted of memorising the product code, where the number of digits in the code varied according to the needs of the particular experiment. Study 2 and Study 3 were modified from the initial design for Study 1 to be more cognitively demanding. Study 2 investigated the difference between working at a mixed model assembly line and at a single model assembly line. Study 3 investigated the effects of physical demand on objective performance and subjective responses. In all experiments, the main objective was to examine how pacing affected work performance and subjective experience.

Study 1 found that high pacing /Takt (set as 60 seconds to perform the assembly task of fastening six nuts and bolts) affected the task performance both objective and subjective responses. This showed that not all the participant were able to finish the assembly in time. Moreover, high Takt also affected the number of completed assemblies and surprisingly affected the walk time also. It was found tha, due to high Takt time, the participant moved faster between the workstation and computer display than no pacing and low pacing/ Takt conditions.

Work height levels also affected the performance as the time to complete the assembly task and the number dropped nuts and bolts were higher at above shoulder height. Time to complete the assembly task affected the perceived raw TLX dimensions. Perceived temporal demand and perceived effort were higher during high pacing/ Takt, and perceived performance was also found to be little poor at high pacing/ Takt.

Study 2, though modified with more complexity, found similar results as in study 1. It was found that the two levels of pacing affected the actual assembly time, number of completed assemblies and walk time, which revealed that participants were unable to finish their assembly task, and fully completed assemblies under high pacing / Takt time of 60 seconds per assembly task. This supported the findings of study 1. It was also found as in study 1 that participant moved more frequently between assembly task and computer display due to high pacing conditions.

Subjective responses (raw NASA TLX) and stress and arousal scores were also affected by pacing, work height and assembly variability. It was found that perceived mental demand, temporal demand, performance and effort were affected due to high pacing/ Takt condition. Perceived stress and arousal

scores were also affected due to high pacing/ Takt, which revealed that the high paced assembly was more mentally demanding.

Similarly variable assembly order affected mental demand, effort and stress. This was an interesting finding that differentiates the level of cognitive demand between variable assembly and consistent assembly.

Study 3 was conducted to analyse more specifically, the effect of physical load on cognitive aspects of workload. It was found that the number of completed assemblies, number of correct code responses and number of drops were affected by working above shoulder height. It was also found that the number of correct code responses was affected by variable assembly order (Mixed model assembly line). Similarly, raw TLX dimensions including perceived fatigue and arousal were also affected by working above shoulder height and high memory load.

Objective 3: To determine whether there is an interaction between physical and cognitive demands in the effects on quality of performance and subjective responses

Previous studies reported in the literature have been conducted to investigate the effects of physical and cognitive demands on performance separately. Some of the studies have shown the effects of physical demand on the cognitive load and cognitive demands on physical load. However, the effects in these studies were not clear, and raised a question as to whether there are any interactions between physical and cognitive demands. Recent simulation studies conducted (DiDomenico and Nussbaum, 2008, Basahel et al., 2010, Perry et al., 2008) have subsequently indicated that such interactions are possible.

Armstrong presented a conceptual model that demonstrated the relationship between risk factors and musculoskeletal disorders. The model showed that how external factors and work demands could cause disturbances depending upon the required capacity. The immediate responses that occur after performing the task could be biomechanical, physiological and psychological. The Armstrong model is, however, focused on the relation between risk factors and musculoskeletal disorders and does not discuss the cognitive factors that might influence task performance.

The Wickens multiple resource model, seems to suggest that processing of information flows from sensory input to the processing stage through particular channels depend upon the type of information and type of task – specifically whether the task is mainly verbal or spatial (Wickens, 1984). The performance of an individual depends upon his/ her capacity limit, specifically when interacting with different task at the same time (time-shared) (Wickens, 2002). For instance, studies have examined the impact of workload difficulty on attention resource capacity using primary and secondary tasks. It was found that increasing difficulty in the primary task leads to decreased secondary task performance, since resources have a limited capacity (Wickens, 2008). Therefore, if the amount of resources required to complete a task exceeds the upper limit of available resources in the same modality, performance will suffer.

The three laboratory studies in this PhD research looked at interactions between physical and cognitive demands, both on performance and subjective performance. Study 1 found only one interaction between pacing and work height for perceived performance, which could be expected as the perceived performance was found to be worse at high pacing + above

shoulder height as compared to the perceived performance at high pacing+ elbow height. However, this interaction may not be considered as a relationship between physical and cognitive demands. Study 1 also found an interesting effect of work height on perceived mental demand. This developed the base for relationship between physical and cognitive demands, which was further analysed through study 2 and study 3. Study 2 found an interesting interaction between pacing and assembly variability. The number of completed assemblies was found to be low when working in the high pacing and above shoulder height condition. Study 3 found interesting effects that develop our understanding of the relationship between physical and cognitive demands. It was found that assembly time, number of correct code responses, number of completed assemblies and number of dropped nuts and bolts were all affected by the high memory load and above shoulder height condition. Similarly all raw TLX dimension (perceived mental demand, physical demand, temporal demand, performance and effort), and fatigue were all affected by the task that involved working above shoulder height and high memory load.

One of the research question mentioned in chapter 2 is how different theories for the interaction between physical and cognitive demands could be examined. The results of study 1, 2 and 3 from theoretical perspective, have been discussed in relevant chapters. Overall, the findings of this research, from Armstrong model, specifically considering the finding of study 3 (which was carried out by combing the variables of study 1 and 2 in order to understand in more detail the effects of physical and cognitive demands under high pacing/ Takt conditions), have revealed that increased physical demands (work height at above shoulder height and fastening of nuts and bolts) and cognitive demands (variable assembly order and memory load) as an external exposure led to dose and impeded the performance physically and psychologically. As discussed in chapter 2 that contribution of physical

exertion with mental load in task performance is significant and constitute a gap in the literature (DiDomenico et al., 2008; Bahasal, et al., 2010). Therefore this research has revealed the effect of simultaneous performance of physical demands on the quality of physical and psychological performance.

This research has therefore filled the literature gap by analysing the research question related to Armstrong dose capacity model that how physical and cognitive demands could be perceived through the Armstrong dose capacity model. Moreover, findings of this research have supported the Wickens (2002) multiple resource model by revealing that the performance suffered more under high pacing/ Takt conditions due to assembly variability order (representing mixed model assembly line), which required verbal and visuo-spatial resources as compared to consistent assembly (representing single model assembly line operation). Consistent assembly order did not require verbal resources.

This research has found the effects of physical and cognitive demands and their interaction on the quality of performance and subjective response from the theoretical perspective, which may be helpful for the readers and organisation. However, simultaneous performance of physical and cognitive demands may further be understood considering the theoretical model of Marras and Hancock (2014) propose a conceptual model that illustrates the interpretation of task through the perception of various physical and cognitive components. This model of interaction may be used to understand the effects of physical and cognitive demands on perception and may be tested within the laboratory considering the variables of this research.

Objective 4: To apply ergonomics methods to evaluate task performance in detail

The findings from the analysis of the literature and from the field study were used to develop an approach for conducting the laboratory studies in order to further investigate the effects of physical and cognitive demands under different levels of pacing (as in a Takt time system) on quality of performance and subjective responses, and to determine whether there is an interaction between physical and cognitive demands in their effects.

Overall the present studies showed significant effects of the levels of assembly order, work height and memory load on objective and subjective measures. These studies have shown the main effects of physical demand on cognitive load and the effects of cognitive demand on physical load and also the interaction between physical and cognitive demand.

9.3 Limitations and recommendations for Future work

One of the limitations of this research was that the participants who were students and staff of the university. The participants were not skilled and fully aware of the requirement of assembly line operation. Therefore, field studies need to be carried out on workers involved in simultaneous performance of physical and cognitive demands in assembly line operations using objective and subjective measures; Physical well being checklist, stress and NASA TLX (tool to measure physical and cognitive demands when performed simultaneously) in order to understand the perception of physical and cognitive demands and the impact on quality of performance.

Based on the results of this research, other future work is suggested:

- The present study has investigated the main effects of physical and cognitive demands on quality of performance and subjective

perceptions of workload and stress. Further field investigations to determine the extent to which the same effects and relationships may be seen in the real work environment.

- Further laboratory study of similar design to Study 3 is suggested to consider a wider range of levels of physical and cognitive demands to better understand further the effects and interaction between physical and cognitive demands.
- Alternate methods for measuring physical and cognitive demands which may include physical measures, RULA etc., may be used to validate the results of current study
- The sample size may be increased to analyse the effects of physical and cognitive demands in more detail.
- Study 3 found that the assembly time was higher at no instruction assembly + high memory as compared to the assembly time was lower at no instruction assembly + low memory load. However, interaction at no instruction might have occurred due to all participants first performed all no instructions conditions first. It needs a further study to test whether this effect was because it is having no instruction that means high cognitive load affects assembly time, or whether it is being new to the task that leads to the effect of cognitive load.

References

- AASE, G. R., OLSON, J. R. & SCHNIEDERJANS, M. J., 2004. U-shaped assembly line layouts and their impact on labour productivity: An experimental study. *European Journal of Operational Research*, 156, 698-711
- ÅHSBERG, E., GAMBERALE, F., & KJELLBERG, A., 1997. Perceived quality of fatigue during different occupational tasks. Development of a questionnaire. *International Journal of Industrial Ergonomics*, 20, pp. 121–135
- ANDERSEN, J.H., ET AL., 2003. Risk factors in the onset of neck/ shoulder pain in a prospective study of workers in industrial and service companies. *Occupational and Environmental Medicine*, 60, 649–654.
- ARMSTRONG, T. J., BUCKLE, P., FINE, L. J., HAGBERG, M., JONSSON, B., KILBOM, A. & VIIKARI-JUNTURA, E. R., 1993. A conceptual model for work-related neck and upper-limb musculoskeletal disorders. *Scandinavian journal of work, environment & health*, 73-84.
- ASTIN, A. AND NUSSBAUM M. A., 2002. Interactive effects of physical and mental workload on subjective workload assessment. *Proceeding of the Human Factors and Ergonomics Society 46th Annual Meeting*, 46 (13), pp.1100-1104.
- BATTISTE, V., & BORTOLUSSI, M., 1988. Transport pilot workload: A comparison of two subjective techniques. In *Proceedings of the Human Factors and Ergonomics Society Annual Meeting*, 32, pp. 150-154
- BARNES, R.M., 1963. Motion and time study: *Design and measurement of work*. 5th ed. New York: John Wiley & Sons.
- BOSCH, T., MATHIASSEN, S. E., VISSER, B., DE LOOZE, M. P. & VAN DIEEN, J. H. 2011. The effect of work pace on workload, motor variability and fatigue during simulated light assembly work. *Ergonomics*, 54, 154-168.

- BRENNER, M. D., FAIRRISS, D. & RUSER, J. 2004. "Flexible" Work Practices and Occupational Safety and Health: Exploring the Relationship Between Cumulative Trauma Disorders and Workplace Transformation. *Industrial Relations: A Journal of Economy and Society*, 43, 242-266.
- BOSCH, T., MATHIASSEN, S. E., VISSER, B., DE LOOZE, M. P. & VAN DIEEN, J. H. 2011. The effect of work pace on workload, motor variability and fatigue during simulated light assembly work. *Ergonomics*, 54, 154-168.
- BYERS, J. C., BITTNER, A. C., & HILL, S. G., 1989. Traditional and raw task load index (TLX) correlations: Are paired comparisons necessary. *Advances in industrial ergonomics and safety I*, 481-485.
- COX-FUENZALIDA, L.E., 2007. Effect of workload history on task performance. *Human Factors*, 49, pp.277-291.
- COX, T. 1985. The Nature and Measurement of Stress. *Ergonomics*, 28, 1155-1163.
- DELBRIDGE, R., LOWE, J. & OLIVER, N. 2000. Shop floor responsibilities under lean team working. *Human Relations*, 53, 1459-1479.
- DEMPSEY, P. G., MATHIASSEN, S. E., JACKSON, J. A. & O'BRIEN, N. V. 2010. Influence of three principles of pacing on the temporal organisation of work during cyclic assembly and disassembly tasks. *Ergonomics*, 53, 1347-1358.
- DIDOMENICO, A. AND NUSSBAUM, M. A., 2008. Interactive effects of physical and mental workload on subjective workload assessment. *International Journal of Industrial Ergonomics*, 38, pp. 977-983.
- DIDOMENICO, A. AND NUSSBAUM, M. A., 2011. Effect of different physical workload parameters on mental workload and performance. *International Journal of Industrial Ergonomics*, 41, pp. 255-260.

DOTOV, D. G., & FRANK, T. D., 2011. From the W-method to the canonical-dissipative method for studying uni-manual rhythmic behaviour. *Motor control*,15(4).

DRURY, C. G. 2000. Global quality: linking ergonomics and production. *International journal of production research*, 38, 4007-4018.

DUL, J. & NEUMANN, W.P., 2009. Ergonomics contribution to company strategies. *Applied Ergonomics*, 40, pp.745–752

EKLUND, J., 1996. Conflicts and harassment as risk factor for musculoskeletal shoulder problems. *Contemporary Ergonomics*, 227-232.

ESCORPIZO, R. S. & MOORE, A. E. 2007. Quantifying precision and speed effects on muscle loading and rest in an occupational hand transfer task. *International Journal of Industrial Ergonomics*, 37, 13-20.

FALCK, A. AND ROSENQVIST, M. (2012). What are the obstacles and needs of proactive ergonomics measures at early product development stages? – An interview study in five Swedish companies. Published in *International Journal of Industrial Ergonomics*: 42, 406-415.

FREDERICKS, T. K., CHOI, S.D., HART, J., BUTT, S.E. AND MITAL A., 2005. An investigation of myocardial aerobic capacity as a measure of both physical and cognitive workloads, *International Journal of Industrial Ergonomics*, 35, pp.1097-1107.

GARG, A., HEGMANN, K. & KAPELLUSCH, J. 2006. Short-cycle overhead work and shoulder girdle muscle fatigue. *International Journal of Industrial Ergonomics*, 36, 581-597.

GENAIDY, A. M. & KARWOWSKI, W. 2003. Human performance in lean production environment: Critical assessment and research framework. *Human Factors and Ergonomics in Manufacturing & Service Industries*, 13, 317-330.

Grandjean, E., & Kroemer, K. H. E., 199). Fitting the task to the human: A textbook of occupational ergonomics (5th ed.). *Taylor & Francis*.

HAGBERG M, SILVERSTEIN B, WELLS R, SMITH M, HENDRICK H, CARARYON P, PERUSSE M (1995): Chapter 4 Identification, measurement and evaluation of risk pp 139–212. In Kuorinka, Forcier (eds): *Work-Related Musculoskeletal Disorders—A Manual for Prevention*. Taylor & Francis, London.

HART, S. & STAVELAND, L. 1988. Development of NASA-TLX (Task Load Index): Results of empirical and theoretical research. *Human Mental Workload*, 139-183.

HASLEGRAVE, C.M., 1990. How well can ergonomists address problems identified in workplace. In: Haslegrav, C.M., Wilson, J.R., Nogel Corlett, E. and Manenica, I., (eds) *Work design in practice: Proceeding of the Third International Occupational Ergonomics Symposium, London: Taylor and Francis*, pp 22-29

HERBERTS, P. and KADEFORS, R., 1976. A study of painful shoulder in welders. *Acta Orthopaedica Scandinavica*, 47, 381–387.

HHU, X., HU, S.J., KOREN, Y., MARIN, S.P. 2008, Modeling of Manufacturing Complexity in Mixed-Model Assembly Lines, *Journal of Manufacturing Science and Engineering*, Vol. 130

HU, S.J., KO, L., WEYAND, L., EIMARAGH, H.A., LIEN, T.K., KOREN, Y., BLEY, H., CHYSSOLOURIS, G. NAS, N., & SHIPTALNI, M., 2001. Assembly system design and operations for product variety. *CIRP Annals - Manufacturing Technology*.

HWANG, S.L., YAU, Y.J., LIN, Y.T., CHEN, J.H., HUANG, T.H., YENN, T.C. AND HSU, C.C., 2008. Predicting work performance in nuclear power plants, *Safety Science*, 46, pp.1115-1124.

IKUMA, L. H., NUSSBAUM, M. A. & BABSKI-REEVES, K. L. 2009. Reliability of physiological and subjective responses to physical and psychosocial exposures

during a simulated manufacturing task. *International Journal of Industrial Ergonomics*, 39, 813-820

KAHNEMAN, D., 1973. *Attention and Effort* (Englewood Cliffs, NJ:Prentice-Hall)

K. LANDAU, R. WIMMER, H. LUCZAK, J. MAINZER, H. PETERS, G. WINTER, Arbeit im Montagebetrieb [Work in assembly factory], in: K. Landau, H. Luczak (Eds.), *Ergonomie und Organisation in der Montage*, Hanser, München, Germany, 2001, pp. 1–82.

LEWCHUK, W. & ROBERTSON, D. 1997. Production without empowerment: Work reorganization from the perspective of motor vehicle workers. *Capital & Class*, 21, 37.

LEWCHUK, W., STEWART, P. & YATES, C. 2001. Quality of working life in the automobile industry: A Canada-UK comparative study. *New Technology, Work and Employment*, 16, 72-

LOUHEVAARA, V. AND KILBOM, A., 2005. Dynamic work assessment. In Wilson, J.R. and Corlett, N. (Eds.). *Evaluation of human work*, (Taylor and Francis Group, US), pp.429-451.

LAURSEN, B., JENSEN, B.R., GARDE, A.H., AND JØRGENSEN, A.H., 2002. Effect of mental and physical demands on muscular activity during the use of a computer mouse and a keyboard, *Scand J Work Environ Health*, 28 (4), pp.215-221.

LANDSBERGIS, P. A., CAHILL, J. & SCHNALL, P. 1999. The impact of lean production and related new systems of work organization on worker health. *Journal of Occupational Health Psychology*, 4, 108.

LIN, L., DRURY, C. G. & KIM, S. W. 2001. Ergonomics and quality in paced assembly lines. *Human Factors and Ergonomics in Manufacturing*, 11, 377-382.

MACDONALD, W. & S. BENDAK. 2000. Effects of workload level and 8- versus 12-h workday duration on test battery performance. *International Journal of Industrial Ergonomics* 26(3): 399-416.

MCATAMNEY, L., 1994. The inter-relationship of risk factors associated with upper limb disorders in VDU users. *Ph.D Thesis*. University of Nottingham, Nottingham.

[MARRAS, W.S.](#), & [HANCOCK, P.A.](#), 2014. Putting mind and body back together: a human-systems approach to the integration of the physical and cognitive dimensions of task design and operations. [Applied Ergonomics](#), 45, pp. 55-60.

MARRAS, W.S., & SHOENMARKLIN, R.W., 1993. Wrist motions in Industry. *Ergonomics*, 36, pp. 341-351.

MATHIASSEN, S. E. (2006). "Diversity and variation in biomechanical exposure: What is it, and why would we like to know?" [Applied Ergonomics](#) **37**(4): 419-427

MEGAW, T., 2005. The definition and measurement of mental workload. In J. R. Wilson and N. Corlett (Eds.), *Evaluation of Human Work*, (Taylor & Francis Group: US), pp.525-551

MOZRALL, J. R. AND C. G. DRURY., 1996. Effects of physical exertion on task performance in modern manufacturing: taxonomy, a review, and a model. *Ergonomics*, 39(10), pp.1179-1213.

MILLER, G. A. 1956, The magical number seven, plus or minus two: Some limits on our capacity for processing information, *The Psychological Review*, 63, 81 – 97.

- MIRANDA, H., VIIKARI-JUNTURA, E., HEISTARO, S., HELIOVAARA, M., RIIHIMAKI, H., 2005. A population study on differences in the determinants of a specific shoulder disorder versus nonspecific shoulder pain without clinical findings. *American Journal of Epidemiology*, 161, 647–655
- MIRKA, G. AND BAKER, A., 1994. An Investigation of the variability in human performance during manual material handling activities. *Proceedings of the Human Factors and Ergonomics Society Annual Meeting*, 38(10), pp.578-582
- MORONEY, W. F., BIERS, D. W., EGGEMEIER, F. T. & MITCHELL, J. A. 1992. A Comparison of 2 Scoring Procedures with the Nasa Task Load Index in a Simulated Flight Task. *Proceedings of the Ieee 1992 National Aerospace and Electronics Conference - Naecon 1992 : Vols 1-3*, 734-740.
- NEERINCX, M.A. AND GRIFFIOEN, E., 1996. Cognitive task analysis: harmonizing tasks to human capacities. *Ergonomics*, 39, pp.543-561
- NEUMANNR, W., KIHLEBERG, S., MEDBO, P., MATHIASSEN, S. E. & WINKEL, J. 2002. A case study evaluating the ergonomic and productivity impacts of partial automation strategies in the electronics industry. *International journal of production research*, 40, 4059-4075.
- PERRY, C.M., SHEIK-NAINAR, M.A., SEGALL, N., MA R. AND KABER, D.B., 2008. Effects of physical workload on cognitive task performance and situation awareness, *Theoretical Issues in Ergonomics Science*, 9, pp.95-113.
- REMPEL, D. M., HARRISON, R. J., & BARNHART, S., 1992. Work-related cumulative trauma disorders of the upper extremity. *Jama*, 267(6), 838-842.
- RICHARDSON, M. JONES, G. & TORRANCE M. (2004): Identifying the task variables that influence perceived object assembly complexity, *Ergonomics*, 47:9, 945-964

RICHARDSON, M., JONES, G., TORRANCE M. & BAGULEY, T., 2006. Identifying the Task Variables That Predict Object Assembly Difficulty. *The Journal of the Human Factors and Ergonomics Society*, 48: 511

[SHAIKH, S.](#), [COBB, S.V.](#), [GOLIGHTLY, D.](#), [SEGAL, J.I.](#), & [HASLEGRAVE, C.M.](#), 2012. Investigating the effects of physical and cognitive demands on the quality of performance under different pacing levels. *Journal of Work*, 41, pp.1625-31.

SHAH, R. & WARD, P. T. 2003. Lean manufacturing: context, practice bundles, and performance. *Journal of Operations Management*, 21, 129-149.

SHEPHERD, A., 1986. Issues in training of process operators. *International journal Industrial Ergonomics*, 1, pp. 49-64.

SLUITER, J.K., 2006. High-demand jobs: Age-related diversity in work ability? *Applied Ergonomics*, 4, pp.429-440.

SMITH, T.J., 2000. The ergonomics of learning: educational design and learning performance, *Ergonomics*, 50:10, 1530-1546

SMYTH, G AND HASLAM, RA (1995) Identifying Risk Factors for the Development of Work-Related Upper Limb Disorders. In Robertson, SAE (ed) *Ergonomics Society*, Contemporary Ergonomics, Canterbury, pp.440-445.

SOOD, D., NUSSBAUM, M. A., & HAGER, K. 2007. Fatigue during prolonged intermittent overhead work: reliability of measures and effects of working height. *Ergonomics*, 50, pp. 497-513.

STORK, S. AND SCHUBÖ, A., 2010. Human cognition in manual assembly: Theories and applications. *Advance Engineering Information*, 24(3), pp.320-328.

SVENDSEN, S. W., BONDE, J. P., MATHIASSEN, S. E., STENGAARD-PEDERSEN, K., & FRICH, L. H. 2004. Work related shoulder disorders: quantitative exposure-response relations with reference to arm posture. *Occupational and environmental medicine*, 61(10), 844-853.

TAN, J. T. C., DUAN, F., ZHANG, Y., & ARAI, T. (2008, September). Task decomposition of cell production assembly operation for man-machine collaboration by HTA. In *Automation and Logistics, 2008. ICAL 2008. IEEE International Conference on* (pp. 1066-1071). IEEE.

TOMPOROWSKI, P.D. AND ELLIS, N. R., 1986. Effects of exercise on cognitive processes: A review. *Psychological Bulletin*. 99(3), pp. 338-346.

TOMPOROWSKI, P.D., 2003. Effects of bouts of exercise on cognition. *Acta Psychologica*, 112, pp.297-324.

TRINKOFF, A.M., [LE, R.](#), [GEIGER-BROWN, J.](#), [LIPSCOMB, J.](#), & [LANG, G.](#), 2006. Longitudinal relationship of work hours, mandatory overtime, and on-call to musculoskeletal problems in nurses. *American Journal of Industrial Medicine*, 49 (11), 964–971.

WELLS, R.A.B., MATHIASSEN, S., MEDBOD, L., & WINKEL, J., 2007. Time—A key issue for musculoskeletal health and manufacturing. *Applied Ergonomics* 38, pp.733–744.

WICKENS, C. D., 2002. Multiple resources and performance prediction. *Theoretical Issues in Ergonomics Science*, 3, pp.159-177.

WICKENS, C. D., 2008. Multiple resources and mental workload. *Human Factors*, 50, pp.449-455.

WICKENS, C. D. AND HOLLAND, J. G., 2000. Attention, time sharing and workload. In C. D. Wickens, J. G. Holland (Eds.). *Engineering psychology and*

human performance (3rd ed.), (Upper Saddle River, NJ: Prentice Hall), pp.439-479.

WOMACK, J. P., JONES, D. T. & ROOS, D. 1990. *The machine that changed the world: based on the Massachusetts Institute of Technology 5-million dollar 5-year study on the future of the automobile*, Scribner.

WOMACK, J. P. & JONES, D. T. 2003. *Lean thinking: banish waste and create wealth in your corporation*, Simon and Schuster.

WALKER, C. R. & GUEST, H. 1952. *'The man on the assembly line'*, Harward University Press.

XIE B. AND SALVENDY G., 2000. Review and reappraisal of modelling and predicting mental workload in single and multi-task environments. *Work & Stress*, 14, pp.74-99

ZHU, X., HU, S. J., KOREN, Y., & MARIN, S. P. (2008). Modelling of manufacturing complexity in mixed-model assembly lines. *Journal of Manufacturing Science and Engineering*, 130(5), 051013.

Appendix 1 Subject Information Sheet for Study 1

Study to determine the interaction between physical and cognitive demands of dual task of memory load and assembly operations under different pacing conditions

You are being invited to take part in an experiment to determine the interaction between physical and cognitive demands of the operators under three different pacing conditions.

The aim of the experiment is to obtain a better understanding of the impacts of physical and cognitive demands on performance in different working conditions in a simultaneous memory and light assembly task.

The experiment consists of 12 conditions to be performed by each participant. You will be asked to do the task for approximately 2 hours on each of three days (approximately six hours total). Your three sessions will be arranged at times to suit you over the period of a week.

The study will take place in the usability laboratory, where you will be asked to perform a simple cognitive task and a physical assembly task simultaneously. The cognitive task includes the memorising of numbers, which will appear on the computer screen and then disappear shortly before you start the physical assembly task. The physical assembly task involves the fastening of nuts and bolts on a component. The experimenter will explain the equipment being used and you will have a practice session to give you the opportunity to familiarise yourself with the sequence of the task.

Each task will last for 10 minutes, and then you have a break of five minutes before the next task. During the break you will fill in some questionnaires.

Information will be collected in the form of computer data and questionnaire responses and will be retained and securely stored by the University of Nottingham in accordance with data protection policies. It will be used solely

for the purpose of this research, including academic publication. Data will only be accessible by people directly involved in this research. No personal information (e.g. name, contact details) will be associated with your responses; it will not be possible to identify you from response data. You will be allocated an ID number upon arrival and this will be used on your responses.

Video recording and photographs may be taken during the experiment but these will only be used in the report with your permission.

If you have any questions please do not hesitate to ask.

Your participation in this study is very much appreciated

Appendix 2 Subject Information Sheet for Study 2

Study to investigate the effects of physical and cognitive aspects of tasks (Assembly order and memory load) on the quality on performance and subjective responses

You are being invited to take part in an experiment to determine the interaction between physical and cognitive demands of the operators under three different pacing conditions.

The aim of the experiment is to obtain a better understanding of the impacts of physical and cognitive demands on performance in different working conditions in a simultaneous memory and light assembly task.

The experiment consists of 08 conditions to be performed by each participant. You will be asked to do the task for approximately 2 hours 20 minutes.

The study will take place in the usability laboratory, where you will be asked to perform a simple cognitive task and a physical assembly task simultaneously. The cognitive task includes the memorising of numbers, which will appear on the computer screen and then disappear shortly before you start the physical assembly task. The physical assembly task involves the fastening of nuts and bolts on a component. The experimenter will explain the equipment being used and you will have a practice session to give you the opportunity to familiarise yourself with the sequence of the task.

Each task will last for 10 minutes, and then you have a break of five minutes before the next task. During the break you will fill in some questionnaires.

Information will be collected in the form of computer data and questionnaire responses and will be retained and securely stored by the University of Nottingham in accordance with data protection policies. It will be used solely for the purpose of this research, including academic publication. Data will only be accessible by people directly involved in this research. No personal

information (e.g. name, contact details) will be associated with your responses; it will not be possible to identify you from response data. You will be allocated an ID number upon arrival and this will be used on your responses.

Video recording and photographs may be taken during the experiment but these will only be used in the report with your permission.

If you have any questions please do not hesitate to ask.

Your participation in this study is very much appreciated.

Appendix 3 Subject Information Sheet for Study 3

You are being invited to take part in an experiment to investigate effects of cognitive aspects of the task (consistent or variable order of assembly and low and high memory load) interact with those of physical load.

The aim of the experiment is to obtain a better understanding of the impacts of physical and cognitive demands on performance in different working conditions in a simultaneous memory and light assembly task.

The experiment consists of 12 conditions to be performed by each participant. Each condition will last for 10 minutes, and then you have a break of five minutes before the next task. During the break you will fill in some questionnaires. The total time for the whole study will be 3 hours 30 mins appx.

The study will take place in the usability laboratory, where you will be asked to perform a simple cognitive task and a physical assembly task simultaneously. The cognitive task includes the memorising of numbers, which will appear on the computer screen and then disappear shortly before you start the physical assembly task. The physical assembly task involves the fastening of nuts and bolts on a component. The experimenter will explain the equipment being used and you will have a practice session to give you the opportunity to familiarise yourself with the sequence of the task.

Information will be collected in the form of computer data and questionnaire responses and will be retained and securely stored by the University of Nottingham in accordance with data protection policies. It will be used solely for the purpose of this research, including academic publication. Data will only be accessible by people directly involved in this research. No personal information (e.g. name, contact details) will be associated with your responses; it will not be possible to identify you from response data. You will

be allocated an ID number upon arrival and this will be used on your responses.

Video recording and photographs may be taken during the experiment but these will only be used in the report with your permission.

If you have any questions please do not hesitate to ask.

Your participation in this study is very much appreciated.

Appendix 4 General Well-Being Questionnaire

This questionnaire asks about your general well-being. The information you give will be used for statistical purposes only and is completely anonymous and confidential.

INSTRUCTIONS

Please read the following questions carefully and decide how often the symptoms have bothered or distressed you over the last six months.

	All the time	Often	Some	Rarely	Never
1. Have you been perfectly well and in good health?	4	3	2	1	0
2. Have you been forgetful?	4	3	2	1	0
3. Have you become annoyed and irritated easily?	4	3	2	1	0
4. Have you got bored easily?	4	3	2	1	0
5. Has it been hard for you to Make up your mind?	4	3	2	1	0
6. Have you got tired easily?	4	3	2	1	0
7. Have you had numbness or tingling in your arms or legs?	4	3	2	1	0
8. Have you done things on impulses?	4	3	2	1	0
9. Have you been getting any pains in your head?	4	3	2	1	0
10. Have you been taking longer Over the things you do?	4	3	2	1	0
11. Have you been tense and jittery?	4	3	2	1	0
12. Have you been managing to keep yourself busy and occupied?	4	3	2	1	0
13. Have you had difficulty in staying asleep once you are off?	4	3	2	1	0
14. Have you been getting scared or panicky without no good reason?	4	3	2	1	0
15. Have you felt capable of	4	3	2	1	0

Appendix 6 Physical Well-Being Checklist

Questionnaire

This checklist asks you about how you feel at the moment. Please answer each question carefully.

1. Do you feel at the moment energetic lively, extremely tired or fatigued?

- a. No ___
- b. Yes

If YES, carefully mark a scale with a cross.

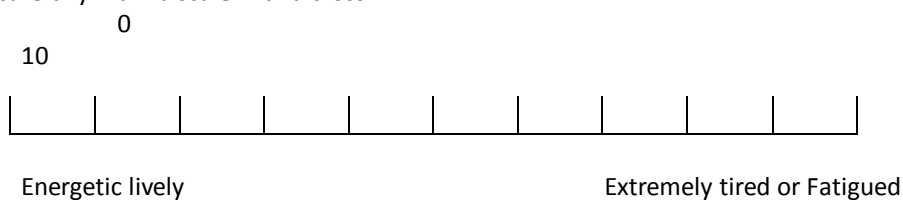

2. Do you have at the moment head ache, migraine or eye strain?

- a. No ___
- b. Yes

If YES, carefully mark a scale with a cross.

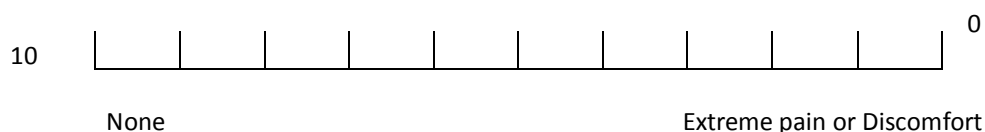

3. Do you have at the moment any discomfort, ache or pain (not including headaches or eye strain) in any part of your body?

- 1. No ___
- 2. Yes

If YES, carefully shade the area(s) in which you feel this discomfort, ache or pain on the diagram. Then name each area, rate the severity experienced on the scales below.

Area (Starting with the worst area)	Severity rating at the moment
	None Severe
1.	
2.	
3.	
4.	

INSTRUCTIONS

Shade each area of pain, ache or discomfort as accurately as you can on the diagrams below. If you have shaded one area only call it 'Area 1' when answering the following questions.

If you have more than one area of pain, ache or discomfort shade each area as accurately as you can. Then number the areas in order of how severe or disrupting they have been,

e.g. 1= worst area, 2= next to worst area, and so on.

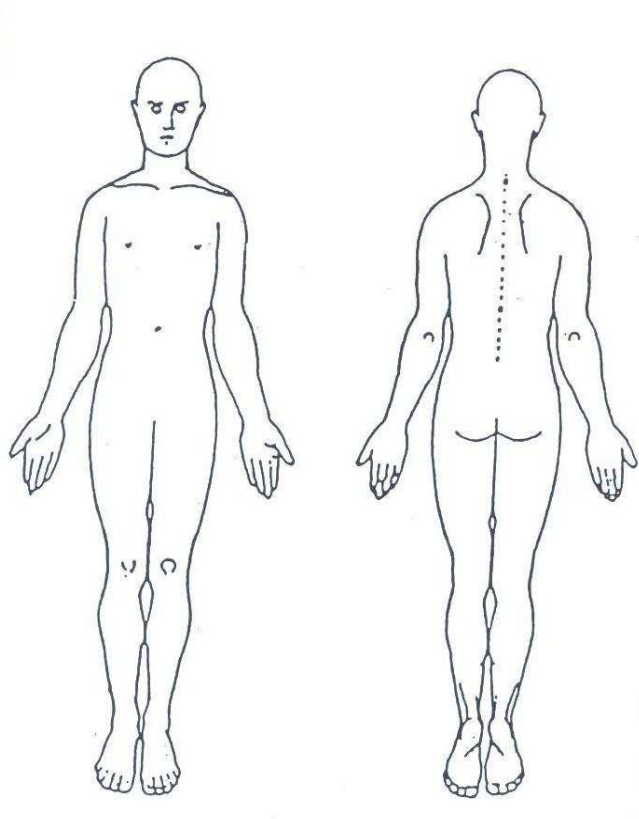

Appendix 7 Stress and Arousal Checklist

The adjectives below describe different feelings and moods. Please use this list to describe your feelings at this moment in time.

If the adjective definitely describe your feelings circle the:

++ + ? -

If the adjective more or less describe your feeling circle the:

++ + ? -

If you do not understand the adjective, or you can not decide whether it describes how you feel circle the:

++ + ? -

If the adjective does not describe the way you feel circle the:

++ + ? -

Your first reactions will be the most reliable; therefore do not spend too long thinking about each adjective. Please be as honest and accurate as possible.

Tense	++ + ? -	Tired	++ + ? -
Relaxed	++ + ? -	Idle	++ + ? -
Restful	++ + ? -	Up tight	++ + ? -
Active	++ + ? -	Alert	++ + ? -
Apprehensive	++ + ? -	Lively	++ + ? -
Worried	++ + ? -	Cheerful	++ + ? -
Energetic	++ + ? -	Contented	++ + ? -
Drowsy	++ + ? -	Jittery	++ + ? -
Bothered	++ + ? -	Sluggish	++ + ? -
Uneasy	++ + ? -	Pleasant	++ + ? -
Nervous	++ + ? -	Sleepy	++ + ? -

Distressed ++ + ? -

Comfortable ++ + ? -

Peaceful ++ + ? -

Calm ++ + ? -

Appendix 8 Observational Check list

Assembly Task	Completed (out of six nuts and bolts)	Number dropped	Quality of fastening the nuts and bolts	Other comments
1				
2				
3				
4				
5				
6				

Experience

How much technical experience is required? What type of experience?

Assertiveness

To what extent does the task depend upon the assertiveness of the technician?

Task Management

Multi-tasking

How often does this task have to be completed at the same time as doing something else?

Time organisation and planning

Distraction

To what extent is this task subject to distraction? From where does the distraction come?

Interruption

To what extent is this task subject to interruption? From where does the interruption come?

Routine?

Is the task routine or non-routine?

Scheduled?

Task focus

Does the technician complete the whole task or part of the task

2. THE SOCIAL

The Team

Team co-ordination

To what extent does this task depend upon team co-ordination?

Team-Task relationship

How many individuals are involved? To what extent is previous experience to work in team is necessary?

Allocation of functions to team members

Is each team member allocated a specific/precise sub-task?

To what extent are team members free to organise their collective activity?

Shift hand-over

Do shift hand-overs occur during the task? How often and how are they managed?

Leadership

Is there a clear leadership structure? How often does this affect the task?

Communication

Communication during task

How much communication is necessary during the task execution? What type(s) of communication?

Location/dispersal of team

Are team members physically distributed when working on the task? Are they located in the same area? Where are they located?

Team pressure

To what extent is this task subject to team pressure? What is the nature of this pressure?

Team dynamics

What are the dynamics of the team? How do they work together? How does this affect the task?

3. THE WORKPLACE

Task Support

Tools

How do tools affect the task?

Parts

How do parts affect the task?

Manuals/documentation

In what way do manuals and documentation affect the task?

Job cards

How do job cards affect the task?

Signing for/records

In what way does signing for affect the task?

Degree of interaction with IT systems

Performance Shaping Factors

Fatigue

To what extent does this influence the task?

Noise

To what extent does this influence the task?

Lighting

To what extent does this influence the task?

Access – physical & visual

To what extent does this influence the task?

Dexterity

To what extent does this influence the task?

Weather

To what extent does this influence the task?

Surface

To what extent do the surface conditions influence the task?

Fumes

To what extent does this influence the task?

Stress

To what extent does stress manifest itself during the task?

Comfort

To what extent is comfort an issue in this task?

The Operation and Organisation

Time pressure

To what extent is the task subject to time pressure?

Commercial pressure

To what extent is the task subject to this?

Safety critical

To what extent is the task safety critical?

Efficiency critical

To what extent is the task efficiency critical?

Shift-work

To what extent does this influence the task?

Legal framework

How is the task affected by legal/regulatory issues (certification levels, signing off etc.).

Additional Information