



The University of  
**Nottingham**

UNITED KINGDOM • CHINA • MALAYSIA

Naghiyev, Eldar (2014) Device-free localisation in the context of domestic energy saving control methods. PhD thesis, University of Nottingham.

**Access from the University of Nottingham repository:**

[http://eprints.nottingham.ac.uk/14314/1/PhD\\_Thesis\\_-\\_Eldar\\_Naghiyev.pdf](http://eprints.nottingham.ac.uk/14314/1/PhD_Thesis_-_Eldar_Naghiyev.pdf)

**Copyright and reuse:**

The Nottingham ePrints service makes this work by researchers of the University of Nottingham available open access under the following conditions.

This article is made available under the University of Nottingham End User licence and may be reused according to the conditions of the licence. For more details see:  
[http://eprints.nottingham.ac.uk/end\\_user\\_agreement.pdf](http://eprints.nottingham.ac.uk/end_user_agreement.pdf)

**A note on versions:**

The version presented here may differ from the published version or from the version of record. If you wish to cite this item you are advised to consult the publisher's version. Please see the repository url above for details on accessing the published version and note that access may require a subscription.

For more information, please contact [eprints@nottingham.ac.uk](mailto:eprints@nottingham.ac.uk)

**DEVICE-FREE LOCALISATION  
IN THE CONTEXT OF  
DOMESTIC ENERGY SAVING  
CONTROL METHODS**

ELDAR NAGHIYEV, MSc

Thesis submitted to the University of Nottingham for the  
degree of Doctor of Philosophy

JULY 2014

## **ABSTRACT**

A reduction in greenhouse gas emissions by the energy sector is required to decelerate global warming. With the domestic sector being the biggest energy consumer, a great amount of saving potential is available in the operation of dwellings.

This thesis is proposing to improve domestic energy efficiency by combining energy saving control measures designed to be made by occupants and automation systems, called Combined Occupant and Automation Control (COAC). It highlights that the occupant's position is necessary to effectively integrate both of those conservation methods.

Three unobtrusive domestic occupant detection technologies were identified and compared for this purpose. Device-free Localisation (DfL), an emerging technology, which was found to be the most suited for a COAC system, was then investigated further by the means of a series of technical experiments. A questionnaire, investigating user perception of DfL and of COAC systems, was conducted. Furthermore, case studies were undertaken, during which three dwellings with real occupants received prototypes of a COAC system, consisting of automated washing appliances and a smart pricing scheme. As part of these case studies, semi-structured interviews were conducted.

User preferences with regards to the COAC system's interface and operation were established. Also, behavioural changes, induced by occupant control methods, were observed. The different studies furthermore found that financial gain was the main incentive to save energy. Automation system's support in conserving energy was demonstrated to be distinctly appreciated and although security and privacy concerns were prevalent, DfL's support was also permitted. Furthermore, guidance was developed for DfL setup and operation, especially with regards to using an automation system's infrastructure for this purpose.

In conclusion, this research suggests that the novel concept of integrating DfL and COAC meets the technical and practical requirements for general adoption, and hence provides another tool in the race against global warming.

## **ACKNOWLEDGEMENTS**

First and foremost I would like to thank Dr Robin Wilson and Professor Mark Gillott for their combined supervision, which helped me to develop not only on an academic, but also on a professional level.

Special thanks also go to Dr Robert Foster for kindly lending me his experimental equipment.

I am particularly grateful to my parents without whose role model and invaluable support this thesis would not have been possible.

Ultimately, I would like to thank wholeheartedly my girlfriend, fiancée and now wife, Arzoo.



## **PUBLICATIONS**

E. Naghiyev, M. Gillott and R. Wilson, "Three unobtrusive domestic occupancy measurement technologies under qualitative review", *Energy and Buildings*, vol. 69, pp. 507-514, 2014.

R. Shipman, M. Gillott and E. Naghiyev, "SWITCH: Case studies in the demand side management of washing appliances", *Energy Procedia*, vol. 42, pp. 153-162, 2013.

E. Nagijew, M. Gillott and R. Wilson, "A qualitative comparison of unobtrusive domestic occupancy measurement technologies", in *Sustainability in Energy and Buildings: Proceedings of the 4th International Conference in Sustainability in Energy and Buildings (SEB'12)*, A. Hakansson, M. Höjer, R. J. Howlett, L. C. Jain, Eds. Berlin: Springer, pp. 391-400, 2013.

M. Gillott, E. Nagijew, R. Wilson and C. Spataru, "Renewable energy demand reduction strategies for the Solar Decathlon Europe Nottingham H.O.U.S.E" in Proceedings of SET2010 - 9th International Conference on Sustainable Energy Technologies, Shanghai, China, 24-27 August 2010.

**LIST OF CONTENTS**

---

<b>ABSTRACT</b>	i
<b>ACKNOWLEDGEMENTS</b>	ii
<b>PUBLICATIONS</b>	iii
<b>LIST OF CONTENTS</b>	iv
<b>LIST OF FIGURES</b>	x
<b>LIST OF TABLES</b>	xvii
<b>GLOSSARY</b>	xix
<hr/>	
<b>1 INTRODUCTION</b>	1
1.1 TOPIC BACKGROUND	1
1.2 AIM, OBJECTIVES AND METHODS	3
1.3 CONTRIBUTIONS	4
1.4 THESIS SYNOPSIS	5
<hr/>	
<b>2 ENERGY AND BUILDINGS</b>	7
2.1 INTRODUCTION	7
2.2 ENERGY CONSUMPTION AND TRENDS	7
2.2.1 GLOBAL	7
2.2.2 UNITED KINGDOM	10
2.3 DOMESTIC ENERGY LEGISLATIONS	13
2.4 DOMESTIC ENERGY DEMAND REDUCTIONS	14
2.4.1 ENERGY PROVIDERS	14
2.4.2 HOUSEHOLDS	19
2.5 CHAPTER CONCLUSION	24
<hr/>	
<b>3 OCCUPANT AND AUTOMATION CONTROL</b>	25
3.1 INTRODUCTION	25
3.2 OCCUPANT CONTROL	25
3.2.1 FEEDBACK	25
3.2.2 INCENTIVE	28
3.2.3 CONCLUSION	30
3.3 AUTOMATION CONTROL	30

---

3.3.1	APPLICATION METHODS	31
3.3.2	COMMUNICATION	32
3.3.3	HUMAN INTERFACE	33
3.3.4	CONCLUSION	34
3.4	COMBINED OCCUPANT AND AUTOMATION CONTROL	34
3.4.1	CONCEPT	35
3.4.2	REQUIREMENT	35
3.5	CHAPTER CONCLUSION	37
<b>4</b>	<b>OCCUPANT DETECTION TECHNOLOGIES</b>	<b>38</b>
4.1	INTRODUCTION	38
4.2	METHODOLOGY	39
4.3	RESULTS	40
4.3.1	CO <sub>2</sub>	41
4.3.2	PIR	46
4.3.3	DFL	51
4.4	DISCUSSION	54
4.4.1	CO <sub>2</sub>	54
4.4.2	PIR	54
4.4.3	LQI	55
4.5	CONCLUSION	55
4.6	CHAPTER CONCLUSION	56
<b>5</b>	<b>DEVICE-FREE LOCALISATION (DFL)</b>	<b>57</b>
5.1	INTRODUCTION	57
5.2	PHYSICAL PRINCIPLES	57
5.3	LITERATURE REVIEW	59
5.4	HEALTH AND SECURITY	63
5.5	CHAPTER CONCLUSION	64
<b>6</b>	<b>DFL – FEASIBILITY STUDY</b>	<b>65</b>
6.1	INTRODUCTION	65
6.2	EQUIPMENT	65
6.3	FREQUENCY RANGE	66

6.3.1	METHODOLOGY	66
6.3.2	RESULTS	66
6.3.3	DISCUSSION	67
6.3.4	CONCLUSION	68
6.4	HUMAN MOVEMENT AND RADIO SETTINGS	68
6.4.1	METHODOLOGY	68
6.4.2	RESULTS	69
6.4.2.1	FREQUENCY SETTING	69
6.4.2.2	POWER SETTING	72
6.4.2.3	BANDWIDTH SETTING	76
6.4.3	DISCUSSION	79
6.4.4	CONCLUSION	80
6.5	HUMAN PROXIMITY	81
6.5.1	METHODOLOGY	81
6.5.2	RESULTS	83
6.5.3	DISCUSSION	83
6.5.4	CONCLUSION	85
6.6	CHAPTER CONCLUSION	85
<b>7</b>	<b>DFL – COMPREHENSIVE STUDY – PART A</b>	<b>87</b>
7.1	INTRODUCTION	87
7.2	EQUIPMENT	88
7.3	ANTENNA ASSESSMENT	89
7.3.1	2D EXPERIMENT	89
7.3.1.1	METHODOLOGY	90
7.3.1.2	RESULTS	90
7.3.1.3	DISCUSSION	93
7.3.2	3D EXPERIMENT	93
7.3.2.1	METHODOLOGY	93
7.3.2.2	RESULTS	94
7.3.2.3	DISCUSSION	98
7.3.3	CONCLUSION	99
7.4	INDOOR SIGNAL PROPAGATION	100
7.4.1	METHODOLOGY	100

7.4.2	RESULTS	100
7.4.3	DISCUSSION	104
7.4.4	CONCLUSION	105
7.5	ROOM OCCUPANCY	105
7.5.1	ABSOLUTE SIGNAL POWER	106
7.5.1.1	METHODOLOGY	106
7.5.1.2	RESULTS	106
7.5.1.3	DISCUSSION	110
7.5.2	SPATIAL RELATION	110
7.5.2.1	METHODOLOGY	111
7.5.2.2	RESULTS	111
7.5.2.3	DISCUSSION	117
7.5.3	CONCLUSION	118
7.6	CHAPTER CONCLUSION	119
<b>8</b>	<b>DFL – COMPREHENSIVE STUDY – PART B</b>	<b>120</b>
8.1	INTRODUCTION	120
8.2	DENSITY	120
8.2.1	METHODOLOGY	120
8.2.2	RESULTS	123
8.2.3	DISCUSSION	127
8.2.4	CONCLUSION	128
8.3	QUANTITY	128
8.3.1	METHODOLOGY	128
8.3.2	RESULTS	129
8.3.3	DISCUSSION	132
8.3.4	CONCLUSION	133
8.4	LOCALISATION	133
8.4.1	METHODOLOGY	133
8.4.2	RESULTS	134
8.4.3	DISCUSSION	136
8.4.4	CONCLUSION	136
8.5	MULTIPLE PEOPLE LOCALISATION	137
8.5.1	METHODOLOGY	137

	8.5.2 RESULTS	137
	8.5.3 DISCUSSION	139
	8.5.4 CONCLUSION	139
8.6	TRACKING	139
	8.6.1 METHODOLOGY	140
	8.6.2 RESULTS	140
	8.6.3 DISCUSSION	145
	8.6.4 CONCLUSION	146
8.7	CHAPTER CONCLUSION	146
<b>9</b>	<b>DFL – COMPREHENSIVE STUDY – PART C</b>	147
9.1	INTRODUCTION	147
9.2	TEMPORAL RESOLUTION AND HOUSE OCCUPANCY	147
	9.2.1 METHODOLOGY	147
	9.2.2 RESULTS	149
	9.2.3 DISCUSSION	169
	9.2.4 CONCLUSION	170
9.3	CHAPTER CONCLUSION	171
<b>10</b>	<b>USER PERCEPTION</b>	172
10.1	INTRODUCTION	172
10.2	METHODOLOGY	172
10.3	RESULTS	176
10.4	DISCUSSION	189
10.5	CHAPTER CONCLUSION	195
<b>11</b>	<b>COMBINED OCCUPANT AND AUTOMATION CONTROL APPLICATION</b>	196
11.1	INTRODUCTION	196
11.2	METHODOLOGY	196
	11.2.1 HOUSEHOLDS AND OCCUPANTS	197
	11.2.2 TIME DEPENDENT PRICING SCHEME	197
	11.2.3 APPLIANCE AUTOMATION	199
	11.2.4 USER INTERFACE	200
	11.2.5 DATA COLLECTION	201

11.3	RESULTS	201
11.3.1	HOUSEHOLDS AND OCCUPANTS	202
11.3.1.1	BASF HOUSE	202
11.3.1.2	TARMAC 10 HOUSE	204
11.3.1.3	TARMAC 12 HOUSE	204
11.3.2	APPLIANCE AND TARIFF USAGE	205
11.3.3	POST-CASE STUDY FEEDBACK	212
11.3.3.1	BASF – WEBSITE ONLY	212
11.3.3.2	BASF – TABLET	213
11.3.3.3	TARMAC 10 – TABLET	215
11.3.3.4	TARMAC 10 – OVERRIDE SWITCH	216
11.3.3.5	TARMAC 12 – WEBSITE ONLY	217
11.3.3.6	TARMAC 12 – OVERRIDE SWITCH	218
11.4	DISCUSSION	219
11.5	CHAPTER CONCLUSION	221
<b>12</b>	<b>CONCLUSION</b>	223
12.1	INTRODUCTION	223
12.2	DISCUSSION AND CONCLUSIONS	223
12.3	FUTURE RESEARCH DIRECTIONS	226
	<b>REFERENCES</b>	227
<b>APPENDIX A</b>	<b>HOUSEHOLD ELECTRICITY USE SURVEY DATA</b>	243
<b>APPENDIX B</b>	<b>USER PERCEPTION QUESTIONNAIRE</b>	248
<b>APPENDIX C</b>	<b>PRE-CASE STUDY INTERVIEW QUESTIONS</b>	258
<b>APPENDIX D</b>	<b>POST-CASE STUDY INTERVIEW QUESTIONS</b>	260

---

**LIST OF FIGURES**

FIGURE 2-1: RENEWABLES-BASED ELECTRICITY GENERATION BY SOURCE AND SHARE OF TOTAL GENERATION IN THE EUROPEAN UNION IN THE NEW POLICIES SCENARIO [1, P.200]	8
FIGURE 2-2: POPULATION OF THE WORLD, 1950-2100, ACCORDING TO DIFFERENT PROJECTIONS AND VARIANTS [15, P.XV]	9
FIGURE 2-3: SHARE OF CHINA AND INDIA IN NET INCREASE IN GLOBAL PRIMARY ENERGY DEMAND BY FUEL AND CO <sub>2</sub> EMISSIONS IN THE NEW POLICIES SCENARIO, 2010-2035 [1, P.57]	9
FIGURE 2-4: ENERGY FLOW CHART 2012 [16, P.3]	11
FIGURE 2-5: UK'S DOMESTIC PRIMARY ENERGY CONSUMPTION IN 2012 [3, TABLE 3.02]	12
FIGURE 2-6: UK'S DOMESTIC FINAL ENERGY CONSUMPTION IN 2012 [3, TABLE 3.04]	13
FIGURE 2-7: PROJECTED AGE PROFILE FOR UK DOMESTIC BUILDING STOCK [4, P.5]	14
FIGURE 2-8: MEAN HOURLY ELECTRICITY DEMAND AND PRICES IN 2011 [26, 27]	15
FIGURE 2-9: AVERAGE DAILY ENERGY DEMAND AND PRICE FOR 2011 [26, 27]	15
FIGURE 2-10: MEAN ELECTRICITY DEMAND PER WEEKDAY [26]	16
FIGURE 2-11: AGGREGATED ACTIVE OCCUPANCY FOR ALL SURVEY PARTICIPANTS BY WEEKDAY AND WEEKEND DAYS [29, P.1562]	17
FIGURE 2-12: MEAN DAILY ELECTRICAL USE ACROSS 251 UK HOUSEHOLDS [3, TABLE 3.11]	18
FIGURE 2-13: ENERGY SAVED FOR A TYPICAL HOME THROUGH ADOPTING PHYSICAL AND BEHAVIOURAL ENERGY EFFICIENCY MEASURES [36, P.25]	20
FIGURE 2-14: UK'S DOMESTIC ENERGY CONSUMPTION BY END USE [3, TABLE 3.04]	20
FIGURE 2-15: ELECTRICITY CONSUMPTION OF UK HOUSEHOLDS [3, TABLE 3.10]	21
FIGURE 2-16: LONG-TAIL OF ELECTRICAL ENERGY CONSUMPTION, BASED ON DATA SHOWN IN APPENDIX A [8]	23
FIGURE 3-1: ELECTRICITY PRICING STRATEGIES [54, P.39]	28
FIGURE 3-2: SCHEMATIC OF A CONTROL SYSTEM	31



## LIST OF FIGURES

---

FIGURE 4-1: FLOOR PLANS OF THE HOUSE WITH CO <sub>2</sub> , PIR AND UWB SENSORS	40
FIGURE 4-2: CO <sub>2</sub> CONTENT IN ALL ROOMS VERSUS OVERALL HUMAN PRESENCE	42
FIGURE 4-3: CO <sub>2</sub> CONTENT VERSUS HUMAN PRESENCE IN THE LIVING ROOM	44
FIGURE 4-4: CO <sub>2</sub> CONTENT VERSUS HUMAN PRESENCE IN THE DINING ROOM	44
FIGURE 4-5: CO <sub>2</sub> CONTENT VERSUS HUMAN PRESENCE IN THE FIRST BEDROOM	45
FIGURE 4-6: CO <sub>2</sub> CONTENT VERSUS HUMAN PRESENCE IN THE SECOND BEDROOM	45
FIGURE 4-7: CO <sub>2</sub> CONTENT VERSUS HUMAN PRESENCE IN THE THIRD BEDROOM	46
FIGURE 4-8: PIR MEASUREMENTS IN ALL ROOMS VERSUS OVERALL HUMAN PRESENCE	47
FIGURE 4-9: PIR VALUES VERSUS HUMAN PRESENCE IN THE LIVING ROOM	48
FIGURE 4-10: PIR VALUES VERSUS HUMAN PRESENCE IN THE DINING ROOM	49
FIGURE 4-11: PIR VALUES VERSUS HUMAN PRESENCE IN THE KITCHEN	49
FIGURE 4-12: PIR VALUES VERSUS HUMAN PRESENCE IN THE FIRST BEDROOM	50
FIGURE 4-13: PIR VALUES VERSUS HUMAN PRESENCE IN THE SECOND BEDROOM	50
FIGURE 4-14: PIR VALUES VERSUS HUMAN PRESENCE IN THE THIRD BEDROOM	51
FIGURE 4-15: LQI MEASUREMENTS OF ALL THE JENNET EQUIPMENT VERSUS OVERALL HUMAN PRESENCE	53
FIGURE 4-16: LQI MEASUREMENTS OF TWO PARTICULAR SENSORS VERSUS OVERALL HUMAN PRESENCE	53
FIGURE 6-1: PERSON'S TRAJECTORY IN RELATION TO TX AND RX	69
FIGURE 6-2: CHANNELS 0, 50 AND 255 WITHOUT AN INPUT SIGNAL	70
FIGURE 6-3: CHANNEL 100 WITHOUT AN INPUT SIGNAL	70
FIGURE 6-4: CHANNEL 0 WITH A 0 DBM SIGNAL AND A PERSON CROSSING THE LOS TWICE	71
FIGURE 6-5: CHANNEL 50 WITH A 0 DBM SIGNAL AND A PERSON CROSSING THE LOS TWICE	71
FIGURE 6-6: CHANNEL 100 WITH A 0 DBM SIGNAL AND A PERSON CROSSING THE LOS TWICE	72

## LIST OF FIGURES

---

FIGURE 6-7: CHANNEL 255 WITH A 0 DBM SIGNAL AND A PERSON CROSSING THE LOS TWICE	72
FIGURE 6-8: CHANNEL 0 WITHOUT AND WITH A 12 DBM INPUT SIGNAL	73
FIGURE 6-9: CHANNEL 0 WITHOUT AND WITH A 0 DBM INPUT SIGNAL	73
FIGURE 6-10: CHANNEL 0 WITHOUT AND WITH A -30 DBM INPUT SIGNAL	74
FIGURE 6-11: CHANNEL 0 WITH A 12 DBM INPUT SIGNAL AND A PERSON CROSSING THE LOS TWICE	75
FIGURE 6-12: CHANNEL 0 WITH A 0 DBM INPUT SIGNAL AND A PERSON CROSSING THE LOS TWICE	75
FIGURE 6-13: CHANNEL 0 WITH A -30 DBM INPUT SIGNAL AND A PERSON CROSSING THE LOS TWICE	76
FIGURE 6-14: CHANNEL 0 AT 58 KHZ BANDWIDTH WITHOUT AN INPUT SIGNAL	76
FIGURE 6-15: CHANNEL 0 AT 406.25 KHZ BANDWIDTH WITHOUT AN INPUT SIGNAL	77
FIGURE 6-16: CHANNEL 0 AT 812.5 KHZ BANDWIDTH WITHOUT AN INPUT SIGNAL	77
FIGURE 6-17: CHANNEL 0, 0 DBM, 58 KHZ AND A PERSON CROSSING THE LOS TWICE	78
FIGURE 6-18: CHANNEL 0, 0 DBM, 406.25 KHZ AND A PERSON CROSSING THE LOS TWICE	78
FIGURE 6-19: CHANNEL 0, 0 DBM, 812.5 KHZ AND A PERSON CROSSING THE LOS TWICE	79
FIGURE 6-20: PERSON'S POSITIONS WITH TX AND RX BEING 2 M APART	82
FIGURE 6-21: PERSON'S POSITIONS WITH TX AND RX BEING 4 M APART	82
FIGURE 6-22: MEAN RSS VARIATIONS WITH REGARDS TO PERSON'S POSITION AND RADIO DISTANCES	83
FIGURE 7-1: TELOS B BLOCK DIAGRAM [138, P.1]	88
FIGURE 7-2: AXES ASSIGNED TO TELOS B MOTE	90
FIGURE 7-3: MEAN AND STANDARD DEVIATION OF RSS FOR EACH POSITION DURING ROT-X TEST	91
FIGURE 7-4: MEAN AND STANDARD DEVIATION OF RSS FOR EACH POSITION DURING ROT-Y TEST	92
FIGURE 7-5: MEAN AND STANDARD DEVIATION OF RSS FOR EACH POSITION DURING ROT-Z TEST	92
FIGURE 7-6: MEAN AND STANDARD DEVIATION OF $L_{M2 \rightarrow M1}$ AND $L_{M2 \rightarrow M0}$ FOR $Y = 0^\circ$ AND $Z = 0^\circ$	95

## LIST OF FIGURES

---

FIGURE 7-7: MEAN AND STANDARD DEVIATION OF $L_{M2 \rightarrow M1}$ AND $L_{M2 \rightarrow M0}$ FOR $Y = 90^\circ$ AND $Z = 0^\circ$	96
FIGURE 7-8: MEAN AND STANDARD DEVIATION OF $L_{M2 \rightarrow M1}$ AND $L_{M2 \rightarrow M0}$ FOR $Y = 180^\circ$ AND $Z = 0^\circ$	96
FIGURE 7-9: MEAN AND STANDARD DEVIATION OF $L_{M2 \rightarrow M1}$ AND $L_{M2 \rightarrow M0}$ FOR $Y = 270^\circ$ AND $Z = 0^\circ$	97
FIGURE 7-10: MEAN AND STANDARD DEVIATION OF $L_{M2 \rightarrow M1}$ AND $L_{M2 \rightarrow M0}$ FOR $Y = 0^\circ$ AND $Z = 90^\circ$	97
FIGURE 7-11: MEAN AND STANDARD DEVIATION OF $L_{M2 \rightarrow M1}$ AND $L_{M2 \rightarrow M0}$ FOR $Y = 0^\circ$ AND $Z = 270^\circ$	98
FIGURE 7-12: RSS PER POSITION FOR SETUP-A	101
FIGURE 7-13: RSS PER POSITION FOR SETUP-A(2)	102
FIGURE 7-14: RSS PER POSITION FOR SETUP-B	102
FIGURE 7-15: RSS PER POSITION FOR SETUP-C	103
FIGURE 7-16: MEAN RSS PER OCCUPIED POSITION FOR ALL THREE CONNECTIONS	107
FIGURE 7-17: MEAN RSS PER OCCUPIED POSITION FOR CONNECTION $L_{M1 \rightarrow M0}$	107
FIGURE 7-18: MEAN RSS PER OCCUPIED POSITION FOR CONNECTION $L_{M2 \rightarrow M0}$	108
FIGURE 7-19: MEAN RSS PER OCCUPIED POSITION FOR CONNECTION $L_{M3 \rightarrow M0}$	108
FIGURE 7-20: RSS FOR EACH POSITION A PERSON STOOD IN FOR CONNECTION $L_{M1 \rightarrow M2}$	112
FIGURE 7-21: RSS FOR EACH POSITION A PERSON STOOD IN FOR CONNECTION $L_{M2 \rightarrow M1}$	113
FIGURE 7-22: RSS FOR EACH POSITION A PERSON STOOD IN FOR CONNECTION $L_{M1 \rightarrow M0}$	113
FIGURE 7-23: RSS FOR EACH POSITION A PERSON STOOD IN FOR CONNECTION $L_{M2 \rightarrow M0}$	114
FIGURE 7-24: RSS FOR EACH POSITION A PERSON MOVED IN FOR CONNECTION $L_{M1 \rightarrow M2}$	114
FIGURE 7-25: RSS FOR EACH POSITION A PERSON MOVED IN FOR CONNECTION $L_{M2 \rightarrow M1}$	115
FIGURE 7-26: RSS FOR EACH POSITION A PERSON MOVED IN FOR CONNECTION $L_{M1 \rightarrow M0}$	115
FIGURE 7-27: RSS FOR EACH POSITION A PERSON MOVED IN FOR CONNECTION $L_{M2 \rightarrow M0}$	116
FIGURE 8-1: POSITIONS OF MOTES AND A PERSON IN LAYOUT-A	121
FIGURE 8-2: POSITIONS OF MOTES AND A PERSON IN LAYOUT-B	122
FIGURE 8-3: POSITIONS OF MOTES AND A PERSON IN LAYOUT-C	122

## LIST OF FIGURES

---

FIGURE 8-4: MEAN RSS FOR ALL 16 LINKS, FOR ALL SIX SETUPS AND FOR HUMAN ABSENCE AND PRESENCE	123
FIGURE 8-5: DIFFERENCE BETWEEN PRESENT AND EMPTY RSS VALUES FOR SETUP A1	124
FIGURE 8-6: DIFFERENCE BETWEEN PRESENT AND EMPTY RSS VALUES FOR SETUP A2	124
FIGURE 8-7: DIFFERENCE BETWEEN PRESENT AND EMPTY RSS VALUES FOR SETUP B1	125
FIGURE 8-8: DIFFERENCE BETWEEN PRESENT AND EMPTY RSS VALUES FOR SETUP B2	125
FIGURE 8-9: DIFFERENCE BETWEEN PRESENT AND EMPTY RSS VALUES FOR SETUP C1	126
FIGURE 8-10: DIFFERENCE BETWEEN PRESENT AND EMPTY RSS VALUES FOR SETUP C2	126
FIGURE 8-11: SETUP A1	129
FIGURE 8-12: SETUP AA4	129
FIGURE 8-13: DIFFERENCES AND RANGES OF EMPTY AND PRESENT SCENARIOS FOR SETUP A1	130
FIGURE 8-14: DIFFERENCES AND RANGES OF EMPTY AND PRESENT SCENARIOS FOR SETUP AA3	131
FIGURE 8-15: DIFFERENCES AND RANGES OF EMPTY AND PRESENT SCENARIOS FOR SETUP AA4	131
FIGURE 8-16: SETUP AA3 WITH POSITIONS A TO H	134
FIGURE 8-17: MEAN RSS VALUES OF EMPTY AND POSITIONAL MEASUREMENTS	135
FIGURE 8-18: DIFFERENCE BETWEEN POSITIONAL AND EMPTY MEASUREMENTS	135
FIGURE 8-19: MEAN RSS PER MOTE AND PER SCENARIO	138
FIGURE 8-20: DIFFERENCE BETWEEN VALUES WITH AND WITHOUT SOMEONE PRESENT	138
FIGURE 8-21: SETUP AA3 WITH THE DIFFERENT TRAJECTORIES TAKEN BY THE PERSON	140
FIGURE 8-22: RSS RESPONSE TO A PERSON WALKING ALONG TRAJECTORY X1	141
FIGURE 8-23: RSS RESPONSE TO A PERSON WALKING ALONG TRAJECTORY X2	142
FIGURE 8-24: RSS RESPONSE TO A PERSON WALKING ALONG TRAJECTORY X3	143
FIGURE 8-25: RSS RESPONSE TO A PERSON WALKING ALONG TRAJECTORY Y1	144
FIGURE 9-1: FLOOR PLANS WITH MOTE POSITIONS	149

## LIST OF FIGURES

---

FIGURE 9-2: RSS RESPONSES TO LIVING ROOM OCCUPANCY AT ONE SECOND RESOLUTION	151
FIGURE 9-3: RSS RESPONSES TO DINING ROOM OCCUPANCY AT ONE SECOND RESOLUTION	152
FIGURE 9-4: RSS RESPONSES TO KITCHEN OCCUPANCY AT ONE SECOND RESOLUTION	153
FIGURE 9-5: RSS RESPONSES TO FIRST BEDROOM OCCUPANCY AT ONE SECOND RESOLUTION	154
FIGURE 9-6: RSS RESPONSES TO SECOND BEDROOM OCCUPANCY AT ONE SECOND RESOLUTION	155
FIGURE 9-7: RSS RESPONSES TO BATHROOM OCCUPANCY AT ONE SECOND RESOLUTION	156
FIGURE 9-8: RSS RESPONSES TO LIVING ROOM OCCUPANCY AT ONE MINUTE RESOLUTION	157
FIGURE 9-9: RSS RESPONSES TO DINING ROOM OCCUPANCY AT ONE MINUTE RESOLUTION	158
FIGURE 9-10: RSS RESPONSES TO KITCHEN OCCUPANCY AT ONE MINUTE RESOLUTION	159
FIGURE 9-11: RSS RESPONSES TO FIRST BEDROOM OCCUPANCY AT ONE MINUTE RESOLUTION	160
FIGURE 9-12: RSS RESPONSES TO SECOND BEDROOM OCCUPANCY AT ONE MINUTE RESOLUTION	161
FIGURE 9-13: RSS RESPONSES TO BATHROOM OCCUPANCY AT ONE MINUTE RESOLUTION	162
FIGURE 9-14: RSS RESPONSES TO LIVING ROOM OCCUPANCY AT TEN MINUTE RESOLUTION	163
FIGURE 9-15: RSS RESPONSES TO DINING ROOM OCCUPANCY AT TEN MINUTE RESOLUTION	164
FIGURE 9-16: RSS RESPONSES TO KITCHEN OCCUPANCY AT TEN MINUTE RESOLUTION	165
FIGURE 9-17: RSS RESPONSES TO FIRST BEDROOM OCCUPANCY AT TEN MINUTE RESOLUTION	166
FIGURE 9-18: RSS RESPONSES TO SECOND BEDROOM OCCUPANCY AT TEN MINUTE RESOLUTION	167
FIGURE 9-19: RSS RESPONSES TO BATHROOM OCCUPANCY AT TEN MINUTE RESOLUTION	168
FIGURE 10-1: PERCEIVED ENERGY PRICES IN RELATION TO REPORTED ENERGY SAVING MEASURES TAKEN	177
FIGURE 10-2: PERMISSIONS TO LET AUTOMATED SYSTEMS HANDLE ENERGY SAVINGS IN RELATION TO TRUST	182
FIGURE 10-3: PREFERENCES WITH REGARDS TO OCCUPANT AND AUTOMATION CONTROL MEASURES	182

## LIST OF FIGURES

---

FIGURE 10-4: ACCEPTANCE LEVELS OF TRACKING AND DFL HEALTH CONCERNS	186
FIGURE 10-5: DATA VISIBILITY AND INDOOR TRACKING METHOD PREFERENCES	188
FIGURE 10-6: EXPECTED PAYBACK PERIOD OF ENERGY SAVING SYSTEM WITH DFL IN RELATION TO PERCEIVED ENERGY PRICES	189
FIGURE 11-1: A DAY'S PRICING SCHEME DEDUCED FROM ITS DEMAND RATIO [26,27]	199
FIGURE 11-2: BASF – WEBSITE ONLY – CASE STUDY	206
FIGURE 11-3: BASF – TABLET – CASE STUDY	207
FIGURE 11-4: TARMAC 10 – TABLET – CASE STUDY	208
FIGURE 11-5: TARMAC 10 – OVERRIDE SWITCH – CASE STUDY	209
FIGURE 11-6: TARMAC 12 – WEBSITE ONLY – CASE STUDY	210
FIGURE 11-7: TARMAC 12 – OVERRIDE SWITCH – CASE STUDY	211

**LIST OF TABLES**

TABLE 4-1:	ACTUAL ROOM OCCUPANCY AND ADDITIONAL CIRCUMSTANCES	40
TABLE 6-1:	DIFFERENCE BETWEEN TRANSMITTED AND RECEIVED POWER LEVELS	74
TABLE 6-2:	RSS VALUES FOR DIFFERENT POSITIONS OF HUMAN AND RADIOS	83
TABLE 7-1:	MEAN RSS MEASUREMENTS FOR ROT-X, ROT-Y AND ROT-Z TESTS	91
TABLE 7-2:	STANDARD DEVIATION OF RSS MEASUREMENTS FOR ROT-X, ROT-Y AND ROT-Z TESTS	91
TABLE 7-3:	DIFFERENCE BETWEEN $L_{M1 \rightarrow M2}$ 'S AND $L_{M2 \rightarrow M1}$ 'S MEAN AND STANDARD DEVIATION	95
TABLE 7-4:	DIFFERENCE BETWEEN SETUP-A AND SETUP-A(2)	103
TABLE 7-5:	DIFFERENCE BETWEEN SETUP-A AND SETUP-B	103
TABLE 7-6:	DIFFERENCE BETWEEN SETUP-A AND SETUP-C	104
TABLE 7-7:	MEAN RSS DIFFERENCE WITH AND WITHOUT HUMAN PRESENCE FOR ALL THREE LINKS	109
TABLE 7-8:	RSS DIFFERENCE WITH AND WITHOUT HUMAN PRESENCE FOR $L_{M1 \rightarrow M0}$	109
TABLE 7-9:	RSS DIFFERENCE WITH AND WITHOUT HUMAN PRESENCE FOR $L_{M2 \rightarrow M0}$	109
TABLE 7-10:	RSS DIFFERENCE WITH AND WITHOUT HUMAN PRESENCE FOR $L_{M3 \rightarrow M0}$	109
TABLE 7-11:	DIFFERENCE BETWEEN IMMOBILE AND MOBILE RSS VALUES FOR $L_{M1 \rightarrow M2}$	116
TABLE 7-12:	DIFFERENCE BETWEEN IMMOBILE AND MOBILE RSS VALUES FOR $L_{M2 \rightarrow M1}$	116
TABLE 7-13:	DIFFERENCE BETWEEN IMMOBILE AND MOBILE RSS VALUES FOR $L_{M1 \rightarrow M0}$	117
TABLE 7-14:	DIFFERENCE BETWEEN IMMOBILE AND MOBILE RSS VALUES FOR $L_{M2 \rightarrow M0}$	117
TABLE 8-1:	MEAN RSS VALUES AND DIFFERENCES PER SCENARIO AND PER SETUP	132
TABLE 10-1:	COMMENTS RELATED TO WHETHER PARTICIPANTS WOULD LET AN AUTOMATED SYSTEM HANDLE POTENTIAL ENERGY SAVINGS IN THEIR HOUSE	178

## LIST OF TABLES

---

TABLE 10-2: COMMENTS RELATED TO WHETHER PARTICIPANTS GENERALLY TRUST AUTOMATED SYSTEMS TO MAKE THE RIGHT DECISIONS	180
TABLE 10-3: COMMENTS RELATED TO OCCUPANT OR AUTOMATION CONTROL MEASURES	183
TABLE 10-4: COMMENTS RELATED TO TRACKING ACCEPTANCE LEVELS AND DFL HEALTH CONCERNS	186
TABLE 10-5: INDOOR TRACKING DATA VISIBILITY PREFERENCES	188
TABLE 11-1: DETAILS OF THE CASE STUDIES	201



## **GLOSSARY**

CO <sub>2</sub>	Carbon Dioxide
COAC	Combined Occupant and Automation Control
CPP	Critical Peak Pricing
DfL	Device-free Localisation
DSM	Demand Side Management
L <sub>MX-&gt;MY</sub>	Link during which Mote "X" transmitted to Mote "Y"
LOS	Line Of Sight
LQI	Link Quality Indicator
Mtoe	Million tonnes of oil equivalent
MVHR	Mechanical Ventilation with Heat Recovery
MX	Mote "X", where "X" is a numerical value
PIR	Passive Infra-Red
RSS	Received Signal Strength
RTP	Real-Time Pricing
RX	Receiver
TOU	Time Of Use pricing
TX	Transmitter
UWB	Ultra-WideBand

# 1 INTRODUCTION

## 1.1 TOPIC BACKGROUND

Worldwide, the majority of energy is being consumed in buildings, i.e. over 40 percent in 2010 [1]. 32 percent of the UK's primary energy was used by the domestic sector in 2012 [2]. Transforming primary energy sources, such as coal, gas or oil, into secondary energy, such as electricity, does not only create a large amount of conversion and distribution losses, it also produces greenhouse gases, which accelerate the existence threatening global warming process.

A transition towards sustainable energy sources has therefore been initiated by governments. However, there are fears that this could increase the unpredictability of energy supply as the majority of renewable energy sources are highly weather dependent. Simultaneously, energy demand is rapidly increasing [1]. Hence, additional energy conservation measures are required.

With space heating being the dominant end use in domestic consumption [3], recent efforts were focused on increasing its efficiency, which were predominantly of structural nature. However, the existing building stock is only steadily being regenerated [4], and retrofitted improvements are not as effective [5]. Operational conservation measures are therefore necessary.

A consequence of implementing these structural measures is that the share of energy used for lighting and appliances will rise in relation to total demand. This will be further accelerated by the constant increase of devices per household [6] combined with an increase in the number of UK households [7].

Currently, between 5 and 25 percent of domestic electrical energy is being wasted by leaving appliances in standby operation [8-11]. In addition, according to the same studies, households could reduce their electrical energy consumption by 14 to 42 percent if they replaced their appliances with more efficient ones.

Furthermore, there are additional potential savings on the electrical energy supplying side. With domestic energy demand being uncontrollable, less efficient emergency capacities are used to compensate for any fluctuations [2]. Also, sudden variations in energy supply, for example introduced by weather dependent sustainable energy sources, cannot be counterbalanced.

The reasons these savings are not being made are numerous. On one hand, occupants are lacking awareness of their consumption patterns and hence any potential savings, due to the invisibility of electricity. Also, the effort to benefit ratio of managing the increasing amount of household appliances manually might seem unattractive. On the other hand, energy suppliers have no means by which they could interface or manage domestic energy demand.

Numerous operational energy saving methods have therefore recently been proposed, which can be classified into: "occupant control" and "automation control".

Occupant control measures are designed to empower the user with specific tools in order to change their behaviour and thus help them cut their consumption themselves.

In contrast, automation control measures suggest the use of special equipment powered by a computational logic, which manages the consumption directly.

However, both of the control methods have their drawbacks.

Occupant control is highly individual dependent and often requires special equipment; whilst automation control, which is solely based on special equipment, has often difficulties to identify energy saving potential.

Hence, to achieve maximal savings, this thesis suggests that both of those methods should be combined into one, called Combined Occupant and Automation Control (COAC). It also demonstrates that a form of occupant detection technology will be required for this purpose.

## 1.2 AIM, OBJECTIVES AND METHODS

The aim of this thesis is to enable the implementation of COAC systems by investigating an appropriate occupant detection technology and understanding arising human behaviours.

The objectives necessary to attain this aim are listed below, along with the methods employed to realise them:

1. Identify an occupant detection technology, which is applicable to dwellings and fulfils the requirements imposed by the COAC system

The criteria, set out by this objective, were established and three occupant detection technologies, which met those, were identified: Passive Infra-Red (PIR), Carbon Dioxide (CO<sub>2</sub>) and Device-free Localisation (DfL). Subsequently, an extensive comparison was performed to review their abilities, especially with respect to occupancy detection, localisation and tracking of one or multiple occupants. The findings demonstrated that DfL had the greatest potential, which in conjunction with other beneficial factors qualified it for the required task.

2. Assess the chosen technology's capabilities with regard to its intended application to COAC systems

With DfL being an emerging technology, an initial feasibility study was undertaken. Besides confirming previous research, it was designed to explore DfL's boundaries. However, the available equipment was proven to limit the range of potential experiments due to its inherent characteristics. Hence, other equipment was used for the comprehensive study, whose purpose was to analyse the various technical characteristics impacting the successful integration of DfL and a potential COAC system. This was achieved by the use of numerous, self-contained tests, which gradually built upon each other.

3. Investigate the public's perception of indoor localisation and energy saving occupant control and automation control methods

A questionnaire study was designed for this purpose. It assessed people's current energy saving behaviours and related motivations,

before investigating their views on occupant and automation control methods. Furthermore, their opinions on the chosen DfL technology were evaluated. Particular focus was placed on any potential health, privacy and security concerns, as DfL relies on radio signals.

#### 4. Develop and test a COAC system

For this purpose comparative case studies were conducted as part of the E.ON AG funded SWITCH project [12]. It comprised three dwellings and their participating occupants. The washing machines and dishwashers were automated and connected to a time dependent pricing scheme, which itself was based on the UK's real historical energy demand profile and designed to incentivise energy consumption during low demand periods. Different forms of interfaces, giving the occupants control over the automated appliances, were also assessed. As well as the experimentally collected data, semi-structured interviews were used, which permitted an in-depth analysis of behavioural changes, perceptions, incentives and possible improvements.

### 1.3 CONTRIBUTIONS

The research described in this thesis made contributions to a variety of aspects, including knowledge and practice.

The main contributions to knowledge included:

- Development of the novel concept to integrate COAC and DfL
- Establishment of limitations of PIR and CO<sub>2</sub> based occupant detection technologies
- Establishment of radio signal interactions with environments and humans
- Identification and quantification of user acceptance criteria for DfL and COAC implementations

The main contributions to practice included:

- Development of technical guidance for the implementation of DfL with respect to layout and operation
- Demonstration of a COAC prototype based on a time dependent pricing scheme
- Development of essential implementation criteria for COAC systems with regards to human interaction

## 1.4 THESIS SYNOPSIS

A brief summary of the remaining chapters is outlined below to provide an overview of this thesis.

Chapter 2 elaborates on the topic background of energy consumption, trends and saving potential. The review particularly focuses on the implications of households and their occupancy.

Chapter 3 reviews literature dedicated to domestic operational energy saving measures. It furthermore introduces the concept of integrating occupant and automation control methods and outlines its requirements for occupant detection.

Chapter 4 identifies three domestic occupant detection technologies and describes the experimental study used to select the most appropriate one of them.

Chapter 5 reviews literature on the emerging technology DfL, especially in the context of using an automation system's wireless infrastructure to implement it. Additionally, it reviews the health and security aspects of domestic DfL usage.

Chapter 6 describes a feasibility study, which, besides confirming that DfL is possible, investigated its boundaries with regards to equipment settings and human positioning.

Chapter 7, as part of a comprehensive study including chapters 8 and 9, describes a series of experiments, which examined the indoor propagation of radio signals and investigated their relation to DfL.

Chapter 8 continues the mentioned comprehensive study by examining DfL's capabilities to fulfil the requirements outlined by the COAC concept and assesses optimal network layouts for occupant detection.

Chapter 9 completes the comprehensive study by describing an experiment, during which DfL was applied to a two person occupied dwelling, whilst the optimal temporal resolution for COAC integration was examined.

Chapter 10 presents and discusses the finding of a questionnaire study, which assessed participants' views on energy saving methods and indoor localisation using DfL technology. The perception of the

health and security aspects discussed in chapter 5 were also investigated.

Chapter 11 reports on and analyses the findings of the E.ON AG funded SWITCH project [12], which conducted six comparative case studies in three occupied dwellings by implementing a COAC system using three different types of user interfaces.

Chapter 12 concludes the thesis by discussing the various findings with regards to the overall aim and suggesting future research directions.

## **2 ENERGY AND BUILDINGS**

### **2.1 INTRODUCTION**

The topic background, mentioned in chapter 1, was discussed in more detail to form part of the research question of this thesis. Energy production, consumption, legislation as well as likely trends were reviewed, particularly with regards to buildings and their occupancy. Incentives for energy providers and households to save energy were outlined. Additionally, the concerned energy saving potential was quantified.

### **2.2 ENERGY CONSUMPTION AND TRENDS**

#### **2.2.1 GLOBAL**

Global warming is one of the world's most pressing problems. Greenhouse gases, such as CO<sub>2</sub>, are the main causes and in response governments worldwide have committed to reduce their emissions. The UK, for example, set their target in the "Climate Change Act 2008" [13] to an 80 percent reduction by 2050 in comparison to a 1990 baseline. DeCanio and Fremstad [14] reviewed several papers, which suggested that achieving zero net emissions worldwide by 2050 is economically plausible and estimated the cost to be between one and three percent of the global gross domestic product, also known as GDP.

In order to accomplish this, governments need to reduce their reliance on fossil fuels, especially for the generation of electricity, as they release significant quantities of CO<sub>2</sub>. Nuclear power is felt by many not to be a replacement option due to issues, ranging from disposing of produced waste to heavy water usage in a climate of increasing water scarcity [1]. Therefore, the main viable alternatives are renewable energy sources, such as wind, photovoltaic or hydropower. The International Energy Agency estimated that if European countries follow their declared commitments, over 42 percent of their electricity generation will be from renewables in 2035 [1], as shown in figure 2-1.



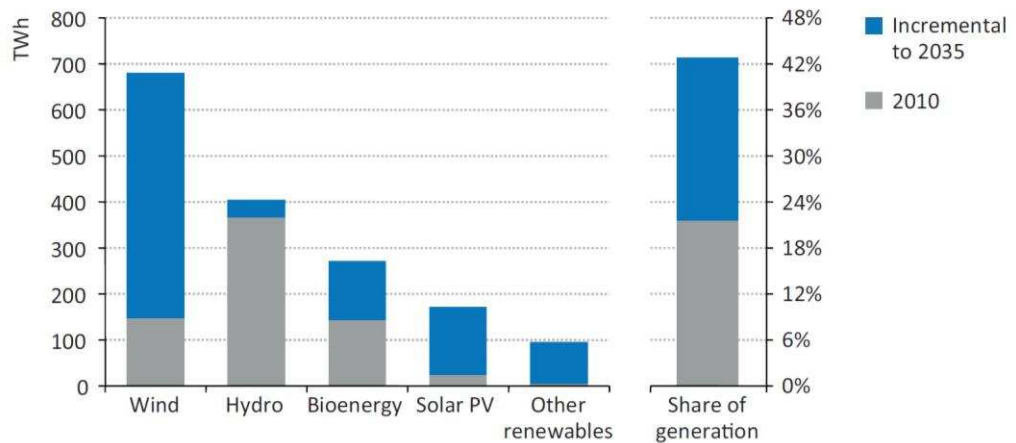

FIGURE 2-1: RENEWABLES-BASED ELECTRICITY GENERATION BY SOURCE AND SHARE OF TOTAL GENERATION IN THE EUROPEAN UNION IN THE NEW POLICIES SCENARIO [1, P.200]

However, it is noteworthy that hydropower supply is not expected to grow considerably. This is due to the specific geographic requirements associated with the operation of hydropower stations. Furthermore, wind and solar photovoltaic power generation are directly dependent on weather conditions and thus, highly variable and hardly controllable. This could strain the power grid and potentially reduce reliability of supply.

On the other hand, the energy demand is constantly rising. The International Energy Agency [1] predicted a mean global energy demand growth of approximately 1.2 percent per year. One factor influencing this is the increasing global population. As presented in figure 2-2, the United Nations [15] estimated the world population to reach 8.7 billion by 2035 and 9.6 billion people by 2050.

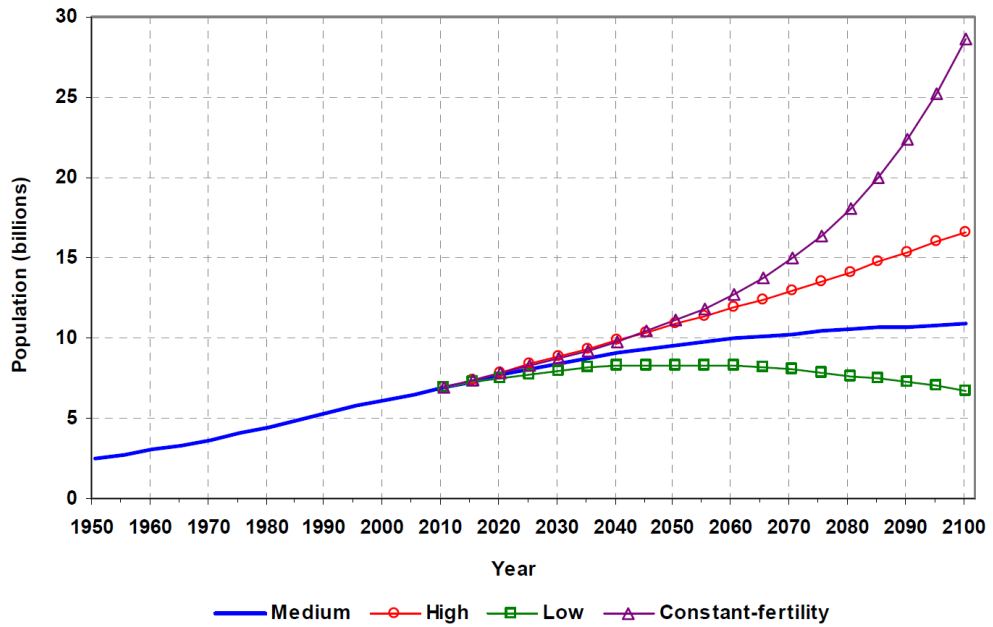

FIGURE 2-2: POPULATION OF THE WORLD, 1950-2100, ACCORDING TO DIFFERENT PROJECTIONS AND VARIANTS [15, P.XV]

Another contributing factor is the expected economic growth of non-OECD countries. The International Energy Agency [1] predicted that 96 percent of the world’s primary energy demand increase between 2010 and 2035 will be down to non-OECD countries, especially China and India. Figure 2-3 highlights the predicted percentage per fuel and per CO<sub>2</sub> emissions attributed to these two countries. Hence, not only a transition in energy supply is required, but also a reduction in energy demand.

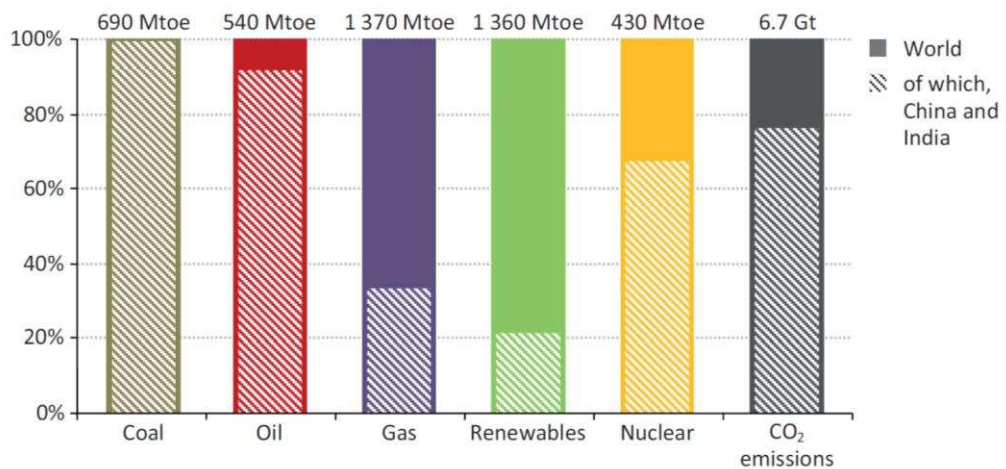

FIGURE 2-3: SHARE OF CHINA AND INDIA IN NET INCREASE IN GLOBAL PRIMARY ENERGY DEMAND BY FUEL AND CO<sub>2</sub> EMISSIONS IN THE NEW POLICIES SCENARIO, 2010-2035 [1, P.57]

### 2.2.2 UNITED KINGDOM

The majority of global energy is being consumed in buildings, followed by industry and transport. In 2010 buildings accounted for over 40 percent of primary energy demand [1]. Similarly, in the UK the domestic sector was the main consumer of primary energy with approximately 32 percent in 2012, which corresponded to 68.5 million tonnes of oil equivalent (Mtoe) [2]. Approximately 43.2 Mtoe of those reached the end consumer, as shown in figure 2-4. It is noteworthy that the substantial conversion losses for generating electricity should be attributed to the respective consuming sectors when comparing them.

CHAPTER 2: ENERGY AND BUILDINGS

Energy Flow Chart 2012  
(million tonnes of oil equivalent)

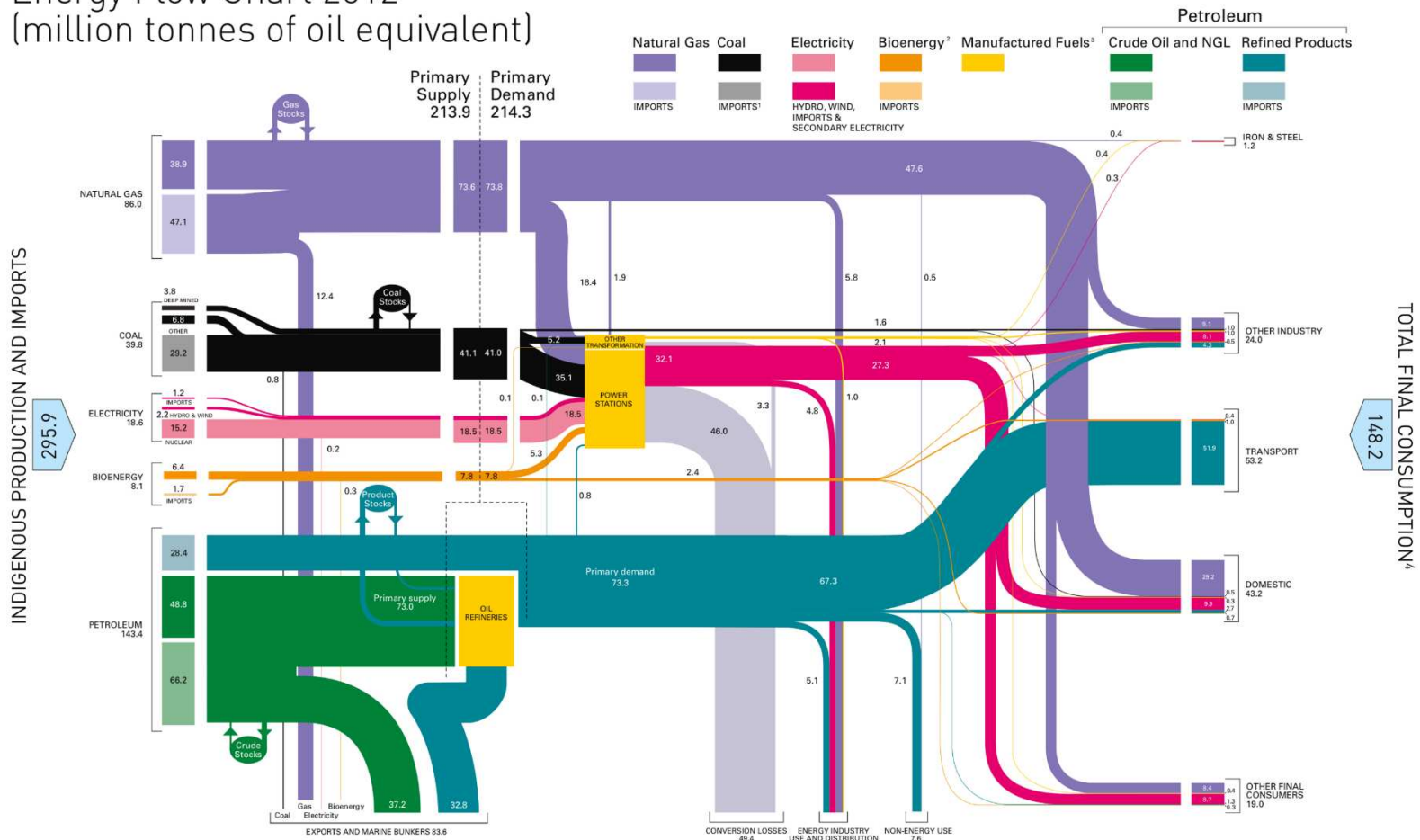

FIGURE 2-4: ENERGY FLOW CHART 2012 [16, P.3]

Also, figure 2-4 highlights the UK's current reliance on fossil fuels to produce electricity. Hence, the UK's energy market regulator Ofgem suggested that there is an elevated risk to the security of electricity supply during the phase out of those fuels in the next few years, especially during the winter 2015 to 2016 [17]. They also expected energy prices to rise, which could impact and worsen the already existing problem of "Fuel Poverty". In 2011 the number of UK households, which had to pay a substantial amount of their income to heat their homes adequately, was between 9 and 12 percent, dependent on the measure used [18]. Besides energy prices, fuel poverty is also exacerbated by poor energy efficient homes and under occupancy [19]. In the UK, space heating is the biggest domestic end use of primary energy, i.e. 53 percent, as shown in figure 2-5. In terms of final energy, i.e. ignoring the conversion losses, it was 66 percent, as shown in figure 2-6.

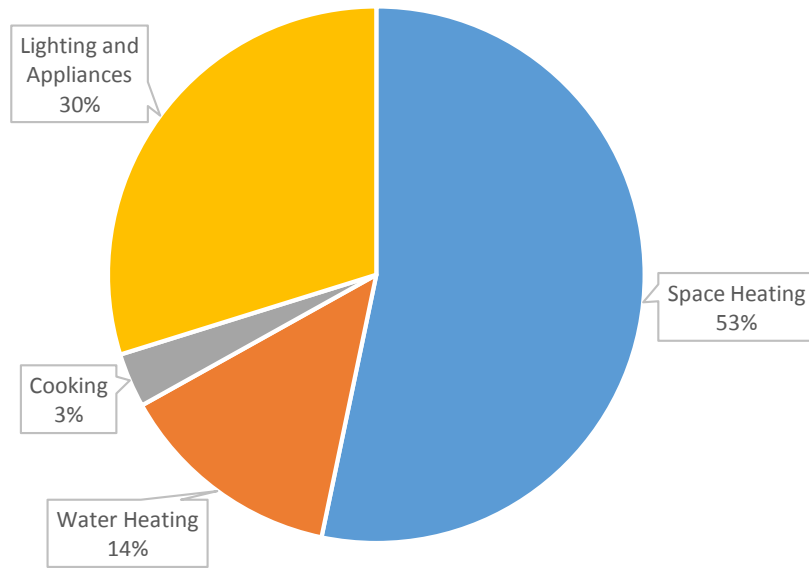

FIGURE 2-5: UK'S DOMESTIC PRIMARY ENERGY CONSUMPTION IN 2012  
[3, TABLE 3.02]

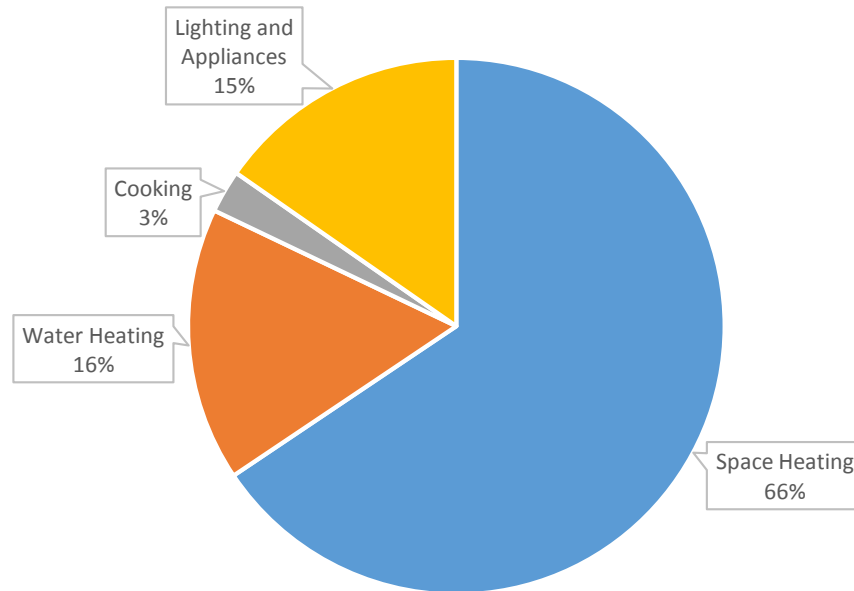

FIGURE 2-6: UK'S DOMESTIC FINAL ENERGY CONSUMPTION IN 2012  
[3, TABLE 3.04]

### 2.3 DOMESTIC ENERGY LEGISLATIONS

To prevent the above mentioned problems and to reduce its CO<sub>2</sub> footprint, the UK government committed itself to very ambitious targets. In December 2006 it announced that all new built homes after 2016 should be "zero carbon" [20], which was again reaffirmed in March 2013 [21]. The term "zero carbon" refers to the highest standard, i.e. six stars, as outlined in the "Code for Sustainable Homes" [22], which effectively requires the dwellings to produce their own energy. In conjunction with this a "Feed-in Tariff" was launched in April 2010 [23], which encourages domestic on-site generation of electricity using renewable energy sources. Other schemes to improve existing homes, such as the "Green Deal" [24], were also introduced.

However, the BRE Trust [4] predicted that the majority of the UK's building stock in 2050 is likely to have been built before 2010, as represented in figure 2-7. In addition, they listed cost-effective improvements, which could be made to existing dwellings, and concluded that even if all of those were implemented and all new dwellings were built to zero carbon standards, the reductions in CO<sub>2</sub> emissions for the domestic sector would be 64 percent, i.e. 16 percent short of the government's target.

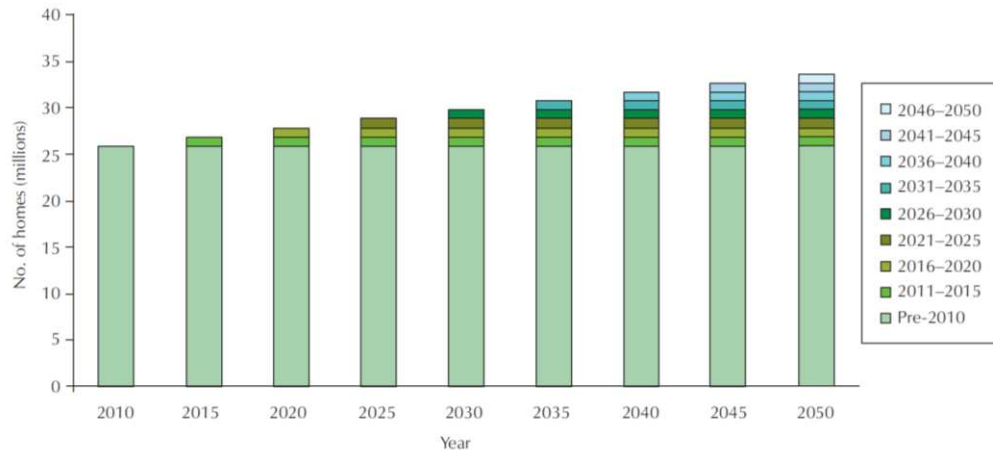

FIGURE 2-7: PROJECTED AGE PROFILE FOR UK DOMESTIC BUILDING STOCK [4, P.5]

Also, Hens [5] explored the increase in energy efficiency of dwellings built in 1957 resulting from the implementation of retrofitted adjustments similar to those proposed by the BRE Trust [4]. The case study concluded that “zero carbon” standards cannot be met using retrofitting in countries like the UK, as some measures are “neither doable nor payable”, and also due to the mismatch between photovoltaic energy generation and the domestic energy demand.

## 2.4 DOMESTIC ENERGY DEMAND REDUCTIONS

### 2.4.1 ENERGY PROVIDERS

Besides increasing energy efficiency or producing energy locally, not requesting energy in the first place would reduce energy demand. The term “negawatt” has been introduced to describe the amount of power that can thus be saved. “The power of negawatts” [25] highlights that building new energy generating capacities costs approximately three times as much as saving the equivalent amount. Therefore, paradoxically, energy providers actually have an incentive to save energy.

Currently, domestic and other energy demands cannot be controlled, as the economic principles of supply and demand do not apply due to fixed energy prices. Hence, energy providers have to compensate for peaks in energy consumption by providing sufficient generation capacities. On average, UK power stations are 38 percent efficient in transforming primary energy into electricity;

however, emergency capacities, which can be deployed relatively quickly, are only approximately 32 percent efficient [2]. This creates the variations in wholesale electricity prices, which are particularly visible during peak demand in figure 2-8. Seasonal variations, which introduce changes in base load demand, as shown in figure 2-9, are more easily predictable and can therefore be accommodated for by power stations with slower reaction times.

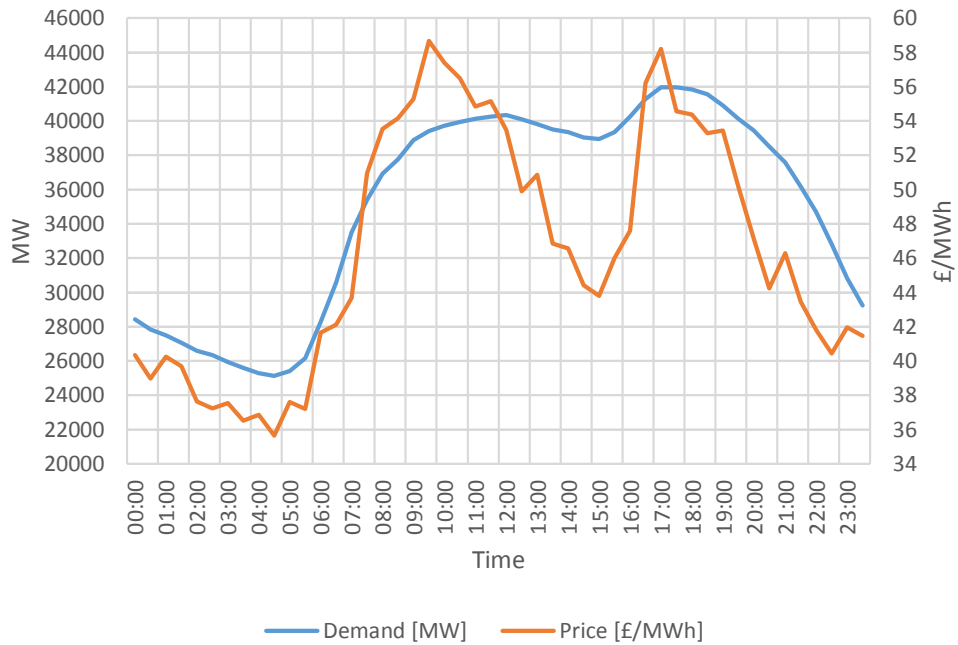

FIGURE 2-8: MEAN HOURLY ELECTRICITY DEMAND AND PRICES IN 2011 [26,27]

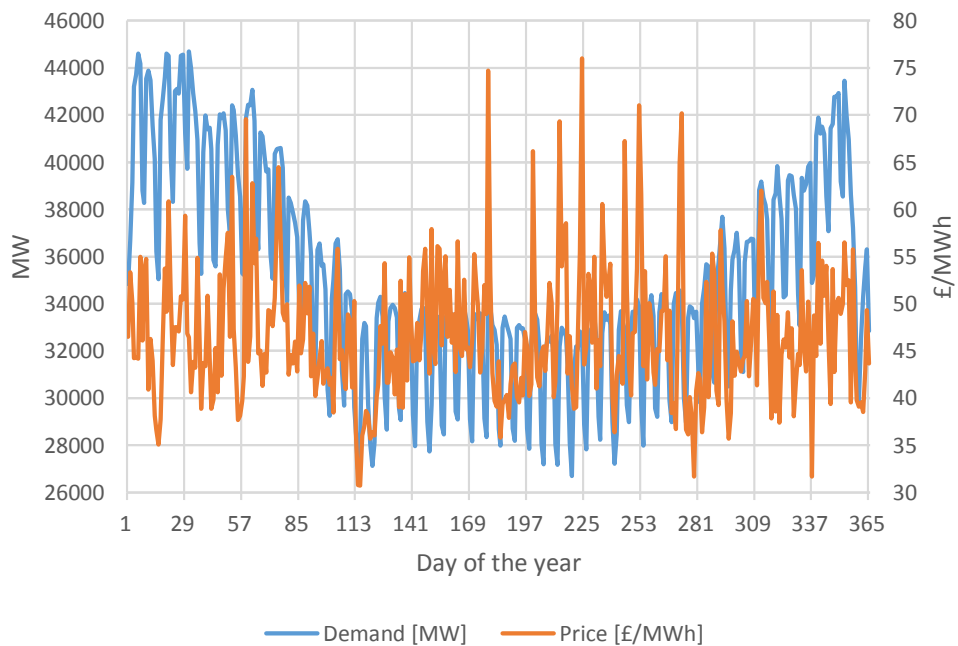

FIGURE 2-9: AVERAGE DAILY ENERGY DEMAND AND PRICE FOR 2011 [26,27]



Calculation made with data obtained from National Grid’s [26] and Exelon’s [27] websites revealed that the daily energy demand varied within  $\pm 36$  percent in 2011. The wholesale energy price on the other hand showed increases of up to 288 percent compared to the daily average. Furthermore, a negative system sell price was recorded in April. Constable and Moroney [28] noted that excessive energy generated by wind farms was the cause. They also highlighted that on several occasions wind farms had to be taken off the grid and compensated for their losses, with prices ranging from 140 to 800 pounds per MWh. With the mentioned increase in electricity production from sustainable energy sources in section 2.2.1 those occasions could become more frequent. Hence, shifting energy demand to avoid peaks or adapting it to excessive energy supply would not only increase the efficiency of generating electricity, but also create substantial financial savings.

Furthermore, there is considerably less electricity being consumed on weekends compared to weekdays, as shown by the periodically occurring troughs in the demand profile in figure 2-9. Figure 2-10 highlights those difference, demonstrating a reduction in amplitude and a shift in time of energy demand on non-working days. The reduction is due to the resting of industry operations. The shift in time, however, is likely to be the accumulated result of the population’s individual behavioural changes on weekends.

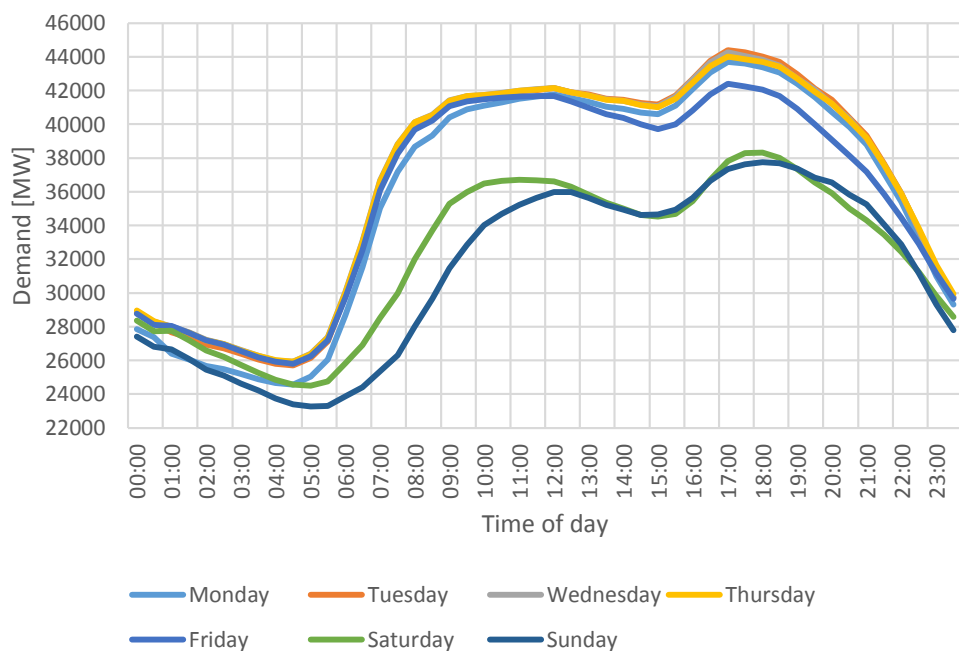

FIGURE 2-10: MEAN ELECTRICITY DEMAND PER WEEKDAY [26]

Richardson et al. [29] analysed the data from a time use survey conducted in the UK in 2000 to demonstrate the active occupancy patterns of weekdays and weekends, as shown in figure 2-11. The mentioned shift in time is clearly discernible. In addition, the UK's distinctive electricity demand profile, seen in figure 2-8 and 2-10 is somewhat similar to the occupancy activity pattern shown in figure 2-11.

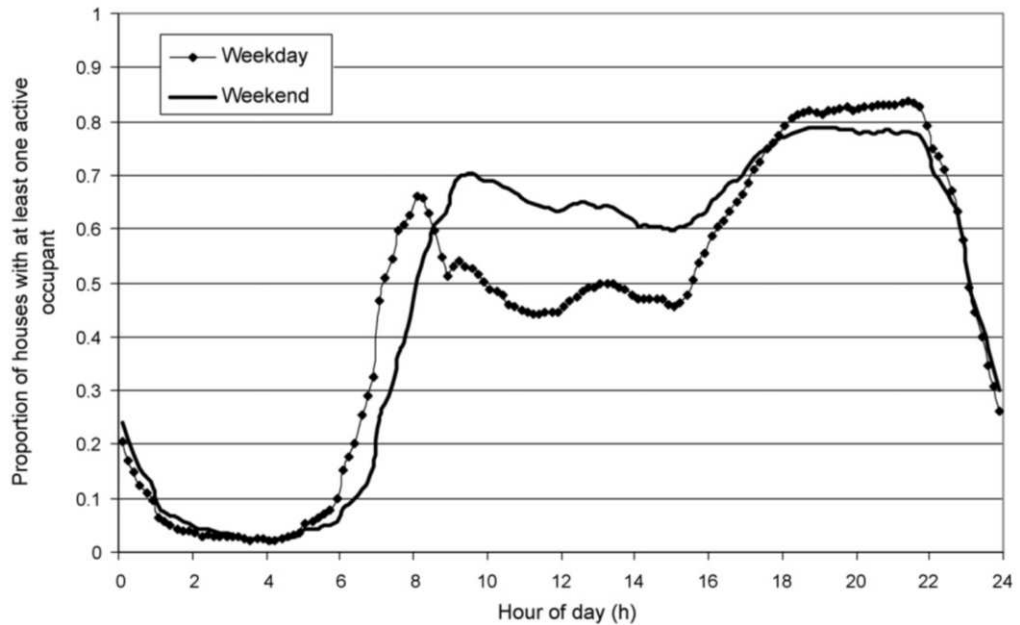

FIGURE 2-11: AGGREGATED ACTIVE OCCUPANCY FOR ALL SURVEY PARTICIPANTS BY WEEKDAY AND WEEKEND DAYS [29, P.1562]

Furthermore, a household electricity use survey was conducted in 251 UK households between 2010 and 2011 [8]. The findings included, amongst others which were mentioned in section 2.4.2, their average daily electrical use, as depicted in figure 2-12. They further support the noticeable relation between the UK's national energy demand and domestic energy demand.

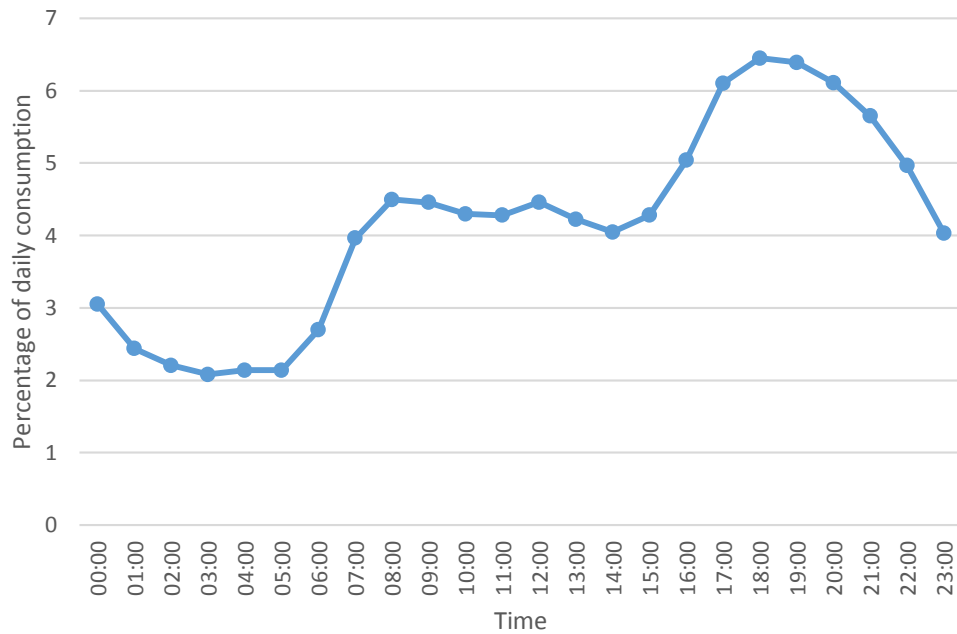

FIGURE 2-12: MEAN DAILY ELECTRICAL USE ACROSS 251 UK HOUSEHOLDS [3, TABLE 3.11]

There have been attempts by energy providers to flatten out the demand profile, and thus exploit the potential savings via the customer, which is called Demand Side Management (DSM). Time dependent electricity retail tariffs, such as “economy 7” and “economy 10” were introduced in the UK [30], which were aimed at households with electrical heating and water storage tanks. However, as people changed to gas central heating, these tariffs became less attractive [31].

A study, which supplied 100 dwellings in South Wales with space and water heating controllers, found that peak demand could be reduced by 25 percent [32]. According to the same report, another study demonstrated that network frequency controlled fridges could account for savings of between 0.70 and 5.60 pounds per annum, which would be equivalent to between 17 and 44 kg of CO<sub>2</sub>. With the 27 million UK households [7] having an average of 1.7 cold appliances [33], this would amount to savings of up to 257 million pounds or 2 million tonnes of CO<sub>2</sub> per year. However, the report [32] also highlighted that the manufacture of such appliances, which would need to be tailored to the UK’s network frequency range, could hinder widespread implementation.

Furthermore, one energy supplier has recently announced plans to supply energy for free on Saturdays to customers with smart meters

in order to outbalance the mismatch between weekdays and weekends described above [34]. Chapter 3 discussed energy tariffs, smart meters and other DSM methods in more detail.

### 2.4.2 HOUSEHOLDS

Even if energy providers do not capitalise on this opportunity, energy consumers have an incentive to save energy. As previously highlighted and demonstrated in figure 2-6, the biggest part of domestic energy use is space heating. However, 74 percent of space heating and 78 percent of water heating in the UK are gas powered [3]. Hence, an average UK household consumed between three to four times as much gas as it did electricity over the past years [35]. On the other hand, the electricity price was three to four times higher than the gas price [7]. Consequently, they spent approximately the same amount of money on both forms of energy, but each kWh of electricity they saved was worth approximately four kWh of gas.

Figure 2-13 highlights some energy efficiency measures, physical or behavioural, along with the amount of potential energy saved, assumingly per year. However, over 40 percent in the UK in 2010 already owned a condensing boiler and approximately one third of households had "full insulation", with the remaining two thirds having had "some insulation" [7]. Additionally, approximately 50 percent of "cold" and "wet" appliances owned were "A" rated [36]. Therefore, the behavioural savings shown in figure 2-13 are likely to have a more significant and lasting impact.

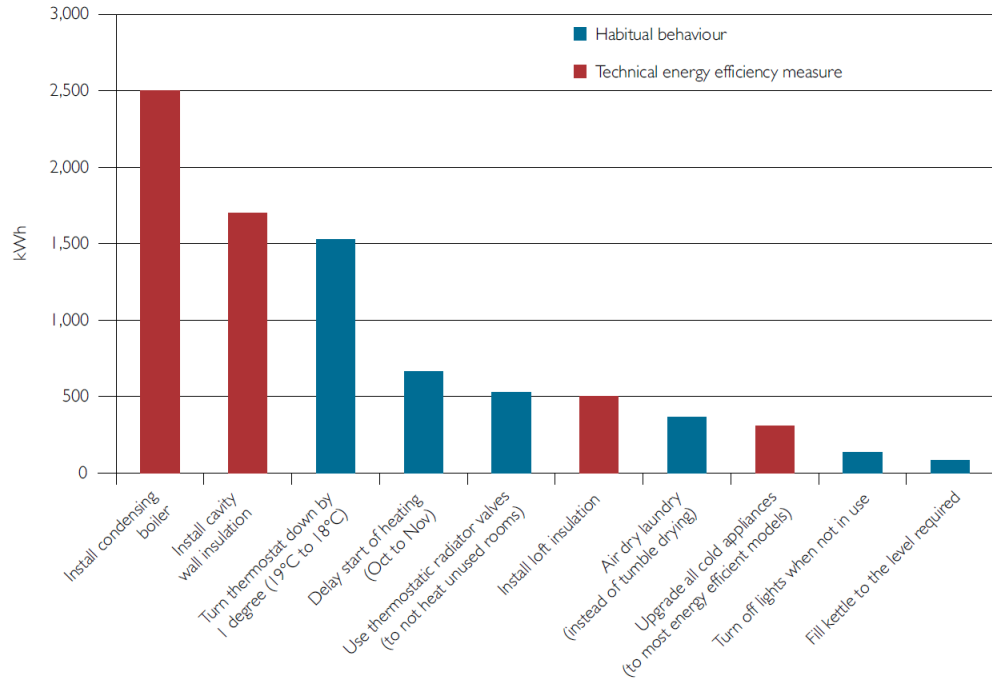

FIGURE 2-13: ENERGY SAVED FOR A TYPICAL HOME THROUGH ADOPTING PHYSICAL AND BEHAVIOURAL ENERGY EFFICIENCY MEASURES [36, P.25]

Furthermore, with the implementation of the previously mentioned ambitions by the UK government to improve energy efficiency of homes, which were mainly targeted at space heating, the percentage of energy consumed by lighting and appliances will increase. Figure 2-14 shows that this trend was apparent over the last decades.

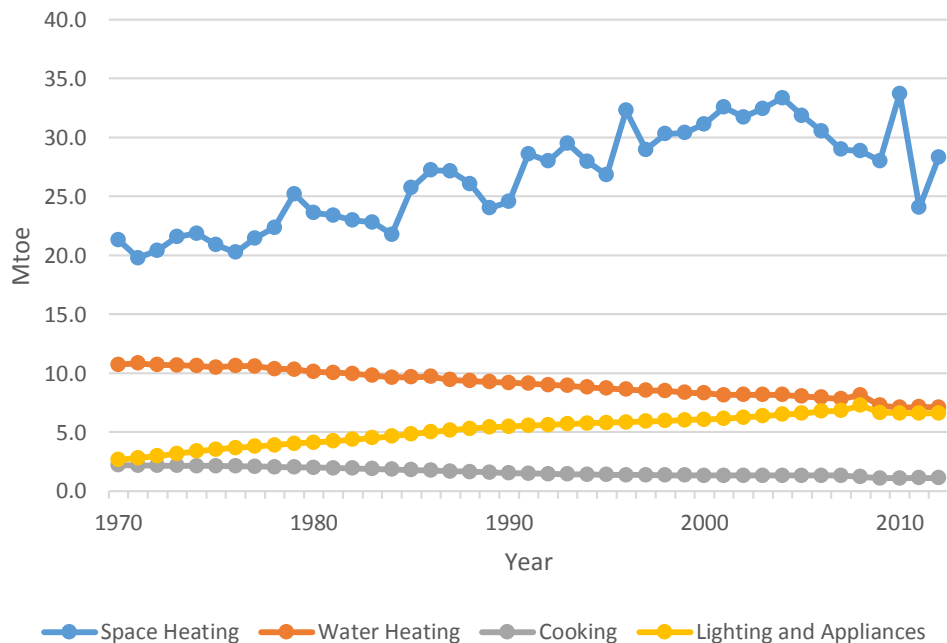

FIGURE 2-14: UK'S DOMESTIC ENERGY CONSUMPTION BY END USE [3, TABLE 3.04]

However, the Energy Saving Trust [37] suggested that the increased number of electronic devices per household and their associated accumulated standby consumption were the main reason. Figure 2-15, which along with figure 2-14 is based on a model, showed that energy consumed by computing devices and consumer electronics has been rising sharply over the same time period.

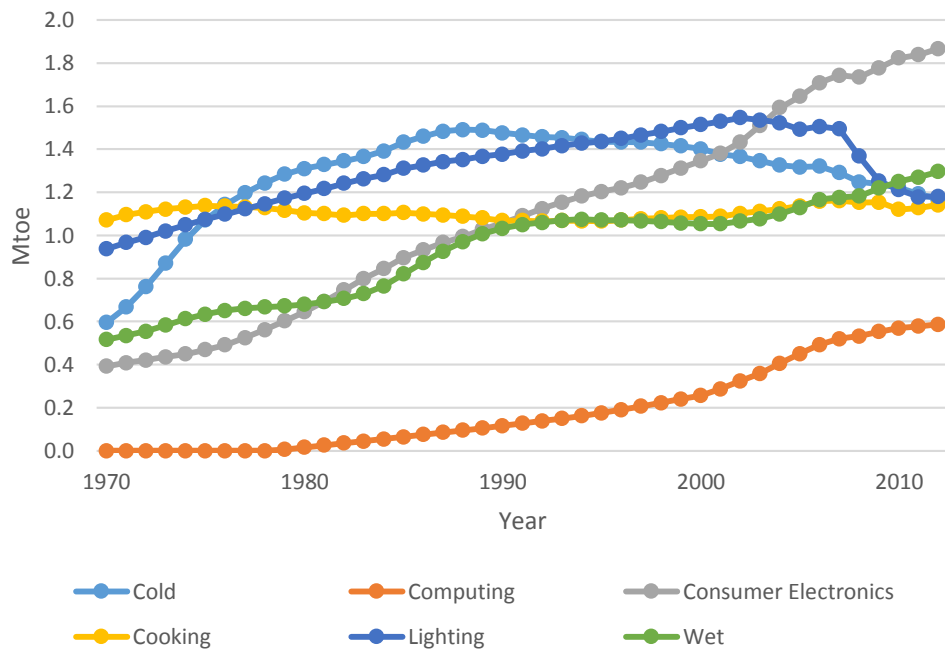

FIGURE 2-15: ELECTRICITY CONSUMPTION OF UK HOUSEHOLDS [3, TABLE 3.10]

Also, projections assume that the number of households rather than the size of the population dictate future trends [6]. This would imply that the consumption associated with these devices could increase very rapidly as the number of people per household has been falling since 1970, even though the population has been growing [7]. This assumption has additionally been supported by the findings of the “Household Electricity Use Study” [8], as it showed that the energy consumed per person was significantly lower in shared households. Even in absolute terms the study outlined numerous cases of single occupied households consuming more energy than multiple occupied households. Besides, suggesting that some resources can only accommodate a certain number of people, this indicates that household dynamics might influence energy consumption behaviour.

Furthermore, the “Household Electricity Use Study” [8], which collected data from 251 demographically representative UK

households between 2010 and 2011, suggested that between 9 and 16 percent of the average domestic electricity consumption was due to appliances in "standby mode" [33]. Zimmermann et al. [8], who analysed the same data, demonstrated that between 15 and 20 percent of domestic electrical energy demand can be saved, if appliances were replaced with more efficient ones which simultaneously consume less standby power. Both reports [8,33] also listed the annual consumption of monitored household appliances and estimated the saving potential of some. The corresponding figures, classified into "cold", "computing", "consumer electronics", "cooking", "lighting", "other", "water heating" and "wet", are represented in appendix A along with their estimated operating costs.

The findings of another study [9], which monitored 400 houses and apartments in Sweden, found that appliances in standby consumed between 517 and 1016 kWh in houses and between 298 and 420 kWh in apartments. This meant that dwellings could save between 5 and 25 percent of their consumption. The report also showed that households could save between 14 and 42 percent, if they replaced appliances, lighting and reduced standby powers to less than 0.5 Watt.

A similar study [10], which monitored 375 households across Denmark, Greece, Italy and Portugal, suggested that between 8 to 14 percent of electrical energy could be saved by reducing standby consumption. They also estimated that these savings would more than double if "cold" and "wet" appliances, as well as lighting, would be replaced with more efficient counterparts.

The REMODECE project [11], which monitored 1300 households across 12 EU countries, found that appliances in standby accounted for 11 percent of the average household's electricity consumption. Furthermore, they suggested that 48 percent of electrical energy could be saved if energy efficient technology and behaviour was used.

The findings of all these mentioned studies are also supported by simulations, such as those made by Meyers et al. [38]. They estimated that between 17 and 26 percent of primary energy is wasted in US homes due to inefficient appliances and standby operation. Furthermore, they suggested that between 16.5 and 36.4

percent of primary domestic energy could be saved if occupants avoided to overset their thermostats, heat unoccupied rooms or vacant houses.

The consistency of all these studies underlines that there is a substantial amount of energy saving potential in dwellings. However, despite the associated financial incentive many households do not take advantage of their saving potential. The consumption pattern created by the amount of consumer electronics and computing devices could be responsible. As shown in figure 2-16, they create a “long-tail” effect where a few appliances consume a lot and many consume little. Hence, occupants could quickly save energy by replacing a few appliances with more efficient ones, but it would require a lot of effort to realise the remaining energy saving potential.

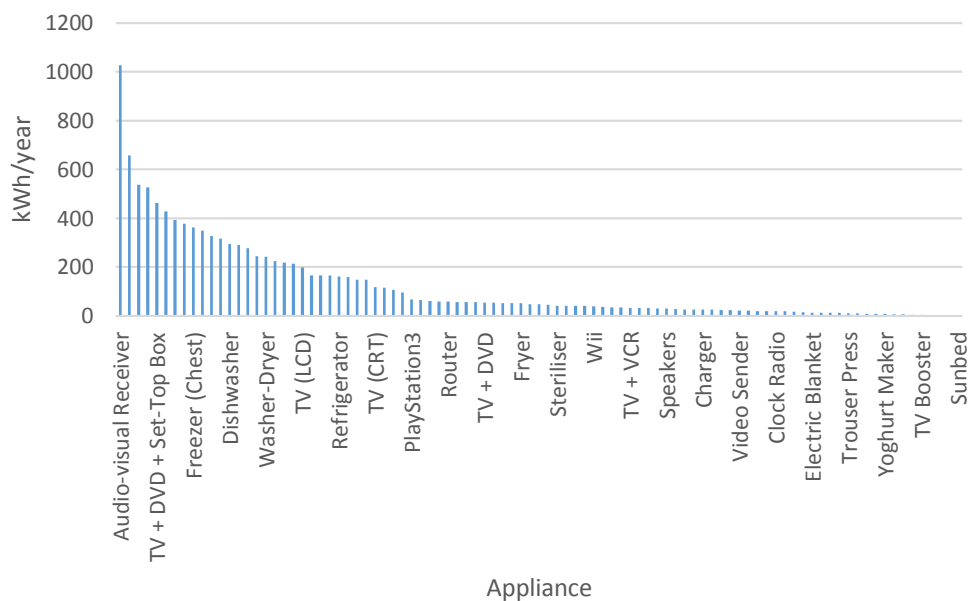

FIGURE 2-16: LONG-TAIL OF ELECTRICAL ENERGY CONSUMPTION, BASED ON DATA SHOWN IN APPENDIX A [8]

The previously mentioned studies [8-11,33] contented themselves with requesting standby powers to be reduced to 0.5 W. However, that are still 4.4 kWh per year per device wasted, which would accumulate on an aggregated level. This thesis outlined and proposed a method in chapter 3 which could exploit the full saving potential. Furthermore, it investigated the remaining reasons for which occupants do not capitalise on their energy saving potential.



## 2.5 CHAPTER CONCLUSION

The importance of domestic energy conservation measures in the light of global warming were outlined. It was demonstrated that operational saving measures are required, besides the existing transitions in energy production and structural energy efficiency measures. The saving potential and incentives for energy providers to reduce or shift energy demand were outlined. Similarly, the saving potential for households was quantified. Furthermore, the relation between occupancy and national energy demand was highlighted as well as the need for DSM methods. Chapter 3 investigated further why households have not been making the described energy savings and elaborated on domestic energy saving measures, including DSM.

## **3 OCCUPANT AND AUTOMATION CONTROL**

### **3.1 INTRODUCTION**

A substantial amount of energy saving potential is available in domestic houses, as highlighted in chapter 2. However, there is not unanimity regarding the question of how to tackle this potential. Some argue that the occupants' behaviours can be influenced in order to steer them towards making the potential savings. Others suggest the use of home automation systems instead. Both these domestic control systems, called "occupant control" and "automation control" respectively, were described and discussed in detail. A combination of those two control methods was then proposed and outlined by this thesis as the most promising option.

### **3.2 OCCUPANT CONTROL**

Occupants, who are the main purpose of domestic energy consumption, are generally responsible for its demand. Hence, some researchers believe that they are the key to saving this energy. The concept of occupant control is to empower occupants by giving them appropriate tools to change their behaviour, and thus achieve the energy savings outlined in chapter 2. This is especially important as it has been suggested that participants have to develop new habits in order for any energy savings to be persistent [39,40]. The main two types of empowering tools are feedback and incentives, as outlined below.

#### **3.2.1 FEEDBACK**

Currently, energy is largely invisible to the consumer. Usually, the only interfaces are the annual bill, which in itself is confusing to many [41], and energy meters, which are often hidden away or in hardly accessible spaces [42]. Therefore, one method of occupant control is trying to increase the occupant's awareness of their energy consumption. As outlined by Darby [40], feedback is a very effective method for this purpose. It can be classified into "direct"

and “indirect” feedback; direct feedback being interactive and instantaneous, and indirect feedback being delayed and usually processed information.

Smart meters are a form of direct feedback, which display the energy usage in real-time and provide the energy utilities with readings, thus making estimated billing obsolete. Along with the efforts to reduce CO<sub>2</sub> emissions, the UK government has planned the installation of smart meters in every house. Their rollout will be taking place between 2015 and 2020 [43].

Hargreaves et al. [41] however pointed out that the novelty effect of a smart meter does not last and that occupants will stop using its feedback. They also highlighted that the device’s aesthetics are crucial in it being exhibited or hidden away. Furthermore, Giacomini and Berola [44] found a difference between the emotional response of males and females in relation to energy visualisation methods, suggesting a gender dependent effectiveness.

Additionally, there are concerns that smart meters could potentially increase domestic privacy and security risks [45]. With it reporting energy consumption, any leaked information could be used to determine the occupant’s habits or when the property might be empty.

Other forms of direct feedback could include design features of household devices, as presented by Ernevi et al. [46]. They developed a range of appliances that change shape, colour or other characteristics according to their energy consumption in order to attract the user’s attention. Also, Alahmad et al. [47] recreated a real domestic environment virtually and superimposed the energy usage by highlighting the affected appliances. Both approaches seem to have great potential, however, they require special equipment.

Indirect feedback on the other hand is commonly associated with billing. Online information, which is made available by some energy providers, can also be classified as such. Wilhite and Ling [48] suggested that more frequent billing could increase energy awareness and thus the occupant’s ability to change their behaviour accordingly. Freeman and Gait [49], who conducted a very comprehensive study including direct and indirect feedback methods for gas and electricity consumption, found the most significant

savings were attained using monthly billing. They highlighted that occupants needed to regularly pay those bills, which required them to manage their money accordingly and thus increased their awareness.

Also, the information needs to be presented in an understandable and easily interpretable format. Karjalainen [50] found that the unit of cost over time was preferred to scientific units such as kWh or kgCO<sub>2</sub>. A breakdown by appliance was also desired by their participants. Roberts et al. [51] suggested that comparisons between one's previous and current usage was more appreciated than comparisons with other households. Additionally, their participants were interested in receiving suggestions on how to make further energy savings.

Darby [40], who reviewed several publications, suggested that on average between 5 to 15 percent of domestic energy could be saved using direct feedback methods, and 0 to 10 percent using indirect methods. However, Parker et al. [39], reviewed similar as well as more recent publications and argued that the savings from direct feedback were closer to the region of 2 to 10 percent. They also pointed out that the savings were directly correlated with people's motivations and engagements. Fischer [52], who additionally reviewed non-English publications, suggested that overall savings from feedback were between 5 and 12 percent. However, it needs to be noted that the mentioned figures are averages and that some of the reviewed studies showed no savings as well as more significant ones.

Furthermore, Wood and Newborough's [53] findings suggest that the energy savings made by direct and indirect feedback methods do not necessarily complement each other. In fact, their study, involving electrical cookers of 44 UK households, showed greater savings for direct feedback than direct and indirect feedback combined. Hargreaves et al. [41] on the other hand pointed out that feedback can be empowering for some, but overwhelming for others. However, they also found signs of it leading to energy saving behaviour beyond the domestic setting.

3.2.2 INCENTIVE

Another method of occupant control is to provide occupants with an incentive. This could not only increase occupants' energy awareness, but offer a greater encouragement to act upon it. In section 2.4.1, time dependent electricity pricing schemes were briefly mentioned with regards to DSM. Fox-Penner [54] classified them into three pricing strategies, as shown in figure 3-1: Time Of Use pricing (TOU), Critical Peak Pricing (CPP) and Real-Time Pricing (RTP).

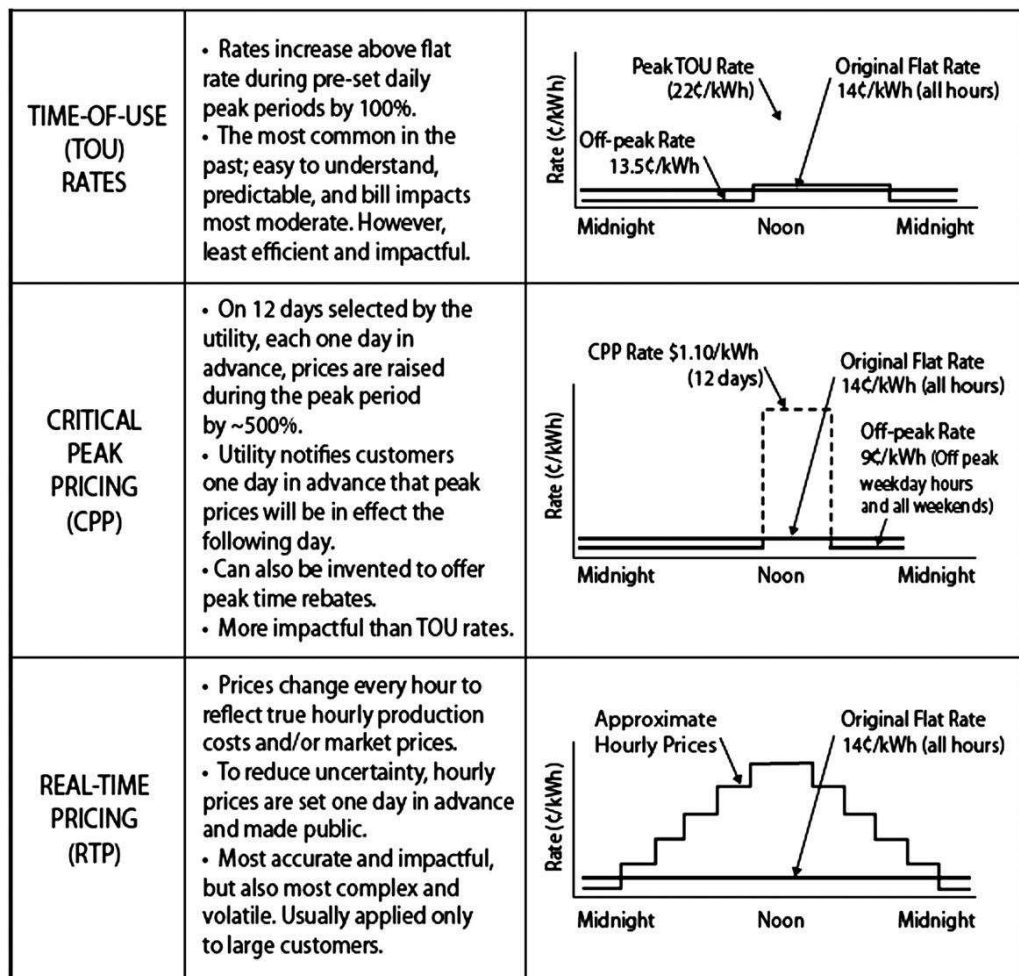

FIGURE 3-1: ELECTRICITY PRICING STRATEGIES [54, P.39]

These schemes are aimed at discouraging electricity consumption during peak hours, thus creating energy savings on the supply side, as explained in section 2.4.1. However, it is noteworthy that some domestic energy demands are highly time specific, as for example the use of an electric kettle. In contrast, other energy demands range over a period of time. For example a Danish pilot project [55]

found that although 55 percent of shifted heating energy were saved, 45 percent were consumed afterwards to reheat the house.

Also, variable pricing schemes could disproportionately encourage consumption during off-peak hours. Especially with schemes that supply free electricity on a single weekday, as contemplated by at least one British energy provider [56]. This could undermine the behavioural changes required to achieve consistent savings.

Faruqui et al. [57] highlighted that variable pricing schemes need to be coupled with smart meters or other energy shifting technology to achieve their full potential. This especially applies to devices, which are not directly controllable by the occupant, such as fridges for example. A pilot scheme in California, which assigned participants TOU or CPP tariffs, with a control group only receiving information, showed average peak demand savings of 14 percent [31]. Some participants, who were given additional technology, achieved up to 18 percent more energy savings than those without [32].

Furthermore, the majority of participants preferred the dynamic pricing rates to existing inverted tier rates [31]. However, in France less than two percent of customers signed up to the “tempo” electricity pricing scheme, which divides each year into 300 cheap, 43 average and 22 expensive days [55]. The report also suggested that the scheme was mainly attractive to people who did not need to change their behaviour to take advantage of it or who could heat with wood or kerosene instead of electricity. Also, Ihab et al. [58] demonstrated that taking up the economy 7 tariff in the UK could actually lead to higher bills, especially for low electricity users such as households in fuel poverty.

Darby [40], who reviewed several pricing scheme studies, suggested that peak demand can be reduced by up to 30 percent. Hence, this type of occupant control has significant potential. However, any pricing schemes need to be designed in a manner, which makes them attractive to a considerable number of households. Chapter 9 evaluates the impact of such a scheme in further detail.

On the other hand, occupants do not always directly pay for the energy they use or have control over their energy tariff, as for example tenants whose rent includes energy consumption. Nonetheless, incentivising occupant control methods could still be

applied. Peschiera and Taylor [59] conducted a study in student halls and showed that presenting energy consumption of peers had a greater influence on reducing consumption than impersonal information.

However, there is some energy, which is attributed to occupants, which is hardly susceptible to occupant control methods. As highlighted by Kyrö et al. [60] shared energy, such as lighting or heating in shared access to flats and apartments, is generally supervised and implemented by housing managers. Hence, the occupant has often no direct control over it, but generally pays indirectly for the consumed energy. Though it could be argued that if house managers use occupant control methods at a personal level, it might influence their professional tasks.

### 3.2.3 CONCLUSION

Occupant control has the advantage of improving the overall energy behaviour of users, which could have a positive impact outside the scope of domestic energy. However, it requires special equipment, such as smart meters, and extra effort to build appropriate platforms to compare neighbouring usage or give tailored advice. Besides, it is likely to only work on willing occupants who are motivated to be proactive regarding their energy consumption. As Kahneman [61] suggested, humans are not rational creatures. Also, for some occupants, such as the elderly for example, actually making the suggested energy savings might prove challenging. Therefore, occupant control cannot be considered a permanent solution in itself.

## 3.3 AUTOMATION CONTROL

Automation control, in contrast to occupant control, directly manages domestic energy consumption via special equipment. There are potential energy savings, which occupants cannot reasonably be expected to make, such as eliminating accumulated standby consumption or manually controlling the heating requirements of each room. In order to make those savings, automation control requires sensors, actuators and controllers. They usually operate in the following manner: information detected by sensors is forwarded to a controller, which determines how to

operate the actuators in order to save energy, as depicted by the schematic in figure 3-2.

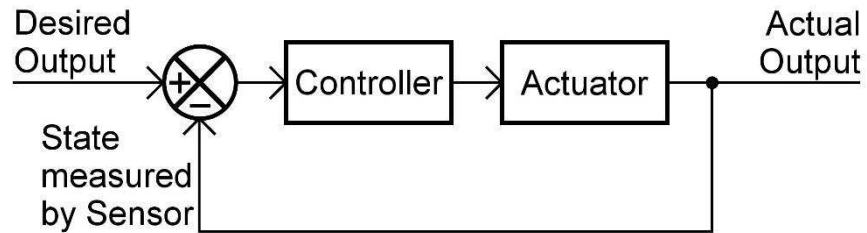

FIGURE 3-2: SCHEMATIC OF A CONTROL SYSTEM

Computers, or other data handling devices, could be part of such a system to enhance its capabilities. The range to which automation control can be applied, was discussed in section 3.3.1, followed by its infrastructure in section 3.3.2 and its human interface in section 3.3.3.

### 3.3.1 APPLICATION METHODS

Automation control has a variety of possible operational enhancements, which could be applied to domestic energy savings. Primarily, it is able to monitor the environment, i.e. temperature, relative humidity, electricity or other fuel usage, etc. It could establish which appliances are being used within a household, as demonstrated by Cox et al. [62]. In addition, automation control systems can determine patterns [63] and predict certain events, such as indoor temperature and humidity [64].

Based on monitored information, automation control systems can then save energy using several methods. For example, tasks could be scheduled to take advantage of available energy, as shown by Abras et al. [65], which might have been produced onsite. This would reduce any transmission losses. Additionally, this type of DSM could be applied in conjunction with the variable pricing schemes mentioned in section 3.2.2 to outbalance the electricity networks demand peaks described in section 2.4.1.

Furthermore, automation control systems can optimise existing technologies. For example a heating controller, which uses learned occupant patterns and temperature preferences to replace the manual programming process, saved 14 percent of water and space heating consumption in experimental trials [32]. In another study, approximately 20 percent of energy used for air-conditioning was



saved with a remote controlled programmable thermostat, which used a 33 percent duty cycle [31].

However, to address the long-tail energy saving potential, outlined in section 2.4.2, technology specific improvements will not suffice. As suggested by Karjalainen and Lappalainen [66] automation control strategies need to be integrated to be more effective.

Furthermore, controlling appliances using external mechanisms might have a limited impact, as some appliances have their own internal control logic, such as washing machines or dishwashers. Hence, for effective DSM and to achieve the greatest energy saving potential, smart appliances are needed, which can interface with pricing schemes or external controllers. Some examples are already being introduced [67].

### 3.3.2 COMMUNICATION

The infrastructure of domestic automated systems can take two forms: wired or wireless.

Wired communication is very reliable. Power line communication [68], amongst others, is a technology that allows the usage of existing wires to transmit information for automation control. However, for any additional equipment, such as sensors or controllers, new cables would need to be laid, which would require extensive work and time. With the UK housing stock changing relatively slowly, as mentioned in section 2.3, the majority of automation control systems would need to be retrofitted.

Wireless communication on the other hand, would be significantly easier and more cost efficient to retrofit. It would also prove advantageous if existing automation systems required upgrading or extending. Wireless equipment is often battery powered though, which can significantly increase its maintenance costs. A solution to this has been offered by at least one technology, which generates energy within the wireless equipment using solar, kinetic or other forms of energy [12]. Besides, wireless charging technology might be used in the future to recharge battery powered devices [69].

A low energy consuming wireless communication technology standard has been developed for the purpose of home automation. The IEEE 802.15.4 standard [70] uses low data rate resolutions

coupled with power management features to increase battery life of equipment. It is aimed at radio operation in personal spaces of up to 10 m. The standard was designed for operating in multiple frequency bands; particularly advantageous are the ranges 868 to 868.6, 902 to 928 and 2400 to 2483.5 MHz as no licence is required to operate in them.

Another possibility would be to use the existing wires in conjunction with wireless equipment by interfacing the two, as demonstrated by Lee and Hong [71]. However, as highlighted by themselves, this would add a great amount of complexity, which could lead to inefficient operation of devices and losses in reliability.

### 3.3.3 HUMAN INTERFACE

The interface between automation control systems and the occupant is crucial. Bordass et al. [72] suggested that if they are poorly designed, the occupants are more likely to misuse the equipment to be controlled, which causes amongst others energy inefficiencies.

Critchley et al. [73] found that controlling the central-heating system was a major problem. They reported that the task was too complicated for some participants and that they therefore either kept the original settings, asked someone else to operate it or switched it on and off manually. Treberspurg et al. [74] also established that the original ventilation and heating settings when occupants moved in, had a significant impact on their overall satisfaction. Furthermore, Revell and Stanton [75] discovered that occupants' mental models of domestic heating systems differed from their actual operation. Norman [76] suggested that interactive systems are learnt more easily if an emotional connection is made.

Occupants' perceived levels of control are also very important to the acceptance of automation control methods, as demonstrated by Toftum [77]. Hence, automated load shifting based on time dependent pricing might not be accepted. Hargreaves et al. [41] confirmed this by stating that even early adopters were sceptical towards such technology.

Other complex relations between humans and automation control systems were pointed out by Parasuraman and Riley [78]. They suggested that over-reliance and mistrust are common issues experienced. However, this is very person dependent as

demonstrated by Merritt et al. [79], who found that implicit preferences as well as propensity towards automation significantly influenced user's trust in automation.

Furthermore, Cole and Brown [80] highlighted that occupants are usually treated as passive variables in the context of indoor climate control. Yet, the occupants' comfort is the energy's purpose. Hence, energy saving automation control systems should integrate them at their core level.

In addition, Endsley [81] emphasised the automation control system operator's importance, i.e. in this case the occupant's, and especially their grasp of their action's impacts. However, the same awareness is required by the automation control system as computational decisions could adversely impact the occupant's comfort. Therefore, as outlined in section 3.4, this thesis suggests the use of an occupant detection technology to allow a greater level of collaboration between the occupant and any respective automation control system.

### 3.3.4 CONCLUSION

Automation control methods are able to make very simple as well as very complex savings. Additionally, they can provide the occupant with greater management options, such as remote control. However, this could lead to an increased energy consumption, for example when used to preheat the house before arrival. Hence, the occupant's behaviour in the context of operating automation control systems remains crucial. Also, similarly to occupant control, automation control relies on special equipment, whose interface might be difficult to handle for some users. Furthermore, automated decisions might interfere with the occupant's comfort, as energy demand varies according to individual choices and needs. Therefore, automation control cannot be considered a permanent solution in itself.

## 3.4 COMBINED OCCUPANT AND AUTOMATION CONTROL

Occupant control and automation control both have their advantages and disadvantages, as mentioned in sections 3.2 and 3.3. This thesis suggests that together they could complement each

other. The concept of COAC was therefore outlined in section 3.4.1 along with the requirements for achieving this integration in section 3.4.2.

### 3.4.1 CONCEPT

Occupant control provides information and incentives, but relies on the occupant to process them and make the savings. Automation control on the other hand provides the capacities to make effortless savings, but often has difficult user interfaces and interferes with occupant's comfort. The integration of both control methods would mean that occupants could make savings, which the automation would not be able to, like choosing not to reheat the kettle water a second time or replacing inefficient appliances; and the automation could tackle savings which are too demanding or complex for occupants, such as switching standby equipment off or adjusting the heating in each room.

Also, several methods mentioned in sections 3.2 and 3.3 have features which inherently allow the combination of occupant and automation control mechanisms, such as variable tariff schemes for example. Klos et al. [82] studied the application of such pricing schemes to domestic air conditioning systems and found that occupants who were given a programmable thermostat, as well as further information, achieved greater savings than those who were only given the information.

Hence, COAC systems would be able to achieve the full range of energy saving potential outlined in chapter 2, including both supply and demand side savings. In addition, occupant and automation control both depend on special equipment, whose costs could be reduced if combined. However, the difficult interfaces and the potential interference of automation control methods with the occupant's comfort remain. A solution to this problem was therefore outlined in section 3.4.2.

### 3.4.2 REQUIREMENT

To properly combine the mentioned control methods and achieve the full domestic energy saving potential, a crucial link is required: the occupant's position.

Occupants cannot make certain savings without reducing their own comfort, which is contradictive to the purpose of domestic energy. Automation control systems on the other hand have the ability, but could interfere with the occupant's activities, which are the decisive indicator of whether energy consumption is wasted or useful. In order to identify this the automation control system would require the occupant's location. Several studies [66,80,83] have highlighted that any integrated control strategies need to be occupant centred.

However, automation control systems can only act upon available information, and there is no realistic method to infer occupancy without the appropriate detection technology. Boait and Rylatt [84], as well as others [85,86], linked energy and water consumption to occupancy. Even though they were able to make some energy savings based on this information, this method is highly illogical as reducing energy consumption would reduce simultaneously the information necessary to make any further savings. Also, whole house occupancy information would only be able to contribute towards some potential savings, others would require at least room level resolution, such as the control of appliances left on standby. Additionally, if the occupant's movements could be monitored, appliances within a certain distance could be switched back on to prevent any potential loss of comfort. An occupant detection technology should also be able to determine these factors for several occupants, because consuming energy is a shared task, as discussed in section 2.4.2.

The information gathered could also be used for occupant control methods. As mentioned in section 3.2, occupants highly value disaggregated energy consumption feedback. Presenting energy consumption in relation to occupancy levels could therefore prove beneficial. In addition, the exploitation of time varying tariffs could be increased by using DSM strategies more effectively. Also, the interface between a COAC system and the occupant could be enhanced by using occupancy information.

However, high importance should be given to the occupants' privacy and security. The two-way communicating smart meters already proved vulnerable, as occupancy levels were deducible [87]. Hence, a domestic occupant detection technology should have the highest possible safety measures in place.

### 3.5 CHAPTER CONCLUSION

It was outlined that a COAC system would be able to achieve greater energy savings than individual occupant and automation control strategies. It was also established that occupancy information would be required for a COAC's successful implementation. Particularly, the location and movement of all occupants would prove beneficial. However, it was stressed that any occupant detection technology should be adequate for the domestic environment by ensuring privacy and security. Chapter 4 elaborated on the requirements for domestic occupant detection technologies and compared a selection of three.

## **4 OCCUPANT DETECTION TECHNOLOGIES**

### **4.1 INTRODUCTION**

COAC systems require occupancy information to achieve their full potential, as outlined in chapter 3. It was also highlighted that occupant detection technologies should have the ability, besides detecting occupancy, to localise and track several occupants without impacting their privacy and security. Other factors, such as visual impact and maintenance costs of any potential domestic detection technology, should also be considered. Additionally, it has to be energy efficient to adhere to the overall goal of conserving energy.

With respect to these criteria several detection technologies can be excluded. Video surveillance for instance would be intrusive; the global positioning system, also known as GPS, is unable to penetrate walls; and radio frequency identification, commonly called RFID, would require occupants to wear tags, which is not only restrictive but highly impractical. Occupant detection technologies should be unobtrusive in a domestic setting. For example underfloor pressure sensors could be used, as demonstrated by Helal et al. [88]. However, they would require costly retrofitting.

For the same reason it was suggested in section 3.3.2 that automation control systems should use wireless infrastructure. However, wireless signals are prone to interference, including interference from human bodies, which reduces their Received Signal Strength (RSS). An emerging technology, called DfL, exploits this phenomenon to detect people [89].

DfL seemed applicable to the domestic environment and was therefore chosen for further investigation, along with two relatively established unobtrusive technologies, based on CO<sub>2</sub> and PIR sensors. All three technologies' abilities to be applied to domestic energy saving COAC systems needed to be assessed. Hence, an extensive comparison with regards to the criteria outlined above and established in section 3.4.2 was undertaken. Particular importance was given to whether the three technologies were able

to determine occupancy, the number of occupants as well as their locations and movements.

## 4.2 METHODOLOGY

A vacant three bedroom dwelling was chosen as a test-bed to compare CO<sub>2</sub>, PIR and DfL occupant detection technologies. It was equipped with wall mounted CO<sub>2</sub> sensors, as represented in figure 4-1, which were positioned approximately half-way between the ceiling and the floor. The house also had PIR sensors fitted to room ceilings, as shown in figure 4-1. In addition, several temperature and humidity sensors were installed throughout the house.

All sensors had embedded Jennic JN5139 modules to wirelessly connect to a data logging system. Their readings were transmitted approximately every four minutes using the proprietary JenNet protocol, which is based on the IEEE 802.15.4 standard mentioned in section 3.3.2 and operates the radio modules at a 2.4 GHz frequency [90]. The Link Quality Indication (LQI) values of each wireless connection, which are linearly related to signal strength, were collected. Also, a "signal sniffer" was used to monitor the network traffic.

Additionally, the house was equipped with a tag based Ultra-WideBand (UWB) tracking system, as shown in figure 4-1. Participants were given an UWB tag, whose position was tracked. This was used as a reference for the other three technologies under examination. Additionally, notes were made of participants' activities and locations.



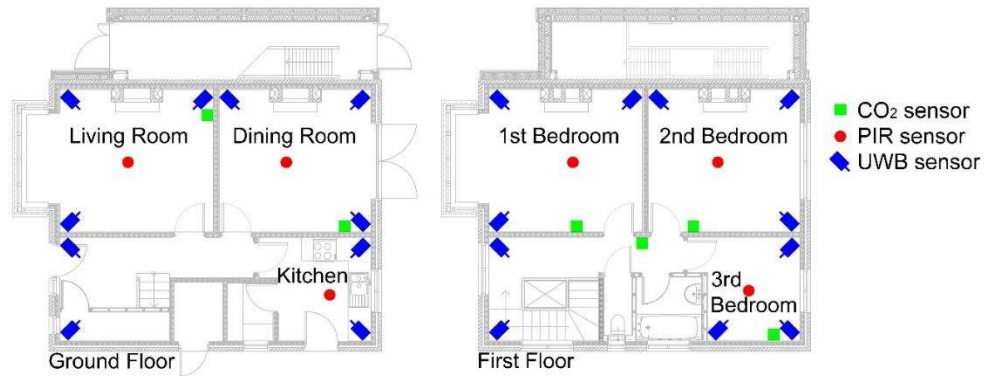

FIGURE 4-1: FLOOR PLANS OF THE HOUSE WITH CO<sub>2</sub>, PIR AND UWB SENSORS

With regards to the CO<sub>2</sub> based detection technology, it is noteworthy that a Mechanical Ventilation with Heat Recovery (MVHR) unit was installed in the house. When in operation it extracted air from the kitchen, bathroom and toilet, and supply fresh air at a constant rate to all living areas, meaning the living room, dining room, first bedroom, second bedroom and third bedroom.

### 4.3 RESULTS

The house was occupied between 10:45 and 18:00 by three participants, referred to as A, B and C. Table 4-1 represents their locations during the experiment. In addition, circumstances which could affect CO<sub>2</sub> or PIR results, were included.

From	To	Room	Participant(s)	Circumstances
10:45	11:00	Living Room	A	
		Dining Room	B	
11:00	12:00	Living Room	A	
		Dining Room	B	
		2 <sup>nd</sup> Bedroom	C	
12:00	13:00	Living Room	A	All interior doors were closed
		Dining Room	B	
		2 <sup>nd</sup> Bedroom	C	

13:00	13:15	2 <sup>nd</sup> Bedroom	C	
	14:00	Dining Room	B	
		1 <sup>st</sup> Bedroom	A	
14:00	14:20	Dining Room	B	
		Kitchen	A	Cooking
14:20	15:00	Dining Room	A, B	
15:00	16:00	Dining Room	A, B	MVHR was on
16:00	17:00	Living Room	A	Window was open
		Dining Room	B	
16:25	17:00	2 <sup>nd</sup> Bedroom	C	
17:00	18:00	Living Room	A	Participant A exercised until 17:30 and all interior doors were closed
		Dining Room	B	
		2 <sup>nd</sup> Bedroom	C	

TABLE 4-1: ACTUAL ROOM OCCUPANCY AND ADDITIONAL CIRCUMSTANCES

#### 4.3.1 CO<sub>2</sub>

The house was unoccupied since approximately 18:00 the previous day, hence the CO<sub>2</sub> content measured at the start of the experiment can be taken as a baseline reference. Figure 4-2 shows that all CO<sub>2</sub> sensors measured between 400 and 500 ppm, which corresponds to typical outdoor CO<sub>2</sub> concentrations.

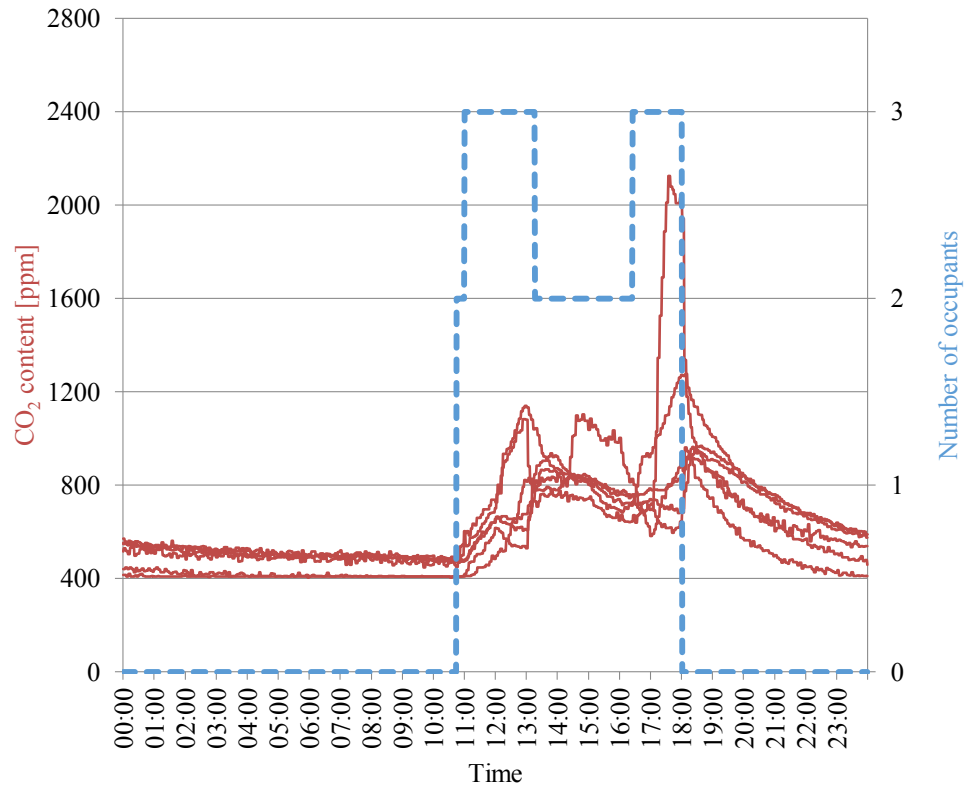

FIGURE 4-2: CO<sub>2</sub> CONTENT IN ALL ROOMS VERSUS OVERALL HUMAN PRESENCE

The CO<sub>2</sub> concentration rose in all rooms after participants A and B entered the house at 10:45, even in unoccupied ones. It was noticed that the average delay in response, which was sensor and position dependent, was approximately 15 minutes.

Once all internal doors were closed at 12:00, the CO<sub>2</sub> content accumulated faster in occupied rooms, as shown in figures 4-3, 4-4 and 4-6. In unoccupied rooms, including the first and third bedroom, the CO<sub>2</sub> concentration stayed constant or dropped, as represented in figures 4-5 and 4-7 respectively.

After the doors were opened again at 13:00, the CO<sub>2</sub> content from the occupied and unoccupied rooms mixed. Hence, it stagnated or decreased in occupied rooms and sharply increased in unoccupied rooms, as the third bedroom for example. This effect could mask occupant movements, such as participant A changing from the living room to the first bedroom.

The MVHR unit was on between 15:00 and 16:00, which reduced the CO<sub>2</sub> levels in all rooms at an increased rate. Even the dining room's levels dropped for approximately 30 minutes before stabilising, although it was occupied by two participants.

At 16:00 participant A returned to the living room and opened a window, which was closed at 17:00 again. This mainly affected the CO<sub>2</sub> content of the ground floor by reducing it further. Surprisingly, the CO<sub>2</sub> concentration in the dining room dropped below the one of the living room, albeit both rooms being occupied by one person. Hence, there might have been an air draught connecting the living room's window with the dining room's French door; near which the dining room's CO<sub>2</sub> sensor was positioned, as shown in figure 4-1.

Between 17:00 and 18:00 all internal doors were closed and participant A did physical exercise in the living room for 30 minutes. This increased the room's CO<sub>2</sub> concentration drastically. Compared to the previous interval of closed doors, it was twice as high in half the time. It was also significantly greater than the CO<sub>2</sub> level in the dining room, when two participants were present between 14:20 and 15:00. However, this cannot be linearly compared due to room size, sensor position and internal door status.

Once participant A stopped exercising, the CO<sub>2</sub> concentration in the living room slightly dropped, which could be related to its particles falling back to the ground. The sharp decrease at 18:00 was due to the opening of all internal doors and the departure of all participants. As previously noted, this resulted in the equalisation of CO<sub>2</sub> concentration throughout the house, which could be misinterpreted as unoccupied rooms being occupied.

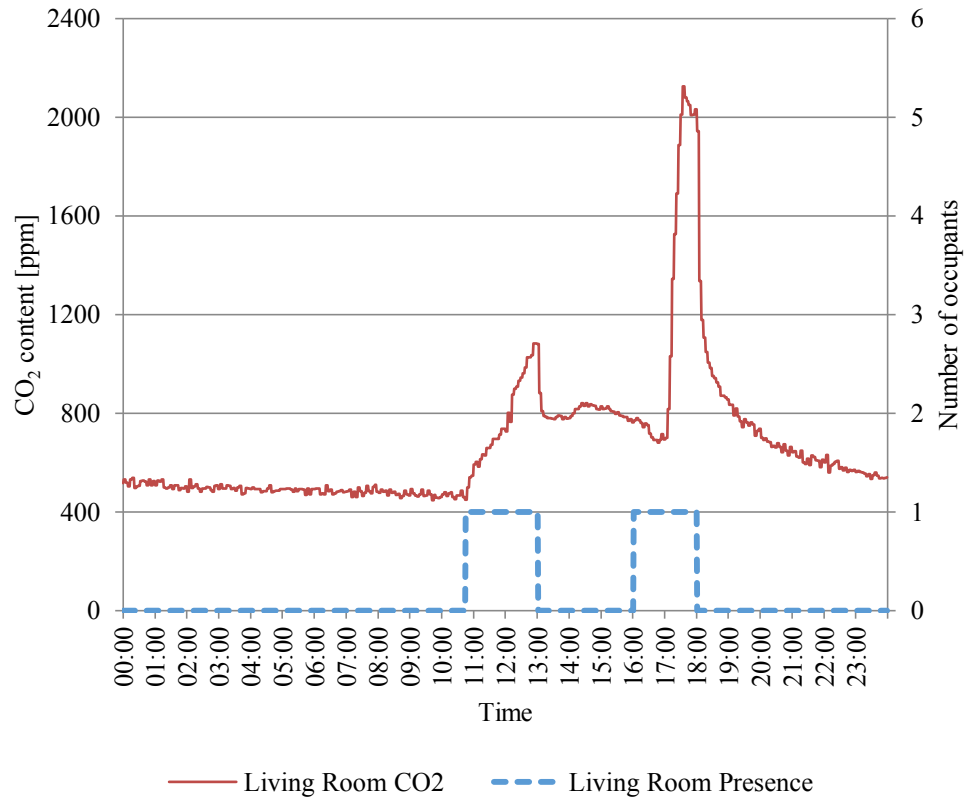

FIGURE 4-3: CO<sub>2</sub> CONTENT VERSUS HUMAN PRESENCE IN THE LIVING ROOM

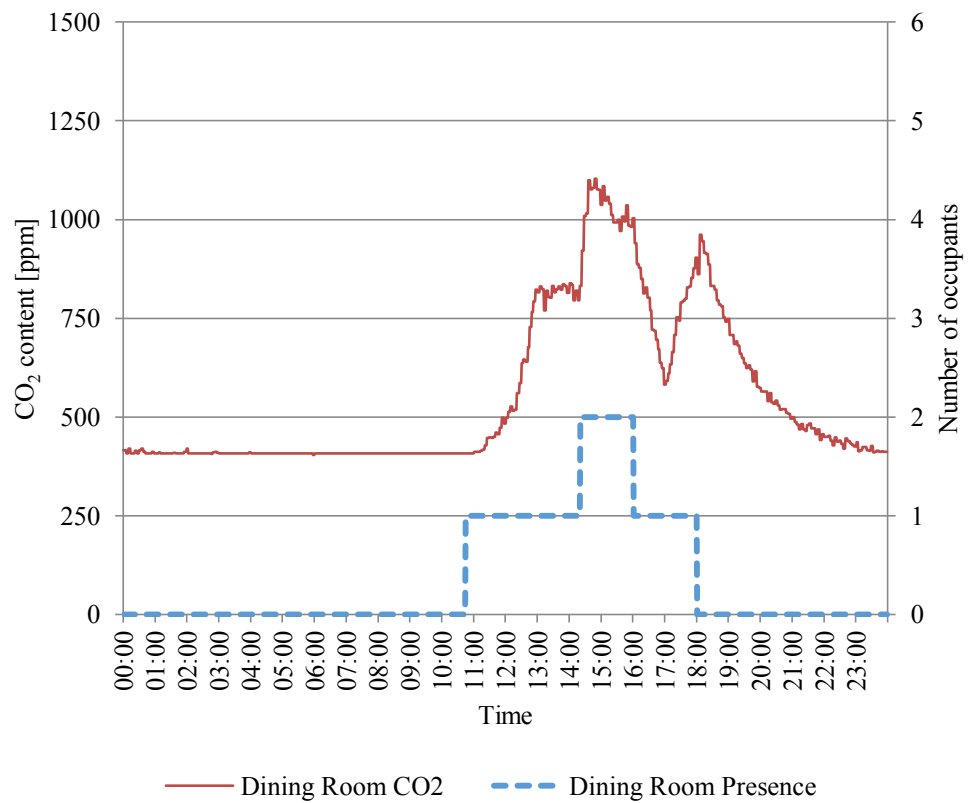

FIGURE 4-4: CO<sub>2</sub> CONTENT VERSUS HUMAN PRESENCE IN THE DINING ROOM

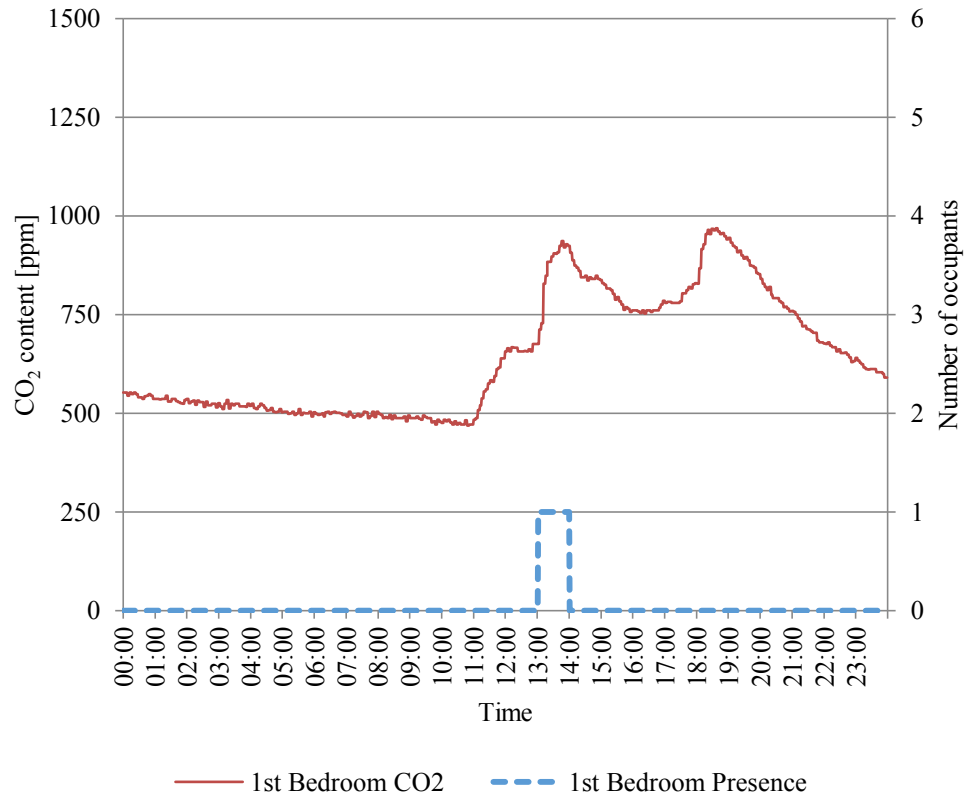

FIGURE 4-5: CO<sub>2</sub> CONTENT VERSUS HUMAN PRESENCE IN THE FIRST BEDROOM

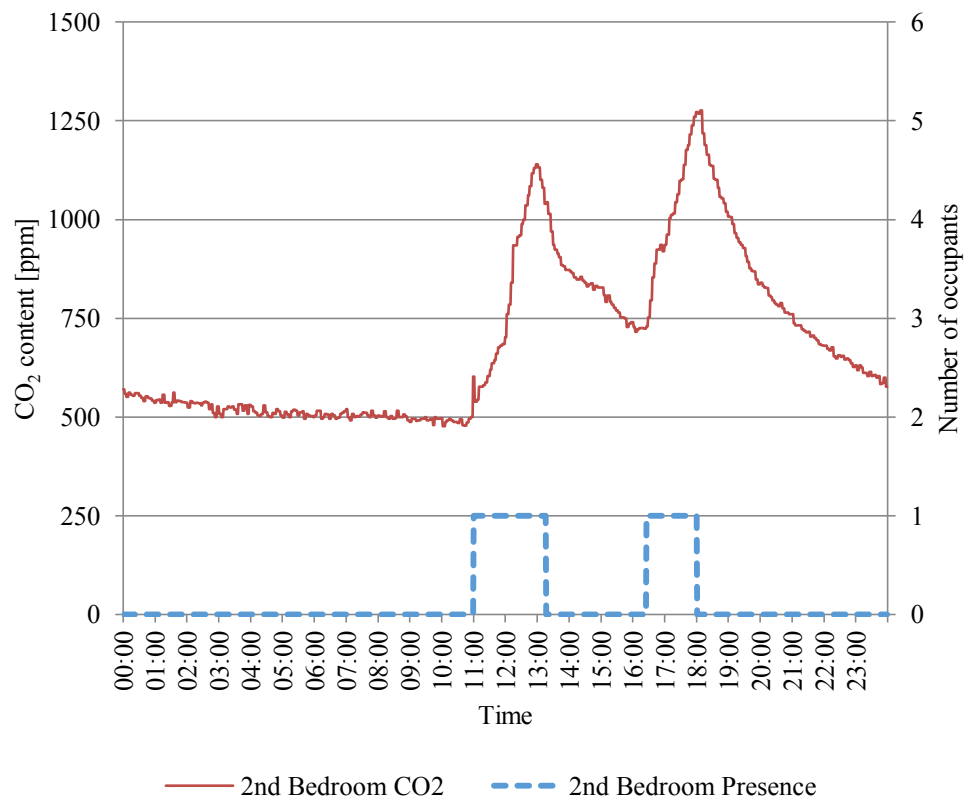

FIGURE 4-6: CO<sub>2</sub> CONTENT VERSUS HUMAN PRESENCE IN THE SECOND BEDROOM

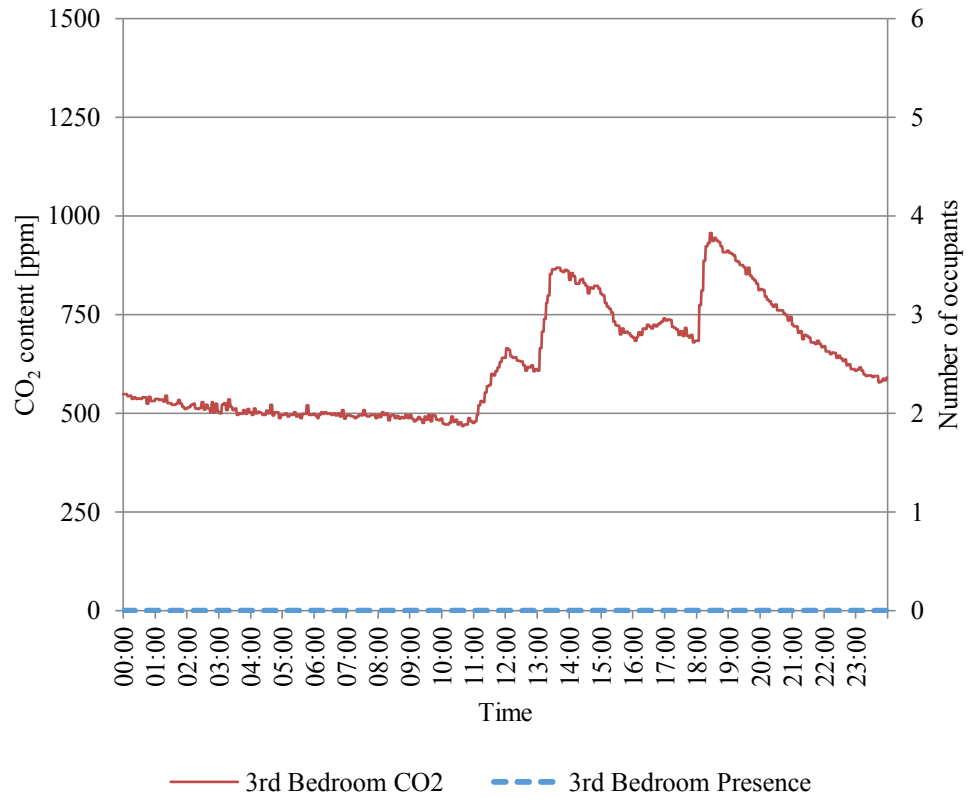

FIGURE 4-7: CO<sub>2</sub> CONTENT VERSUS HUMAN PRESENCE IN THE THIRD BEDROOM

### 4.3.2 PIR

On an aggregated level the PIR sensors correctly identified overall occupancy between 10:45 and 18:00, as represented in figure 4-8. However, individual room occupancy was slightly less well monitored.

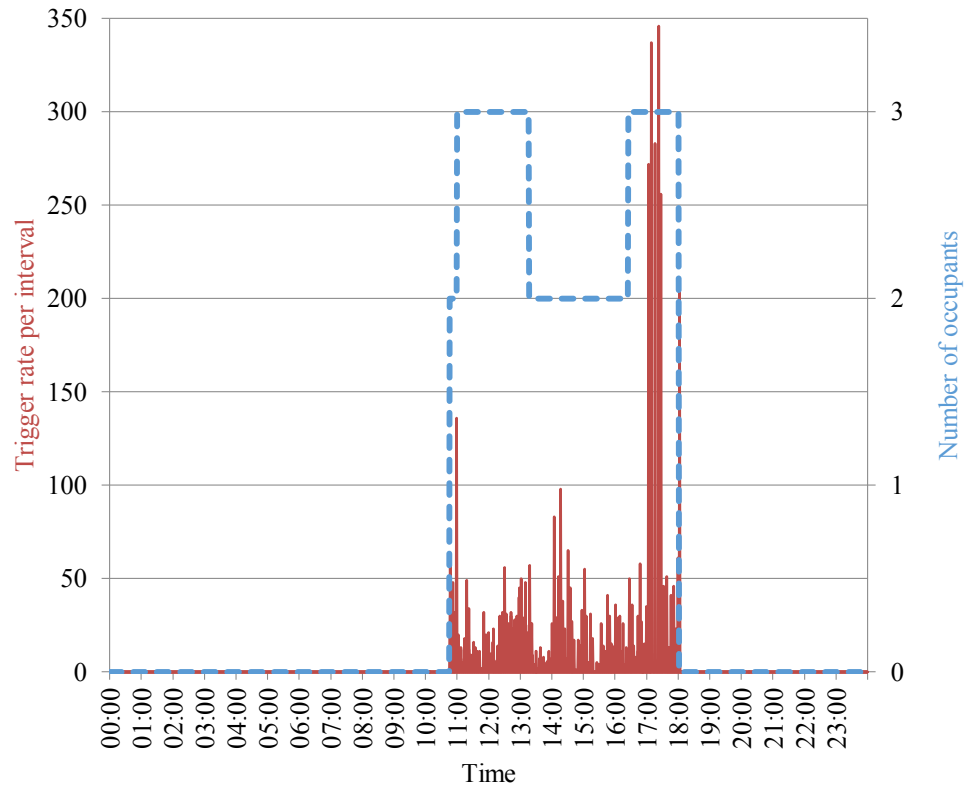

FIGURE 4-8: PIR MEASUREMENTS IN ALL ROOMS VERSUS OVERALL HUMAN PRESENCE

There were occasions of false negative output, i.e. the PIR sensors did not measure that someone was present. The longest false negative period was 29 minutes, which occurred in the living room between 11:38 and 12:07, as shown in figure 4-9. Reduced amount of movement by the participant could have been the cause.

False positive outputs on the other hand occurred comparatively rarely. Some activity measured by the kitchen PIR sensor, shown in figure 4-11, did relate to the kitchen bin being used. However, some measurements were triggered by the door being opened and closed, without anyone actually entering the room. This also applied to the first and third bedroom, as demonstrated in figure 4-12 and 4-14.

Furthermore, the kitchen PIR sensor's measurements in figure 4-11 were relatively high between 14:00 and 14:20 compared to other room's measurements, even compared to the spikes seen at the beginning and ending of occupancy periods, as for example in the second bedroom in figure 4-13. This could be related to the fact that the participant was standing, rather than sitting; and also that the kitchen was smaller than other occupied rooms, hence the visual



field was reduced which resulted in smaller stimuli triggering greater outputs.

In contrast, the dining room PIR sensor's measurements, shown in figure 4-10, did not increase with the number of participants present. Between 14:20 and 16:00 the values per submitted reading were similar to when the room was occupied by one participant. Though, the average might have been slightly, but insignificantly, raised.

The strongest PIR values were measured in the living room between 17:00 and 17:30, as presented in figure 4-9, when participant A was physically exercising.

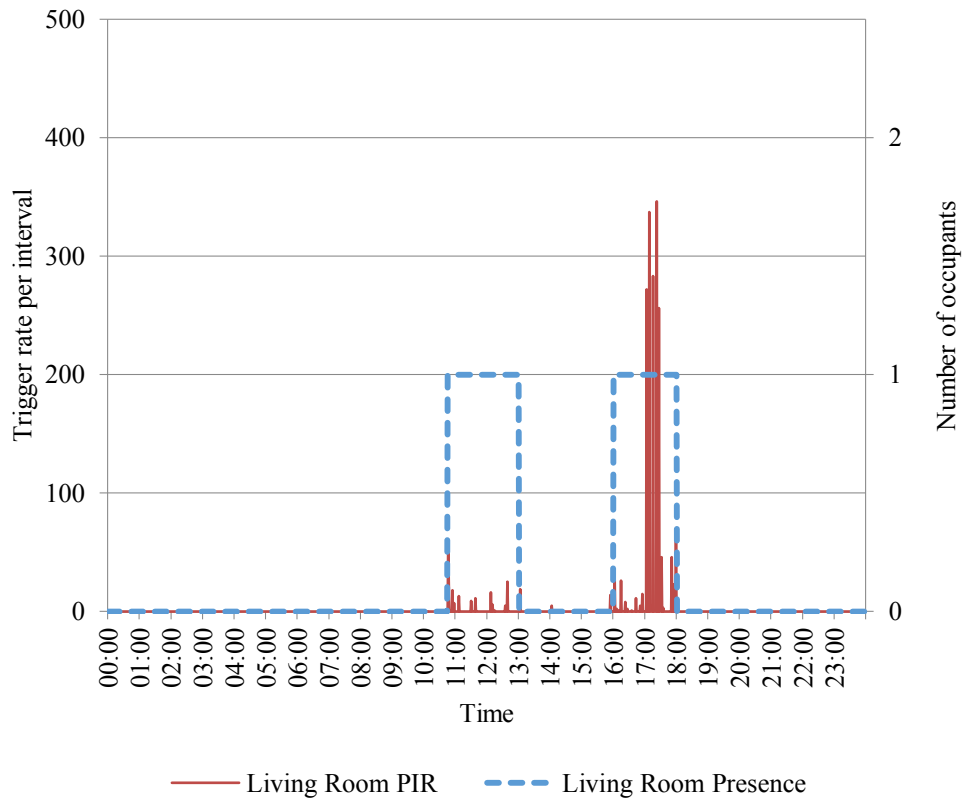

FIGURE 4-9: PIR VALUES VERSUS HUMAN PRESENCE IN THE LIVING ROOM

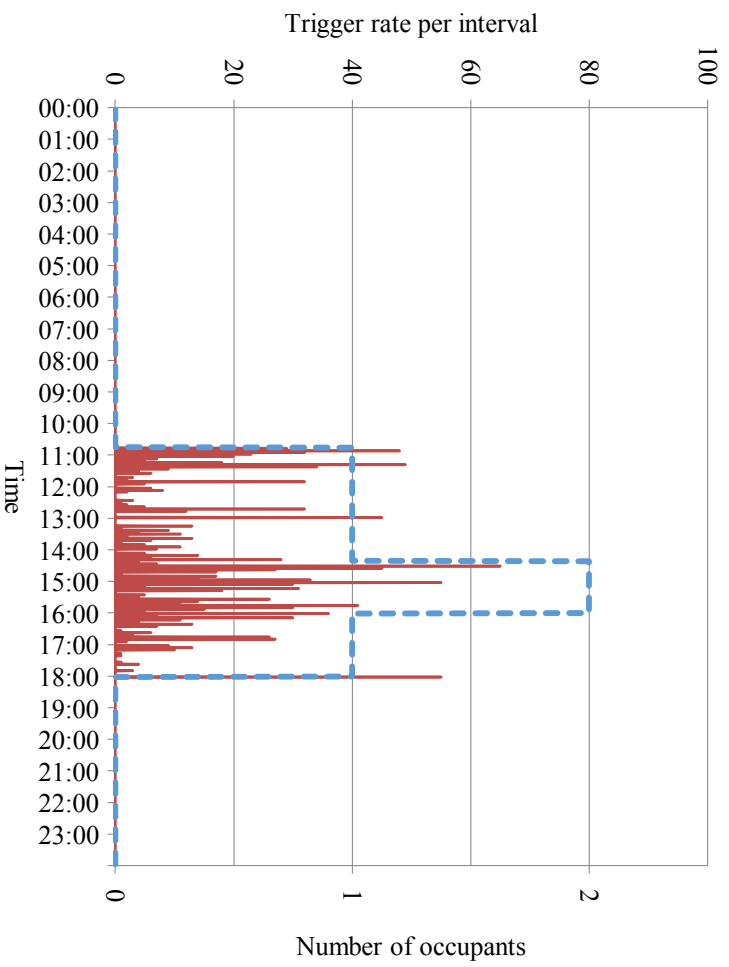

FIGURE 4-10: PIR VALUES VERSUS HUMAN PRESENCE IN THE DINING ROOM

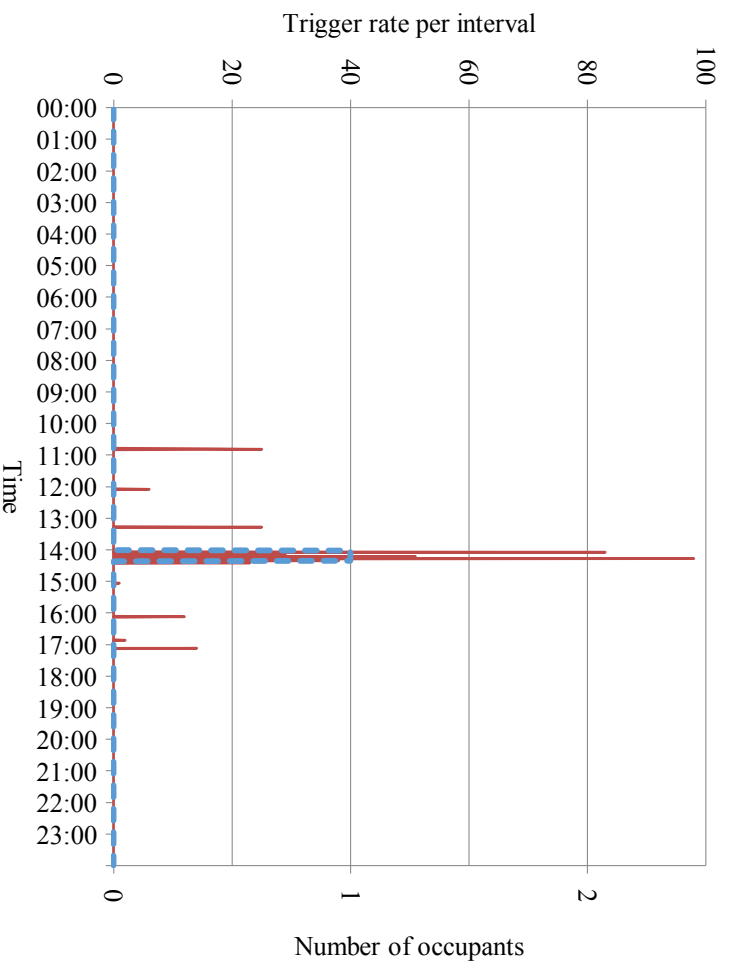

FIGURE 4-11: PIR VALUES VERSUS HUMAN PRESENCE IN THE KITCHEN

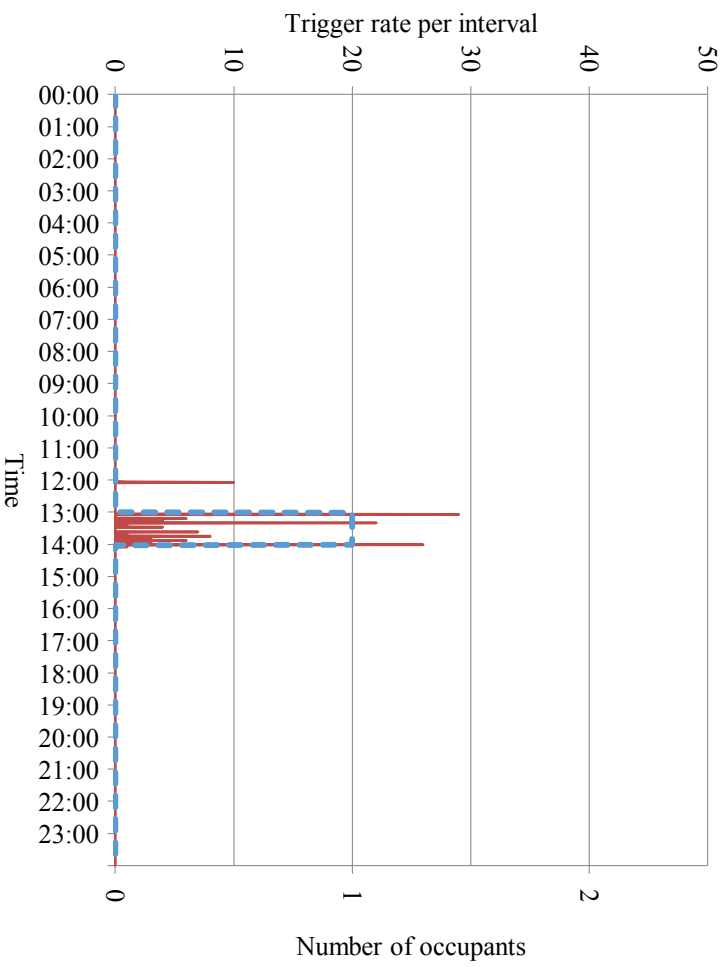

FIGURE 4-12: PIR VALUES VERSUS HUMAN PRESENCE IN THE FIRST BEDROOM

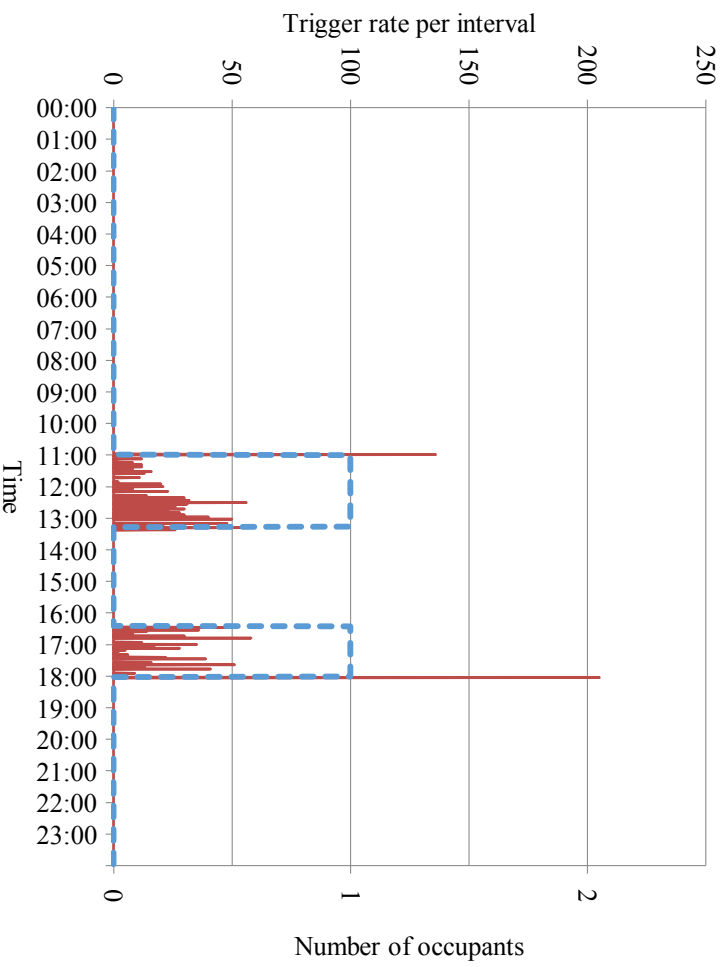

FIGURE 4-13: PIR VALUES VERSUS HUMAN PRESENCE IN THE SECOND BEDROOM

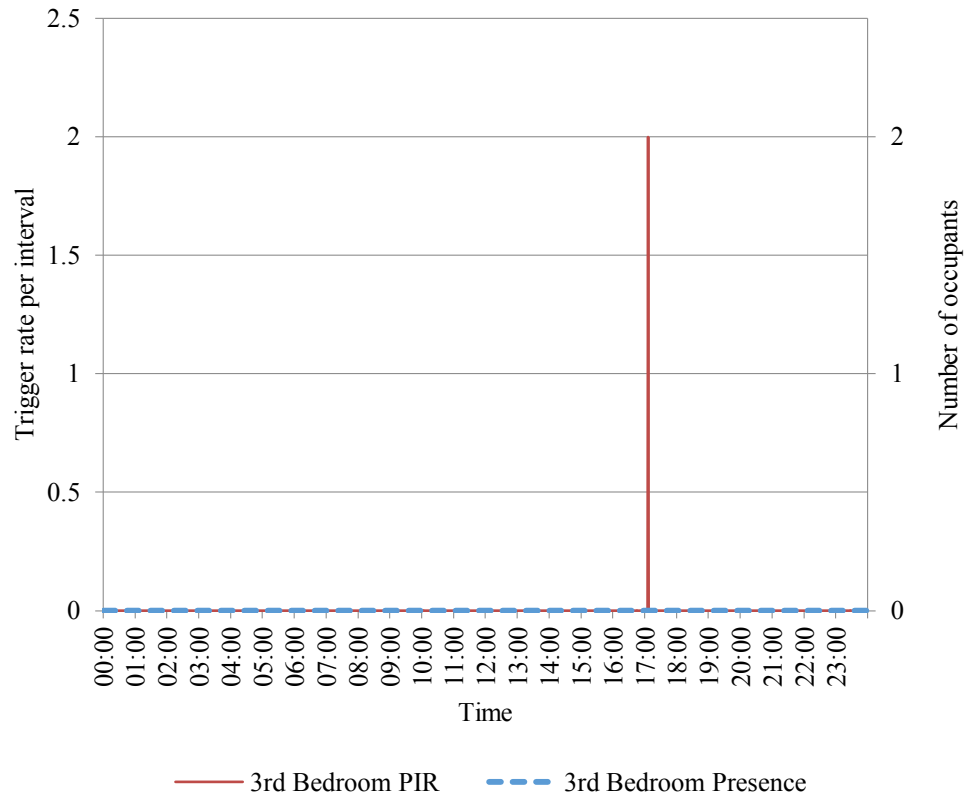

FIGURE 4-14: PIR VALUES VERSUS HUMAN PRESENCE IN THE THIRD BEDROOM

### 4.3.3 DFL

The signal strength for the occupied period from 10:45 to 18:00 had a clearly distinguishable pattern, as shown in figure 4-15. The fluctuations, mainly before, but also after that period, were related to the way Jennic modules calculate their LQI value. The difference between the module's maximum gain stages and those required to correctly receive a package are multiplied by six [91]. Hence, when the signal strength varied between two gain stages, the LQI changed by a step size of six. However, during the occupied period the variations in LQI values were often greater than six, less periodical and supported by other sensors changing simultaneously.

Also, the variations shown in figure 4-15 between 13:15 and 16:25, when only two participants were present, seemed less numerous than when all three participant were present.

Throughout the experiment, six sensors constantly kept the LQI value of 255, which is the maximum possible value of Jennic's modules [90]. Several other sensors also abruptly changed from a medium LQI value to this maximum. All those sensors provided correct readings of their measured data, such as temperature,

humidity, CO<sub>2</sub> or PIR. However, it is believed that this LQI value of 255 might represent missing module internal signal strength information as well as maximum signal strength.

The signal sniffer, employed during the study, showed that the signal connections were constantly rerouted. JenNet has a "route repair" function, which tries to establish new paths when the existing one is degrading [90]. This function made it very difficult to analyse the real-time communication paths and the associated spatial distribution.

Also, the signal sniffer demonstrated that a lot of network traffic was navigated through the same connection paths. Hence, the house internal area covered by radio signals was diminished, which might have reduced the variations seen in figure 4-15 and could lead to blind spots.

Furthermore, human presence seemed to be detectable outside of the house's envelope. Two sensors' LQI values, which clearly responded to the participants' presence throughout the experiment, varied before and after the participants were inside the house, as shown in figure 4-16. Potentially, the signal variation shown between 01:47 and 01:51 in figure 4-15, could have been related to another event, which took place outside the house.

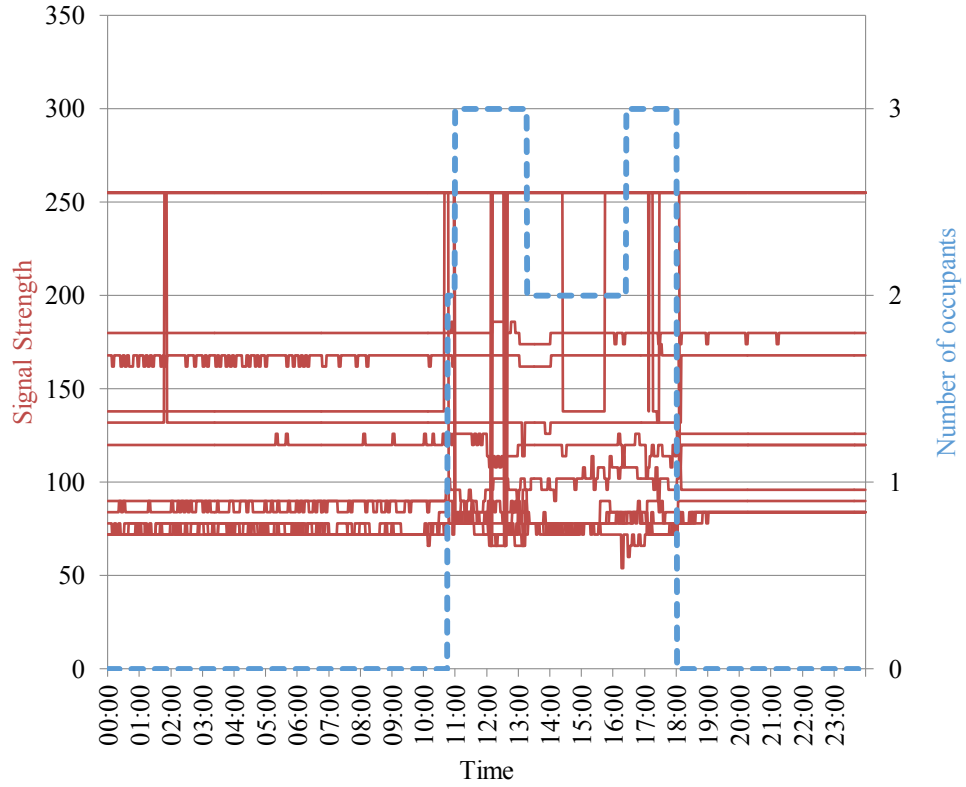

FIGURE 4-15: LQI MEASUREMENTS OF ALL THE JENNET EQUIPMENT VERSUS OVERALL HUMAN PRESENCE

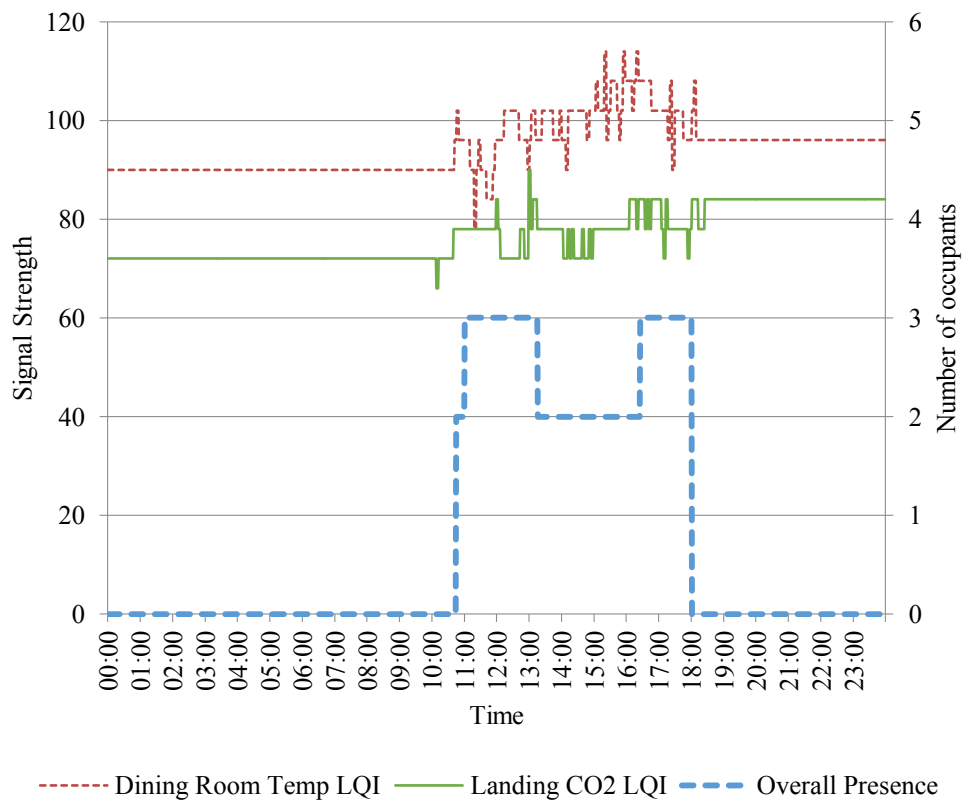

FIGURE 4-16: LQI MEASUREMENTS OF TWO PARTICULAR SENSORS VERSUS OVERALL HUMAN PRESENCE

## 4.4 DISCUSSION

### 4.4.1 CO<sub>2</sub>

The CO<sub>2</sub> sensors had a significant reaction time. This would impact the efficiency of a potential energy saving COAC system, especially as time sensitive control strategies could not be implemented. The study found an average delay of 15 minutes, which is coherent with Meyn et al's [92] estimation of 10 to 20 minutes.

Furthermore, CO<sub>2</sub> measurements were highly dependent on air circulation patterns. Ventilation rates and the rooms' layouts are of importance, as also highlighted by Emmerich and Persily [93]. This suggests that complex fluid dynamic analysis would need to be undertaken to interpret readings, which would be computationally demanding and energy consuming. Besides, manual ventilation, introduced by opening windows, using hairdryers or exercising, would be challenging to monitor.

Similarly, internal changes, such as closing doors, proved very disruptive to CO<sub>2</sub> patterns. Such interferences are not only difficult to monitor, but could also mask occupancy or occupant movement.

The study also demonstrated that the number of occupants cannot be deduced from CO<sub>2</sub> concentration levels, as falsely suggested by Leephakpreeda et al. [94] and many others [95-97]. Physical exercise, which increases a human's metabolic rate and thus their CO<sub>2</sub> emissions, seemed to have a greater impact than multiple occupancy. Hence, metabolic rates and activity levels would need to be monitored separately, which would defeat the unobtrusive nature of this domestic localisation technology.

### 4.4.2 PIR

False negative as well as false positive measurements occurred during the experiment. Participants remaining still and moving objects were the main causes respectively. If acted upon, this deficiency in accuracy could adversely impact energy saving COAC systems, for example by reducing user's trust.

Furthermore, the study has shown that the visual area of a given PIR sensor as well as the occupant's distance in relation to it, were significant factors. Akhlaghinia et al. [98] demonstrated that PIR sensors can also have difficulties to cover the desired visual area or

be mistakenly triggered by events in rooms they were not associated with.

The misconception that the trigger rate of PIR sensors is proportional to the number of occupants present was disproven. Multiple occupants in one room had a comparatively limited impact on PIR values in relation to the physical activity of a single occupant.

### 4.4.3 LQI

The study found signs for a relation between occupancy and signal strength. It also highlighted the importance of the spatial propagation of signals, as this affected the coverage of the monitored area. Besides, it was shown that DfL has the potential to measure multiple occupancy.

However, the proprietary nature of the radio equipment used was a major impediment. Signal paths could not be set or changed and signal strength was calculated in an ill-defined manner, which impacted the data's precision and its analysis.

Additionally, it was demonstrated that DfL technology can monitor events occurring behind walls. This would be beneficial in the context of energy saving COAC systems, as it facilitates coverage of a house's internal area of interest. Furthermore, it could accommodate for automation of garden related tasks and control strategies, which require the information whether an occupant has left a house or is about to enter it. On the other hand, this feature requires great care as it could infringe the privacy of neighbouring people.

The fact that an automation control system's existing wireless infrastructure can be used for DfL is a substantial advantage. This reduces hardware cost and visual impact, as no extra sensors would be required.

## 4.5 CONCLUSION

All three unobtrusive technologies, CO<sub>2</sub>, PIR and DfL, were able to detect overall occupancy to some extent. PIR sensors also measured room level occupancy relatively accurately.



However, both, CO<sub>2</sub> and PIR sensors, had significant intrinsic weaknesses, which suggest that they are not able to localise or track occupants. CO<sub>2</sub> sensors demonstrated a very slow response time and were highly vulnerable to air circulation patterns. Whereas PIR sensors were prone to false outputs and were limited in their visual area. Also, both were prone to an increased human activity level.

DfL technology, unlike CO<sub>2</sub> and PIR, seemed to be able to detect multiple occupancy. It also possess significant advantages in the context of domestic energy saving COAC systems, as it is based on existing wireless infrastructure, which reduces its cost and visual impact. Its ability to monitor events behind walls also suggests that it is able to broadly cover any area of interest.

Hence, DfL has greater potential with regards to a COAC system application than CO<sub>2</sub> and PIR based technologies. Further research should be undertaken to establish its full capabilities, especially with regards to the extent to which occupants can be localised and how multiple occupants can be tracked. However, proprietary equipment should be avoided as it hinders experimental research setups.

### 4.6 CHAPTER CONCLUSION

Three occupant detection technologies appropriate for the domestic environment were identified and assessed with regards to criteria set out by COAC requirements. It was experimentally demonstrated that CO<sub>2</sub> and PIR based occupant detection technologies have significant drawbacks. In contrast, the emerging DfL technology, which is based on wireless signal strength, showed significant potential and was therefore chosen to be studied in more detail. However, further investigations into DfL's capabilities are required. Hence, chapter 5 reviewed existing literature, especially in the context of applying DfL to COAC.

## 5 DEVICE-FREE LOCALISATION (DFL)

### 5.1 INTRODUCTION

DfL was identified in chapter 4 as an occupant detection technology suited to the domestic environment. It was also established that it has greater potential than a variety of other technologies, including CO<sub>2</sub> and PIR based methods, in the context of energy saving COAC systems. However, its full abilities are not sufficiently explored yet. Hence, an analysis of DfL's underlying physical principles was described and the current research state in this field was discussed. Also, potential health and security impacts and perceptions in the context of the domestic application of DfL were highlighted.

### 5.2 PHYSICAL PRINCIPLES

The propagation of electromagnetic radiation, which includes radio waves, is highly complex and is determined by the wavelength as well as the electromagnetic characteristics of the medium through which it travels. Friis' [99] transmission equation describes a signal's power, as seen by a receiver. It is commonly presented in the form shown in equation 5-1.

$$P_r = P_t + G_t + G_r + 20 * n * \log_{10}\left(\frac{\lambda}{4\pi d}\right)$$

EQUATION 5-1: TRANSMISSION EQUATION DERIVED FROM FRIIS' [99]

- Pr: received power [dBm]
- Pt: transmitted power [dBm]
- Gr: receiving antenna's gain [dB]
- Gt: transmitting antenna's gain [dB]
- d: distance between both antennas [m]
- λ: wavelength [m]
- n: path loss exponent, dimensionless

Equation 5-1 assumes that the signal is broadcast uniformly in all directions and so in line with the inverse square law the intensity decreases with distance. However, Lymberopoulos et al. [100] experimentally demonstrated that RSS is highly impacted by

antenna design and that it cannot be related to the inverse square law path loss model in indoor environments due to multipath effects and link asymmetries. They also showed that radios have intrinsic variations in transmission and receiving patterns.

The path loss exponent  $n$  in equation 5-1, which is environment dependent and needs to be experimentally determined, accounts for the mentioned multipath effects. They are caused by four phenomena: reflection, refraction, diffraction and diffusion. The different signal fractions associated with the different transmission paths can, depending on their phase angle, be additive or subtractive thus increasing or decreasing the RSS respectively. Hence, as Stein [101] established, indoors signal strength does not necessarily decrease linearly with distance or number of floor levels.

The interaction of electromagnetic radiation with material is characterised by the material's relative permittivity. Shamir [102] pointed out that water has a comparatively high relative permittivity at a 2.4 GHz frequency, which makes it more reflective and absorbent in comparison to other building materials. Wilson [103], who experimentally measured signal reflections, transmissions and absorptions in 20 building materials, confirmed these findings by comparing dry and wet measurements.

It is noteworthy that the human body is mainly composed of water [104]. The presence of humans is therefore likely to affect radio signals, particularly those at 2.4 GHz. DfL is based on this concept. It analyses RSS information to determine human interference. Establishing the environment's impact, or any other variable in equation 5-1, is arguably not even necessary for this purpose.

DfL can be implemented using various different radio technologies. Many studies [105-109] used IEEE 802.11 standard based radios, also known as Wi-Fi, which operate at 2.4 GHz. Radios using lower frequencies than 2.4 GHz, were also demonstrated to be able to detect human presence [110-112]. However, the radios used in the application of automation control are predominantly based on the IEEE 802.15.4 standard, as mentioned in section 3.3.2. Therefore, the following literature review, which analysed the progress in DfL research, focused on studies employing these particular types of radio.

### 5.3 LITERATURE REVIEW

DfL is a very recent technology. Many other terms have been used to describe systems with similar mechanisms. For example, Wilson and Patwari [113] called it radio tomographic imaging when they positioned 28 TelosB radios in a square of approximately 41 m<sup>2</sup> and let every radio submit packets to all others. They analysed each link's mean RSS assuming that signals were being "shadowed" if a person stood in the Line Of Sight (LOS). They were also able to localise two people Wilson et al. [114]. However, this method was very energy intensive, especially as many radios as well as communication links were required. Hence, Kanso and Rabbat [115] applied sampling techniques to Wilson and Patwari's data to reduce the amount of required measurements and communication links, thus making it more energy efficient. They also suggested that deterministic communication between nodes would be better than randomised communication in terms of accuracy. However, their simulation results did not show significant differences between both communication methods. Furthermore, both studies interpreted their RSS data by directly linking it to graphical pixels, which influenced and most likely distorted the accuracy of the DfL capabilities of their respective findings.

Kaltiokallio et al. [116] suggested that the network structure should be employed to deduce people's locations. They used four radios, which partially shared the same LOS, and demonstrated that the RSS of one, two or three of them would drop simultaneously depending on the person's position. However, this implies that time synchronisation for all nodes would be required, which is not intrinsic to wireless networks.

A similar method, which eliminated the need for time synchronisation was presented by Woyach et al. [117]. They determined the velocity of a participant by letting them walk and run through the LOS of two pairs of radio connections, which submitted their RSS readings to a central node for processing. However, their system can only be applied to monitor people in constant motion, which is not necessarily the case in domestic environments.

Lee et al. [118] assessed the impact of moving and non-moving humans on the LOS in five different environments. Their results

showed narrow RSS distribution for the latter and widespread distribution for the former. Based on those findings they built a threshold algorithm, which analysed signal fluctuation, and were able to identify human movement with some minor false positive outputs.

Wilson and Patwari [119] also investigated the variance of RSS in relation to human movement, which they called variance-based radio tomographic imaging. They deployed 34 TelosB radios around external walls of an area of approximately 72.5 m<sup>2</sup> and tracked a moving person inside, using a Kalman filter. The average error was one meter for a person moving in circles and approximately half that for a person moving on the spot.

Chen et al. [120] experimentally compared Wilson and Patwari's Kalman filter to a Sequential Monte Carlo filter, using an outdoor area of 7 m by 7 m and 24 nodes. They found that the Sequential Monte Carlo filter was superior and highlighted that both methods' performance declined with static obstructions, such as trees.

Viani et al. [121] also tracked a person in an outdoor environment by employing a support vector machine, which was trained offline. The radio to surface ratio was similar to the previously mentioned studies with six nodes for a 15 m<sup>2</sup> area. Unfortunately, Viani et al. did not quantify their system's performance.

A method combining mean and variance based measurements was suggested by Yang et al. [122]. They differentiated static and moving people by using a statistical t-test methods with a clustering approach, combining the moving mean and moving variance of RSS inputs. They highlighted that detection precision could be improved by combining several radio links, but noticed that it needed to be calibrated as the inclusion of too many RSS inputs could lead to lower detection rates.

Hussain et al. [123], who developed an intruder alarm based on the mean and the standard deviation of RSS data coupled to a moving window algorithm. They pointed out that the window size defined the amount of false negative and false positive intruder alarms, and that therefore only a compromise could be struck. Yao et al. [124] also highlighted that the width of a moving window is linked to the computational power required to analyse it. Hence, larger windows could introduce significant time delays.

Furthermore, Nakatsuka et al. [125] experimentally demonstrated that RSS variance was proportional to the number of people present and that mean RSS was inversely proportional to it. They suggested that variance was more accurate for crowd estimation purposes than mean RSS or a combination of both.

However, Yao et al. [124] suggested that the variance in RSS decreased with the distance of the moving person in relation to the radios.

Patwari and Wilson [126] evaluated this hypothesis by analysing the effects of reflection and diffusion independently and in relation to the radios' relative height. They found that if radios were relatively close to a surface, a person standing either near the transmitter (TX) or near the receiver (RX) would have the greatest impact on RSS due to signal reflection. Otherwise, if the radios were relatively far away from a reflective surface, standing in the LOS would impact the RSS more.

Vance et al. [127] undertook a series of experiments, which confirmed that the LOS is particularly sensitive to human presence and that their proximity to either radios yield unique patterns. Furthermore, they employed threshold and neural network algorithms to analyse data provided from four radios. However, their conclusion of 84 percent accuracy to detect a person within 1.5 m was unsatisfactory, as the overall area was apparently 3 m<sup>2</sup>.

Wang et al. [128] used a shielding device to limit the antenna's multipath propagation created by indoor environments. However, they noted that this reduced the angle of vision to 45° and introduced a new and more powerful multipath component within the shielding device itself, and hence declared it useless.

In an outdoor environment Uchida et al. [129] tested different sensor positions, which showed that RSS sensitivity to objects varied with sensor height and sensor distance.

Christmann et al. [130] and Lymberopoulos et al. [100], who did not study DfL in particular, found that the signal properties of RSS do not change with input power but decrease proportionately with it.

Furthermore, Wang et al. [128] and Hussain et al. [129] demonstrated that sensors should not be too far apart, as human

interference would have a smaller impact and could lead to loss of connection altogether; a radio distance of 2.5 m for example produced a variation in RSS of only 3 dBm.

Conclusively, some questions regarding possible network layouts have been answered using experimental demonstrations. However, none of the studies was performed with regards to the constraints imposed by domestic COAC systems. For example, the radios are likely to be close to walls, as they are integrated into sensors and actuators.

Also, network density has not comprehensively been assessed. Wilson and Patwari [113] merely simulated node density in relation to square, front-back and random sensor deployment in relation to their radio tomography imaging method.

Furthermore, the majority of studies, which were reviewed, combined their assessment of RSS directly with network layouts or interpretation algorithms. Thus, the intrinsic characteristics of DfL itself remain largely unclear.

Besides, they all employed either continuous transmissions or packet transmissions with resolutions between 20 and 100 ms. However, these are not applicable in the context of an energy saving automation control system, as the energy used by each transmitted packet would be counterproductive to the overall aim. Also, battery life of automation equipment would need to be considered.

Additionally, very few studies examined whether the detection of several people was possible. Yet, as section 3.4.2 outlined, this would be required of any occupant detection technology used for the implementation of COAC.

Therefore, a comprehensive analysis of DfL capabilities in the context of COAC systems is necessary, which was undertaken in chapters 7 to 9. However, first, due to DfL being an emerging technology, chapter 6 conducted a feasibility study which sought to confirm the current research state of DfL.

## 5.4 HEALTH AND SECURITY

Another aspect, which has entirely been dismissed by the DfL research community so far, is the human's perception of this system. Electromagnetic radiation can be a health hazard if applied in disproportionate measures to the human body. Microwave ovens, for example, use the same 2.4 GHz frequency band, though at much higher power levels and in a contained area, to heat objects. However, other electromagnetic equipment, such as mobile phones and Wi-Fi routers are omnipresent. The recommendations for uncontrolled whole-body exposure at 2.4 GHz are to keep power levels under 0.08 W/kg [131,132]. Yet, there is no enforcement of those guidelines in the domestic environment and no oversight of the additive effects of different electromagnetic equipment. Hence, some people are very concerned with the influence of electromagnetic fields and have reported electromagnetic hypersensitivity, which is associated with medical symptoms [133]. Therefore, chapter 10 investigated the perceived health concerns associated with domestic DfL application using the more known Wi-Fi technology as reference.

The security perception of gathered information also requires consideration. As mentioned in chapter 3, smart meters, which submit energy usage data, could leave households exposed to crimes, if information about the house's occupancy can be deduced. With DfL being based on radio signals, it would be reasonable to assume that users might feel even more vulnerable to hostile attacks or interference with neighbouring networks. However, the proposed DfL system would be integrated into existing wireless networks and thus use their defensive structures, some of which are outlined by Radosavac [134]. Additional measures, such as switching between separate radio channels [129] or using distributed decentralised processing [115,116] could also be implemented were deemed necessary. However, for the adoption of COAC systems which use DfL not only the actual security threat is important, but the perceived one, too. Hence, chapter 10 investigated any potential security concerns regarding DfL using a questionnaire study.



## 5.5 CHAPTER CONCLUSION

The physical principles underpinning the concept of DfL, particularly for human detection in domestic environments, were highlighted. A literature review, which focused on studies employing IEEE 802.15.4 standard based equipment, established that DfL is a comparatively recent technology. Hence, chapter 6 conducted a series of experiments to confirm its feasibility and support some of the discussed findings.

Also, the literature review established that many studies combined DfL data directly with their interpretation methods, which effectively obscured their findings regarding DfL's capabilities. Additionally, no evidence of research targeted at the integration of DfL into an automation control system's existing wireless infrastructure was found. Chapters 7 to 9 therefore investigated this relation further by employing a number of experiments, which were examined with simple statistical tools.

The potential health and security concerns of users were also outlined and it was argued that user perception of DfL plays a crucial role in its adoption. Hence, as part of chapter 10, the public acceptance level of DfL technology was researched using a questionnaire.

## **6 DfL – FEASIBILITY STUDY**

### **6.1 INTRODUCTION**

DfL is still in its early stages and there are a lot of open questions, especially with regards to optimal implementation in a COAC context, as discussed in chapter 5. However, before they can be assessed in detail the novelty and sparseness of DfL research requires a feasibility study. Hence, this chapter investigated whether reported findings are reproducible and identified radio settings, which might favour DfL. Therefore, a range of frequencies to which DfL could be applied was explored. Also, in the context of human presence, the relation between RSS and signal input power as well as its relation to bandwidth has been examined. Finally, the impact of a human's position with regards to a radio communication link was investigated.

### **6.2 EQUIPMENT**

The equipment, which was used for the tests described in this chapter, consisted of a CC1101 development kit [135]. A particular advantage was its ability to visualise continuous signal reception and thus provide instantaneous feedback about signal reactions. The equipment could also be operated in packet transmission mode.

The development kit consisted of two CC1101 radios with monopole antennas which were mounted on evaluation boards. Furthermore, a software was supplied, which enabled the ability to change the radios' settings and provided feedback on their RSS. The evaluation boards needed to be connected via USB cables to the software operating computer for this purpose.

The radios were labelled as operating in the 868 to 915 MHz range. However, the supplied software allowed them to be operated in the 300 to 348 MHz, the 387 to 464 MHz and the 779 to 928 MHz frequency bands.

### 6.3 FREQUENCY RANGE

In section 5.2 it was briefly mentioned that DfL can be implemented using lower frequencies than 2.4 GHz. This also applies to the IEEE 802.15.4 standard which is ideal for automation control, as mentioned in section 3.3.2. In addition to the licence-free frequency bands mentioned there, the IEEE 802.15.4 standard is designed for 314 to 316, 430 to 434 and 779 to 787 MHz operation in China and 950 to 956 MHz operation in Japan [70]. Hence, the following experiment explored and established the implications for DfL at a variety of frequencies below 2.4 GHz.

#### 6.3.1 METHODOLOGY

The two CC1101 radios were placed 1 m apart at a 0.75 m height and their antennas faced each other. One was setup as TX and the other as RX. The software had a “frequency swiping” option for the TX, but no equivalent for the RX. Hence, the frequencies needed to be set manually. It was therefore chosen to test the three frequency ranges mentioned in section 6.2 at their permitted extremities, i.e. 300 MHz, 348 MHz, 387 MHz, 464 MHz, 779 MHz and 928 MHz. The transmission power was set to 0 dBm and the transmission method to continuous.

Initially, the RSS was observed for an empty environment. Afterwards, a person moved around the radios and actively obstructed the LOS. The RSS, which was displayed on the screen, was simultaneously analysed.

#### 6.3.2 RESULTS

At 300 MHz, the RSS changed very abruptly without anyone present and had a very low mean RSS; almost to the point of no clear reception. However, with a person in the LOS or other areas near the radios, the RSS actually increased, although it stayed very volatile.

At 348 MHz, the baseline RSS was very strong with approximately -20 dBm. The signal was smooth and dropped between -10 dB and -20 dB with a person present in the LOS.

At 387 MHz, the baseline signal reception was similar in strength to that of 348 MHz. However, the responsiveness of the signal to human presence decreased to between -5 dB and -10 dB.

At 464 MHz, the RSS measured without human presence was approximately -40 dBm, i.e. lower than the previous two frequencies. In contrast, the signal drops caused by human presence were far greater with some beyond -20 dB.

At 779 MHz, the baseline reception without a person in the radios' proximity was -35 dBm. The drops in RSS with human presence were similar to those seen for 464 MHz, i.e. exceeding -20 dB.

At 928 MHz, the baseline signal reception was -25 dBm, but the drops with human presence were only -10 dB. Also, the signal seemed overall less responsive.

### 6.3.3 DISCUSSION

The signal characteristics varied significantly between the chosen six frequencies, even with comparatively small step sizes between some of them. However, the greatest difference was noticeable between 300 MHz and all the other frequencies, as it was the only one that had erratically changing RSS, which clearly increased with human presence. This could suggest that the antennas supplied were not appropriate for operating at this extremity.

Also, between the other five frequencies, the responsiveness of the signal varied. Some frequencies appeared to produce a smoother RSS response than others, which simultaneously gave the impression of a slower response times. It is likely that the test environment interacted differently with each of the frequencies, by for example producing more or less multipath. This could explain the difference in baselines RSS without human presence.

In summary, the experiment has shown that all tested frequencies responded to human presence. It thus supported Zhang and Ni's [111] as well as Lieckfeldt et al.'s [112] findings, who studied DfL at 868 and 870 MHz, and presented further potential frequencies for its implementation, for example in the scope of COAC applications in China. However, as mentioned in section 3.3.2, only the 868 to 929 MHz range would be of interest for licence-free applications.

#### 6.3.4 CONCLUSION

It was demonstrated that frequencies ranging from 300 to 928 MHz responded to human presence, although to different extents. Due to the signal behaviour at the lowest extremity and due to the licence nature of certain frequency ranges, it is suggested that the following experiments focus on the 868 to 928 MHz range.

### 6.4 HUMAN MOVEMENT AND RADIO SETTINGS

The previous experiment, in section 6.3, suggested that the 868 to 928 MHz range should be investigated further as operating within it does not require a licence. The experiment also showed that several frequencies reacted to human presence. Hence, bandwidth settings and their relation to human presence should be assessed.

Furthermore, studies reviewed in section 5.3, indicated that the relation between input power and RSS response are proportional. However, these studies were not conducted in the context of human presence. Therefore, an experiment was designed to examine frequency, bandwidth and power settings. All three variables were linked by using a common test environment and methodology.

#### 6.4.1 METHODOLOGY

The two CC1101 radios, one setup as TX and one as RX, were positioned on the edges of two opposing tables at a 1.5 m distance from each other, see figure 6-1. The room's walls were approximately 0.8 m behind both of them. The radios were operated in continuous transmission and reception mode.

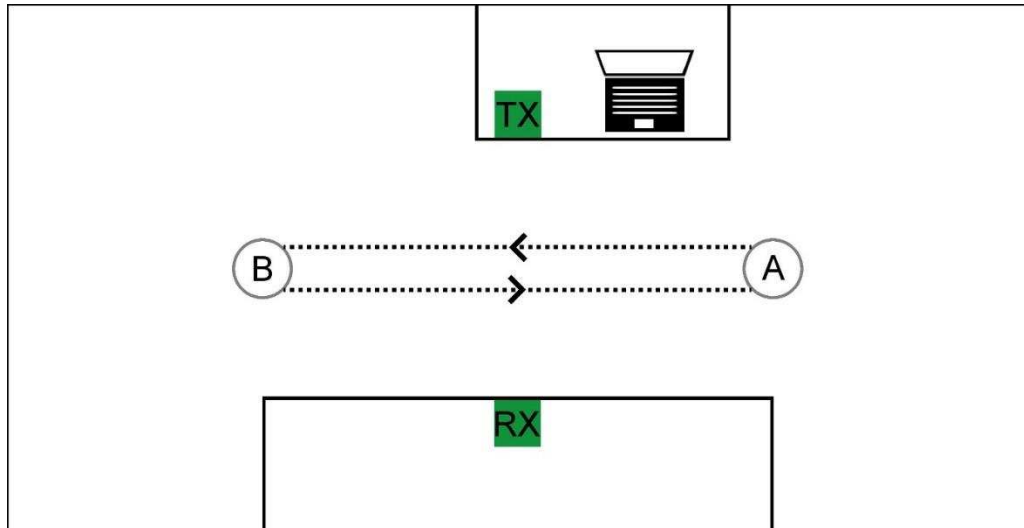

FIGURE 6-1: PERSON'S TRAJECTORY IN RELATION TO TX AND RX

Different frequency, power and bandwidth settings were tested by changing the parameters sequentially for both radios. The frequency channels 0, 50, 100 and 255, corresponding to 868, 878, 888 and 919 MHz respectively, were examined as well as the power settings of 12, 0 and -30 dBm and the bandwidth settings of 58, 406.25 and 812.5 kHz. The default setting, which was shared by all three experiments, was channel 0, 0 dBm and 58 kHz bandwidth.

For each configuration the RSS was initially measured without an applied signal. Then, a signal was applied and a participant walked from position A to position B and back, as shown in figure 6-1. Screenshots of the RSS were made, as the data could not be recorded in a different format.

## 6.4.2 RESULTS

### 6.4.2.1 FREQUENCY SETTING

The RSS levels, which were recorded without an applied input signal, did not indicate any presence of noise for channels 0, 50 and 255, as shown in figure 6-2. However, channel 100 seemed to record noise, as depicted in figure 6-3.

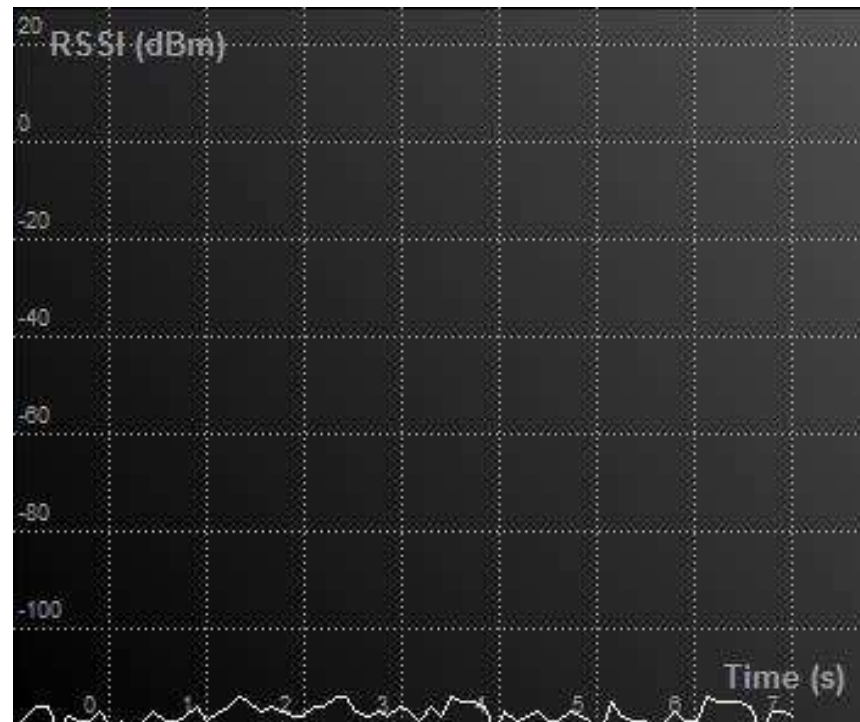

FIGURE 6-2: CHANNELS 0, 50 AND 255 WITHOUT AN INPUT SIGNAL

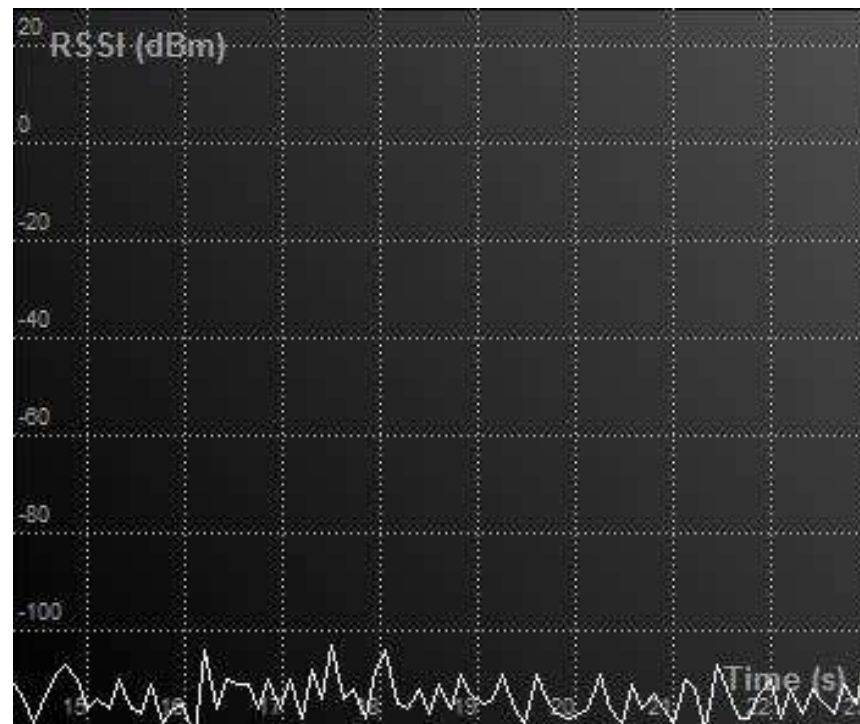

FIGURE 6-3: CHANNEL 100 WITHOUT AN INPUT SIGNAL

The RSS measured with an applied 0 dBm signal and whilst a person walked along the trajectory depicted in figure 6-1, is represented in figures 6-4, 6-5, 6-6 and 6-7 for channels 0, 50, 100 and 255 respectively.



FIGURE 6-4: CHANNEL 0 WITH A 0 DBM SIGNAL AND A PERSON CROSSING THE LOS TWICE



FIGURE 6-5: CHANNEL 50 WITH A 0 DBM SIGNAL AND A PERSON CROSSING THE LOS TWICE





FIGURE 6-6: CHANNEL 100 WITH A 0 dBm SIGNAL AND A PERSON CROSSING THE LOS TWICE



FIGURE 6-7: CHANNEL 255 WITH A 0 dBm SIGNAL AND A PERSON CROSSING THE LOS TWICE

#### 6.4.2.2 POWER SETTING

The RSS without and with applied signals of 12, 0 and -30 dBm were measured, as shown in figures 6-8, 6-9 and 6-10 respectively.

Table 6-1 represents the difference between the transmitted and received power levels.



FIGURE 6-8: CHANNEL 0 WITHOUT AND WITH A 12 DBM INPUT SIGNAL

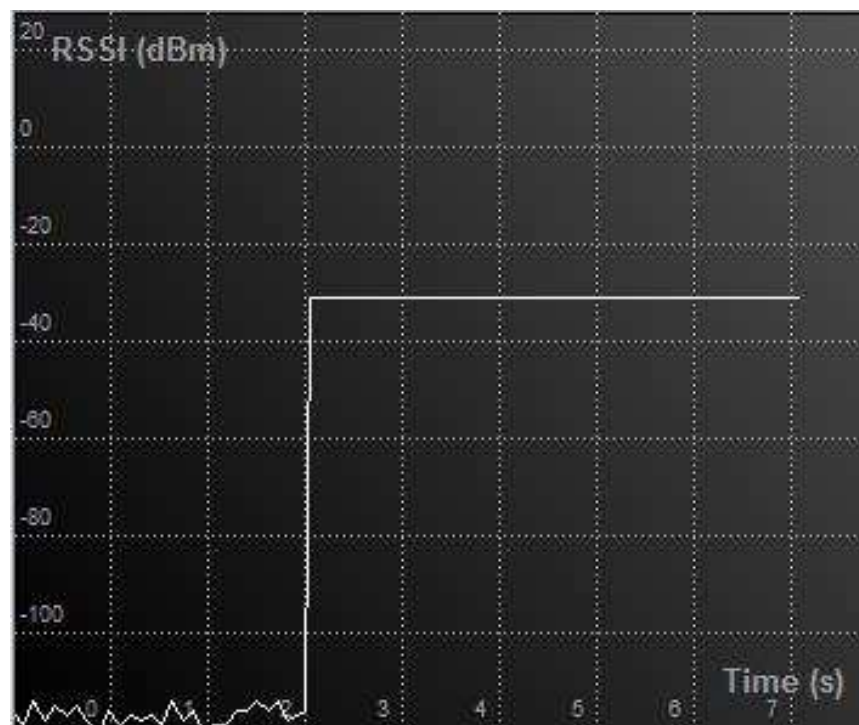

FIGURE 6-9: CHANNEL 0 WITHOUT AND WITH A 0 DBM INPUT SIGNAL



FIGURE 6-10: CHANNEL 0 WITHOUT AND WITH A -30 dBm INPUT SIGNAL

TX's power [dBm]	RX's power [dBm]	Difference [dB]
12	-24	36
0	-31	31
-30	-59	29

TABLE 6-1: DIFFERENCE BETWEEN TRANSMITTED AND RECEIVED POWER LEVELS

The RSS levels recorded with the applied input signals of 12, 0 and -30 dBm and whilst a person walked along the stated trajectory are represented in figures 6-11, 6-12 and 6-13 respectively.

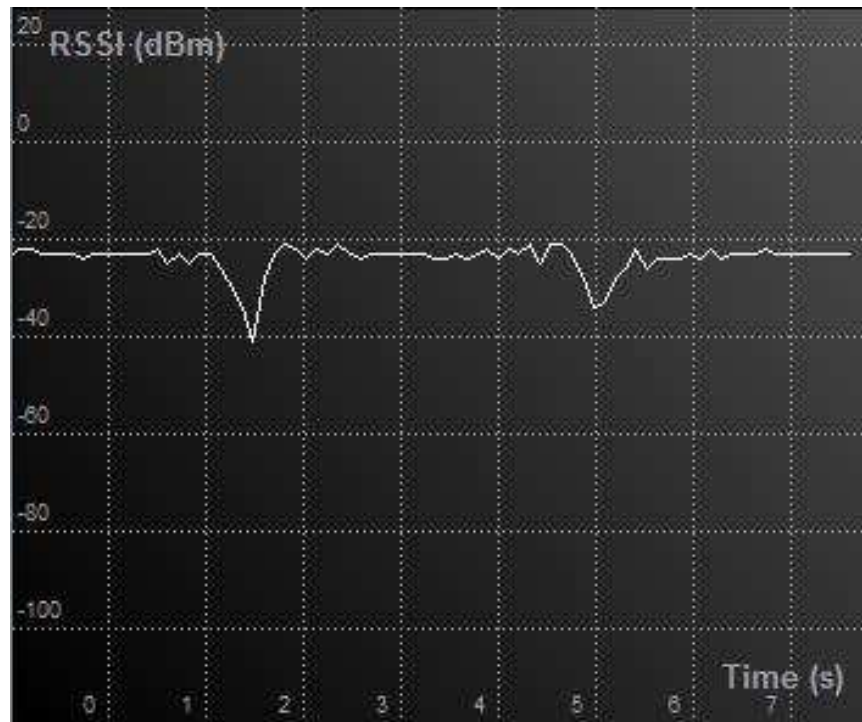

FIGURE 6-11: CHANNEL 0 WITH A 12 DBM INPUT SIGNAL AND A PERSON CROSSING THE LOS TWICE



FIGURE 6-12: CHANNEL 0 WITH A 0 DBM INPUT SIGNAL AND A PERSON CROSSING THE LOS TWICE

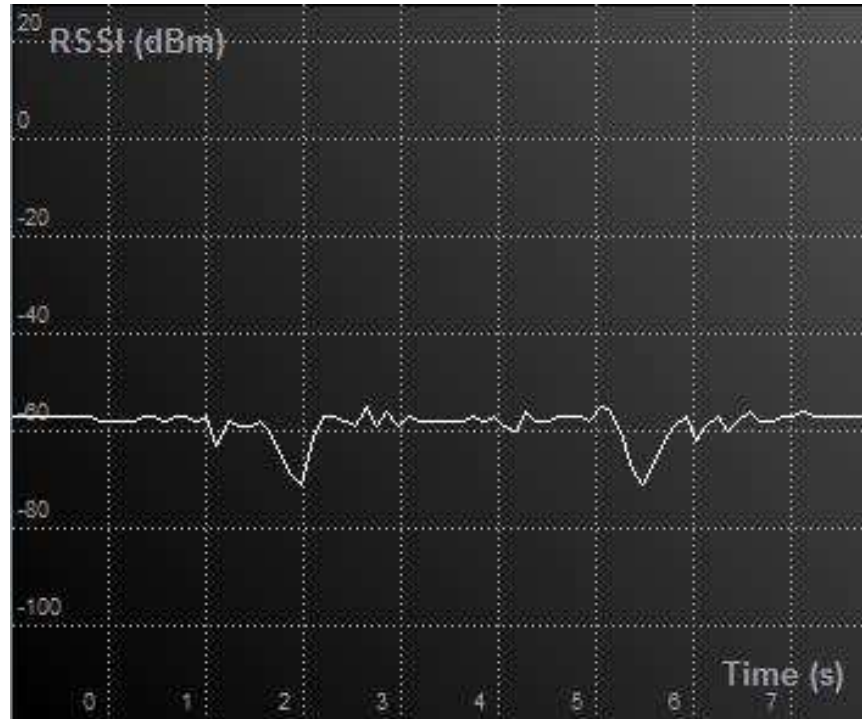

FIGURE 6-13: CHANNEL 0 WITH A -30 dBM INPUT SIGNAL AND A PERSON CROSSING THE LOS TWICE

#### 6.4.2.3 BANDWIDTH SETTING

With no input signal applied, the RSS levels for the RX's 58, 406.25 and 812.5 kHz bandwidth settings were measured and the means were -111, -104 and -76 dBm respectively, as shown in figures 6-14, 6-15 and 6-16.

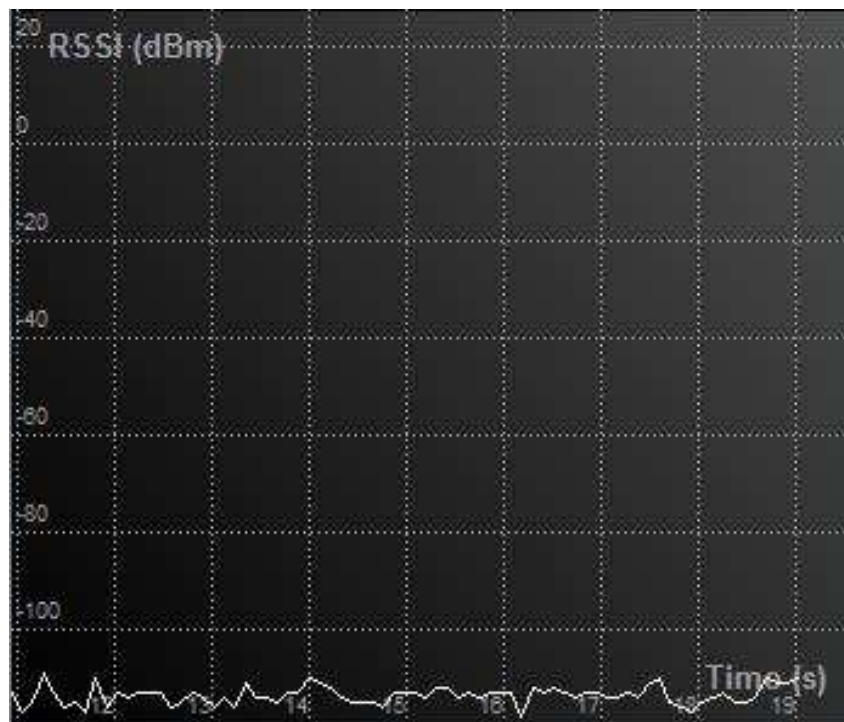

FIGURE 6-14: CHANNEL 0 AT 58 KHZ BANDWIDTH WITHOUT AN INPUT SIGNAL



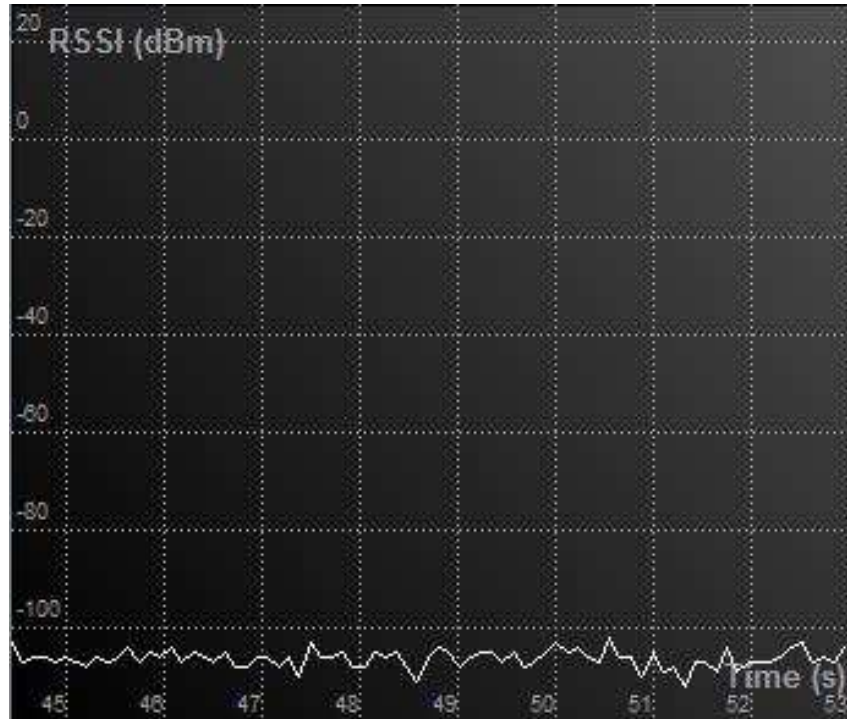

FIGURE 6-15: CHANNEL 0 AT 406.25 KHZ BANDWIDTH WITHOUT AN INPUT SIGNAL

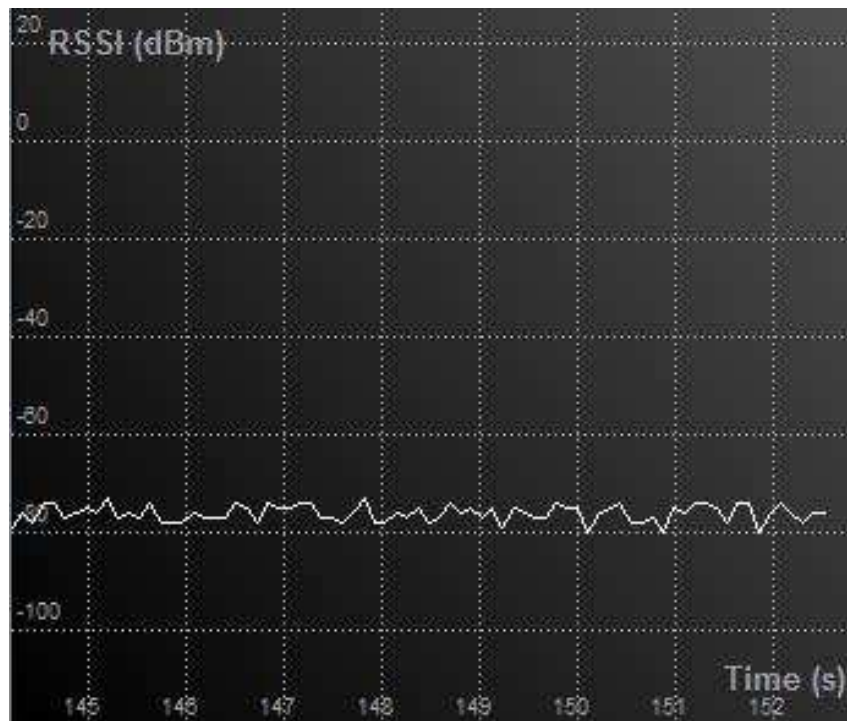

FIGURE 6-16: CHANNEL 0 AT 812.5 KHZ BANDWIDTH WITHOUT AN INPUT SIGNAL

The RSS measurements, which were recorded with an applied 0 dBm signal and whilst a person walked along the stated trajectory, are shown in figures 6-17, 6-18 and 6-19 for bandwidth settings 58, 406.25 and 812.5 kHz respectively.



FIGURE 6-17: CHANNEL 0, 0 DBM, 58 KHZ AND A PERSON CROSSING THE LOS TWICE

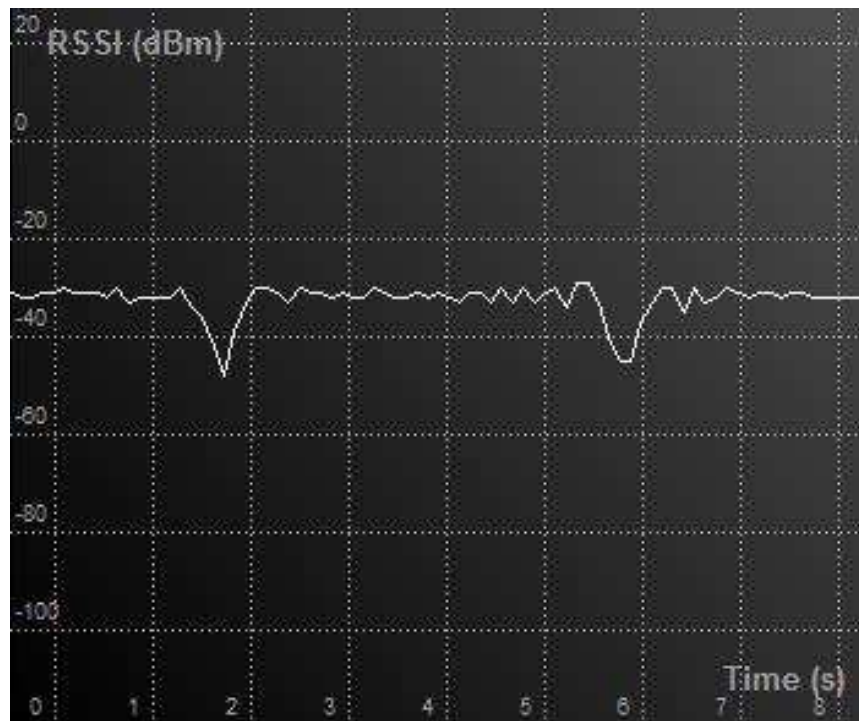

FIGURE 6-18: CHANNEL 0, 0 DBM, 406.25 KHZ AND A PERSON CROSSING THE LOS TWICE



FIGURE 6-19: CHANNEL 0, 0 DBM, 812.5 KHZ AND A PERSON CROSSING THE LOS TWICE

#### 6.4.3 DISCUSSION

The results showed that human movement is clearly distinguishable. All RSS measurements made whilst a person was moving had small ripples in comparison to the flat RSS signatures seen in figures 6-8 to 6-10. The size of those ripples in- and de-creased with the person moving closer to and further away from the signal's LOS. The largest impact on RSS was measured each time the participant crossed the LOS of the radio connection. With radio signals likely to travel via multiple paths, as described in chapter 5, the size of the less dominant ripples might correspond to human interference of less dominant signal paths.

Other factors, such as noise levels, could also influence the clarity of RSS responses. Channel 100, which seemed to record noise, as shown in figure 6-3, did not show as distinct troughs with human movement, depicted in figure 6-6, as comparative results throughout this experiment. Although, channel 50, which had no noise, showed a similar RSS response pattern, represented in figure 6-5, as channel 100. Hence, this could suggest that the corresponding frequencies, i.e. 878 and 888 MHz, react differently to human movement than those corresponding to channel 0 and channel 255. On the other hand, variables such as the movement



behaviour of the participant, could also have influenced the RSS response patterns seen for channel 50 and 100.

The RSS measurements without an applied signal seemed to increase with bandwidth setting, but as CC1101's datasheet [136] highlights, the receiver's sensitivity decreases inversely proportional to the bandwidth. Hence, those measurements do not represent noise, but the maximum sensitivity level. This is coherent with the fact that channel 0, which was used for the different bandwidth settings, also showed no noise, as stated in section 6.4.2.1. However, with an applied signal and human movement, no significant variations in RSS response could be identified with regards to bandwidth settings. This could indicate that although several frequencies react to human movement, the underlying effects might not be stackable, which would suggest that signal absorption by the human body is not the main factor. Chapters 7 to 9 investigated the signal propagation methods linked to DfL further.

Furthermore, the RSS response patterns to human movement for the three different input signals, represented in figures 6-11, 6-12 and 6-13, seemed relatively similar to each other. Hence, it could be suggested that Lymberopoulos et al.'s [100] and Christmann et al.'s [130] findings reported in chapter 5, that signal properties do not change with input power, can be applied to signal interferences caused by human movement.

However, a limitation of this experiment was the fact that screenshots needed to be made to record the data, which meant that a person had to be present. Hence, the difference between transmitted and received power, as shown in table 6-1, which was somewhat proportional to the input power, could either be related to the person present or due to signal fading. Also, comparing the measurements shown in figures 6-8, 6-9 and 6-10 to the means of figures 6-11, 6-12 and 6-13, to identify the static component of a person's presence, would not provide any information, as they shared the same bias. It is therefore suggested that a separate experiment should investigate the impact of human presence.

#### 6.4.4 CONCLUSION

The experiment demonstrated consistent responses with regards to human movement, especially the LOS proved very sensitive.

Different factors, which could influence signal responses were discussed. The findings of the experiment described in section 6.3, that DfL can be applied to a variety of frequencies, were confirmed. Also, it was shown that RSS signal patterns do not change with input signal strength or bandwidth. However, no deductions could be made with regards to human presence, due to the limitations of the experiment.

## 6.5 HUMAN PROXIMITY

The previous experiment, discussed in section 6.4, which found a clear correlation between human movement and RSS changes, proposed to investigate human presence. Many studies reviewed in section 5.3 focused on one or the other. Wilson and Patwari, who studied both, impacts of immobile [113] and mobile [119] humans on RSS, suggested that the position of the person in relation to the RX or TX also impacts RSS [126]. Hence, the following experiment was designed to confirm their findings whilst investigating immobile human presence.

### 6.5.1 METHODOLOGY

The two CC1101 radios were positioned in the same test environment as in the previous experiment, described in section 6.4 and the same default settings were used, i.e. channel 0, 0 dBm transmission power and 58 kHz bandwidth. The radios were operated in packet transmission mode to prevent the previous limitations of requiring a person to take screenshots of the data, as it allowed the computational storage of the RSS values of each packet.

Both radios were placed on two chairs of an approximate height of 0.6 m. Two scenarios were tested during which the radios were separated by a distance of either 2 or 4 m, as depicted in figures 6-20 and 6-21 respectively.

A person was asked to stand in seven different positions per scenario, marked as A, B, C, D, E, F and G in figures 6-20 and 6-21. Positions A and G corresponded to the person standing in the corners of the room, i.e. more than 2 m behind TX and RX respectively. From experience gathered during the previous

experiments, these two positions were estimated to be equivalent to no person being present.

For positions B, C, E and F the participant was asked to stand very close to the radios, without touching them. Position D corresponded to the halfway distance between TX and RX. Besides standing in this position, the participant was asked to squat, so that the majority of their body was not only in the LOS but also on the same height as the radios. This position was called D\*.

All positions were held for 15 s, which equalled approximately 50 transmitted packets. This procedure was repeated several times for the 2 m and the 4 m setup.

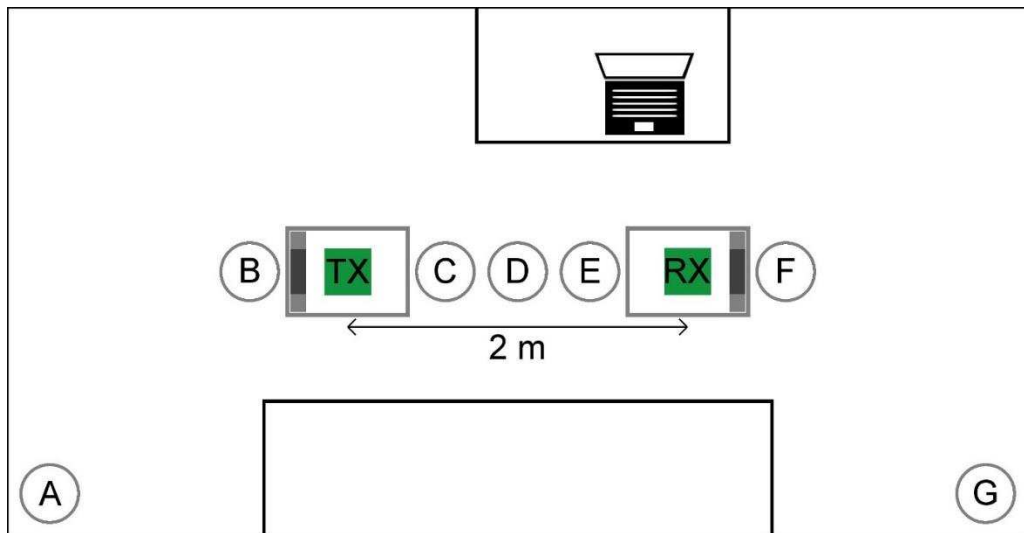

FIGURE 6-20: PERSON'S POSITIONS WITH TX AND RX BEING 2 M APART

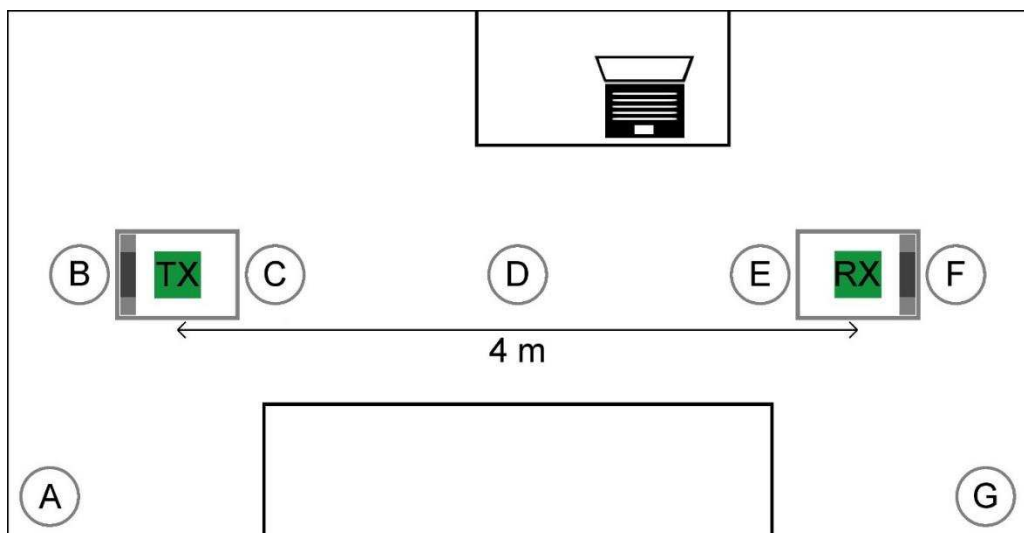

FIGURE 6-21: PERSON'S POSITIONS WITH TX AND RX BEING 4 M APART

6.5.2 RESULTS

The mean RSS values were calculated for each position the person stood or squatted in, and for both radio distance scenarios, as shown in table 6-2.

Mean RSS [dBm]		Person's Position							
		A	B	C	D	D*	E	F	G
Radio Distance	2 m	-37.7	-36.3	-47.1	-41.8	-47.1	-42.7	-36.9	-37.3
	4 m	-44.9	-45.2	-54.0	-53.9	-48.9	-53.9	-48.5	-44.8

TABLE 6-2: RSS VALUES FOR DIFFERENT POSITIONS OF HUMAN AND RADIOS

The mean values of position A's and position G's measurements were taken as references to represent in- or de-increases with regards to the remaining six positions for the 2 m and the 4 m scenarios, as shown in figure 6-22. This approach was supported by the fact that both positions yielded approximately equal RSS values within each scenario.

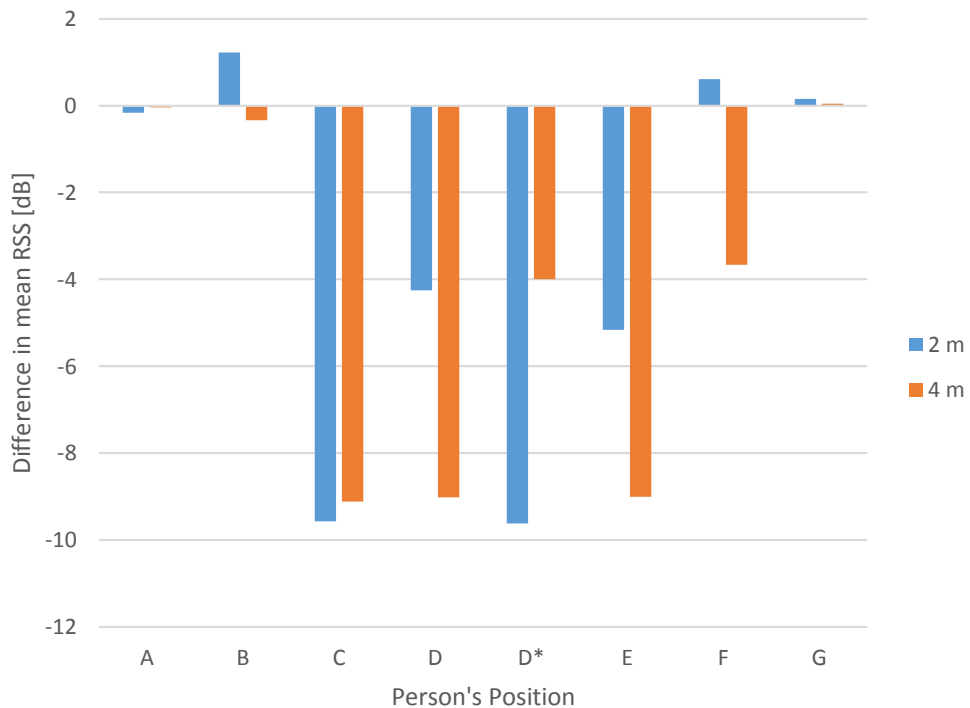

FIGURE 6-22: MEAN RSS VARIATIONS WITH REGARDS TO PERSON'S POSITION AND RADIO DISTANCES

6.5.3 DISCUSSION

The results showed that different positions along the linear plane of the LOS of a radio connection yielded different mean RSS values. During both, the 2 m and the 4 m test, significant lower RSS was measured when the person stood within the LOS. However, both

test scenarios reacted differently to a person standing behind either the TX or RX. As represented by positions B and F in figure 6-22, during the 2 m test the mean RSS increased, whereas during the 4 m test it decreased. Additional reflections of the transmitted signal caused by the human body and seen by the RX could be the cause for both effects. As mentioned in section 5.2, multipath components can be additive or subtractive dependent on their phase angle.

Also, during the 2 m test the impact on RSS was more significant when the person stood in front of TX rather than RX, as shown in figure 6-22 by positions C and E respectively. Position D, which corresponded to the participant standing in the middle of the LOS, yielded the lowest RSS decrease. However, during the 4 m test, all three of these positions resulted in similarly significant RSS reductions. This would support Wilson and Patwari's [126] findings that human interference impacts RSS differently depending on the ratio of radio height to link length, due to signal reflection and diffusion. However, their simulations and experiment did not include the previously seen increases with human presence behind radio transceivers.

The variations in RSS caused by a person standing or squatting in the LOS were also different for both scenarios. During the 2 m test the RSS decrease was larger with a person squatting rather than standing, as represented in figure 6-22 by positions D\* and D respectively. However, during the 4 m test this response pattern was inversed, and the RSS was significantly lower with a person standing rather than squatting. This suggests that the ratio of the human body's surface to the length of the radio link also influences RSS response, besides the previously mentioned ratio of radio height to link length.

Furthermore, it is noteworthy that whilst the mean RSS values for positions A and G were approximately 7 dB lower for the 4 m test compared to the 2 m test, as represented in table 6-2, the maximal variations in each of the two tests only had marginal differences in magnitude, as shown in figure 6-22. Hence, signal fading, which was probably responsible for the baseline difference, seems to have little effect on the absolute drop in RSS caused by human presence.

#### 6.5.4 CONCLUSION

The study demonstrated the impact of an immobile person on RSS and found that different positions taken on and behind the LOS yielded different results. It was confirmed that the ratio of radio height to link length influences whether the RSS responds most to a person standing close to the radio or in the middle of the LOS. Furthermore, it was suggested that the ratio of the human body's surface to the link length could influence RSS response. The study also showed indications that signal fading might not influence the absolute variations in RSS due to human presence. In summary, these observations suggest that DfL could potentially use relatively fine grained interpretation methods rather than relying on binary like responses only linked to whether or not the LOS is obstructed.

### 6.6 CHAPTER CONCLUSION

The experiments, described in this chapter, have established that DfL is possible and confirmed findings of studies undertaken by other researchers. It has been shown that all frequencies tested, many of which could be used for building wireless COAC systems, are sensitive to human movement. Simultaneously, it has been suggested that the amplitude of the input signal as well as the effect of signal fading do not influence the RSS response in relation to human interference.

The studies also demonstrated that the LOS of a communication link is particularly sensitive to human presence or movement. In addition, it has been shown that human presence along different parts of the LOS can potentially be differentiated depending on the ratio of radio height to link length. Furthermore, it has been suggested that the ratio of the human body's surface to the link length could influence RSS response patterns. Human presence behind the LOS as well as a human moving towards and away from a LOS of a communication link were also shown to cause changes in RSS. Hence, the potential for accurate DfL has been outlined, but further studies, especially in the context of COAC systems and multiple radios need to be conducted, which was done by chapters 7 to 9.

However, the experiments also highlighted limitations related to the equipment. To operate the CC1101 radios and collect their data, it was required to connect them via USB cables, which only permits for a limited number of experimental setups. Therefore, chapters 7 to 9, which further investigated the relationship of human interference and RSS, used different test equipment.

## **7 DFL – COMPREHENSIVE STUDY – PART A**

### **7.1 INTRODUCTION**

The principles of DfL, as highlighted by previous research mentioned in chapter 5, were experimentally confirmed in chapter 6. It was demonstrated that the direct LOS of a communication link as well as neighbouring areas were particularly sensitive to human movement and human presence. It was also shown that changes in transmitted signal strength did not influence the RSS response patterns. Furthermore, chapter 6 suggested that different frequencies react differently to human presence.

However, as mentioned in chapter 5, no evidence of previous research aimed at exploiting the wireless infrastructure of automation systems for DfL purposes was found. Hence, a comprehensive analysis described in this and the following two chapters, comprised of a series of experiments, was conducted to establish the capabilities of DfL in the context of COAC. The experiments were guided by the criteria outlined in section 3.4.2 and investigated DfL applied to domestic environments as well as optimal network layout and operation.

As chapter 6 pointed out limitations with the previously employed equipment, which reduces possible experimental setups, alternative radio equipment, described in section 7.2, was chosen for the following comprehensive study. With the signal transmission pattern being crucial to signal strength interpretation and hence to DfL, as mentioned in chapter 5, the antenna characteristics of the chosen radio equipment were studied first, followed by indoor signal propagation. Finally, this part of the comprehensive analysis investigated the relation between indoor radio deployment and human presence as well as human movement.



## 7.2 EQUIPMENT

Radios based on the IEEE 802.15.4 standard are ideal for the application in wireless domestic automation systems, as mentioned in section 3.3.2. Chapter 6 investigated the impact of human interference in all frequency bands of this standard except the 2.4 GHz range. Also, as mentioned in section 5.2, water has a particularly high relative permittivity at 2.4 GHz, which suggests larger RSS responses to human presence. Hence, radio equipment using the IEEE 802.15.4 standard and operating in this frequency range was chosen.

CC2420 radio chips [137] were used by the majority of research studies reviewed in chapter 5 and are very common in the automation sector. They can be operated between 2400 MHz and 2483.5 MHz, and with output powers between -24 dBm and 0 dBm [137]. Hence, a readily available integrated radio system with an embedded CC2420 chip was chosen for this comprehensive study, called TelosB mote.

TelosB motes, as depicted in figure 7-1, have a MSP430 microcontroller, a printed on inverted-F antenna and a USB connector, amongst others. A mote can be programmed using the nesC language and the programs can be upload and run via the USB port. The USB connection can simultaneously power the TelosB mote or two AA batteries can be used.

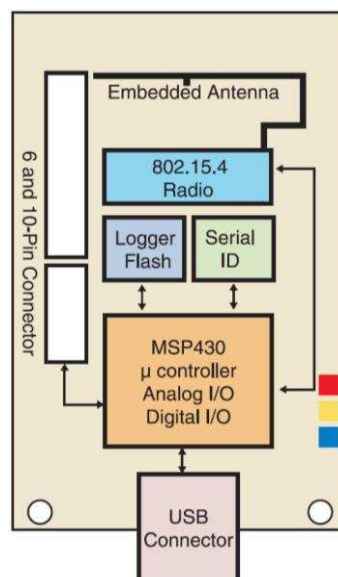

FIGURE 7-1: TELOS B BLOCK DIAGRAM [138, P.1]

As chapter 6 demonstrated that DfL can be applied to a variety of frequencies and that signal properties do not change with transmitted power, the TelosB motes were set to 2.4 GHz and 0 dBm respectively for all subsequent experiments.

Also, CC2420 radio chips measure RSS with an offset of approximately 45 dBm [137], which was subtracted to obtain the true received power value.

For the purpose of describing the experiments undertaken during this comprehensive study, particular TelosB motes were referred to as “M” followed by their number. Furthermore, in each of the tests the mote M0 was defined as stationary, setup as a RX, connected to a computer via a USB cable and thus forwarding the RSS. In addition, a communication link between a TX, e.g. M1, and a RX, e.g. M0, was noted as  $L_{M1 \rightarrow M0}$ .

### 7.3 ANTENNA ASSESSMENT

Before DfL can be researched further using the TelosB motes, the motes themselves need to be understood, especially their antennas’ transmitting and receiving patterns. Obstructing the LOS of a communication link had the greatest impact on RSS in the experiments described in chapter 6. However, monopole antennas were used, whose radiation pattern can be assumed symmetrical. As mentioned in section 7.2, TelosB motes have inverted-F antennas, which are an integral part of their circuit boards, thus making their radiation pattern hardly predictable as it might be influenced by other electronic parts. Hence, the LOS of a communication link between two TelosB motes might not necessarily correspond to the strongest connection path. Therefore, two consecutive experiments were conducted to assess the uniformity of a mote’s radiation pattern.

#### 7.3.1 2D EXPERIMENT

The first experiment was designed to establish the dominant transmission path of TelosB motes on a two dimensional plane. A simple methodology and statistical analysis tools were used for this purpose.

## 7.3.1.1 METHODOLOGY

Two motes, called M0 and M1, were positioned 0.5 m apart from each other on a table surface. M1 was set to transmit a signal and as per definition M0 was set to receive the signal and forward the measured RSS to a computer.

During this test M1 was rotated three times, once around each of its axes, as represented by figure 7-2. The x-axis rotation, called Rot-X, was performed with the mote's y-z plane parallel to the table surface. M1 was rotated in 45° steps, with the position corresponding to 0° representing M0's and M1's antennas facing each other. The y-axis rotation, called Rot-Y, used the same initial position, however 90° step sizes were used, as only those intervals permitted a stable mote position. The z-axis rotation, called Rot-Z, was conducted with M1's x-y plane parallel to the table surface. 45° steps were used, with the 0° position corresponding to M0's and M1's antennas facing each other. All rotations were undertaken anticlockwise and the radios were operated for approximately 30 s per position to gather 100 measurements.

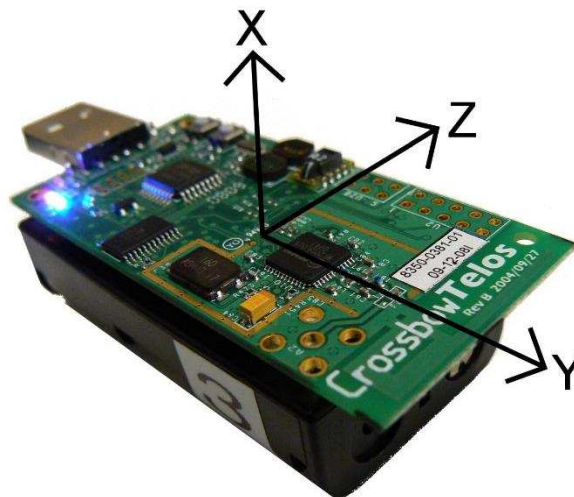

FIGURE 7-2: AXES ASSIGNED TO TELOS B MOTE

## 7.3.1.2 RESULTS

The mean RSS and standard deviation for the 100 measurements were calculated for each of the positions. They are represented in table 7-1 and table 7-2 respectively. Figures 7-3, 7-4 and 7-5 represent the mean and standard deviation for the tests Rot-X, Rot-Y and Rot-Z respectively. The axis values of the standard deviations were reversed in order to highlight the relation.

Mean [dBm]		Angle of Rotation							
		0°	45°	90°	135°	180°	225°	270°	315°
Test	Rot-X	-31.1	-29.2	-37.7	-29.0	-39.0	-37.2	-50.9	-34.4
	Rot-Y	-31.1	-	-32.9	-	-50.2	-	-39.0	-
	Rot-Z	-32.0	-31.1	-31.0	-28.0	-31.0	-32.9	-38.0	-30.0

TABLE 7-1: MEAN RSS MEASUREMENTS FOR ROT-X, ROT-Y AND ROT-Z TESTS

Standard Deviation [dBm]		Angle of Rotation							
		0°	45°	90°	135°	180°	225°	270°	315°
Test	Rot-X	0.29	0.39	0.87	0.00	0.41	0.96	1.58	0.91
	Rot-Y	0.24	-	0.33	-	1.26	-	0.28	-
	Rot-Z	0.10	0.30	0.00	0.00	0.17	0.26	0.00	0.00

TABLE 7-2: STANDARD DEVIATION OF RSS MEASUREMENTS FOR ROT-X, ROT-Y AND ROT-Z TESTS

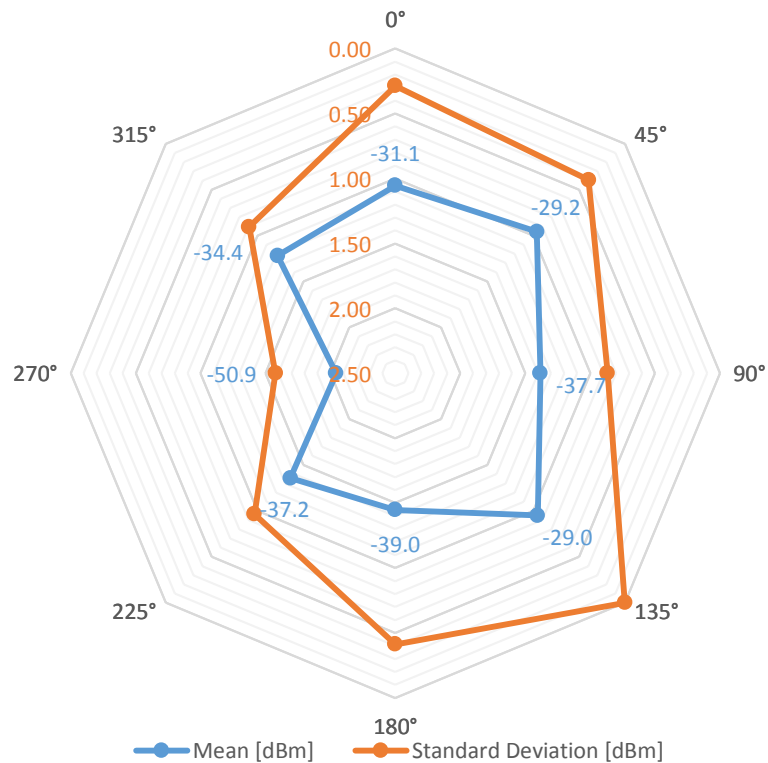

FIGURE 7-3: MEAN AND STANDARD DEVIATION OF RSS FOR EACH POSITION DURING ROT-X TEST

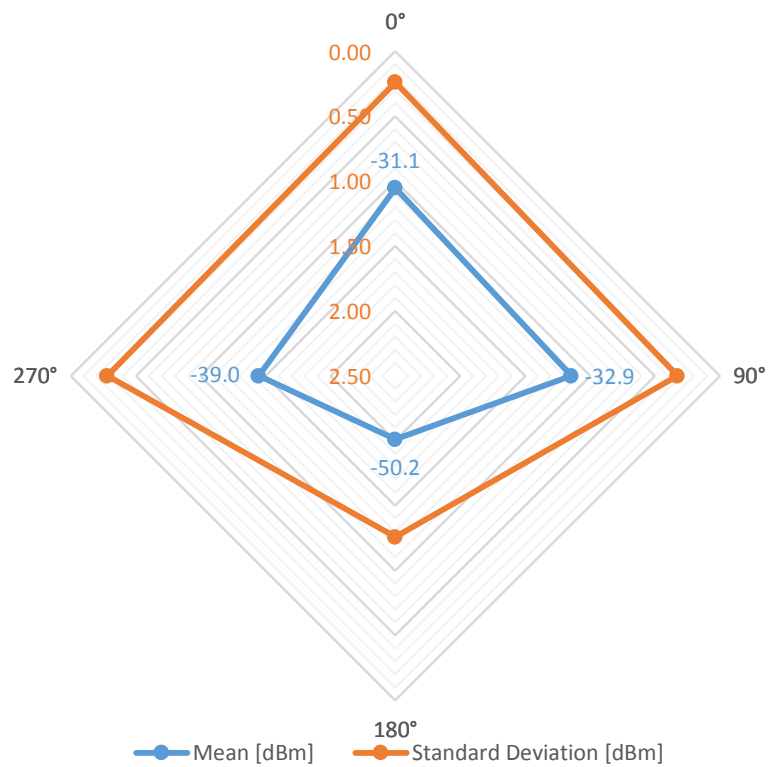

FIGURE 7-4: MEAN AND STANDARD DEVIATION OF RSS FOR EACH POSITION DURING ROT-Y TEST

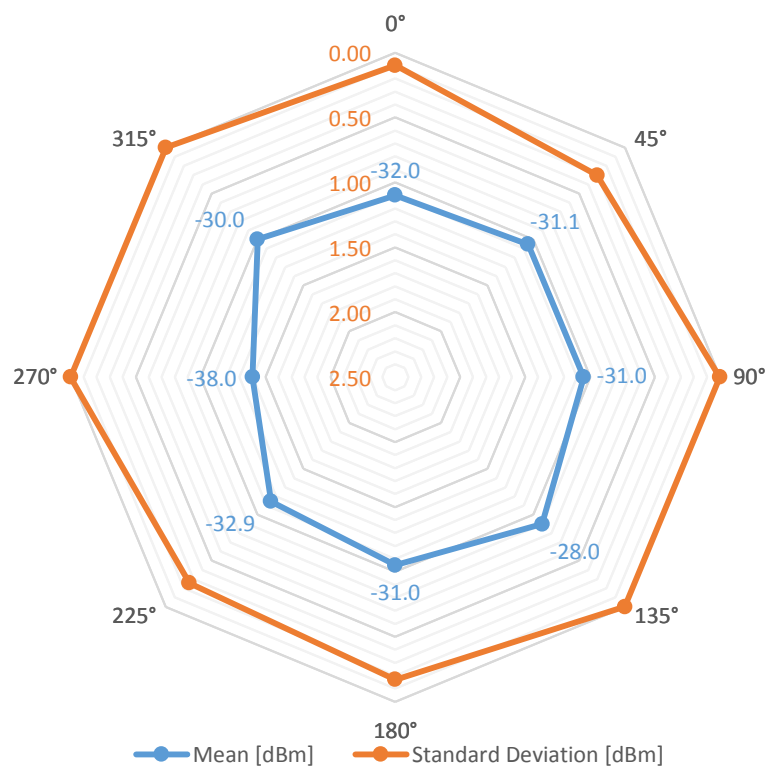

FIGURE 7-5: MEAN AND STANDARD DEVIATION OF RSS FOR EACH POSITION DURING ROT-Z TEST

### 7.3.1.3 DISCUSSION

During the Rot-X test the best reception occurred for the angles  $0^\circ$ ,  $45^\circ$  and  $135^\circ$ , as shown in figure 7-3. The  $270^\circ$  angle on the other hand showed very low reception with a mean RSS of  $-50.9$  dBm. Furthermore, the  $1.58$  dBm standard deviation at  $270^\circ$  suggests that the RSS was spread over a wider spectrum, which in turn could indicate the presence of multiple signal fractions. In fact, this relation between elevated standard deviation and diminished mean RSS seemed somewhat consistent for the tests Rot-Y and Rot-Z as well, as shown in figures 7-4 and 7-5 respectively. A correlation between both sets of values for all three rotations combined revealed a coefficient of  $-0.78$ , indicating a negative correlation. Signals interacting with the table surface or other parts in the test environment, could have caused reflections or other phenomena, described in section 5.2. Thus created multipath propagation might have been responsible for the negative correlation. This suggests that the LOS of a communication link which displayed an elevated standard deviation was not the only dominant connection path.

Besides the interference of the two dimensional surface plane, another limitation of this experiment was the dependence on stable mote positions, which inhibited the  $45^\circ$  step sizes for the Rot-Y test and the use of the same initial reference position for all three rotations.

### 7.3.2 3D EXPERIMENT

Based on the previous experiment, described in section 7.3.1, another one was designed to eliminate the mentioned limitations of the immediate presence of a potentially reflective surface and the two dimensional rotation possibilities. Simultaneously, this three dimensional experiment sought to confirm previous findings. Also, as the experiment described in section 7.3.1 only evaluated the transmission and not the reception pattern, the link symmetry of TelosB motes was investigated in the following experiment.

#### 7.3.2.1 METHODOLOGY

Three motes, called M0, M1 and M2, were positioned in a straight line. M0 was placed on a table and connected to a computer via a USB cable. M1 was placed at a  $1.2$  m distance of M0 and at a height of  $1.5$  m with respect to the floor. M2 was suspended from the

ceiling at that same height level and was 0.5 m apart from M1, as in the previous experiment described in section 7.3.1. The antennas of M0 and M1 faced M2.

During the experiment M2 was rotated anticlockwise in 90° steps around its x-, y- and z-axis, shown in figure 7-2. Other step sizes would not have allowed a stable mote position due to the suspension method used. Also, not all 56 possible angle combinations were measured, as some would have yielded the same final position. The reference position corresponding to  $x = 0^\circ$ ,  $y = 0^\circ$  and  $z = 0^\circ$  had M2's y-z plane parallel to the floor with the batteries at the bottom and its antenna facing M0 and M1.

As per definition which was highlighted in section 7.2, M0 was setup as a RX. M1 and M2 were both setup as transceivers. They sent packets to each other and once they received the one from the other mote, they forwarded the RSS value to M0. Thus, four communication links with their respective RSS were established, called  $L_{M1 \rightarrow M2}$ ,  $L_{M2 \rightarrow M1}$ ,  $L_{M1 \rightarrow M0}$  and  $L_{M2 \rightarrow M0}$ . As in the previous experiment from section 7.3.1, sets of 100 consecutive measurements were taken for each position.

#### 7.3.2.2 RESULTS

The mean RSS values and the standard deviation of each set of measurements were calculated.

The link  $L_{M1 \rightarrow M0}$ , which was not modified throughout the experiment and thus acted as a reference, showed consistent mean RSS values between -44.5 and -41.6 dBm. Its standard deviation was between 0.14 and 0.74 dBm. Based on those values, the precision range for this experiment can be assumed as  $\pm 1.5$  dB for the mean and  $\pm 0.30$  dB for the standard deviation.

The link symmetry between  $L_{M1 \rightarrow M2}$  and  $L_{M2 \rightarrow M1}$  was considered significant, as the mean RSS values correlated with a coefficient of 0.99 and the standard deviation with a coefficient of 0.90. Additionally, their absolute values were very similar, which was highlighted by representing the difference between  $L_{M1 \rightarrow M2}$ 's and  $L_{M2 \rightarrow M1}$ 's mean and standard deviation values in table 7-3. Hence, only the values for  $L_{M2 \rightarrow M1}$  and  $L_{M2 \rightarrow M0}$  were represented in figures 7-6 to 7-11 as these links did not demonstrate any significant correlation.

Difference between $L_{M1 \rightarrow M2}$ and $L_{M2 \rightarrow M1}$		Mean [dB]				Standard Deviation [dB]			
Y	Z	X				X			
		0°	90°	180°	270°	0°	90°	180°	270°
0°	0°	-0.3	0.1	0.4	0.6	-0.03	0.03	-0.02	0.28
90°	0°	-0.3	-1.1	-0.4	0.0	-0.16	-0.26	0.06	-0.05
180°	0°	0.2	0.6	-1.2	0.1	-0.24	-0.01	0.10	-0.23
270°	0°	-1.5	-1.3	-1.0	-1.3	-0.50	-0.36	-0.03	0.03
0°	90°	-1.1	-1.0	-0.7	-1.0	-0.08	0.12	0.40	-0.01
0°	270°	-1.2	-0.5	-1.0	-1.3	0.15	0.42	-0.05	0.02

TABLE 7-3: DIFFERENCE BETWEEN  $L_{M1 \rightarrow M2}$ 'S AND  $L_{M2 \rightarrow M1}$ 'S MEAN AND STANDARD DEVIATION

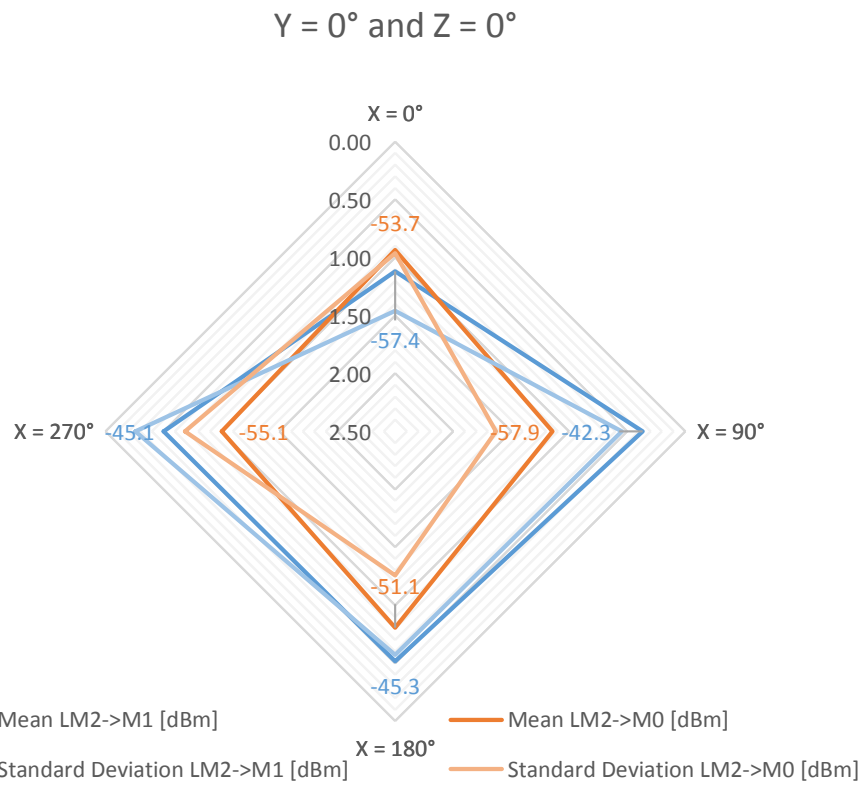

FIGURE 7-6: MEAN AND STANDARD DEVIATION OF  $L_{M2 \rightarrow M1}$  AND  $L_{M2 \rightarrow M0}$  FOR  $Y = 0^\circ$  AND  $Z = 0^\circ$



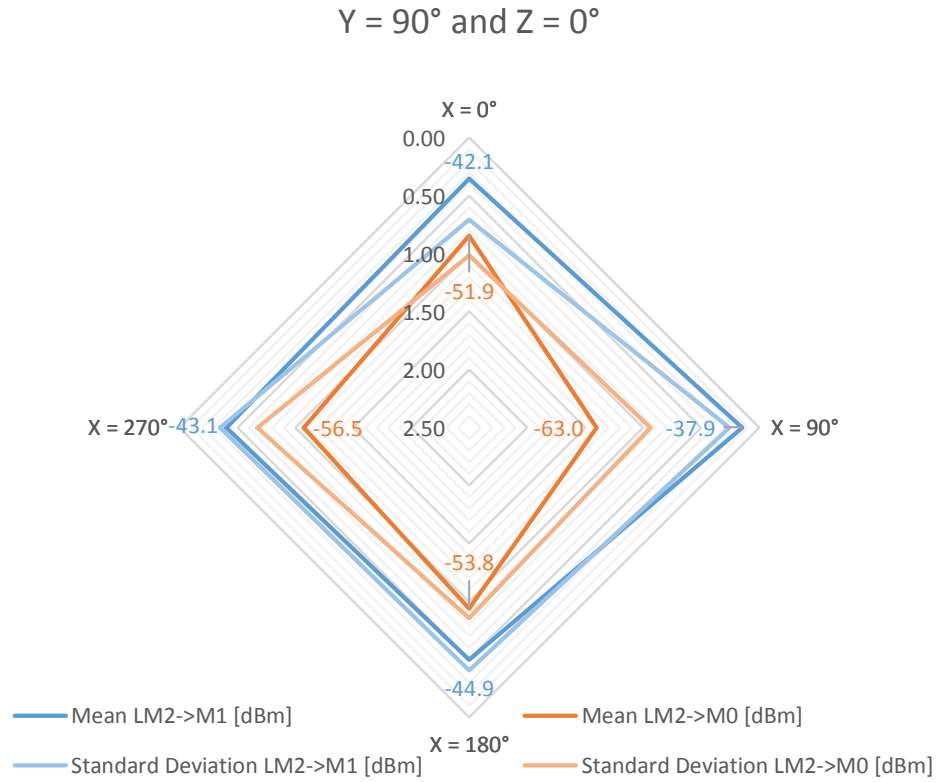

FIGURE 7-7: MEAN AND STANDARD DEVIATION OF  $L_{M2 \rightarrow M1}$  AND  $L_{M2 \rightarrow M0}$  FOR  $Y = 90^\circ$  AND  $Z = 0^\circ$

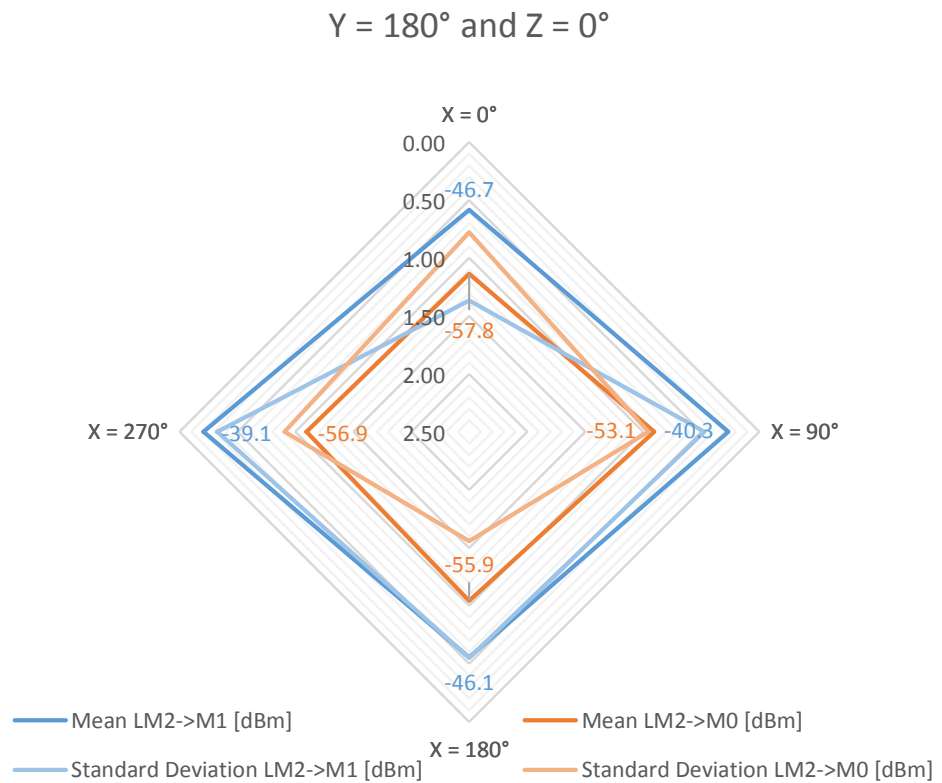

FIGURE 7-8: MEAN AND STANDARD DEVIATION OF  $L_{M2 \rightarrow M1}$  AND  $L_{M2 \rightarrow M0}$  FOR  $Y = 180^\circ$  AND  $Z = 0^\circ$

Y = 270° and Z = 0°

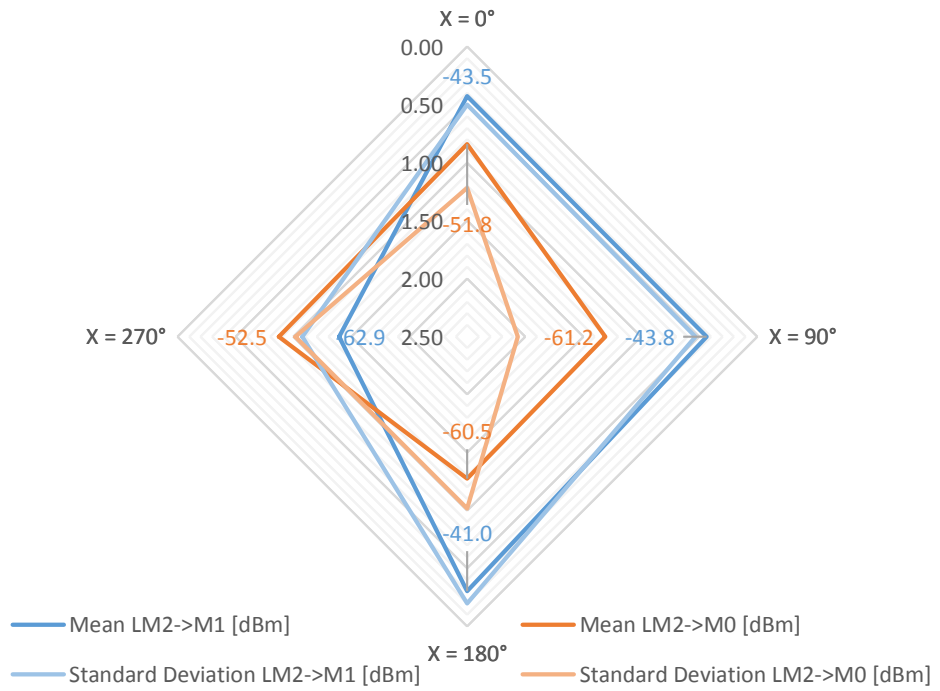

FIGURE 7-9: MEAN AND STANDARD DEVIATION OF  $L_{M2 \rightarrow M1}$  AND  $L_{M2 \rightarrow M0}$  FOR  $Y = 270^\circ$  AND  $Z = 0^\circ$

Y = 0° and Z = 90°

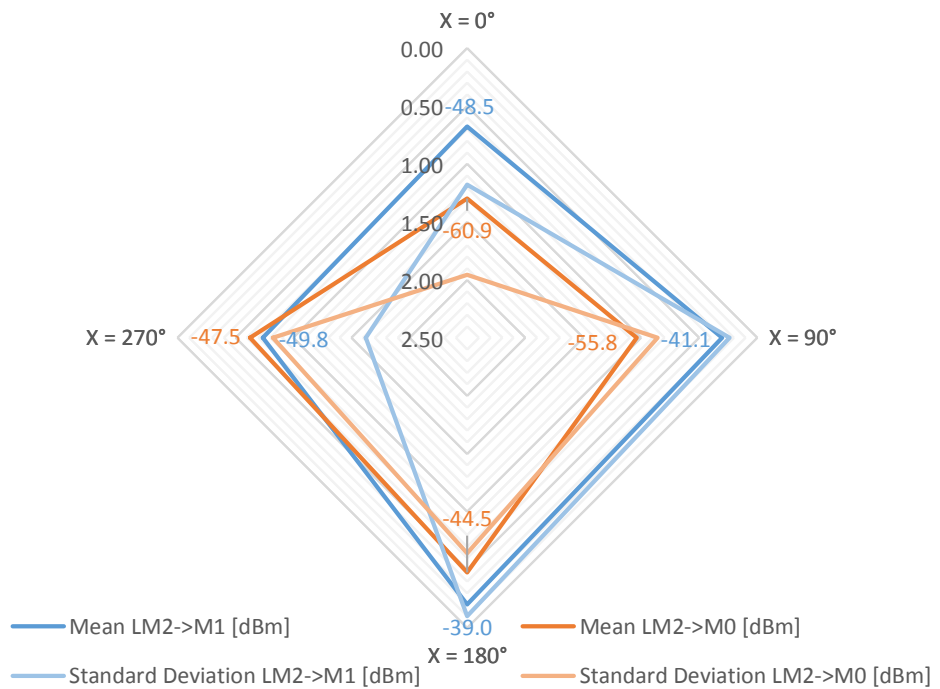

FIGURE 7-10: MEAN AND STANDARD DEVIATION OF  $L_{M2 \rightarrow M1}$  AND  $L_{M2 \rightarrow M0}$  FOR  $Y = 0^\circ$  AND  $Z = 90^\circ$

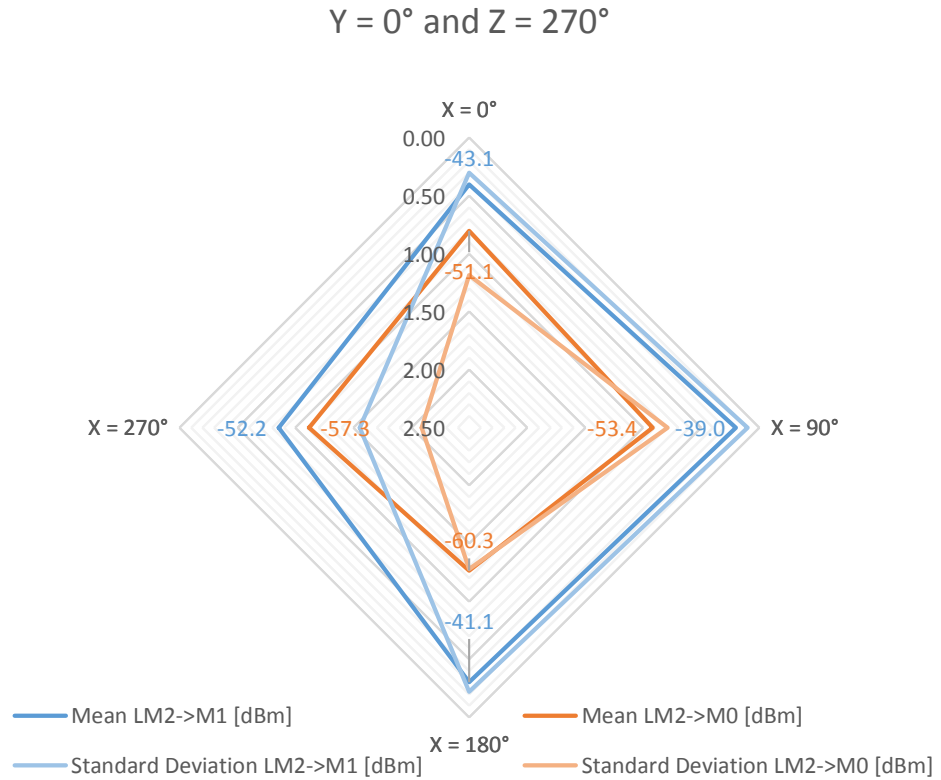

FIGURE 7-11: MEAN AND STANDARD DEVIATION OF  $L_{M2 \rightarrow M1}$  AND  $L_{M2 \rightarrow M0}$  FOR  $Y = 0^\circ$  AND  $Z = 270^\circ$

### 7.3.2.3 DISCUSSION

Figures 7-6 to 7-11 confirmed the negative correlation between mean and standard deviation observed during the previous experiment, described in section 7.3.1. The correlation coefficient of the mean and standard deviation of  $L_{M2 \rightarrow M1}$  was -0.77, which is comparable to the -0.78 value seen in the previous experiment. In contrast, the correlation coefficient for  $L_{M2 \rightarrow M0}$ 's values was -0.44. This could suggest that the observed negative correlation between mean and standard deviation might be less dominant with radios being placed further apart. Amongst others a cause for this could be the fading of reflected or diffused signal fractions.

The absolute values of mean RSS of both experiments did not support each other as the same angles yielded different results. For this purpose figure 7-6 was compared to Rot-X, figure 7-7 to Rot-Z and the  $x = 0^\circ$  values of figures 7-6 to 7-9 to Rot-Y.  $L_{M2 \rightarrow M1}$ , which had the same 0.5 m distance between TX and RX as the previous experiment, showed mean RSS values between 5 and 26 dB lower than the three rotational tests carried out in section 7.3.1. Also, the values measured per position for both experiments did not show

any sign of correlation. Similar observations were made when  $L_{M2->M0}$  was compared to Rot-X, Rot-Y and Rot-Z. Differences between the environments the two experiments were conducted in could have caused this diverging response pattern, especially the reflective surface in the experiment of section 7.3.1.

Also, the results suggested that the TelosB motes have similar transmitting and receiving antenna patterns. The link symmetry between  $L_{M1->M2}$  and  $L_{M2->M1}$  had significant mean and standard deviation correlation coefficients, as mentioned in section 7.3.2.2. Furthermore, the differences between both variables, represented in table 7-3, ranged from -1.5 to 0.6 dB for the mean and from -0.50 to 0.42 dB for the standard deviation. These values were respectively within and near the precision range deduced from  $L_{M1->M0}$  in section 7.3.2.2 of  $\pm 1.5$  dB for the mean and  $\pm 0.30$  dB for the standard deviation. This confirms Srinivasan's and Levis's [139] findings, who compared CC2420 radio chips with previous models and demonstrated that it had superior link symmetry.

### 7.3.3 CONCLUSION

A significant link symmetry between transmitting and receiving antenna patterns was established, which suggests that following experiments do not need to differentiate between the two.

Also, the results of the 2D and 3D experiments demonstrated a negative correlation between mean RSS and its standard deviation, which seemed to decrease with distance and was most likely related to multipath transmissions and fading effects introduced by the environment. If it can be demonstrated that the same phenomena are responsible for the decrease in absolute RSS values with human presence, then the analysis of the standard deviation of RSS value sets might be another available tool to DfL.

However, the antenna patterns measured in the 2D and 3D experiments did not support each other, which was probably caused by differences in the test environments. Hence, no definite conclusions can be drawn with respect to a TelosB mote's strongest transmission path.

## 7.4 INDOOR SIGNAL PROPAGATION

The previous antenna assessment, described in section 7.3, showed inconclusive findings, which was most likely due to signal interferences caused by the test environments. It also suggested a negative correlation between mean RSS and its standard deviation and indicated that it might reduce with distance. Therefore, and also with regards to the application of DfL to domestic COAC, the signal propagation in indoor environments was investigated using a set of experiments.

### 7.4.1 METHODOLOGY

A room 8.94 m long, 5.60 m wide and 2.45 m high was partitioned into 40  $1 \text{ m}^2$  reference points, i.e. (1,1) to (8,5). M0 was placed in the middle of position (1,1) with its y-axis, as seen in figure 7-2, in parallel to the room's x-axis and its antenna facing the opposing wall. A TX, M1, was placed sequentially in the middle of all remaining positions.

Three different setups were tested. During Setup-A, M1 mirrored M0 thus its antenna faced the wall behind M0. During Setup-B, M1's antenna faced M0 directly. For both, Setup-A and Setup-B, both motes were placed on the floor. During Setup-C, M1's antenna was in the same position as during Setup-A, but both motes were raised by 1.5 m using tripods. As in previous experiments, 100 measurements were taken per position. Also, Setup-A was tested twice on two separate days.

Furthermore, as the experiment involved repetitive placing of motes, a separate test was carried out beforehand to quantify the associated error margin. During this test, called RP test, M1 was placed alternately on positions (2,1) and (8,1) and 100 measurements were taken for both positions. This procedure was repeated five times.

### 7.4.2 RESULTS

The results of the RP test revealed that the mean RSS values for position (2,1) varied between -55.5 and -53.7 dBm and those for position (8,1) between -72.4 and -69.2 dBm. Hence, the human error associated with placing the motes during the indoor signal propagation experiments was estimated to be  $\pm 1.3 \text{ dB}$  for all

positions. The standard deviation across the five sets were 1.03 and 1.29 for position (2,1) and position (8,1), respectively.

The mean RSS per position for the signal propagation experiment using Setup-A to Setup-C were represented in figures 7-12 to 7-15. The differences between Setup-A(2), Setup-B and Setup-C with respect to Setup-A were highlighted in tables 7-4, 7-5 and 7-6, respectively. Those table's mean variation per position was -0.3, -1.9 and -11.1 dB in respective order.

Furthermore, the correlation coefficient between the mean and the standard deviation of Setup-A, Setup-A(2), Setup-B and Setup-C was -0.53, 0.08, -0.36 and 0.04, respectively.

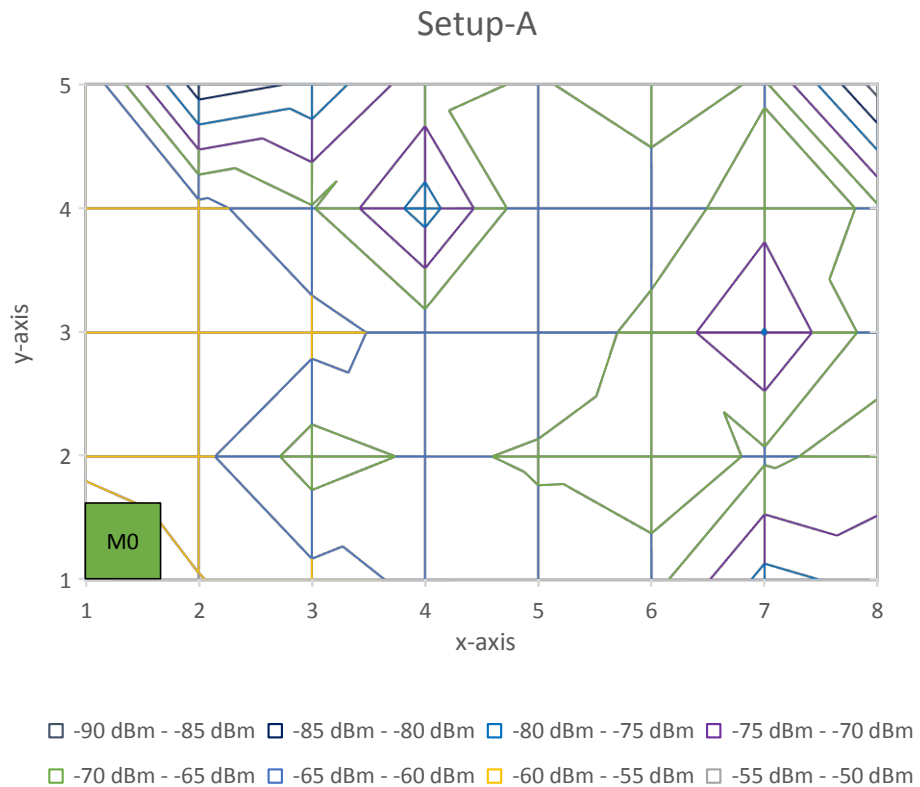
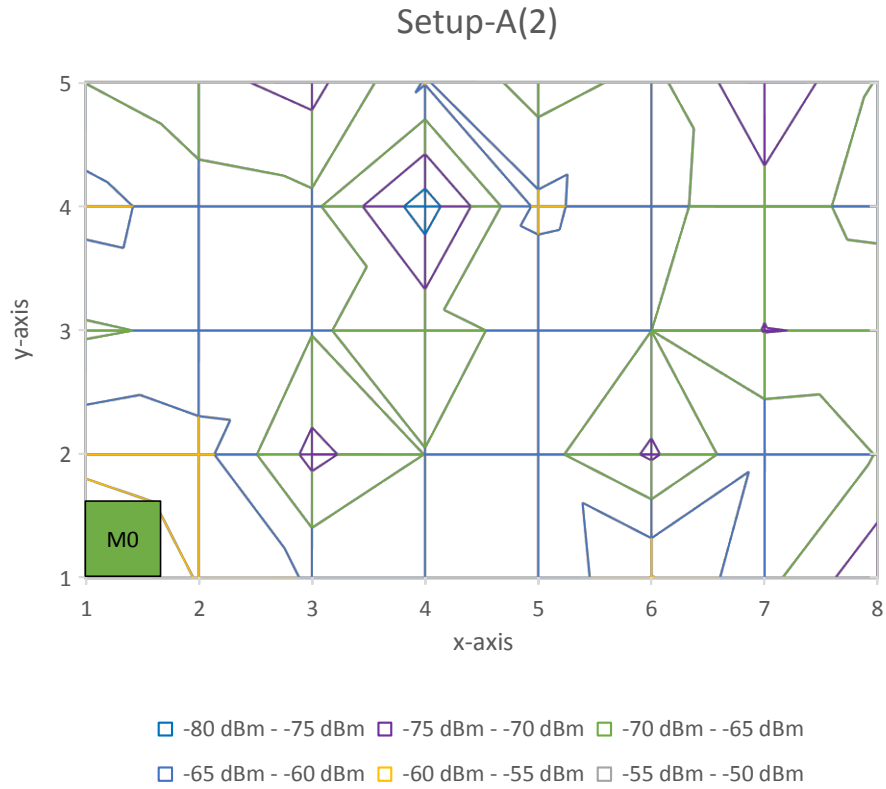
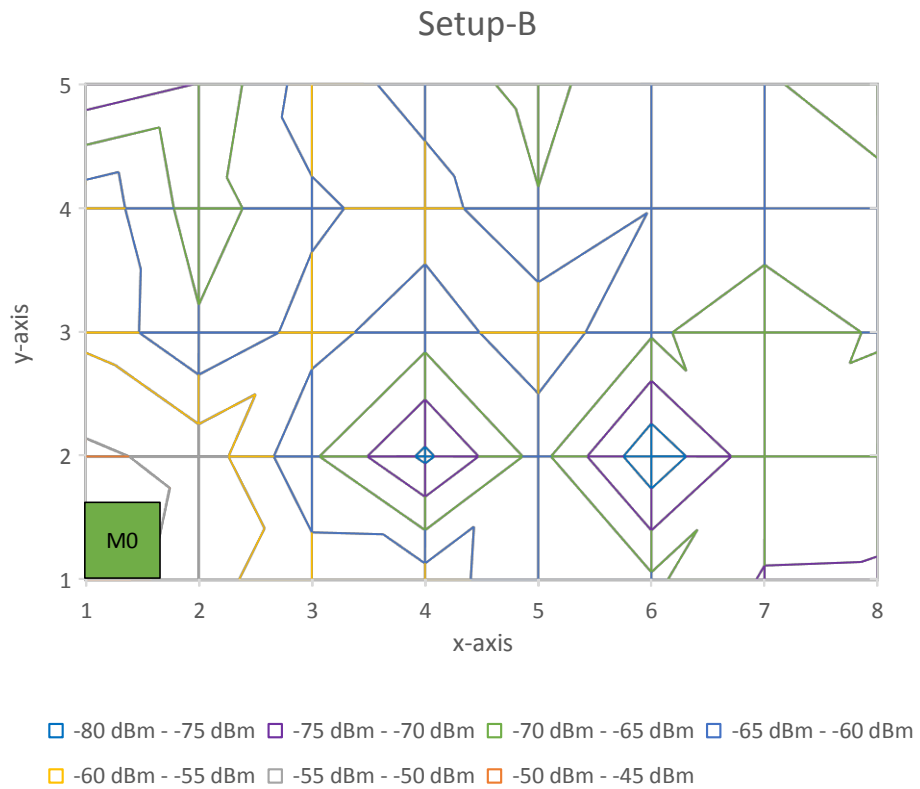

FIGURE 7-12: RSS PER POSITION FOR SETUP-A



**FIGURE 7-13: RSS PER POSITION FOR SETUP-A(2)**



**FIGURE 7-14: RSS PER POSITION FOR SETUP-B**

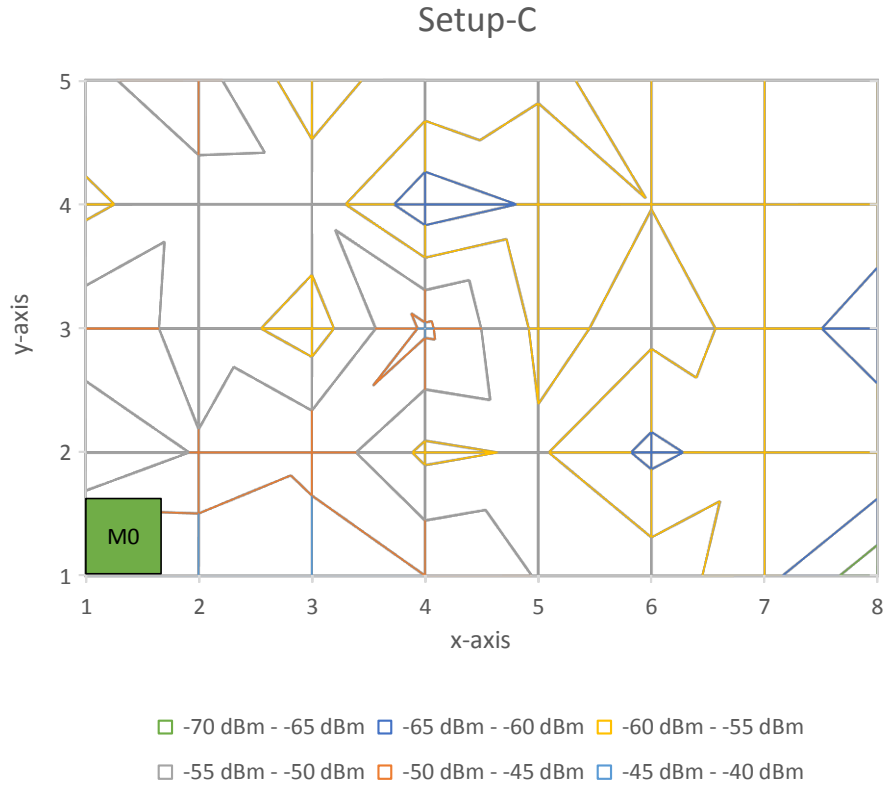

FIGURE 7-15: RSS PER POSITION FOR SETUP-C

Setup-A –		X							
Setup-A(2) [dB]		1	2	3	4	5	6	7	8
Y	1	-	0.5	2.1	3.5	1.2	-8.1	-13.3	0.7
	2	0.0	-0.6	4.0	0.8	-2.3	2.4	-3.3	-1.8
	3	9.7	6.2	6.7	4.1	2.5	-1.6	-5.1	6.7
	4	1.9	4.6	-0.8	0.2	-1.4	1.5	-0.3	-1.1
	5	9.8	-14.5	-7.3	-6.6	2.9	-4.7	10.3	-22.7

TABLE 7-4: DIFFERENCE BETWEEN SETUP-A AND SETUP-A(2)

Setup-A –		X							
Setup-B [dB]		1	2	3	4	5	6	7	8
Y	1	-	-1.1	-1.1	-3.3	0.6	1.1	-6.2	-2.7
	2	-7.3	-7.0	-3.2	11.9	-2.3	10.5	2.2	0.4
	3	0.2	6.4	0.2	0.8	-4.6	-2.1	-7.6	1.8
	4	-0.1	9.3	-3.7	-19.7	4.3	-2.0	-5.3	-1.6
	5	18.5	-13.2	-21.8	-4.3	2.3	-7.5	0.0	-18.8

TABLE 7-5: DIFFERENCE BETWEEN SETUP-A AND SETUP-B



Setup-A –		X							
Setup-C [dB]		1	2	3	4	5	6	7	8
Y	1	-	-14.5	-15.5	-15.9	-12.8	-10.8	-18.2	-5.0
	2	-1.7	-9.2	-21.4	-8.0	-11.2	-7.2	-7.3	-12.0
	3	-9.3	-6.1	-0.4	-18.1	-5.4	-12.8	-19.3	1.3
	4	0.2	-6.9	-13.1	-14.2	-1.0	-7.0	-10.4	-8.3
	5	-4.4	-35.2	-20.9	-15.3	-10.5	-11.1	-6.4	-29.3

TABLE 7-6: DIFFERENCE BETWEEN SETUP-A AND SETUP-C

### 7.4.3 DISCUSSION

The results demonstrated that the signal pattern in an indoor environment was not linear in relation to distance. All figures, i.e. 7-12 to 7-15, show non-uniform RSS distributions. Variations in antenna orientation did not reduce this phenomenon. Hence, interferences caused by walls and other objects in the test environment were most likely the source rather than the antenna pattern.

A limitation of this experiment was that the duration of each test only allowed for one test per day and that the room had to be rearrange between them. This could have caused the significant difference between Setup-A and Setup-A(2). 74 percent of mean RSS values of table 7-4 were beyond the  $\pm 1.3$  dB precision range established by the RP test. However, table 7-4 had the lowest mean variation per position, which was with  $-0.3$  dB within that precision range. Hence, an absolute power balance approach could be plausible with regards to DfL, which analyses the overall signal power in a room distributed over several radios rather than individual communication links.

Also, the negative correlation between mean RSS and standard deviation, described in section 7.3, could not be confirmed. In the previous section it was suggested that this correlation might decrease with distance, as a coefficient of  $-0.77$  was found for a  $0.5$  m link and a coefficient of  $-0.44$  for a  $1.4$  m link. The  $-0.56$  coefficient calculated for Setup-A, which covered  $1$  m to  $9.4$  m communication links, was therefore a strong mean. However, the inconsistency of the other three setups, which found coefficients between  $-0.36$  and  $0.04$ , as mentioned in section 7.4.2, did not

seem to support the basis of the hypothesis of a negative correlation between mean RSS and standard deviation.

The results also showed that the overall signal strength was improved when the motes were towards the middle of the room's height rather than on floor level. Setup-C, which had the motes elevated by 1.5 m, had significantly improved RSS values compared to Setup-A, as shown by table 7-6 and its -11.1 dB mean variation per position. This suggests that transmitted signals had more directions to travel in and were not directly lost via the floor. Hence, the height of automation control equipment, which is typically placed in or on walls, should be considered during installation. Furthermore, effective antenna design could be used to reduce the amount of signal power wasted in directions, which are not of interest to DfL.

#### 7.4.4 CONCLUSION

The experiment has demonstrated that RSS is not linear to link length in an indoor environment and suggested that signal interactions with walls and objects were the cause. However, it highlighted that mean variation per position remained relatively constant under similar conditions and that motes placed towards mid-height of the room yielded stronger signal connections. Furthermore, the experiment challenged the hypothesis of a negative correlation between mean RSS and standard deviation, which was introduced by section 7.3.

### 7.5 ROOM OCCUPANCY

The indoor environment impacts radio signals, as suggested by the experiments described in section 7.3 and 7.4. Interpreting RSS information for domestic DfL purposes could therefore prove challenging. Section 7.4.3 proposed that an overall signal power assessment, including all radio connections within a room, could be used to identify occupancy. Also, chapter 6 suggested that other areas besides the direct LOS of a communication link might be susceptible to human presence. Hence, two experiments were designed to investigate both of these proposals in the context of room occupancy. The experiments shared the same test environment, but employed different mote layouts.

### 7.5.1 ABSOLUTE SIGNAL POWER

Based on section 7.4's finding that overall mean RSS varied little under similar setup conditions whilst the RSS per individual position varied significantly, this experiment examined whether an absolute signal power approach could be taken to detect human interference on signal patterns within a room. A radio layout similar to that of an automation control system was used for this purpose, as described in 7.5.1.1.

#### 7.5.1.1 METHODOLOGY

Four motes were placed in the corners of a room, which was divided into 25 squares of 0.5 m by 0.5 m. The motes' antennas pointed towards the centre of the room. M0 was positioned on (1,1), M1 on (1,5), M2 on (5,5) and M3 on (5,1). As per definition, M0 was setup as a RX. The other three motes were configured as TXs.

A person stood still in each of the squares, including the ones the motes were placed on, and always faced in the same direction. 100 RSS measurements were recorded per position for  $L_{M1 \rightarrow M0}$ ,  $L_{M2 \rightarrow M0}$  and  $L_{M3 \rightarrow M0}$ . Additionally, values associated with an empty room were taken.

#### 7.5.1.2 RESULTS

With an empty room  $L_{M1 \rightarrow M0}$ ,  $L_{M2 \rightarrow M0}$  and  $L_{M3 \rightarrow M0}$  had mean RSS values of -58.0, -55.0 and -56.7 dBm, and standard deviations of 0.28, 2.11 and 0.67 dBm, respectively.

The mean RSS values with a person present were averaged per position and represented in figure 7-16 along with the positions of each mote. Figures 7-17, 7-18 and 7-19 depict the mean RSS values per position for  $L_{M1 \rightarrow M0}$ ,  $L_{M2 \rightarrow M0}$  and  $L_{M3 \rightarrow M0}$ , individually.

Furthermore, the mean of the three empty room RSS measurements was subtracted from the mean RSS measurements for each position the person stood in and represented in table 7-7. Similarly, tables 7-8, 7-9 and 7-10 show the difference between  $L_{M1 \rightarrow M0}$ 's,  $L_{M2 \rightarrow M0}$ 's and  $L_{M3 \rightarrow M0}$ 's values per occupied position and their corresponding empty room values. The mean variation per position of those four tables was -1.2, 0.2, -3.5 and -0.4 dB, respectively.

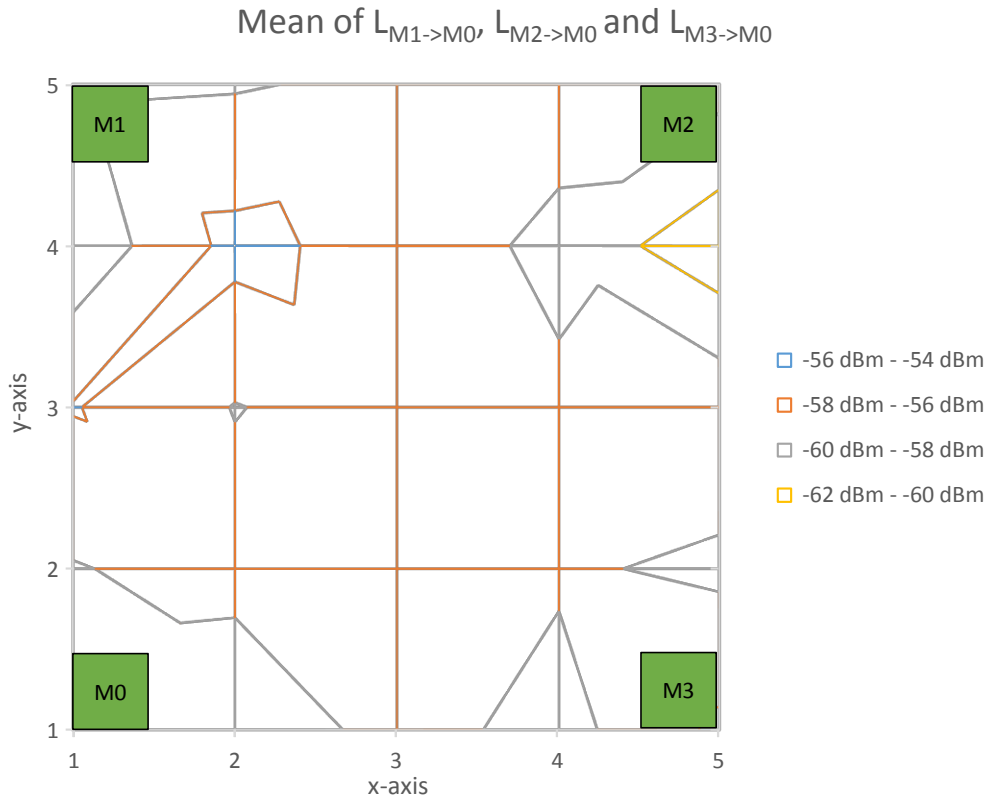

FIGURE 7-16: MEAN RSS PER OCCUPIED POSITION FOR ALL THREE CONNECTIONS

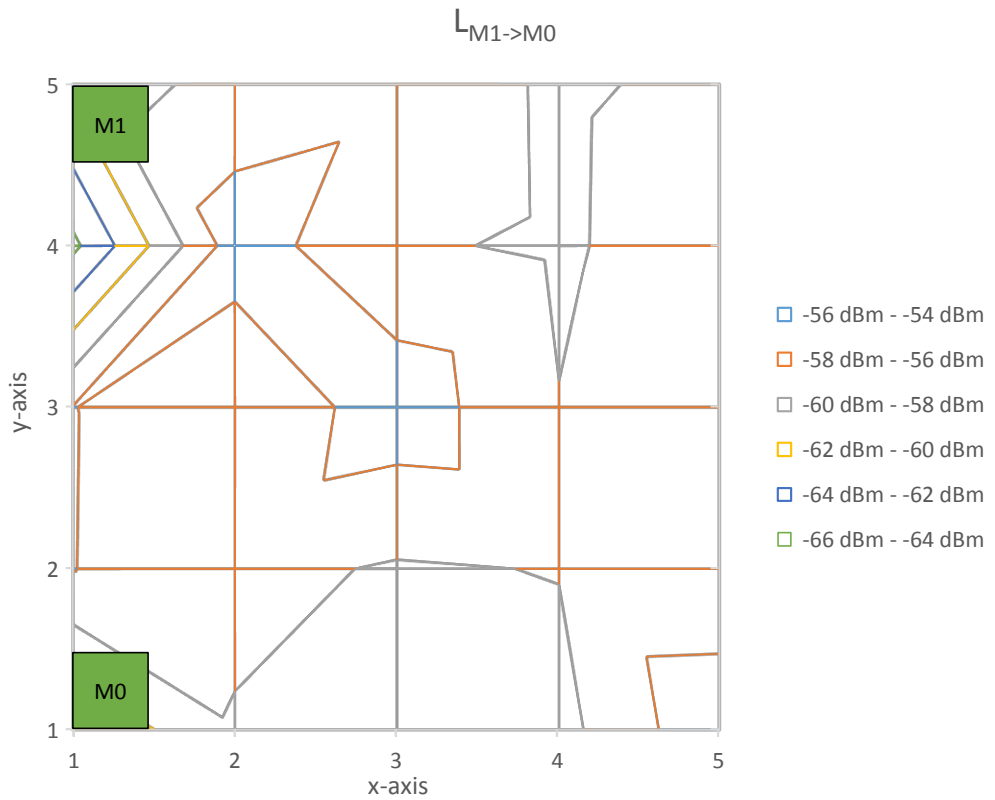

FIGURE 7-17: MEAN RSS PER OCCUPIED POSITION FOR CONNECTION  $L_{M1 \rightarrow M0}$

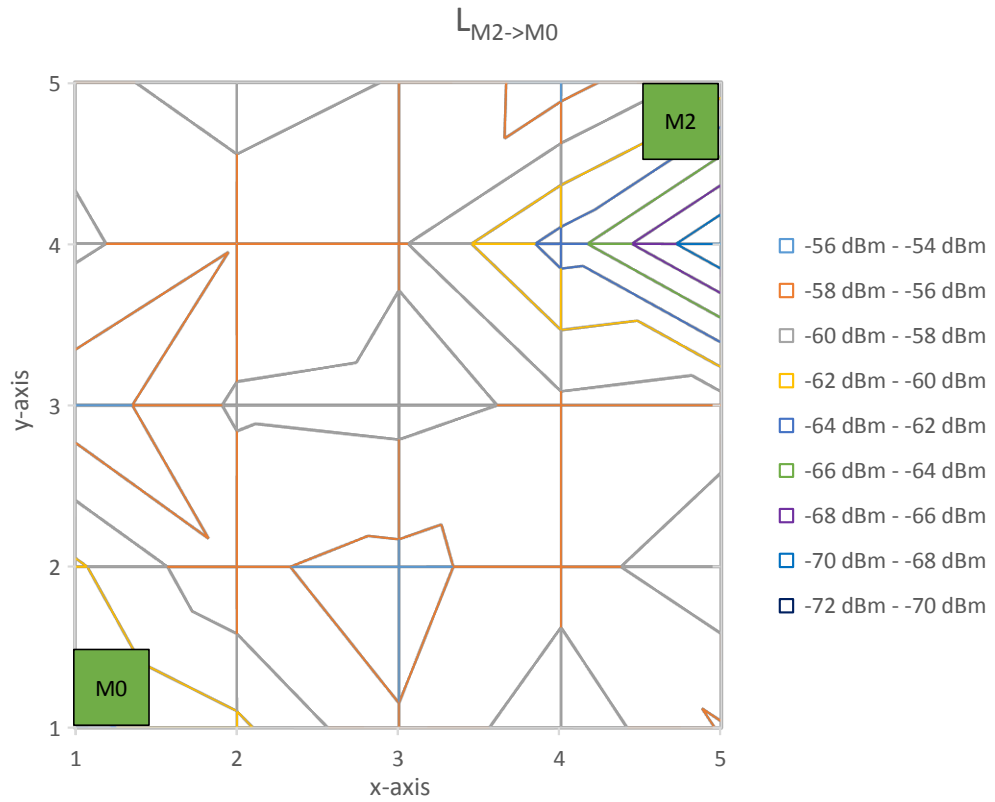

FIGURE 7-18: MEAN RSS PER OCCUPIED POSITION FOR CONNECTION  $L_{M2 \rightarrow M0}$

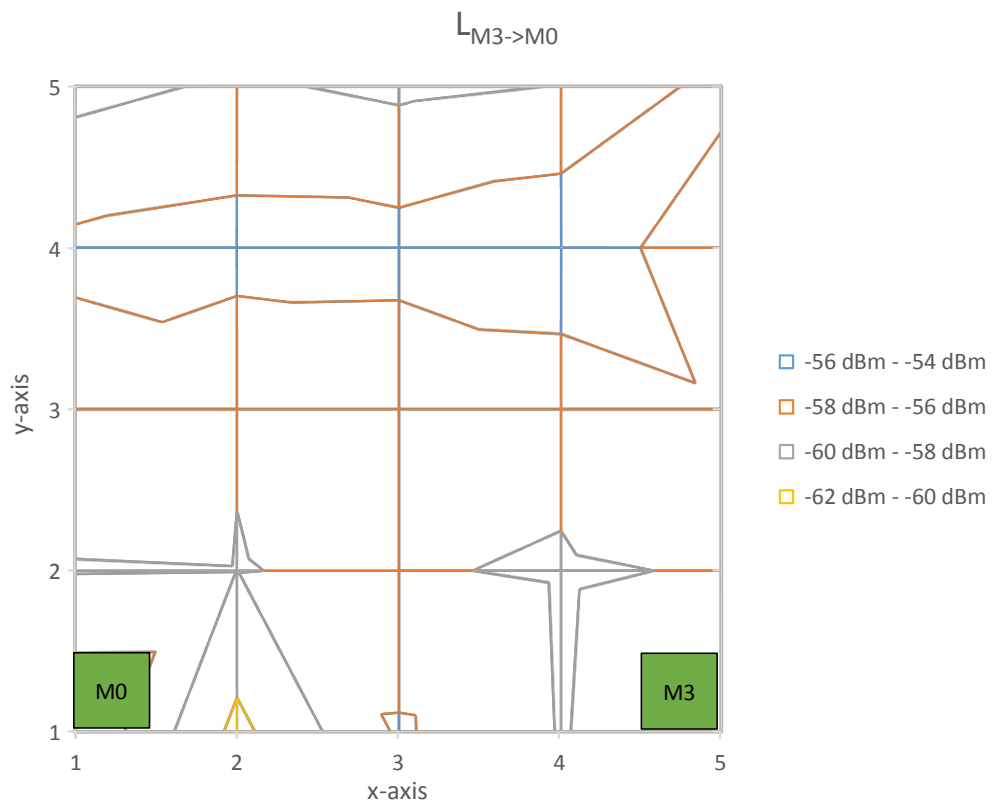

FIGURE 7-19: MEAN RSS PER OCCUPIED POSITION FOR CONNECTION  $L_{M3 \rightarrow M0}$

Overall difference [dB]		X				
due to human presence		1	2	3	4	5
Y	1	-2.9	-3.2	-0.6	-2.2	0.9
	2	-1.6	-0.7	-0.6	-1.2	-1.8
	3	0.7	-1.5	-0.5	-1.1	0.1
	4	-2.9	1.2	-0.3	-1.9	-4.9
	5	-1.8	-1.6	-1.0	-0.6	-0.7

TABLE 7-7: MEAN RSS DIFFERENCE WITH AND WITHOUT HUMAN PRESENCE FOR ALL THREE LINKS

$L_{M1 \rightarrow M0}$ 's difference [dB]		X				
due to human presence		1	2	3	4	5
Y	1	-3.9	-0.2	-1.6	-0.7	3.6
	2	2.0	0.5	-0.2	0.0	0.2
	3	2.0	0.0	3.2	0.0	1.7
	4	-6.5	3.0	0.3	-0.4	1.3
	5	-1.4	0.8	1.4	-0.4	0.5

TABLE 7-8: RSS DIFFERENCE WITH AND WITHOUT HUMAN PRESENCE FOR  $L_{M1 \rightarrow M0}$

$L_{M2 \rightarrow M0}$ 's difference [dB]		X				
due to human presence		1	2	3	4	5
Y	1	-7.5	-5.4	-1.1	-4.5	-0.9
	2	-5.3	-1.3	-0.5	-2.1	-4.5
	3	0.3	-3.3	-3.7	-2.6	-1.9
	4	-3.5	-1.1	-2.7	-7.8	-15.0
	5	-2.1	-4.6	-2.8	-0.1	-4.0

TABLE 7-9: RSS DIFFERENCE WITH AND WITHOUT HUMAN PRESENCE FOR  $L_{M2 \rightarrow M0}$

$L_{M3 \rightarrow M0}$ 's difference [dB]		X				
due to human presence		1	2	3	4	5
Y	1	2.7	-3.8	1.0	-1.4	0.1
	2	-1.4	-1.3	-1.1	-1.5	-1.2
	3	-0.3	-1.2	-0.9	-0.7	0.4
	4	1.2	1.6	1.5	2.4	-1.0
	5	-1.9	-1.0	-1.7	-1.2	1.4

TABLE 7-10: RSS DIFFERENCE WITH AND WITHOUT HUMAN PRESENCE FOR  $L_{M3 \rightarrow M0}$

### 7.5.1.3 DISCUSSION

The relationship between LOS obstruction and signal strength drop was not as clearly apparent during this test as it was during the experiments described in chapter 6. Figures 7-17 to 7-19 did not seem to depict consistent patterns. In fact, some positions taken by the person on the links' LOS even yielded increased RSS values, as tables 7-8 and 7-10 show. The indoor environment, which significantly influences signal distribution patterns as demonstrated in section 7.4, might have been responsible for this non-uniformity.

However, on average the RSS of the three links decreased mainly with a person standing near a TX or RX and close to a wall, as highlighted by figure 7-16. This is somewhat consistent with the findings of section 6.5 and suggests, according to Wilson and Patwari [126], that reflection was the dominant signal interaction mechanism with the human body.

Also, the mean variation per position due to human presence, in other words, the mean value of table 7-7, was relatively small with -1.2 dB. In real terms, it might have been even closer to zero as the empty room value for  $L_{M2 \rightarrow M0}$ , which was with -55 dBm the highest of the three, showed an elevated standard deviation during recording, as mentioned in 7.5.1.2. This elevated empty room value also caused the relatively significant mean variation of -3.5 dB for table 7-9. Conclusively, a small mean variation in absolute signal power would support the previous suggestion that the dominant signal interaction with the human body was not absorption, but reflection or diffusion.

### 7.5.2 SPATIAL RELATION

Chapter 6 demonstrated in two separate experiments involving once a mobile and once an immobile person that the impact on RSS depended on the spatial relation between communication link and human interference, and not purely on the obstruction of the direct LOS. A test was designed to investigate this relation in the setting of a domestic room environment.

Additionally, the experiment described in section 7.5.1, which shared the same test environment, suggested that reflection was the dominant signal propagation method caused by human interference. Hence, the following experiment also examined

scenarios which varied the reflective effects of a person, by letting them stand still or move.

#### 7.5.2.1 METHODOLOGY

Three motes were placed in the room described in section 7.5.1.1. M1 and M2 were positioned in centre of (3,4) and (3,2), respectively. Their antennas faced away from each other. M0 was placed at the outer edge of (1,3) and plugged into a USB extension, which permitted its y-axis, as shown in figure 7-2, to be parallel to the room's z-axis, thus letting the antenna point upwards and the battery side face the nearest wall.

M1 and M2 were configured as transceivers. They sent packets to each other and once they received that of the other one, they forwarded the associated RSS to M0.

As in the experiment mentioned in section 7.5.1, a person stood in each of the squares facing in the same direction. In addition to standing still, the scenario of a person running on the spot was assessed.

100 RSS measurements were recorded per position for  $L_{M1 \rightarrow M2}$ ,  $L_{M2 \rightarrow M1}$ ,  $L_{M1 \rightarrow M0}$  and  $L_{M2 \rightarrow M0}$ . Furthermore, values associated with an empty room were taken for each link.

#### 7.5.2.2 RESULTS

The mean RSS values measured with an empty room were -39.0, -38.7, -58.2 and -66.2 dBm for  $L_{M1 \rightarrow M2}$ ,  $L_{M2 \rightarrow M1}$ ,  $L_{M1 \rightarrow M0}$  and  $L_{M2 \rightarrow M0}$ , respectively.

Figures 7-20 to 7-23 represent the mean RSS measurements for all four links during the test with an immobile person in each position, and figures 7-24 to 7-27 show those with a mobile person. The mean RSS per link were -40.0, -39.3, -57.7 and -63.1 dBm for the immobile test and -42.0, -41.4, -63.9 and -60.8 dBm for the mobile test for  $L_{M1 \rightarrow M2}$ ,  $L_{M2 \rightarrow M1}$ ,  $L_{M1 \rightarrow M0}$  and  $L_{M2 \rightarrow M0}$ , respectively.

The differences between the mean RSS values per position of both, the immobile and mobile test, were represented in tables 7-11 to 7-14 for all four connections. The overall means were 2.0, 2.1, 6.3 and -2.3 dB for  $L_{M1 \rightarrow M2}$ ,  $L_{M2 \rightarrow M1}$ ,  $L_{M1 \rightarrow M0}$  and  $L_{M2 \rightarrow M0}$ , respectively.

$L_{M1 \rightarrow M2}$  and  $L_{M2 \rightarrow M1}$  had a mean RSS correlation coefficient of 0.98 for the immobile test and a 0.99 coefficient for the mobile test.



Furthermore, it was noticed that for both scenarios,  $L_{M2 \rightarrow M1}$  had on average 0.7 dB stronger RSS values per position than  $L_{M1 \rightarrow M2}$ .

Also,  $L_{M1 \rightarrow M2}$ 's immobile and mobile tests correlated with a coefficient of 0.84; similarly  $L_{M2 \rightarrow M1}$ 's correlation coefficients was 0.81.  $L_{M1 \rightarrow M0}$  and  $L_{M2 \rightarrow M0}$  on the other hand, did not produce any significant correlations.

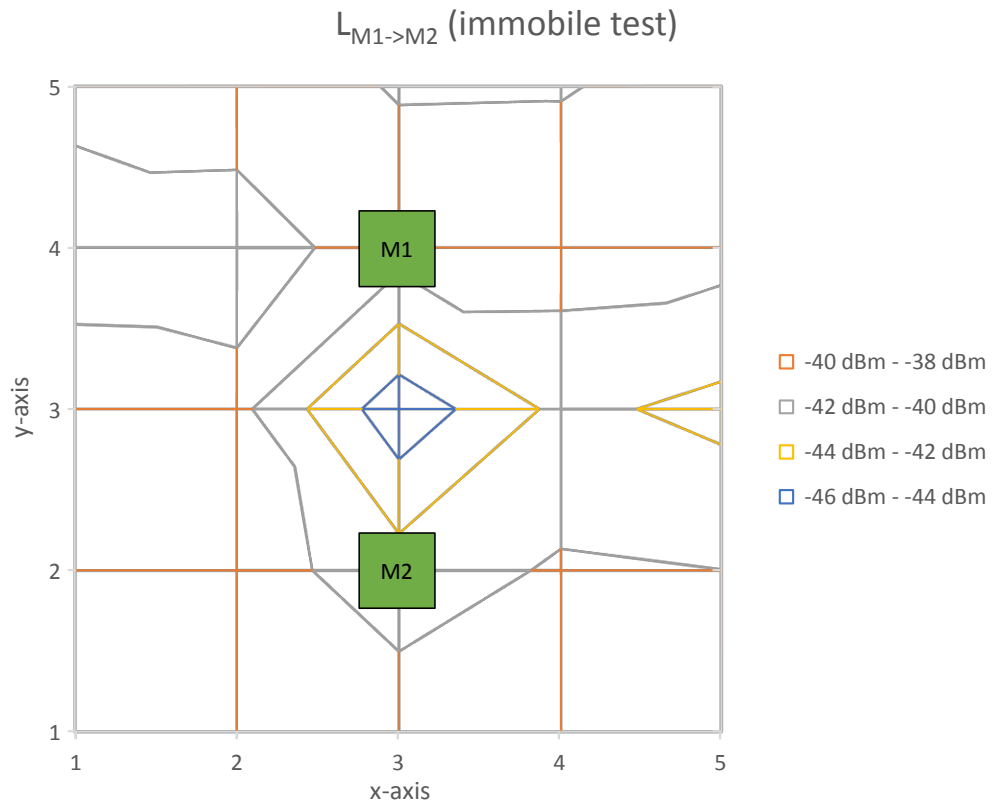

FIGURE 7-20: RSS FOR EACH POSITION A PERSON STOOD IN FOR CONNECTION  $L_{M1 \rightarrow M2}$

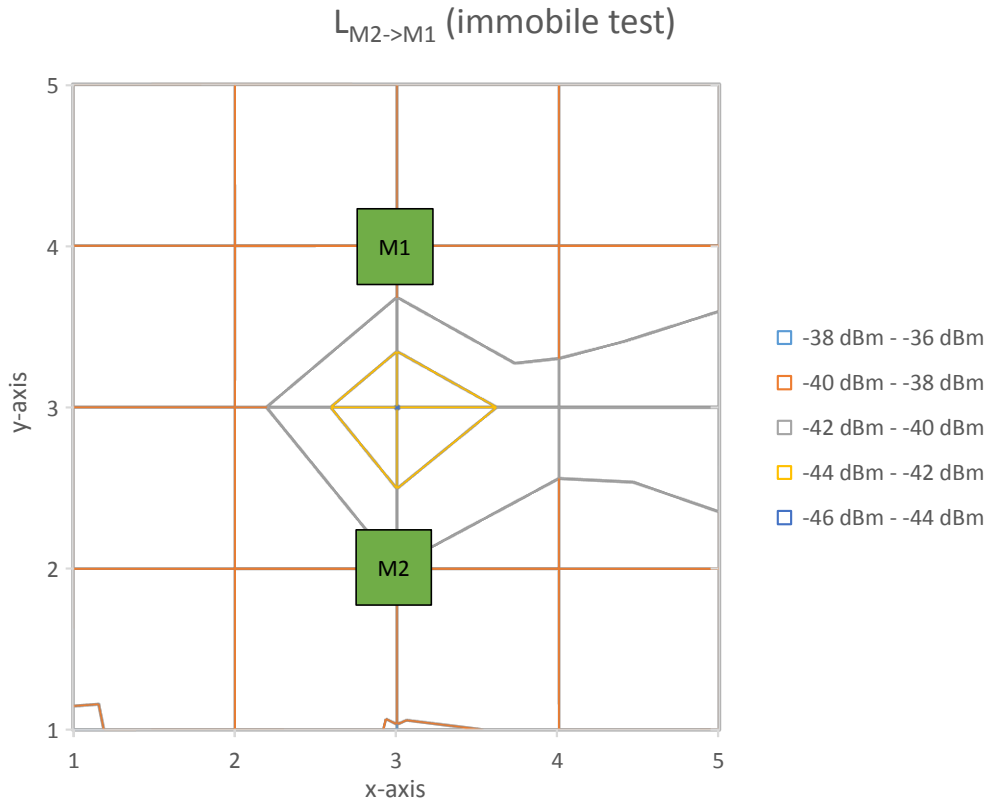

FIGURE 7-21: RSS FOR EACH POSITION A PERSON STOOD IN FOR CONNECTION  $L_{M2 \rightarrow M1}$

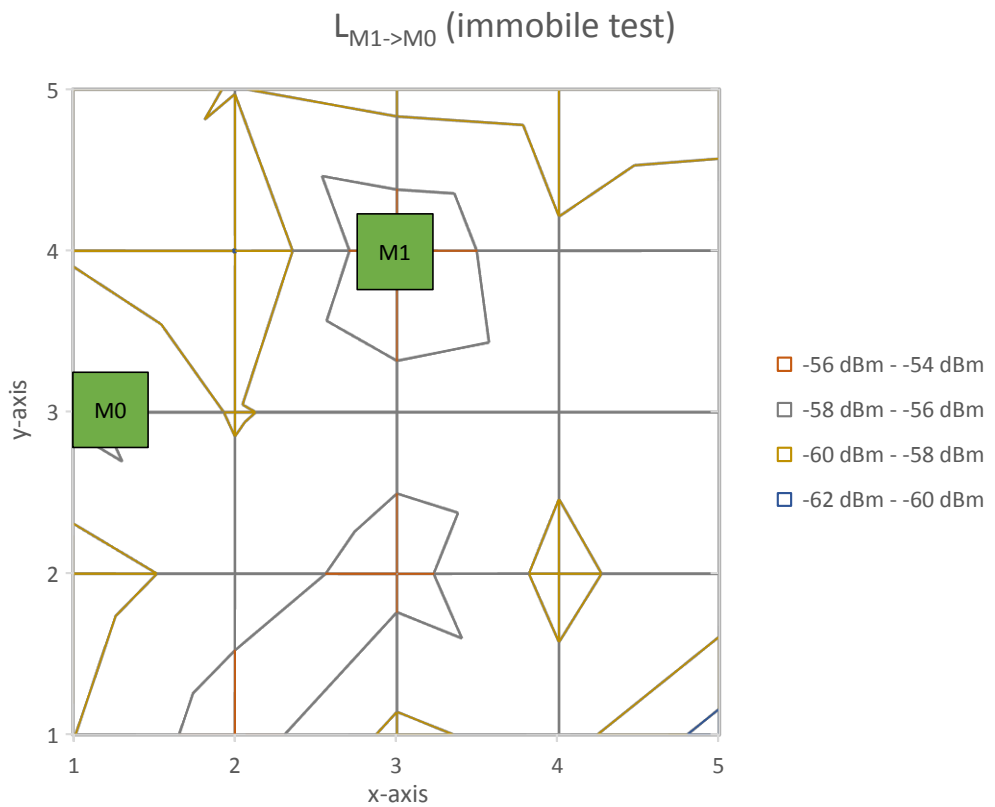

FIGURE 7-22: RSS FOR EACH POSITION A PERSON STOOD IN FOR CONNECTION  $L_{M1 \rightarrow M0}$

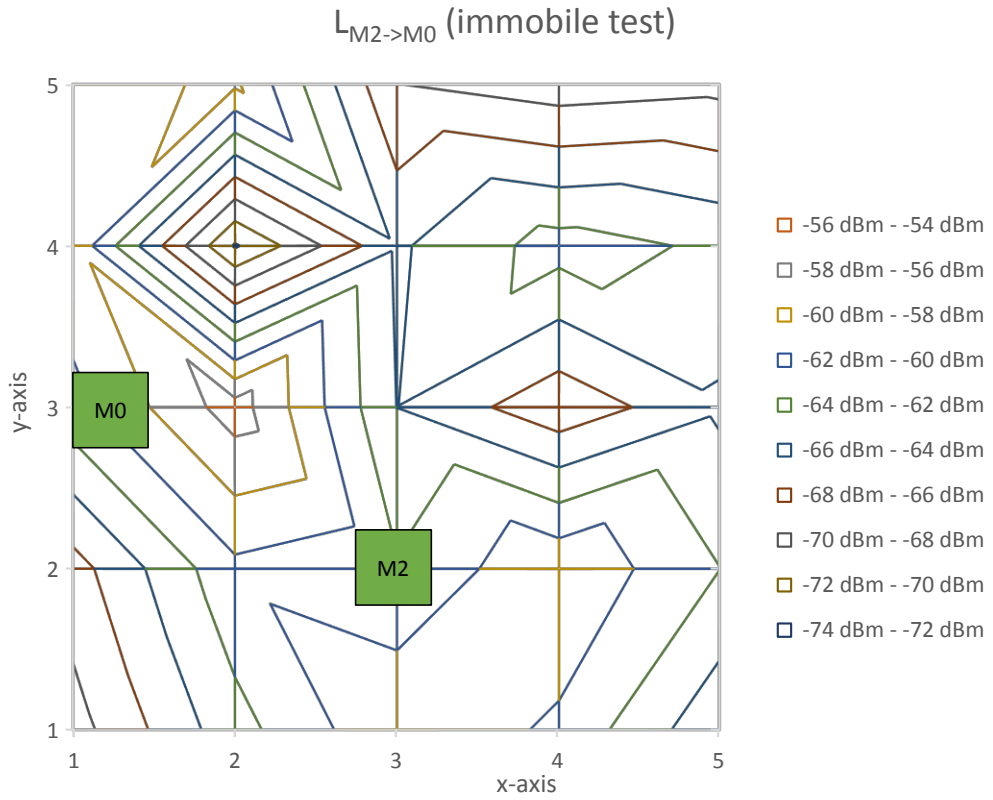

FIGURE 7-23: RSS FOR EACH POSITION A PERSON STOOD IN FOR CONNECTION  $L_{M2 \rightarrow M0}$

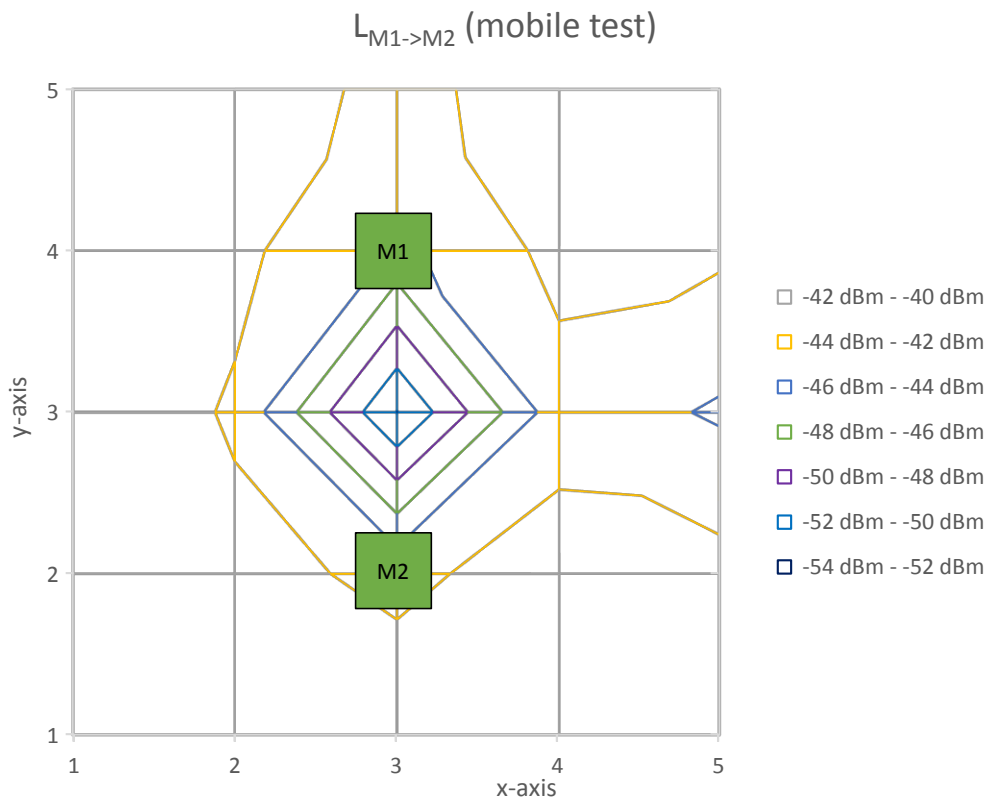

FIGURE 7-24: RSS FOR EACH POSITION A PERSON MOVED IN FOR CONNECTION  $L_{M1 \rightarrow M2}$

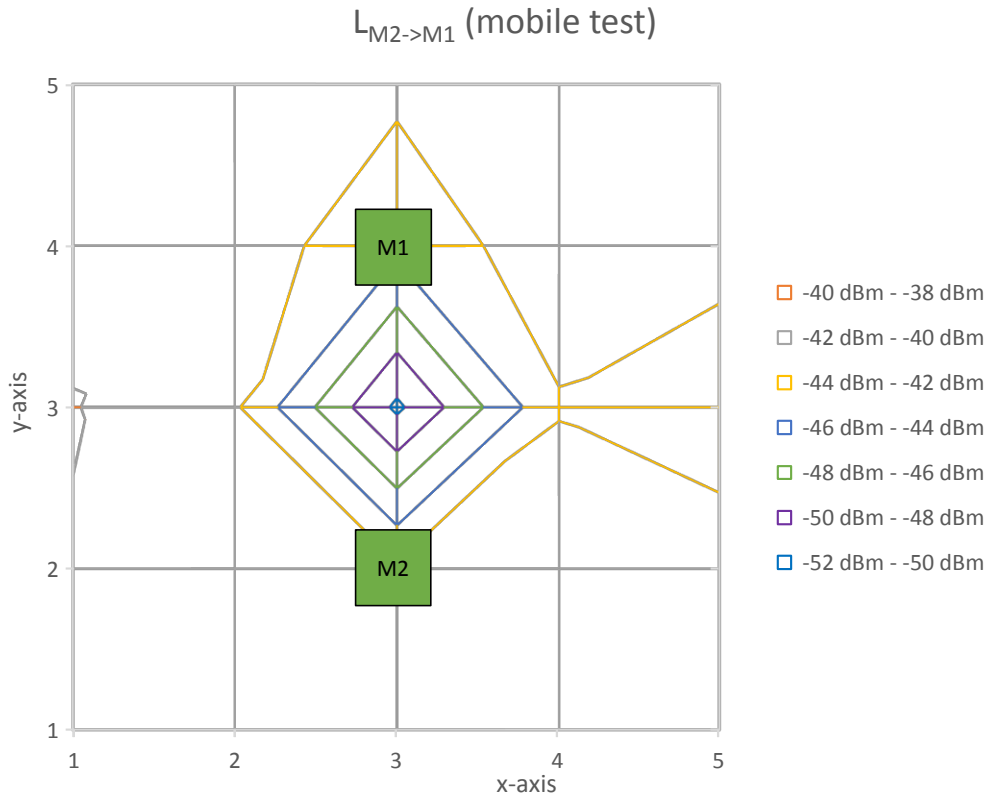

FIGURE 7-25: RSS FOR EACH POSITION A PERSON MOVED IN FOR CONNECTION  $L_{M2 \rightarrow M1}$

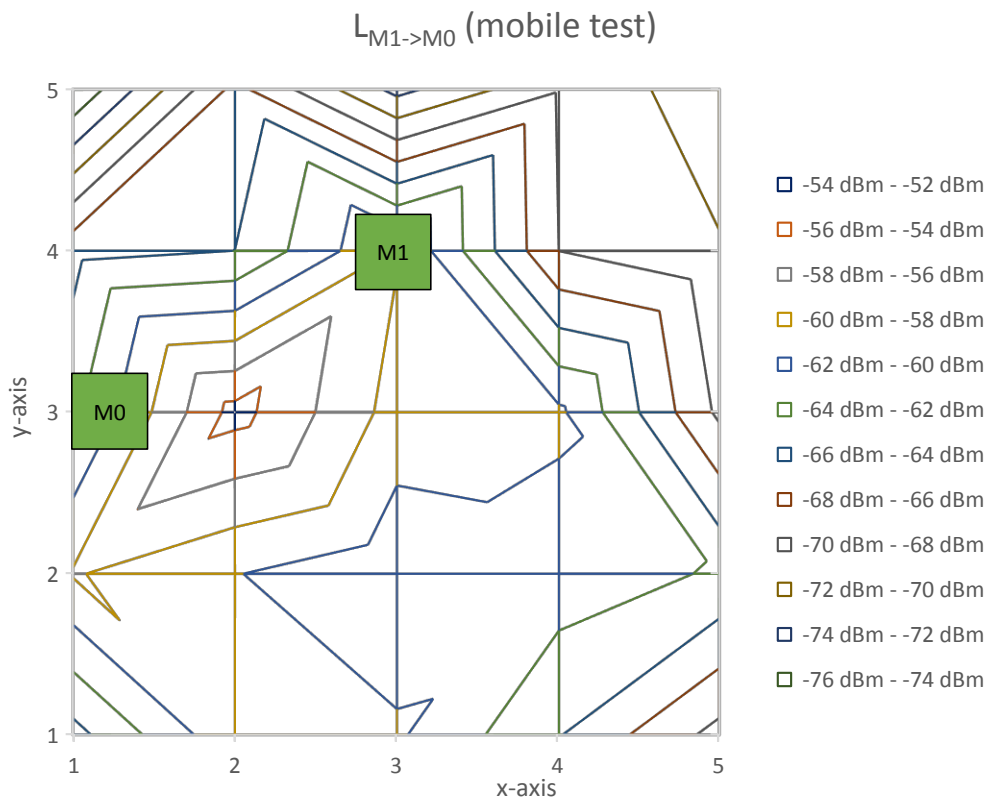

FIGURE 7-26: RSS FOR EACH POSITION A PERSON MOVED IN FOR CONNECTION  $L_{M1 \rightarrow M0}$

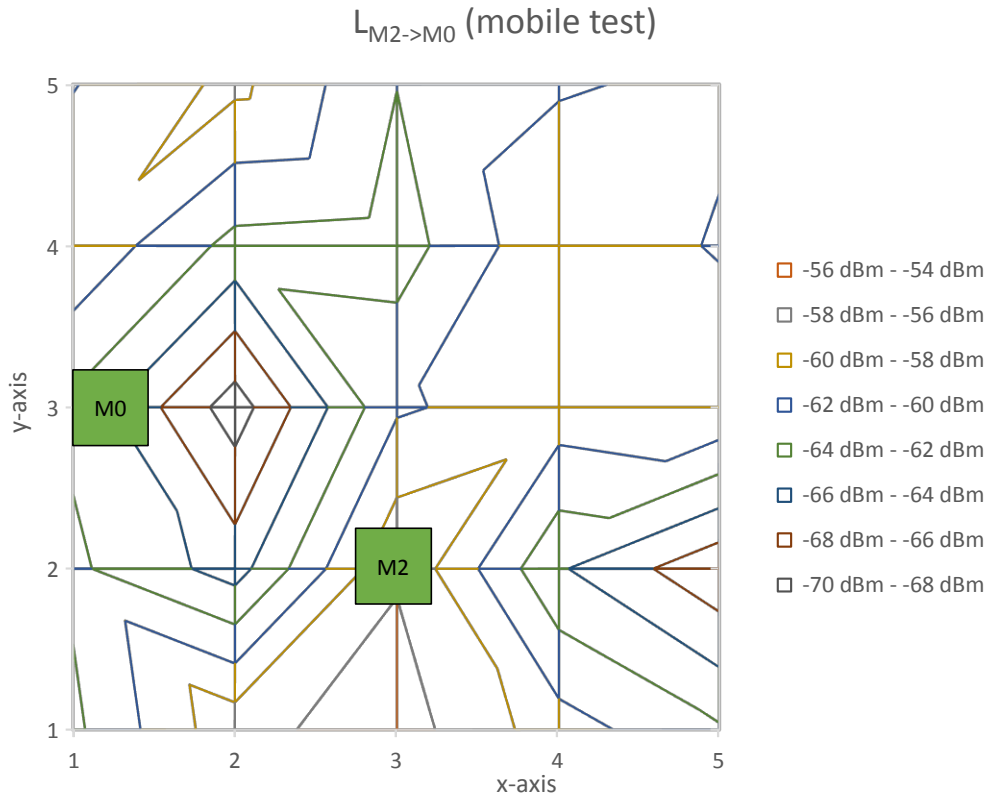

FIGURE 7-27: RSS FOR EACH POSITION A PERSON MOVED IN FOR CONNECTION  $L_{M2 \rightarrow M0}$

$L_{M1 \rightarrow M2}$ 's immobile –		X				
mobile difference [dB]		1	2	3	4	5
Y	1	2.0	2.1	2.0	1.9	1.9
	2	1.5	2.3	1.4	1.4	1.3
	3	1.1	2.8	6.7	1.3	1.7
	4	0.3	0.5	5.5	2.4	2.4
	5	1.7	2.1	2.3	1.2	1.6

TABLE 7-11: DIFFERENCE BETWEEN IMMOBILE AND MOBILE RSS VALUES FOR  $L_{M1 \rightarrow M2}$

$L_{M2 \rightarrow M1}$ 's immobile –		X				
mobile difference [dB]		1	2	3	4	5
Y	1	2.9	2.1	2.6	2.2	1.2
	2	1.1	2.1	1.7	1.1	1.6
	3	1.3	2.7	6.3	1.5	1.9
	4	0.8	1.1	5.3	2.5	2.3
	5	2.0	2.4	2.0	1.2	1.0

TABLE 7-12: DIFFERENCE BETWEEN IMMOBILE AND MOBILE RSS VALUES FOR  $L_{M2 \rightarrow M1}$

$L_{M1 \rightarrow M0}$ 's immobile – mobile difference [dB]		X				
		1	2	3	4	5
Y	1	6.7	3.5	1.3	6.7	8.0
	2	-1.3	2.9	6.2	2.3	5.9
	3	6.9	-4.9	2.0	2.3	10.8
	4	6.4	4.0	3.5	10.3	13.0
	5	17.2	7.4	13.9	9.2	12.5

TABLE 7-13: DIFFERENCE BETWEEN IMMOBILE AND MOBILE RSS VALUES FOR  $L_{M1 \rightarrow M0}$

$L_{M2 \rightarrow M0}$ 's immobile – mobile difference [dB]		X				
		1	2	3	4	5
Y	1	-6.4	-6.2	-3.2	-1.3	-3.8
	2	-5.2	4.4	-5.6	5.5	5.6
	3	1.7	14.0	-3.8	-8.6	-6.2
	4	0.0	-9.6	-1.4	-2.9	-2.1
	5	1.3	-0.1	-6.0	-8.8	-9.0

TABLE 7-14: DIFFERENCE BETWEEN IMMOBILE AND MOBILE RSS VALUES FOR  $L_{M2 \rightarrow M0}$

### 7.5.2.3 DISCUSSION

Connections  $L_{M1 \rightarrow M2}$  and  $L_{M2 \rightarrow M1}$  confirmed the relation between LOS obstruction and decreased RSS, as shown in figures 7-20, 7-21, 7-24 and 7-25. However, other positions outside the LOS also had this effect on those links' RSS, such as position (5,3) for example, which could suggest that the person obstructed or created multipath signals.

Connections  $L_{M1 \rightarrow M0}$  and  $L_{M2 \rightarrow M0}$ , which did not have a position that corresponded to their direct LOS, showed very non-uniform RSS response patterns. Positions just next to the LOS yielded RSS increases or decreases due to human presence, as demonstrated by positions (2,3) and (2,4) for link  $L_{M1 \rightarrow M0}$  in figure 7-26. Some measurements also confirmed the findings of section 6.5 that human presence behind radio connections can improve RSS.

Furthermore, the correlation between  $L_{M1 \rightarrow M2}$  and  $L_{M2 \rightarrow M1}$  was very significant for both, mobile and immobile tests with coefficients of 0.99 and 0.98 respectively, which supports the link symmetry findings of section 7.3.2. On the other hand,  $L_{M2 \rightarrow M1}$  had consistently stronger RSS than  $L_{M1 \rightarrow M2}$ ; and despite symmetrical mote layout,

identical rather than mirrored RSS responses were recorded by both links. In other words, as for example position (3,5) yielded a decrease in RSS for connection  $L_{M1 \rightarrow M2}$ , shown in figure 7-24, it was expected that position (3,1) would do the same for  $L_{M2 \rightarrow M1}$  in figure 7-25. This could indicate that the correlation between  $L_{M1 \rightarrow M2}$  and  $L_{M2 \rightarrow M1}$  was not a product of the motes' antennas' link symmetries, but of the effects of the indoor environment. Lymberopoulos et al. [100], who studied CC2420 radio chips, suggested that link symmetry only applies to limited regions of antenna orientation and that indoor environments alter this symmetry due to multipath and fading effects. The fact that the correlation between different links had greater coefficients than the correlation between the mobile and immobile tests for the same link, also seem to support this suggestion.

The combined means of tables 7-11 to 7-14 showed that the overall signal strength was weakened more by a moving than a standing person. Also, the difference between the mean RSS per link and the empty room measurements showed a range of -1.0 to 3.1 dB for the immobile test and a range of -5.7 to 5.4 dB for the mobile test, which suggests that running on the spot created more multipath signals than standing still. Hence, these findings support those of section 7.5.1 that signal reflections or diffusions cause the RSS variations required for indoor DfL.

### 7.5.3 CONCLUSION

The experiments described in section 7.5.1 and 7.5.2 demonstrated the relation between indoor environment and occupancy with regards to DfL. An absolute power assessment suggested that reflection and diffusion, caused by the human body, were more dominant indicators than signal absorption, which was further supported by the fact that running on the spot showed larger impacts on RSS than standing still.

Consequently, the positions of the radios in relation to the room impacted the RSS responses. In section 7.5.1's experiment, the motes were placed in the corners of the room and primarily responded to human presence close to either the TX or RX. In section 7.5.2's experiment on the other hand, two of the motes were positioned in the centre of the room and showed significant RSS decreases with human presence in the direct LOS. Also, RSS

responses to human presence outside the direct LOS were shown and linked to the impact of the indoor environment.

Furthermore, the experiments questioned whether a large correlation coefficient was a sign for link symmetry or environment induced.

## 7.6 CHAPTER CONCLUSION

Part A of the comprehensive DfL study investigated the antenna pattern of TelosB motes, and demonstrated a link symmetry between transmitting and receiving antenna patterns, which was later questioned by a subsequent experiment. A negative correlation between mean RSS and its standard deviation was also suggested, which was then applied to and disproven by the indoor signal propagation experiment. Additionally, the latter demonstrated that the signal patterns within an empty room were non-uniform due to multipath propagations, and that signal strength can be improved by placing radios towards mid-height. Furthermore, it was suggested that an absolute power analysis, involving several communication links within a room, might help identify occupancy. However, a dedicated study found that reflection and diffusion by the human body caused RSS decreases rather than signal absorption, which suggests that variations rather than absolute power levels should be employed for DfL purposes. In addition, it was demonstrated, as those findings would imply, that a moving person had a larger impact on RSS than an immobile one, and that the positions of the radios within a room varied the RSS response patterns to human presence.

In contrast, the study also implied that the significant influence of the indoor environment obscured the clarity of the data and thus hindered interpretation, as shown by the inconclusive findings of the antenna assessment experiment. Hence, to research and understand DfL capabilities outdoor experiments are required, which were conducted in part B of the comprehensive study, described in chapter 8.



## **8 DFL – COMPREHENSIVE STUDY – PART B**

### **8.1 INTRODUCTION**

Part A of the comprehensive study, described in chapter 7, examined the relation between indoor environment and DfL, with experiments using two to four radios. It suggested that the substantial interference by indoor multipath signals hindered data analysis. Hence, part B of the comprehensive study employed outdoor experiments, which were designed to analyse DfL network layout and confirm the requirements set out by COAC systems, described in section 3.4.2. With COAC systems likely to require more than four radios, distribution tests investigating the density and quantity of radio deployment in relation to DfL were conducted. Also, the abilities to localise one or several people, as well as track them, were assessed.

### **8.2 DENSITY**

The experiments undertaken in chapter 7 used between two and four TelsoB motes, described in section 7.2, with relatively simplistic layouts. However, those experiments were aimed at room level occupancy. In the context of dwelling applied COAC systems a larger amount of radios is required, which increases the number of possible layouts. Hence, this section assessed the relationship between the density of mote deployment and RSS variations caused by human presence.

#### **8.2.1 METHODOLOGY**

Seventeen motes were placed on wooden blocks on a grass surface. M0 was positioned in the middle of three different mote layouts, called Layout-A, Layout-B and Layout-C, as depicted in figures 8-1, 8-2 and 8-3, respectively. The divisions on the x- and y-axis in each of those figures correspond to 0.5 m, i.e. Layout-A covered an area of 4 m<sup>2</sup>, Layout-B 16 m<sup>2</sup> and Layout-C 24 m<sup>2</sup>.

Also, as the antenna assessment of TelosB motes described in section 7.3 was inconclusive, M0 was positioned in two different ways in each of the layouts. The first setup made M0's x-axis, as shown in figure 7-2, point towards M1 and its y-axis towards the sky. For the second setup, M0's x-axis pointed towards the sky and its y-axis towards M2. Hence, the six setups tested were A1, A2, B1, B2, C1 and C2.

As per definition, which was outlined in section 7.2, M0 was programmed as a RX. The remaining motes were setup as TXs and their x-axes pointed towards the sky whilst their y-axes pointed towards M0. All packets were transmitted simultaneously.

For each of the setups 100 RSS values were measured, once with someone standing in the LOS between M0 and M1, i.e. position (8,6), as shown in figures 8-1 to 8-3; and once without anybody present.

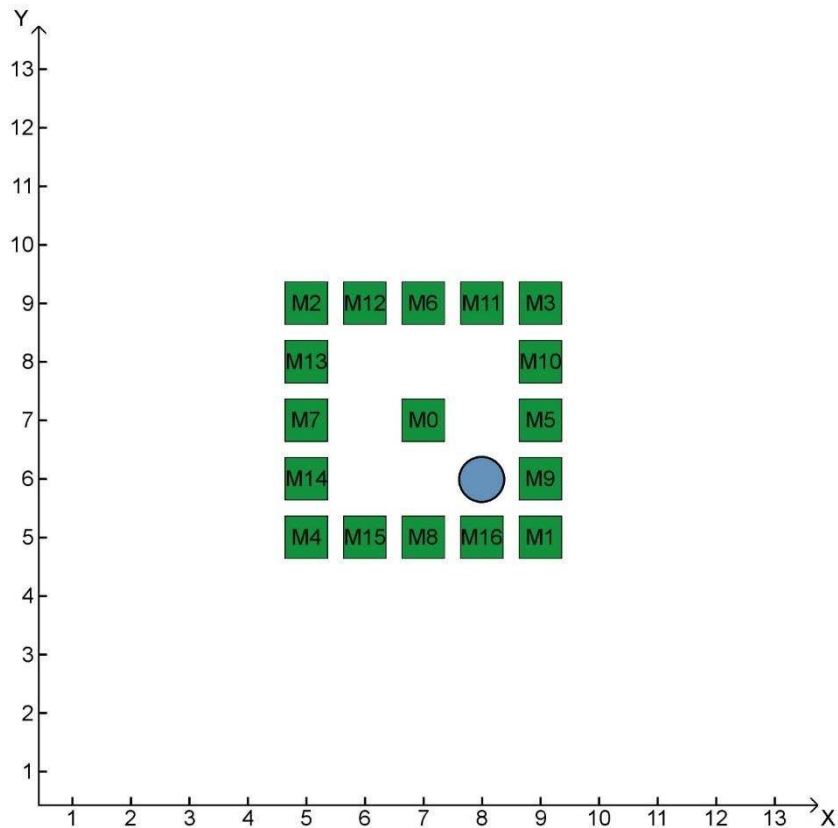

FIGURE 8-1: POSITIONS OF MOTES AND A PERSON IN LAYOUT-A

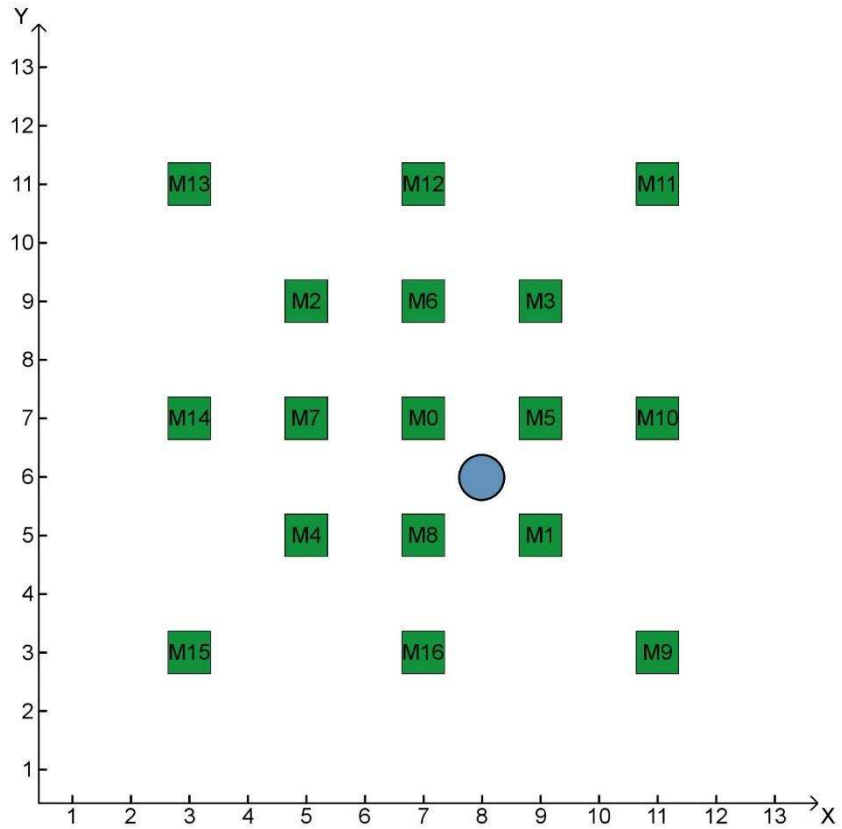

FIGURE 8-2: POSITIONS OF MOTES AND A PERSON IN LAYOUT-B

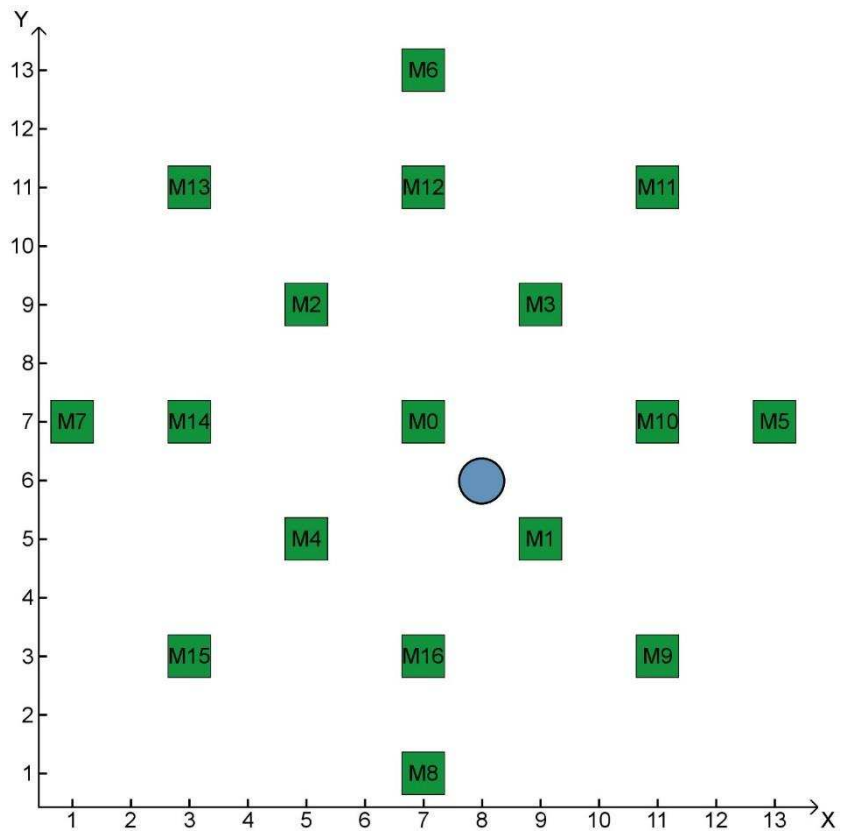

FIGURE 8-3: POSITIONS OF MOTES AND A PERSON IN LAYOUT-C

8.2.2 RESULTS

The mean RSS values per mote for the six different setups and for the empty and present scenarios were represented in figure 8-4.

For setups A1 to C2, figures 8-5 to 8-10 show the variations due to human presence for each individual mote.

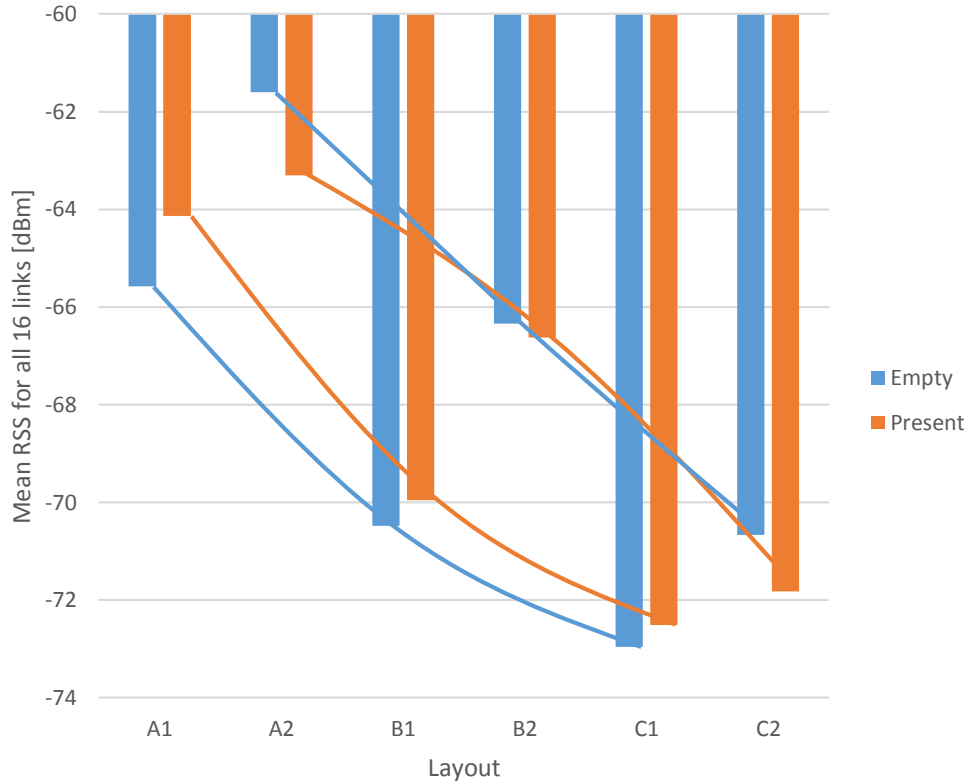

FIGURE 8-4: MEAN RSS FOR ALL 16 LINKS, FOR ALL SIX SETUPS AND FOR HUMAN ABSENCE AND PRESENCE

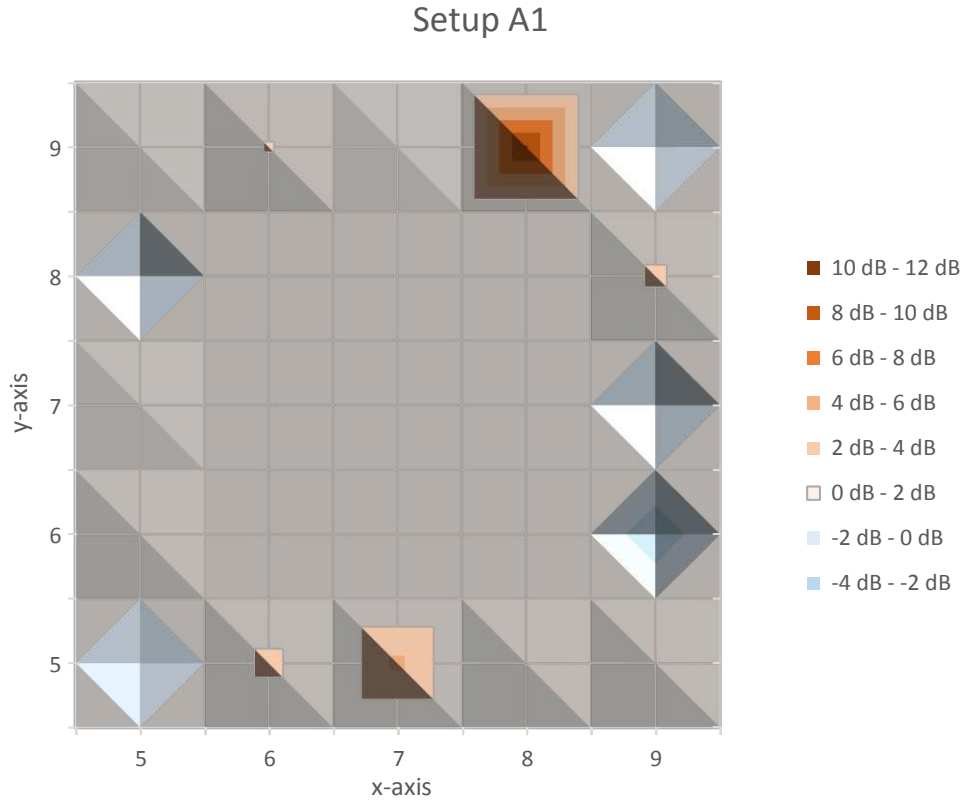

FIGURE 8-5: DIFFERENCE BETWEEN PRESENT AND EMPTY RSS VALUES FOR SETUP A1

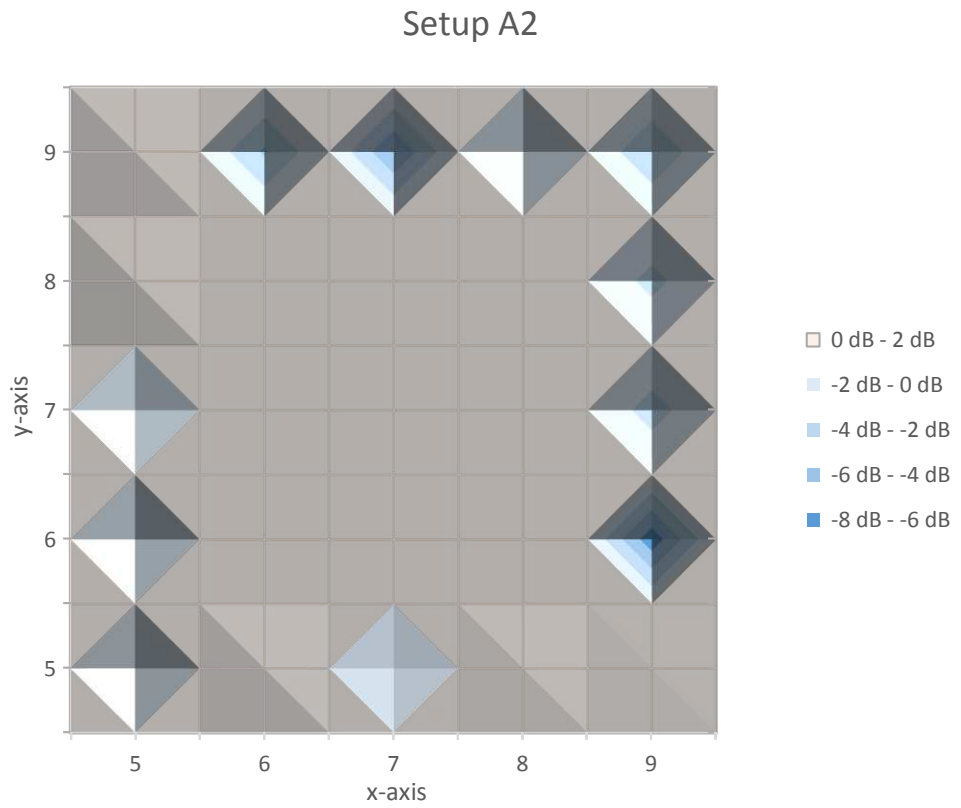

FIGURE 8-6: DIFFERENCE BETWEEN PRESENT AND EMPTY RSS VALUES FOR SETUP A2

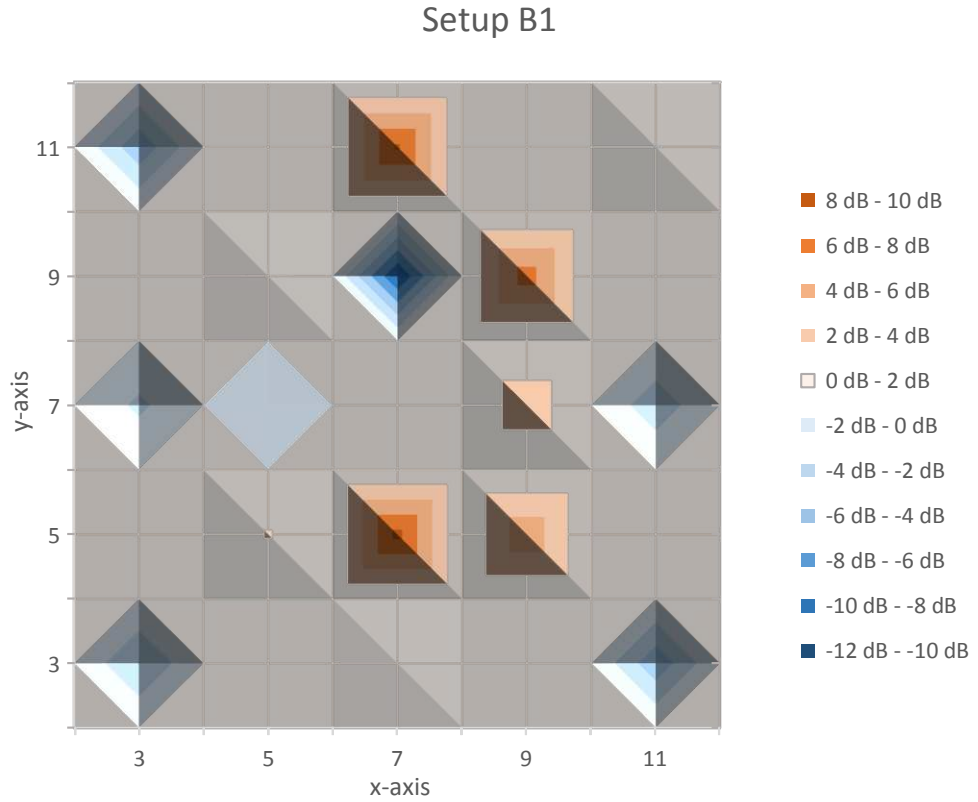

FIGURE 8-7: DIFFERENCE BETWEEN PRESENT AND EMPTY RSS VALUES FOR SETUP B1

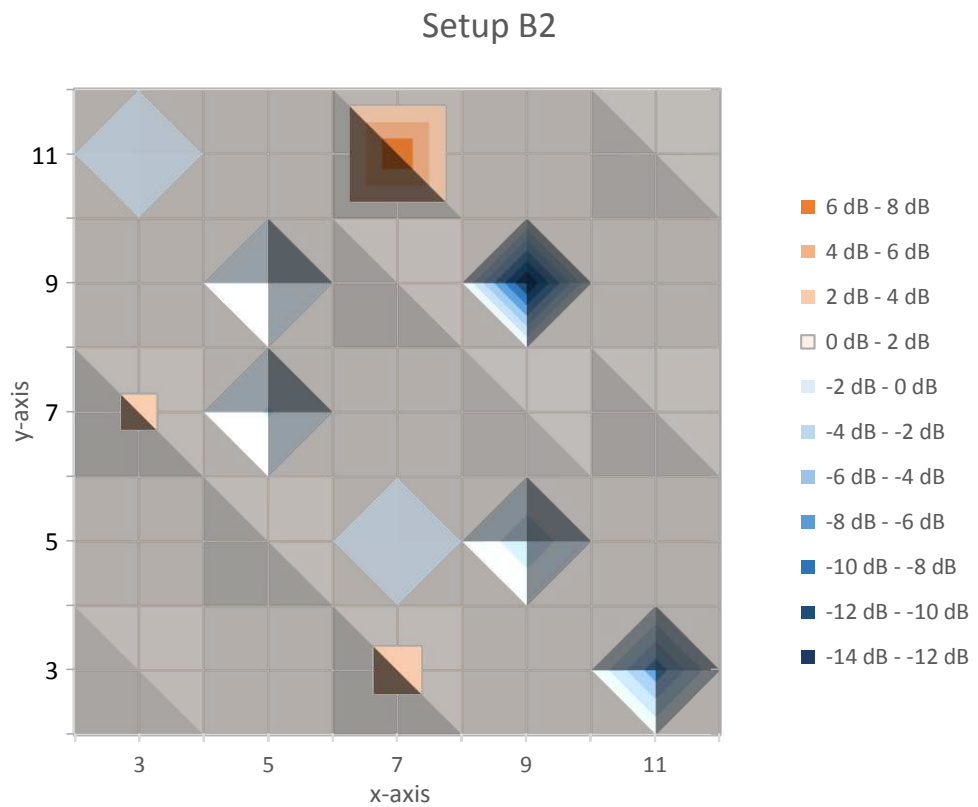

FIGURE 8-8: DIFFERENCE BETWEEN PRESENT AND EMPTY RSS VALUES FOR SETUP B2

Setup C1

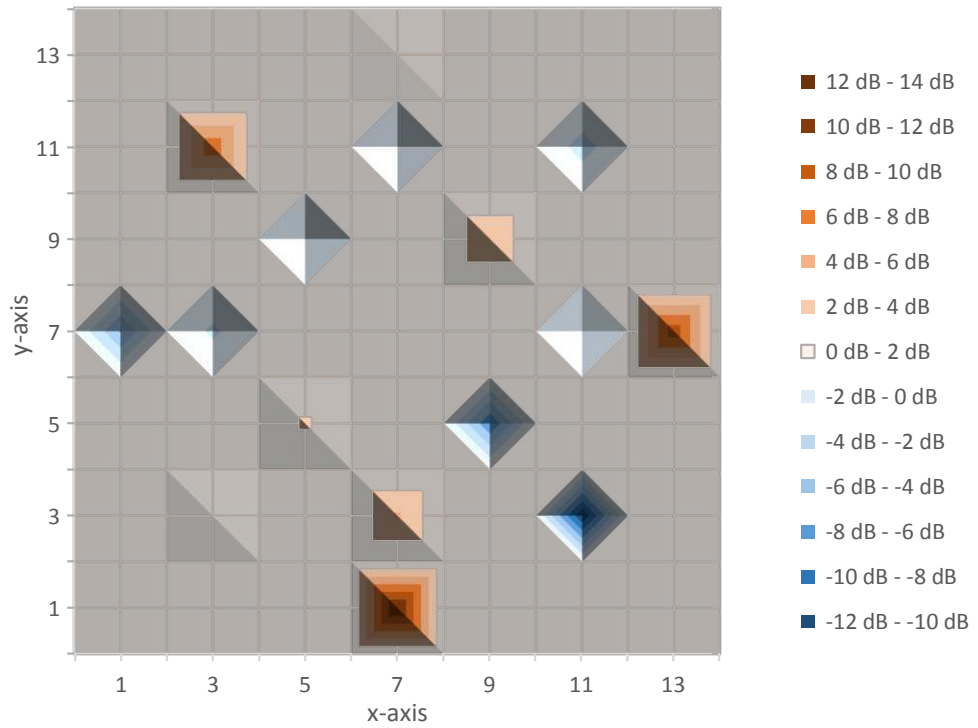

FIGURE 8-9: DIFFERENCE BETWEEN PRESENT AND EMPTY RSS VALUES FOR SETUP C1

Setup C2

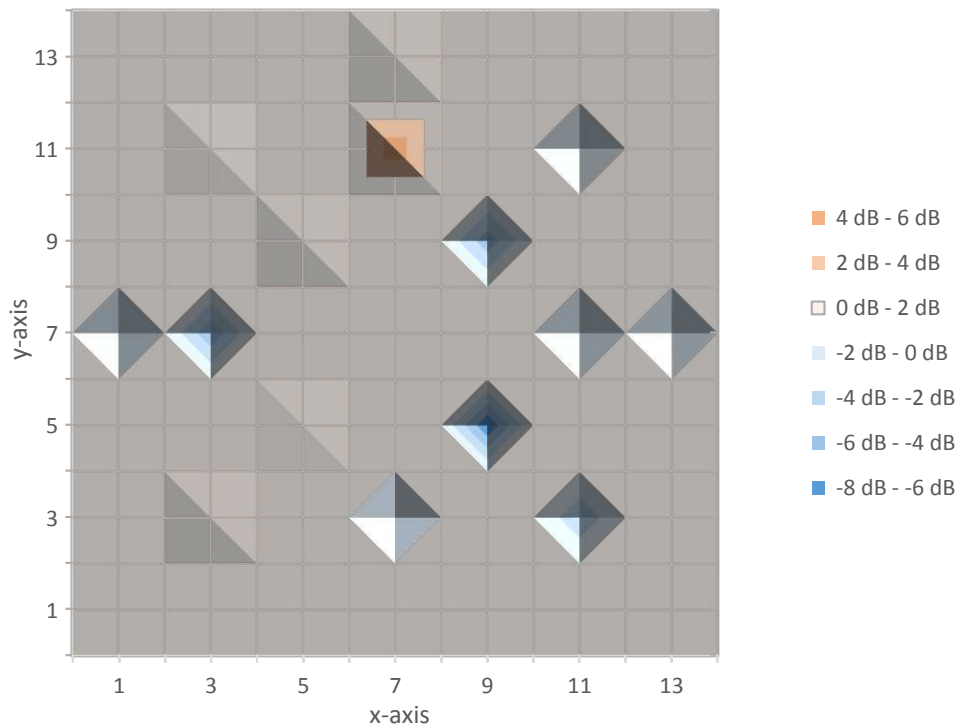

FIGURE 8-10: DIFFERENCE BETWEEN PRESENT AND EMPTY RSS VALUES FOR SETUP C2

### 8.2.3 DISCUSSION

The results suggested that the mean RSS per mote decreased with decreasing mote density. As highlighted by the lines in figure 8-4, the setups sharing the same occupancy status and the same antenna setup had the lowest RSS values for the least dense Layout-C and the strongest RSS values for the densest Layout-A. The signal fading effect, described by equation 5-1, could be responsible.

Also, the differences between the lines shown in figure 8-4, with exception of B2, seem to suggest that the overall RSS response to human presence was less significant with lower density layouts. However, this does not imply that longer link connections were less affected by human presence. As seen in figures 8-5 to 8-10, some motes, which were relatively far away from M0 or the person, showed larger RSS responses to human presence than others, which were closer. Also, the previously established relation between LOS obstruction and RSS decrease was not consistently apparent. With the motes at ground level and signal reflection or diffusion causing RSS variations in relation to human presence, as established in section 7.5, this could support the suggestion made in section 6.5, that the ratio between link length and body surface impacts the RSS response. In other words, the packets of closer motes might have reached M0 by passing through the participant's legs, whereas packets sent by motes further away might have also interacted with the torso of the participant. As the participant was not advised on the exact position of their legs, this could explain the differences in RSS responses of motes M1, M2, M3 and M4, which remained in the same positions in all three layouts.

Furthermore, figure 8-4 showed that the RSS values were consistently lower when M0's antenna was in the first position, i.e. when M0's x-axis pointed towards M1. This suggests that the TelosB antenna pattern is not symmetrically omnidirectional.

Additionally, for setups A1, B1 and C1 the overall RSS increased with someone present, whereas the opposite occurred for setups A2, B2 and C2, as depicted by figure 8-4. This confirms that reflection or diffusion cause the RSS variations due to human presence and it also demonstrates that the antennas' reception patterns are crucial to RSS data interpretation for DfL purposes.



### 8.2.4 CONCLUSION

The experiment showed that the same number of radios, spread over a larger surface area, had a lower combined RSS. Additionally, it seemed to suggest that a lower mote deployment density caused a lower response to human presence. However, it was pointed out that some longer links did show stronger RSS variations due to human presence, than shorter ones, which confirmed the suggestion made in section 6.5, that the ratio between body surface and radio link influences RSS response.

Also, the experiment demonstrated that the RX's antenna layout can result in positive as well as negative RSS responses to human presence, which reaffirmed that signal reflection and diffusion are the dominant mechanisms for DfL. Besides, it highlighted that the antenna pattern of TelosB motes is not spherical along with the implications for RSS data interpretation.

## 8.3 QUANTITY

With the proposed concept of using the infrastructure of an automation control system for DfL purposes, the layout of the motes might be dictated by the positions of the automation equipment, which are predominantly placed on surface areas such as walls. Hence, the radio density might be imposed by the internal structures of the dwelling, however the radio quantity can be altered. Therefore, the optimal number of motes for occupant detection was investigated.

### 8.3.1 METHODOLOGY

Three setups based on section 8.2's Layout-A, depicted in figure 8-1, were compared. Setup A1, described in section 8.2.1 and represented in figure 8-11, was taken as reference to the previous experiment. The other two setups were based on a layout called Layout-AA, which had the same mote distribution as Layout-A, however the motes were placed on 0.75 m high wooden poles and formed a 4 m by 4 m square, as shown in figure 8-12. Setup AA3 had M0's x-axis pointing towards M5 and similarly to A1, its y-axis pointed towards the sky. Setup AA4, which is depicted in figure 8-12, had M0's x-axis pointing towards the sky and its y-axis towards M7.

As per definition, M0 was programmed as a RX. All other motes were TXs, which sent packets simultaneously. During the experiment they were switched on in stages, first M1 and M2, then M1 to M4, then M1 to M8 and finally all sixteen TXs. 100 measurements were taken each time with the area being empty and with someone present between M0 and M1, as shown in figure 8-1. The resulting data was referred to as either “E” or “P”, meaning “empty” or “present”, and the number of transmitting motes. The eight data sets were hence called E2, P2, E4, P4, E8, P8, E16 and P16.

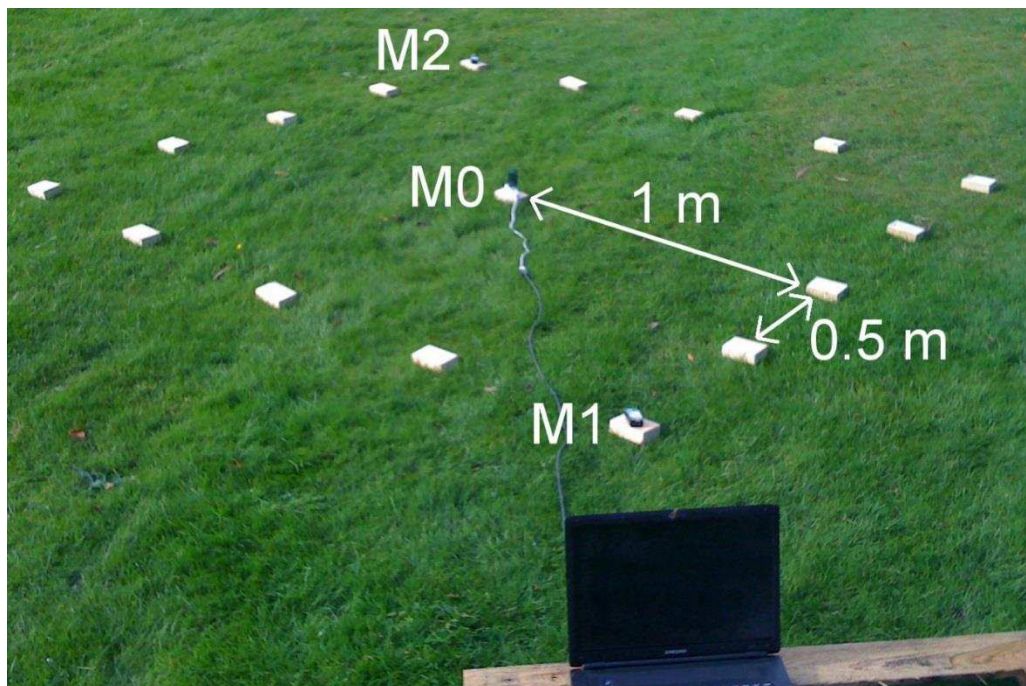

FIGURE 8-11: SETUP A1

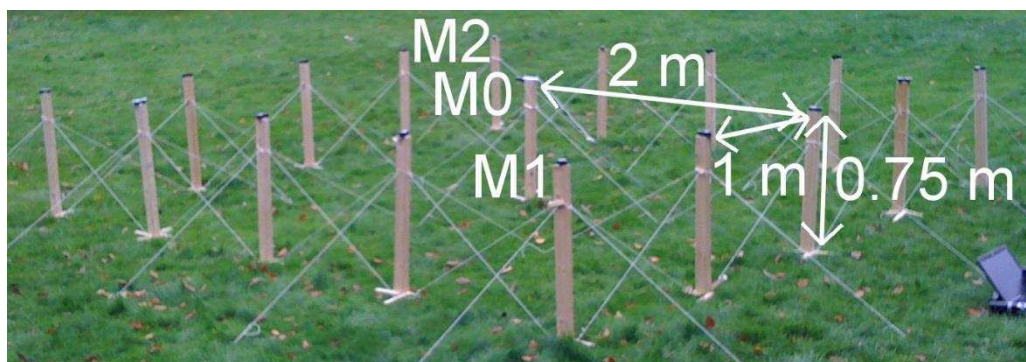

FIGURE 8-12: SETUP AA4

### 8.3.2 RESULTS

The differences in mean RSS values between the empty and present scenarios for all three setups were represented in figures 8-13, 8-14

and 8-15. Also, the ranges of empty and present RSS values were highlighted for scenarios with several measurements.

The mean RSS values per mote per scenario as well as the differences between empty and present measurements were shown in table 8-1.

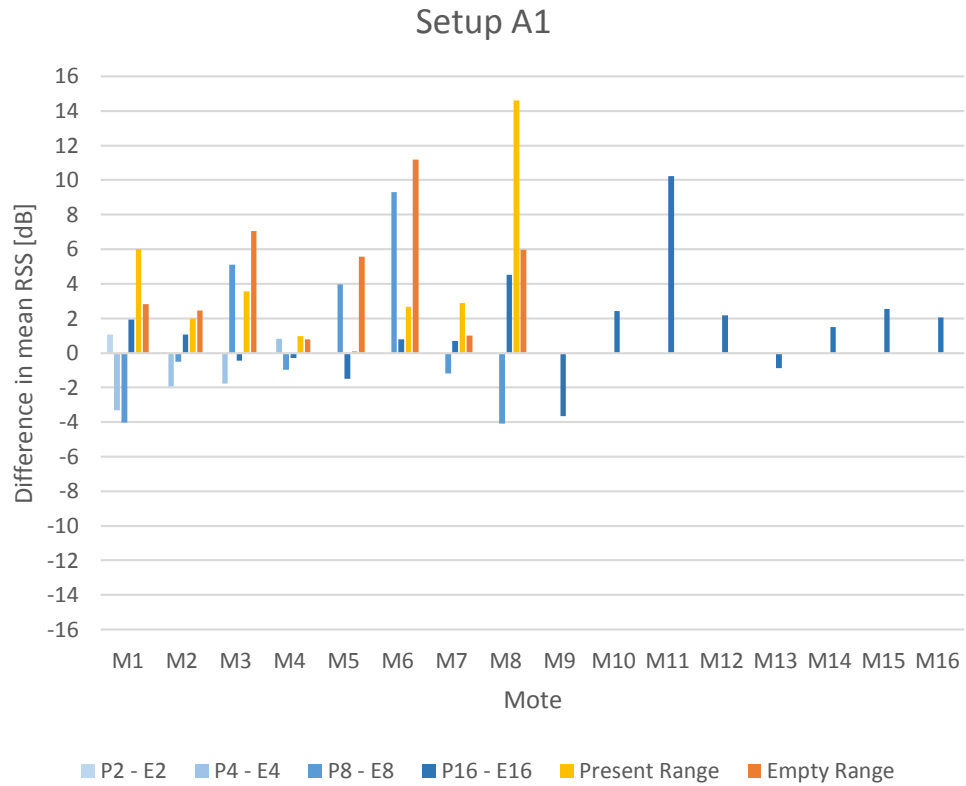

FIGURE 8-13: DIFFERENCES AND RANGES OF EMPTY AND PRESENT SCENARIOS FOR SETUP A1

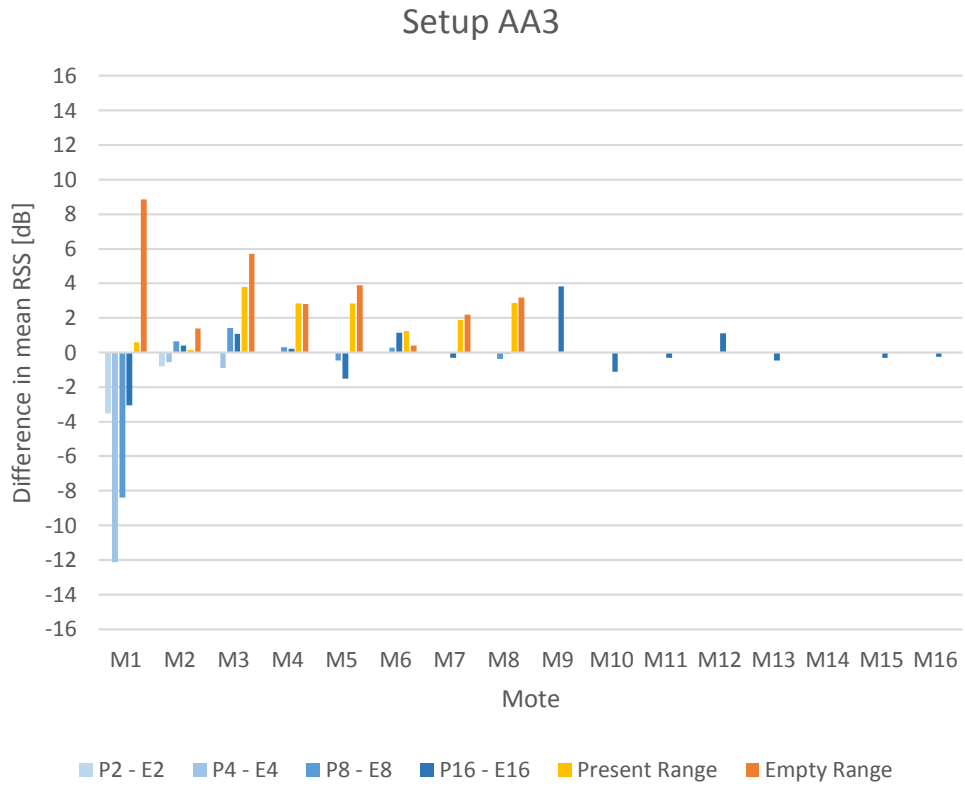

FIGURE 8-14: DIFFERENCES AND RANGES OF EMPTY AND PRESENT SCENARIOS FOR SETUP AA3

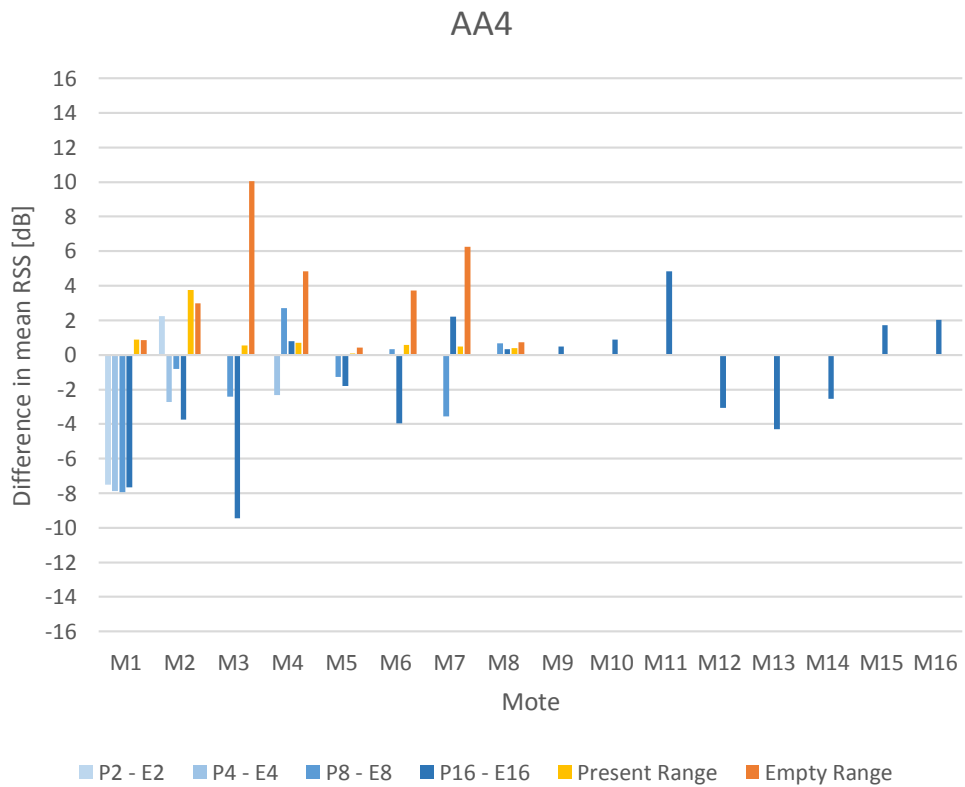

FIGURE 8-15: DIFFERENCES AND RANGES OF EMPTY AND PRESENT SCENARIOS FOR SETUP AA4

Mean RSS [dB] per mote	A1	AA3		AA4		
		Difference		Difference		Difference
E2	-67.6	0.6	-58.6	-2.2	-54.4	-2.6
P2	-67.0		-60.8		-57.0	
E4	-65.1	-1.5	-58.3	-3.4	-54.6	-3.2
P4	-66.6		-61.7		-57.8	
E8	-64.3	1.0	-56.5	-0.8	-53.4	-1.5
P8	-63.4		-57.3		-54.9	
E16	-65.6	1.4	-56.7	0.0	-55.7	-1.4
P16	-64.1		-56.7		-57.1	
Overall Mean	-64.9	0.9	-57.4	-0.8	-55.7	-1.8

TABLE 8-1: MEAN RSS VALUES AND DIFFERENCES PER SCENARIO AND PER SETUP

### 8.3.3 DISCUSSION

The results shown in table 8-1 suggested that four motes, i.e. one in each corner of the monitored area, were the optimal number for occupancy detection, as the differences between P4 and E4 yielded the greatest overall decreases in RSS for each of the setups. In contrast, figures 8-13 to 8-15 highlighted that during the two motes and four motes scenarios, it was primarily M1 which reacted to human presence, and that during the remaining scenarios, other motes also reacted to human presence with increased or decreased RSS. Furthermore, it is noteworthy that the combined responses for motes M9 to M16 seemed to form a sinusoid like pattern, which supports that those variations did correspond to the human interference. Hence, the more radio connections there are, the more potential information for DfL.

Also, the overall difference per setup, shown in table 8-1, highlighted that for A1 the RSS increased with someone present, whereas it decreased for AA3 and AA4. Additionally, the overall mean RSS per mote was lowest for A1. This confirmed the findings of section 7.4, that motes need to be elevated, and supported the suggestion reiterated in section 8.2, that the body surface in relation to the direct LOS affects the RSS response. The fact that during both setups, A1 and AA3, M0's y-axis pointed towards the sky also highlighted, that the RX's antenna position alone does not

dictate the polarity of the RSS response to human presence, as seen in section 8.2.

However, as highlighted by figures 8-14 and 8-15, the differences in M0's positioning created significant differences in the responses of each mote to human presence. In setup AA3, M1 and M9 were the only two motes to respond to the person standing in the direct LOS of M1 and M0. In addition, the empty measurements range was quite wide for M1, which caused an inconsistent response pattern. On the other hand, in setup AA4 the majority of motes reacted to human presence and M1's RSS response was very consistent. This suggested that the position of a TelosB RX's antenna can be used to differentiate between omnidirectional and unidirectional reception patterns.

#### 8.3.4 CONCLUSION

The experiment suggested that an increased number of radio connections yielded a larger amount of potentially valuable information for DfL purposes. It also highlighted the directionality differences in antenna reception patterns for two tested setups. The suggestion which was mentioned in previous sections, that the relation between body surface and direct LOS affected RSS response to human presence and that therefore radios should be placed at an appropriate height, was confirmed.

### 8.4 LOCALISATION

The requirements for an occupant detection technology applicable to COAC, as outlined in section 3.4.2, included occupant localisation. Based on chapter 5's conclusion, that outdoor experiments were required to assess DfL's capabilities, and on section 8.3's findings, an experiment was designed to examine the accuracy of DfL localisation.

#### 8.4.1 METHODOLOGY

The AA3 setup, mentioned in section 8.3, was used due to its demonstrated unidirectional responsiveness to human presence. However, the motes were renamed for the purpose of this experiment, as shown in figure 8-16. A person was asked to stand in the positions A to H. In the positions A and B the person faced

M6, in C and D M10, in E and F M14 and in G and H M2. 100 measurements were taken each time. Also, the RSS of all connections was measured when the area was empty.

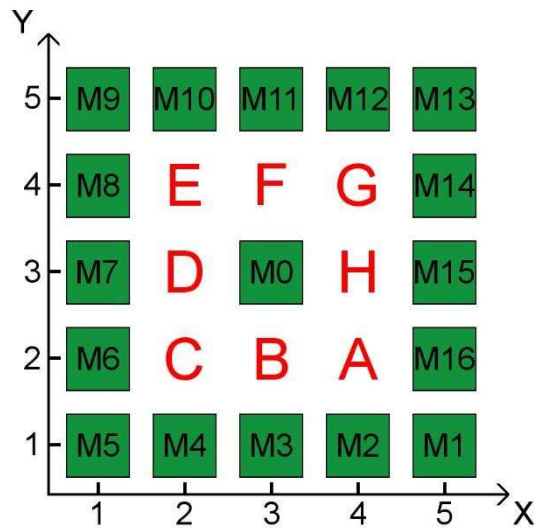

FIGURE 8-16: SETUP AA3 WITH POSITIONS A TO H

#### 8.4.2 RESULTS

The mean RSS values for the empty measurements as well as for each position the person stood in were represented in figure 8-17. Also, the empty measurements were deducted from the positional values, as shown in figure 8-18.

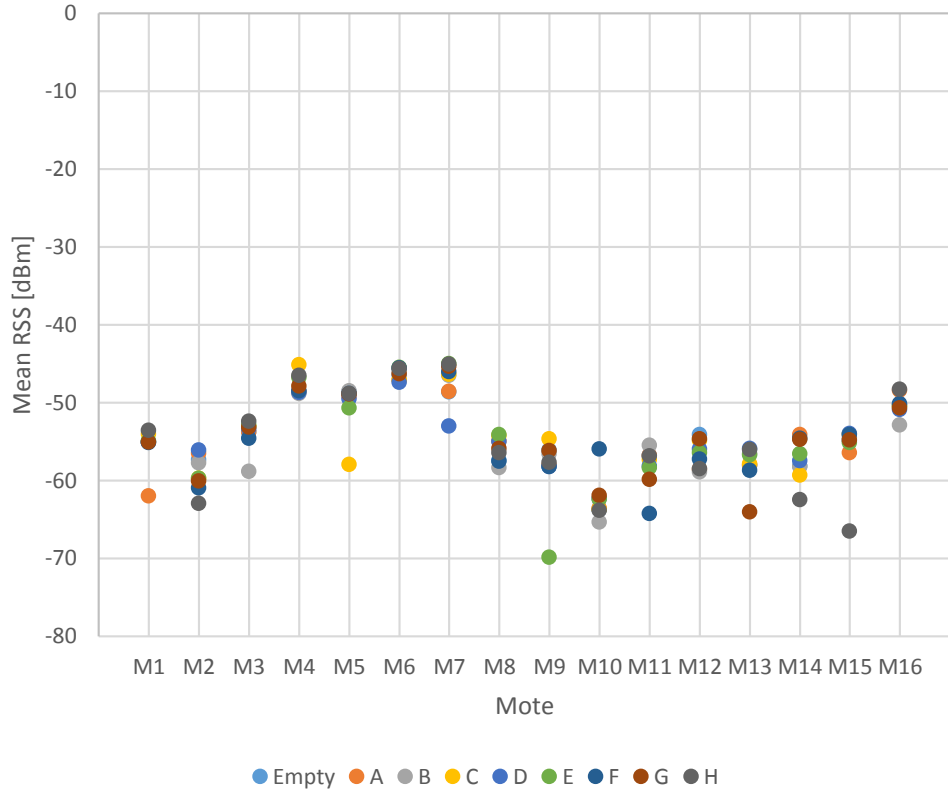

FIGURE 8-17: MEAN RSS VALUES OF EMPTY AND POSITIONAL MEASUREMENTS

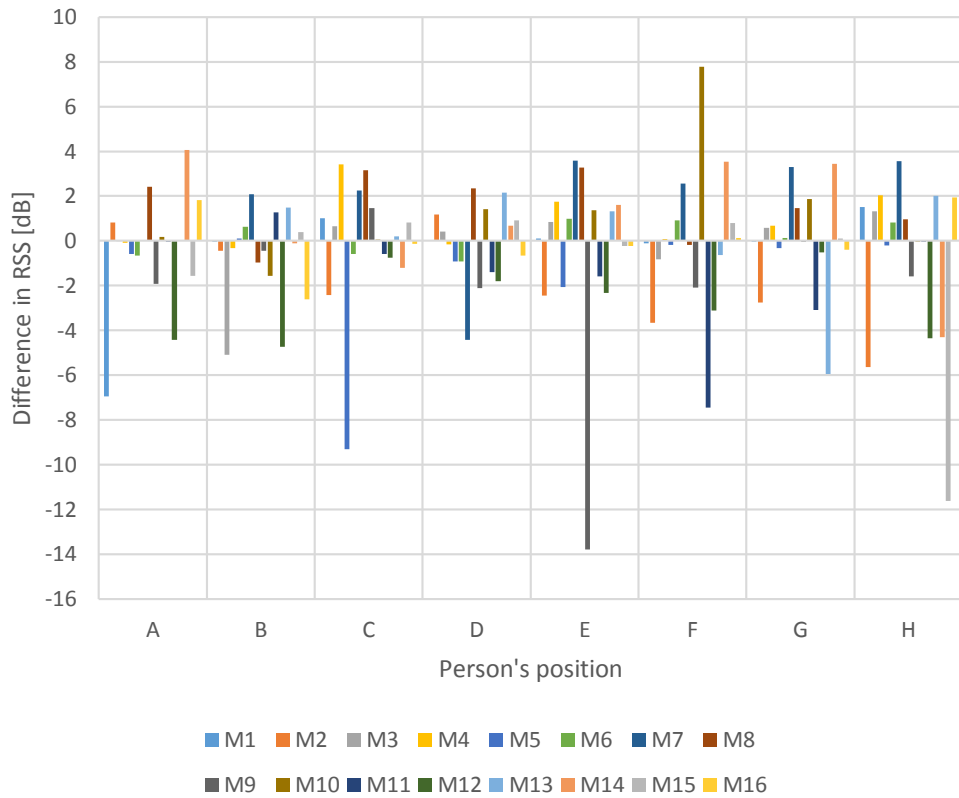

FIGURE 8-18: DIFFERENCE BETWEEN POSITIONAL AND EMPTY MEASUREMENTS



### 8.4.3 DISCUSSION

The results showed that this experiment was 100 percent accurate in identifying the person's position, if the interpretation method was solely based on the concept of LOS obstruction causing a decrease in RSS. The largest decreases in RSS for a given position in figure 8-18 consistently corresponded to the link whose LOS was obstructed, as depicted by figure 8-16. However, for some positions, other links also showed a significant RSS drop, such as  $L_{M12 \rightarrow M0}$  for position B, which could lead to inaccuracies, if no links corresponding to the direct LOS were available. Therefore, it is suggested that the RSS distribution over several measurements, as shown in figure 8-17, should be analysed to distinguish the relevance of a link's RSS response, as a measured empty value might not always prove to be an effective reference.

Increased RSS values, with magnitudes similar to the discussed RSS drops, were also measured, as shown by position F in figure 8-18 for example. The fact that some of them occurred for motes, which were next to those whose LOS was obstructed, seemed to indicate that signal multipath were created by the human body, which would implicitly confirm section 8.2's findings that DfL could benefit from denser mote deployment. However, the asymmetrical manifestation of those increases, as well as the asymmetrical magnitude of RSS drops caused by LOS obstruction, which might both be due to M0's antenna pattern, could prove challenging to data interpretation for DfL localisation purposes.

### 8.4.4 CONCLUSION

The experiment demonstrated 100 percent accuracy in identifying eight positions taken by a person in a 16 m<sup>2</sup> outdoor area by analysing the RSS decreases of sixteen radio links due to LOS obstruction. However, data misinterpretation, especially due to link scarcity, was discussed and the analysis of RSS distribution per link was suggested. Also, the findings of sections 8.2 and 8.3, that denser and more radio connections would be beneficial to DfL, were confirmed.

## 8.5 MULTIPLE PEOPLE LOCALISATION

Another requirement for COAC implementation was the localisation of all occupants, as described in section 3.4.2. Therefore, an experiment was designed, based on the previous experiment described in section 8.4, to investigate whether DfL was capable of localising several people simultaneously.

### 8.5.1 METHODOLOGY

Setup AA3, which was discussed in section 8.4 and depicted in figure 8-16, was used.

Initially, measurements were taken with the monitored area being empty. This was then repeated with one person standing in position A. The resulting data set was called P1. Afterwards, a second person was asked to stand in positions C, E and G subsequently, while the first person stayed in position A. The measurements taken were referred to as P2C, P2E and P2G, respectively. During each measurement 100 RSS values were recorded.

### 8.5.2 RESULTS

The mean RSS of all measurements was represented in figure 8-19. Also, the empty measurement was subtracted from P1's, P2C's, P2E's and P2G's measurements, which resulted in the values represented in figure 8-20.

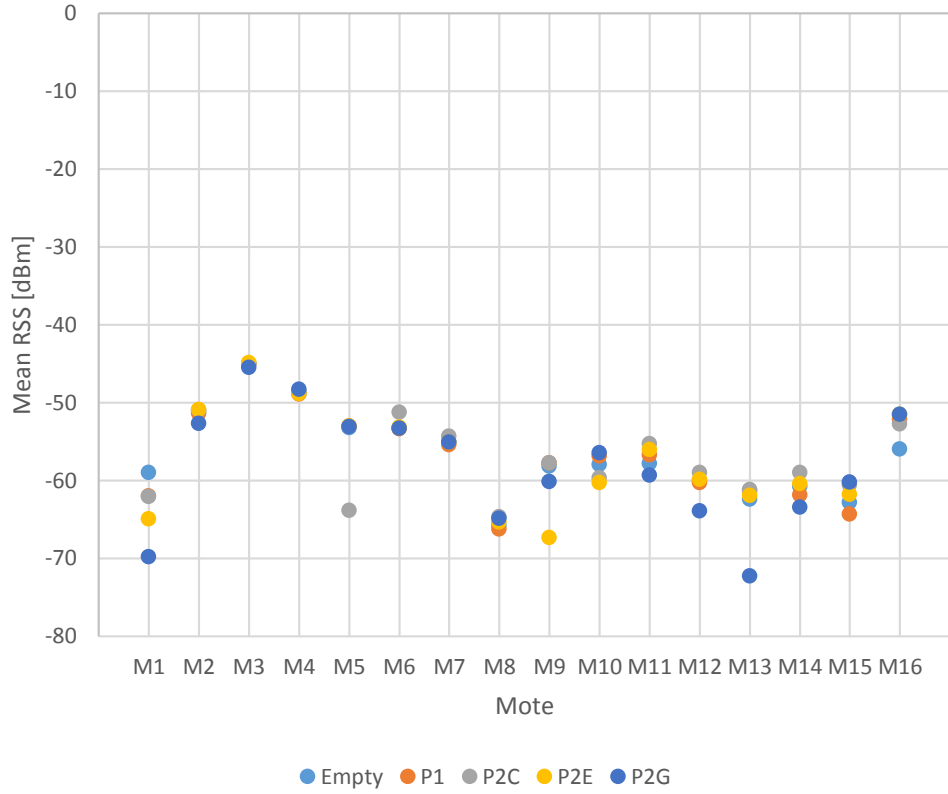

FIGURE 8-19: MEAN RSS PER MOTE AND PER SCENARIO

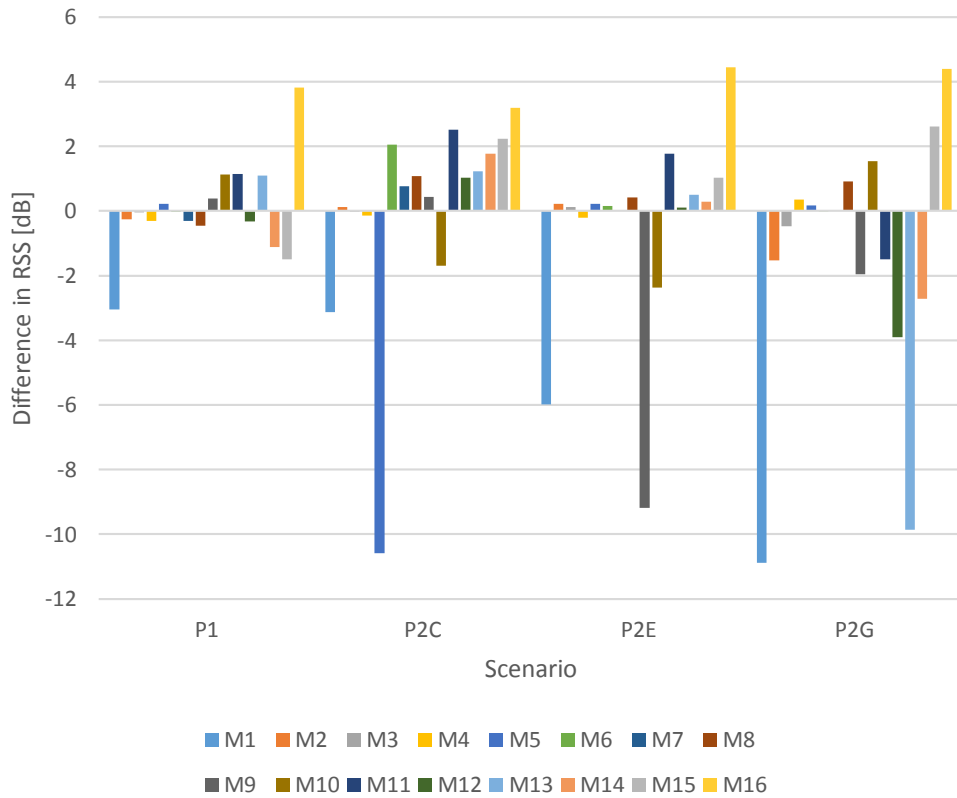

FIGURE 8-20: DIFFERENCE BETWEEN VALUES WITH AND WITHOUT SOMEONE PRESENT

### 8.5.3 DISCUSSION

The results demonstrated that simultaneous localisation of two people using DfL was feasible and accurate. In each of the scenarios tested, the LOS of the links with the largest RSS decreases corresponded consistently to the one or two positions which were occupied, as shown by figure 8-20. The RSS distribution per link, which was suggested by section 8.4 as an alternative analysis method, also confirmed these findings, as represented in figure 8-19.

The links, which were located next those with obstructed LOS, also seemed to react to human presence, as shown by figures 8-19 and 8-20.  $L_{M16 \rightarrow M0}$  had increased RSS values for all scenarios, as a person stood in position A each time. Similarly,  $L_{M6 \rightarrow M0}$  had an increased RSS when the second person stood in position C. However, with the second person in positions E and G, the RSS of the links  $L_{M10 \rightarrow M0}$  and  $L_{M12 \rightarrow M0}$  as well as  $L_{M14 \rightarrow M0}$ , respectively decreased. Multipath signals, such as reflections or diffusions, were probably the cause for those reactions. However, unlike section 8.4.3 suggested, it was not M0's antenna pattern that influenced the polarity or magnitude of RSS responses, but probably slight variations in the person's position or posture, as indicated by  $L_{M1 \rightarrow M0}$ 's significant variations for repetitive occupation of position A.

### 8.5.4 CONCLUSION

It was established that the localisation of multiple people based on the simultaneous obstruction of several links' LOS was feasible, which was consistent with section 8.4's findings. Furthermore, it was shown that human presence in the proximity of LOS transmission could provide valuable information; and it was suggested that variations in RSS response were caused by human induced changes.

## 8.6 TRACKING

The final requirement for an occupant detection technology to be applicable to COAC was its ability to track people, as outlined in section 3.4.2. The previous sections 8.4 and 8.5 demonstrated the ability to localise people, who obstructed the LOS of a radio communication link. Based on those findings, the following

experiment investigated the extent to which a person can be tracked.

### 8.6.1 METHODOLOGY

The AA3 setup, which was employed by the experiments discussed in sections 8.4 and 8.5, was used again.

100 RSS measurements with an empty area were taken per mote. A person was then asked to walk one, two and three times along the inner circle, represented in blue in figure 8-21. Additionally, they were asked to walk once along the inside and follow up by walking along the outside, i.e. the path represented in orange in figure 8-21. The person always kept an approximate one meter distance of the nearest motes. These scenarios will be referred to as X1, X2, X3 and Y1, respectively. For each of the four trajectories, the person used the gap between M15 and M16 to enter and exit. Similarly, the outside round of trajectory Y1 finished at that level.

On all four occasions the person entered the inner circle approximately ten seconds after the recording started.

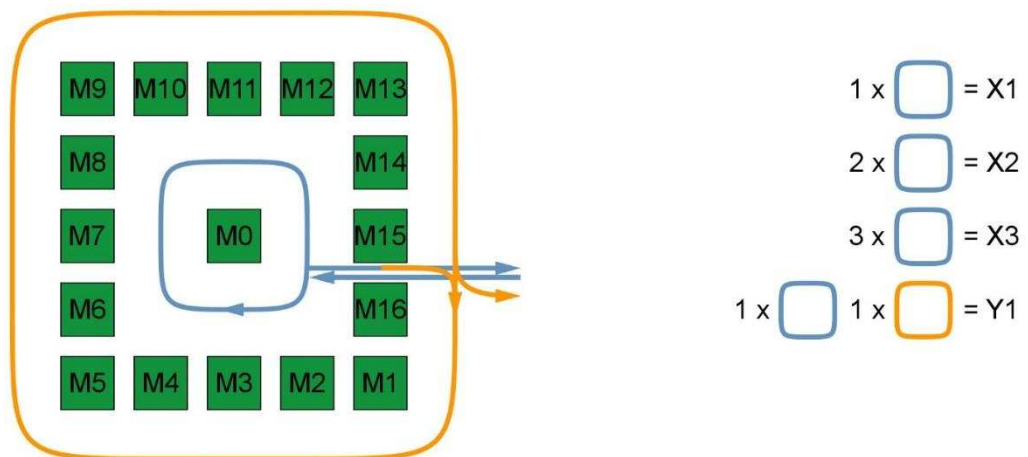

FIGURE 8-21: SETUP AA3 WITH THE DIFFERENT TRAJECTORIES TAKEN BY THE PERSON

### 8.6.2 RESULTS

The mean RSS values for an empty area were subtracted of each mote's instantaneous values, resulting in the data represented in figures 8-22, 8-23, 8-24 and 8-25 for X1, X2, X3 and Y1, respectively.

Trajectory X1

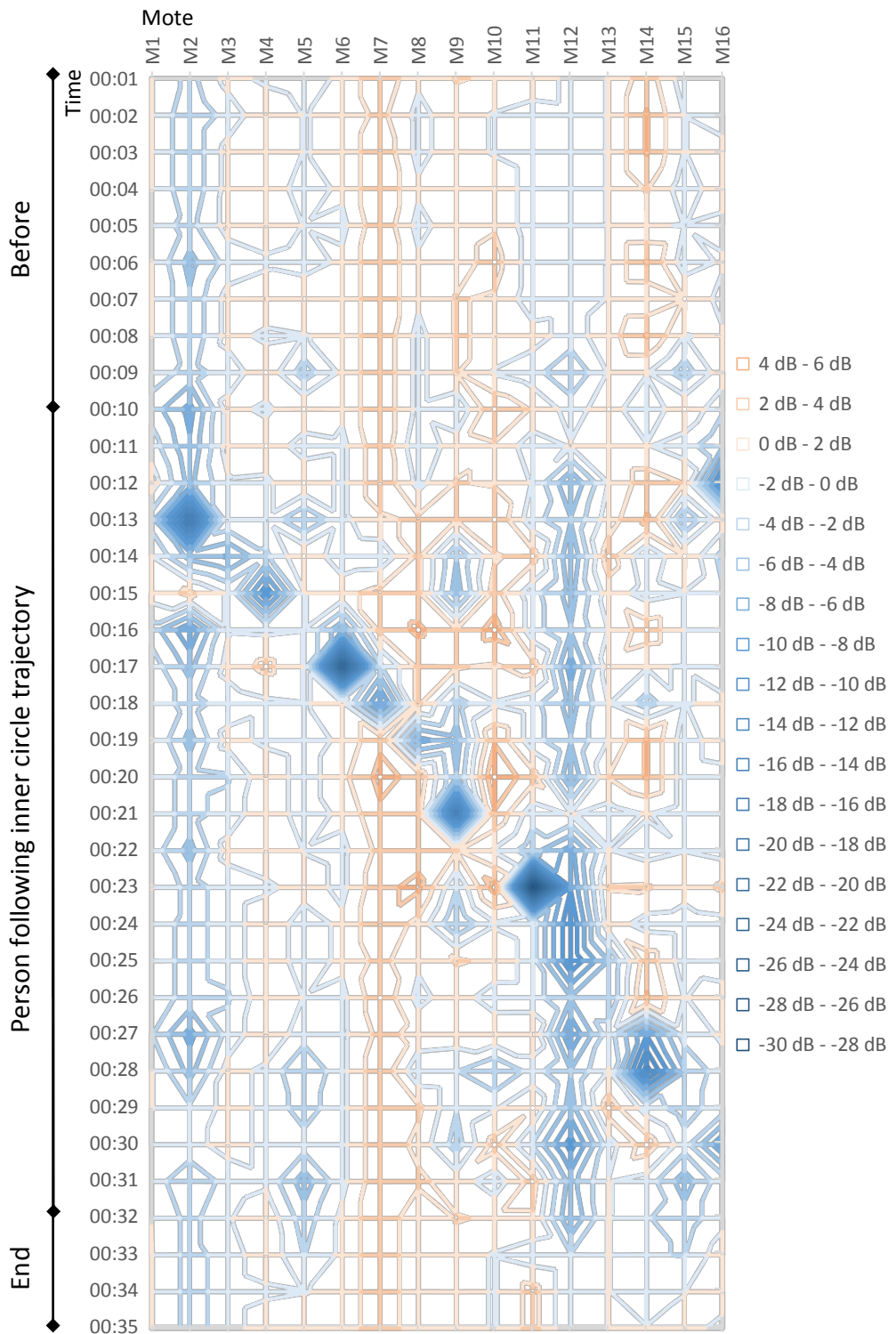

FIGURE 8-22: RSS RESPONSE TO A PERSON WALKING ALONG TRAJECTORY X1

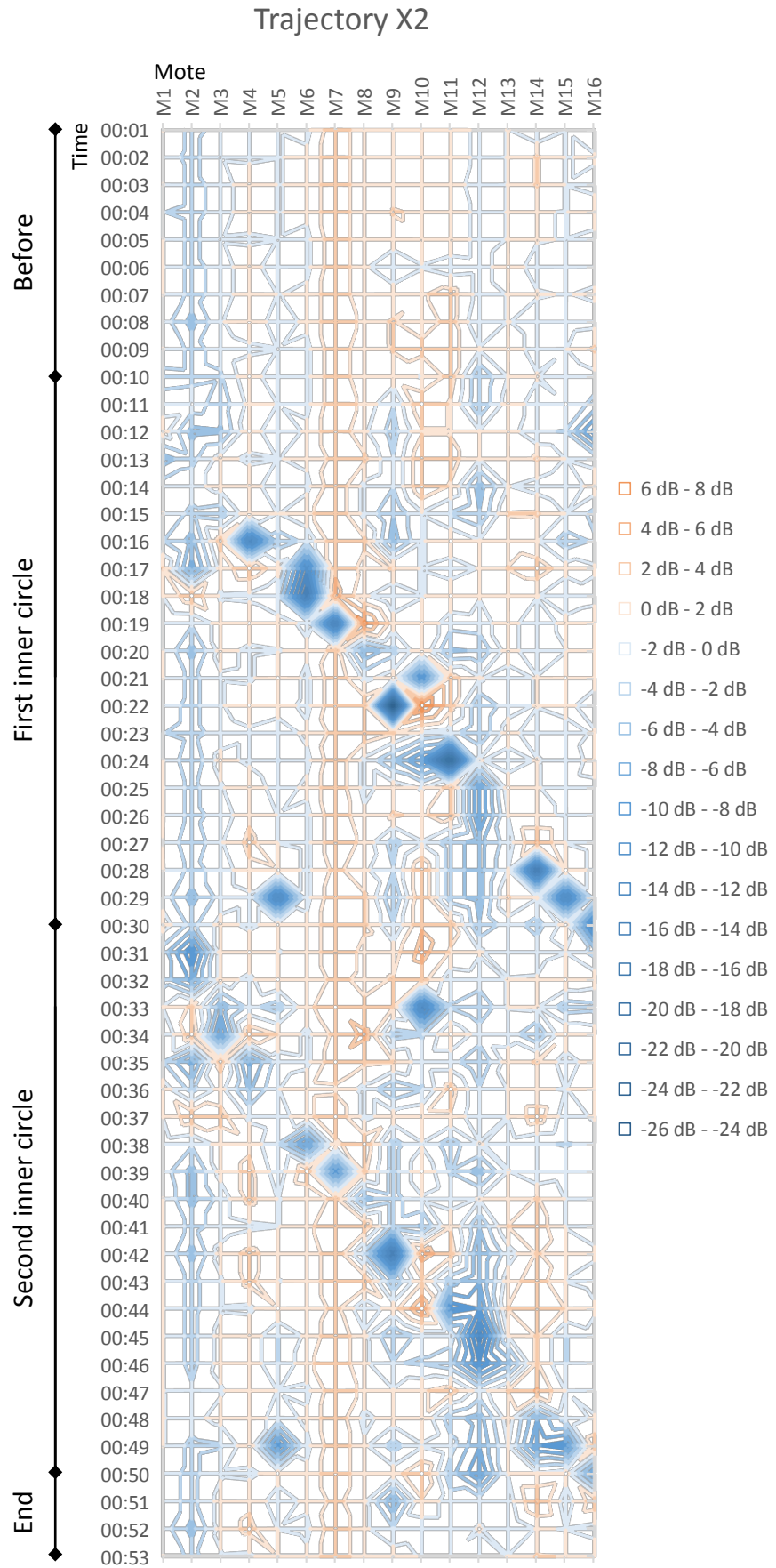

FIGURE 8-23: RSS RESPONSE TO A PERSON WALKING ALONG TRAJECTORY X2

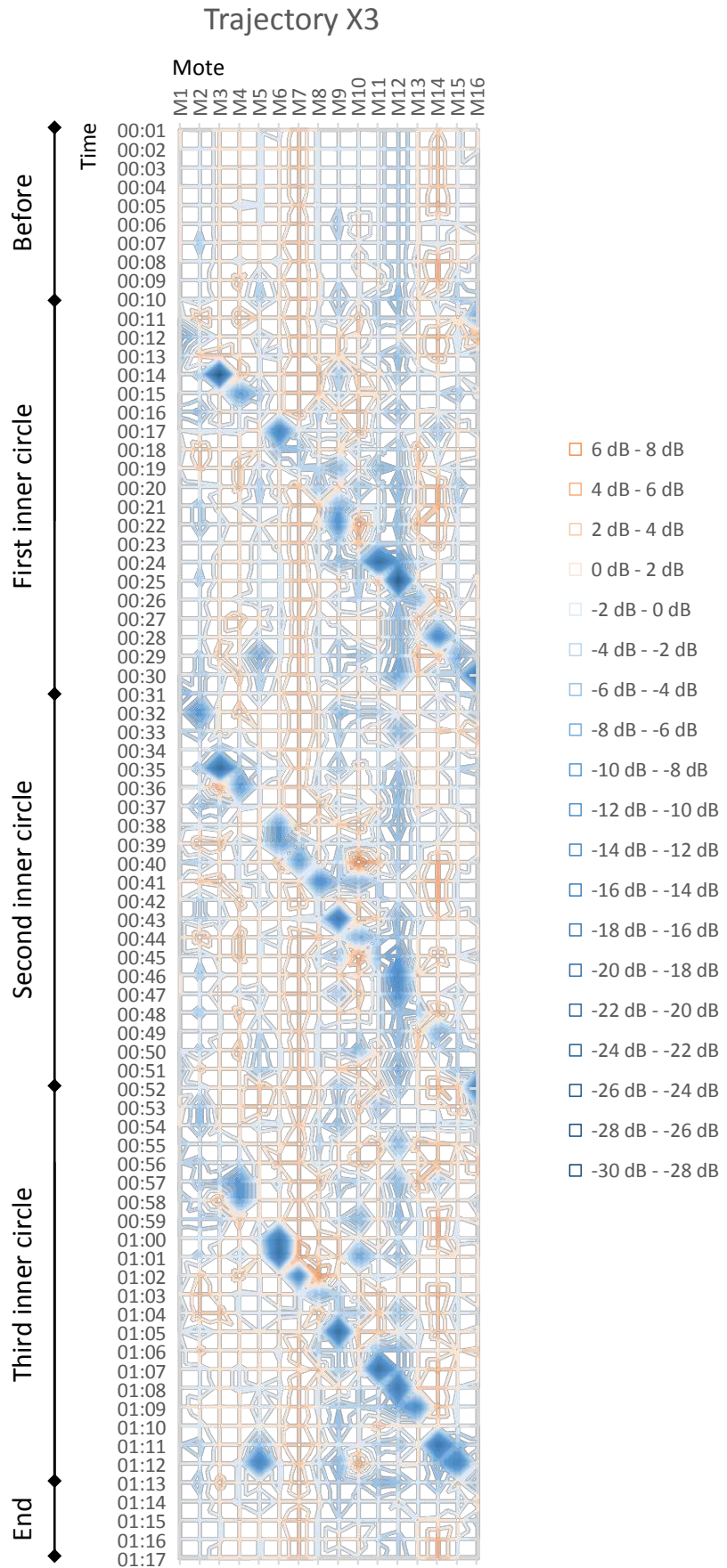

FIGURE 8-24: RSS RESPONSE TO A PERSON WALKING ALONG TRAJECTORY X3



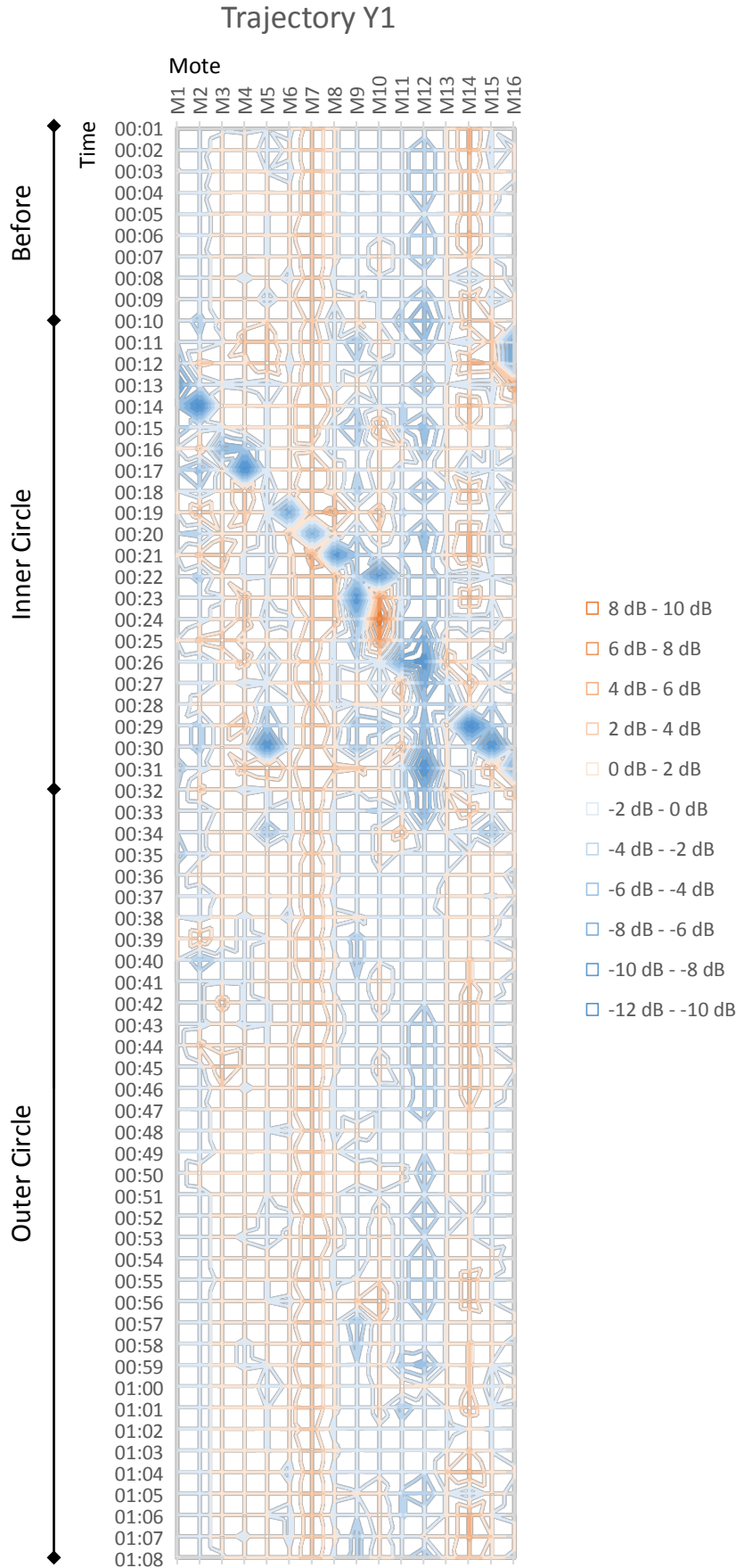

FIGURE 8-25: RSS RESPONSE TO A PERSON WALKING ALONG TRAJECTORY Y1

### 8.6.3 DISCUSSION

The results showed that a person can be tracked based on the LOS obstruction of radio links. Figures 8-22 to 8-25 represented a diagonal of RSS drops for each inner circle the person made, which corresponded to the direction the person was walking in, as shown in figure 8-21. The approximate positions per LOS obstruction, also seemed correct as  $L_{M16 \rightarrow M0}$  was always the first link to decrease in RSS, with the others following in sequential order.

However, some links did not show a RSS response to the person's presence, or at a different time than when their LOS was obstructed, such as  $L_{M5 \rightarrow M0}$  for example, which showed RSS decreases simultaneously to  $L_{M15 \rightarrow M0}$  in most of the scenarios. This could suggest that multipath signals were created by the person, as suggested in several of the previous experiments.

On the other hand, the experiments in sections 8.4 and 8.5, which used the same setup AA3 as this experiment, did demonstrate a relation between LOS obstruction and RSS drop for  $L_{M5 \rightarrow M0}$ . Hence, the person's movement pattern in relation to the signal transmission of this link might be responsible for the missing RSS drop at the time of LOS obstruction. In other words,  $L_{M5 \rightarrow M0}$ 's packets, as it was not a continuous transmission, might have been sent immediately before and after the person obstructed the LOS. This suggests that the temporal resolution of DfL would need to be adjusted in relation to the tracking accuracy required by the COAC system.

Furthermore, as shown by figure 8-25, the path followed around the outside of the square of motes was not detectable, as neither in- nor de-creases in RSS seemed to occur. However, the experiment in section 6.5, which examined two meter radio connections, found a slight increase in RSS with a person standing immediately behind the radio. This could suggest that the one meter distance between the person and the motes was too significant to impact the RSS. With regards to COAC, this might reduce the expected coverage of DfL, but it might also be beneficial, as monitoring people outside the desired area, such as adjoining neighbours, could create legal privacy issues.

#### 8.6.4 CONCLUSION

The experiment demonstrated that a moving person can be tracked using the LOS of several radio links. Additionally, it was indicated that tracking people behind radios' direct LOS might not be feasible, which could be advantageous in terms of restricting the tracking of people outside the desired area. Also, previous suggestions that the human body creates multipath signals, were supported by this experiment, and it was highlighted that the temporal resolution of DfL might need to be adjusted to COAC system requirements.

### 8.7 CHAPTER CONCLUSION

Part B of the comprehensive DfL study investigated radio network layouts and assessed the capabilities of DfL with regards to the requirements set out by a potential COAC system, as discussed in section 3.4.2. The experiments' findings suggested that the general DfL implementation guidance was to increase the density and quantity of radio connections. Thus, the potential information created by LOS obstructions or multipath transmissions due to human interference would allow for more accurate occupant detection. Additionally, it was reaffirmed that radios should be placed at an elevated level in order to increase the ratio of human body surface to direct LOS, which affects the RSS response. An RSS data interpretation method, using the distribution, rather than relying on empty versus present differences, was also suggested.

Furthermore, it was demonstrated that accurate localisation of one and several people was feasible, based on RSS drops caused by LOS obstruction. Similarly, DfL's ability to track a person, who was moving inside an area covered by several radio links' LOS, was shown. Hence, DfL was proven to possess all the requirements necessary for an application to COAC. However, it was pointed out that DfL's temporal resolution required investigation, which was realised by an experiment described in part C of the comprehensive study, discussed in chapter 9.

## **9 DFL – COMPREHENSIVE STUDY – PART C**

### **9.1 INTRODUCTION**

Part A and B of the comprehensive study, described in chapters 7 and 8, discussed DfL with regards to indoor signal propagation and developed guidance for network layout. Also, DfL's abilities to localise one or several people, as well as track them, were demonstrated. Part C of the comprehensive study investigated DfL applied to a real life scenario dwelling and the extent to which occupancy could be detected. In addition, various temporal resolutions were examined, as the integration of DfL into an automation control system's infrastructure might require a compromise between the accuracy of occupant detection and COAC operation.

### **9.2 TEMPORAL RESOLUTION AND HOUSE OCCUPANCY**

Section 8.6 suggested that DfL's accuracy depended on its temporal resolution. Hence, an experiment was designed to investigate three different temporal resolutions and their impacts on occupant detection. Also, with COAC, the intended DfL application, requiring a whole house approach, as outlined in chapter 3, the following experiment was set in a dwelling with realistic domestic conditions.

#### **9.2.1 METHODOLOGY**

An end of terrace house, with two permanent occupants, was used as a test environment. Eighteen transmitting TelosB motes, described in section 7.2, were distributed over the two floor levels, as depicted in figure 9-1. They were all placed in the rooms' corners and at floor level, except M9 and M10 which were positioned on the kitchen work surface. The receiving mote, M0, was placed on the dining table, as this was the most central position.

Three temporal resolution scenarios were investigated. The TXs were programmed to either submit a packet every second, every

minute or every ten minutes. For each of the three scenarios RSS data was collected over more than three days.

During the experiment, both occupants wrote down every room change they made with a one minute resolution. However, due to differences between their clocks and between theirs and the computer's clock, a precision error of  $\pm 1$  min can reasonably be expected.

Also, for the occupancy data transcription of the 1 s resolution test the transitions through other rooms were assumed to have taken between 20 and 30 s. These transitions were not accounted for in the occupancy data of the 1 min and 10 min resolution tests.



FIGURE 9-1: FLOOR PLANS WITH MOTE POSITIONS

### 9.2.2 RESULTS

For each of the three scenarios one day of data was compiled and represented in figures 9-2 to 9-19. Figures 9-2 to 9-7 show the occupancy and RSS data for all six rooms of the dwelling for the 1 s resolution test. Similarly, figures 9-8 to 9-13 and 9-14 to 19 present

those values for the 1 min and 10 min resolution tests, respectively. Due to data clarity of the figures, only the RSS data of the four motes which encircled the concerned room, were included. For the kitchen, M7, M8, M9 and M10 were chosen for this purpose, and for the bathroom, which had no motes in it for humidity reasons, M9 and M10 were chosen, because of their elevation, as well as M17 and M18.

During the experiment, some batteries failed and were replaced. Therefore, it was chosen not to represent the lost packets in any of the figures. Also, during the 1 s resolution test 11 s of measurements were lost during four separate instances.

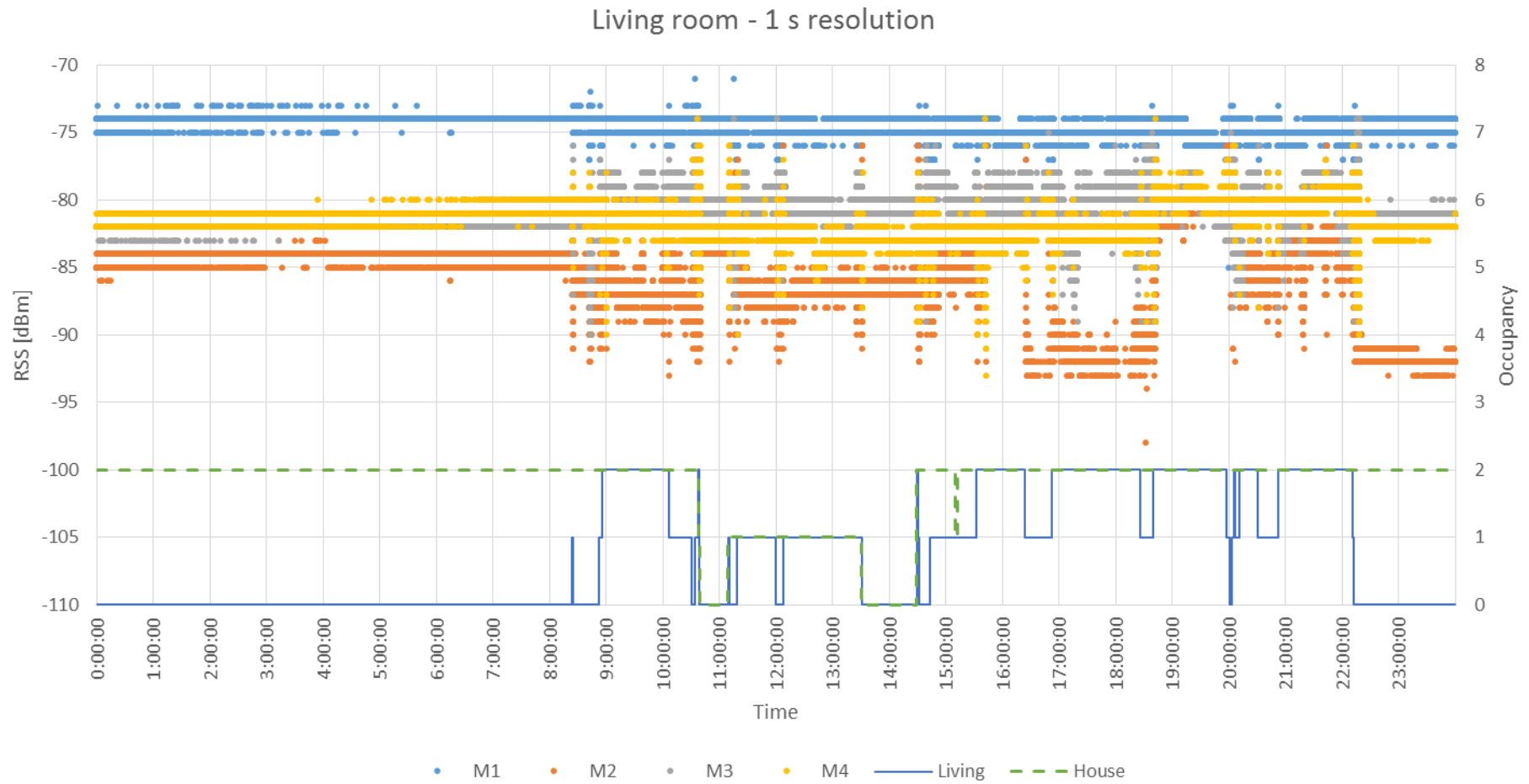

FIGURE 9-2: RSS RESPONSES TO LIVING ROOM OCCUPANCY AT ONE SECOND RESOLUTION





FIGURE 9-3: RSS RESPONSES TO DINING ROOM OCCUPANCY AT ONE SECOND RESOLUTION

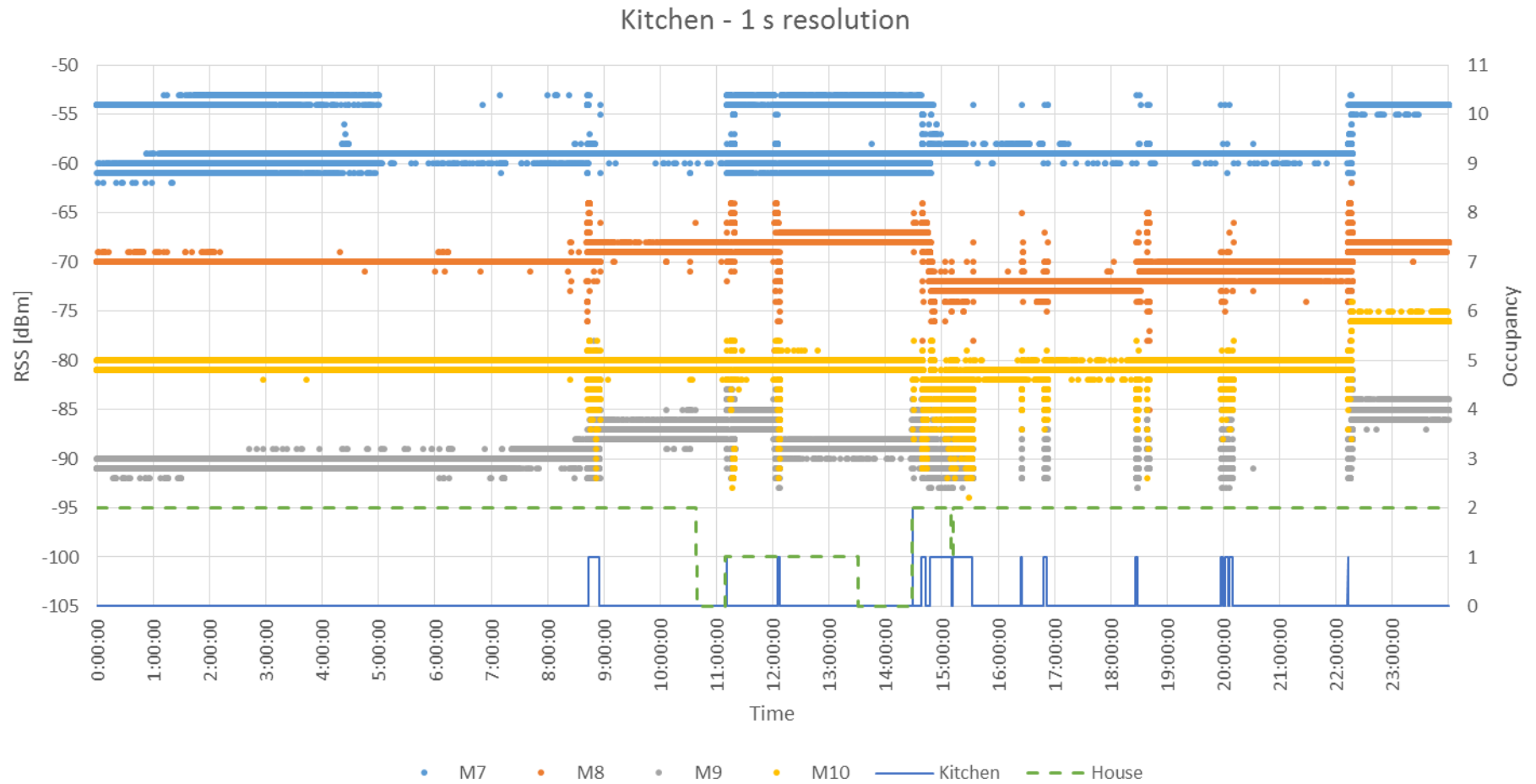

FIGURE 9-4: RSS RESPONSES TO KITCHEN OCCUPANCY AT ONE SECOND RESOLUTION

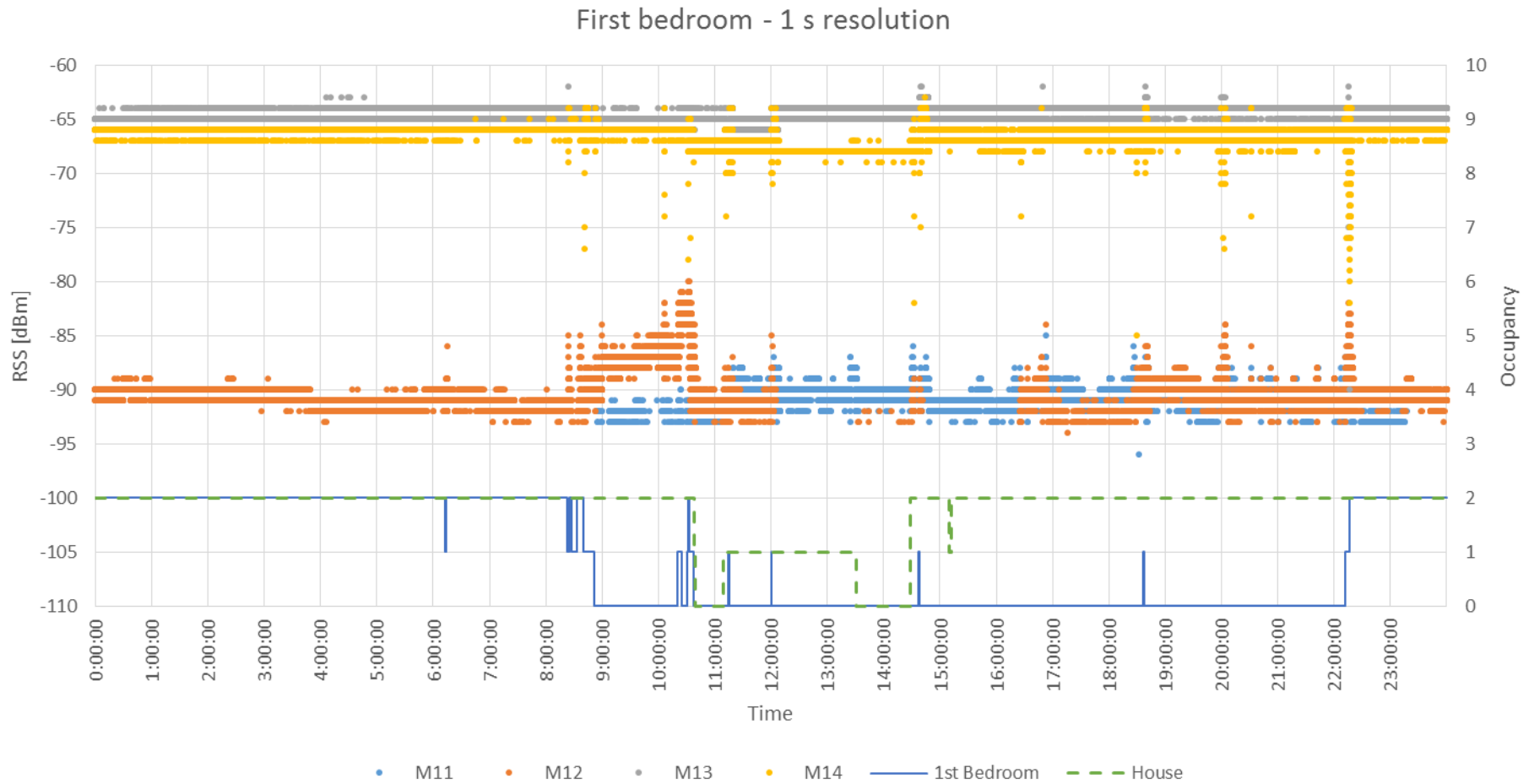

FIGURE 9-5: RSS RESPONSES TO FIRST BEDROOM OCCUPANCY AT ONE SECOND RESOLUTION

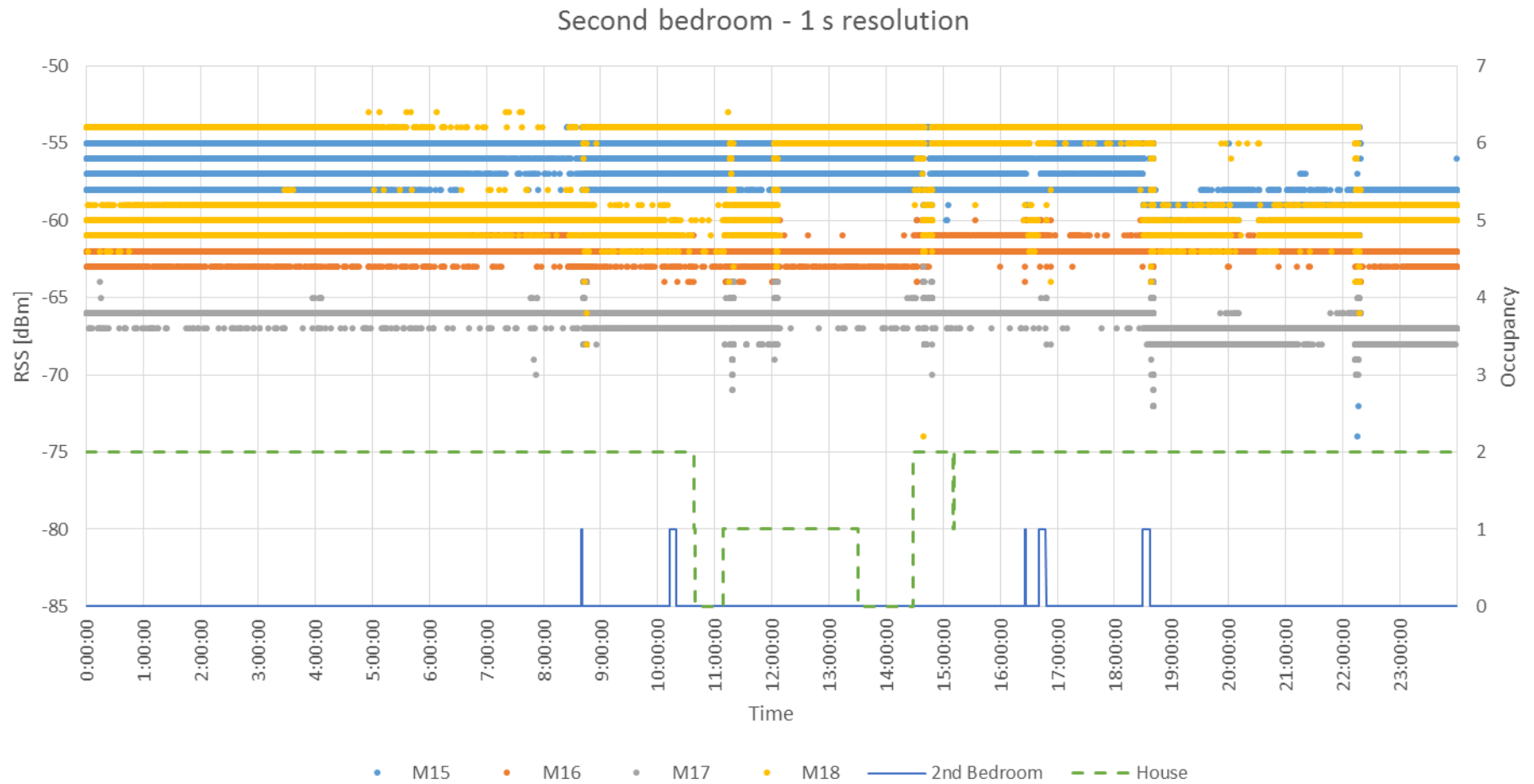

FIGURE 9-6: RSS RESPONSES TO SECOND BEDROOM OCCUPANCY AT ONE SECOND RESOLUTION

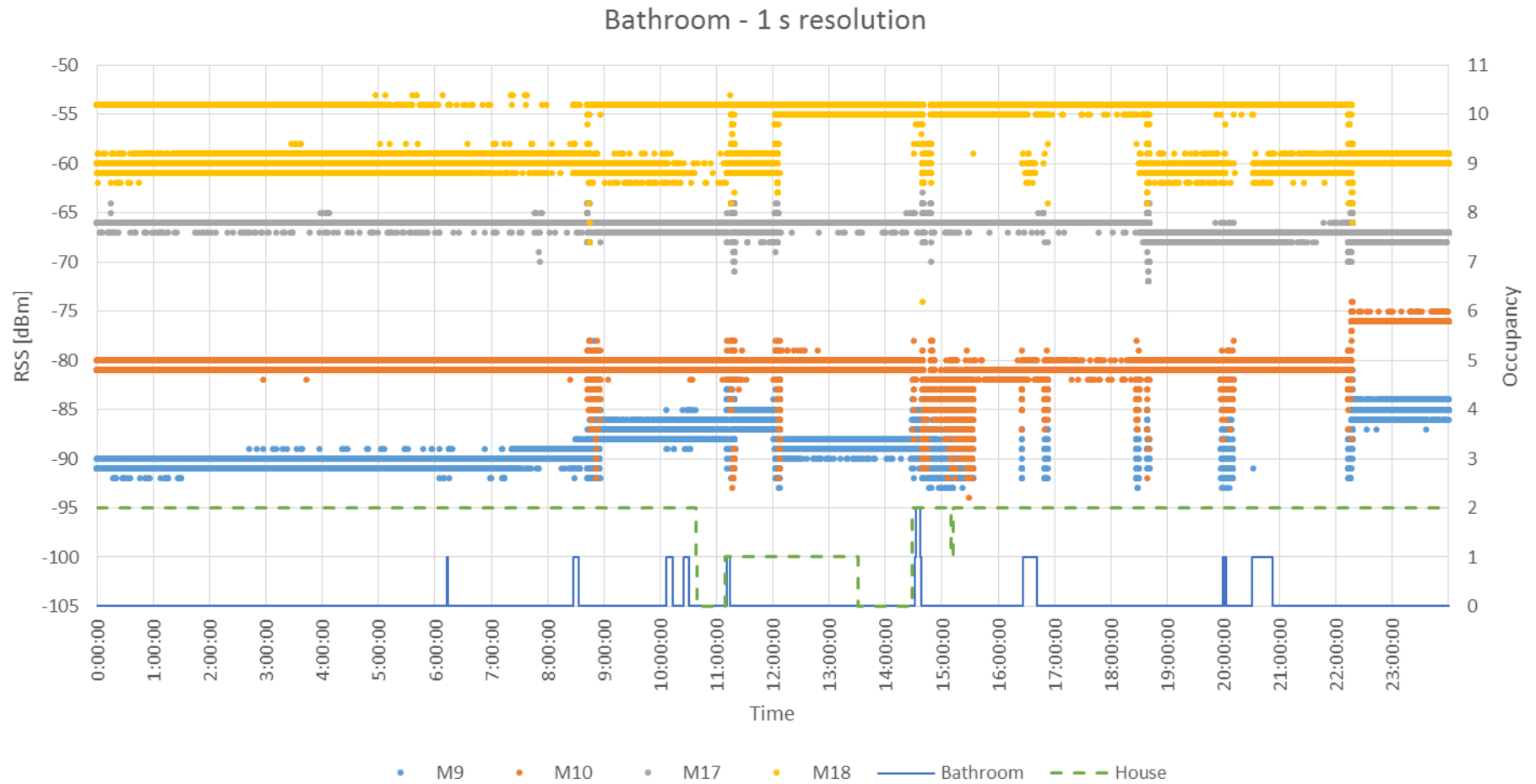

FIGURE 9-7: RSS RESPONSES TO BATHROOM OCCUPANCY AT ONE SECOND RESOLUTION

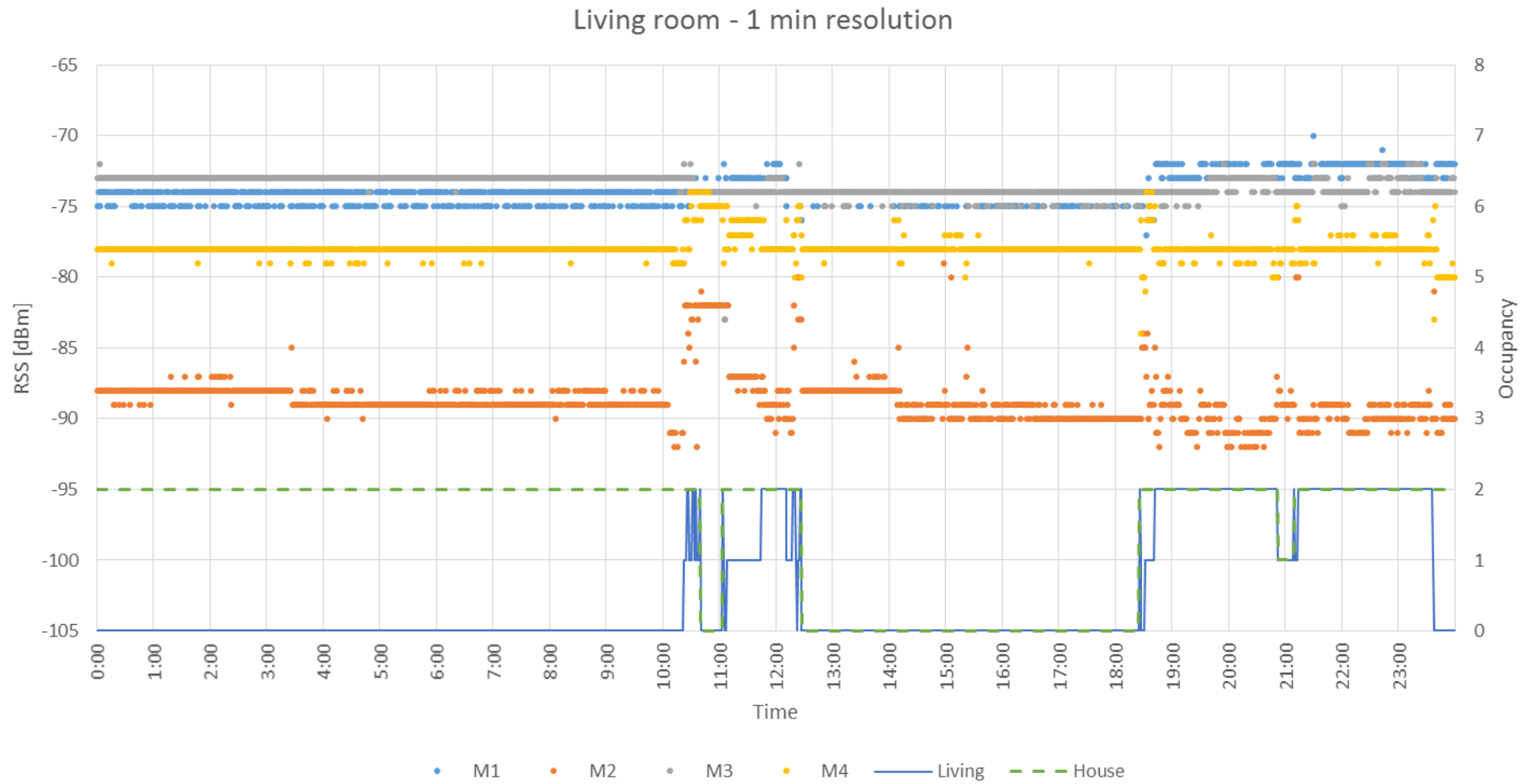

FIGURE 9-8: RSS RESPONSES TO LIVING ROOM OCCUPANCY AT ONE MINUTE RESOLUTION

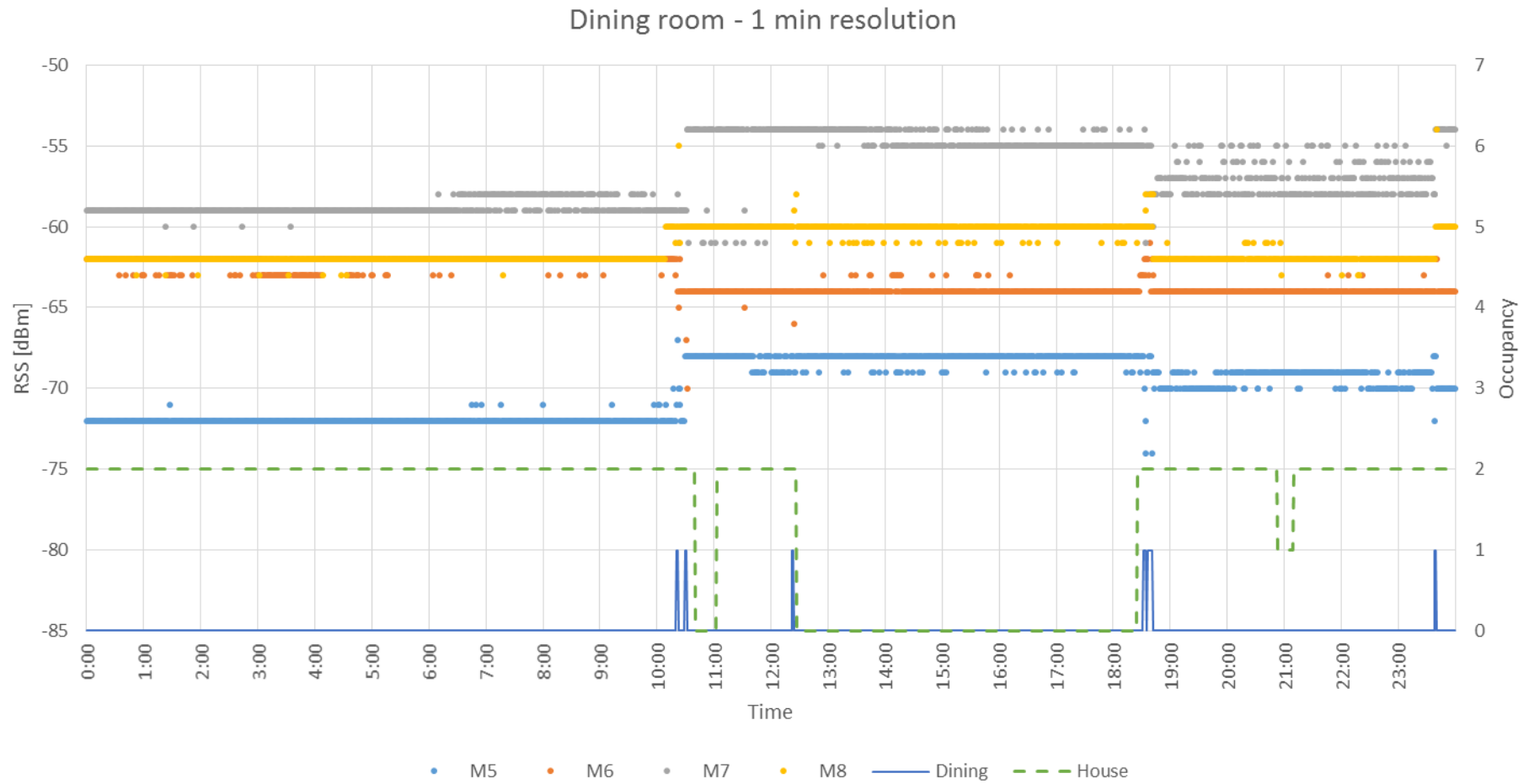

FIGURE 9-9: RSS RESPONSES TO DINING ROOM OCCUPANCY AT ONE MINUTE RESOLUTION

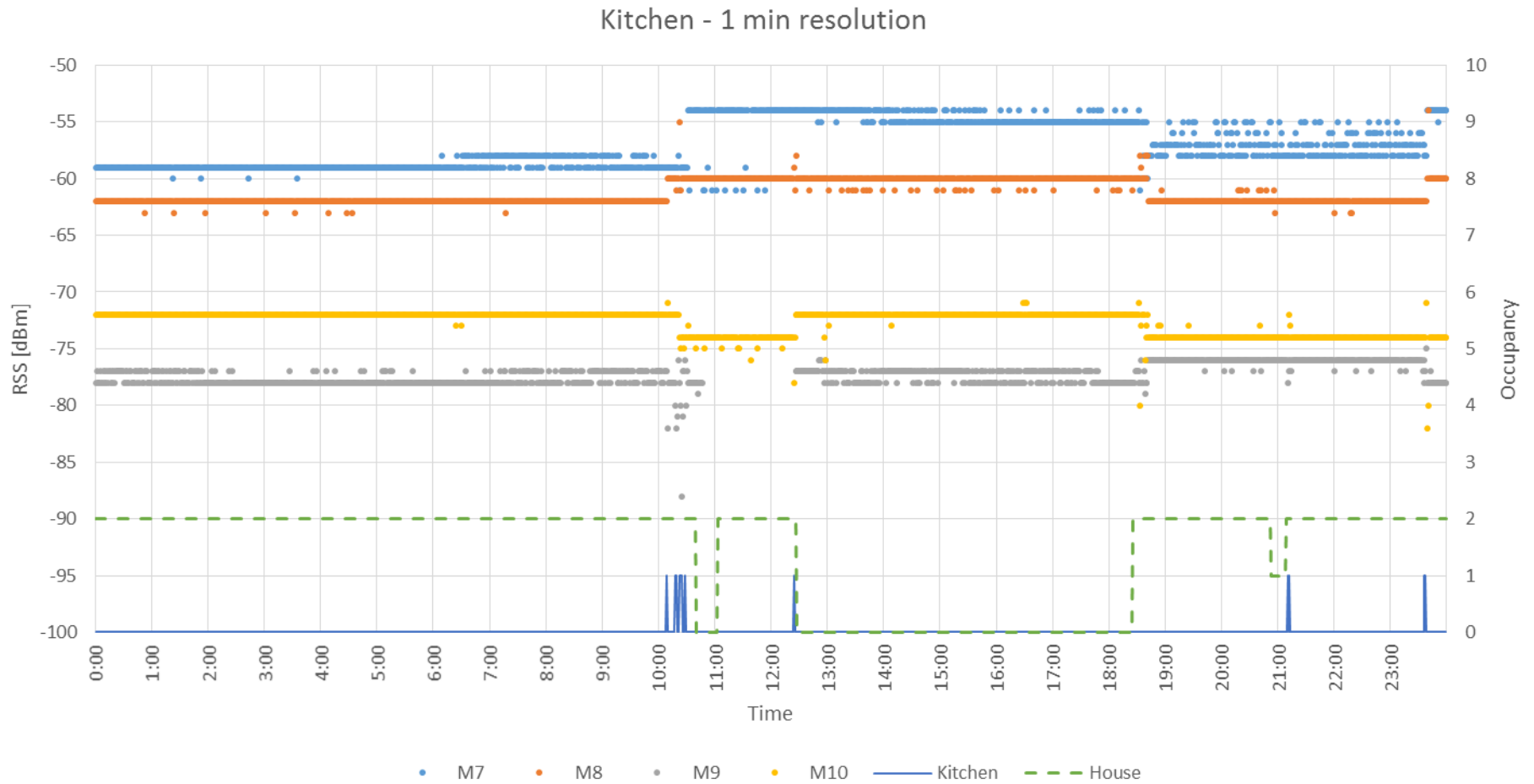

FIGURE 9-10: RSS RESPONSES TO KITCHEN OCCUPANCY AT ONE MINUTE RESOLUTION



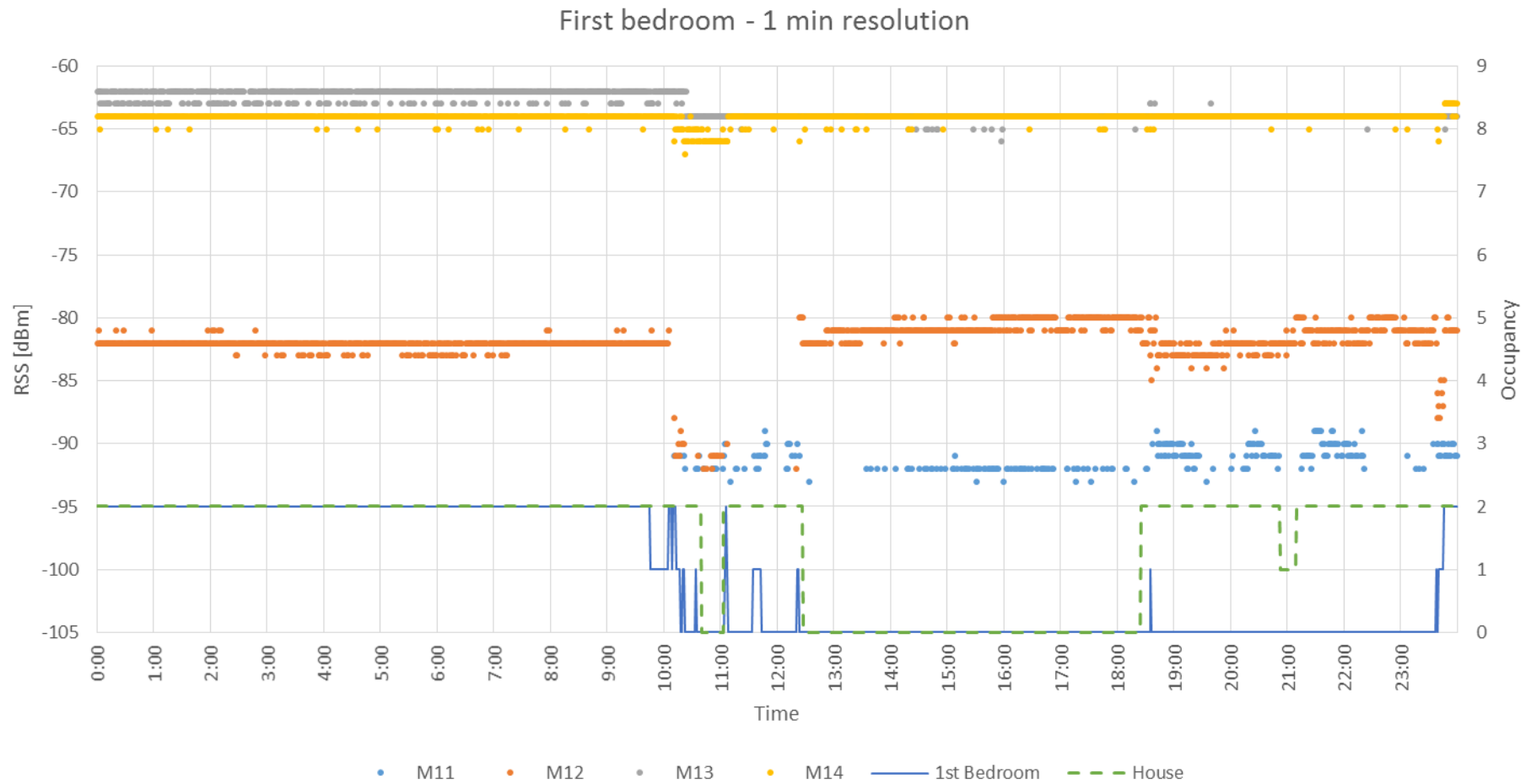

FIGURE 9-11: RSS RESPONSES TO FIRST BEDROOM OCCUPANCY AT ONE MINUTE RESOLUTION

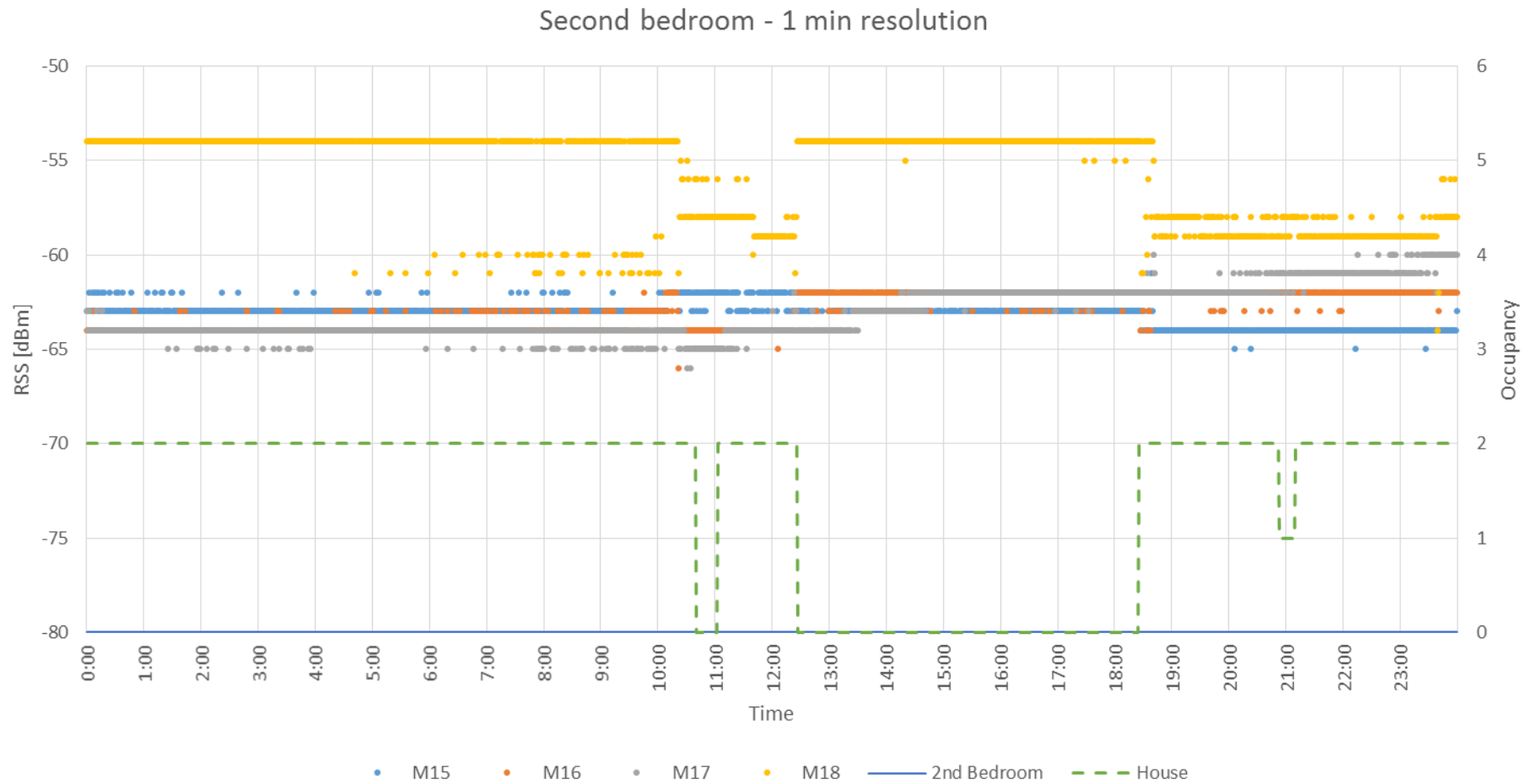

FIGURE 9-12: RSS RESPONSES TO SECOND BEDROOM OCCUPANCY AT ONE MINUTE RESOLUTION

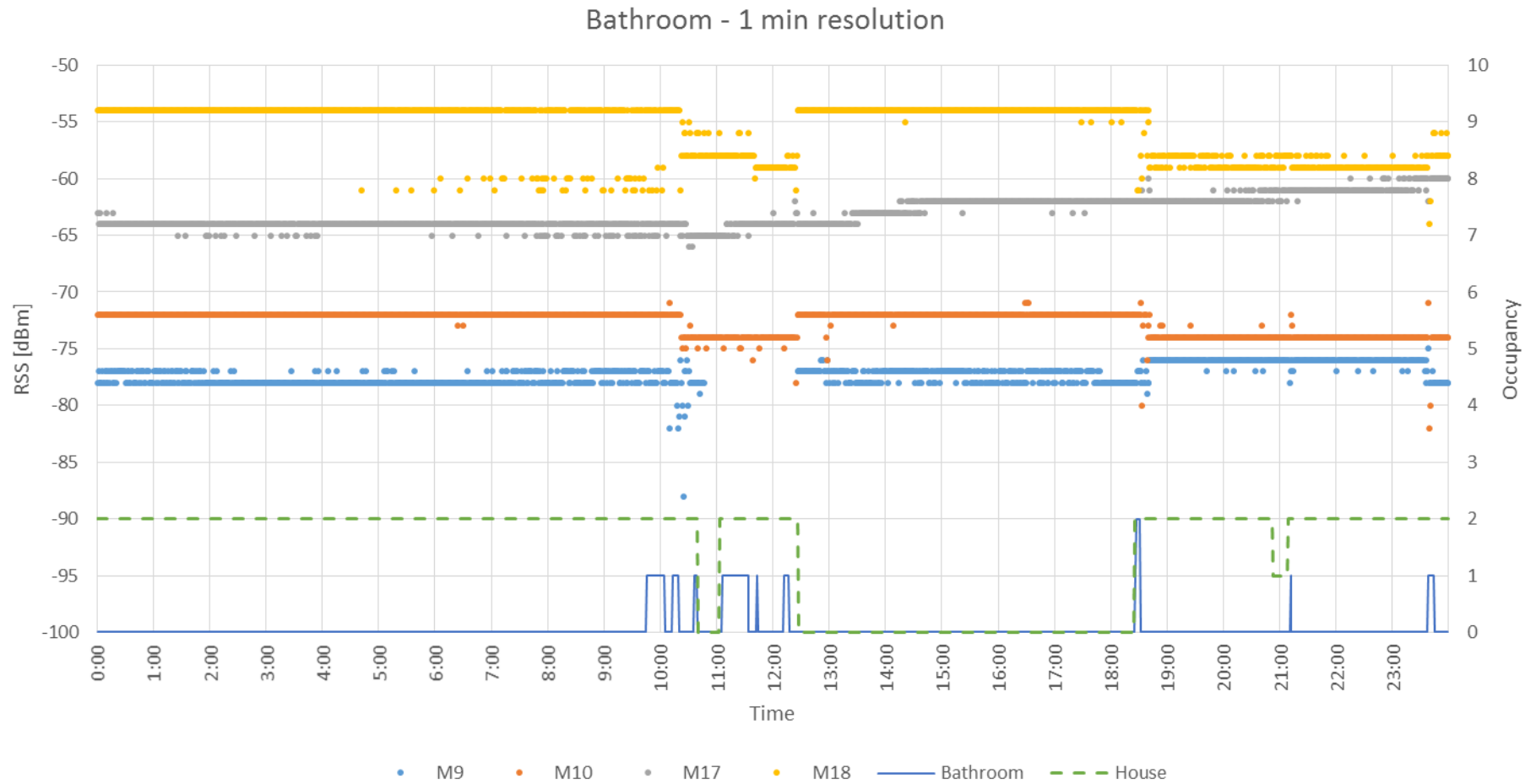

FIGURE 9-13: RSS RESPONSES TO BATHROOM OCCUPANCY AT ONE MINUTE RESOLUTION

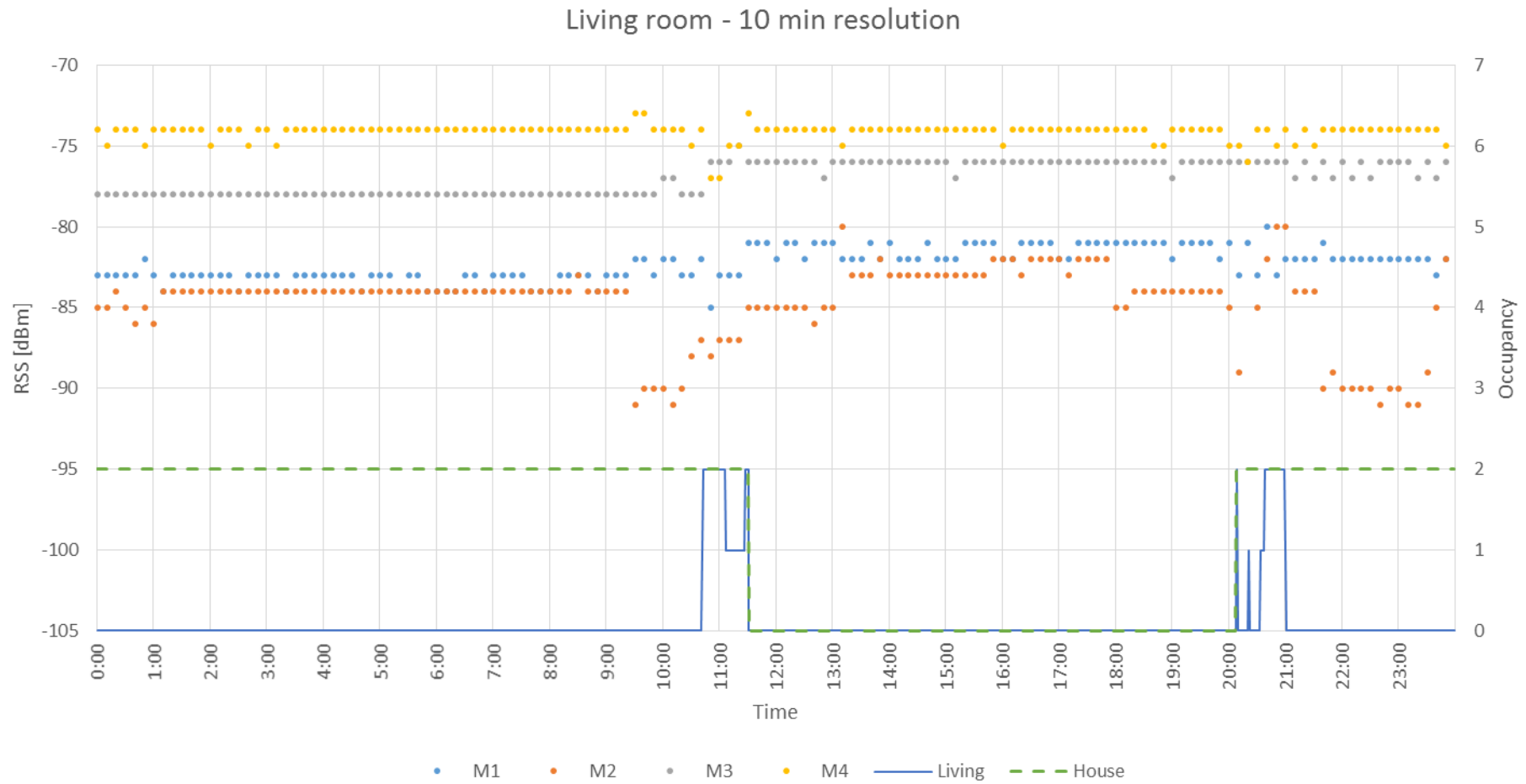

FIGURE 9-14: RSS RESPONSES TO LIVING ROOM OCCUPANCY AT TEN MINUTE RESOLUTION



FIGURE 9-15: RSS RESPONSES TO DINING ROOM OCCUPANCY AT TEN MINUTE RESOLUTION

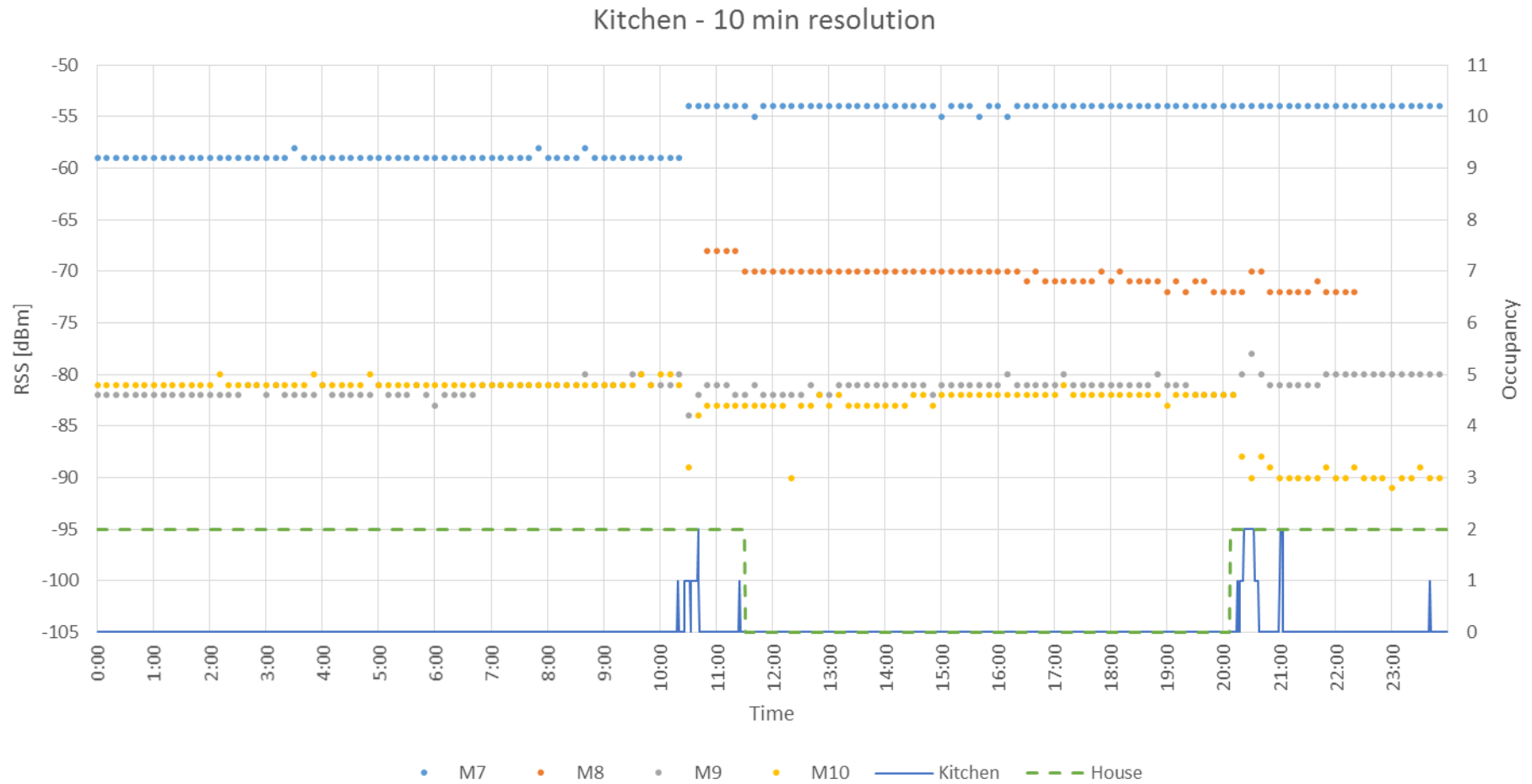

FIGURE 9-16: RSS RESPONSES TO KITCHEN OCCUPANCY AT TEN MINUTE RESOLUTION

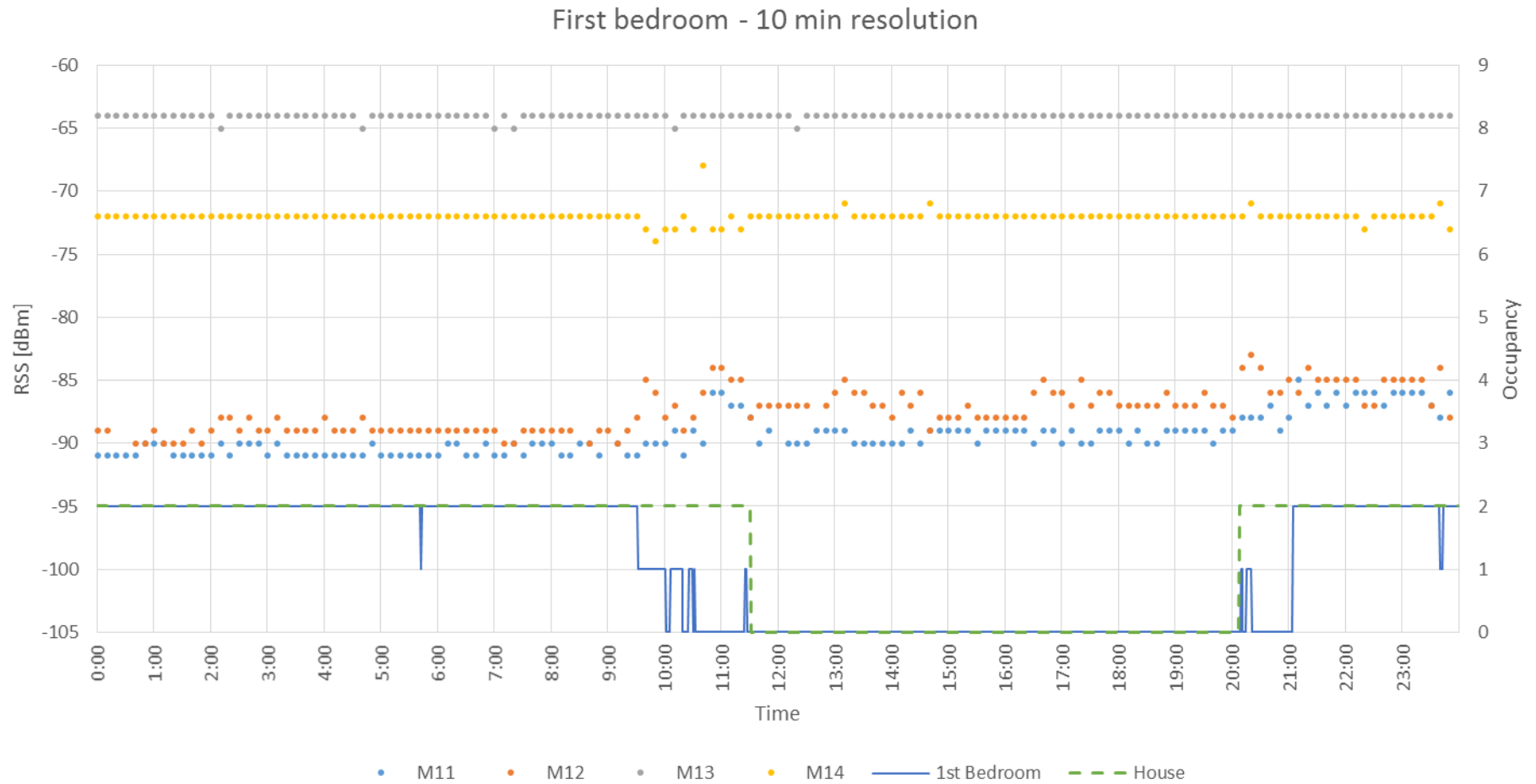

FIGURE 9-17: RSS RESPONSES TO FIRST BEDROOM OCCUPANCY AT TEN MINUTE RESOLUTION

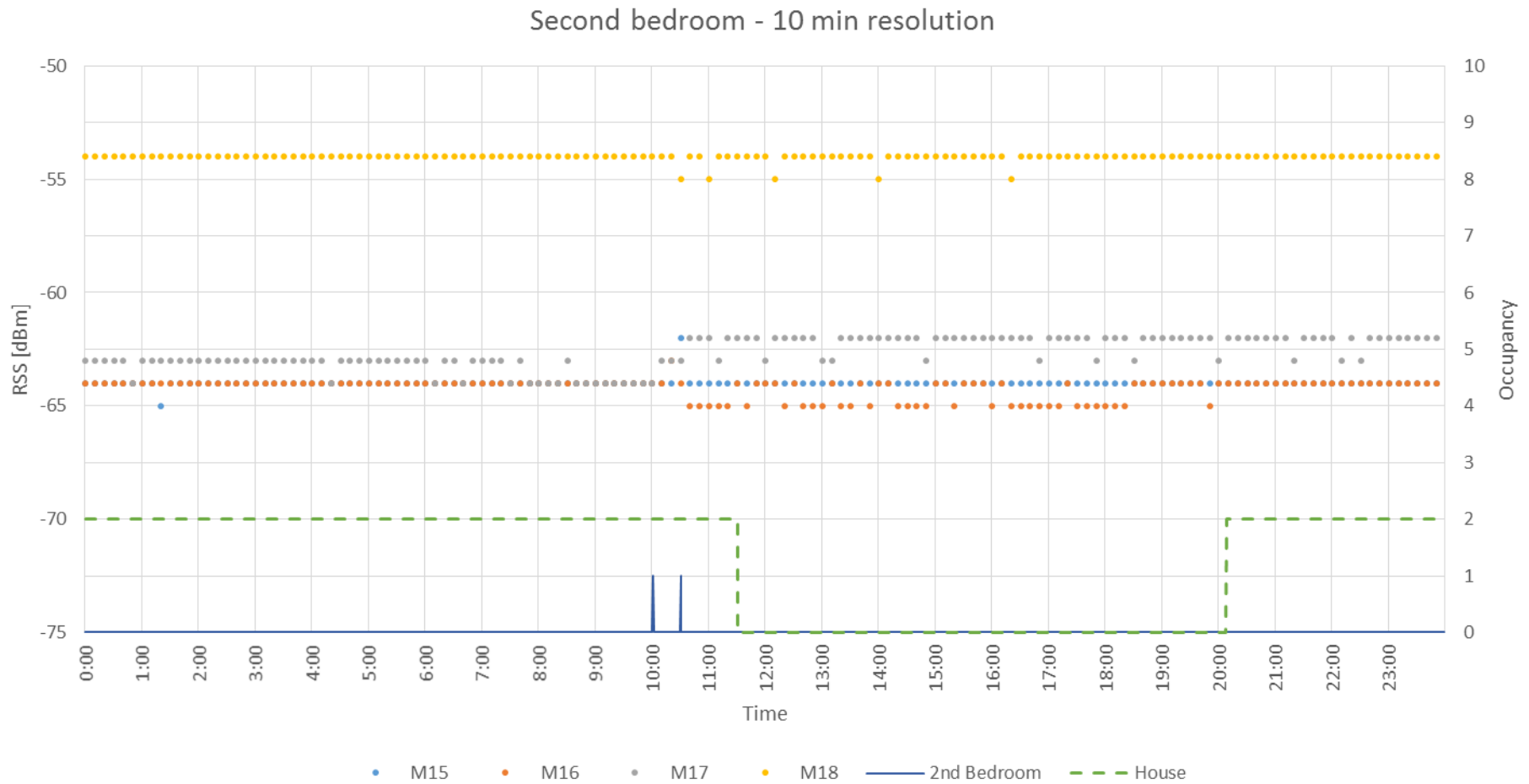

FIGURE 9-18: RSS RESPONSES TO SECOND BEDROOM OCCUPANCY AT TEN MINUTE RESOLUTION



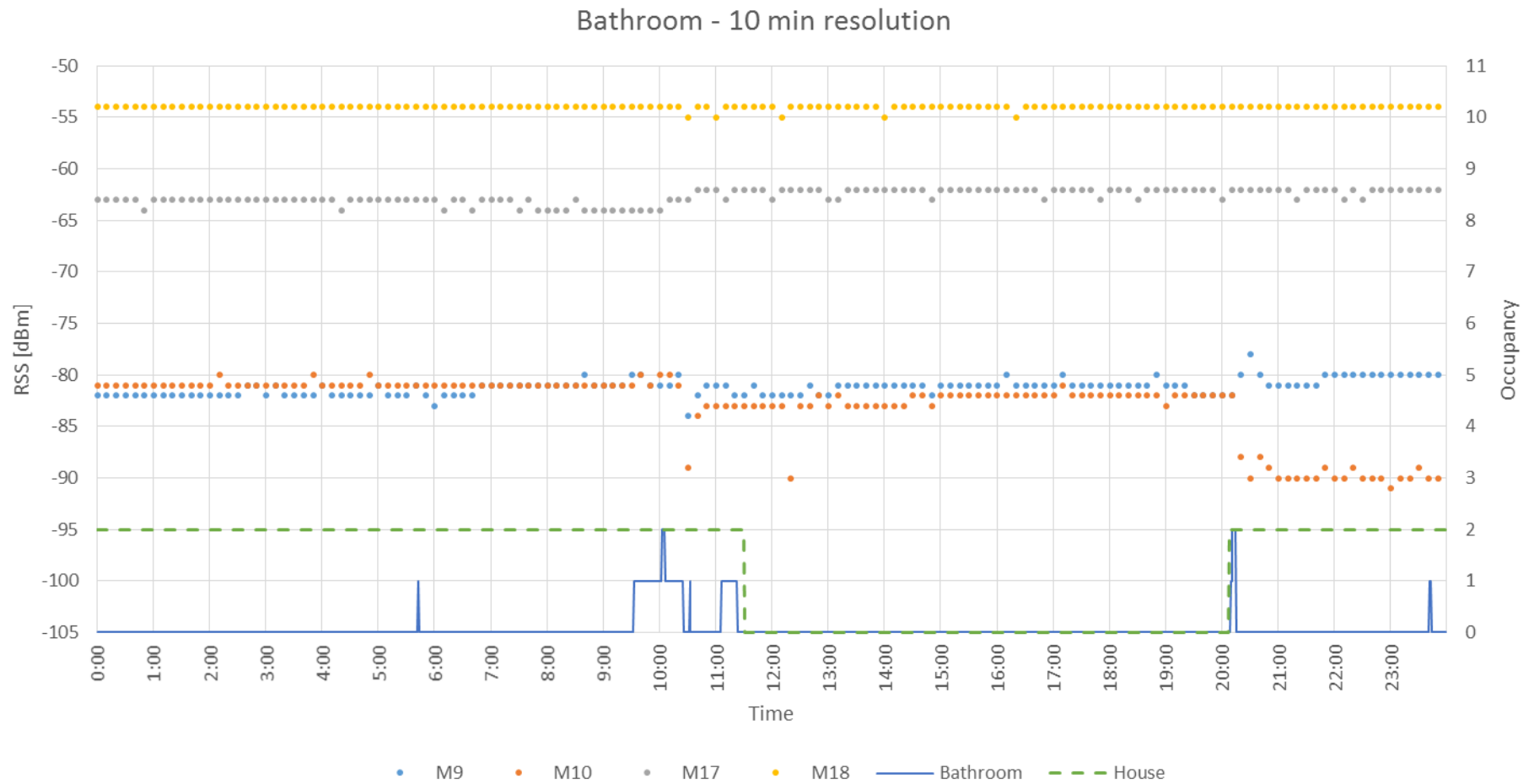

FIGURE 9-19: RSS RESPONSES TO BATHROOM OCCUPANCY AT TEN MINUTE RESOLUTION

### 9.2.3 DISCUSSION

The results seemed to suggest that the 1 s resolution represented the occupancy pattern the most accurately and that the 10 min resolution did so the least accurately. However, as mentioned in section 9.2.2, during the 1 s resolution test several measurements were not recorded. This could have been caused by the overwhelming amount of packets sent to M0, which in turn could have created a bottle neck effect. Some motes' packets, most notably M9's, only seemed to reach the RX if other motes' packets failed to do so. Hence, the temporal resolution should be adjusted in accordance with the number of TXs per RX in order to avoid this effect.

Additionally, during the experiment, the reception of RSS values of individual motes was the sole method to identify whether their batteries were still functional. Besides implementing other methods, it should be ensured that motes do not operate at the lower end of their sensitivity range with the monitored area being empty, as this could lead to an increased amount of lost packets during occupancy.

Furthermore, it was noticed that the batteries discharged themselves more quickly during the 1 s resolution test. Also, it can be assumed that the processing power required to manage the data was linear to the amount of data collected. With regards to applying DfL to an energy saving COAC system, it would be counterproductive if the associated DfL was excessively consuming energy. Hence, the 1 s resolution was probably disproportionately fine grained for a domestic application.

On the other hand, the 10 min resolution was not informative enough for domestic occupancy patterns. Many occupancy periods or movements by the occupants were not or barely represented.

In fact, for all three resolution scenarios the movement of occupants created more distinctive RSS response patterns than their presence alone, which supports section 7.5's findings. RSS decreases due to presence were not consistent, especially with respect to periods when the house was unoccupied. However, the RSS distribution of the links seemed to spread with movement, which supports section 8.4's suggestion to employ it as an analysis method.

Furthermore, RSS variations during unoccupied periods were recorded. This could suggest that activity in the adjoined terrace house or outside the property was monitored. However, section 8.6 could not identify a person's movement behind a series of radio links in an outdoor setting. Section 6.5 on the other hand, demonstrated that human presence was measurable behind the LOS of a radio link in an indoor setting. Both experiments had a radio link length of approximately 2 m, but the person was 1 m away in the former and immediately behind in the latter. Hence, one amongst several explanations for the variations in RSS during unoccupied periods could be that the distance between TX and RX dictated the area which can be monitored behind either of them, and hence other people's movements were recorded. Another explanation could be that variations in the atmosphere, such as temperature and humidity, changed the relative permittivity of materials inside the house, which affected their signal related properties, as described in section 5.2, and hence RSS variations were due to signals following new paths.

Conclusively, the one minute resolution appeared to be the best compromise between accuracy of monitoring and energy efficiency. However, as the occupancy patterns demonstrated, often only a small fraction of a day actually required active monitoring. Hence, non-deterministic methods could be employed to adapt the resolution dependent on activity levels. Obviously, the temporal resolution required by the COAC system would also need to be considered.

#### 9.2.4 CONCLUSION

The experiment demonstrated that the temporal resolution setting of DfL needed to compromise between occupant detection accuracy and energy efficiency. Out of the three resolutions tested, the minutely time intervals seemed to be the closest appropriated deterministic setting for a domestic environment. However, the use of non-deterministic monitoring methods was suggested, which could adapt the resolution to activity levels whilst respecting the requirements by the COAC system.

The experiment also confirmed that occupancy could be monitored in a two bedroom end of terrace house and that movement rather than presence caused variations in RSS, which supported a

suggestion made in a previous experiment to use RSS distribution as a DfL analysis method. Furthermore, recommendations with regards to network design and operation were made, which included that the numbers of TXs per RX should be adjusted to avoid bottle neck effects and that radios should not be operated at the lower end of their sensitivity range to avoid lost packets during occupancy monitoring.

### 9.3 CHAPTER CONCLUSION

Part C of the comprehensive study applied DfL to a realistic domestic setting and investigated its optimal temporal resolution. This experiment concluded the series, which established the potential of DfL in the context of a COAC application. A variety of technical aspects, including DfL's ability to detect, localise and track occupants, were established. Also, implementation guidelines, concerning network design, layout and operation, were developed. However, besides the technical facts, occupants' perceptions influence whether such a combination of DfL and COAC system could prove a realistic solution to domestic energy efficiency. Hence, chapter 10 investigated the views and acceptance levels of potential users.

## **10 USER PERCEPTION**

### **10.1 INTRODUCTION**

The concept of applying DfL to COAC was outlined in chapter 3, and chapters 6 to 9 have demonstrated DfL's technical abilities. However, for the adoption of DfL in the context of domestic energy saving control methods, the acceptance level by potential users, as well as their associated motivations, need to be considered and understood. For example, the potential for health and security concerns with regards to DfL were highlighted by chapter 5. Hence, a questionnaire study was conducted to investigate the public's perception of occupant control and automation control methods, as well as of the domestic application of DfL.

### **10.2 METHODOLOGY**

An online questionnaire was designed based on the literature reviewed in chapters 3 and 5.

Initially, besides demographic information, the questions sought to establish the participants' current energy saving behaviours and related incentives. Thereafter, the questions focused on the participants' views with regards to potential occupant and automation control methods. Due to the interface issues outlined in section 3.3.3, the participant's relations to automation control systems, particularly their notion of trust, were examined.

After introducing the concept and application of DfL, the questionnaire assessed participants' acceptance levels of domestic tracking. Additionally, the health concerns, discussed in section 5.4, were evaluated in relation to existing electromagnetic technologies, such as Wi-Fi. Against convention, the statement based questions were designed in a non-alternating style as Sauro and Lewis [140] suggested that the same results would be yielded and that participants as well as researchers would have less difficulties to handle them.

Furthermore, to identify security concerns, which were also outlined in section 5.4, the participants were asked questions about the collection and accessibility of data produced by DfL.

Finally, the participants' interests in owning a potential energy saving system based on DfL, were investigated.

After an initial draft of the questionnaire was designed, it was piloted sequentially with five different people; most of whom had previous experience with questionnaires. The suggestions which were implemented, were highlighted and explained below.

The first reviewer suggested to:

- improve a multitude of wordings throughout the questionnaire
  - Besides fixing some spelling mistakes, this also prevented some of the questions from being leading.
- use a multiple answer style question when asking about motivations for saving energy
  - This suggestion was implemented by adding the choice of "both options equally" to represent people who are encouraged by environmental and financial incentives equally.
- add the choice of "occasionally" when asking the participants which specific energy saving measure they would do themselves
  - Not only did that add depth to the question by requiring the participant to further think about their choice, it also allowed better comparison with the automated counterpart question.

The second reviewer suggested to:

- expand on the manual or automated energy saving measures, by giving specific examples
  - This helped to give participants a clearer image of the questions they were asked.
- separately ask whether participants would prefer tag-based or tag-less tracking

- Besides making the statement questions more coherent, it improved the ability to interpret participants' views on DfL data collection.
- include the option of "nobody" to the question asking who the data should be visible to
  - This option was required to cover all possible responses.
- instead of questioning the expected savings in relation to their energy bill, ask: "How many years would the payback period of such a system need to be for you to consider purchasing it?"
  - The suggested question did not require further information and put the savings in direct relation to the investment, which was expected to facilitate analysis of the results.

The third reviewer suggested to:

- increase the options from "yes", "sometimes" and "no" to a five point Likert scale, when asking the regularity of energy saving measures taken
  - In addition to introducing greater differentiation, this suggestion led to the rephrasing of the original question, as the term "regularly" was leading.
- ask participants whether they think energy is expensive
  - This question was required to help contextualise participants' choices.
- further explain the link between the suggested DfL technology and automation control systems
  - The context in which the questions were being asked required clarification.

The fourth reviewer suggested to:

- simplify the wording of several parts of the survey
  - This improved the legibility and accuracy of the questionnaire.

The fifth reviewer suggested to:

- ask demographic related questions at the end of the questionnaire
  - This allowed participants to be confronted quicker with the actual matter of the questionnaire and a relationship was established before personal information was requested.
- adjust the age bands to differentiate the older age groups better
  - The initial age bands were designed with the expected respondents' age groups in mind rather than the actual population. This opportunity was also used to change the age group selection into a drop-down menu to ease the view of age sensitive participants.
- make it clearer to participants that they were asked to answer both sets of questions relating to energy savings measures, the ones they do themselves and the ones they would let an automated system handle
  - Comment sections were introduced for the "...do yourself" and "...let an automated system handle" sections to clarify that both sections needed to be answered, which also providing greater insights into the participants' answers.
- replace the energy saving measure: "only heat the hot water tank when necessary", as some people might have combination boilers
  - This energy saving measure was replaced by "turn the heating off/down when you go on holiday" to increase the applicability to participants.

The sixth and final version of the questionnaire, as presented in appendix B, was submitted for an ethics review to the Faculty of Engineering Ethics Committee. With their approval, it was advertised and distributed online using several channels, such as the Graduate School's newsletter, University internal email listings and social media.



### 10.3 RESULTS

The initial number of 50 expected participants was reached very rapidly and hence the limit of respondents to the online questionnaire was increased to 100. Consequently, 89 people completed the questionnaire of whom 42 were female and 47 male. More than 50 percent of participants were aged between 18 and 25. The second largest group were the 26 to 35 year old with 29.2 percent. The age groups, 36 to 45, 46 to 55 and 56 to 65 were represented with 8, 6 and 1 participants, respectively. Approximately 80 percent of the respondents were students and 20 percent professionals.

All types of accommodation were represented, with approximately two thirds being rented. 28.1, 19.1, 29.2 and 20.2 percent lived respectively in a "Flat / Apartment", "Terraced House", "Semi-detached House" and "Detached House". 3.4 percent lived in a "Bungalow". The majority, with 25.8 percent, lived with one other person. 16.9 percent of participants lived with three people, 14.6 percent lived with two people and 12.4 percent lived either alone or with four or five people. The remaining 5.6 percent of participants lived with more than five people. 48 participants knew the approximate age of their accommodation, which covered a wide range. 10 participants stated that their houses were more than 100 years old, 14 that theirs were between 50 and 100 years old, and 24 stated that they lived in houses less than 50 years old.

With regards to current energy prices, the majority with 61.8 percent thought that they were expensive or very expensive. 36 percent of participants judged them as averagely priced and 2.2 percent as cheap.

80.9 percent reported to take energy saving measures very often or relatively often, 18 percent stated to take them sometimes and one participant said to never take them.

The cross tabulated responses of perceived energy prices and energy saving measures were represented in figure 10-1.

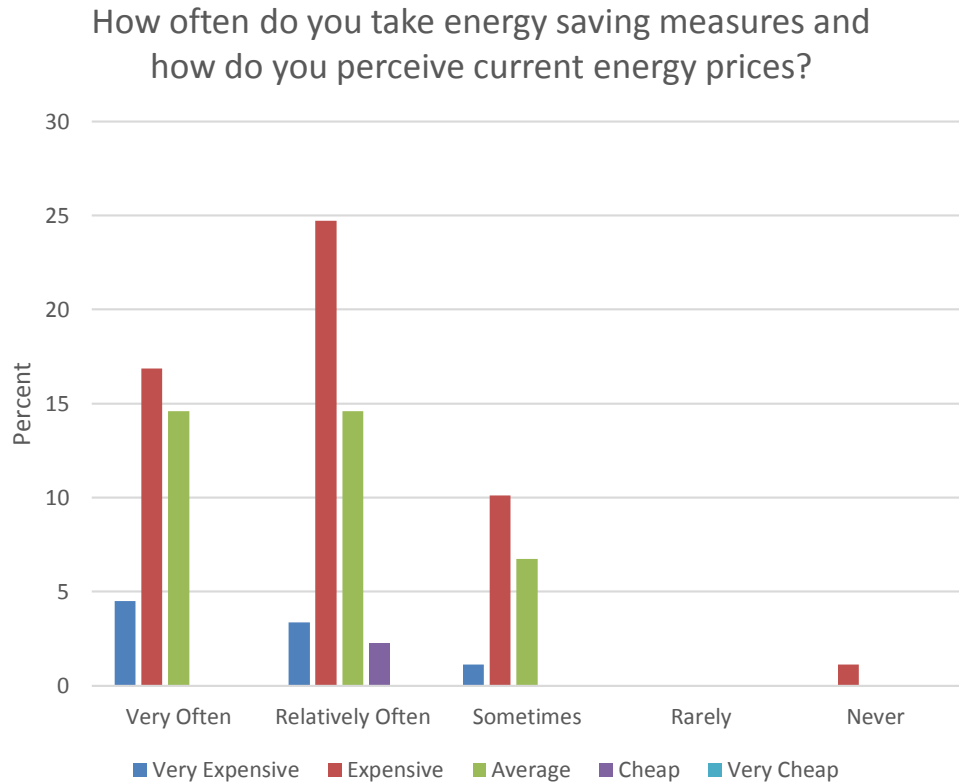

FIGURE 10-1: PERCEIVED ENERGY PRICES IN RELATION TO REPORTED ENERGY SAVING MEASURES TAKEN

The question “what encourages you foremost to save energy?” was answered by 14 participants with “protect the environment” and by 35 participants with “reduce energy costs”. 36 participants were motivated by both options equally. The remaining 3 participants explicitly highlighted that their moral values encouraged them to save energy and that waste in itself was “silly”. The person, who previously stated to never take energy saving measures, ticked the “other” option and entered “not applicable”.

The question whether participants would let an automated system handle potential energy savings in their house, was answered by 40.4 percent with “yes”, by 50.6 percent with “depends” and by 9 percent with “no”. The comments, which some participants left, were listed in table 10-1 along with their chosen response.

In general, would you let an automated system handle potential energy savings in your house?

Response	Comment
Yes	<p>"It is easier"</p> <p>"Smart meter"</p> <p>"I trust in mec."</p> <p>"It would be more reliable."</p> <p>"Would help to reduce energy output even when people forget."</p> <p>"Because I care about the environment but others don't. It would make up for their laziness."</p> <p>"Allows management of systems even at night when I'm asleep and could follow temperatures automatically and accommodate."</p> <p>"I already use some automated systems, like plugs that switch off my TV and PC completely when not on as well as all the peripherals connected to it."</p> <p>"Then there would be a single unit to do it, removing human error and the mutual assumption that another person in the house has turned the lights off etc."</p>
Depends	<p>"Yes if it was reliable"</p> <p>"Will it work and benefit me."</p> <p>"Don't like the idea of being tracked"</p> <p>"Depends if I had overall power etc."</p> <p>"If it was proven to work and cut costs"</p> <p>"Automated system has less user control"</p> <p>"As long as it doesn't fail to increase my bills"</p> <p>"Depends on the reliability of such a system"</p> <p>"Depends which things it took control over..."</p> <p>"Depends on the level of control I would have over it"</p> <p>"Need to see proof and need to know what it will do."</p> <p>"Only if I could customise it myself or at least view how it works"</p> <p>"Depends on the balance in control between the person and the system"</p> <p>"Automated systems are never quite as convenient as you think they will be"</p> <p>"As long as it's well designed and allows the user to control how it is set up."</p>

	<p>“If it was trustworthy and maybe if it gave online feedback about savings”</p> <p>“I would like to customise it as day to day weather and calendar events are never the same.”</p> <p>“...on the cost of ownership against the potential surge of energy price in the future.”</p> <p>“How customisable this was. Would not like additional hardware; computer software would be ideal.”</p> <p>“Some user input is needed. Need some kind of real time assurance on what is being done...i.e. SMS messages when the heating is being switched off. Also to be truly efficient and comfortable you would need it to work around the users requirements...elderly usually need to be kept warmer. Etc...”</p> <p>“To an extent I already do with the lights in the living room; a hacked-together heath-robinson contraption based on hardware designed to manage servers. I would be willing to if, and only if, I could examine what the system was actually /doing/ and why - open source is a start, but producing good logs and being a good network citizen is important too.”</p>
<p>No</p>	<p>“Prefer to have control”</p> <p>“Do not trust automated systems”</p> <p>“I wouldn't want it turning off things I want to be on”</p> <p>“I do just fine - automated systems will be based on norms – I’m a human”</p> <p>“Cause I don't trust it, we should not waste our time on green building technologies. Instead we should focus on developing building technologies against severe weather or even natural disaster.”</p> <p>“Extra cost plus maintenance cost will be required and if there are technical problems I will need to pay for someone to fix it so over all there are a lot of extra cost.”</p>

TABLE 10-1: COMMENTS RELATED TO WHETHER PARTICIPANTS WOULD LET AN AUTOMATED SYSTEM HANDLE POTENTIAL ENERGY SAVINGS IN THEIR HOUSE

The question “Do you generally trust automated systems to make the right decisions?” was answered by 30.3 percent with “yes”, by 52.8 percent with “depends” and by 16.9 percent with “no”. The comments that some of the participants added to their choices were listed in table 10-2.

Do you generally trust automated systems to make the right decisions?	
Response	Comment
Yes	<p>"More accurate than humans"</p> <p>"I trust technology, its usually pretty logical!"</p> <p>"But I would like always to have control over the settings."</p> <p>"Systems only do what they are told. Problems can easily be adjusted."</p> <p>"But it should have some particular settings when saving is unnecessary."</p> <p>"Generally any faults are in the person who sets it up so if it is done right your fine"</p> <p>"Most of the time I can see how simple sensors can make the right decisions. But there is a question about whether the sensors need energy to run themselves and if it makes no difference in the end. Unless there is another way of using automated systems?"</p> <p>"If a programmed automated system is simple enough it is less likely to fail than a complicated busy person. And automated systems don't fall asleep on the couch or pop out to the shop for milk and take a detour to the pub. Basically an automated system is designed to do a job, people have lives."</p>
Depends	<p>"Not always reliable"</p> <p>"Never encountered one"</p> <p>"Not sure! Never tried one"</p> <p>"On accuracy of the system"</p> <p>"If can override as necessary"</p> <p>"Depends on electrical system"</p> <p>"Knowledge and experience of system."</p> <p>"Depends on the reputation of the developer"</p> <p>"If the said automated system is proven to be reliable."</p> <p>"The automated windows at work don't work very well."</p> <p>"...on its sensitivity for use and reliability over its lifespan."</p> <p>"They fail sometimes so I'm cautious not to let work all by itself"</p> <p>"The system they use to determine the conditions, e.g. if the TV is being watched."</p> <p>"Depends on the past performance of the system - I wouldn't automatically trust it."</p> <p>"They don't have the capability to know why I've made a decision, so they can't replicate it"</p>

	<p>“If I want for example the bathroom warm, because I know I will be taking a bath in an hour and the system only "measures" if someone is there the system wouldn't work right.”</p> <p>“Not currently, e.g. systems to switch off peripheral devices when PC is shutdown still leave PC connected and some PCs use around 50w when shutdown so need to be disconnected too.”</p>
<p>No</p>	<p>“Bad experiences - liable to failure”</p> <p>“As I said, I don't trust it, unless I did the design.”</p> <p>“No artificial intelligence is 100 percent reliable.”</p> <p>“Again, an automated system will be based on norms - I want autonomy over my environment”</p> <p>“They tend to not have flexibility to make case by case decisions”</p> <p>“How can they know exactly what I want when I don't even know what I want!”</p> <p>“They do not understand human behaviour and intentions enough to make anything but the most simple decisions.”</p> <p>“Don't trust, but would be willing to make 'take the plunge' and use one because it is a good idea. If it was marketed as a product in beta testing, then consumers wouldn't need to trust it.”</p> <p>“I am a professional software developer; I used to run a massive internet-connected network, and I've written power management systems for datacentres. Comparatively, those are simple, and even *those* were nearly impossibly difficult to get right. I have never yet met an automated system that was consistently correct - it's more important that a potential bad decision can either be cleaned up after nicely or forestalled before the event. As said, good citizenship with regards to other devices is vital.”</p>

TABLE 10-2: COMMENTS RELATED TO WHETHER PARTICIPANTS GENERALLY TRUST AUTOMATED SYSTEMS TO MAKE THE RIGHT DECISIONS

The responses to the questions whether the participants would “let an automated system handle potential energy savings” and whether they would “generally trust automated systems to make the right decisions” were cross tabulated in figure 10-2.

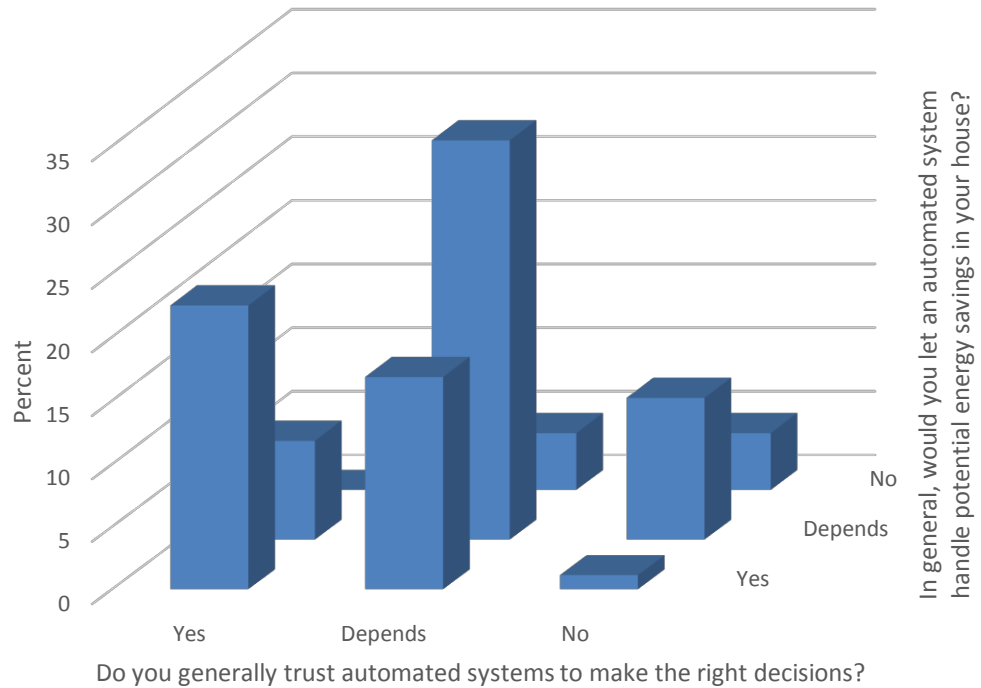

FIGURE 10-2: PERMISSIONS TO LET AUTOMATED SYSTEMS HANDLE ENERGY SAVINGS IN RELATION TO TRUST

The responses to the question which type of energy saving measures the participants would do themselves or let an automated system handle, were presented in figure 10-3. Also, some associated comments were selected and highlighted in table 10-3.

Which type of energy saving measure would you...

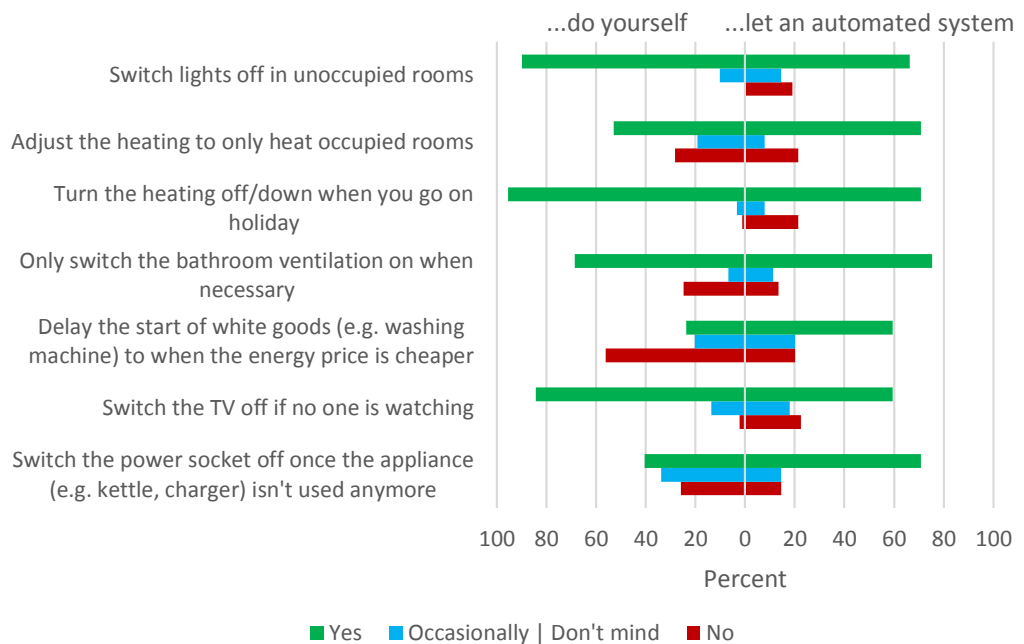

FIGURE 10-3: PREFERENCES WITH REGARDS TO OCCUPANT AND AUTOMATION CONTROL MEASURES

CHAPTER 10: USER PERCEPTION

Which type of saving would you...	...do yourself	...let an automated system handle
a) Switch lights off in unoccupied rooms	"Only if the room will not be occupied again in less than 5 mins."	<p>"I don't like it when motion sensors turn the lights off when I'm in a room - especially in loos - which happens a lot."</p> <p>"It uses energy too."</p> <p>"For some of my roommates."</p> <p>"If I've left the light on, it's for a reason."</p> <p>"But line-of-sight is important - sometimes I need the hall light on to maintain the light level in the *living room* at an acceptable level."</p> <p>"Would just cause problems."</p> <p>"Though would want to override for some rooms and times."</p>
b) Adjust the heating to only heat occupied rooms	<p>"Central heating system without individual control."</p> <p>"Well, the radiators only exist in bedrooms."</p> <p>"Old house that can get damp in unheated rooms."</p> <p>"Heating is manual in our house."</p> <p>"Heating changes are not instant so this has limited effect if you frequently move from room to room."</p>	<p>"I want to decide the heating in my rooms."</p> <p>"Wouldn't be warm moving from one room to another."</p> <p>"Providing it could be regulated."</p> <p>"The system has no way of knowing what room I'm likely to inhabit /next/ - I turn heating on in rooms based on my prospective movements, not on my current location!"</p>
c) Turn the heating off/down	<p>"Central heating system without individual control."</p> <p>"I will check everything off before I go for a long trip."</p> <p>"Is there anyone so stupid that let the heating ON when he go on holiday?"</p>	<p>"Would be useful if left on unintentionally."</p> <p>"How the system can tell I am on holiday?"</p> <p>"Don't want it to know where I am."</p>



CHAPTER 10: USER PERCEPTION

<p>when you go on holiday</p>	<p>“Yes in summer, but will leave on low thermostat setting in winter to stop pipes from freezing.”</p>	
<p>d) Only switch the bathroom ventilation on when necessary</p>	<p>“I don’t have the option of doing this.”          “Well, there is only natural ventilation in my bathroom.”          “We have to leave it on when we leave the bathroom then we forget to go in and turn it off later.”          “Already on a timer connected to light.”</p>	<p>“Maybe - depends on whether it's reliable enough.”          “Suggested to be off 3-5 minutes later automatically.”          “It should turn on for 20 minutes after bathroom light is switched off.”          “We have this but humidity sensor is too sensitive even in its minimum position so don't use. Would use if it worked properly.”          “I decide what necessary is based on how I feel - sometimes I like it to be hot in the shower - sometimes I like a window open when I have a shower to cool down.”</p>
<p>e) Delay the start of white goods to when the energy price is cheaper</p>	<p>“May involve a long wait.”          “Washing machine is too noisy to have on at night.”          “We don't have a specific price for the time at which we use energy.”          “I have a timer so I can set the washing machine to wash in the middle of the night which I do occasionally.”          “I do turn them on during off-peak hours sometimes.”</p>	<p>“Needs to fit with days plans.”          “A washing machine at night may be too noisy to sleep.”          “Maybe an automated system could alert you when is best?”          “Don't like washing machine/dishwasher coming on when I am out or asleep in case of leaks.”          “If it was relevant to our energy prices, and if it could be overridden so for example you need to put the dishwasher on in the day.”          “Energy prices might be cheaper at night however, cloth needs to be put on a cloth horse and the running machine at night may disturb the neighbours.”</p>

CHAPTER 10: USER PERCEPTION

<p>f) Switch the TV off if no one is watching</p>	<p>“TV in my house is only for video games.”          “I don’t have a TV.”          “Although we do have a timer on the TV so that if there is no moment for so long it switches off.”          “Rarely watch TV so it’s better for the system to do it automatically.”</p>	<p>“No need for that. I switch it off when I don’t watch.”          “I think most TV already has this function.”          “But again I would be annoyed if the system made an error and turned it off whilst I was watching something.”          “Could be a problem if trying to record programs.”          “My TV goes into idle mode when we are watching it! So the technology would have to be trustworthy and accurate for me to use this function.”          “Sometimes good to have background music/noise.”          “Would need a delay so that it stays on while you fill the kettle etc.”</p>
<p>g) Switch the power socket off once the appliance isn't used anymore</p>	<p>“Only for devices that use power when not in use, e.g. chargers.”          “Not for kettle, but I do it for chargers.”          “Only do this when going on holiday.”          “Joking? Can this save energy?”          “Sometimes I do this, sometimes it’s not necessary.”          “But that doesn’t save energy, or does it? I thought it is a quite English thing that power socket HAVE a switch. Never seen that before I came here.”</p>	<p>“I don’t mind this as if something is turned off then I have taken the decision to turn it off.”          “This would be useful as it’s very easy to forget to do.”          “Anyway, it might protect me from electric shock.”          “The only ones I leave on have clocks, timers, etc. that I don't want reset.”          “If it would turn back on automatically when I needed to use it.”          “As long as the system to do this consumes less power than the system it's switching off!”</p>

TABLE 10-3: COMMENTS RELATED TO OCCUPANT OR AUTOMATION CONTROL MEASURES

The statements, given in question 10, were rated by the participants as shown in figure 10-4. Additionally, selected comments detailing their views were listed in table 10-4.

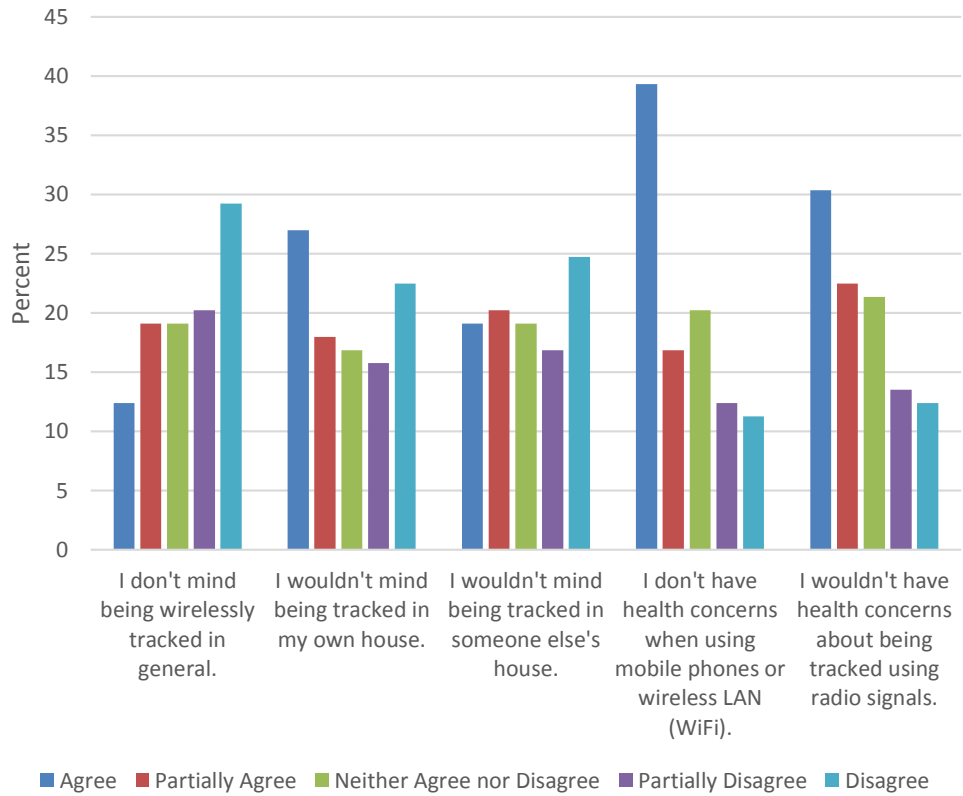

FIGURE 10-4: ACCEPTANCE LEVELS OF TRACKING AND DFL HEALTH CONCERNS

Statement	Comments
I don't mind being wirelessly tracked in general.	<p>“Don't like the concept of being tracked or monitored.”</p> <p>“I feel this may cause privacy issues.”</p> <p>“Only if it was for the saving system of my home.”</p> <p>“Although I see the benefit, security issue occur.”</p> <p>“Invasion of privacy but if only tracked to know when I have left the house, this is ok.”</p> <p>“My location and that of my family members should be private so this would only work if the info was anonymised.”</p> <p>“I systematically disrupt all attempts at persistent tracking of me, on ethical grounds. Nobody has the right to know where I am automatically except me.”</p>
I wouldn't mind being tracked in my own house.	<p>“As long as it is by a secure system that only the householders have access to.”</p>

	<p>“Prolonged staying with too much e-waves in the room might cause chronic health problem.”</p> <p>“I wouldn’t like the information to be available for anyone else, e.g. for the company who produces the tracking device. They could see for example if there are 1 or 2 people in the bedroom... weird.”</p> <p>“If there was no data stored, or if any data that was stored was stored on a box that I, and no other, had control over. That means no AppleTV or anything where anyone external to me has administrative access.”</p> <p>“Depends on how secure this tracking is, if someone could park outside the property and hacks into the wireless system and this then able to track those inside the house then I would mind very much!”</p>
<p>I wouldn't mind being tracked in someone else's house.</p>	<p>“I think it would make me feel uncomfortable.”</p> <p>“If there was no data stored.”</p> <p>“As long as the data is only internally used.”</p> <p>“As long as it was a friend who I trusted or the tracking information was anonymised.”</p> <p>“If I was staying there and it needed that system, then I wouldn't mind being tracked.”</p>
<p>I don't have health concerns when using mobile phones or wireless LAN (WiFi).</p>	<p>“The long term effects of these devices are unknown.”</p> <p>“Sometime I think about it... but what can I do? There are signals everywhere!”</p> <p>“Even if I am irradiating my brain with wireless signals, I'm sure other factors in my life will kill me first.”</p>
<p>I wouldn't have health concerns about being tracked using radio signals.</p>	<p>“Provided it was tested and proved safe.”</p> <p>“Within reason! What does "typical mobile phone signal" mean in the above? There's a lot of variation at different call stages of a mobile phone and at different distances from the cell tower.”</p>

TABLE 10-4: COMMENTS RELATED TO TRACKING ACCEPTANCE LEVELS AND DFL HEALTH CONCERNS

The question: “If you lived in a house, where you were being tracked in order to save energy; which type of tracking would you prefer?” was answered by 16.9 percent of participants with “tag-based” and by 83.1 percent with “tag-less”. A breakdown of the

multiple answer options chosen with regards to who the participants would like the data to be visible to, was presented in table 10-5.

Who would you like the data to be visible to?	Number of participants, who chose...		
	...only this option	...this and previous options	...this option in total
Nobody	20	20	26
Yourself	14	39	62
Other people living in the house	4	60	41
Maintenance Company	0	61	11
Energy Company	0	62	13
Research Institutes	0	81	25
Government	0	85	7
Third Parties	0	89	4
Total number of votes	38	89	189

TABLE 10-5: INDOOR TRACKING DATA VISIBILITY PREFERENCES

The results of both these security related questions were combined in figure 10-5.

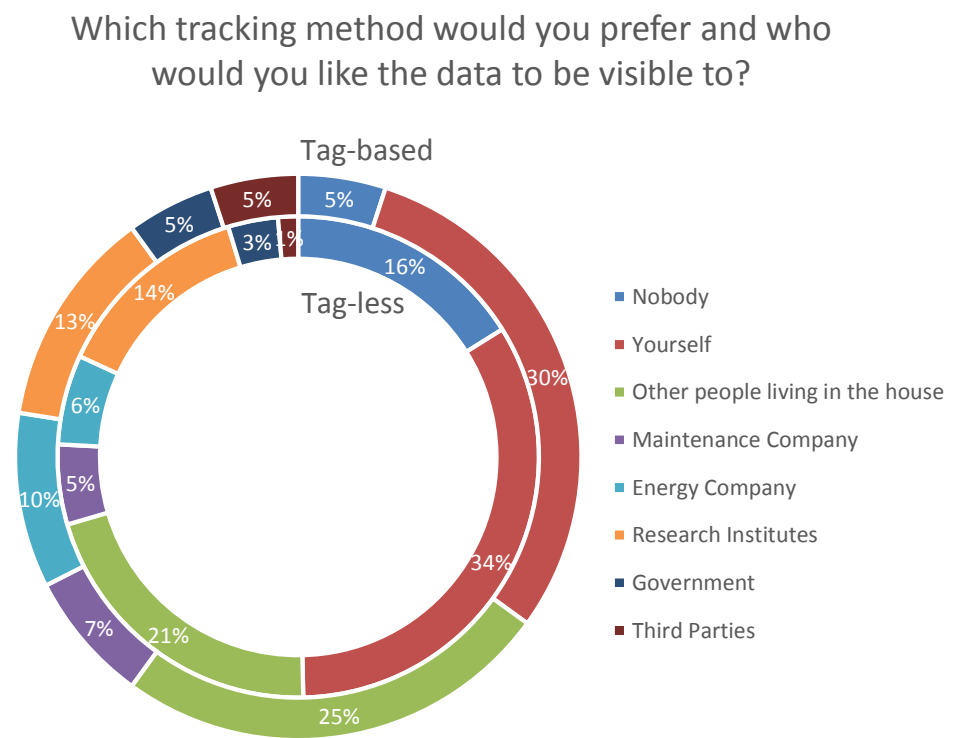

FIGURE 10-5: DATA VISIBILITY AND INDOOR TRACKING METHOD PREFERENCES

Finally, 48.3 percent of participants would consider purchasing an energy saving system based on DfL, if the payback period would be between one and two years. 39.3, 11.2 and 1.1 percent expected a payback period of three to five, five to ten and more than 20 years, respectively. Those values were highlighted and related to participants’ previous statements with regards to perceived energy prices by figure 10-6.

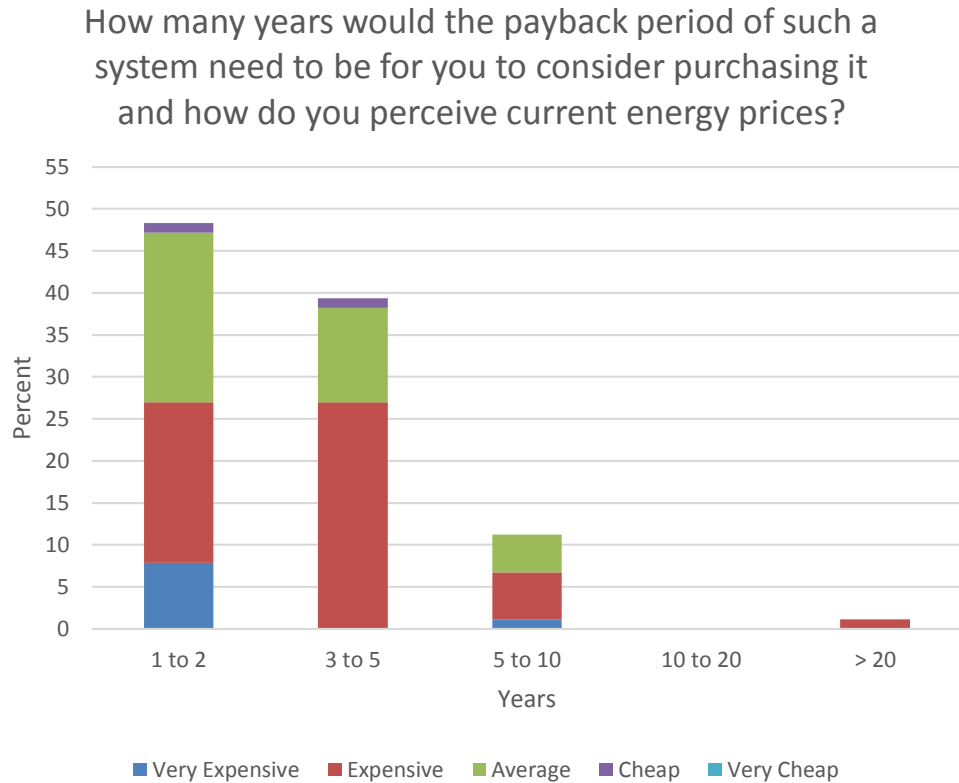

FIGURE 10-6: EXPECTED PAYBACK PERIOD OF ENERGY SAVING SYSTEM WITH DFL IN RELATION TO PERCEIVED ENERGY PRICES

### 10.4 DISCUSSION

The sample of participants represented both genders and a wide variety of the UK’s housing stock. However, as the questionnaire study was mainly set in a University environment, students with their associated age groups and living arrangements were overrepresented. Hence, a more extensive study would be required to accurately represent the UK’s demographics.

Figure 10-1 seemed to indicate a relation between the perceived energy price and the energy saving measures taken. The majority of participants, who felt energy prices to be “very expensive”, reported

to take energy saving measures "very often". Similarly, the majority of those who felt current energy prices to be "expensive", reported to take measures "relatively often". This would suggest that participants' predominant motivation was the financial benefit of saving energy. The responses given to the question "what encourages you foremost to save energy?" supported this suggestion. 35 participants chose the "reduce energy costs" option, i.e. two and a half times more than those who chose "protect the environment". The remaining participants were either motivated by both options equally or by their internal morals in relation to wastage. Retrospectively, the question should have been formulated as an open question rather than a multiple choice one, which might have prompted more accurate answers and potentially identified more types of motivations.

With regards to whether participants would let an automated system handle potential energy savings in their house, the majority were undecided. Their main concern, as suggested by table 10-1, was regarding the balance of control between the user and the automation system, and whether it was customisable. Some participants mentioned proven reliability and transparency as a vital condition for potential adoption, whilst others questioned the system's initial cost and its effectiveness in making financial savings. However, 40.4 percent of participants answered the question with "yes". The comments given by some of them in table 10-1 seemed to indicate that their own and other people's forgetfulness in making energy savings, were the predominant reason. Also, one participant highlighted that automated control systems could handle situations of "mutual assumption that another person in the house has turned the lights off". The remaining 9 percent of participants, who would not want an automated system handle potential energy savings in their house, mainly seemed to have no trust in automated systems. As indicated by table 10-1, they also feared a loss of control, a lack of flexibility and extra maintenance costs.

The participants' responses to the question: "Do you generally trust automated systems to make the right decisions?" had a similar distribution to the previous question, with 52.8, 30.3 and 16.9 percent answering "depends", "yes" and "no", respectively. As shown by figure 10-2, only one participant provided opposite replies

to both questions. This suggests that the responses to both questions were dependant, which implies that participants mostly referred to the notion of trust, when they assessed whether they would let an automated system handle potential energy savings in their house. However, as highlighted by table 10-2, concerns related to other notions, such as control, accuracy, reliability and transparency, also influenced their decision whether to trust an automated system in making the right decisions.

In fact, some comments to both discussed questions, as shown in tables 10-1 and 10-2, seemed to indicate that the concerned participants did not actually answer the question asked, but rather a substituted one. Kahnemann [61] suggested that people, who were asked a question which was too difficult for them to answer, often due to a lack of sufficient information, unknowingly substituted it with an easier question and answered that one instead. This did not necessarily bias the data, but rather provided a deeper insight into what participants associated with each of the questions; and although the majority was undecided, as figure 10-2 highlighted, the overall tendency of participants was towards allowing and trusting automated systems with potential energy savings in their houses.

The responses given to individual automation control measures, as represented in figure 10-3, further supported the suggestion of general acceptance of automated systems, as each of the seven measures received between 59.6 and 75.3 percent of approval. Additionally, participants provided valuable information, as shown in table 10-3, which could be employed during the design and implementation of the questioned automation control methods. Besides reiterating previously mentioned notions, such as control and reliability, some participants pointed out that certain appliances might have several applications. For example, televisions might be used to provide "background music/noise" rather than visual entertainment, or the light of one room might be required to maintain an acceptable light level in another room. Some comments also highlighted that the operation of appliances could be impacted by its wider context. For example, one participant stated that depending on the circumstance, they liked their bathroom to be hot or cold whilst having a shower. Others mentioned that white goods emit noise, require unloading and that their operation "need to fit



with days plans”, which could inhibit its start being delayed to night times. In fact, the case study described in chapter 11 investigated the time shifting of white goods in further detail. Other comments in table 10-3 with regards to automation control measures explicitly or implicitly highlighted the need for an occupant tracking technology. For example one participant stated that power sockets, which had been switched off, would need to be switched back on once the use of the associated appliance was required again. Another participant pointed out that televisions could “stay on while you fill the kettle”.

The occupant control measures on the other hand, received less consistent responses than the automation control measures. This was probably partially related to the fact that participants were able to assess their current state for the former and a hypothetical situation for the latter. The questions, which asked whether participants would switch lights, televisions and the heating of vacant houses off, were answered by more than 84 percent with “yes”, as highlighted by figure 10-3. The bathroom ventilation and heating of unoccupied room related questions were also predominately answered with “yes”, however participants pointed out, as shown in table 10-3, that lack of control, discomfort and the creation of damp were some of the reasons for which they could not take those saving measures. The energy saving measure of switching the power socket off after the associated appliance was not in use anymore only received 40.4 percent of “yes” answers, whilst 33.7 percent chose “occasionally” and 25.8 percent “no”. Some participants commented that they only take this action for certain appliances or “when going on holiday”, whilst others did not know that this could save energy. The question whether participants delayed the start of white goods to time periods of cheaper energy prices was the only one which received predominately negative answers, as shown by figure 10-3. The main reason, as five participants stated, could have been that they were on a single rate energy tariff. Some participants also commented that a “washing machine is too noisy to have on at night”. Chapter 11, as previously mentioned, discussed this particular energy saving measure in further detail and also in the context of smart energy tariffs. Conclusively, the participants were predominately willing to take energy saving measures themselves, which supports the concept of occupant control outlined in section 3.2. However, it is noteworthy

that the interpretation of the discussed data should be undertaken with consideration to the fact that participants' self-assessments might be inaccurate. The Energy Saving Trust [37] pointed out that 91 percent of people stated that they regularly switched off lights when leaving the room, but that only two thirds actually did so.

With regards to DfL, the results shown in figure 10-4 suggested that although the majority of participants would generally mind being wirelessly tracked, they would agree to it in their own house for energy saving purposes. However, an ambiguous situation such as personal wireless tracking in someone else's house let the general opinion tilt towards not wanting it, with 41.6 percent "disagreeing" or "partially disagreeing" over 39.3 percent "agreeing" or "partially agreeing". The main reasons given in the optional comment sections, as highlighted in table 10-4, were concerns with privacy and security of data access. One participant also highlighted that tracking someone without their consent is unethical. Another participant suggested that "prolonged staying with too much e-waves in the room might cause chronic health problem".

However, the majority with 56.2 percent chose to "agree" or "partially agree" that they had no health concerns when using mobile phones or Wi-Fi, as shown by figure 10-4. Similarly, 52.8 percent of participants seemed to have no health concerns about being tracked using radio signals. In contrast, some participants suggested that "the long term effects of these devices (were) unknown" and that the omnipresence of electromagnetic signals inhibited one's ability to choose their presence, as highlighted by table 10-4.

Furthermore, in the context of saving domestic energy a significant majority of 83.1 percent preferred a tag-less tracking method over a tag-based one. This supports the assumption made in chapter 4 that tag-based tracking systems are not applicable to the domestic environment and that DfL is an appropriate technology for the integration of COAC.

However, data security was a significant concern of the participants. To the multiple answer question: "Who would you like the data to be visible to?" 38 out of 89 participants, i.e. 42.7 percent, chose to only tick one option, which indicates that they felt very strongly about it. As shown by table 10-5, their choices were either

“nobody”, “yourself” or “other people living in the house”. Also, 60 participants, i.e. more than two thirds, only chose either of these three options. The only other choice that received considerable support was “research institutes”, which was probably overrepresented, as the questionnaire was mainly set in a University environment. Furthermore, figure 10-5 suggested that tag-based and tag-less voters had relatively similar interests in keeping the data only to themselves or other people living in the house, despite the former having the option to remove the tag and thus stopping the tracking process. However, as this option is not available to DfL users, the handling and storage of gathered data should be at the highest possible level.

The last question, which asked: “How many years would the payback period of (an energy saving automation system with DfL) need to be for you to consider purchasing it?” was answered by all but one participant with a time period of less than ten years. However, one participant pointed out in an unrelated comment section that they would not buy this system, but that they ticked the one to two year option as they had to make a choice. With other participants potentially in that same situation, the results might have been biased. Also, the person, who chose the more than twenty year option might have misinterpreted the question, as previous responses showed that this participant was moderately convinced by automation in general and very opposed to occupant tracking. Retrospectively, the question should have been designed in a manner which provided the participants with an option to display a disinterest in buying such a system.

On the other hand, figure 10-6 indicated that participants might have made their payback period choices based on their perception of energy prices. Participants who thought current energy prices to be “very expensive” predominately expected to get their investment back quicker, whilst the majority of those who believed energy prices to be “expensive” expected a payback period of three to five years. Although this relation was not apparent for all participants, it could imply that the findings were representative of participants’ financial interests in the discussed system.

## 10.5 CHAPTER CONCLUSION

The questionnaire study, which was based on a non-representative sample, suggested that an integrated DfL and COAC system could be accepted by the general public and highlighted areas which would require particular attention during implementation. Although wireless tracking was generally opposed, DfL was permitted in self-occupied houses under conditions of strict privacy and security settings. In contrast, the health concern of DfL, which was also outlined in chapter 5, was shared by a minority.

The general perception of domestic energy saving automation control systems was tilting in favour of its adoption, with valuable information gathered on acceptance criteria, such as control, reliability, transparency and performance.

The study also found that occupant control measures were taken predominately with the incentive of financial benefits. However, energy saving control measures were less well known or difficult to execute for occupants, particularly due to wider context factors, including undifferentiating energy tariffs.

With the concept of automation control approved, comparative case studies were conducted in three occupied dwellings to investigate the impacts of applied COAC, as described in chapter 11.

# **11 COMBINED OCCUPANT AND AUTOMATION CONTROL APPLICATION**

## **11.1 INTRODUCTION**

The concept of COAC, which was outlined in chapter 3, was shown by the previous questionnaire study, described in chapter 10, as potentially acceptable to the wider public. Furthermore, it was indicated that the control, reliability, transparency and performance of automation control systems would significantly influence its adoption. Also, the questionnaire study found that although participants were willing to take a range of occupant control measures, the majority was unwilling to shift the operation of white goods, such as washing machines or dishwashers, to periods of cheaper energy prices. A series of comparative case studies was undertaken to investigate these findings further and to examine the impacts of an applied COAC system on occupants. Particularly, factors which might affect the adoption and implementation of COAC, such as incentives and feedback methods, were analysed. The study was funded by E.ON AG as part of the SWITCH project [12], which unfortunately did not provide the opportunity to apply DfL to the COAC system. However, it allowed for the evaluation of whether further human and system integration was necessary.

## **11.2 METHODOLOGY**

Chapter 3 listed a variety of energy saving measures which could be included in a COAC system. It also pointed out in section 3.4.1 that some measures, particularly variable pricing schemes, were inherent to both, occupant control and automation control. Furthermore, chapter 2 highlighted that time dependent pricing schemes could make savings on the energy supply side as well as the demand side. Hence, this energy saving method was chosen as a platform for the COAC system developed during this study.

In accordance with the chosen time dependent pricing scheme, white goods were selected for automation, as they lend themselves to time shifted operation. In addition, three different user interfaces, which included occupant control feedback elements mentioned in section 3.2.1, were tested.

The COAC system was applied to three households. Two case studies were conducted in each of them, resulting in six case studies in total. The COAC system as well as interviews were used to collect data on the occupants' interactions and opinions.

Each part of this methodology was discussed in further detail in the following sections.

### 11.2.1 HOUSEHOLDS AND OCCUPANTS

Three houses with long term tenants, which were part of the University of Nottingham's "Creative Energy Homes" project [141], called BASF, Tarmac 10 and Tarmac 12, were chosen for this study.

The BASF house was occupied by one male and two female students of the ages 28, 30 and 38, respectively. It was equipped with a washing machine and a dishwasher. The house also had other unrelated monitoring and controlling equipment, which meant that the tenants had some previous experience with occupant and automation control methods.

The Tarmac 10 house was occupied by a married couple, consisting of a 23 year old female professional and 30 year old male student, and was equipped with a washer-dryer.

The Tarmac 12 house was occupied by a family, consisting of a 36 year old female professional, a 37 year old male professional and a 5 year old boy. Their house also had a washer-dryer.

The differences in occupants and circumstances supported the prospects of receiving a wider spectrum of feedback and information.

### 11.2.2 TIME DEPENDENT PRICING SCHEME

The COAC system, as previously mentioned, was built around a time dependent pricing scheme, which was used to integrate and provide occupant control and automation control measures. In other words, the varying prices were intended to incentivise occupants to save

energy, as outlined in section 3.2.2, whilst presenting a platform for automated DSM, as mentioned in 3.3.1.

With the study focusing on the time shifting of white goods, the pricing scheme was developed primarily to aim at the energy saving potential on the supply side, which was caused by the inability to control electricity demand, as demonstrated in section 2.4.1. Hence, a simplified RTP pricing strategy, as shown in figure 3-2, was designed to smooth electricity demand.

Due to unavailable live data, National Grid's [26] energy demand and Exelon's [27] wholesale prices from 2011 were used as the basis for this realistic time dependent pricing scheme.

The historical cost of each day's energy consumption was calculated based on system sell or system buy prices according to whether there was a surplus or shortage of electricity for a given half hourly period.

Also, the demand data was classified into low, average and high demand periods. To eliminate the seasonal variations, as shown in figure 2-9, the daily average was used as a reference. Arbitrarily a  $\pm 10$  percent threshold was chosen, which permitted occupants to take advantage of average demand periods during the day.

With reference to the historical energy cost and the combined energy consumed in each of the three periods per day, new prices were calculated for each half hourly low, average and high demand periods.

An example of a day's classified demand in relation to its newly designed prices was shown in figure 11-1.

However, during the course of this study it was decided to represent the different prices in colours rather than values, as the occupants would not have been able to benefit from those price differences. Hence, the low demand periods with the cheaper prices were presented in green, the average periods in yellow and the high periods in red.

Also, the developed time dependent prices were aligned with the weekdays of the study periods, as figure 2-10 pointed out that energy demand varies throughout the week.

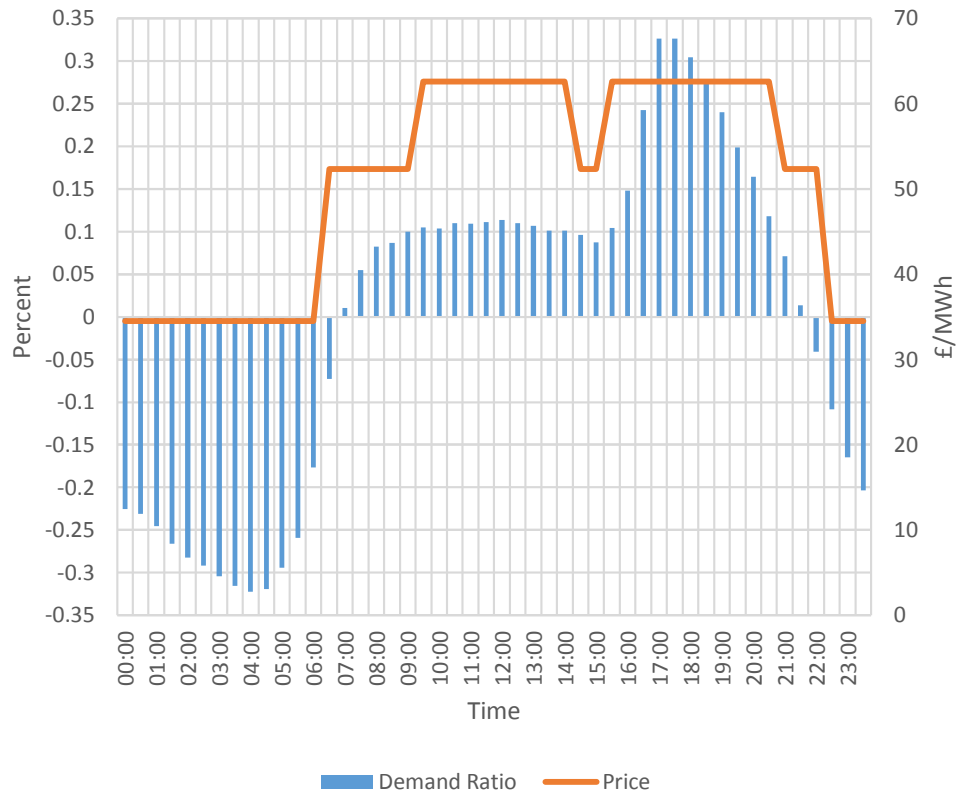

FIGURE 11-1: A DAY'S PRICING SCHEME DEDUCED FROM ITS DEMAND RATIO [26,27]

### 11.2.3 APPLIANCE AUTOMATION

As part of the COAC system, white goods were selected for automation for several reasons. They are frequently used appliances, with a considerable impact on energy consumption, which do not require the occupants' attention or supervision during operation.

In order to interface each house's white goods to the developed pricing scheme, which was outlined in section 11.2.2, they were connect to wireless plug sockets, which in turn were connected to a controller. The controller, which was programmed by another researcher, switched the sockets on or off dependent on the given simulated price period and the price the occupant was willing to operate the appliance on. However, for the appliance to start, the occupants had to initiate a program first. As this effectively meant that the appliances experienced a power cut, it was verified beforehand that each house's white goods would continue an interrupted program.



Websites connected to the controller, provided the occupants with the ability to choose the price periods they wanted to use for each of their appliances. In addition to implementing the websites, the other researcher developed four tariffs, the "green (£)", "orange (££)", "yellow (£££)" and "red (££££)" tariff. The green tariff only let the appliances run during green price periods, the orange during green and yellow periods, and the yellow only during yellow periods. The red tariff allowed the occupants to use the automated appliances at any time.

Furthermore, the other researcher included a "stochastic element" into the green price periods, which varied the start of a planned program within them. They also added an algorithm to only start a program, if it was able to finish within the given time slot. However, it is noteworthy that the algorithms treated different days as different entities, meaning that the price periods before midnight were not linked with those after midnight.

### 11.2.4 USER INTERFACE

In conjunction with the automated appliances, three different user interfaces were tested, which offered various degrees of control and feedback to the occupants.

The first interface, called "website only", provided the occupants with the household specific websites, mentioned in section 11.2.3. Thus, with a device of their choice, they could choose tariffs for each of their appliances and visualise the price periods.

The second interface, called "tablet", consisted of a tablet computer which was connected to the mentioned website and setup next to each of the appliances.

The third interface, called "override switch", was a two sided pushbutton switch, which was installed on the household's appliances. Pressing its "off" side was programmed by the other researcher to overrule any previously chosen tariff, thus starting an initiated appliance immediately, and resetting itself ten minutes after the appliance's program had finished. Pressing the "on" side was programmed by the other researcher to have no effect. In addition to the override switch, the occupants had access to the appliance specific websites with a device of their choice, as they did with the previous two interfaces.

In each of the three houses two types of interfaces were tested for several weeks. The durations of the resulting six case studies were represented in table 11-1 along with each household's tested appliances.

House	Appliance	Interface	Study Period
BASF	Washing machine & dishwasher	Website only	24/09/12 – 21/10/12
		Tablet	06/11/12 – 03/12/12
Tarmac 10	Washer-dryer	Tablet	16/10/12 – 12/11/12
		Override switch	15/11/12 – 30/11/12
Tarmac 12	Washer-dryer	Website only	25/10/12 – 15/11/12
		Override switch	16/11/12 – 03/12/12

TABLE 11-1: DETAILS OF THE CASE STUDIES

### 11.2.5 DATA COLLECTION

Data was collected by two means, the COAC system and interviews.

The COAC system recorded the occupants' interactions with regards to the interfaces and the appliances. Every tariff change and every push of the override switch were logged. Also, the energy consumption of each appliance was recorded, which allowed assumptions to be made on the time of initiation, the start, the length and the finish of a program.

Furthermore, semi-structured interviews were designed and conducted in conjunction with the other researcher. Each adult occupant was interviewed before the case studies, based on the questions shown in appendix C, and after each of the case studies, based on the questions shown in appendix D. The aim was to assess the impact the COAC system had on the occupants, including any potential behavioural changes and preferences with regards to incentives, interfaces and the COAC system in general.

## 11.3 RESULTS

The houses' occupancy during the case studies, which was determined from the interviews, as well as the pre-study statuses were outlined in section 11.3.1. The data collected via the COAC system and the post-case study interviews were presented in sections 11.3.2 and 11.3.3, respectively.

### 11.3.1 HOUSEHOLDS AND OCCUPANTS

During the BASF – tablet – case study, shown in table 11-1, one tenant was absent for the first fourteen days and another for the last fourteen. Due to this the latter tenant was post-interviewed two months after the case study had finished.

During the first sixteen days of the Tarmac 10 – tablet – case study, shown in table 11-1, the house was occupied by only one of the tenants and three guests. After a short vacant period both tenants returned with a new born baby on 6<sup>th</sup> November. As the initially absent tenant was not interviewed before the tablet – case study, no post-case study interview was conducted. Instead, they were asked the pre-case study interview questions before the override switch – case study, shown in table 11-1, during which all three tenants were present.

In the middle of the Tarmac 12 – website only – case study, one tenant left for a short period of time and returned with a new born baby. All four tenants were present for the override switch – case study, shown in table 11-1.

The information collected during the pre-case study interviews was presented in sections 11.3.1.1, 11.3.1.2 and 11.3.1.3 for the BASF, Tarmac 10 and Tarmac 12 house, respectively.

#### 11.3.1.1 BASF HOUSE

The pre-study interviews revealed that one tenant had moved in shortly before the start of the study and therefore had little experience with the appliances. In contrast, the two established tenants had a washing up routine that rarely involved the dishwasher, which was used approximately one or two evenings a month. However, for the purpose of this study they were asked to use it more regularly. One participant was unintentionally put in charge of it and predominately used two programs.

The washing machine on the other hand, was used once to twice a week per person. There was no set washing rota, it was only decided by availability. The time of use varied with each tenant. One mainly used it in the mornings and sometimes afternoons, one used it predominantly on weekends, and one usually in the evenings. Two tenants preferred to get a full load before starting the washing

machine and usually set it on the same programs. The other tenant used it when required and at varied settings.

With regards to whether cost or environment was being considered whilst using the appliances, one tenant replied "in my daily life I always try to reduce my consumption of material or electricity". Another tenant stated that they worried more about the energy bills than the environment, but suggested that "if you save energy a bit, you sort of look after the environment anyway". The third tenant mentioned not being particularly worried about cost or environment when using the washing machine. However, they pointed out that shared usage of constantly running appliances, like the fridge for example, was more economical and that the fear of electrical fires was a motivational factor for switching appliances off.

Furthermore, all of the tenants thought that they currently had insufficient feedback regarding price and environmental impact of energy to be able to make informed decisions. Additionally, they felt that researching provider specific information would be too time consuming and hence preferred to reduce their energy consumption instead.

The monitoring and controlling equipment mentioned in section 11.2.1, was able to reflect energy consumption, however, the tenants pointed out that they did not use this function due to the system's slow response rate.

With regards to the prospects of using the COAC system, all of the tenants felt that the website interface would be easy to use. However, one tenant believed that people who are not computer savvy might have problems, or would need extra time to get used to it. Also, after a demonstration of the COAC system, one tenant thought that "the reaction time (was) a little bit long". Furthermore, concerns were raised regarding the noise of the BASF house's rainwater pump, as that could potential affect whether they would use the COAC system for night time operation of the washing machine.

All of the tenants could see themselves using a similar load shifting system on a regular basis, mainly for the financial incentive. One tenant was also motivated by being part of a larger energy saving movement. The notion of being able to remotely control appliances was also appealing.

The tenants suggested that a developed version of a COAC system should present the financial savings in real time or overlay them with energy consumption data of previous month. One tenant also mentioned that the monitored data could be used to provide detailed energy saving advice.

#### 11.3.1.2 TARMAC 10 HOUSE

The couple, who lived in Tarmac 10, stated that they used the washer-dryer approximately three times a week, either in the evenings on weekdays, or at different times on weekends. Both tenants used the machine and had their favourite programs. However, one of the tenants considered themselves more responsible for it than the other. The tenants combined their wash loads, except for the baby clothes.

One of the tenants indicated that they sometimes thought about the cost and the environmental impact of using the washer-dryer, whilst the other said that neither impacted their usage. However, the latter pointed out that they changed energy providers in previous houses for financial reasons. Furthermore, they considered the energy price to be average.

Both tenants had never used energy display units.

With regards to the prospects of using the COAC system, one tenant judged the website interface as "quite clear, quite simple and user-friendly".

They could both see themselves using a similar system in the long term, with one being motivated by potentially reduced energy bills, whilst the other found the feedback on current energy prices and the ability to switch tariffs appealing.

#### 11.3.1.3 TARMAC 12 HOUSE

The pre-case study interviews revealed that the family, living in Tarmac 12, mainly used their washer-dryer in the evenings on weekdays and throughout the day on weekends. The choice of washing program was varied dependent on the material of the clothes and also on whether it was the child's clothes. They stated to use the machine between three and seven times a week. Also, one tenant was mainly in charge of operating the washer-dryer.

Both tenants mentioned that they were aware of the cost and the environmental impact of the appliance, but one highlighted: "If I have to clean, then I don't think about the cost, I just think about cleaning".

Additionally, the other tenant pointed out that they received their energy bill once a year, which they thought was inadequate in terms of feedback.

With regards to potential energy savings, one tenant indicated that they were not aware of any further saving potential. They also mentioned that there was no space in the house to dry their laundry, which effectively forced them to use the drying function of the machine.

Both tenants stated to never have used an energy display to monitor their consumption.

With regards to the prospects of using the COAC system, one tenant liked the extended control, whilst the other found the feedback appealing. However, there were also concerns that the system might break the washer-dryer.

They both really liked the overall concept and could "see a lot of people using it" long term, including themselves. One incentive was the ability to remote control initiated programs. Though one tenant pointed out that the financial savings would need to be large enough to compensate for the loss in flexibility, mentioning a figure of 10 percent, which was estimated to be equivalent to 80 pounds a year.

One tenant suggested that a developed version of a COAC system should present the user with the expected financial savings, if only the lowest energy price periods were used.

### 11.3.2 APPLIANCE AND TARIFF USAGE

The data collected by the COAC system was presented by house and by interface in figures 11-2 to 11-7, with an approximate precision of five minutes. Remarks to clarify relevant information, were put underneath each of those figures.

## CHAPTER 11: COAC APPLICATION

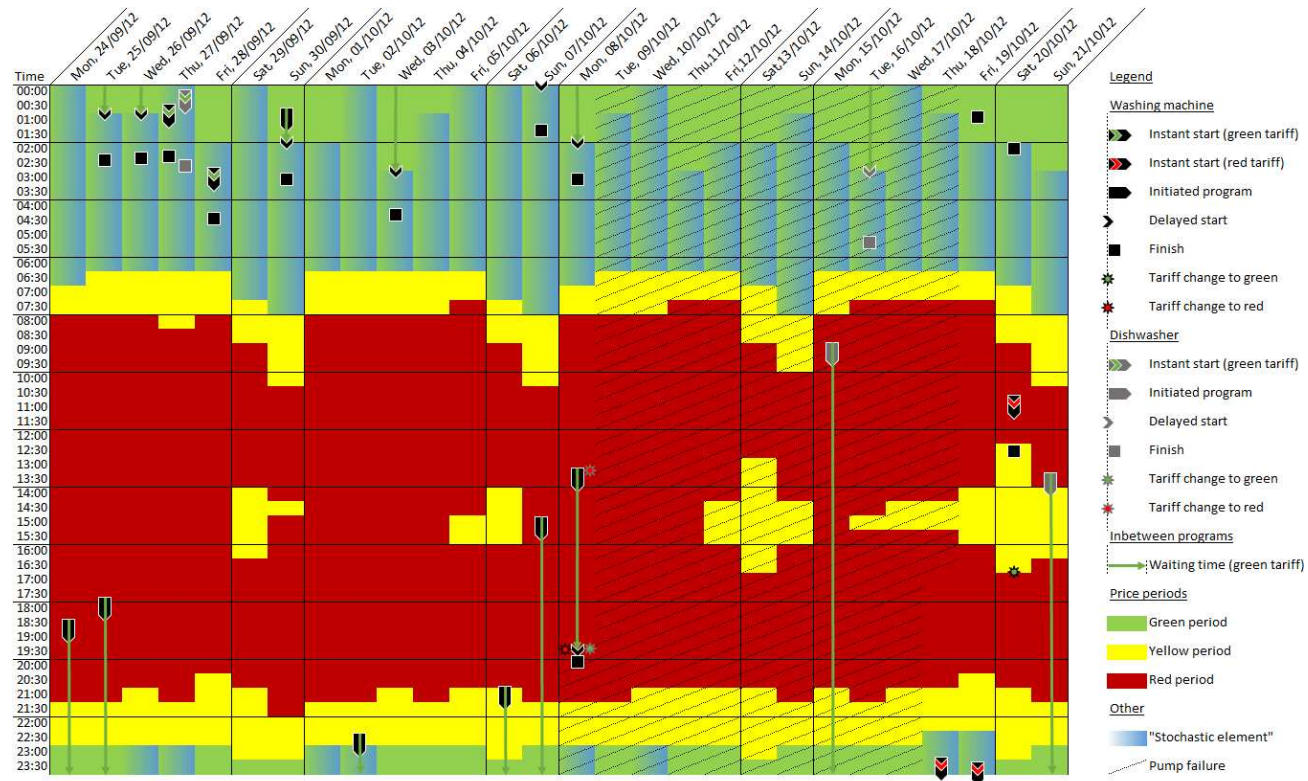

FIGURE 11-2: BASF – WEBSITE ONLY – CASE STUDY

**Remarks:** On 8<sup>th</sup> October BASF's, initially noisy, rainwater pump failed, which stopped the running program of the washing machine, and inhibited any subsequent operation until 18<sup>th</sup> October. However, the pump failure had no effect on the operation of the dishwasher.

## CHAPTER 11: COAC APPLICATION

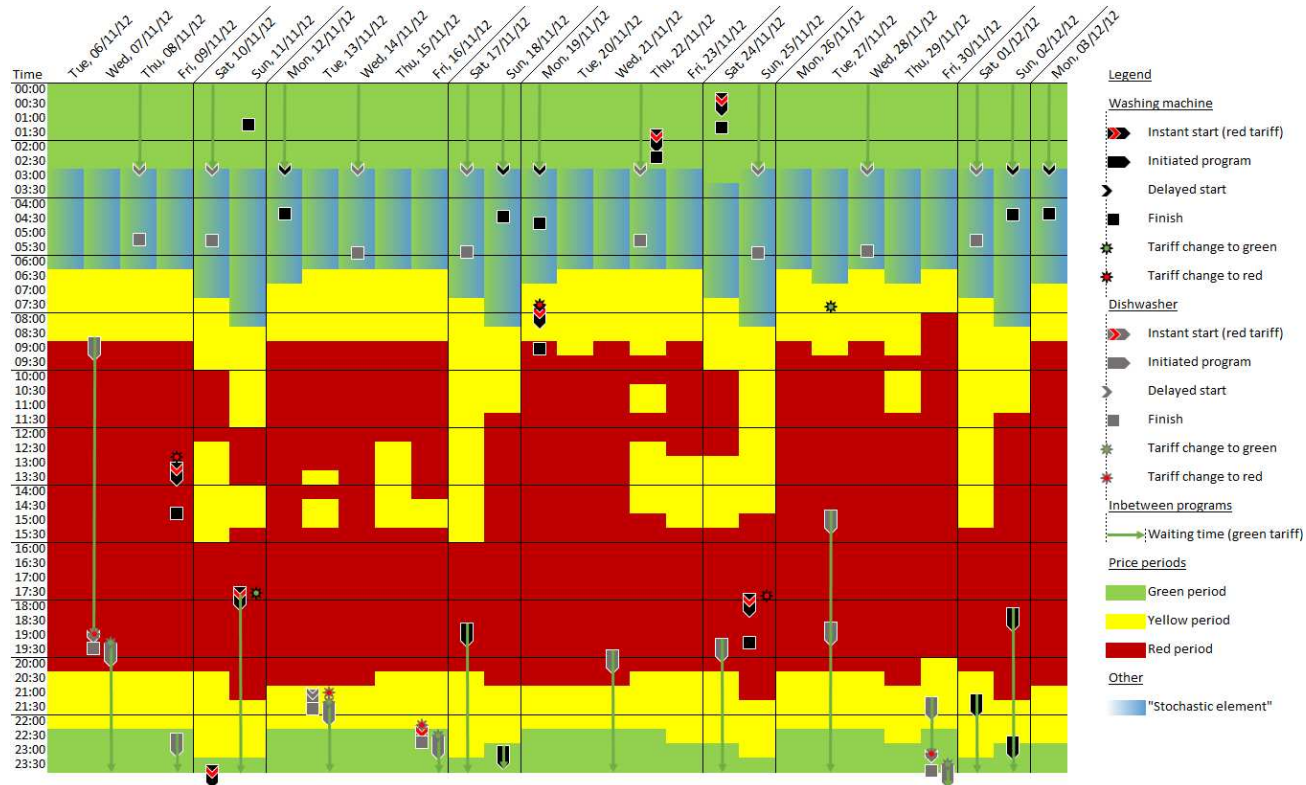

FIGURE 11-3: BASF – TABLET – CASE STUDY

**Remarks:** On 25<sup>th</sup> November after initiating a washing program, the tenant noticed that the tariff was set to red. Initially they changed it to green, but as the program had started and water had entered the washing machine, they decided to change the tariff back to red.



## CHAPTER 11: COAC APPLICATION

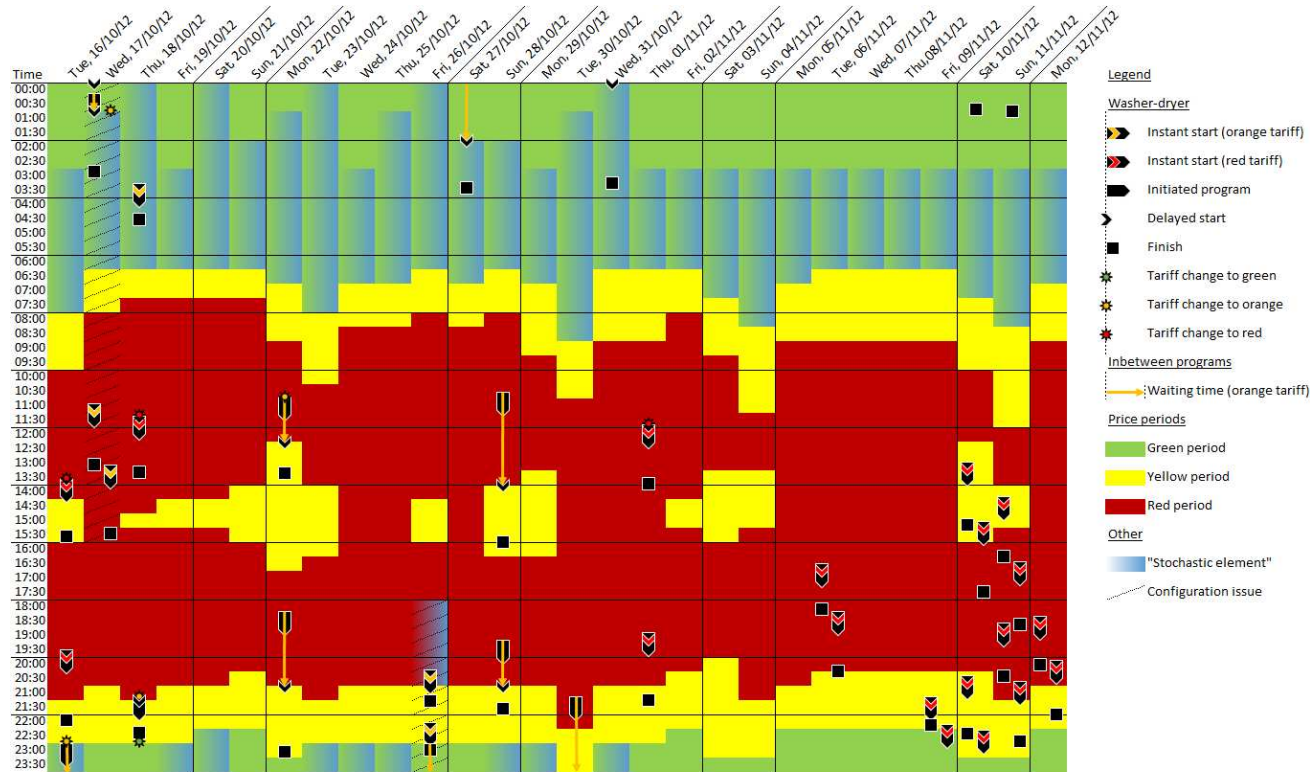

FIGURE 11-4: TARMAC 10 – TABLET – CASE STUDY

**Remarks:** The price period data from 16<sup>th</sup> to 31<sup>st</sup> October was two days behind the original weekdays from the 2011 data. Configuration issues on 17<sup>th</sup> and 26<sup>th</sup> October caused programs to behave in an unexpected manner by stopping prematurely or starting to run on the orange tariff during red periods. On 16<sup>th</sup> October after initiating a washing program on the red tariff, the tenant changed the tariff to orange, but as this stopped the washing process, they switched it back to red again. On 17<sup>th</sup> October the tenant changed the tariff to red, green and back to orange before the machine started again at the “stochastic” period at 1:00.

## CHAPTER 11: COAC APPLICATION

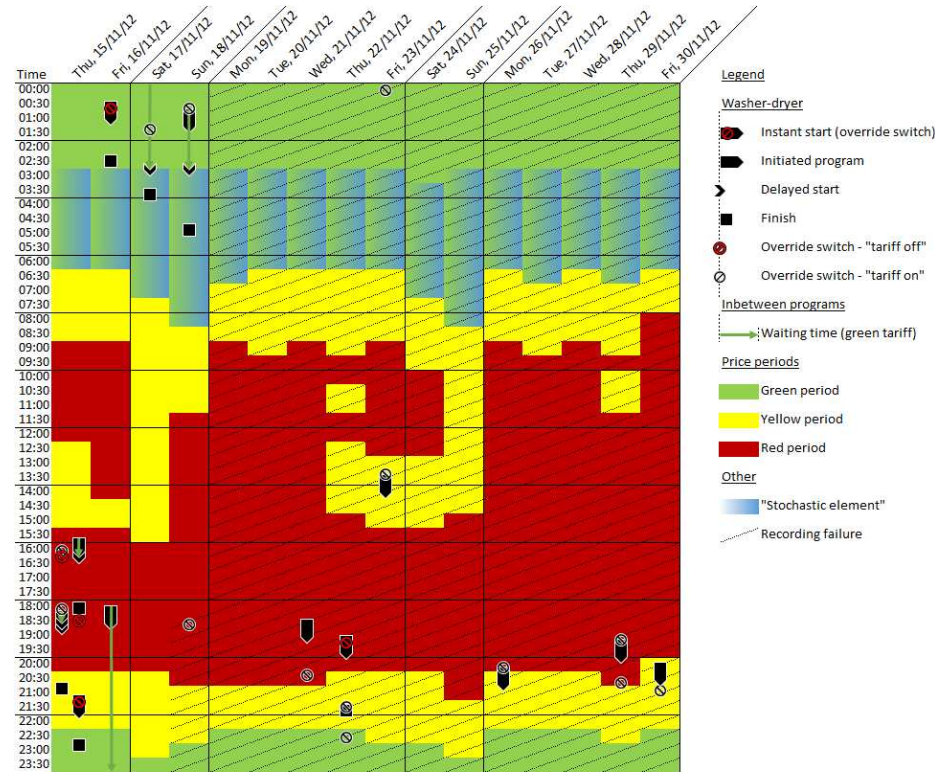

FIGURE 11-5: TARMAC 10 – OVERRIDE SWITCH – CASE STUDY

**Remarks:** All programs, except the one on 21<sup>st</sup> November, were initiated on the green tariff. Also, every time, except on 16<sup>th</sup> November, the “on” side of the override switch was pressed before the “off” side, with time differences of up to 20 minutes. A failure occurred on 18<sup>th</sup> November, which caused inconsistent recording of subsequent energy and tariff data. The sparsely available data was presented in figure 11-5, but no assumptions with regards to waiting times were made. Furthermore, it suggested that the previously ineffective “on” side of the override switch received some sort of function due to the failure.

## CHAPTER 11: COAC APPLICATION

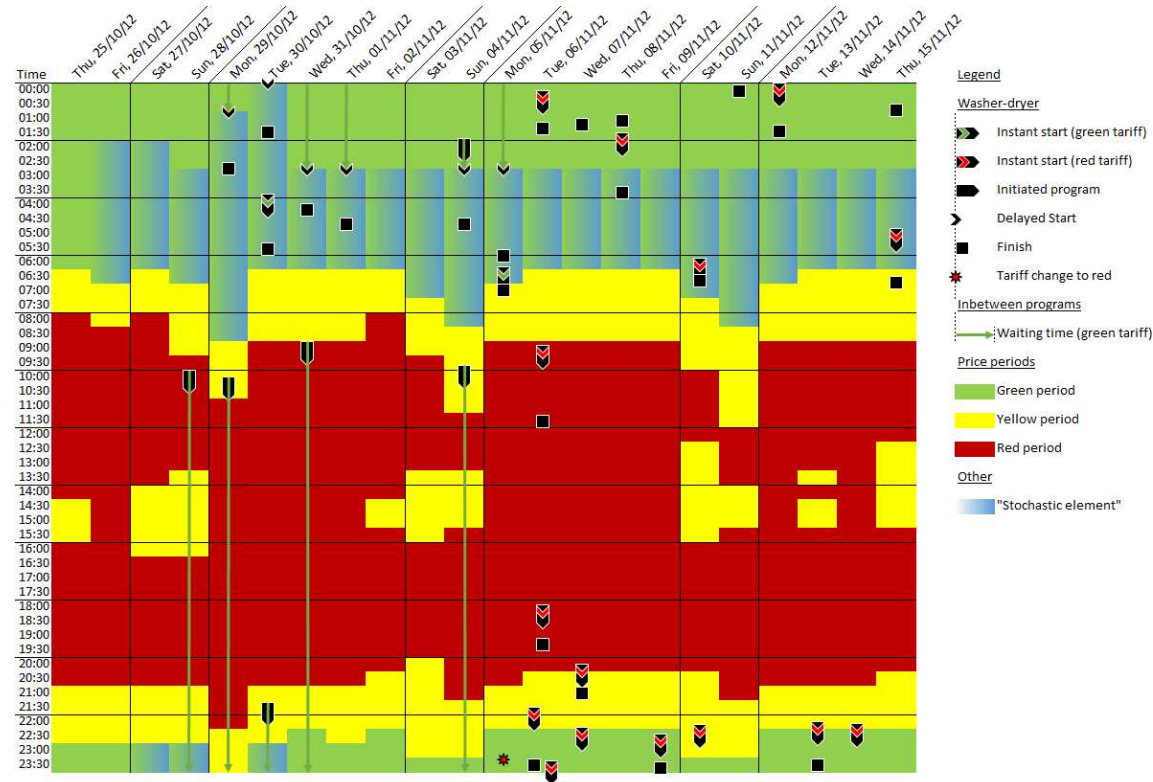

FIGURE 11-6: TARMAC 12 – WEBSITE ONLY – CASE STUDY

Remarks: The price period data from 25<sup>th</sup> to 31<sup>st</sup> October was one day behind the original weekdays from the 2011 data.

## CHAPTER 11: COAC APPLICATION

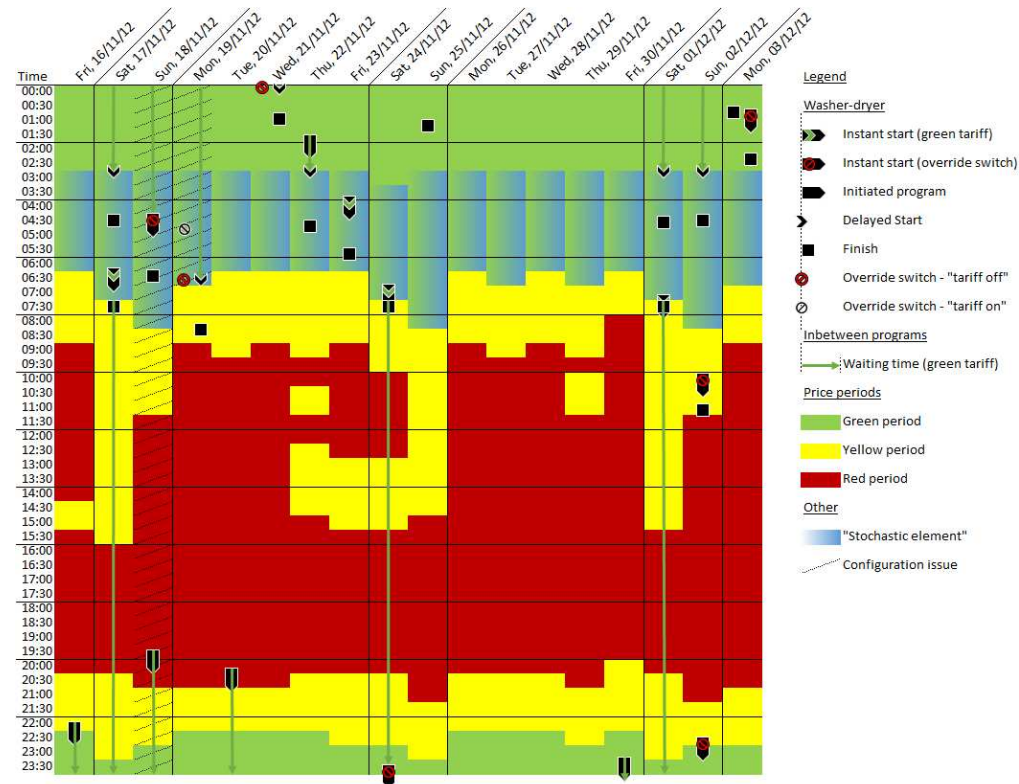

FIGURE 11-7: TARMAC 12 – OVERRIDE SWITCH – CASE STUDY

**Remarks:** The configuration issue on 18<sup>th</sup> and 19<sup>th</sup> November resulted in programs not starting automatically; hence, the tenants needed to press the override switch to start the programs manually. On 21<sup>st</sup> November, the “on” side of the switch was pressed seconds before the “off” side. On 3<sup>rd</sup> December the washing program was initiated before the override switch could reset itself, which resulted in the program starting immediately.

### 11.3.3 POST-CASE STUDY FEEDBACK

The information gathered from the post-case study interviews were outlined by house and by interface in sections 11.3.3.1 to 11.3.3.6.

#### 11.3.3.1 BASF – WEBSITE ONLY

The tenants' overall impressions of the COAC system after the website only – case study were positive. However, two tenants felt that they might need more time to adjust themselves to it. None of the tenants changed the washing programs they normally used. There was no change in the way the dishwasher was used either, as the occupants were still predominantly washing up by hand.

Some tenants especially liked the fact that the machines could be operated the same way as usual. However, one tenant thought that it was inconvenient that the washing machine only started after midnight, as that effectively meant that they could not take the load out until the next morning. Also, only one person could use the washing machine in a day, if they wanted to use the green tariff.

The added waiting period made sharing the machine a bit annoying for some. However, one tenant highlighted that previously there have been occasions where washed clothes were forgotten in the machine for up to one whole day and that "in this kind of situation you can actually adopt the habit to check the washing machine in the morning and you don't forget".

Another tenant added that this ultimately resulted in them taking turns with using the washing machine and doing regular washes to avoid "wasting a night".

Additionally, the tenants highlighted that if certain items needed washing for the next day, it was very difficult to dry them in time. One tenant was also worried that the wet clothes left in the washing machine for several hours might start to smell, especially in the summer. Usually they used to rinse and spin the load again if it stayed more than three hours in the washing machine.

As part of the wider context, the noisy rainwater pump, which was right below one tenant's room, was also mentioned as an issue. Furthermore, its failure, mentioned in figure 11-2, made them realise "how important this machine was, really".

All of the tenants said that they had moments when they wanted to change the tariff from green to red. Two tenants wanted to reduce the added waiting time, but resisted due to internal motivations and the system's reminder that the current tariff was cheaper. The third wanted to use available sunshine to dry their clothes, but did not know how to change the tariff.

All of the tenants were interested in the savings made and could see themselves using this kind of system on a long term basis. Their motivations for using the system did not change to prior to the study. However, one tenant highlighted that the savings needed to be substantial in order to continue using it. Several pounds per month were expected. The other two tenants were content with any kind of financial gain, as they saw the change in lifestyle as relatively "simple". However, when prompted, one tenant estimated financial savings of 10 percent and the other of 50 percent to be a sufficient incentive.

One tenant suggested that this type of system would be supportive during weekdays and inhibitive during weekends, due to the available times on green price periods for household chores.

Furthermore, it was suggested that future systems could take weather forecast data into account to allow for optimal drying conditions.

All tenants would theoretically allow the collected data to be available to third parties, such as private companies or public institutions.

#### 11.3.3.2 BASF – TABLET

The tenants stated that the dishwasher was used more frequently during the tablet – case study, but suggested that the responsibilities over it had not changed. The tenant, who was mainly in charge, pointed out that the pre-wash program, which was necessary to fully clean the dishes, could not be selected in conjunction with the main program. They also added that during the website only – case study they omitted this program, as they would have had to go to their room to change tariffs. However, with the tablet, they decided to use the red tariff for the pre-wash program and then the green tariff for the main cleaning program.

Another tenant suggested that the dishwasher was more compatible with the COAC system than a washing machine, as the cleaned load could be left inside for any period of time, whereas wet clothes left in the washing machine became wrinkled.

None of the tenants changed their washing machine program choices.

One tenant considered changing the tariff after coming back from a long journey, but resisted. Another tenant said that they noticed that tariff was on red after having started the washing machine. They switched the tariff back to green, but then decided to let it run on the red tariff, because they thought the water, which had entered the machine, might start to smell otherwise.

All tenants unanimously considered the tablet to be more “convenient” than the website only – option. The main reasons were the ability to change tariffs more easily as well as getting feedback on price periods and estimating any waiting time.

One tenant also highlighted that during the website only – case study, they were referring to another tenant to get information about the system, as they had difficulties accessing the website themselves. With the tablets on the other hand, they were better able to understand and use the system by themselves.

All three tenants’ willingness and motivations with regards to adopting a similar system on a long term basis had not changed. However, one tenant indicated that they needed a larger financial incentive, than they stated during the website only – case study. They also highlighted that they would only use the green tariff for the dishwasher and not the washing machine, as they would not want to have to wait. Additionally, they suggested, as did another tenant in section 11.3.3.1, that weekend time available to household chores could not be used effectively.

Another tenant suggested that future systems should show energy usage and savings in relation to the chosen program and tariff, either in real time or even before the program was started.

11.3.3.3 TARMAC 10 – TABLET

The tenant thought that the system was “quite handy” and suggested that the guests liked it, too. However, they seemed confused by the orange and yellow tariff choices.

Before the guests arrived, the red tariff was used by the tenant to clean sheets and other things. They then changed the tariff to orange, as they deemed that one to have “the perfect time for washing”.

The tenant highlighted that although a 60°C washing program with an approximate duration of two hours was used before the study, they now used a “30 or 40” degrees program with a duration of one and half hours, so that it would fit into the available price periods, together with the half hour drying program. The tenant also added that they did not notice any difference in quality of cleaning.

However, they pointed out that when they left the house, they would choose the 60°C program, as they would be unable to initiate the drying program in time.

The guests, who were using the washer-dryer too, were initially briefed by the tenant. They were thought to have used the orange tariff, as they were mainly out of the house during the day and did their laundry in the evenings. Also, the tenant needed to remind the guests about the system, after it had switched itself off during the afternoon on one occasion. The tenant said that the guests were happy to leave it on orange after that. However, they suggested that a household of five or six people might have difficulties to cope with this system.

The website was thought to be “very user-friendly”. The tenant also liked the ability to effectively overrule the system by choosing the red tariff, when something needed to be washed urgently. Furthermore, they believed that the guests mostly did not even notice the system.

The tenant could see themselves using a similar system over the long term, with the financial savings as main incentive. They thought that around 30 pounds a year would make it worth their while. Furthermore, they were enthusiastic about adapting other energy usages around the house to the time varying prices of the COAC system.



In relation to future versions of this system, the tenant suggested that appliances should be able to interact with the time dependent prices to flexibly adapt their internal programs to available periods.

Also, the tenant would be willing to let third party organisations use the collected data.

### 11.3.3.4 TARMAC 10 – OVERRIDE SWITCH

The tenant, who had returned during the previous case study, as mentioned in section 11.3.1, was now almost solely in charge of using the washer-dryer. However, the interview revealed that this tenant believed that the installed switch needed to be pressed in order to take advantage of the cheaper tariffs. They based this assumption on the fact that the machine did not turn on at least once after they had pressed the button. They also never consulted the website.

The other tenant seemed not aware of this situation and believed that the green tariff was mainly being used. Furthermore, they suggested that the other tenant expected the system to randomly switch the washer-dryer off, and that they therefore changed their usual program to a shorter one. Another reason for the shorter programs was the more frequent use due to the added laundry from the baby. However, there were concerns whether that might result in a less clean wash.

The tenant, who experienced both case studies, thought that the override switch was more convenient, as they only needed to set the tariff once and were able to use the button for the exceptional cases. In contrast, although they thought the tablet was too “sophisticated” and took extra space next to the appliance, they pointed out its advantage of showing the daily changes in price periods.

Furthermore, the tenant indicated that checking the price periods on the computer was an extra effort during this case study, and that therefore assumptions were made once the machine had been started, based on whether the COAC system allowed it to run or not.

This kind of system was seen as a possible long term option, especially as their desired price periods matched the time they usually used the machine on. As their lifestyle was not affected, no

specific amount of financial savings was required as incentive. However, five or “even three percent” of savings were deemed good.

The tenant also highlighted that this kind of system might not be convenient to a household, in which a person predominately stayed at home during the day.

With regards to improvements, one tenant suggested that an LED screen, which indicated the duration of the current price period, could be an alternative interface option to the tablet, and could be used in conjunction with the override switch.

#### 11.3.3.5 TARMAC 12 – WEBSITE ONLY

The post-case study interviews revealed that the tenants did not feel comfortable with the COAC system, as they thought that it was inconvenient.

One tenant pointed out that they were unable to plan ahead, as it was not possible for them to tell when the machine would come on. They pointed out that when they chose the green tariff, the washing program would start around one or two o’clock, and would finish around six o’clock, although other times were shown on the website interface.

Both tenants also stated that this reduced amount of time was not enough for them to do their washing, especially as they had no space to dry their clothes and therefore needed to separately run a drying program on the washer-dryer. This effectively meant that it took them two days to wash and then dry their clothes. Hence, it was pointed out that one of the tenants had to wake up in the night to put on the drying program.

As the lost time created a backlog of washing, they decided to change the tariff to the red one. However, one tenant highlighted that they wanted to “leave (the green tariff) on for at least a week to see exactly what happens”.

Also, both tenants mentioned that they expected a considerably greater amount of green price periods on the weekends. Additionally, one tenant seemed surprised that green price periods did not start earlier in the evenings.

On the other hand, one tenant liked that the system did not change the way the machine was operated and thought that the current difficulties with the COAC system could be related to the fact that they were not used to it.

The same tenant would consider adopting a similar system on a long term basis at the conditions that the price periods were different and that the cost savings would be around 50 percent.

The other tenant would not want a similar system, even if it was associated with substantial cost savings, as the lack of control was perceived as a substantial hindrance.

With regards to future COAC systems, the tenant suggested washing programs to be divided into smaller parts, so that they can be run throughout the day. Another suggestion was to let the system decide whether to let a program run or not depending on its accumulated cost and its temperature setting. The other tenant pointed out that they would like the ability to choose when the green periods were.

Both tenants did not mind sharing the potentially collected data with third parties.

#### 11.3.3.6 TARMAC 12 – OVERRIDE SWITCH

The override switch – case study was perceived as “much better” by both tenants compared to the previous website only – case study. However, at least one tenant seemed to believe that the override switch replaced the website interface, rather than being an add-on feature, as they mentioned that they were missing the ability to switch tariffs or see which one was currently being used. They also pointed out that generally not enough feedback was provided with this setup, with regards to when the machine would start operating after its initiation.

The other tenant found the system “not difficult to use”. To prevent a backlog of washing, they used the washer-dryer during the week on the set tariff, and on weekends, they used the override switch, because the child’s uniform needed to be washed and dried.

Also, the change in interface improved one of the tenant’s opinion of the COAC system, as they could “wash something quickly” by using

the override switch. They highlighted that they knew about the difference in cost, but that sometimes there was no way around it.

The other tenant was very hesitant about whether or not to use this kind of system long term. They liked the fact that programs could be postponed, but felt that more control was needed. They suggested that being able to choose the exact time when the machine would come on during green price periods would be a potential improvement.

The other tenant was more motivated to adopt this kind of system over the long term, than after the website only – case study, mentioned in section 11.3.3.5. However, they suggested that better feedback with regards to predicted financial savings was required and proposed to exclude Sundays from the time dependent pricing scheme.

### 11.4 DISCUSSION

The data from the interviews and the COAC system showed the complex relation between the occupants and the automation system in a realistic context.

A variety of factors, including incentives, control and feedback, influenced the acceptance level of the COAC system. The majority of participants was incentivised by financial savings, however, the amounts required to adopt a COAC system under its presented form, varied significantly. Also, the savings needed to outweigh the perceived loss in comfort, which could be caused by a lack of control and feedback, as highlighted in section 11.3.3.5. In contrast, improved control of the automation, as perceived by one of the tenants in section 11.3.3.6, directly improved the perception of the COAC system.

Furthermore, due to insufficient feedback, participants decided to make assumptions with regards to which tariff they were using or how the overall system was operating, as mentioned in section 11.3.3.4.

On the other hand, the levels of control and feedback were not restricted by the study. In fact, all participants had access throughout to the tariff control and price period feedback via the

internet. However, as the case studies demonstrated, the proximity between the operated appliances and the user interfaces, which provided the control and feedback, played a crucial role. Hence, the tablet and the override switch were distinctively preferred over the website only – solution. With regards to a preference between tablet and override switch, the occupant of tarmac 10, who was the only one to experience both, seemed to prefer a combination of both, as mentioned in section 11.3.3.4.

Also, the website interface was deemed by the majority as user friendly during the pre-case study interviews. However, one tenant mentioned that they did not know how to change tariffs in section 11.3.3.1, and another accidentally changed the dishwasher tariff instead of the washing machine tariff on 8<sup>th</sup> October in figure 11-2. Therefore, besides the proximity, the clarity of the user interface should be considered during COAC implementation.

Additionally, reliability of feedback, as pointed out in section 11.3.3.5, is required to allow users to plan ahead. Particularly, as it was shown that the wider context affected how the appliances were operated. Factors, such as weather, available drying space and urgency with which the clean clothes were required, all influenced how occupants operated their machines.

The appliances themselves, also impacted on the operation process of the COAC system. Although the majority of participants pointed out that they liked that the appliances could be used in the same way as before study, they did notice that the appliance's separate initiation of two subsequent programs could result in two nights being spent on one washing and drying cycle, as described in section 11.3.3.5. In this context, the BASF occupants developed a coping mechanism, which meant that they operated the dishwasher's pre-wash program on the red tariff, whilst operating the main washing program on the green tariff, as shown in figure 11-3. However, with washer-dryers having longer program times, the occupants of Tarmac 12 had to wake up during the night to cope with the limited available time on green price periods, as shown in figure 11-6.

This choice between saving money or losing time was shown to impact the internal structures of a household. The BASF tenants, who had no washing routine before the case studies, employed a

rota to maximise the usage of the lower price periods, as described in section 11.3.3.1. However, one tenant, who had three guests, suggested in section 11.3.3.3 that larger households might not be able to cope with this limited availability.

On the other hand, the mentioned constraint also yielded energy saving behaviours. One BASF tenant mentioned in section 11.3.3.1 that they developed the new habit of checking the washing machine in the mornings, which meant that wet clothes were not forgotten about and hence did not need to be re-washed due to smelling bad. Another participant purposely shortened their programs to the available time slots, as mentioned in section 11.3.3.3, which made them reduce the temperature of their washing programs.

However, the results also suggested that a time dependent pricing scheme, as the one implemented, might actually increase energy usage. As shown in figure 11-7, programs were interrupted when green price periods ended, which might have resulted in the tenant restarting the same program from the beginning on 24<sup>th</sup> November. However, even if they did not notice that the program was interrupted by the COAC system, insufficiently washed or dried clothes could be the result.

Furthermore, several participants pointed out that the time dependent energy prices were restrictive on weekends, when they had time for chores or needed to wash the kid's uniform for the next week. Hence, some suggested an improved coordination between appliances and pricing schemes, whilst others suggested pre-booked periods or exceptions for weekends.

All of the participants were willing to theoretically provide third parties with the data generated by COAC systems. However, the fact that they lived in experimental houses, as outlined in section 11.2.1, might have influenced their reactions and behaviours.

### 11.5 CHAPTER CONCLUSION

The study demonstrated the complex relations which affect COAC adoption, operation and implementation. Especially, the financial incentives, the control and the feedback provided by COAC systems were found to be with regards to user acceptance, which supported chapter 10's findings. It was established that the availability, clarity

and reliability of feedback influenced the occupants' interactions with the COAC system and hence the exploitation of energy saving potential. Similarly, it was shown that appliance features and the wider context the appliances were operated in could negatively impact their energy saving potential once automated. Furthermore, it was demonstrated that occupants can quickly develop behavioural changes in order to adapt to time dependent pricing schemes. However, it was also pointed out that limited availability of low energy price periods might strain household dynamics and could cause inefficient energy usage. Hence, further integration between occupants, appliances and time dependent energy price schemes is required, which could be provided by DfL, as suggested in chapter 3.

## **12 CONCLUSION**

### **12.1 INTRODUCTION**

The novel concept of COAC was developed in this thesis, which simultaneously outlined the requirement for an occupant detection technology. Hence, an occupant detection technology appropriate for COAC application needed to be identified, and its feasibility and acceptance, as well as that of the COAC system, required investigation. This chapter discussed the findings of the previous chapters in relation to this overall aim and identified potential future research directions.

### **12.2 DISCUSSION AND CONCLUSIONS**

The necessity and urgency for domestic energy savings was outlined. It was shown that in the light of global warming, rising populations and reductions in fossil fuel energy sources, energy demand has to be dramatically reduced, and that the domestic sector was the biggest consumer. Furthermore, it was highlighted that structural energy efficiency will not suffice and that therefore operational energy savings will need to be made.

The saving potential was identified to be on both, the energy provider and the energy consumer side. Furthermore, it was shown that the aggregated effect of occupancy was directly linked to the former. Also, studies, which quantified the latter, were reviewed and it was suggested that between 14 and 42 percent of electricity consumption could be saved.

Hence, a variety of energy savings methods were studied and classified. Occupant control, which mainly provides feedback and incentives, was shown to be unreliable in achieving consistent energy savings. Automation control, which makes savings directly using special equipment, was also shown to be ineffective due to their user interfaces and their inability to identify potential energy savings.



As a result, the concept of COAC was developed and the requirements for its implementation, which consisted of an unobtrusive occupant detection technology with the abilities to localise and track multiple people in a dwelling.

Therefore, the first objective, as mentioned in section 1.2, was to identify an occupant detection technology, which was applicable to dwellings and fulfils the requirements imposed by the COAC system.

Three technologies applicable to domestic environments were identified and experimentally compared, which found that the CO<sub>2</sub> and PIR based occupant detection technologies had significant disadvantages. CO<sub>2</sub> had a slow response time and was influenced by the operation of doors and windows; whilst PIR was prone to false outputs and limited in its visual field. Also, both of those technologies were proven unable to track occupants and therefore did not fulfil the requirements set out by the COAC concept.

However, the experiment indicated that the third occupant detection technology, DfL, might have those potentials. Additionally, its ability to use an automation control system's and hence a COAC system's existing wireless infrastructure, has substantial advantages, such as reduced hardware cost.

With DfL being an emerging technology, a literature review was conducted, which established its current research state and found that the integration of DfL and COAC had not been attempted. The review hence identified significant gaps in knowledge, particularly with regards to radio deployment and operation in the context of a shared infrastructure. Also, it was pointed out that previous research combined analysis methods with their DfL findings, which obscured its characteristics. Furthermore, with DfL requiring domestic application, potential health and security concerns were outlined, which were argued to influence DfL's adoption potential.

Based on this, the thesis adopted two separate approaches to investigating DfL, a technical and a practical approach.

For the technical approach, which aligned with the second objective mentioned in section 1.2 of assessing DfL's capabilities, a series of experiments was conducted using simple statistical tools. They confirmed previous research findings and extended the knowledge with regards to COAC integration. It was demonstrated that RSS, on

which DfL is based, reacts at various frequencies to human movement and presence. In addition, the relation between the radios' positions and the body's surface, was shown to impact RSS. However, the significant interference of indoor environments on DfL was also demonstrated, and it was shown that signal reflection and diffusion, rather than absorption, build the foundations for DfL. Hence, suggestions with regards to radio deployment were made and backed up by experiments. For example, it was shown that radios should be elevated. Also, increased number and density yielded improved results. However, for the temporal resolution, it was shown that DfL needs to compromise between data volume and energy efficiency. Furthermore, the requirements highlighted by the COAC concept, were confirmed and it was found that DfL was 100 percent accurate in localising a person. Additionally, it was demonstrated that several persons could be localised and that a person could be tracked within a radio network. However, it was shown that interpretation methods could affect DfL's accuracy.

For the practical approach, which aligned with the third objective mentioned in section 1.2 of investigating the public's perception of indoor localisation and energy saving occupant and automation control methods, a questionnaire study was conducted. It found that the majority of the participants had significant privacy and security concerns. However, the health concerns, which were outlined, were not confirmed. Also, the study found that whilst participants did not like to be tracked in general, they were predominately in favour of DfL in their own house, if it was for energy saving purposes. Furthermore, participants expressively preferred tag-less tracking options, over tag-based ones. With regards to COAC, the study highlighted that financial savings were the biggest incentive. Although the majority of participants was undecided about the adoption of automation control systems in general, they were inclined to predominately allow the automation of specific tasks. Occupant control on the other hand seemed widely in place, but showed significant differences in its implementation and willingness to adopt it. Some energy saving measures, were also simply not known. Additionally, the questionnaire study highlighted features a COAC system requires for adoption, such as sufficient control, reliability, transparency and performance.

To confirm these findings, the fourth objective mentioned in section 1.2 was to develop and test a COAC system, which was done in conjunction with another researcher and implemented in three occupied dwellings. By using semi-structured interviews, it was found that financial incentives were the main driver for potential COAC adoption. Also, the wider context in which the COAC, and in particular the time dependent pricing scheme, were set, significantly affected occupants' energy saving behaviours and their household dynamics. Additionally, by varying the control and feedback of the user interface, it was demonstrated that further integration between the occupants and the automation control system was required.

Conclusively, this thesis has developed the novel concept of integrating DfL and COAC, and has shown that it is technically and practically feasible, by simultaneously outlining guidelines with regards to its implementation from a system's and an occupant's point of view.

### 12.3 FUTURE RESEARCH DIRECTIONS

As the concept has been newly developed, many aspects of COAC – DfL integration require further investigation. Some have been outlined in previous chapters.

For example, the design of radios could be adapted to indoor networks, improving antennas' transmission patterns and using protocols, which are specialised in compromising between COAC and DfL operation as well as privacy and security protection.

Also, as it was shown that human presence can be detected outside the LOS, RSS interpretation methods need further development, particularly with the demonstrated interference of internal environments. Perhaps the layout of dwellings could be taken into account for this purpose.

Research on the emerging smart appliances and DSM techniques is also required in order to consider occupant and household dynamics.

Finally, the overall energy saving potential achievable with COAC – DfL systems should be evaluated experimentally.

## REFERENCES

- [1] International Energy Agency (IEA), *World Energy Outlook 2012*, Paris: IEA, 2012.
- [2] United Kingdom. Department of Energy & Climate Change (DECC), *Digest of United Kingdom Energy Statistics 2013*. London: DECC, 2013.
- [3] United Kingdom. DECC, "Energy consumption in the UK (ECUK)", 2013. [Online] Available: [https://www.gov.uk/government/uploads/system/uploads/attachment\\_data/file/238797/domestic.xls](https://www.gov.uk/government/uploads/system/uploads/attachment_data/file/238797/domestic.xls) [Accessed: 28 January 2014].
- [4] BRE Trust, *Energy efficiency in new and existing buildings: Comparative costs and CO<sub>2</sub> savings*. Bracknell: IHS BRE Press, 2010.
- [5] H. Hens, "Energy efficient retrofit of an end of the row house: Confronting predictions with long-term measurements" *Energy and Buildings*, vol. 42, pp. 1939-1947, 2010.
- [6] Energy Saving Trust, *The rise of the machines: A review of energy using products in the home from the 1970s to today*. London: Energy Saving Trust, 2006.
- [7] J. Palmer and I. Cooper, "United Kingdom housing energy fact file 2012", DECC, London, UK, Rep. URN12D/354, December 2012.
- [8] J. P. Zimmermann et al., "Household Electricity Survey: A study of domestic electrical product usage" Milton Keynes, UK, Rep. R66141, 2012.
- [9] J. P. Zimmermann, "End-use metering campaign in 400 households in Sweden, assessment of the potential electricity savings" Felines-sur-Rimandoule, France, Rep. 17-05-2743, 2009.
- [10] European Union. Commission of the European Communities, *Demand-side management: End-use metering campaign in 400 households of the European Community, assessment of*

- the potential electricity savings - Project EURECO*. Rep. 4.1031/Z/98-267, 2002.
- [11] European Union. Executive Agency for Competitiveness and Innovation, *Residential monitoring to decrease energy use and carbon emissions in Europe*. Coimbra, Portugal.
- [12] R. Shipman, M. Gillott and E. Naghiyev, "SWITCH: Case studies in the demand side management of washing appliances" *Energy Procedia*, vol. 42, pp. 153-162, 2013.
- [13] United Kingdom. *Climate Change Act 2008 – Chapter 27*. [Online] Available: [http://www.legislation.gov.uk/ukpga/2008/27/pdfs/ukpga\\_20080027\\_en.pdf](http://www.legislation.gov.uk/ukpga/2008/27/pdfs/ukpga_20080027_en.pdf) [Accessed: 28 January 2014]
- [14] S. J. DeCanio and A. Fremstad, "Economic feasibility of the path to zero net carbon emissions" *Energy Policy*, vol. 39, pp. 1144-1153, 2011.
- [15] United Nations. Department of Economic and Social Affairs. Population Division, *World Population Prospects: The 2012 Revision, Highlights and Advance Tables*. New York: United Nations, 2013.
- [16] United Kingdom. DECC, *Energy Flow Chart 2012*. London: DECC, 2013. [Online] Available: [https://www.gov.uk/government/uploads/system/uploads/attachment\\_data/file/224122/energy\\_flow\\_chart\\_2012.PDF](https://www.gov.uk/government/uploads/system/uploads/attachment_data/file/224122/energy_flow_chart_2012.PDF) [Accessed: 27 February 2014].
- [17] Ofgem, "Electricity Capacity Assessment Report 2013" London, UK, Rep. 105/13, 2013.
- [18] United Kingdom. DECC, "Fuel Poverty Report – Updated August 2013", London, UK, Rep. URN13D/214, 2013.
- [19] National Right to Fuel Campaign, *TOO BIG TO BE WARM: FUEL POVERTY AND UNDER-OCCUPANCY IN PRIVATE HOMES*, London, UK, 2012.
- [20] United Kingdom. HM Treasury, "Pre-Budget Report – Investing in Britain's potential: Building our long-term future", London, UK, Rep. CM6984, 2006.

- [21] United Kingdom. HM Treasury, "Budget 2013", London, UK, Rep. HC1033, 2013.
- [22] United Kingdom. Department for Communities and Local Government, *Code for Sustainable Homes: A step-change in sustainable home building practice*. London: Department for Communities and Local Government, 2006.
- [23] United Kingdom. DECC, "Feed-in Tariffs: Government's Response to the Summer 2009 Consultation", London, UK, 2010.
- [24] United Kingdom. House of Commons. Energy and Climate Change Committee, "The Green Deal: watching brief – First Report of Session 2013-14", vol. 1, London, UK, Rep. HC142, 2013.
- [25] Green Alliance, "The power of negawatts", London: Park Lane Press, 2012. [Online] Available: [http://issuu.com/greenallianceuk/docs/the\\_power\\_of\\_negawatts/8?e=1948230/3366483](http://issuu.com/greenallianceuk/docs/the_power_of_negawatts/8?e=1948230/3366483) [Accessed: 27 February 2014].
- [26] National Grid. Historical Demand Data. [Online] Available: [www2.nationalgrid.com/WorkArea/DownloadAsset.aspx?id=28567](http://www2.nationalgrid.com/WorkArea/DownloadAsset.aspx?id=28567) [Accessed: 27 February 2014].
- [27] Elexon. Balancing Mechanism Reporting System. Historical System Prices Data. [Online] Available: <http://www.bmreports.com/bsp/SystemPricesHistoric.htm> [Accessed: 27 February 2014]
- [28] J. Constable and L. Moroney, "High Rewards for Wind Farms Discarding Electricity 5-6<sup>th</sup> April 2011", Renewable Energy Foundation, 2011. [Online] Available: <http://www.ref.org.uk/attachments/article/231/ref%20info%20note%2001%2005%2011.pdf> [Accessed: 27 February 2014].
- [29] I. Richardson, M. Thomson and D. Infield, "A high-resolution domestic building occupancy model for energy demand simulations" *Energy and Buildings*, vol. 40, pp. 1560-1566, 2008.

- [30] "Electric Heating Costs", WordPress, [Online] Available: <http://electricheatingcosts.com/economy-7-or-economy-10-heatwise-tariff/> [Accessed: 27 February 2014].
- [31] Sustainable Energy Ireland, "A Scoping Study: Demand Side Measures for Small Business and Residential Customers on Ireland's Electrical System", Dublin, Ireland, 2005.
- [32] EA Technology, "Delivering the Benefits of Smart Appliances", Chester, UK, Rep. SPMT10\_043, 2011.
- [33] Energy Saving Trust, "Powering the Nation: Household electricity-using habits revealed", Energy Saving Trust, London, UK, June 2012.
- [34] A. Oxlade, "British Gas free electricity on Saturdays: 10 ways to take advantage", The Telegraph, 1 August 2013.
- [35] United Kingdom. DECC, "National Energy Efficiency Data-Framework", London, UK, Rep. URN13D/145, June 2013.
- [36] United Kingdom. DECC, "Energy Efficiency Statistical Summary", London, UK, Rep. URN12D/419, November 2012.
- [37] Energy Saving Trust, "The elephant in the living room: how our appliances and gadgets are trampling the green dream", Energy Saving Trust, London, UK, September 2011.
- [38] R. J. Meyers, E. D. Williams and H. S. Matthews, "Scoping the potential of monitoring and control technologies to reduce energy use in homes", *Energy and Buildings*, vol. 42, pp. 563-569, 2010.
- [39] D. Parker, D. Hoak and J. Cummings, "Pilot Evaluation of Energy Savings and Persistence from Residential Energy Demand Feedback Devices in a Hot Climate", *ACEEE Summer Study on Energy Efficiency in Buildings*, vol. 7, pp. 245-259, 2010.
- [40] S. Darby, "The effectiveness of feedback on energy consumption", Environmental Change Institute, University of Oxford, Oxford, UK, April 2006.
- [41] T. Hargreaves, M. Nye and J. Burgess, "Making energy visible: A qualitative field study of how householders interact

- with feedback from smart energy monitors”, *Energy Policy*, vol. 38, pp. 6111-6119, 2010.
- [42] J. Burgess and M. Nye, “Re-materialising energy use through transparent monitoring systems”, *Energy Policy*, vol. 36, pp. 4454-4459, 2008.
- [43] United Kingdom. DECC, “Smart Meters Programme”, London, UK, Rep. URN13D/103, 10 May 2013.
- [44] J. Giacomini and D. Bertola, “Human emotional response to energy visualisations”, *International Journal of Industrial Ergonomics*, vol. 42, pp. 542-552, 2010.
- [45] “‘Tough’ rules govern smart meter data sharing”, BBC, 10 April 2012. [Online] Available: <http://www.bbc.co.uk/news/technology-1766367> [Accessed: 27 February 2014].
- [46] A. Ernevi, S. Palm and J. Redström, “Erratic Appliances and Energy Awareness”, *Know Techn Pol*, vol. 20, pp. 71-78, 2007.
- [47] M. Alahmad, W. Nader, Y. Cho, J. Shi and J. Neal, “Integrating physical and virtual environments to conserve energy in buildings”, *Energy and Buildings*, vol. 43, pp. 3710-3717, 2011.
- [48] H. Wilhite and R. Ling, “Measured energy savings from a more informative energy bill”, *Energy and Buildings*, vol. 22, pp. 145-155, 1995.
- [49] R. Freeman and P. Gait, “Evaluation of CERT Demonstration Actions Related to Smart Meters – Analysis Methodology and Results”, sustain, Bristol, UK, 11 February 2013.
- [50] S. Karjalainen, “Consumer preferences for feedback on household electricity consumption”, *Energy and Buildings*, vol. 43, pp. 458-467, 2011.
- [51] S. Roberts, H. Humphries and V. Hyldon, “Consumer preferences for improving energy consumption feedback”, Centre for sustainable energy, Bristol, UK, Rep. Con/Spec/2004-2007, May 2004.



- [52] C. Fischer, "Feedback on household electricity consumption: a tool for saving energy?", *Energy Efficiency*, vol. 1, pp. 79-104, 2008.
- [53] G. Wood and M. Newborough, "Dynamic energy-consumption indicators for domestic appliances: environment, behaviour and design", *Energy and Buildings*, vol. 35, pp. 821-841, 2003.
- [54] P. Fox-Penner, *Smart Power, Climate Change, the Smart Grid, and the Future of Electric Utilities*, Washington DC: Island Press, 2010.
- [55] VTT, "Results from the EFFLOCOM Pilots", EC Restricted, Rep. EU/SAVE 132/01, 30 June 2004.
- [56] "British Gas plans to offer free power on Saturdays", BBC, 1 August 2013. [Online] Available: <http://www.bbc.co.uk/news/business-23526389> [Accessed: 27 February 2014].
- [57] A. Faruqui, D. Harris and R. Hledik, "Unlocking the €53 billion savings from smart meters in the EU: How increasing the adoption of dynamic tariffs could make or break the EU's smart grid investment", *Energy Policy*, vol. 38, pp. 6222-6231, 2010.
- [58] A. M. Ithal, H. S. Rajamani, R. A. Abd-Alhameed and M. K. Jalboub, "The influence of different tariffs schemes on electricity consumption for the UK domestic buildings", 8<sup>th</sup> International Multi-Conference on Systems, Signals & Devices, Sousse, Tunisia, 22 – 25 March 2011.
- [59] G. Peschiera and J. E. Taylor, "The impact of peer network position on electricity consumption in building occupant networks utilizing energy feedback systems", *Energy and Buildings*, vol. 49, pp. 584-590, 2012.
- [60] R. Kyrö, J. Heinonen and S. Junnila, "Housing managers key to reducing the greenhouse gas emissions of multi-family housing companies? A mixed method approach", *Building and Environment*, vol. 56, pp. 203-210, 2012.
- [61] D. Kahnemann, *Thinking, Fast and Slow*, London: Penguin Books, 2011.

- [62] R. Cox, S. B. Leeb, S. R. Shaw and L. K. Norford, "Transient Event Detection for Nonintrusive Load Monitoring and Demand Side Management Using Voltage Distortion", in Proceedings of 21<sup>st</sup> IEEE Applied Power Electronics Conference and Exposition, Dallas, Texas, pp. 1751-1757, 19 – 23 March 2006.
- [63] E. O. Heierman and D. J. Cook, "Improving Home Automation by Discovering Regularly Occurring Device Usage Patterns", in Proceedings of 3<sup>rd</sup> IEEE International Conference on Data Mining, Melbourne, Florida, pp. 537-540, November 2003.
- [64] J. W. Moon and J.-J. Kim, "ANN-based thermal control models for residential buildings", *Building and Environment*, vol. 45, pp. 1612-1625, 2010.
- [65] S. Abras, S. Pesty, S. Ploix and M. Jacomino, "An Anticipation Mechanism for Power Management in a Smart Home using Multi-Agent Systems", 3<sup>rd</sup> International Conference on Information and Communication Technologies: From Theory to Application, Damascus, Syria, April 2008.
- [66] S. Karjalainen and V. Lappalainen, "Integrated control and user interfaces for a space", *Building and Environment*, vol. 46, pp. 938-944, 2011.
- [67] S. Castle, "2012 the Year of Smart Appliances?", GreenTech Advocates, 19 January 2012. [Online] Available: <http://greentechadvocates.com/2012/01/19/2012-the-year-of-smart-appliances/> [Accessed: 27 February 2014].
- [68] Y.-J. Lin, H. A. Latchman and M. Lee, "A Power Line Communication Network Infrastructure for The Smart Home", *IEEE Wireless Communications*, vol. 9, no. 6, pp. 104-111, 2002.
- [69] L. Xie, Y. Shi, Y. T. Hou and H. D. Sherali, "Making Sensor Networks Immortal: An Energy-Renewal Approach With Wireless Power Transfer", *IEEE/ACM Transactions on Networking*, vol. 20, no. 6, December 2012.
- [70] IEEE Standard for Local and metropolitan area networks - Part 15.4: Low-Rate Wireless Personal Area Networks (LR-WPANs), IEEE Standard 802.15.4-2011, 2011.

- [71] W. S. Lee and S. H. Hong, "KNX – ZigBee Gateway for Home Automation", in Proceedings of 4<sup>th</sup> IEEE Conference on Automation Science and Engineering, Washington DC, USA, pp. 750-755, 23 – 26 August 2008.
- [72] B. Bordass, A. Leaman and R. Bunn, "Controls for End Users: a guide for good design and implementation", Building Controls Industry Association, Reading, UK, May 2007.
- [73] R. Critchley, J. Gilbertson, M. Grimsley, G. Green and Warm Front Study Group, "Living in cold homes after heating improvements: Evidence from Warm-Front, England's Home Energy Efficiency Scheme", *Applied Energy*, vol. 84, pp. 147-158, 2007.
- [74] M. Treberspurg, R. Smutny et al., "Nachhaltigkeits-monitoring ausgewählter Passivhaus-Wohnanlagen in Wien", Universität für Bodenkultur Wien, Vienna, Austria, December 2009.
- [75] K. M. A. Revell and N. A. Stanton, "Case studies of mental models in home heat control: Searching for feedback, valve, timer and switch theories", *Applied Ergonomics*, vol. 45, no. 3, pp. 363-378, May 2014.
- [76] D. Norman, *Emotional Design: Why We Love (or Hate) Everyday Things*, New York: Basic Books, 2004.
- [77] J. Toftum, "Central automatic control or distributed occupant control for better indoor environment quality in the future", *Building and Environment*, vol. 45, pp. 23-28, 2010.
- [78] R. Parasuraman and V. Riley, "Humans and Automation: Use, Misuse, Disuse, Abuse", *Human Factors*, vol. 39, no. 2, pp. 230-253, 1997.
- [79] S. M. Merritt, H. Heimbaugh, J. LaChapell and D. Lee, "I Trust It, but I Don't Know Why: Effects of Implicit Attitudes Toward Automation on Trust in an Automated System", *Human Factors*, vol. 55, no. 3, pp. 520-534, June 2013.
- [80] R. J. Cole and Z. Brown, "Human and Automated Intelligence in Comfort Provisioning", 26<sup>th</sup> Conference on Passive and Low Energy Architecture, Quebec, Canada, 22 – 24 June 2009.

- [81] M. R. Endsley, "Automation and Situation Awareness", in R. Parasuraman and M. Mouloua (Eds.), *Automation and human performance: Theory and applications*, Mahwah: Lawrence Erlbaum, pp. 163-181, 1996.
- [82] M. Klos and J. Erickson, "Communicating Thermostats for Residential Time-of-Use Rates: They Do Make a Difference", *ACEEE Summer Study on Energy Efficiency in Buildings*, vol. 7, pp. 179-190, 2008.
- [83] L. Bartram and R. Woodbury, "Smart Homes or Smart Occupants? Reframing Computational Design Models for the Green Home", *Artificial Intelligence and Sustainable Design – Papers from the 2011 AAAI Spring Symposium*, Stanford, California, 21 – 23 March 2011.
- [84] P. J. Boait and R. M. Rylatt, "A method for fully automatic operation of domestic heating", *Energy and Buildings*, vol. 42, pp. 11-16, 2010.
- [85] O. Mejri, E. P. D. Barrio and N. Ghrab-Morcos, "Energy performance assessment of occupied buildings using model identification techniques", *Energy and Buildings*, vol. 43, pp. 285-299, 2011.
- [86] Z. J. Yu, F. Haghighat, B. C. M. Fung, E. Morofsky and H. Yoshino, "A methodology for identifying and improving occupant behaviour in residential buildings", *Energy*, vol. 36, pp. 6596-6608, 2011.
- [87] "Warning over smart meters privacy risk", BBC, 12 June 2012. [Online] Available: <http://www.bbc.co.uk/news/technology-18407340> [Accessed: 27 February 2014]
- [88] S. Helal, W. Mann, H. El-Zabadani, J. King, Y. Kaddoura and E. Jansen, "The Gator Tech Smart House: A Programmable Pervasive Space", *IEEE Computer Society*, vol. 38, no. 3, pp. 50-60, March 2005.
- [89] A. J. Wilson, "Device-free localization with received signal strength measurements in wireless networks", PhD dissertation, Department of Electrical and Computer

- Engineering, University of Utah, Salt Lake City, Utah, August 2010.
- [90] Jennic, "JenNet Stack User Guide", NXP Laboratories UK, Sheffield, UK, Rep. JN-UG-3041, 28 September 2010
- [91] JennicGordon, "re: Significance Of LQI?", Forum: Application Development, 3 March 2008. [Online] Available: <http://www.jennic.com/support/forums/thread.php?postID=000003470> [Accessed: 27 February 2014].
- [92] S. Meyn, A. Surana, Y. Lin, S. M. Oggianu, S. Narayanan, T. A. Frewen, "A Sensor-Utility-Network Method for Estimation of Occupancy Distribution in Buildings", in Proceedings of 48<sup>th</sup> IEEE Conference on Decision and Control, Shanghai, China, 15 – 18 December 2009.
- [93] S. J. Emmerich and A. K. Persily, "State-of-the-Art Review of Co2 Demand Controlled Ventilation Technology and Application", Nation Institute of Standards and Technology, Rep. NISTIR6729, 2001.
- [94] T. Leephakpreeda, R. Thitipatanapong, T. Grittiychot and V. Yungchareon, "Occupancy-Based Control of Indoor Air Ventilation: A Theoretical and Experimental Study", *ScienceAsia*, vol. 27, pp. 279-284, 2001.
- [95] T. Lu, A. Knuutila, M. Viljanen and X. Lu, "A novel methodology for estimating space air change rates and occupant CO<sub>2</sub> generation rates from measurements in mechanically-ventilated buildings", *Building and Environment*, vol. 45, pp. 1161-1172, 2010.
- [96] S. Wang, J. Burnett and H. Chong, "Experimental Validation of CO<sub>2</sub>-Based Occupancy Detection for Demand-Controlled Ventilation", *Indoor and Built Environment*, vol. 8, pp. 377-391, 1999.
- [97] C.-A. Roulet and F. Foradini, "Simple and Cheap Air Change Rate Measurement Using CO<sub>2</sub> Concentration Decays", *International Journal of Ventilation*, vol. 1, no. 1, pp. 39-44, 2002.
- [98] M. J. Akhlaghinia, A. Lotfi, C. Langensiepen and N. Sherkat, "Occupancy Monitoring in Intelligent Environment through

- Integrated Wireless Localizing Agents”, in Proceedings of IEEE Symposium on Intelligent Agents, Nashville, USA, pp. 70-76, 30 March – 2 April 2009.
- [99] H. T. Friis, “A Note on a Simple Transmission Formula”, *Proceedings of the IRE*, vol. 34, no. 5, pp. 254-256, May 1946.
- [100] D. Lymberopoulos, Q. Lindsey and A. Savvides, “An Empirical Characterization of Radio Signal Strength Variability in 3-D IEEE 802.15.4 Networks Using Monopole Antennas”, in *Wireless Sensor Networks*, K. Römer, H. Karl, F. Mattern, Eds. Berlin: Springer, pp. 326-341, 2006.
- [101] J. C. Stein, “Indoor Radio WLAN Performance Part II: Range Performance in a Dense Office Environment”, Harris Semiconductor, Florida, USA, 1997.
- [102] A. Shamir, “An Introduction to Radio Waves Propagation: Generic Terms, Indoor Propagation and Practical Approaches to Path Loss Calculations, Including Examples”, RFWaves Ltd, Or-Yehuda, Israel, 2002.
- [103] R. Wilson, “Propagation Losses Through Common Building Materials: 2.4 GHz vs 5 GHz”, UltraLab, University of Southern California, Los Angeles, California, Rep. E10589, August 2002.
- [104] M. J. Schroeder, A. Sadasiva and R. M. Nelson, “An Analysis on the Role of Water Content and State on Effective Permittivity Using Mixing Formulas”, *Biomechanics, Biomedical and Biophysical Engineering*, vol. 2, no. 1, pp. 1-11, 2008.
- [105] M. Seifeldin and M. Youssef, “A Deterministic Large-Scale Device-Free Passive Localization System for Wireless Environments”, 3<sup>rd</sup> International Conference on Pervasive Technologies Related to Assistive Environments, Samos Greece, 23 – 25 June 2010.
- [106] A. E. Kosba, A. Abdelkader and M. Youssef, “Analysis of a Device-free Passive Tracking System in Typical Wireless Environments”, 3<sup>rd</sup> International Conference on New

- Technologies, Mobility and Security, Cairo, Egypt, 20 – 23 December 2009.
- [107] A. E. Kosba, A. Saeed and M. Youssef, "RASID: A Robust WLAN Device-free Passive Motion Detection System", arXiv:1105.6084, 30 May 2011.
- [108] M. Moussa and M. Youssef, "Smart Devices for Smart Environments: Device-free Passive Detection in Real Environments", IEEE International Conference on Pervasive Computing and Communications, Galveston, Texas, 9 – 13 March 2009.
- [109] A. Eleryan, M. Elsabagh and M. Youssef, "AROMA: Automatic Generation of Radio Maps for Localization Systems", arXiv:1002.1834, 9 February 2010.
- [110] D. Zhang, J. Ma, Q. Chen and L. M. Ni, "An RF-based System for Tracking Transceiver-free Objects", in Proceedings of 5<sup>th</sup> Annual IEEE International Conference on Pervasive Computing and Communications, New York, USA, pp. 135-144, 19 – 23 March 2007.
- [111] D. Zhang and L.M. Ni, "Dynamic Clustering for Tracking Multiple Transceiver-free Objects", in Proceedings of 7<sup>th</sup> Annual IEEE International Conference on Pervasive Computing and Communications, Galveston, Texas, 9 – 13 March 2009.
- [112] D. Lieckfeldt, J. You and D. Timmermann, "Characterizing the Influence of Human Presence on bistatic passive RFID-System", IEEE International Conference on Wireless and Mobile Computing, Networking and Communications, Marrakech, Morocco, 12 – 14 October 2009.
- [113] J. Wilson and N. Patwari, "Radio Tomographic Imaging with Wireless Networks", SPAN lab, University of Utah, Salt Lake City, Utah, 17 September 2008
- [114] J. Wilson, N. Patwari and F. G. Vasquez, "Regularization Methods for Radio Tomographic Imaging", 2009 Virginia Tech Wireless Symposium, Blacksburg, Virginia, 3 – 5 June 2009.
- [115] M. A. Kanso and M. G. Rabbat, "Compressed RF Tomography for Wireless Sensor Networks: Centralized and Decentralized

- Approaches", in *Distributed Computing in Sensor Systems*, B. Krishnamachari, S. Suri, W. Heinzelman, U. Mitra, Eds. Berlin: Springer, pp. 173-186, 2009.
- [116] O. Kaltikallio, M. Bocca and L. M. Eriksson, "Poster Abstract: Distributed RSSI Processing for Intrusion Detection in Indoor Environments", 9<sup>th</sup> ACE/IEEE International Conference on Information Processing in Sensor Networks, Stockholm, Sweden, 12 – 16 April 2010.
- [117] K. Woyach, D. Puccinelli and M. Haenggi, "Sensorless Sensing in Wireless Networks: Implementation and Measurements", 4<sup>th</sup> International Symposium on Modelling and Optimization in Mobile, Ad Hoc and Wireless Networks, 3 – 6 April 2006.
- [118] P. W. Q. Lee, W. K. G. Seah, H.-P. Tan, Z. Yao, "Wireless sensing without sensors – an experimental study of motion/intrusion detection using RF irregularity", *Measurement Science and Technology*, vol. 21, pp. 1-7, 2010.
- [119] J. Wilson and N. Patwari, "Through-Wall Motion Tracking Using Variance-Based Radio Tomography Networks", SPAN Lab, University of Utah, Salt Lake City, Utah, arXiv:0909.5417, 1 October 2009.
- [120] X. Chen, A. Edelstein, Y. Li, M. Coates, M. Rabbat and A. Men, "Sequential Monte Carlo for Simultaneous Passive Device-Free Tracking and Sensor Localization Using Received Signal Strength Measurements", 10<sup>th</sup> International Conference on Information Processing in Sensor Networks, Chicago, Illinois, 12 -14 April 2011.
- [121] F. Viani, L. Lizzi, P. Rocca, M. Benedetti, M. Donelli and A. Massa, "Object tracking through RSSI measurements in wireless sensor networks", *Electronics Letters*, vol. 44, no. 10, 8 May 2008.
- [122] J. Yang, Y. Ge, H. Xiong, Y. Chen and H. Liu, "Performing Joint Learning for Passive Intrusion Detection in Pervasive Wireless Environments", IEEE INFOCOM 2010, Los Angeles, California 15 – 19 March 2010.



- [123] S. Hussain, R. Peters and D. L. Silver, "Using Received Signal Strength Variation for Surveillance in Residential Areas", in Proceedings of Data Mining, Intrusion Detection, Information Assurance, and Data Network Security 2008, vol. 6973, March 2008.
- [124] Q. Yao, H. Gao, B. Liu and F.-Y. Wang, "Poster Abstract: MODEL – Moving Object DEtection and Localization in Wireless Networks Based on Small-Scale Fading", in Proceedings of 6<sup>th</sup> ACM Conference on Embedded Networked Sensor Systems, Raleigh, North Carolina, pp. 451-452, 5 – 7 November 2008.
- [125] M. Nakatsuka, H. Iwatani and J. Katto, "A Study on Passive Crowd Density Estimation using Wireless Sensors", 4<sup>th</sup> International Conference on Mobile Computing and Ubiquitous Networking, Tokyo, Japan, 11 – 13 June 2008.
- [126] N. Patwari and J. Wilson, "People-Sensing Spatial Characteristics of RF Sensor Networks", SPAN Lab, University of Utah, Salt Lake City, Utah, arXiv:0911.1972, 10 November 2009.
- [127] P. Vance, G. Prasad, J. Harkin and K. Curran, "Analysis of Device-free Localisation (DFL) Techniques for Indoor Environments", in Proceedings of IET Irish Signals and Systems Conference, Cork, Ireland, pp. 76-81, 23 – 24 June 2010.
- [128] S. Wang, N. Chen, X. Chen, J. Yang and J. Lu, "LWOS: A Localization Method Without On-Body Sensor in Wireless Sensor Networks", in *Emerging Directions in Embedded and Ubiquitous Computing*, X. Zhou et al. Eds. Berlin: Springer, pp. 495-504, 2006.
- [129] T. H. Uchida, W. R. Smith, C. Murphy and C. R. Anderson, "Development of a Passive Wireless Surveillance Network", Virginia Tech Symposium on Wireless Personal Communication, Blacksburg, Virginia, 2 – 4 June 2010.
- [130] D. Christmann, I. Martinovic and J. B. Schmitt, "Analysis of transmission properties in an indoor wireless sensor network based on a full-factorial design", *Measurement Science and Technology*, vol. 21, pp. 1-12, 2010.

- [131] IEEE Standard for Safety Levels with Respect to Human Exposure to Radio Frequency Electromagnetic Fields, 3 kHz to 300 GHz, IEEE Std C95.1, 1999.
- [132] ICNIRP, "ICNIRP Guidelines for limiting exposure to time-varying electric, magnetic and electromagnetic fields (up to 300 GHz)", *Health Physics*, vol. 74, no. 4, pp. 494-522, 1998.
- [133] World Health Organization, *Electromagnetic Hypersensitivity*, K. H. Mild, M. Repacholi, E. v. Deventer, P. Ravazzani, Eds. Milan: WHO Press, June 2006.
- [134] S. Radosavac, "Intrusion detection for defense at the MAC and routing layers of wireless networks", PhD dissertation, Department of Electrical and Computer Engineering, University of Maryland, College Park, Maryland, 2007.
- [135] Texas Instruments, "CC1100/CC1150DK, CC1101DK, and CC2500/CC2550DK: Development Kit User Manual", Dallas, Texas, Rep. SWRU040C, 2007.
- [136] Texas Instruments, "Low-Power Sub-1 GHz RF Transceiver", Dallas, Texas, Rep. SWRS061I, 2014. [Online] Available: <http://www.ti.com/lit/ds/symlink/cc1101.pdf> [Accessed: 27 February 2014].
- [137] Chipcon, "2.4 GHz IEEE 802.15.4 / ZigBee-ready RF Transceiver", Rep. SWRS041, 2006. [Online] Available: <http://www-mtl.mit.edu/Courses/6.111/labkit/datasheets/CC2420.pdf> [Accessed: 27 February 2014].
- [138] Crossbow Technology Inc., "TelsoB mote platform", San Jose, California [Online] Available: [http://www.willow.co.uk/TelosB\\_Datasheet.pdf](http://www.willow.co.uk/TelosB_Datasheet.pdf) [Accessed: 27 February 2014].
- [139] K. Srinivasan and P. Levis, "RSSI is Under Appreciated", 3<sup>rd</sup> Workshop on Embedded Networks Sensors, May 2006.
- [140] J. Sauro and J. R. Lewis, "When Designing Usability Questionnaires, Does It Hurt to Be Positive?", in Proceedings of SIGCHI Conference on Human Factors in Computing Systems, Vancouver, Canada, pp. 2215-2224, 7 – 12 May 2011.

- [141] University of Nottingham, "Creative Energy Homes", [Online] Available: <http://www.nottingham.ac.uk/creative-energy-homes/creative-energy-homes.aspx> [Accessed: 27 February 2014].

## APPENDIX A HOUSEHOLD ELECTRICITY USE SURVEY DATA

The data depicted in this table was sourced from the Household Electricity Use Survey [8]. It excludes space heating and assumes an energy price of 14.5 pence per kWh. Appliances, which had less than 25 representative samples, are marked with a “\*”.

Appliance Category	Mean Consumption per Household (kWh/year)	Appliance	Mean Consumption per Appliance (kWh/year)	Mean Running Cost (£/year)	Mean Savings (kWh/year)
Cold	540	Freezer (Chest)	362.0	52.49	184
		Freezer (Upright)	327.0	47.42	155
		Fridge-Freezer	427.0	61.92	271
		Refrigerator	162.0	23.49	79
Computing	240	Desktop	166.0	24.07	
		Fax/Printer*	160.0	23.20	
		Hard-drive*	12.2	1.77	
		Laptop	29.0	4.21	117
		Modem*	61.8	8.96	
		Monitor	42.4	6.15	
		Multifunctional Printer*	26.5	3.84	
		Printer	20.7	3.00	

APPENDIX A: HOUSEHOLD ELECTRICITY USE SURVEY DATA

		Router	58.2	8.44	
		Scanner*	20.0	2.90	
		TV (CRT)	118.0	17.11	
		TV (LCD)	199.0	28.86	
		TV (Plasma)*	658.0	95.41	
		TV + DVD	55.6	8.06	
		TV + DVD + Set-Top Box*	462.5	67.06	
		TV + DVD + VCR*	147.8	21.43	
		TV + Set-Top Box*	244.3	35.42	
		TV + VCR*	32.8	4.76	
		Aerial*	24.5	3.55	
Consumer Electronics	553	Audio-visual Receiver*	1025.8	148.74	
		Blu-ray Player*	8.4	1.22	
		CD Player*	34.7	5.03	
		DVD Recorder*	96.8	14.04	
		DVD	36.6	5.31	
		DVD + VCR*	59.5	8.63	
		Games Console	47.6	6.90	
		Hi-Fi*	107.0	15.52	
		Home Cinema Sound*	54.5	7.90	
		PlayStation2*	40.8	5.92	
		PlayStation3*	67.7	9.82	100

APPENDIX A: HOUSEHOLD ELECTRICITY USE SURVEY DATA

---

		Radio*	35.5	5.15
		Set-Top Box	115.2	16.70
		Set-Top Box (Brand)	148.8	21.58
		Speakers*	31.0	4.50
		TV Booster*	3.8	0.55
		VCR	48.3	7.00
		Video Sender*	22.3	3.23
		Wii*	39.8	5.77
		Xbox*	32.8	4.76
		Xbox 360*	56.6	8.21
		Bread Maker*	23.6	3.42
		Bottle Warmer*	27.2	3.94
		Coffee Machine*	31.8	4.61
		Cooker	317.0	45.97
		Extractor Hood	11.7	1.70
		Food Mixer*	0.5	0.07
Cooking	460	Food Steamer*	52.7	7.64
		Fryer*	52.0	7.54
		Grill*	12.8	1.86
		Hob*	226.0	32.77
		Kettle	167.0	24.22
		Microwave	56.0	8.12

APPENDIX A: HOUSEHOLD ELECTRICITY USE SURVEY DATA

	Oven	290.0	42.05	
	Toaster	21.9	3.18	
	Yoghurt Maker*	8.0	1.16	
Lighting	Lighting	537.0	77.87	58
	Air Conditioning*	41.7	6.05	
	Aquarium*	278.1	40.32	
	Baby Monitor*	8.8	1.28	
	Charger*	26.0	3.77	
	Clock Radio*	19.9	2.89	
	Cordless Phone*	25.3	3.67	
	Dehumidifier*	525.3	76.17	
	Digital Picture Frame*	15.2	2.20	
Other	Door Bell*	52.4	7.60	
	Electric Blanket*	13.7	1.99	
	Electric Chair*	13.3	1.93	
	Fan*	46.1	6.68	
	Hair Dryer	19.6	2.84	
	Hair Straightener	4.0	0.58	
	House Alarm*	66.6	9.66	
	Iron	31.2	4.52	
	Massage Bed*	215.1	31.19	
	Organ*	7.3	1.06	

APPENDIX A: HOUSEHOLD ELECTRICITY USE SURVEY DATA

		Paper Shredder*	2.3	0.33	
		Pond Pump*	218.6	31.70	
		Sewing Machine*	6.9	1.00	
		Smoke Detector*	0.6	0.09	
		Steriliser*	42.6	6.18	
		Sunbed*	0.2	0.03	
		Trouser Press*	11.8	1.71	
		Vacuum Cleaner	18.1	2.62	
		Vivarium*	56.7	8.22	
Water Heating	418	Electric Shower	350.5	50.82	
		Immersion Heater*	378.8	54.93	
		Clothes Dryer	394.0	57.13	191
Wet		Dishwasher	294.0	42.63	88
		Washer-Dryer*	243.0	35.24	
		Washing Machine	166.0	24.07	9



## APPENDIX B USER PERCEPTION QUESTIONNAIRE

### Domestic Energy Saving Technology



---

#### Welcome

This questionnaire is designed to understand people's views on energy saving measures, in particular the use of a domestic automation system and a new domestic tracking technology called Device-free Localisation. This survey is part of the University of Nottingham's research into energy savings in the domestic environment. The findings will influence the design of potential domestic energy saving automation systems.

The survey is completed anonymously. It has 15 questions and should take around 5 minutes to complete.

All data collected in this survey will be held anonymously and securely. It will only be used for research purposes and related publications. Personal data stored by your Web browser is not used in this survey.

If you have any further questions, please contact Eldar Nagijew via this email address (it will also be displayed at the end of the survey):

[laxen1@nottingham.ac.uk](mailto:laxen1@nottingham.ac.uk)

[Continue >](#)

## Domestic Energy Saving Technology



The University of  
**Nottingham**

### Perception of Domestic Energy Saving Technologies

Questions are **mandatory** unless marked otherwise. Some questions have a "More Info" button next to it to give further detail about that question.

Note that once you have clicked on the CONTINUE button your answers are submitted and you can not return to review or amend that page.

#### Background Information

1. In which type of accommodation do you currently live?

[More Info](#)

Rented  Owned

Other (*please specify*):

It is a:

Flat / Apartment

Terraced House

Semi-detached House

Detached House

Bungalow

Other (*please specify*):

## APPENDIX B: USER PERCEPTION QUESTIONNAIRE

---

2. How many people excluding yourself do you live with?

Select an answer ▼

3. Do you know the approximate age of the house you live in?

Yes  No

It was built around:

### Energy Savings

4. How do you perceive current energy prices?

- Very Expensive
- Expensive
- Average
- Cheap
- Very Cheap

5. How often do you take energy saving measures (e.g. turning the thermostat down, switching the lights off)?

- Very often
- Relatively often
- Sometimes
- Rarely
- Never

## APPENDIX B: USER PERCEPTION QUESTIONNAIRE

---

6. What encourages you foremost to save energy?

- Reduce energy costs
- Protect the environment
- Both options equally
- Other (*please specify*):

7. In general, would you let an automated system handle potential energy savings in your house?

- Yes
- Depends
- No

Any particular reason? (*Optional*)

APPENDIX B: USER PERCEPTION QUESTIONNAIRE

8. For both scenarios, which type of savings would you...

	...do yourself?			Any Comment?	...let an automated system handle?			Any Comment?
	Yes	Occasionally	No		Yes	Don't mind	No	
<b>a.</b> Switch lights off in unoccupied rooms.	<input type="radio"/>	<input type="radio"/>	<input type="radio"/>	<input type="text"/>	<input type="radio"/>	<input type="radio"/>	<input type="radio"/>	<input type="text"/>
<b>b.</b> Adjust the heating to only heat occupied rooms.	<input type="radio"/>	<input type="radio"/>	<input type="radio"/>	<input type="text"/>	<input type="radio"/>	<input type="radio"/>	<input type="radio"/>	<input type="text"/>
<b>c.</b> Turn the heating off/down when you go on holiday.	<input type="radio"/>	<input type="radio"/>	<input type="radio"/>	<input type="text"/>	<input type="radio"/>	<input type="radio"/>	<input type="radio"/>	<input type="text"/>
<b>d.</b> Only switch the bathroom ventilation on when necessary.	<input type="radio"/>	<input type="radio"/>	<input type="radio"/>	<input type="text"/>	<input type="radio"/>	<input type="radio"/>	<input type="radio"/>	<input type="text"/>
<b>e.</b> Delay the start of white goods (e.g. washing machine, dishwasher) to when the energy price is cheaper.	<input type="radio"/>	<input type="radio"/>	<input type="radio"/>	<input type="text"/>	<input type="radio"/>	<input type="radio"/>	<input type="radio"/>	<input type="text"/>
<b>f.</b> Switch the TV off if no one is watching.	<input type="radio"/>	<input type="radio"/>	<input type="radio"/>	<input type="text"/>	<input type="radio"/>	<input type="radio"/>	<input type="radio"/>	<input type="text"/>
<b>g.</b> Switch the power socket off once the appliance (e.g. kettle, charger) isn't used anymore.	<input type="radio"/>	<input type="radio"/>	<input type="radio"/>	<input type="text"/>	<input type="radio"/>	<input type="radio"/>	<input type="radio"/>	<input type="text"/>

## APPENDIX B: USER PERCEPTION QUESTIONNAIRE

---

9. Do you generally trust automated systems to make the right decisions?

Yes  Depends  No

Any particular reason? *(Optional)*

### Suggested Energy Saving Technology Add-On

Automated systems have the potential to save energy, which occupants wouldn't be able to save (e.g. adjusting the heating or hot water 24/7). However, their operation could interfere with the occupant's actions and comfort. To prevent that from happening automated control systems would need to know the occupants' whereabouts. A localisation technology suited to the domestic environment is Device-free Localisation. It measures the strength of radio signals to determine the position of occupants and doesn't require them to wear any kind of tag or device. The strength of the used signals is 20 times less than the strength of a typical mobile phone signal.

APPENDIX B: USER PERCEPTION QUESTIONNAIRE

10. Please rate the following statements.

						Any Comment?
	Agree	Partially Agree	Neither Agree nor Disagree	Partially Disagree	Disagree	
a. I don't mind being wirelessly tracked in general.	<input type="radio"/>	<input type="radio"/>	<input type="radio"/>	<input type="radio"/>	<input type="radio"/>	<input type="text"/>
b. I wouldn't mind being tracked in my own house.	<input type="radio"/>	<input type="radio"/>	<input type="radio"/>	<input type="radio"/>	<input type="radio"/>	<input type="text"/>
c. I wouldn't mind being tracked in someone else's house.	<input type="radio"/>	<input type="radio"/>	<input type="radio"/>	<input type="radio"/>	<input type="radio"/>	<input type="text"/>
d. I don't have health concerns when using mobile phones or wireless LAN (WiFi).	<input type="radio"/>	<input type="radio"/>	<input type="radio"/>	<input type="radio"/>	<input type="radio"/>	<input type="text"/>
e. I wouldn't have health concerns about being tracked using radio signals.	<input type="radio"/>	<input type="radio"/>	<input type="radio"/>	<input type="radio"/>	<input type="radio"/>	<input type="text"/>

## APPENDIX B: USER PERCEPTION QUESTIONNAIRE

---

**11.** If you lived in a house, where you were being tracked in order to save energy; which type of tracking would you prefer?

Tag-based  Tag-less

Who would you like the data to be visible to? *(select all that apply)*

- Nobody
  - Yourself
  - Other people living in the house
  - Maintenance Company
  - Energy Company
  - Research Institutes
  - Government
  - Third Parties
- 

**12.** How many years would the payback period of such a system need to be for you to consider purchasing it?

[More Info](#)

- 1 - 2
- 3 - 5
- 5 - 10
- 10 - 20
- > 20



### Demographic Information

13. I am

Female  Male

14. My age is

Select an answer ▼

15. My occupation is  
(select all that apply)

Professional

Student

Retired

Other (please specify):

Continue >

## Domestic Energy Saving Technology



The University of  
**Nottingham**

---

### Final Page

#### **Thank you for taking part in this survey**

If you have any questions or would like to get further information about the outcome of this study, please contact Eldar Nagijew via this email address:

[laxen1@nottingham.ac.uk](mailto:laxen1@nottingham.ac.uk)

## **APPENDIX C      PRE-CASE STUDY INTERVIEW QUESTIONS**

### EXISTING BEHAVIOUR

- When do you currently use the dishwasher / washing machine?
- Do you typically use the same program, if so which one, or do you vary them?
- Do you coordinate with your housemates when using the appliance, or each use it separately?
- Is there someone in the household that typically takes charge of the dishwasher / washing machine?

### PRICE/ENVIRONMENTAL SENSITIVITY

- Would you currently consider your energy bills to be low, average or high?
- Do you consider cost, the environmental impact or both when using the dishwasher / washing machine?
- Have you ever done anything to try and reduce your energy bill or use – like change providers or limit usage?
- Do you currently or have you ever monitored your energy usage with an energy display?

### TECHNICAL LITERACY

- Do you feel confident using computers and other digital devices?
- What are your first impressions of the web interface?

### OVERALL INTEREST

- Can you see yourself using such a system on a daily basis?
- Do you have any concerns about using the system?
- Do you find anything appealing about the system?
- What would incentivise / encourage you to use such a system?

### PERSONAL

- What is your age?
- What is your profession?

## **APPENDIX D      POST-CASE STUDY INTERVIEW QUESTIONS**

### GENERAL

- Can you describe your experience of using the system?
- Is there anything you particularly liked/disliked?
- Did the system prompt you to change how you used the machine (e.g. programme choice or time of use)?

### HOUSEHOLD DYNAMICS

- How did you handle usage of the system among you and your guests?
- Did it ever prompt you to change your routine, or habits?
- Were there any disagreements? How did you handle those?
- Did the system provoke any particular discussions?

### ENHANCEMENTS

- Did the system work as expected?
- What could be done to enhance the system?
- What should be retained?

### CONTINUED USAGE

- Having now used the system, would you consider using it long term?
- What would need to be in place to encourage you to do so?
- How much would you need to save to continue using such as system?

- Would you allow others (e.g. government, private companies, charities, academic researchers) to access energy data that is stored by the system?