

Song, Yang (2014) Intelligent PID controller based on fuzzy logic control and neural network technology for indoor environment quality improvement. PhD thesis, University of Nottingham.

Access from the University of Nottingham repository:

http://eprints.nottingham.ac.uk/14300/1/Yang_PhD_Thesis.pdf

Copyright and reuse:

The Nottingham ePrints service makes this work by researchers of the University of Nottingham available open access under the following conditions.

This article is made available under the University of Nottingham End User licence and may be reused according to the conditions of the licence. For more details see:
http://eprints.nottingham.ac.uk/end_user_agreement.pdf

A note on versions:

The version presented here may differ from the published version or from the version of record. If you wish to cite this item you are advised to consult the publisher's version. Please see the repository url above for details on accessing the published version and note that access may require a subscription.

For more information, please contact eprints@nottingham.ac.uk



The University of
Nottingham

UNITED KINGDOM • CHINA • MALAYSIA

**Intelligent PID controller based on fuzzy logic
control and neural network technology for
indoor environment quality improvement**

Yang Song, BEng. MSc

Thesis submitted to the University of Nottingham

for the degree of Doctor of Philosophy

June 2014

ABSTRACT

The demand for better indoor environment has led to a wide use of heating, ventilating and air conditioning (HVAC) systems. Employing advanced HVAC control strategies is one of the strategies to maintain high quality indoor thermal comfort and indoor air quality (IAQ). This thesis aims to analyse and discuss the potential of using advanced control methods to improve the indoor occupants' comfort. It focuses on the development of controllers of the major factors of indoor environment quality in buildings including indoor air temperature, indoor humidity and indoor air quality.

Studies of the development of control technologies for HVAC systems are reviewed firstly. The problems in existing and future perspectives on HVAC control systems for occupants' comfort are investigated. As both the current conventional and intelligent controllers have drawbacks that limit their applications, it is necessary to design novel control strategies for the urgent issue of indoor climate improvement. Hence, a concept of designing the controllers for indoor occupants' comfort is proposed in this thesis. The proposed controllers in this research are designed by combining the conventional and intelligent control technologies. The purpose is to optimize the advantages of both conventional and intelligent control methods and to avoid poor control performance due to their drawbacks. The main control technologies involved in this research are fuzzy logic control (FLC), proportional-integral-derivative (PID) control and neural network (NN). Three controllers are designed by combining these technologies.

Firstly, the fuzzy-PID controller is developed for improvement of indoor environment quality including temperature, humidity and indoor air quality. The control algorithm is introduced in detail in Section 3.2. The computer simulation is carried out to verify its control performance and potential of indoor comfort improvement in Section 4.1. Step signal is used as the input reference in simulation and the controller shows fast response speed since the time constant is 0.033s and settling time is 0.092s with sampling interval of 0.001s. The simulating result also proves that the fuzzy-PID controller has good control accuracy and stability since the overshoot and steady state error is zero. In addition, the experimental investigation was also carried out to indicate the fuzzy-PID control performance of indoor temperature, humidity and CO₂ control as introduced in Chapter 5. The experiments are taken place in an environmental chamber used to simulated the indoor space during a wide period from late fall to early spring. The results of temperature control show that the temperature is controlled to be varying around the set-point and control accuracy is 4.4%. The humidity control shows similar results that the control accuracy is 3.2%. For the IAQ control the maximum indoor concentration is kept lower than 1100ppm which is acceptable and health CO₂ level although it is slightly

higher than the set-point of 1000ppm. The experimental results show that the proposed fuzzy-PID controller is able to improve indoor environment quality. A radial basis function neural network (RBFNN) PID controller is designed for humidity control and a back propagation neural network (BPNN) PID controller is designed for indoor air quality control.

Then, in order to further analyze the potential of using advanced control technologies to improve indoor environment quality, two more controllers are developed in this research. A radial basis function neural network (RBFNN) PID controller is designed for humidity control and a back propagation neural network (BPNN) PID controller is designed for indoor air quality control. Their control algorithms are developed and introduced in Section 3.3 and Section 3.4. Simulating tests were carried out in order to verify their control performances using Matlab in Section 4.2 and Section 4.3. The step signal is used as the input and the sampling interval is 0.001s. For RBFNN-PID controller, the time constant is 0.002s, and there is no overshoot and steady state error. For BPNN-PID controller, the time constant is 0.003s, the overshoot percentage is 4.2% and the steady state error is zero based on the simulating results. Simulating results show that the RBFNN-PID controller and BPNN-PID controller have fast control speed, good control accuracy and stability. The experimental investigations of the RBFNN-PID controller and BPNN-PID control are not included in this research and will be carried out in future work.

Based on the simulating and experimental results shown in this thesis, the indoor environment quality improvement can be guaranteed by the proposed controllers.

Key works: Control technology, fuzzy logic control, neural networks, back-propagation, indoor thermal comfort, indoor air quality

PUBLICATIONS

- Yang, S., Wu, S., Yan, Y.Y., 2013. Control strategies for indoor environment quality and energy efficiency—a review, *International Journal of Low-Carbon Technologies*, doi:10.1093/ijlct/ctt051.
- Song, Y., Wu, S., Yan, Y.Y., 2013. Development of Self-Tuning Intelligent PID Controller Based on BPNN for Indoor Air Quality Control, *International Journal of Emerging Technology and Advanced Engineering*, 3(11):283-290.

ACKNOWLEDGEMENTS

I would like to express my gratitude to my supervisor Professor Yuying Yan for his valuable support, encouragement and valuable advice on my research work during my PhD study period in the University of Nottingham. Together with the patient supervision, his constant support from academic publication to workshop training, helped me gain confidence and accumulate important experience, which all together made my whole PhD journey clear, positive and enjoyable. I also would like to thank Dr. shenyi Wu for his patient help on publication review and valuable advice on the research work and the technicians for their help on building test rig as well as my colleague Bo Li for his advice on various aspects.

I would like to express my love and gratitude to my dear loving parents for their countless love, financial and mental support and care in encouraging me to chase my dreams. Without them, I would not be where I am. I feel guilty to my parents that I have not come back to see them for years. However, I feel extremely grateful for their understanding and support.

My love and thanks also go to my dear wife who has taken care of me during my PhD study. She is always by my side and believes in me no matter what difficulties that I am facing.

Also many thanks to my good friends that I have got to know in the UK in the last four years, who have given me immense support and help in different aspects.

CONTENTS

ABSTRACT	i
PUBLICATIONS	iii
ACKNOWLEDGEMENTS	iv
CONTENTS	v
LIST OF TABLES	vii
LIST OF FIGURES	viii
NOMENCLATURES	xi
ABBREVIATIONS	xiii
Chapter 1 Introduction	1
1.1 Background	1
1.2 Aim and objectives	5
1.3 Research Methodology	9
1.4 Outline of thesis	12
Chapter 2 Literature review	15
2.1 Problem statements	15
2.1.1 Thermal comfort	16
2.1.2 Indoor air quality	22
2.1.3 Energy efficiency	26
2.2 Control technologies for HVAC systems	32
2.2.1 Performance improvement of HVAC systems with proper controllers	33
2.2.2 Control objectives	40
2.2.3 Conventional control	41
2.2.4 Computational intelligent control	49
2.3 Shortcomings of current control methods and future perspectives	64
2.4 Summary	66
Chapter 3 Controllers design	72
3.1 Mathematical model of indoor climate	73
3.1.1 Mathematical model of indoor temperature	74
3.1.2 Mathematical model of indoor humidity	76
3.1.3 Transfer matrix for indoor temperature and humidity	77
3.1.4 Mathematical model for indoor air quality (CO ₂)	79
3.2 Decoupling control strategy for temperature and humidity	79
3.3 Fuzzy-based PID controller	86
3.3.1 Structure of fuzzy-PID controller	86
3.3.2 PID control algorithm	87
3.3.3 Fuzzy block design	88
3.3.4 Summary of fuzzy-PID control	93
3.4 RBFNN- PID controller	95
3.4.1 Structure of RBFNN based PID controller	96

3.4.2	RBFNN algorithm for k_p , k_i , k_d regulation	97
3.4.3	PID control algorithm	101
3.4.4	Summary of RBFNN based PID control	101
3.5	BPNN-based PID controller	103
3.5.1	Structure of the BPNN-PID controller	103
3.5.2	PID control algorithm	104
3.5.3	BPNN algorithm	104
3.5.4	Summary of the BPNN-PID control strategy	111
3.6	Summary	113
Chapter 4 Simulation and Results		118
4.1	Simulation of fuzzy-PID controller	118
4.1.1	Test using step input	119
4.1.2	Fuzzy-PID control performance	124
4.2	Simulating tests of RBFNN-PID control	125
4.2.1	Response to step input	126
4.2.2	Response to square input	130
4.2.3	RBFNN-PID control performance	134
4.3	Simulating tests of BPNN-PID control	135
4.3.1	Response to step input	137
4.3.2	BPNN-PID control performance	142
4.4	Summary	143
Chapter 5 Experimental investigation		146
5.1	Experimental setup	146
5.2	Program of controller	152
5.3	Temperature control	159
5.4	Relative humidity	167
5.5	Carbon dioxide concentration	176
5.6	Summary	183
Chapter 6 Discussion, conclusion and future work		188
6.1	Discussion	188
6.1.1	Performance analysis based on theoretical and simulation analysis	188
6.1.2	Indoor environment improvement	192
6.1.3	Discussion of the concept of controller design	196
6.1.4	Contribution to knowledge	198
6.2	Conclusion	201
6.3	Future work	202
Reference		204
Appendix		225
Appendix A	Matlab code of fuzzy-PID control	226
Appendix B	Matlab code of RBFNN-PID control	232
Appendix C	Matlab code of BPNN-PID control	236
Appendix D	LabVIEW program diagram of fuzzy-PID control strategy	241

LIST OF TABLES

Table 1-1 Thermal comfort standard for individual countries [4]	2
Table 1-2 Ratio of thresholds for odour and sensory irritation for selected VOCs[6]	3
Table 1-3 Task list	11
Table 2-1 Recommended operative temperatures for occupants for sedentary activity based on ISO 7730–1984 [19].	19
Table 2-2 Recommended operative temperatures for occupants based on ASHRAE 55-1992 [19].	20
Table 2-3 A summary of works on thermal comfort standards [21]	21
Table 2-4 Frequent symptoms prevalence (%) from major studies in offices [6]	24
Table 2-5 Reported impact by odour [6]	25
Table 2-6 harm of CO ₂ on human body [7]	26
Table 2-7 Summary of energy savings in cooled buildings [20]	31
Table 2-8 Comparison of control systems [7]	70
Table 3-1 Effects of k_p , k_i and k_d tuning	89
Table 3-2 Fuzzy rule base of k_p	89
Table 3-3 Fuzzy rule base of k_i	90
Table 3-4 Fuzzy rule base of k_d	90
Table 5-1 Specification of humidity sensor	149
Table 5-2 Specification of CO ₂ sensor	149
Table 5-3 I/O module of controller	151

LIST OF FIGURES

Figure 1-1 The geographic distribution of building studies that formed the basis of the comfort standard of ASHRAE [3]	2
Figure 1-2 Breakdown structure of this research	9
Figure 1-3 Task path	12
Figure 2-1 (a) Residential buildings total energy end use (2010). (b) Commercial sector building energy end use (2010) [118, 119]	29
Figure 2-2 Simulink representations for the controlled thermal plant [160]	35
Figure 2-3 Simulink representation for a model predictive control structure [160]	35
Figure 2-4 Comparison between controlled and uncontrolled cases; (a) outlet temperature, (b) flow rate, and (c) boiler duty [160]	36
Figure 2-5 Accumulated boiler duty for controlled and uncontrolled cases [160]	37
Figure 2-6 Schematic of the liquid desiccant-based DOAS and its control system[161]	38
Figure 2-7 (a) Effect of the supply air flow rate on system COP. (b) Effect of ambient air temperature on system COP [161]	39
Figure 2-8 Typical PID structure	41
Figure 2-9 Block diagram of novel PID-based controller [180]	44
Figure 2-10 Comparison of controlled and manual cases of the AGDHS according to ambient temperature, flow rate of zone 3 and energy efficiency [180]	45
Figure 2-11 A typical fuzzy-PID controller	53
Figure 2-12 Structure of neural network	58
Figure 2-13 Fuzzy controller using genetic algorithm structure [303]	62
Figure 2-14 The fuzzy membership functions for change in error for T [303]	63
Figure 2-15 The fuzzy membership functions for change in error for Q [303]	63
Figure 2-16 Genetic fuzzy temperature control [303]	63
Figure 3-1 (a) Air-conditioned zone (b) Air-supply channel	74
Figure 3-2 Indoor temperature and humidity model	78
Figure 3-3 A two-input two-output system	80
Figure 3-4 A two-input two-output system with decoupling design	81
Figure 3-5 Equivalent system of two-input two-output system	82
Figure 3-6 Indoor temperature and humidity system	83
Figure 3-7 The indoor temperature and humidity system with decoupling strategy	83
Figure 3-8 Structure of fuzzy-PID controller	87
Figure 3-9 Scheme flow chart of the fuzzy block	88
Figure 3-10 Membership function of system error	91
Figure 3-11 Membership function of system error changing rate	91
Figure 3-12 Membership function of k_p	92
Figure 3-13 Membership function of k_i	92
Figure 3-14 Membership function of k_d	93
Figure 3-15 Flow chart of fuzzy-PID controller	94

Figure 3-16 RBFNN based PID controller	96
Figure 3-17 The RBF neural network	98
Figure 3-18 Flow chart of RBFNN-PID controller	102
Figure 3-19 BPNN based PID control scheme	104
Figure 3-20 BPNN algorithm scheme	105
Figure 3-21 Adjustment of weight from hidden layer to output layer	109
Figure 3-22 Error function of the network hidden layer	110
Figure 3-23 Adjustment of weight from input layer to hidden layer	111
Figure 3-24 Flow chart of BPNN-PID control scheme	113
Figure 4-1 Screen shot of Matlab program	120
Figure 4-2 System output response to step input	121
Figure 4-3 PID output response to step input	122
Figure 4-4 PID parameters auto tuning	122
Figure 4-5 PID parameters varying based on e	123
Figure 4-6 PID parameters varying based on e_c	124
Figure 4-7 System output response to step input	127
Figure 4-8 PID output response to step input	128
Figure 4-9 PID parameters regulating process	128
Figure 4-10 Jacobian value	129
Figure 4-11 PID parameters tuning related to Jacobian value	130
Figure 4-12 System output response to square input	131
Figure 4-13 network output response to square input	132
Figure 4-14 Jacobian value	132
Figure 4-15 PID parameters regulating process	133
Figure 4-16 PID parameters tuning related to Jacobian value	134
Figure 4-17 System output response to step input	137
Figure 4-18 PID output response to step input	138
Figure 4-19 PID parameters auto regulating	139
Figure 4-20 Relation between PID parameters and system error	140
Figure 4-21 PID parameters response to e_c	141
Figure 4-22 PID parameters response to PID output	141
Figure 4-23 PID parameters response to system output	142
Figure 5-1 System schematic graph	146
Figure 5-2 Photos of test rig	147
Figure 5-3 Schematic diagram of environmental chamber and air duct	148
Figure 5-4 Photo of thermocouple	148
Figure 5-5 Photo of humidity sensor	149
Figure 5-6 Photo of CO ₂ sensor	150
Figure 5-7 Photo of the controller [309]	150
Figure 5-8 Structure of control system	151
Figure 5-9 User interface of the controller	153
Figure 5-10 Membership functions of error and k_p	154

Figure 5-11 Membership functions of ec and ki	154
Figure 5-12 Membership function of kd	155
Figure 5-13 Fuzzy rule base	155
Figure 5-14 Test of fuzzy system	156
Figure 5-15 Fuzzy system load VI	157
Figure 5-16 Front panel of fuzzy system load VI	157
Figure 5-17 MIMO fuzzy controller	158
Figure 5-18 Program diagram of fuzzy controller	158
Figure 5-19 Program of sending kp, ki and kd to the PID controller	158
Figure 5-20 Indoor temperature measurement	161
Figure 5-21 Indoor temperature monitored in Oct-2012	161
Figure 5-22 Indoor temperature monitored in Nov-2012	162
Figure 5-23 Indoor temperature monitored in Dec-2012	162
Figure 5-24 Indoor temperature monitored in Jan-2013	164
Figure 5-25 Indoor temperature monitored in Feb-2013	164
Figure 5-26 Indoor temperature monitored in Mar-2013	165
Figure 5-27 Monthly mean indoor and outdoor temperature during the experimental period	165
Figure 5-28 Monthly standard deviation of indoor temperature	166
Figure 5-29 Indoor RH monitored in Oct-2012	169
Figure 5-30 Indoor RH monitored in Nov-2012	171
Figure 5-31 Indoor RH monitored in Dec-2012	171
Figure 5-32 Indoor RH monitored in-Jan 2013	172
Figure 5-33 Indoor RH monitored in Feb-2013	173
Figure 5-34 Indoor RH monitored in Mar-2013	173
Figure 5-35 Monthly mean indoor humidity	174
Figure 5-36 Stand deviation of indoor relative humidity	175
Figure 5-37 Indoor CO ₂ level monitored in Oct-2012	178
Figure 5-38 Indoor CO ₂ level monitored in Nov-2012	178
Figure 5-39 Indoor CO ₂ level monitored in Dec-2012	179
Figure 5-40 Indoor CO ₂ level monitored in Jan-2013	180
Figure 5-41 Indoor CO ₂ level monitored in Feb-2013	181
Figure 5-42 Indoor CO ₂ level monitored in Mar-2013	181
Figure 5-43 Mean indoor CO ₂ level	182
Figure 5-44 Maximum indoor CO ₂ level	183
Figure 6-1 Structure of controller combined PID control and intelligent algorithm	197

NOMENCLATURES

A_w	area of the wall	m^2
C_{ico_2}	the indoor CO ₂ concentration	ppm
C_{ion}	the indoor CO ₂ concentration at the moment when the ventilation system is turned on	ppm
C_{oco_2}	the outdoor CO ₂ concentration	ppm
C_p	heat capacity of air	$J/kg \cdot ^\circ C$
d_w	thickness of the wall	m
e_p	specific potential energy	kJ/kg
E_{co_2}	the average CO ₂ emanation rate of each person in the indoor environment	ppm/s
f	volume flow rate of the supplied air	m^3/s
h_{air}	convection heat transfer coefficients of air	$W/m^2 \cdot ^\circ C$
h_i	indoor humidity of the air-conditioned zone	g/kg
h_o	outdoor humidity	g/kg
H	vapor enthalpy	kJ/kg
I_{cl}	clothing insulation	clo=0.155°C/W
K_b	thermal conductivity of common brick work	$W/m \cdot ^\circ C$
L	mechanical energy	J
M	metabolic rate	W/m ²
p_a	vapour pressure	kPa
Q_{h1}	work rate of heater	W
Q_{h2}	work rate of humidifier	W
t_a	air temperature	°C
t_{mr}	mean radiant temperature	°C
T_i	indoor temperature	°C

T_{icO_2}	time constant of the indoor CO ₂ control system	s
T_{ih}	time constant of indoor humidity transfer function	s
T_{it}	time constant of the transfer function of indoor temperature and humidity change	s
T_o	outdoor temperature	°C
T_{om}	mean outdoor temperature of the previous seven days	°C
U_w	overall heat transfer coefficient	$W/m^2 \cdot °C$
v	relative air velocity	m/s
V_i	volume of the room	m^3
Greek symbols		
λ	the CO ₂ decay constant	s^{-1}
τ	time	s
ρ_a	density of air	kg/m^3

ABBREVIATIONS

AC	Auxiliary cooling
AH	Auxiliary heating
AI	Artificial Intelligence
ANFIS	Adaptive Neuro-Fuzzy Inference System
ANN	Artificial neural network
ANSI	American national standards institute
ASHRAE	American society of heating, refrigerating and air conditioning engineers
ATG	Adaptive temperature Limits guideline
AW	Ventilation window opening angle
BIEMS	Building Intelligent Energy Management Systems
BPNN-PID	Back propagation neural network based PID
CEN	European committee for standardization
CI	Computational Intelligence
CO	Carbon monoxide
CO ₂	Carbon dioxide
COP	Coefficient of performance
DCV	Demand-controlled ventilation
DGI	Daylight Glare Index
DHS	District heating system
DOAS	Dedicated outdoor air system
DOAS	Dedicated outdoor air system
EPBD	European energy performance of buildings directive
FLC	Fuzzy logic control
GA	Genetic algorithm
GDHS	Geothermal district heating system
HVAC	Heating, ventilating and air conditioning
I/O	Input/output
IAE	Integral of the absolute value of the error
IAQ	Indoor air quality
IEQ	Indoor environment quality
ISO	International organization for standardization
KF	Kalman filter
MLP	Multi-layer perception
MVOCs	Microbiological volatile organic compounds
NB	Negative big
NM	Negative medium
NN	Neural network
NS	Negative small
NTU	Number of transfer units

PB	Positive big
PER	Primary energy requirement
PID	Proportional-integral-derivative
PM	Positive medium
PMV	Predicted mean vote
PPD	Predicted percent dissatisfied
ppm	Parts per million
PS	Positive small
RBF	Radial basis function
RBFNN-PID	Radial basis function neural network based PID
RBFNNs	Radial basis function neural networks
RH	Relative humidity
ROS	Reactive oxygen species
SARS	Severe Acute Respiratory Syndromes
SBS	Sick building syndrome
SISO	Single-input single-output
SST	Summer set point temperature
UFP	Concentrated ultrafine particles
USEPA	United States environmental protection agency
VAV	Variable air volume
VOCs	Volatile organic compounds

Chapter 1 Introduction

1.1 Background

In recent years, a growing number of heating, ventilating and air conditioning (HVAC) systems are being installed in buildings as a way of providing thermal comfort and improving indoor air quality (IAQ) for occupants [1]. It is acknowledged that the indoor environment is very important to health and work efficiency for the people who spend most of their time indoors. The indoor environment can be affected by many factors such as temperature, relative humidity, actual occupancy level, ventilation, particle pollutants, biological pollutants and gaseous pollutants [2]. In the HVAC research field, the indoor thermal comfort and indoor air quality are mostly of concern.

Research in thermal comfort is related to the sciences and technologies of physiology, HVAC and control, etc. Several different types of thermal comfort standards have been introduced based on the current knowledge of occupants' thermal comfort. For example, ASHRAE-55 has been developed based on the information collected from different field studies performed in several countries: Canada, USA, UK, Greece, Pakistan, Thailand, Indonesia, Singapore and Australia as shown in Figure 1 [3]. Hence to improve the indoor thermal comfort now and in future an important worldwide subject.

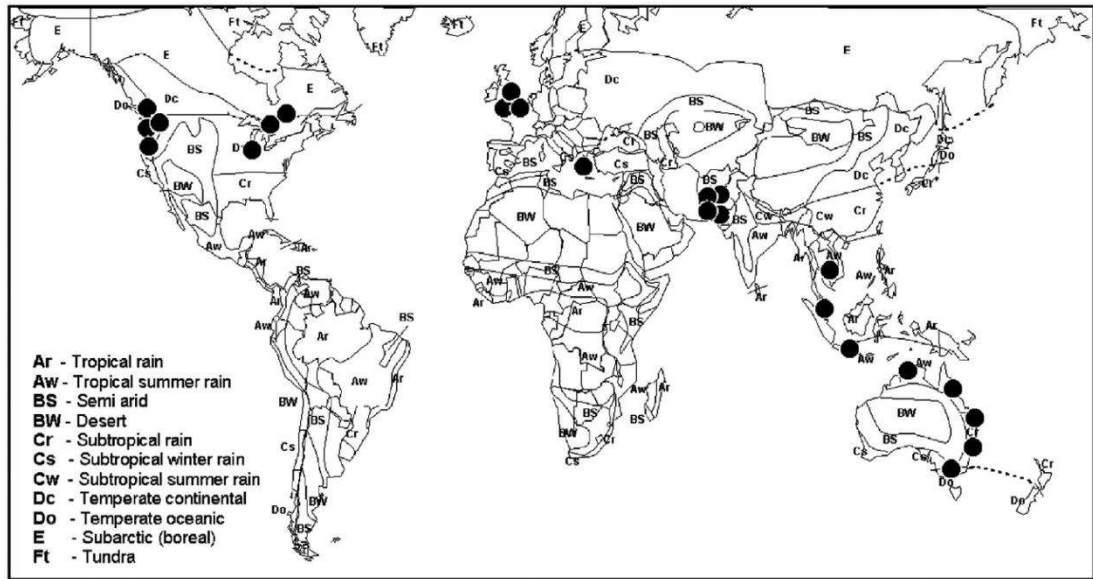

Figure 1-1 The geographic distribution of building studies that formed the basis of the comfort standard of ASHRAE [3]

These standards have been widely applied for the purpose of occupant thermal comfort in different buildings. The regions where buildings located also lead to different standards of thermal comfort as listed in Table 1-1. The equations listed in Table 1-1 are used calculate the comfort temperatures, and T_{om} is the mean outdoor temperature of the previous seven days.

Table 1-1 Thermal comfort standard for individual countries [4]

Country	Thermal comfort standard	
	$T_{om} < 10^{\circ}\text{C}$	$T_{om} > 10^{\circ}\text{C}$
France	$0.049 \cdot T_{om} + 22.85$	$0.206 \cdot T_{om} + 21.42$
Greece	NA	$0.205 \cdot T_{om} + 21.69$
Portugal	$0.381 \cdot T_{om} + 18.12$	$0.381 \cdot T_{om} + 18.12$
Sweden	$0.051 \cdot T_{om} + 22.83$	$0.051 \cdot T_{om} + 22.83$
UK	$0.104 \cdot T_{om} + 22.85$	$0.168 \cdot T_{om} + 21.63$

Hence, it is known that the indoor thermal is a complex subject and must be dealt with for a better indoor environment quality. Indoor air quality is another key factor of indoor environment quality. Over the past decades, exposure to indoor air pollutants is believed to have increased due to a variety of factors, including the

reduction of ventilation rates (for energy saving), the construction of more tightly sealed buildings, and the use of synthetic building materials and furnishings as well as chemically formulated personal care products, pesticides and household cleaners. Poor indoor air quality could result in different kinds of diseases [5]. Researchers started paying attention to this issue and started measuring the relative indoor air pollutants in 1990s [6]. The indoor air pollutants considered including: carbon dioxide (CO₂), carbon monoxide (CO), radon, odour, chemical and microbiological volatile organic compounds (VOCs/MVOCs) can significant impact the indoor air quality. Sometimes symptoms or sensory irritation in eyes may likely be caused if the concentrations of the air pollutants are lower than certain levels. How, if the some of the mentioned air pollutants levels are higher than the acceptable levels, major harm may be caused to human body. The event of Severe Acute Respiratory Syndromes (SARS) in 2003 is one of such examples. The thresholds for some VOCs are listed in Table 1-2 [6]. Hence, the indoor air quality must be well monitored and controlled in an indoor environment for people's health and working efficiency. Moreover, it must be noticed the IAQ is a complex subject and relative researches should be and have been carried out to understand it better.

Table 1-2 Ratio of thresholds for odour and sensory irritation for selected VOCs[6]

VOC	Odour ($\mu\text{g}/\text{m}^3$)	Sensory irritation (mg/m^3)
Formaldehyde	110	0.6-1
Toluene	644	376
Butanol	90	300
Acetic acid	5	25
Limonene	45	445

Studies have helped us better understand of thermal comfort and indoor air quality and the different standards have been developed for specific situations. The solution to maintain the indoor parameters like temperature, humidity and concentration of selected air pollutant at certain levels based on the proper chosen standard is another

issue to be dealt with. Most of these factors can be adjusted through HVAC systems and they are vital to improving indoor environmental quality and air quality. Different types of HVAC systems were developed and used in buildings for improving indoor climate quality. For example, central chilled water system is one popular type of HVAC system developed for improving the thermal comfort of indoor environment [7]. Such HVAC system is mostly applied in modern commercial and office buildings especially in large and high rise buildings. It has been claimed in literature that the indoor climate quality can be significantly enhanced and satisfaction can be obtained from the occupants with the use of HVAC systems [7]. Therefore, researchers including HVAC engineers keep working on this subject and modifying the current systems and developing new HVAC system as required. The increasing use of HVAC to improve indoor environment will inevitably result in considerable energy consumption. Currently, conventional HVAC systems consume approximate half of the total electric energy that is largely depend upon fossil fuel in modern cities [8]. For instance, the mentioned central chilled water system always contributed a large part of the total electricity energy consumption in buildings. As more air conditioning equipment are installed in offices, commercial residential buildings, aiming for providing comfort indoor environment, it could result in a significant increase in greenhouse gases emissions from HVAC applications. Therefore, the demand for environmental comfort is in conflict with the call for reduction of energy consumption and environmental protection. Hence, it is a pressing issue to address the conflict and it is a necessary to find the way out for improving indoor environment with the least energy consumption.

Besides the problem of energy consumption, sometimes the incorrect operation of the HVAC systems may not help to improve indoor environment. For example, it is reported that if the HVAC systems are not operated properly, poor indoor thermal comfort are caused as a result due to over heating or over cooling [4]. Moreover,

such over working of HVAC systems may easily lead to poor indoor air quality as well. Thus, even though HVAC systems have been widely used for the purpose of enhancing indoor occupants comfort, the negative results are obtained occasionally. For this reason, there is the demand of developing rules for HVAC operation [6].

Therefore, in order to optimize the performance of HVAC systems, controller designers for the controlling systems have been working on developing various control strategies for HVAC systems. The control systems for indoor building environments can be mainly classified into two categories according to the approaches employed: the conventional controllers and computational intelligence techniques. The proportional integrate derivative (PID) controller is one of the most popular conventional controller for HVAC systems. Intelligent controller, neural networks have recently become practical as a fast, accurate and flexible tool to HVAC control strategy modeling, simulation and design. With a proper designed controller, the performance of a HVAC system can be significantly improved [7]. Moreover, there are several disadvantages that limit the performance of current control technologies. For example, the on/off control causes the system switching working state too frequently; and neural networks are hard to put into application. Hence, it is worth developing novel control strategies for HVAC system for the purpose of optimizing the indoor environment quality and energy efficiency. In this research, new controllers are developed and their performances as well as their potentials in HVAC systems control are discussed.

1.2 Aim and objectives

Aim of this control strategy is to design control strategies by combining conventional and intelligent control technologies for indoor environment quality control including indoor air temperature, indoor humidity control and indoor air quality control with the computational modeling and experimental investigation and to point the potential direction of improving occupants comfort in built environment. It is difficult to

develop a universal control strategy for both residential and commercial buildings; therefore, this research selects the indoor environments of office areas as its control objects. Moreover, it looks into the development of novel control technologies for better control performance on indoor temperature, humidity and air quality management.

In order to achieve the aim, the following challenges and major works need to be tackled:

(1) The Combination of conventional control and intelligent control

To combine the conventional and intelligent control technology is a research interest area among recent HVAC systems control designers. Because both conventional and intelligent control technologies have their own disadvantages that may limit the control performance. The advantages and disadvantages of current control technologies are discussed in detail in Section 2.2. For example, for conventional control technologies, PID controllers are widely applied to HVAC systems in buildings and relevant areas because they are practical, easy to put into use and good stability. However, PID control has to be designed based on a specific building environment and the mismatch of building model always lead to poor control performance. For intelligent control technologies, fuzzy logic control for instance has better adaptability than PID controllers but the difficulties of implementation. Researches have been carried out to overlap between different categories of controllers for developing control strategies for different purposes. The purpose of such design concept is to use the advantages of each control methods and to avoid the disadvantages of them. In this research, all the novel control strategies for indoor temperature, indoor humidity and air quality are designed based on the principle of combing the conventional and intelligent control technologies and highlighting the merits of both, as well as removing the limitation of their drawbacks.

(2) Design of controller for indoor temperature control

Indoor temperature is one of the key factors that affect the indoor environment quality. Hence the control strategy for indoor air temperature is the first controller designed in this project. The difficulties and challenges in indoor temperature control can be generally summarized as time delay and influence of humidity, which more details are discussed in Section 2.1. Thus, according to such discussion, the designed controller has to have the following requirement: quick response, small overshoot, good adaptability and intelligent algorithm.

(3) Design of controller for indoor humidity control

Indoor humidity known as another factors of indoor thermal comfort and can affect the occupant comfort and people's health and a newly control strategy is designed for this indoor climate parameter. There are difficulties existing in humidity control that is known generally large time delay and more details are discussed in Section 2.1. Hence a control strategy whose algorithm has quick processing speed must be developed for controlling this important signal.

(4) Design of controller for indoor CO₂ control

Besides the thermal comfort, the indoor air quality is also an important factor that affects the indoor environment quality especially the sensation and health of occupants in building. The monitor and control of indoor air quality is a complex mission since there are many types of indoor air pollutants and it is impossible and unnecessary to control all of them. The concentration of indoor CO₂ is used as the control signal of this control strategy. The challenge of indoor CO₂ control includes mismeasurement and disturbances of uncertain parameters. It requires the novel controller must have very good stability and adaptability as well as the intelligent algorithm that is able to quickly response to any situation.

(5) Fuzzy PID control

In order to analyze the potential of improving the indoor climate quality with advanced control technologies, a fuzzy logic based intelligent PID controller is designed for indoor environment quality improvement. The control algorithm is developed and introduced in detail in Section 3.3. Then the computer simulation is used to study its control performance in Section 4.1. Finally, the experimental investigation is carried out to analyze the fuzzy PID controller's performance on indoor climate improvement. Experiments including indoor temperature, indoor humidity and indoor air quality control by using proposed fuzzy PID controller are introduced in Chapter 5.

(6) RBFNN PID control

In order to further analyze the potential of using advanced control technologies to improve indoor environment quality, a RBFNN-PID controller is developed considering the difficulties of indoor humidity control. RBFNN has faster calculating and processing speed compared to other intelligent neural networks. This advantage makes it suitable for indoor humidity control and there is no such research yet. In this project, based on the principle of using overlapped control strategy, the humidity controller is designed based on PID control and radial basis function neural network and discussed in Section 3.4. The control performance is indicated in Section 4.2.

(7) BPNN PID control

A novel IAQ controller using BPNN-PID control technology is developed in this research. The PID controller is used for indoor CO₂ concentration control. The neural network is used for PID parameters tuning and the back-propagation algorithm is used for updating the weights of the neural network. The advantage of this control strategy is disturbances resistance and it is suitable for CO₂ control. The control performance

is verified by simulation using Matlab code discussed in Section 4.3.

1.3 Research Methodology

Aim of this control strategy is to design control strategies by combining conventional and intelligent control technologies for indoor environment quality control including indoor air temperature, indoor humidity control and indoor air quality control with the computational modeling and experimental investigation and to point the potential direction of improving occupants comfort in built environment. Three controllers are to be designed to analyse the potential of newly proposed controllers for indoor environment quality (IEQ) control and the idea of using complex control strategy combined by different control techniques. The work is broken down to several parts as shown Figure 1-2.

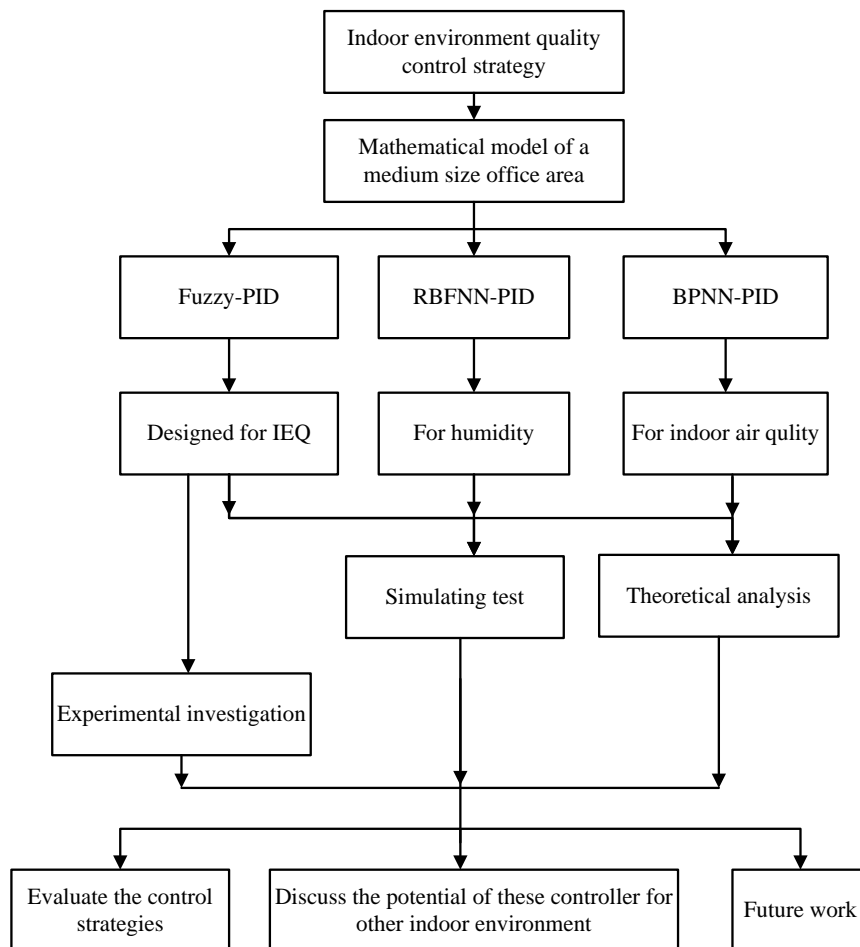

Figure 1-2 Breakdown structure of this research

Following tasks as shown in Table 1-3 are needed to be accomplished as the way to achieve the aim and objectives of this research.

1. Review: the problems of indoor environment quality control and current control methods are needed to be reviewed.
2. Controllers design: this is the main part of this research. Three controllers: fuzzy PID control, RBFNN-PID and BPNN-PID control are designed. The PID controller is used to control the indoor climate because of its merits and the overlapped intelligent control is used to auto tune its parameters. In addition, the selections of intelligent controllers for different control objects are decided based on the challenges and difficulties of each indoor environmental parameter control.
3. Theoretical analysis: after the control rules and algorithms have been developed, the theoretical analysis is necessary to carry out to discuss the control performance. In this way, the advantages and disadvantages of each control can be understood in advance.
4. Simulating tests: simulations are used to conduct the performance of the control strategies. The simulating tests are studied on the platform of Matlab.
5. Simulating results analysis: the results are analysed to understand the developed technologies. If the controllers do not meet the desired requirement they to be modified before applied to real systems.
6. Build the test rig: test rig is designed and built to carry out the experimental tests and more details are discussed in Section 5.1.
7. Experimental tests: experiments of indoor temperature, relative humidity control and CO₂ control are carried out.
8. Experimental results analysis: the data collected in experiments are used to

analyse the control performance and indoor environment quality improvement.

9. Discussion of the proposed controllers

Table 1-3 Task list

No.	Task	Preceding task
1	Review Problem statements Current control methods	N/A
2	Design the controllers Fuzzy-PID controller RBF-PID controller BPNN-PID controller	1
3	Theoretical analysis	2
4	Simulating tests	2
5	Simulating results analysis	4
6	Build the test rig	2
7	Experimental tests carried out	5
8	Experimental results analysis	6
9	Discussion of the proposed controllers Control performance Indoor climate improvement	3,5,8

The listed tasks should be carried out and to be accomplished step by step as shown in Figure 1-3 as the way to achieve the research aim and objectives.

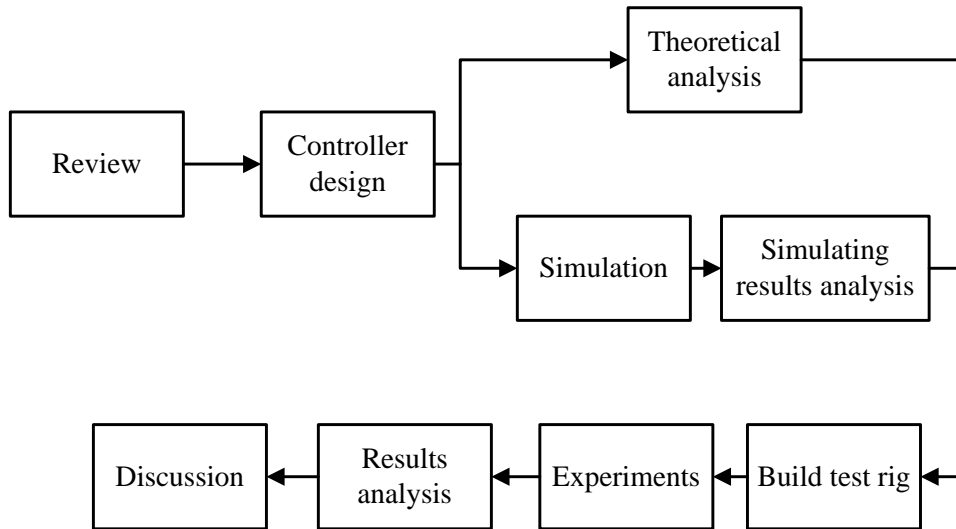

Figure 1-3 Task path

1.4 Outline of thesis

This thesis, comprised of 6 chapters, is summarized as follows:

Chapter 2 Literature review

In this Chapter, the previous studies and researches relevant to heating, ventilating and air-conditioning systems and control technologies of them are reviewed. Firstly, it reviews the main problem statements including the knowledge of thermal comfort including the definition of it; the parameters affect it, importance of it and the current thermal indexes. Secondly, the indoor air quality is introduced in detail including: the important role that IAQ plays in the indoor environment, the factors that influence the indoor air quality, the harm that caused by poor indoor air quality and the possible way to control it. Then the urgent issue of energy efficiency is introduced including the reason that caused this problem, the energy cost in buildings and the way for energy saving. In addition, the HVAC systems that are applied to improve indoor environment quality are introduced and case studies are introduced to show limitation of using HVAC system for the purpose of indoor climate improvement. Finally, the control technologies that have been used for HVAC systems control and

that have the potential to be applied for HVAC systems control in the future are introduced. Moreover, the disadvantages and future perspectives are summarized in order to show a full image of the research in the HVAC systems control field that this research stands at and role in exploring the potential of improving indoor occupants' comfort using novel control strategies.

Chapter 3 Controllers design

This chapter firstly introduces the studied indoor environment of this research, a medium office area and the mathematical model representing the indoor temperature, indoor humidity and indoor CO₂ concentration of this office area. Then developments of the three newly designed controllers are introduced in detail including their structures and the algorithms as well as the process that how the controllers work. These control strategies are designed based on the difficulties and challenges of each indoor climate factor control. At last, the controllers' performance are analysed theoretically and their advantages and potentials in indoor environment control are summarized so that it has pointed the aspects that need to be focused on and further indicated in other evaluation approaches.

Chapter 4 Simulating results

In this Chapter, simulating tests were carried out to evaluate the proposed controllers: fuzzy-PID controller, radial basis function neural network based PID controller and back propagation neural network based PID controller. The simulating tests of the control processes are based on the mathematical models of the indoor climate that are discussed in Chapter 3. The simulations have been taken on the platform of Matlab. Different reference inputs are introduced to simulating process for more accurate results. Then, the simulating results were discussed to analyse the controllers' performances on the indexes including response speed, stability, overshoot and adaptability. At last the potential of the designed controllers for indoor environment

quality control is discussed based on the simulating results.

Chapter 5 Experimental investigation

This chapter introduces the experimental investigations of the newly designed controllers: fuzzy-PID controller for indoor temperature, indoor humidity and indoor CO₂ in the test rig of environment chamber representing a mediums size office. The experimental results are analysed to evaluate the controllers' performances in indoor climate control. Then, the collected data are simply processed to indicate the controllers' performance.

Chapter 6 Discussion, conclusion and future work

This chapter firstly introduces that the indoor environment could be significantly improved by using proper control strategies. Then, the potential of applying the proposed controllers to other types of buildings with minimum change on their structures and algorithms based on the theoretical analysis, simulating and experimental results. In addition, the idea of designing novel control strategy by combining current conventional and intelligent control technologies is discussed. The novel controllers proposed in this research are all developed based on this principle. Moreover, a concept design that includes the three newly designed controllers is introduced. Final insight has been shed onto the conclusion of this current work and suggestions for future work.

Chapter 2 Literature review

2.1 Problem statements

Researches showed that the greatest majority of people spend 80% - 90% of their time inside buildings which leads to the increase of people's living standard and both objective and subjective requests should be satisfied [7]. In existing and future buildings there is an increasing focus on occupant comfort and energy uses. Therefore, the two main problems that building operators pay attention to are the indoor environment quality and energy efficiency. Indoor climate quality can be affected by a variety of factors like buildings type, construction material, occupancy level, selection of air-conditioning facilities ect. and is strongly related to health of human, people' productivity and occupants' sensations [7]. Energy consumption of buildings depends significantly on the criteria used for the indoor environment (temperature, ventilation and lighting) and building design and operation. Recent studies have shown that costs of poor indoor environment for the employer, the building owner and for society, as a whole are often considerably higher than the cost of the energy used in the same building [9]. Hence, to improve the indoor environment quality is the approach for both occupants' and economic benefits.

Studies related to indoor environment quality had been carried out to understand and analyse such issue. Thermal comfort, involving environmental factors of air temperature, humidity, mean radiant temperature and air exchange rate. It is now widely used to help to understand and human health and people's feeling and to design, monitor, control and operate the building performance. Lately, since air-conditioning systems have been widely used as results of the concern of thermal comfort, the problems caused by the poor indoor air quality (IAQ) appear more frequently (e.g., SBS). IAQ, considering the nature of air in an indoor environment is a measure associated with occupant health and comfort. The widely use of air-conditioning system lead to another major problem that is the increase of energy

consumption in buildings. In the last few decades, the research directions in the research area related to manage indoor thermal comfort, indoor air quality and energy efficiency is to balance the indoor environment quality and energy use to optimise the performance of the both factors.

In this section, two of the indoor environment factors, including thermal comfort and indoor air quality are introduced. Then the energy efficiency is discussed.

2.1.1 Thermal comfort

Thermal comfort is defined as ‘that condition of mind which expresses satisfaction with the thermal environment.’[10]. Prediction of the range of temperatures for this comfort condition depends on environmental and personal factors and is complicated. Recent literature [10] has concluded the principles of several adaptive thermal comfort models and standards: the American ASHRAE 55-2010 standard, the European EN15251 standard, and the Dutch ATG guideline. Today, these standards are increasingly used for the purpose of indoor thermal comfort improvement.

Research in thermal comfort integrates several sciences such as physiology, building physics, mechanical engineering and psychology. According to Nicol [11], there are three reasons for understanding the importance of thermal comfort:

- To provide a satisfactory, healthy and comfortable condition for people,
- To manage energy consumption [12,13],
- To suggest and set standards.

Furthermore, Raw and Oseland [14] suggested six objectives for developing knowledge in the field of thermal comfort:

- Control over indoor environment by people

- Improving indoor air quality (discussed comprehensively by Khodakarami and Nasrollahi [15–17])
- Achieving energy savings
- Reducing the harm on the environment by reducing CO₂ production
- Affecting the work efficiency of the building occupants (discussed by Leyten, Kurvers [18]),
- Reasonable recommendation for improving or changing standards.

The knowledge of human thermal comfort is developed by engineers and physiologists. Afterwards, different indices relating temperature to comfort were developed by engineers and physiologists, and now, different thermal comfort standards were used in different types of buildings.

There are many factors related to occupants' subjective comfort in an indoor climate: temperature, humidity and air circulation; smell and respiration; touch and touching; acoustic factors; sight and colours effect; building vibrations; special factors (solar-gain, ionization); safety factors; economic factors; unpredictable risks. The common influence of these factors cannot be analysed due to current technical limitations, and it is a complex process to simulate and analyse the adaptation of the human body to a certain environment since one reacting to the common action depends more parameters.

Although thermal comfort is a complex concept it is suggested to study it based on the data of environment factors and occupants factors. Environmental factors include air temperature, humidity, mean radiant temperature and air exchange rate. It is believed that occupant factors refer to lifestyle, economic status and adaptive behaviour. Therefore, , the requirements for the thermal comfort in the context of building related built environment should be adjusted based on not only the type of

building but also the age, health status and activities of occupants. For example, an acceptable temperature range for desk workers might be too high for those doing physical work. Another example is given that gyms or factories can be kept at a lower temperature than theatres, offices or commercial buildings. Therefore indices related to thermal comfort are needed to predict and decide the acceptable indoor thermal environment for occupants.

In general, heating, ventilating and air-conditioning systems must be designed based on nationally specified criteria, however, in case of no national regulations are given; international standards should be used for thermal comfort in informative annexes. There are several recommended criteria given for general thermal comfort and they can be concluded as PMV (predicted mean vote) – PPD (predicted percent dissatisfied) model or operative temperature and for local thermal comfort parameters like vertical temperature differences, radiant temperature asymmetry, draft and surface temperatures. Operative temperature is defined as a uniform temperature of a radiantly black enclosure in which an occupant would exchange the same amount of heat by radiation plus convection as in the actual non-uniform environment. Such requirements can be found in existing standard and guidelines.

An index called the predicted mean vote (PMV) that has been widely used to predict acceptable thermal environment for a large group of people was designed [19]. Briefly, four environment variables are taken into account in the PMV function and this is expressed as follows:

$$PMV=f(t_a, t_{mr}, v, p_a, M, I_{cl})$$

where air temperature (t_a), mean radiant temperature (t_{mr}), relative air velocity (v) and air vapour pressure (p_a), activity level (M) and the clothing insulation (I_{cl}).

PMV represents the mean thermal sensation vote on a standard scale for group of building occupants for any given combination of the four environment variables,

prevailing activity level and clothing [19].

Moreover, Fanger introduced six parameters that have effects of thermal comfort as follows [19]:

- Metabolism refers to all chemical reactions that occur in living organisms. It is also related to the amount of activity. The unit of activity is Watt (W).
- The amount of clothing resistance also affects thermal comfort. This parameter is expressed as clo, and it ranges from 0 (for a nude body) to 3 or 4 (for a heavy clothing suitable for polar regions). In this regard, $1 \text{ clo} = 0.155 \text{ } ^\circ\text{C/W}$.
- An ideal relative humidity between 30% and 70%.
- Air velocity has a thermal effect since heat loss can be increased by convection. Moreover, draught can be caused by air movement in a cold thermal zone. The amount of air fluctuations is also important. The unit is normally m/s.
- The air temperature representing the temperature of the air surrounding a human body might be one of the most important parameters (in Celsius or Fahrenheit).
- The other source of heat perception is radiation. Therefore, mean radiant temperature has a great influence for a human body (i.e. how it loses or gains heat from and to the environment).

Table 2-1 Recommended operative temperatures for occupants for sedentary activity based on ISO 7730–1984 [19].

Season	Clothing insulation (clo)	Activity level (met)	Optimum operative temp. ($^\circ\text{C}$)	Operative temp. range ($^\circ\text{C}$)
Winter	1.0	1.2	22	20-24
Summer	0.5	1.2	24.5	23-26

Table 2-2 Recommended operative temperatures for occupants based on ASHRAE 55-1992 [19].

Season	Clothing insulation (clo)	Activity level (met)	Optimum operative temp. (°C)	Operative temp. range(°C)
Winter	0.9	1.2	22	20-23.5
Summer	0.5	1.2	24.5	23-26

Later on, ISO 7730-1984 and ASHRAE 55-1992 were introduced based on Fanger's equations. Examples of temperature bandwidths that resulted from climate chamber studies [19] were presented in Table 2-1 and Table 2-2. Climate chamber studies also known as steady-state studies aim to determine steady-state thermal comfort models. The research is conducted in an environmental test chamber that can vary different climatic parameters.

Field studies showed evidence to prove that PMV model works pretty well in air-conditioned premises, however, this most popular thermal index is not suitable for naturally ventilated buildings [19, 20]. Humphreys [21] argued that thermal comfort standard like the ISO 7730 based on PMV model was not entirely suitable for general applications. Unnecessary cooling in warmer climates and unnecessary heating in cooler regions leading to huge amount of energy cost might be caused by misuse of ISO-PMV, and if such standards are applied in developing countries there would be adverse economic and environmental penalty. Humphreys and Nicol evaluated the validity of comfort theories through several field studies and research data showed that the range of comfort temperature in naturally ventilated building is much wider than what PMV_PPD models predict (especially in summer) [11, 22-24].

Table 2-3 summaries some of the recent studies [25-31]. In general, the actual acceptable temperature ranges were suggested, by these studies, to be broader than the comfort temperature range stipulated in either the ASHRAE standard [29] or local standard [32]. Therefore, consideration should also be given to other factors

such as individual control/differences, climate context and carbon footprint, rather than simply the conventional thermal comfort and thermal neutrality [25, 31, 33]. For example, 24°C -26°C is the desired range of temperatures indicated in guidance for internal temperatures for various types of buildings [34]. But most of participants would like to set the temperature around 25.6°C in summer and 20°C in winter, which are regarded as the standard temperature in air conditioning systems [35].

Table 2-3 A summary of works on thermal comfort standards [21]

Region (year)	Ref	Building	Key remarks
Global (2002)	[25]	General	5 key issues: (i) Satisfaction and inter-individual differences, (ii) climate context, (iii) role of countries(especially personal/individual), (iv) beyond thermal neutrality, and (v) beyond thermal comfort.
Netherlands (2006)	[26]	Office	The 90% acceptability is allowed to exceed in 10% of the occupancy time (i.e. at least 90% satisfied for at least 90% of the time), and indoor temperature limits are given as a function of mean outdoor temperature.
Europe (2010)	[27]	Office	The differences between European Standard EN 15251 and ASHRAE 55 were discussed. Suggested allowance in EN 15251 for air speed using fans can be applied to the equation for naturally ventilated buildings.
Global (2010)	[28]	General	New thermal comfort standards that allow occupants to choose and control their preferred temperature will be used. In future, buildings will be increasingly classified based on their energy use and carbon footprint.
China (2010)	[29]	University Classroom	The Chongqing adaptive comfort range is broader than that of the ASHRAE Standard 55-2004.
Korea (2012)	[30]	Office	Occupants would feel comfortable even at 28°C depending on the previous running mean outdoor temperature, 2°C higher than the 26°C stipulated in the Korean Standard.

Indoor humidity is also a key factor that affects indoor thermal comfort besides temperature. This involves manipulating indoor temperature and humidity levels. The upper limits for relative humidity that typically are in the range of 60%-80% is a safe level for indoor thermal and moisture conditions, and is also generally known that they can be set too high if out of concern for the health effects [36]. The recommended value of upper indoor relative humidity is 70% according to study [37].

Since indoor thermal comfort is a major statement of the indoor environment quality, indoor temperature and humidity should be well monitored and controlled for occupants' comforts and energy efficiency. Hence, HVAC technologies have been developed and proper control technologies are required to operate HVAC systems for this purpose.

2.1.2 Indoor air quality

As air conditioning systems have been widely used in buildings for better thermal comfort, the problems caused by the poor indoor air quality (IAQ) appear more frequently (e.g., SBS). IAQ is not a concept can be easily defined, since the nature of air in an indoor environment is a measure associated with various parameters like occupant health and comfort. Moreover, IAQ was ranked as one of the top five environmental risks to occupant health by the United States Environmental Protection Agency (USEPA) based on Field studies on comparative risk [38]. Over the past decades, exposure to indoor air pollutants is believed to have increased due to a variety of factors, including the reduction of ventilation rates (for energy saving), the construction of more tightly sealed buildings, and the use of synthetic building materials and furnishings as well as chemically formulated personal care products, pesticides and household cleaners.

There are many types of indoor pollutants such as CO₂, CO, volatile organic

compounds (VOCs), radon, NO₂, indoor particles. The poor indoor air quality may cause several types of symptoms and tiredness, dry irritated or itchy eyes and headache are the top three symptoms according to relevant studies [39-41] as shown in Table 2-4.

Another major problem that caused by poor indoor air quality is the odour issue that will lead to several impact on human body such as productivity reduction, mental distraction, etc as presented in Table 2-5.

Hence, it is important to monitor and control indoor air quality in a built environment for people's health, comfort and improving productivity, et al. Based on Peder's review, approaches to improve indoor air quality in office can be as follows [6]:

- Sampling of labile species, e.g. secondary ozonides.
- High volume sampling: reactive oxygen species (ROS), e.g. OH radical, other organic radicals, and antioxidant depletion.
- UFP (on-line): number and size-distribution. Transition metal and elemental carbon analysis.
- Black carbon particles: a potential proxy for combustion particles to evaluate health risks.
- Personal exposure measurements, e.g. nitrogen dioxide as proxy for exposure to combustion/traffic pollutants.

Table 2-4 Frequent symptoms prevalence (%) from major studies in offices [6]

*N - total number of respondents/R - response rate in %

Study	[39]	[40]	[41]
Country	9 European countries	USA	London, UK
N/R*	6537/19	-/93	4052/-
Recall period (days)	1	30	14
Symptoms	Dry skin (32)	Tired or strained eyes (33)	Headache (44)
	Lethargy (31)	Dry, itching, irritated eyes (30)	Cough (36)
	Stuffy nose (31)	Unusual tiredness, fatigue or drowsiness (27)	Dry, itchy tired eyes (33)
	Dry eyes (26)	Headache (25)	Blocked, runny nose (27)
	Headache (19)	Tension, irritability, or nervousness (23)	Tired for no reason (25)
	Flu-like symptoms (14)	Pain or stiffness in back, neck shoulder (22)	Rashes, itches (20)
	Chest tightness (10)	Stuffy or runny nose (22)	Cold, flu (19)
	Runny nose (11)	Sneezing (18)	Dry throat (18)
	Watering eyes (7)	Sore or dry throat (16)	Sore throat (17)

Table 2-5 Reported impact by odour [6]

Effect	References
Annoyance	[42]
Behaviour	[43]
Breathing pattern	[44], [45] and [46]
Exacerbation of asthma	[47]
Perceived risk for unknown exposure (worry)	[48] and [49]
Mood	[50], [51], [52], [53] and [54]
Risk of perceived “bad” health (Multiple chemical sensitivity)	[55], [56] and [57] [58]
Risk of subjectively perceived sensory irritation	[47]
Risk of mental distraction – altered performance	[59], [60], [61], [62], [63], [64] and [65]

Moreover, in a report presented by Ioan, a testing model of indoor air quality in buildings was developed based on the European Standard CEN 1752 to determine the outside airflow rate and to verify the indoor air quality in rooms [66]. Results showed that the climate in rooms affects the comfort and the health of the occupants at the same time. Moreover, it is advised that the engineers for designing and operating of HVAC systems should preserve the comfort parameters at the optimal values for better control and operating performance. In order to operate and control HVAC system for the purpose of improvement of indoor air quality, researches on control technologies should be carried out.

Since there are many types of indoor air pollutants it is a complicated matter to monitor all of them [67-69]. As investigating all types of indoor air pollutants for general air quality monitoring and control is a complicated matter [70, 71], it was suggested that the measurement and analysis of indoor carbon dioxide (CO₂)

concentration could be useful for understanding IAQ and ventilation effectiveness [72-74]. Although a CO₂ level up to 10,000 ppm is acceptable to healthy people without serious health effect, the CO₂ level should be kept below 1,000 ppm or 650 ppm above the ambient level for the reason of preventing any accumulation of associated human body odour [75, 76]. Table 2-6 presents the harm caused by high CO₂ concentration on human body.

Table 2-6 harm of CO₂ on human body [7]

CO ₂ concentration		Effect
[%]	[ppm]	
3	30,000	Deep breathing
4	40,000	Headache, pulse, dizziness
5	50,000	After 0.5-1 h many cause death
8-10	80,000-100,000	Sudden death

The IAQ standard defined by ANSI/ASHRAE Standard 62-1929 states: 'for comfort, indoor air quality may be said to be acceptable if not more than 50% of the occupants can detect any odour and not more than 20% feel discomfort, and not more than 10% suffer from mucosal irritation, and not more than 5% experience annoyance, for less than 2% of the time' [77]. Being able to influence most of these factors, proper control strategies are needed to operate the building HVAC systems in order for optimizing occupant comfort and energy saving in built environment.

2.1.3 Energy efficiency

The introduction of the use of mechanical means for providing desired comfortable temperature for building users is considered as one of the unfortunate phenomenon of modern global development since. This trend has led to huge energy consumption in the building stock, and nowadays, around one third of fossil fuel is consumed in buildings [78].

There have been marked increase in energy use in developing countries, and it is envisaged that such trend will continue in the near future. For instance, Chinese total primary energy requirement (PER) increased from about 570 to over 3200 Mtce (million tonnes of coal equivalent), an average annual growth of 5.6% during 1978-2010. Although its energy use and carbon emissions per capita are low, China overtook the US and became the largest energy consuming and CO₂ emissions nation in 2009 [79-85]. Chai and Zhang [86] estimated that Chinese PER would increase to 6200 Mtce in 2050 according to the analysis of technology and policy options for the transition to sustainable energy system in China. Moreover, the consumption of fossil fuels would account for more than 70% of total energy cost and the corresponding emissions could reach 10 GtCO₂e (10×10^9 tonnes of CO₂ equivalent). It has been estimated that, energy consumption in emerging economies in Southeast Asia, Middle East, South America and Africa will exceed that in the developed countries in North America, Western Europe, Japan, Australia and New Zealand by 2020 [87].

In many developed countries, the building sector is one of the largest energy consuming sectors, more than both the industry and transportation, accounting for a larger proportion of the total energy consumption. For example, in 2004 40%, 39% and 37% of the total PER in USA, the UK and the European Union was consumed in building sector [88]. In China, building stocks accounted for about 24.1% in 1996 of total national energy use, rising to 27.5% in 2001, and was estimated to increase to about 35% in 2020 [89, 90]. It was reported about 40% of the total PER consumed in buildings that also contribute to more than 30% of the CO₂ emissions [91]. A number of studies conducted worldwide to improve building energy efficiency were started as results of such concern. They can be summarized as follows: sensitivity and optimisation [92-97], on the designs and construction of building envelopes (e.g. thermal insulation and reflective coatings [98], and life-cycle analysis [99, 100]); the control of heating, ventilation and air conditioning (HVAC) installations and lighting

systems [101-104] and technical and economic analysis of energy-efficient measures for the renovation of existing buildings [105-109]. Literatures reported that the major factor why the proportion of energy use in buildings was significantly increased was due to the spread of the HVAC installations in response to the growing demand for better thermal comfort within the built environment. In general, accounting for about half of the total energy consumption in buildings especially non-domestic buildings, HVAC systems are the largest energy end-use in developed countries [110-117]. Energy consumption in both residential and commercial buildings is dominated by space heating, cooling, and air conditioning (HVAC) and lighting as shown in Figure 2-1 [118, 119]. A recent literature survey of indoor environmental conditions has found that thermal comfort is ranked by building occupants to be of greater importance compared with visual and acoustic comfort and indoor air quality [118]. The designs of the building envelopes especially the windows and/or glazing systems are affected by this result [119-122]. Therefore, to have a good understanding of the past and recent development in thermal comfort, indoor air quality is important to manage the energy use in buildings.

Hence, studies have been carried out to contribute to a better understanding of how thermal comfort is related to and affects the broader energy and environmental issues involving social-economic, fuel mix and climate change. Based on the analysis of the energy use of air-conditioning systems in buildings, approaches were introduced for reducing the energy consumption. Generally, the energy efficiency in building includes two aspects: improving the air-conditioning technologies and control techniques. Opportunities for reducing high HVAC-related energy consumption includes use of natural ventilation, minimizing energy wastes in conventional systems by upgrading equipments or downsizing the scale of the equipments, and integrating efficient technologies such as adequate control strategy for potential energy saving. Recently, advanced building technologies and control methods

designed to trim down the energy consumption for an acceptable indoor environment are constantly being development for low energy house.

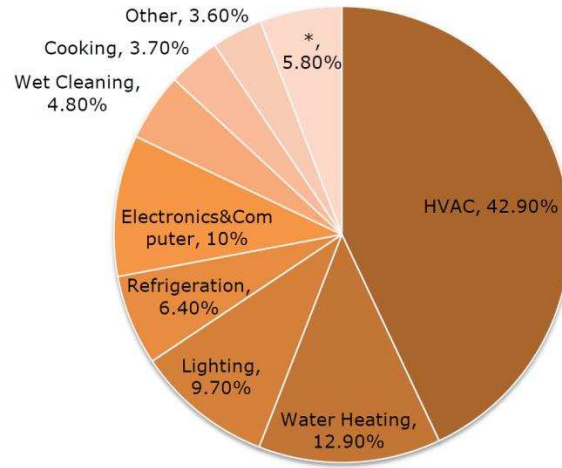

[a]

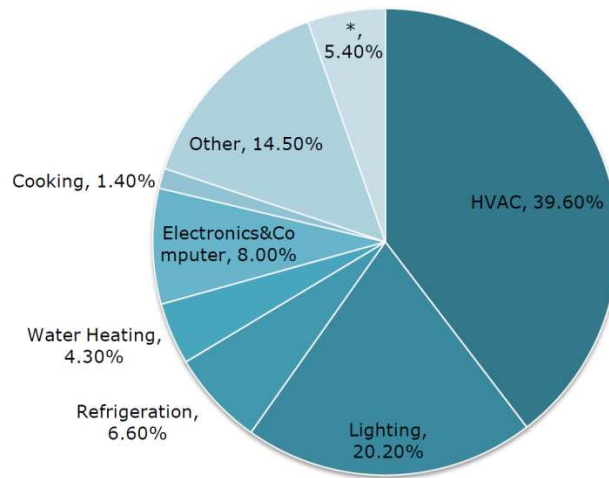

[b]

Figure 2-1 (a) Residential buildings total energy end use (2010). (b) Commercial sector building energy end use (2010) [118, 119]

To include the thermal comfort indices to manage the energy consumption is one widely using control method. Data from extensive and rigorous experiments conducted in climate chambers was used to developed heat balance models and measured/surveyed data from field studies are used to develop adaptive models [123-126]. The advantage of climate chambers test is having consistent and reproducible results, and which of field studies is realism of the day-to-day working or living environments.

Based on current thermal indices, it is known that a wider range of indoor thermal environment can be employed in situations/locations where air conditioning is unavoidable and such operation would lead to less cooling requirements and hence less electricity consumption for the air conditioning systems [127]. Therefore, the method to set a higher summer set point temperature (SST) or implementing a wider/varying range of indoor design temperature for different time of the day and different outdoor conditions was developed. There are two major types of control techniques been proposed to achieve this goal based on such conditions. Diverse thermostat strategies such as changing the setback period, set point temperature and setback temperature are involved in first type [128]. The second type deals with the dynamic control of the set point temperature based on adaptive comfort models [129, 130].

Table 2-7 Summary of energy savings in cooled buildings [20]

City (climate) (year)	Ref	Building	Measure	Energy savings
Hong Kong SAR (subtropical) (1992)	[131]	Office	Raise SST from 21.5 °C to 25.5 °C (SST = summer set point temperature).	Cooling energy reduced by 29%.
Montreal (humid continental) (1992)	[132]	Office	Raise SST from 24.6 °C to 25.2 °C (during 09:00-15:00) and up to 27 °C (during 15:00-18:00).	Chilled water consumption reduced by 34-40% and energy budget for HVAC by 11%.
Singapore (tropical) (1995)	[133]	Office	Raise SST from 23 °C to 26 °C.	Cooling energy reduced by 13%.
Islamabad (humid subtropical) and Karachi (arid) (1996)	[134]	Office	Change the 26 °C SST to a variable indoor design temperature ($T_c = 17 + 0.38T_o$; $T_c = \text{comfort temperature}$,	Potential energy savings of 20-25%.
Hong Kong SAR (subtropical) (2003)	[135]	Office	Change SST from 24 °C (average) to adaptive comfort temperature ($T_c = 18.303 + 0.158T_o$).	Energy consumption by cooling coil reduced by 7%.
Riyadh (hot desert) (2008)	[136]	No specific building type	Change yearly-fixed Thermostat setting (21-24.1 °C) to optimised monthly fixed settings (20.1-26.2 °C).	Energy cost reduced by 26.8-33.6%.
Melbourne (oceanic), Sydney (temperate) and Brisbane (humid subtropical) (2011)	[137]	Office	Static (raise SST 1 °C higher) and dynamic (adjust SST in direct response to variations in ambient conditions).	HVAC electricity consumption reduced by 6% (static) and 6.3% (dynamic).

A summary of some of the case studies involving adaptive comfort models and/or raising the SST is listed in Table 2-7 [131-137]. The results of the listed studies showed that substantial energy savings could be achieved for office and residential buildings, 13% reduction cooling energy cost in hot humidity climate in Singapore

[133] from to 29% reduction in cooling energy consumption in office buildings in Hong Kong by raising 4 °C in the SST [131]. The results also showed that such control strategy is suitable for different types of outdoor environment: from 11% reduction of HVAC energy consumption in humid area in Montreal [132] to 6% reduction of HVAC electricity consumption in oceanic climate area in Melbourne [137]. This could have significant energy policy implications as it helps alleviate and/or delay the need for new power plants to meet the expected increase in power demand due to economic and population growth.

It can be seen that the energy consumption of air-conditioning equipment can be significantly reduced by using proper control strategy. This means that with the implementation of well designed control strategy, the indoor climate quality including acceptable indoor thermal comfort and healthy indoor air quality can be maintained with no extra energy consumed. Hence, in order to improve the performance on energy management further researches should be carried out to develop more advanced control technology.

2.2 Control technologies for HVAC systems

Although the indoor environment comfort issues have been dealt with widely in scientific literatures [138-144], there is now a more and more rising attention among designers of heating, ventilating and air conditioning (HVAC) systems, particularly due to the enactment of the European Energy Performance of Buildings Directive (EPBD) [143]. This directive aims to promote directly the energy performances of the buildings, reduce the conventional fuels consumption and decrease greenhouse gas emissions to the atmosphere. Moreover, it also indirectly gives emphasis to measures and actions devoted to the increasing of the indoor performances [145, 146]. It is well known that the demand for energy management caused by the widely use of HVAC systems in buildings keeps increasing. Researchers started to look for appropriate ways to solve such problems and some researches have proved the

development of control methodologies that could improve energy efficiency of building-HVAC systems while maintaining acceptable indoor climate quality [147-150]. Nevertheless, the simplest conventional control strategy for indoor comfort, proposed up to now, are ON-OFF and the most widely used conventional control technology is proportional, integrative and derivate (PID) methods. In recent decades intelligent control technologies were also developed to operate the HVAC systems for purpose of optimize the indoor comfort and energy efficiency and literatures have shown that some HVAC systems' performances have been significantly improved by proper designed control strategies. Therefore, it follows the requirement of control technique development that is able to reduce energy consumption in buildings while, simultaneously, comfortable and health indoor climate is maintained within acceptable levels. In this section, it firstly describes how well designed control strategies improve the HVAC systems' performance with examples. Then, current control technologies developed for HVAC systems including both conventional and intelligent control methods are introduced briefly. Finally, the merits and drawbacks of current control technologies are summarised and future perspectives are concluded.

2.2.1 Performance improvement of HVAC systems with proper controllers

(1) The control strategy designed for district heating system

District heating system (DHS) is designed to provide heat for inhabitants of large cities., There are many opportunities for utilizing the district heating system in individual low-power boiler-rooms since the capability of thermal plant in the system is rapidly increasing [151, 152]. The advantages for district heating system can be concluded as the increased energy and performance efficiencies through implementing advanced equipment and maintaining them professionally, reduced life cycle costs, augmented control over environmental impacts [153, 154]. In addition,

district heating system reduces the emission of combustion products into atmosphere because of its high efficiencies. Many European countries such as Denmark, Russia, and Finland are deploying [155]. There are potentials that the energy efficiency of DHS can be further improved although it already has excellent performance on energy efficiency. In addition, the performance of DHS on temperature operation can be also well enhanced.

Several reports have introduced the mathematical modelling of the heating district [156, 157], and the researches of the modelling of thermal plants have been progressed by many researchers [158, 159]. Choi [160] developed a mathematical model for the real thermal plant in the district heating system for the purpose of predicting and operating the heat supply and controlling the outlet temperature of the plant. In their control modelling, the basis of the thermal plant operating in unsteady state is predicted by considering the thermal energy balance equation as follows [160]:

$$\dot{m}(e_p + e_c + C_p T) + \frac{\partial}{\partial \tau} \int_V \rho e dV = \frac{dQ}{d\tau} - \frac{dL}{d\tau} \quad (2-1)$$

where C_p is specific heat (kJ/g °C), e_p is specific potential energy (kJ/kg), e_c is specific kinetic energy (kJ/kg), Q is thermal energy (kJ), L is mechanical energy (kJ), V volume (m³), \dot{m} is mass flow rate (kg/s), τ is time (s) and ρ is fluid density (kg/m³), e is the total specific energy (kJ).

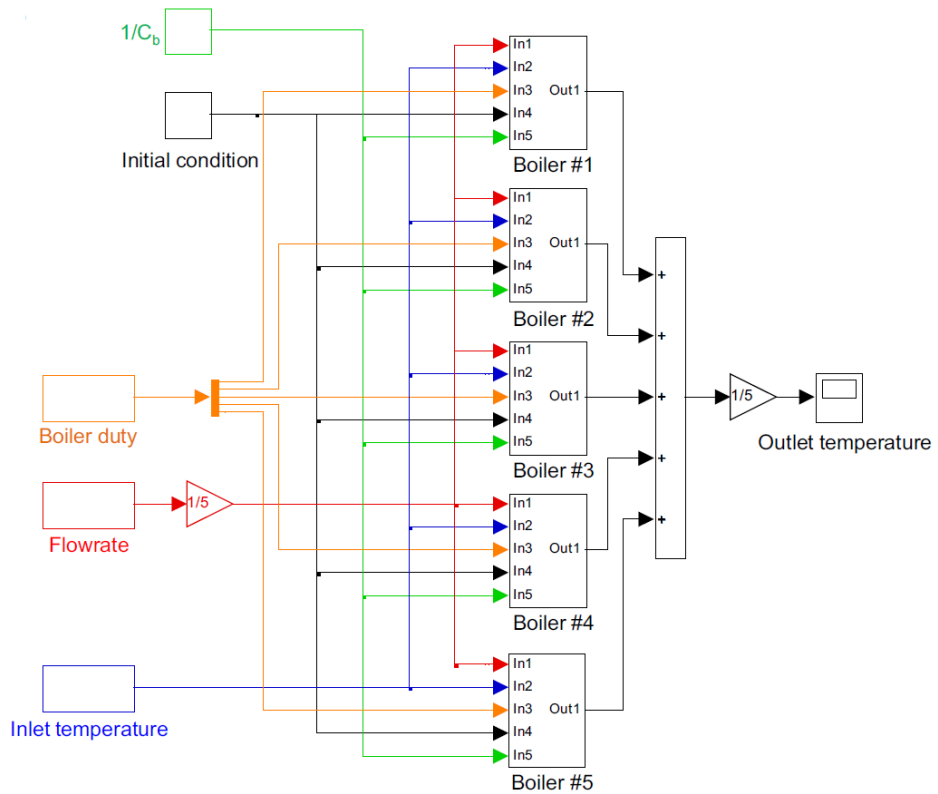

Figure 2-2 Simulink representations for the controlled thermal plant [160]

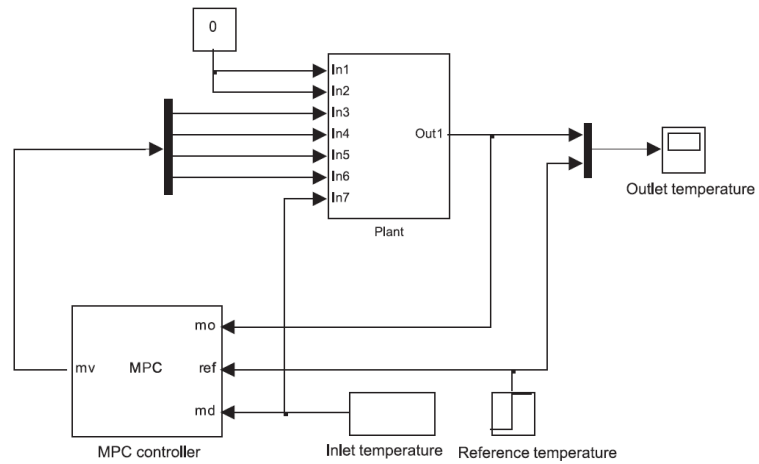

Figure 2-3 Simulink representation for a model predictive control structure [160]

Figure 2-2 shows the controlled direct heating system using Simulink. The sub-block Out 1 – Out 5 represent the boilers since the thermal plant consists of five boilers. The inputs are flow rate, inlet temperature and heat duties for each boiler and the

output is outlet temperature. Figure 2-3 shows the block diagram of the controlled system, where “Plant” is the thermal plant in Figure 2-2. Current value of outlet temperature is sent to the control block “MPC controller” where the model is used to predict the effect of the manipulated variables. The set-point is specified as 117°C in this study, and sampling time, prediction and control horizons are set to be 1 h, respectively.

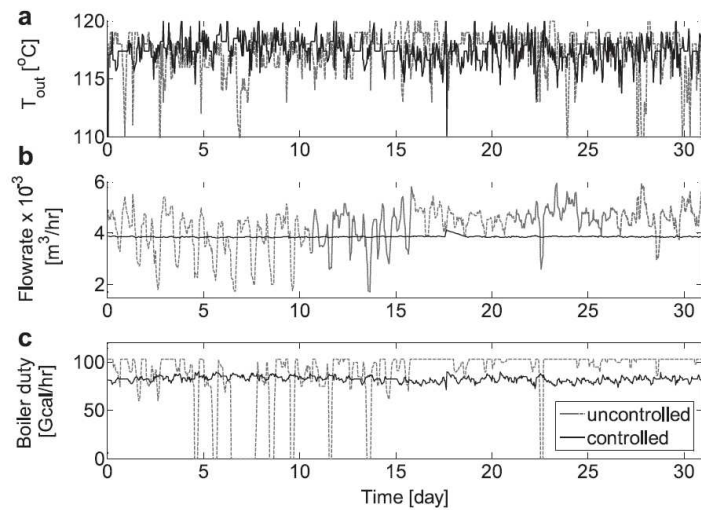

Figure 2-4 Comparison between controlled and uncontrolled cases; (a) outlet temperature, (b) flow rate, and (c) boiler duty [160]

Figure 2-4 shows the comparison of controlled operation to the uncontrolled operation. The results of the outlet temperature for the controlled case (solid line) is maintained around the desired value, 117°C, as shown in Figure 2-4 (a), while the uncontrolled operation (dashed line) varies in a relatively big range of value and deviates from the set-point, 117°C. The advantages of the proposed control strategy are clearly demonstrated in the profile of manipulated variables.

In addition, the total energy cost of the boilers for the controlled case was about 184,000 Gcal for a month, while the uncontrolled case was about 204,000 Gcal as presented in Figure 2-5. This corresponds to the reduction of energy utilization by 9.8% for a month, which is huge savings considering the scale of the entire district

heating system as well as the duration of operation.

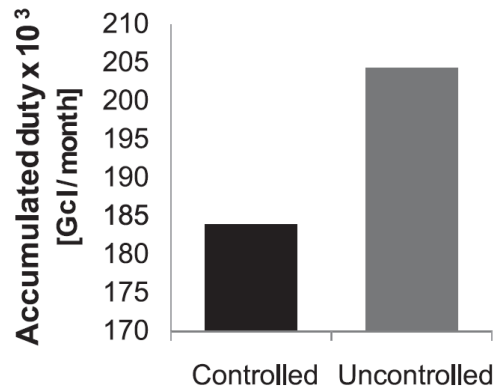

Figure 2-5 Accumulated boiler duty for controlled and uncontrolled cases [160]

The simulating results clearly showed that the proposed controller successfully regulated the outlet temperature of the boiler, and significantly reduced the total amount of heating energy consumption due to the constraints on inputs considered in the control algorithm.

(2) Dedicated outdoor air system (DOAS) control strategy

In the recent study, a dedicated outdoor air system (DOAS) control strategy was proposed. The control system for cooling process, air dehumidification and the desiccant solution regeneration process in the DOAS is shown in Figure 2-6. In this study, control strategies for the supply air dehumidification and cooling process as well as the desiccant solution regeneration process in the DOAS are developed. This control system contains three control loops [161]: the process air loop, desiccant solution loop and regeneration air loop.

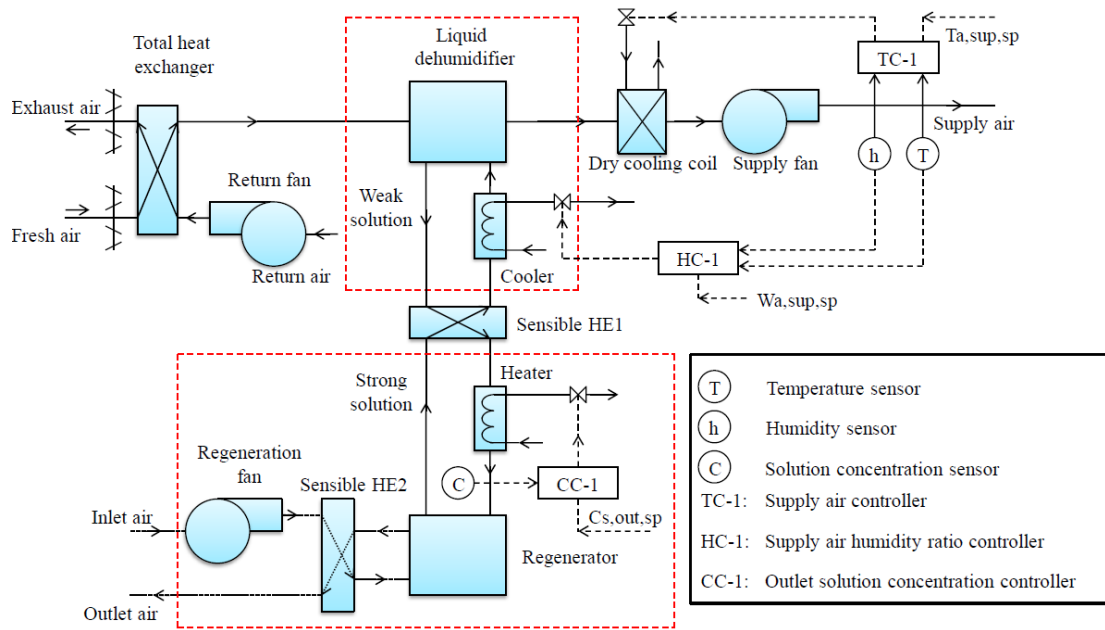

Figure 2-6 Schematic of the liquid desiccant-based DOAS and its control system[161]

The mathematical modelling and simulation of this control strategy is built up on the platform of TRNSYS.

- Membrane-based total heat exchanger: the effectiveness-number of heat transfer unit (ϵ -NTU) model is utilised to model the membrane-based total heat exchanger.
- Dehumidifier and regenerator: the analytical solution applied to model the dehumidifier and regenerator.
- Dry cooling coil: to represent the dynamics of a cooling coil.

In the simulator process, some other components are obtained from TRNSYS.

The performance of the control strategy on several important system parameters are studied by simulation tests. In the simulation process, the whole system performance is evaluated at two conditions: with membrane-based energy recovery (With mem-ER) and without membrane-based energy recovery (Without mem-ER).

The coefficient of performance (COP) is utilised as the rule to evaluate the control performance of the proposed system and is calculated by the following equation:

$$\text{COP} = \frac{Q_c}{Q_T + \frac{W}{0.3}} \quad (2-2)$$

Where Q_c is the cooling production of the system; Q_T is the thermal energy consumption of the system; and W is the total electric power consumption. The equivalent coefficient of electric power and thermal energy is taken as 0.3 [161].

The control system performances on supply air flow rate and ambient air temperature at two different conditions are compared and illustrated in Figure 2-7. As shown in the figures, different system parameters on system COP improvements are in the range of 20%-35%.

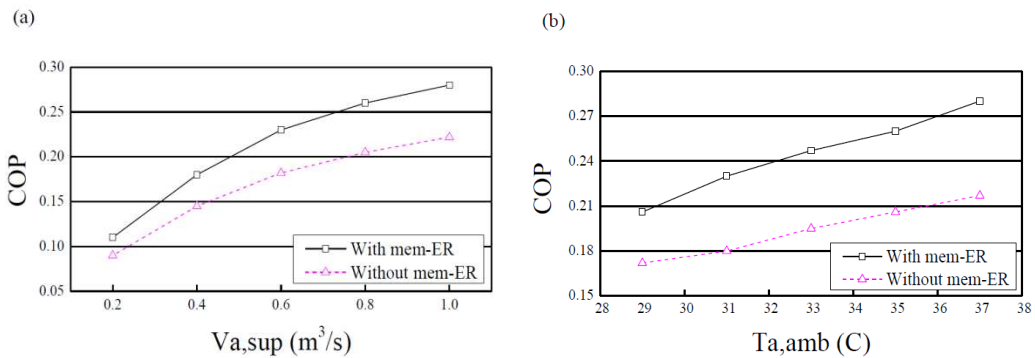

Figure 2-7 (a) Effect of the supply air flow rate on system COP. (b) Effect of ambient air temperature on system COP [161]

The proposed system is a new one and the results have showed that the control system improves occupant's comfort but energy saving performance is not good enough [162, 163]. Al-Rabghi and Aleyurt proposed a control algorithm with a frequently updated daily, weekly and monthly specific occupation schedules and this control strategy has achieved energy saving of 10%-20% [164]. However, there is one problem: when the air-conditioned zone is reoccupied occasionally before or after the scheduled HVAC turn on time, the occupants will be in an unhealthy

environment. Chao and Hu proposed a ventilation control strategy which has the function of determining the occupancy level of the air-conditioned zone [165]. By applying this control strategy, the HVAC system works in different modes in different situations. However, this control strategy has one limitation in practice: the pre-measurement is necessary [165] to obtain the correlations for different applications before the use of this control strategy. Therefore, more researches on control algorithm for HVAC systems should be carried out.

2.2.2 Control objectives

Living space climate regulation is a multivariate problem having no unique solution [166]. A number of control methods as the essential part for HVAC system have been proposed and the basic objectives of a control system are as follows [167]:

- High comfort level: Maintain a high comfort level (thermal comfort, air quality and luminance) by learning the comfort zone from user's preference.
- Energy saving: Combine an energy saving control strategy with the comfort conditions control.
- Automatic control: The automatic control system can be utilised to operate HVAC system instead of the amount of human labour in order to improving the HVAC system efficiency and reduce labour costs.

Different approaches for controlling indoor building environments have been developed to satisfy the above requirements and the control systems based on these approaches can be classified into two categories: (1) conventional methods; and (2) computational intelligence technologies [7].

2.2.3 Conventional control

2.2.3.1 Classical controllers

Thermostats were used for the feedback control of the temperature [168]. In order to avoid the thermostats to turn on and off so frequently caused by on/off controller, thermostats with a dead zone were introduced and used. This inevitably results in fluctuation of indoor temperature. In order to solve this problem, Proportional-Integrate-Derivative (PID) controllers were used [168, 169]. With its three-term functionality covering treatment to both transient and steady-state responses, proportional- integral-derivative (PID) control, and P, PI and PD offer the simplest and yet most efficient solution to many real-world control problems. Since the invention of PID control in 1910 (largely owing to Elmer Sperry’s ship autopilot), and the Ziegler–Nichols’ (Z-N) straightforward tuning methods in 1942 [170], the popularity of PID control has grown tremendously.

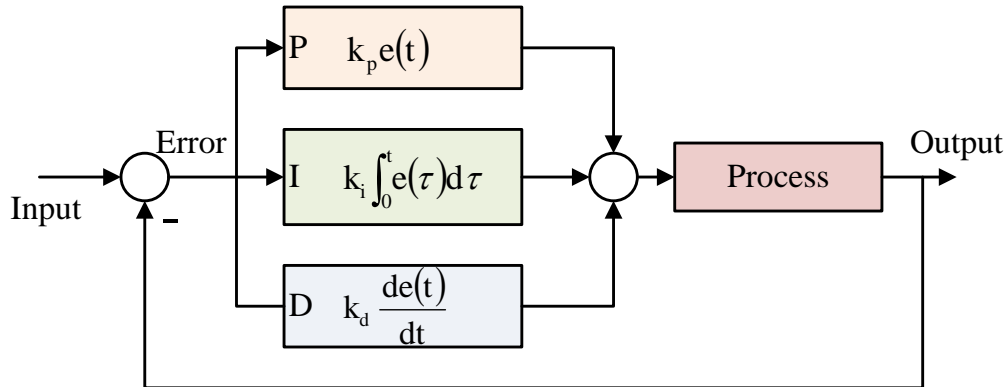

Figure 2-8 Typical PID structure

A standard PID controller as shown in Figure 2-8 is also known as the “three-term” controller, whose transfer function is generally written in the “parallel form” given by (2-3) or the “ideal form” given by (2-4) [171]

$$G(s) = k_p + k_i \cdot \frac{1}{s} + k_d \cdot s \quad (2-3)$$

$$G(s) = k_p \left(1 + \frac{1}{T_i \cdot s} + T_d \cdot s \right) \quad (2-4)$$

Where k_p is the proportional gain, k_i the integral gain, k_d the derivative gain, T_i the integral time constant and, K_d the derivative time constant. The “three-term” functionalities are highlighted as follows [171]:

- The proportional term—providing an overall control action proportional to the error signal through the all-pass gain factor.
- The integral term—reducing steady-state errors through low-frequency compensation by an integrator.
- The derivative term—improving transient response through high-frequency compensation by a differentiator.

It is always considered that increasing the derivative gain, k_d , leads to improved stability and such idea is commonly conveyed from academia to industry. However, the derivative term has been often found to behave against such anticipation particularly when transport delays exist [172, 173]. Frustration in tuning k_d has hence made many practitioners switch off or even exclude the derivative term.

If the control action with an effective range limit is detected by the actuator, then the integrator may saturate and future correction will be ignored until the saturation is offset. Generally, phase lead to offset phase lag caused by integration is provided by the derivative action that is also shortens the period of the control loop and thereby hasten the system recovery from disturbances.

The tuning objectives of PID controller can be summarised as follows [171]:

- controller parameters are tuned such that the closed-loop control system would be stable and would meet given objectives associated with the following:

- stability robustness;
- set-point following and tracking performance at transient, including rise-time, overshoot, and settling time;
- regulation performance at steady-state, including load disturbance rejection;
- robustness against plant modeling uncertainty;
- noise attenuation and robustness against environmental uncertainty.

With given objectives, tuning methods for PID controllers can be grouped according to their nature and usage, as follow [172, 174, 175].

- Analytical methods—Analytical or algebraic relations between a plant model and an objective are used to calculate the PID parameters. This method can lead to an easy-to-use formula and can be suitable for use with online tuning, but it easily leads to inaccurate parameters regulation.
- Heuristic methods—Such methods are evolved from practical experience in manual tuning or from artificial intelligence (including expert systems, fuzzy logic and neural networks). The formulas or rule bases are required to regulate the gains while using such methods that can be employed for online use.
- Frequency response methods—These use frequency characteristics of the controlled process to regulate the PID controller (such as loop-shaping). These are often used while the main concern of controller design is stability robustness.
- Optimization methods—Regarded as a special type of optimal control, numerical optimization method for a single composite objective or computerized heuristics or an evolutionary algorithm for multiple design objectives are used to obtain the PID parameters using. Such type of methods is time-domain methods and mostly applied to offline controls.

- Adaptive tuning methods—One or the combination of the previous methods are applied to online tune the PID parameters automatically .

PID controllers have been widely used in buildings for controlling and operating the HVAC equipments because of its practicality. With advances in digital technology, wide spectrums of choices for control schemes are offered by the science of automatic control. However, more than 90% of industrial controllers are still implemented based around PID algorithms [176], as no other controllers match the PID controller that provides the simplicity, clear functionality, applicability, and ease of use. [177].

In decades, PID controller has been widely used to control and operate different types of HVAC systems because of such reason. One of the important classes of HVAC systems is geothermal district heating system (GDHS) that have been successfully installed and operated in many countries and regions of the world since it results in great energy savings [178]. More attention has been paid on GDHS with regard to improving their energy efficiency and equipment operation.

The manually control and operation of such system is considered as the major challenge. Low working efficiency is caused by manual operation due to oversight in management and imprecise operation etc [179]. Inaccurate control is caused as a result of manual operation that also led to poor heated or over heated and caused energy waste. The proper control strategies should be applied in order to solve such problems and improve energy management.

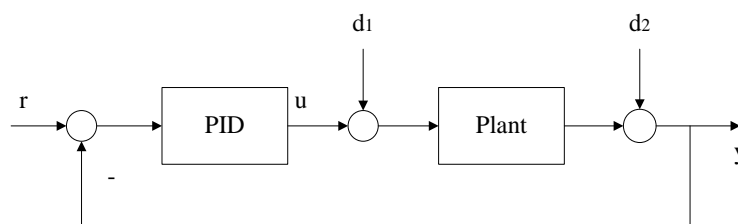

Figure 2-9 Block diagram of novel PID-based controller [180]

Yabanova [180] proposed a PID control strategy as presented in Figure 2-9 to optimise energy efficiency via the flow rate control of the GDHS. This PID controller algorithm meets objectives such as closed-loop stability, adequate performance and robustness by tuning the PID gains to achieve a good balance between performance and robustness. The effectiveness of the proposed control strategy is verified under various operating conditions for a wide range of parametric uncertainties, ambient temperatures and load disturbances. The results shown in Figure 2-10 of their study proved that with the proposed PID controller energy efficiency (maximum) at a specified value (29.01%) is provided. It claimed that the proposed PID controller had the potential for providing more comfortable indoor environments while maintaining lower energy consumption.

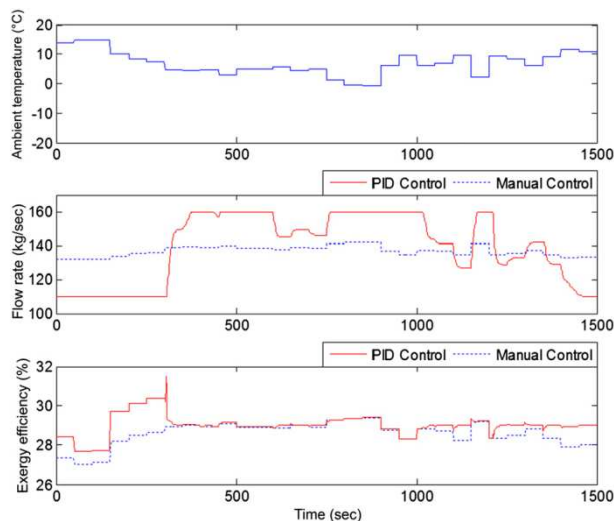

Figure 2-10 Comparison of controlled and manual cases of the AGDHS according to ambient temperature, flow rate of zone 3 and energy efficiency [180]

Generally, GDHSs are controlled by PID controllers [181] in most applications; however, there is growing interest in the use of artificial neural network (ANN) control strategies since some disadvantages are claimed to limit the use of PID controllers.

Firstly, designing and tuning a proportional-integral-derivative (PID) controller appears to be conceptually intuitive, but can be hard in practice, if multiple (and often conflicting) objectives such as short transient and high stability are to be achieved. However, the derivative term is often misunderstood and misused [182]. For example, it has been widely perceived in the control community that adding a derivative term will improve stability but sometimes this perceived is not always valid. Moreover, although the traditional PID controllers improved the control accuracy levels and control performances, setting the parameters for the controllers are not always an easy task. Improper choice of the gains in PID controllers would make the whole system unstable. This issue may be resolved from the adoption of optimal, predictive, or adaptive control techniques. Finally, the HVAC PID controllers are always needed to be designed based on the building models and mismatch of control models can lead to poor or unstable control performance. These may explain why the argument exists that academically proposed tuning rules do not work well on industrial PID controllers.

Researches should be carried out to solve such problems and researchers so far focus on automatic tuning for process control. The present trend in tackling PID tuning problem is to be able to use standard PID structure to meet multiple design objectives while in this project an approach of combining conventional PID controller with intelligent algorithm is proposed.

2.2.3.2 Optimal, predictive, adaptive control and others

(1) Optimal control

A model of the building is necessary while designing the optimal control systems [183-192] or adaptive control strategies [193]. The optimal control includes a model for future disturbances (e.g. solar gains, presence of humans, etc.), which improves thermal comfort mainly by reducing overheating [194–196]. However, mathematic

analysis of these control algorithms always results in nonlinear models. Moreover, these control systems are not very practical because the mathematic models differ from one building to another.

Demand-controlled ventilation (DCV) system is often used for fresh air supply in commercial or public buildings for improving energy efficiency while maintaining acceptable indoor air quality [197, 198]. There are some critical issues of control optimization problems (optimizing control set points) while operating and controlling such HVAC systems. The problems include predicting the system response, and employing appropriate comfort indices to search for the optimal set point(s) according to the system responses. Hence, Optimal control is widely used in HVAC fields [199-202] as an approach to solve these critical issues. Three approaches to predict the system response were concluded based on literatures: 1) simulate the responses of the building and HVAC system to the changes of the control variables based on the detailed physical models [203, 204]; 2) predict response in optimal control applications by developing black-box models or neural network models [205, 206]; and 3) predict response based on the dynamic simplified models and identify model parameters [207]. In the third approach which is most widely of concern, the indoor climate model should be reasonably simple for practicality and the reduction of errors progressively occurred by the actually online measurements can be achieved by using self-tuning techniques can be used to [208].

(2) Karlman Filter

It has been reported that difficulty of monitoring and controlling the indoor climate parameters in a large air-conditioned space is considered as a major challenge in the field of indoor environment management. Then mobile sensor networks strategy was developed to monitor environmental variables such as temperature, RH, salinity, toxins, and chemical plumes. Significant advances have been made in the area of

mobile sensor networks and their applications to environmental sciences [209-216]. An environmental modeling of mobile sensor networks and the control laws developed to maximize the sensory information of mobile sensors was presented in a research. Reduction of uncertainty in the long-term forecast by planning of continuous paths for mobile sensors was addressed in another research [210]. In order to improve the performance of the sensor networks, a control method based on Kalman filter (KF) was proposed [217] and utilized in [211] the environment model.

Mahdi and Jongeun [218] presented a practical solution using KF to address the problem of monitoring indoor climate in a large region by a small number of robotic sensors. In their project, a KF was developed to downsample the environmental process in order to use the cumulative measurements over a time period. In addition, a network of radial basis functions was used in the control process and a continuous-time linear system was introduced. Then, system downsampled by a Kalman filter for a small number of sensors was formulated and the optimal sampling strategies were developed. Finally, the experimental results for monitoring a temperature field of a large region and the proposed scheme was provided to validate by the simulation and experimental results.

However, researches should be carried out taking into account localization errors for the estimation and implementing the experimental setup for multiple monitor and control objects in order to improve their controller's performance.

(3) Adaptive control

Adaptive controllers are able to self-regulate and to be applied to the climate conditions in the various building. More specifically, adaptive fuzzy controllers are regarded as the most promising adaptive control systems for buildings [184, 193, 194]. A research proposed by Nesler [219] introduced an adaptive control strategy of thermal processes in buildings. The standard PI control algorithm is adequate for the

control of heating, ventilating, and air-conditioning (HVAC) processes.

Another application of adaptive control is to employ it to central chilled water systems. These systems are popular for improving the thermal comfort of indoor environment in modern commercial and office buildings, especially in large and high-rise buildings. The adaptive control is used as an approach to solve one of the major challenges: to improve energy efficiency of complex chilled water systems under various working conditions since such systems often contributed a large part of the total electricity energy consumed [8]. Ma and Wang [220] introduced an adaptive control strategy with different configurations in complex building air-conditioning systems to enhance energy efficiencies. In another report presented by Wang and Ma [221] a control strategy was employed to variable speed pumps distributing chilled water to the heat exchangers in super high-rise buildings. The results showed that up to 16.01% of the pumps energy can be saved using this control strategy.

2.2.4 Computational intelligent control

Application of intelligent methods to the building control systems was started in 1930s and the artificial Intelligence (AI) techniques were applied to the control of both conventional and bioclimatic buildings. Intelligent controllers were optimized by the use of evolutionary algorithms and developed for the control of subsystems of an intelligent building [47]. The synergy of the neural networks technology, with fuzzy logic, and evolutionary algorithms resulted in the so-called Computational Intelligence (CI), which now has started to be applied in buildings.

2.2.4.1 Fuzzy logic control

It is well known that the importance of the comfort of human beings gradually increases by the development of technology [222, 223]. In response to ever increasing in demanding for occupant comfort and energy efficiency, the studies related to the design and control of ambient conditions of buildings has been

attracting interest in the last few decades. For example, the desired temperatures and air conditions of shopping-center, offices and different usage areas in a multipurpose building may be different. Hence, flexible design of HVAC systems supplying different demands is substantially to decrease both the first investment cost and the operational cost. In addition, the users' preferences have been taken into consideration and it drove researchers to develop intelligent systems for energy management in buildings (Building Intelligent Energy Management Systems-BIEMS). The intelligent systems are mainly for large buildings like office buildings, hotels, public and commercial buildings, etc. The indoor environmental parameters are monitored and controlled by these control systems in order to minimize the energy consumption and operational costs and fuzzy logic control (FLC) is the control technique used for this purpose.

Recently, their practical applications for HVAC systems have been discussed aiming for performance improvement over classical control [224-228]. In recent years, fuzzy control has been successfully used for controlling and operating a number of physical systems. The human decision making process is modeled and simulated by the fuzzy controllers with a collection of rules. The selection of the membership function that produces maximum performance as a subjective decision is strongly related to fuzzy control performance. The fuzzy control rules and membership function are usually found using trial-and-error method.

Many authors studied Fuzzy logic control (FLC) of HVAC systems [229, 230]. And obtained results were compared with those of PID control and FLC was proved to have better results in some studies. FLC is extensively used in processes where systems are either very complex or exhibit highly nonlinear characters. FLC is one of the schemes that can successfully control the plants while there are difficulties in deriving mathematical models or having performance limitations with conventional linear control methods. The variation of building's type, structure, orientation has

always compromised the performance and convenience of the conventional controllers for HVAC systems as finding a universal mathematical model for such application is extremely difficult. The intelligent systems which are model-free controllers can avoid the issues. This fact is a general innovation in the development of automatic control systems. Human experience is the basis of designing FLC, and this means that mathematical models are not necessary for controlling all systems. Fuzzy logic-based control schemes were implemented for many industrial applications because of such advantage [231]. Many complex industrial processes and domestic appliances were successfully controlled using fuzzy logic control in the recent years [232]. The first FLC algorithm implemented by Mamdani was designed to synthesize the linguistic control protocol of an experienced operator [233].

Soyguder [234] proposed a fuzzy control strategy for an expert HVAC system and the control performance were tested and compared to conventional controllers by using MATLAB/SIMULINK. The obtained results indicate that the performance of the fuzzy adaptive controller is the better than the conventional controllers, in terms of both the steady-state error and the settling time. Their controller ensured the considered expert HVAC system having the minimum settling time and no steady-state errors.

Although the FLC application has been successful compared to the classical controllers, applications of such control methods were limited by the disadvantage of depending on the control experience of the operator. MacVicar-Whelan first proposed some general rules for designing the structure of fuzzy controllers [235] in order to avoid this limitation. Better results for the same system were obtained by using FLC with respect to PID control [236]. In addition, Genetic Algorithms and methods coming from the theory of adaptive control are used to optimize fuzzy controllers. Fuzzy logic control has been used in a new generation of furnace controllers that apply adaptive heating control in order to maximize both energy

efficiency and comfort in a private home heating system [237].

2.2.4.2 Fuzzy P controllers

Many different methods exist to use fuzzy logic in closed-loop control. In the simplest structure of a fuzzy logic controller, the measurement signals from control process are used as the inputs of the controller. The output of the fuzzy logic controller drives the actuators of the process. This pure fuzzy logic system is called fuzzy P controller. The inputs of a fuzzy P controller are predicted mean vote (PMV) and outdoor temperature. Auxiliary heating (AH), auxiliary cooling (AC), and ventilation window opening angle (AW) settings are the controller outputs [238, 239]. These outputs, which are deterministic signals, drive the process actuators.

A global P controller has six inputs (PMV, ambient temperature T_{amb} , CO₂ concentration, change of CO₂ concentration, Daylight Glare Index (DGI), and illuminance (ILL)), and four outputs (AH/AC, SHaDowing, Artificial Lighting, and window opening angle (AW)) [240, 241]. The input-output universe of discourse is covered by the triangular and trapezoidal membership functions. In the rule design, priority is given to passive techniques to obtain indoor comfort. During moderate seasons, the fuzzy rules allow natural cooling through window openings in order to reach thermal comfort by using natural ventilation. During winter and summer, windows are kept closed to avoid thermal losses. The solar gains are controlled to allow passive heating during the winter and cut off excessive heating during the summer.

2.2.4.3 Fuzzy PID controllers

Various types of fuzzy PID (including PI and PD) controllers have been proposed. In the recent literatures, fuzzy PID controllers are divided into two major categories, according to their structures [242, 243]:

(1) Fuzzy PID controller

The first category of fuzzy PID controllers as shown in Figure 2-11 involves the conventional PID controllers in conjunction with a set of fuzzy rules and a fuzzy reasoning mechanism to tune the PID gains online [244]. Fuzzy PID controllers are used as controllers instead of linear PID controller in all classical or modern control system applications. Error between the measured and the reference variable was converted into commands that are applied to the actuator of a process. The information about their equivalent input-output transfer characteristics is important in practical design. Development of control systems for all kind of processes with higher efficiency of the energy conversion and better values of the control quality criteria is considered as the main purpose of research.

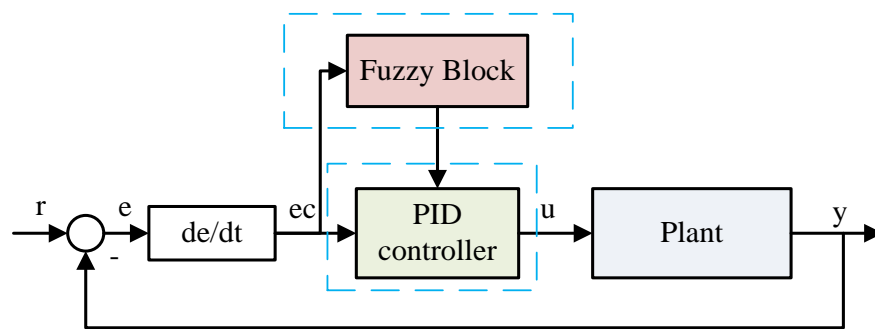

Figure 2-11 A typical fuzzy-PID controller

Literatures of accomplished works related to applications of fuzzy-PID control method by other researchers are reviewed in this section. Evaluation approach is used to develop a methodology for analytical and optimal fuzzy PID controllers [245, 246]. Yame [247] analysed a simple class of Takagi-Sugeno PID controller with respect to conventional control theory and example was presented to show an approach to Takagi-Sugeno fuzzy PID controllers tuning. In the frame of a linear plant control process, Xu presented [248] a tuning method based on gain and phase margins to determine the weighting coefficients of the fuzzy PID controllers. Mamdani fuzzy

PID controllers are studied and presented by numerical simulations in report [249]. Volosencu published his theory on tuning fuzzy PID controllers at international conferences and on journals [250].

Controllers of this type can be used in varying environments. The main drawback of a control system of this type is that it is mainly model-dependent, since it requires human experience with controlling the plant in order to define the range of the proportional gain.

(2) PID type fuzzy logic control

The second category of fuzzy PID controllers is composed of typical fuzzy logic controllers (FLCs) realized as a set of heuristic control rules. In order to be consistent with the nomenclature [250] and to distinguish from the first category of fuzzy PID controllers, FLCs in this category are called PID-like (PI-like or PD-like) FLCs. Most of the research on fuzzy logic control design refers to this category [251-255].

This type controllers are referred to as PID-type FLC's because; their structures are analogous to that of the classical PID controller from input to output relationship point of view. The equivalence of PD-type FLCs and classical PD controllers has been established under the special conditions [256]. Different control tuning methodologies such as auto-tuning, self-tuning, pattern recognition, artificial intelligence, and optimization methods have been proposed in the literature [231]. In order to tune the coefficients of PID-type fuzzy logic controllers (FLCs) Guzelkaya proposed a new approach [234]. In addition, a self-tuning method based on Lyapunov approach was proposed by Wei for a class of nonlinear PID control systems [234]. The self-organizing fuzzy controller has an extension of the rule based fuzzy controller with an additional learning capability [257]. Zhi-Wei proposed a new fuzzy controller structure called PID type fuzzy controller by relating to the conventional PID control theory [258]. Fuzzy PID tuning process is starting with

tuning a linear PID controller, then replacing the tuned linear PID controller with a linear fuzzy controller, and in the end making the fuzzy controller nonlinear and well tuned.

The advantage of a fuzzy PI controller is that it does not have an operating point. The control strategy evaluates the difference between the measured value and the set point and also evaluates the change of this difference in order to decide whether to increment or decrement the control variables of the building. A fuzzy logic controller can implement nonlinear control strategies. If comfort condition (PMV) is ‘cold’ , the increment will be strong, regardless of its tendency, but if the PMV error is small, the tendency is taken into account.

2.2.4.4 Neural network

Neural network controllers are widely used for thermal comfort control [227] and temperature control of hydronic heating systems [259] and such controllers do not require the identification model of the plant. In this section, the neural network is discussed in detail and example of its application in HVAC system control is given.

Neural networks, also known as artificial neural networks (ANNs), are information processing systems with their design inspired by the studies of the ability of the human brain to learn from observations and to generalize by abstraction [260]. Neural networks can be trained to learn arbitrary nonlinear relationships based on the corresponding data. Such control algorithms have been used in many areas such as control, biomedical engineering, pattern recognition and speech processing, etc. Its merits also drew attention of researchers with interest of HVAC and control and ANNs have been applied to HVAC systems problems as well.

Control strategies designed based on the artificial neural network algorithm have been used for simulating and monitoring modern district heating system and resulted in excellent performance. These models are data driven, adaptive, fast in response

and have good accuracy if they are trained with proper data. Several studies including prediction of degradation and impending fault, training of plant/system operators and decision making support for plant/system maintenance, etc can be simulated, monitored, controlled and analysed by the ANNs [261].

ANN has been applied increasingly for advanced thermal control of plant/system. ANN utilizes connectivity and transfer functions between input, hidden, and output neurons, analogous to the learning process of human brain, and has been successfully employed to non-linear systems or systems with unclear dynamics. In particular, ANN models are different from mathematical models such as regression models or proportional integral derivative (PID) controllers since it has adaptability through a self-tuning process. This characteristic make ANN be able to accurately make decisions even though there is no outside expert intervention when unusual perturbations, disturbances, and/or changes in building background conditions occur [262]. ANN control strategy has been proved to have advantages in thermal control in terms of the accurate thermal control with reduced overheating and overcooling, and the improved energy efficiency [263-265]. In some studies [266, 267], start and stop times for heating systems were determined using ANN models.

Neural networks were first trained to model the electrical behaviour of passive and active components/circuits. The trained neural networks, often referred to as neural-network models (or simply neural models), can then be used in high-level simulation and design, providing fast answers to the task they have learned [268, 269]. Conventional control and modelling methods with major disadvantage like empirical models, whose range and accuracy could be limited, or numerical modelling methods, which could be computationally expensive, or analytical methods, which could be difficult to obtain for new devices can be replaced by Neural networks for better performance. Neural-network techniques have been used for a wide variety of HVAC applications. Neural networks have also been used in

impedance matching [270], inverse modelling [271], measurements [272], and synthesis [273]. An increased number of engineers and researchers of air-conditioning field have started taking serious interest in this emerging technology. Neural-network structural issues are introduced next, and the popularly used multilayer perception (MLP) neural network is described in detail. Practical HVAC examples illustrating the application of neural-network techniques to component modelling and circuit optimization are presented.

(1) Structure

A typical neural-network structure has two types of basic components, namely, the processing elements and the interconnections between them. The processing elements are called neurons and the connections between the neurons are known as links or synapses. Every link has a corresponding weight parameter associated with it. Each neuron receives stimulus from other neurons connected to it, processes the information, and produces an output. Neurons that receive stimuli from outside the network are called input neurons, while neurons whose outputs are externally used are called output neurons. Neurons that receive stimuli from other neurons and whose outputs are stimuli for other neurons in the network are known as hidden neurons. Different neural-network structures can be constructed by using different types of neurons and by connecting them differently.

MLP is a popularly used neural network structure. In the MLP neural network, the neurons are grouped into layers. The first and the last layers are called input and output layers, respectively, and the remaining layers are called hidden layers. Typically, an MLP neural network consists of an input layer, one or more hidden layers, and an output layer. For example, an MLP neural network with an input layer, one hidden layer, and an output layer, is referred to as three-layer MLP (or MLP3) as shown in Figure 2-12.

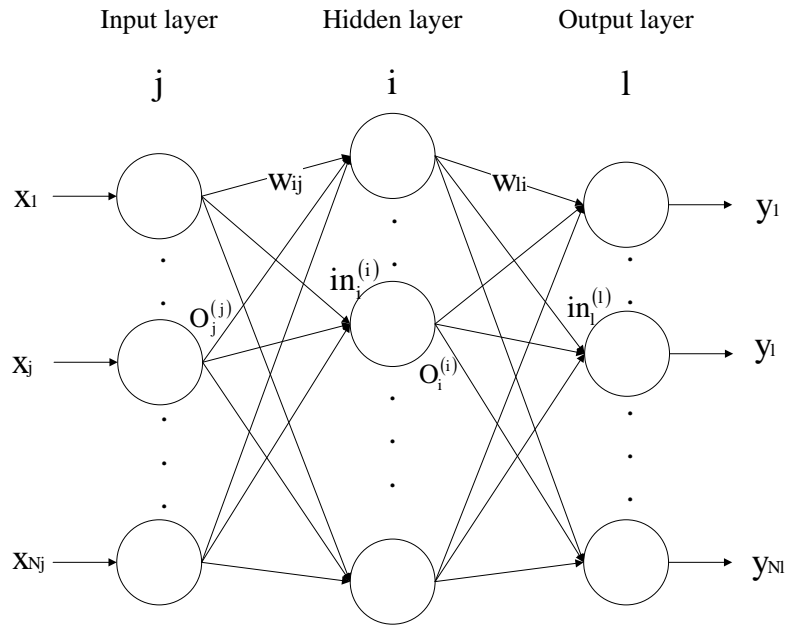

Figure 2-12 Structure of neural network

The number of neurons in the input layer is N_j ; that of the hidden layer is N_i and that of output layer is N_l . w_{ij} is the weight of the link between the j th ($j=[1,2,3,\dots,N_j]$) neuron of input layer and the i th ($i=[1,2,3,\dots,N_i]$) neuron of hidden layer. w_{li} is the weight of the link between the i th neuron of hidden layer and the l th ($l=[1,2,3,\dots,N_l]$) neuron of output layer. x_j is the input and $O_j^{(j)}$ is the output of the j th neuron of input layer. $in_i^{(i)}$ represents the i th external input and $O_i^{(i)}$ is the output of the i th neuron of hidden layer. $in_l^{(l)}$ represents external input and y_l is the output of the l th neuron of output layer.

In the MLP network, each neuron processes the stimuli (inputs) received from other neurons. The process is done through a function called the activation function in the neuron, and the processed information becomes the output of the neuron. For example, every neuron in hidden layer receives stimuli from the neurons of input layer. A typical i th neuron in hidden layer processes the information in two steps. Firstly, each of the input is multiplied by the corresponding weight parameter and the products are added to produce a weighted sum $in_i^{(i)}$ given as:

$$\text{in}_i^{(i)} = \sum_{j=1}^4 w_{ij} O_j^{(j)} \quad (2-5)$$

Secondly, the weighted sum in (2-6) is used to active the neuron's activation function to produce the final output of the neuron $O_i^{(i)}$ expressed as:

$$O_i^{(i)} = f(\text{in}_i^{(i)}) \quad (2-6)$$

This output can in turn, become stimulus to neurons in output layer. The most commonly used hidden neuron activation function is the sigmoid function because it is a smooth switch function that is bounded, continuous, monotonic, and continuously differentiable. Other functions like the arc-tangent function, hyperbolic-tangent function, etc. can be used as the activation function. The sigmoid function is given as:

$$f(x) = \frac{1}{(1 + e^{-x})} \quad (2-7)$$

(2) Size of network

A suitable number of hidden neurons are needed to ensure the neural network to be an accurate model to learn the targeted problem. The number of hidden neurons depends upon the degree of nonlinearity of f and the dimensionality of input x and output y (i.e., values of N_j and N_l in the previous discussed MLP3). More neurons are needed for the highly nonlinear components and systems while fewer are needed for smoother items. However, the universal approximation theorem does not specify as to what should be the size of the MLP network. The precise number of hidden layers and neurons of them required for a given modeling task remains an open question. Either experience or a trial-and-error process can be used to judge the number of hidden neurons. Adaptive processes, which add/delete neurons during training can be

used to determine appropriate number of neurons [274, 275]. The degree of hierarchical information in the original modeling problem can be reflected by the number of layers in a MLP. In general, HVAC system applications commonly require one or two hidden layers MLPs [276] (i.e., three- or four-layer MLPs).

(3) Other Neural-Network Configurations

In addition, there are other ANN structures [277] besides the MLPs, e.g., radial basis function (RBF) networks, wavelet networks, recurrent networks, etc. For example, many control strategies developed using radial basis function neural networks (RBFNNs) [278] as kernel methods have been applied to various areas with success [279-281]. The theoretical analysis of RBFNN structures and algorithms concluded as follows: the orthogonal least square algorithm [282], the approximation capability analysis, the design of RBFNN structure using fuzzy clustering method [283], the error-bound estimation [284], the optimization of RBFNN structure using kernel o method or combined supervised and unsupervised learning method [285], and the use of Fisher ratio for the selection of RBFNN centers [286]. Variables for RBFNNs [287] and RBFNN training [288] can be selected and enhanced using Evolutionary computation algorithms

The nature of the x - y relationship should be analysed and indentified in order to select a neural-network structure for a given application. MLP, RBF, and wavelet networks can be applied to solve the problem of Non-dynamic modeling (or problems converted from dynamic to non-dynamic using methods like harmonic balance). The most popular choice is the MLP since its structure and training are well-established. RBF and wavelet networks can be used when the problem exhibits highly nonlinear and localized phenomena (e.g., sharp variations). Recurrent neural networks [289] and dynamic neural networks [290] can be used to represent time-domain dynamic responses such as those in nonlinear modeling. As one of the

most recent research directions knowledge-based networks [291] are developed by combining existing engineering knowledge with neural networks to be using in the area of HVAC ANN structures.

2.2.4.5 Synergistic neuro-fuzzy techniques

Neuro-fuzzy systems refer to the systems in which the neural network techniques were used in fuzzy technology. Hybrid systems like ANFIS (Adaptive Neuro-Fuzzy Inference System) [292] have been used for prediction and control of the artificial lighting in buildings, following variations of the natural lighting [293]. A well designed predictive control strategy, combined with a modeling of building, users' behavior and the prediction of climate parameters can achieve energy savings and to maintain the indoor conditions in a high comfort level. A neural controller, equipped with the prediction capabilities of neural networks, can be adapted to the hydronic heating control systems and solar buildings [195, 294].

Kanarachos and Geramanis [259] developed and tested an Adaptive Neural Network (ANN) controller for the control of single zone hydronic heating systems. The inputs and outputs of this controller are parameters related to the heating device and the set point temperature. However, this control did not show excellent control performance since no forecasting of either weather parameters or indoor conditions was involved in the control process. A fuzzy-PI controller adapted a neural network was proposed by Egilegor [295] but it did not offer spectacular improvement. Then in a research of Yamada et al. [296], an air-conditioning control algorithm that combines neural networks, fuzzy systems, and predictive control was developed. This system included the prediction of weather parameters and the number of occupants that predictions are then used to estimate building performance in order to guarantee a satisfactory comfort and achieve energy saving. It presents that better control performance can be achieved by combining the merits of both conventional and advanced control methods.

2.2.4.6 Optimization of fuzzy logic controllers

The gradient-based optimization technique determines search directions for minimization of an objective (or error) function. This technique can be used to minimize energy consumption in distributed environmental control systems while maintain a high occupant comfort level [297].

The most widely used derivative-free techniques are: Genetic Algorithms (GAs), simulated annealing, random search and downhill simplex method. GAs are adaptive search and optimization algorithms that work by mimicking the principles of natural genetics [298]. These algorithms are different from traditional search and optimization methods used in engineering design problems. Fundamental ideas are borrowed from genetics and are used artificially to construct search algorithms that are robust and require minimal problem related information. Alcalá [299] used GAs to develop smartly tuned fuzzy logic controllers for HVAC systems, for the purpose of energy performance and indoor comfort improvement. Lam [300] proposed a classifier system with GAs in on-line control for an air conditioning system in order to make the air conditioning controller a self-learning control system.

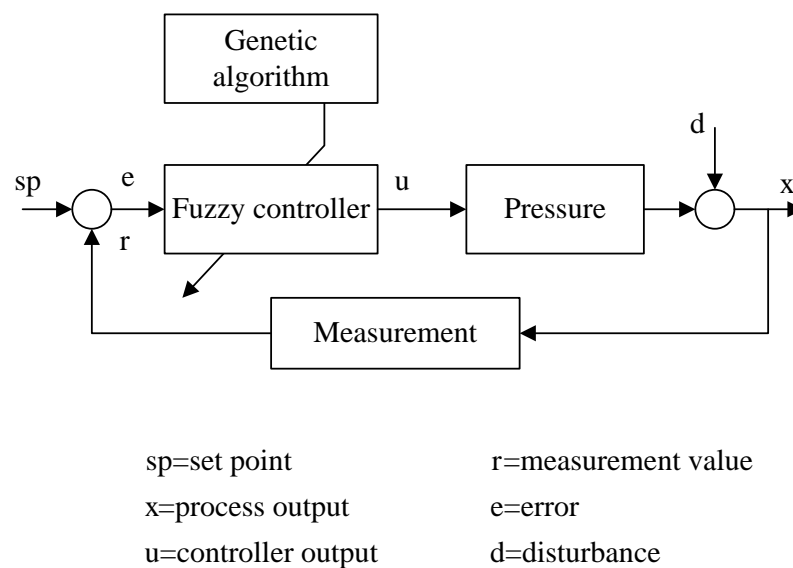

Figure 2-13 Fuzzy controller using genetic algorithm structure [303]

Altinten [303] proposed a fuzzy control designed using genetic algorithm as presented in Figure 2-13 for temperature control. The fitness function for GA is chosen as the integral of the absolute value of the error (IAE) and used to define the fuzzy membership function as shown in Figure 2-14 and Figure 2-15. By using fuzzy parameters specified at constant temperatures, the efficiency of the fuzzy controller with GA was examined by simulation and experimentally. It was seen as in Figure 2-16 that GA is able to tune the fuzzy controller efficiently for different situations and therefore to control the temperature.

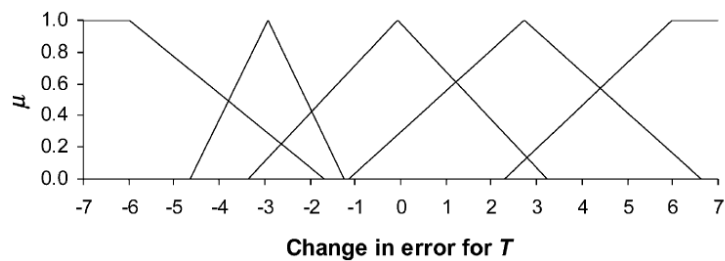

Figure 2-14 The fuzzy membership functions for change in error for T [303]

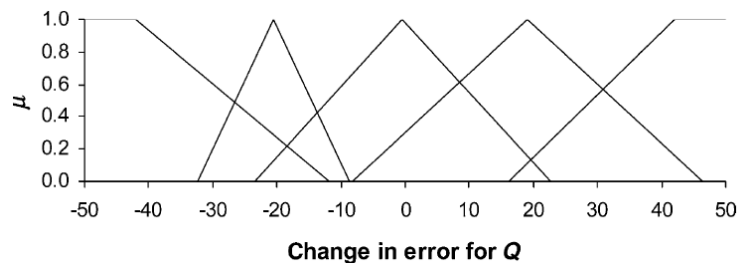

Figure 2-15 The fuzzy membership functions for change in error for Q [303]

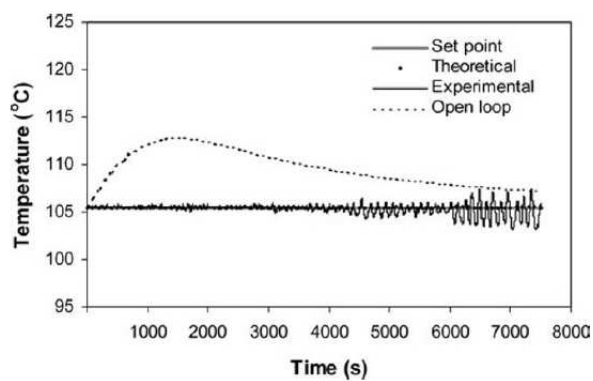

Figure 2-16 Genetic fuzzy temperature control [303]

The previous discussion and examples show that intelligence control systems have been used for building environment control and energy saving. According to these references, the advanced control algorithms can achieve significant energy efficiency compared with classical control systems; however, the percentage of the energy saving depends on not only the control technology but also weather conditions, building characteristics and user preferences.

2.3 Shortcomings of current control methods and future perspectives

The limitation of current control methods for HVAC systems can be summarised as follows [7]:

- Bespoke design. Conventional control methods like PID control need to be designed based on the building model and the mismatch of model will cause poor control performance. Even for an adaptive controller, such knowledge is still required at extent.
- Difficulty to put into applications. The weak points of fuzzy controllers are due to the difficulty of defining accurate membership functions and lack of the systematic procedure for the transformation of the expert knowledge into the rule base. Moreover, tuning parameters consumes a lot of time. Neural network can automatic the process of tuning parameters, significantly reduce development time and results in a better performance. However, in neural nets, both knowledge extraction and knowledge representation are difficult.
- While using advantage controls, an expert knowledge library or operators with specific skills are needed, and this limits the use of such controllers.
- Lag behind the development of HVAC technologies. Current control algorithms do not provide specific control for these HVAC systems and do not have excellent control performance.

It can be seen that the development of control technologies in the following areas is desirable to address the shortcomings of the current control technologies for HVAC systems [7]:

- New control strategies for advanced HVAC systems like DOAS in order to make them work more effectively and provide better performance.
- Model-independent control strategies for general purpose use which can reduce the development time for model matching and parameters tuning. This is particularly valuable now as HVAC systems are widely used in buildings.
- Inclusion of other signals which have strong link with the indoor environment quality in the control process to improve the performance in indoor environment quality control and energy management.

The development may be achieved from the following approaches [7]:

- New control approaches may merge both the conventional and advanced control methods. There are two possible ways: a method by which individual merits are combined, and another by which analogies between these are overlapped.
- The control algorithm which can monitor occupancy level and adapt the variation of the air-conditioned zone in order to improve indoor air quality and energy efficiency.
- The indoor air pollutant level should be included in control process, which will enable to control air changing rate accurately to improve the energy efficiency of the systems.
- More intelligent strategy for monitoring human behaviour, so that it can be adapted into the control process for more accurate control response to the requirement for occupant comfort.

- The control process which does not require intervention of the users with specific skills or knowledge.
- Closed-loop, real-time and on-line learning ability. The IEQ performance evaluation system could be included to make a control process have the self learning and modifying ability.

2.4 Summary

The people's living standard of indoor environment has been increasing due to the fact that people spend most of their time indoors. Subjective comfort of persons in a room depends on many factors: temperature, humidity and air circulation; smell and respiration; touch and touching; acoustic factors; sight and colours effect; building vibrations; special factors (solar-gain, ionization); safety factors; economic factors; unpredictable risks. The heating, ventilating and air-conditioning systems have been widely used as a result of such condition and the trend of implement of HVAC systems lead to another major problem in the world, increasing energy cost. In order to satisfy both occupant comfort and the requirement of energy saving, studies related to both of the aspects have been carried out by researchers of HVAC technologies, thermal comfort analysis, control engineering.

In this chapter, the main problems that researchers are currently trying to solve including indoor thermal comfort, indoor air quality and energy efficiency were introduced.

The first important concept thermal comfort is known as 'the condition of mind that expresses satisfaction with the thermal environment and is assessed by subjective evaluation' [10]. It is a complex concept that is affected by various parameters, both objective and subjective. Studies have been done by both physicists and engineers and thermal comfort indices were introduced to understand and set the international and local indoor temperature and humidity standards. The introduction of these

thermal comfort indices are very useful. For example, design of heating systems must take account of nationally specified criteria, the recommended of which are given based on widely used indices, PMV and PPD model. Relevant studies showed that the air-conditioning systems are able to improve the indoor thermal comfort and with well designed control strategy, performance of the air-conditioning system can be further enhanced.

Then, the indoor air quality referring to the air quality within and around buildings and structures are introduced. Survey studies [39-41] showed that indoor air quality strongly relates to the health and comfort of building occupants. Poor indoor air quality could lead to various human disease [42-110]. The indoor air quality can be affected by variety of gases most of which are considered as indoor air pollutant such as monoxide, radon, and volatile organic compounds, particulates, microbial contaminants or any mass or energy stressor that can induce adverse health conditions. Among these air pollutants, CO₂ is always chosen as the control single in HVAC control strategies since when CO₂ is under a critical level most of the other air pollutants are keep at acceptable levels. Studies related to indoor air quality analysis and enhancement claimed that the HVAC systems are able to improve the indoor air quality and with well designed control strategy, performance of the air-conditioning system can be further enhanced.

In addition, the energy efficiency issue in buildings due to widely implement of HVAC systems is discussed. The objective of energy efficiency in buildings is to reduce the amount of energy required to provide an acceptable indoor environment. The demanding caused by such condition has a significant impact on the sustainable development as it comes with significantly increasing use of energy. This issue could be addressed by increasing energy efficiency of these systems, and improving HVAC control technology perhaps is one of the ways to reduce the impact. Literature of relevant studies [161] proved the idea that proper control strategy is able improve the

performance of HVAC systems in order to ensure better energy efficiency while maintaining comfortable and health indoor environment for people working or living in it.

Hence, finally the current control methods that have been or are going to be employed for HVAC systems were introduced. There are basically two categories of control technologies: conventional control and computational intelligent control. Then, important controllers under both the categories that have been applied to HVAC systems are discussed in detail and case studies were presented. Based on the review, the most popular controllers are known as PID controller of conventional control and fuzzy logical neural networks of intelligent control.

In order to achieve better control performance, the control object including indoor temperature, humidity and air quality should be understood better. As the challenges have been addressed, it is easier for HVAC control system design engineers to choose a proper control method and to design the optimized control algorithm. The difficulties in indoor environment controlling would be as follows:

- Difficult to predict the system response, and to employ appropriate comfort indices to search for the optimal set point(s) according to the system responses.
- Complex HVAC systems are hard to be analysed and controlled
- Time delay.
- Disturbances always exist in control process in both thermal comfort control and indoor air quality control.
- HVAC systems always response lag behind the indoor environment change.
- The existence of mismeasurement of control signal value is considered as one of the major problems of indoor air quality.

- The fact that control signals sometimes depend on each other makes the steady state of control performance unstable.

According to the literature researches and reported data, the performance of current control methods on different control objects was evaluated. A summary showed that one controller is difficult to achieve all control goals and to have excellent control performance for all control signals. For instance, PID might be good at temperature control, however, it has poor control performance for thermal comfort control which includes two control signals: temperature and humidity. Hence, the controller must be designed properly based on well analysis and understanding of both the control technology itself and the control object. The mentioned control systems and the most important technical issues regarding these control methods are listed and summarized in Table 2-8. For example, in the column of IAQ control (CO₂), the symbol √ denotes that the advanced control techniques can achieve significant IAQ control compared with the classical control systems. This table can be helpful choose the proper control method to use while designing the controller for different purposes. In addition the drawbacks and future perspectives of current control methods are summarised in the previous section.

Table 2-8 Comparison of control systems [7]

Control system	Temperature control	Thermal comfort control	IAQ control	Visual comfort control	Energy consumption	Ventilation control
ON/OFF	√	–	–	–	–	–
PID	√	–	–	–	√	√
Predictive control	√	√	–	–	√	√
Fuzzy P control	√	√	–	√	√	√
Fuzzy PI control	√	√	–	√	√	√
Fuzzy PID control	√	√	√	√	√	√
Neural network control	√	√	√	–	√	√
Optimal control	√	–	–	–	√	√

√ - the control method has excellent performance on the control objective

– - the controller needs to be modified to achieve the control goal

The main parts that this project is focused on based on this analysis can be summaries as follows:

- New control approaches may merge both the conventional and advanced control methods. There are two possible ways: a method by which individual merits are combined, and another by which analogies between these are overlapped.
- The control algorithm which can monitor occupancy level and adapt the variation of the air-conditioned zone in order to improve indoor air quality and energy efficiency.
- The indoor air pollutant level should be included in control process, which will enable to control air changing rate accurately to improve the energy efficiency of the systems.
- Multiple loop control that ensure the stable steady state of the designed controller and this will also helpful for protect air-conditioning equipment.
- The control process which does not require intervention of the users with specific skills or knowledge.
- Closed-loop, real-time and on-line learning ability. The IEQ performance evaluation system could be included to make a control process have the self learning and modifying ability.

Chapter 3 Controllers design

In the previous chapter, the current control technologies that have been widely used for temperature control, humidity control and indoor air quality control in built environment to improve the indoor environment were reviewed. Then, the shortcomings and problems of current control strategies are summarised. These problems limit the use of control strategies for HVAC systems. In order to address these issues, future perspectives and approaches to improve the control performance of IEQ control are discussed and concluded [7]. In this project, three controllers are designed for different purposes: indoor temperature control, indoor humidity control, indoor air quality control. By control indoor temperature, humidity and air quality to the targeted level, a comfortable and healthy indoor climate can be guaranteed. The proposed controllers are designed mainly based on the following considerations:

- New control approaches may merge both the conventional and advanced control methods. There is a possible way: a method by which individual merits are combined.
- In this research, PID control is utilized because of its practicality. But its control performance is mainly based on the PID parameters and improper selection of them will lead to poor control performance. Hence intelligent controller is designed to regulate the PID parameters automatically to ensure the optimized control output.
- The indoor air pollutant level should be included in control process, which will enable to control air changing rate accurately.
- The control process that does not require intervention of the users with specific skills or knowledge.

- Closed-loop, real-time and on-line learning ability. The IEQ performance evaluation system could be included to make a control process have the self-learning and modifying ability.

It is very complicated work to control indoor temperature, relative humidity and CO₂ by using a multiple loop controller. Three controllers, each for individual control signal, are developed in this research instead of using one multiple controller. Moreover, it is still difficult to design and apply model independent controller to real-time indoor climate control based on recent researches but improving adaptability is considered as a way to increase controllers' practicality. Hence, a proper mathematical model of the controlled object is necessary while designing and testing the control strategy. In this chapter, the mathematical models of the indoor climate including indoor temperature model, indoor humidity model and indoor CO₂ level model and mathematical models of air-conditioning equipments including heater and humidifier are discussed in detail. Then the controllers for different purposes will be introduced.

3.1 Mathematical model of indoor climate

In this section, the mathematical model of indoor climate including indoor temperature, indoor humidity, indoor air quality, heater and humidifier in a medium size office as shown in Figure 3-1 (a) is established. The length of the room is 3m; width is 2m; height is 2.5; the thickness of wall is 0.3m and the material is common brick. The outdoor environment is cold and dry and the heating and humidifying work needs to be done for improving acceptable indoor climate. The outdoor air is heated and humidified by the heater and humidifier located at the end of the air supply channel and then introduced to the indoor environment with the desired temperature and humidity level as presented in Figure 3-1 (b).

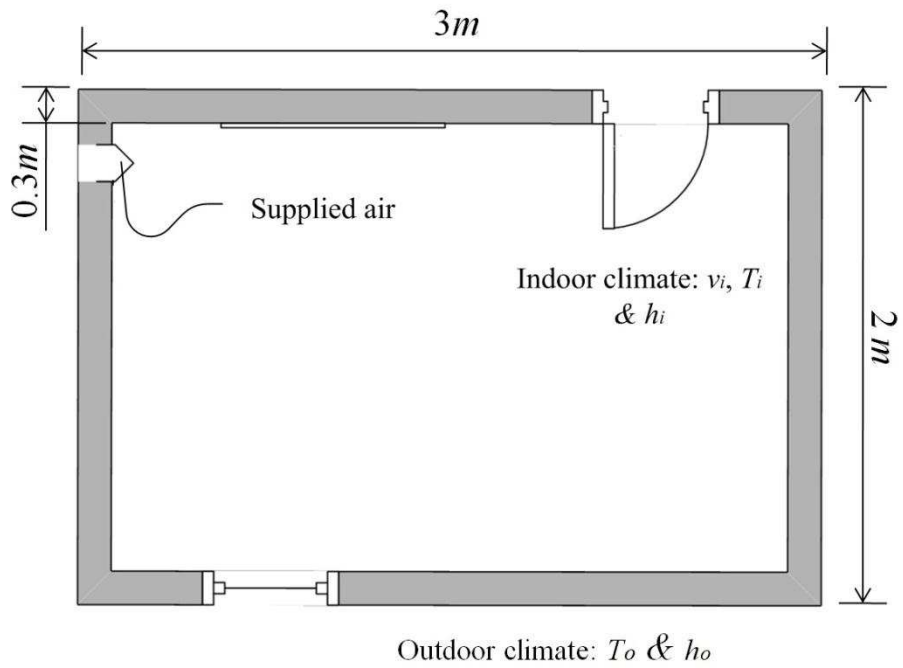

(a)

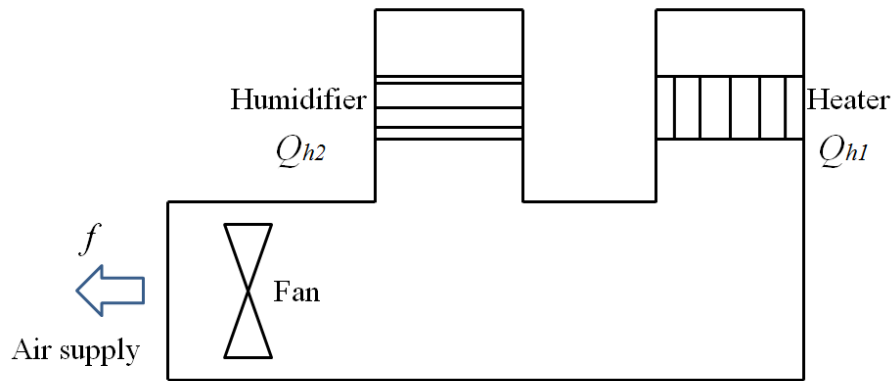

(b)

Figure 3-1 (a) Air-conditioned zone (b) Air-supply channel

3.1.1 Mathematical model of indoor temperature

The indoor temperature is affected by the air temperature of the indoor climate, heater, volume of the room and heat loss from the wall while not considering the influence of the humidity as presented in Figure 3-1. Hence, the indoor temperature

can be expressed as follows based on the energy conservation principle:

$$\rho_a \cdot C_p \cdot V_i \cdot \frac{dT_i}{d\tau} = Q_{hl} - U_w \cdot A_w \cdot (T_i - T_o) \quad (3-1)$$

where ρ_a (kg/m^3) is the density of air, C_p ($\text{J}/\text{kg}\cdot^\circ\text{C}$) is the heat capacity of air, V_i (m^3) is the volume of the room, T_i ($^\circ\text{C}$) is the indoor temperature, τ (s) is time, Q_{hl} (W) is the work rate of the heater, T_o ($^\circ\text{C}$) is the outdoor temperature, A_w (m^2) is the area of the wall and U_w ($\text{W}/\text{m}^2 \cdot ^\circ\text{C}$) is the overall heat transfer coefficient for the wall. U_w can be calculated as [301]:

$$U_w = \frac{1}{\frac{1}{h_A} + \frac{d_w}{K_b} + \frac{1}{h_B}} \quad (3-2)$$

where K_b ($\text{W}/\text{m} \cdot ^\circ\text{C}$) is the thermal conductivity of common brick work and d_w (m) is the thickness of the wall, h_A and h_B ($\text{W}/\text{m}^2 \cdot ^\circ\text{C}$) are the individual convection heat transfer coefficients for fluids on each side of the wall. In this case, we can consider $h_A=h_B=h_{\text{air}}$ and h_{air} is the convection heat transfer coefficients of air.

Equation (3-2) can be transfer into:

$$U_w = \frac{1}{\frac{2}{h_{\text{air}}} + \frac{d_w}{K_b}} \quad (3-3)$$

Equation (3-1) can be transferred as follows by using Laplace transform:

$$T_i(s) \cdot s = \frac{1}{\rho_a \cdot V_i \cdot C_p} \cdot Q_{hl}(s) - \frac{U_w \cdot A_w}{\rho_a \cdot V_i \cdot C_p} \cdot (T_i(s) - T_o(s)) \quad (3-4)$$

Then the equation can be described as:

$$\left(s + \frac{U_w \cdot A_w}{\rho_a \cdot V_i \cdot C_p} \right) \cdot T_i(s) = \frac{1}{\rho_a \cdot V_i \cdot C_p} Q_{h1}(s) + \frac{U_w \cdot A_w}{\rho_a \cdot V_i \cdot C_p} \cdot T_o(s) \quad (3-5)$$

Assume $\frac{U_w \cdot A_w}{\rho_a \cdot V_i \cdot C_p} \cdot T_o(s) = 0$, then (3-5) can be transferred and simplified as:

$$\frac{T_i(s)}{Q_{h1}(s)} = \frac{k_{it}}{T_{it} \cdot s + 1} \quad (3-6)$$

where $T_{it} = \frac{\rho_a \cdot V_i \cdot C_p}{U_w \cdot A_w}$ is the time constant, $k_{it} = \frac{1}{U_w \cdot A_w}$ is the gain of the transfer

function.

The mathematical model of indoor temperature without the influence of indoor humidity can be described by the transfer function (3-4). Then the indoor temperature change related to the humidity change can be removed by the decoupling algorithm discussed in section 3.2

3.1.2 Mathematical model of indoor humidity

In this project, the indoor air humidity is affected by the humidity of the supplied air, initial indoor air humidity and humidifier work rate as shown in Figure 3-1. The indoor humidity can be expressed by using energy conservation principle:

$$\rho_a \cdot V_i \cdot H \cdot \frac{dh_i}{d\tau} = Q_{h2} - f \cdot H \cdot \rho_a \cdot (h_i - h_o) \quad (3-7)$$

where $H(\text{kJ/kg})$ is the vapor enthalpy, $f(\text{m}^3/\text{s})$ is the volume flow rate, $h_i(\text{g/kg})$ is the indoor humidity, $h_o(\text{g/kg})$ is the outdoor humidity and $Q_{h2}(\text{W})$ is the work rate.

Using Laplace transform and equation (3-7) can be transferred into:

$$H_i(s) \cdot s = \frac{1}{\rho_a \cdot V_i \cdot H} \cdot Q_{h2}(s) - \frac{f}{V_i} (H_i(s) - H_o(s)) \quad (3-8)$$

And then the equation can be described as:

$$\left(s + \frac{f}{V_i}\right) \cdot H_i(s) = \frac{1}{\rho_a \cdot V_i \cdot H} \cdot Q_{h2}(s) + \frac{f}{V_i} \cdot H_o(s) \quad (3-9)$$

Assume $\frac{f}{V_i} \cdot H_o(s) = 0$ in order to simplify the equation (3-9) and the transfer

function of indoor humidity can be expressed as:

$$\frac{H_i(s)}{Q_{h2}(s)} = \frac{k_{ih}}{T_{ih} \cdot s + 1} \quad (3-10)$$

where $T_{ih} = \frac{V_i}{f}$ is the time constant and $k_{ih} = \frac{1}{\rho_a \cdot f \cdot H}$ is the gain of the transfer

function.

3.1.3 Transfer matrix for indoor temperature and humidity

Since the indoor temperature change and indoor humidity change are related to each other, it is necessary to analyse the two variables together and to establish the transfer matrix of indoor temperature and humidity.

In this project, the control variables (system outputs) are indoor temperature and indoor humidity, and the output matrix is $Y = [T_i \ H_i]^T$, where T_i is the indoor temperature and H_i is the indoor humidity. The heater working power and humidifier working power are the inputs. They control the temperature and humidity controllers and also known as the controllers' outputs. Hence the input matrix is $X = [Q_{h1} \ Q_{h2}]^T$, where Q_{h1} is the heater working power (output of indoor

temperature controller) and Q_{h2} is the humidifier work power (output of indoor humidity controller). The indoor temperature and humidity model is a two-input two-output system as shown in Figure 3-2.

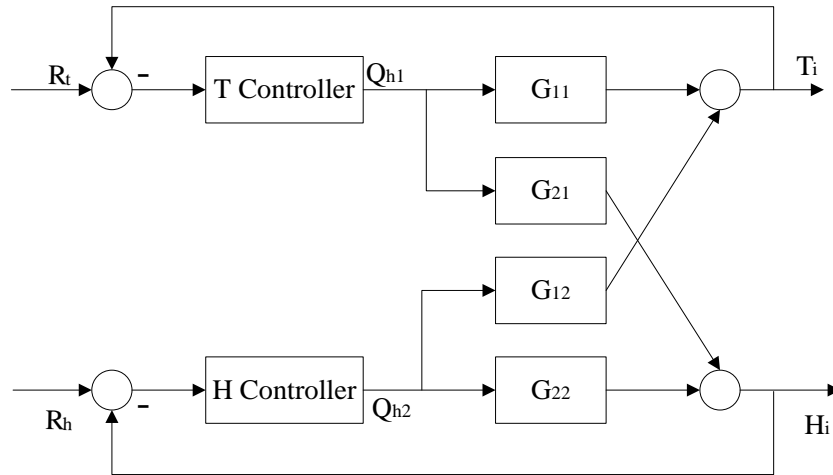

Figure 3-2 Indoor temperature and humidity model

The transfer matrix described the relationship between Y and X is given as:

$$\begin{bmatrix} T_{ic} \\ H_{ic} \end{bmatrix} = \begin{bmatrix} G_{11} & G_{12} \\ G_{21} & G_{22} \end{bmatrix} \begin{bmatrix} Q_{h1} \\ Q_{h2} \end{bmatrix} \quad (3-11)$$

where G_{11} , G_{12} , G_{21} and G_{22} are the transfer functions of the matrix. Since the flow rate of the air from the air supply channel f is a constant value as shown in Figure 3-1, the humidity level of the air from air supply channel $h_{a,o}$ is not influenced by heater's working power but is only affected by the humidifier's working power. That means that the indoor humidity level is not affected by the heater's working power.

$$G_{21} = 0 \quad (3-12)$$

Equation (3-11) can be simplified as follows:

$$\begin{bmatrix} T_{ic} \\ H_{ic} \end{bmatrix} = \begin{bmatrix} G_{11} & G_{12} \\ 0 & G_{22} \end{bmatrix} \begin{bmatrix} u_{h1} \\ u_{h2} \end{bmatrix} \quad (3-13)$$

The detail of transfer function G_{11} , G_{12} and G_{22} are discussed in section 3.2

3.1.4 Mathematical model for indoor air quality (CO₂)

There are many different types of indoor pollutant in indoor environment and it is not possible to monitor and control all of them, so one dominant contaminant, which requires the greatest amount of fresh air to dilute to an acceptable level, is selected as the control signal in our control strategy and CO₂ is used as the indicator in this project. By controlling CO₂ to the desired levels, most of the other indoor air pollutants can be maintained at acceptable levels. The indoor CO₂ concentration can be given as follows [165]:

$$V_i \frac{dC_{ico_2}}{d\tau} = E_{co_2} - \lambda \cdot V_i \cdot C_{ico_2} - f \cdot (C_{ico_2} - C_{oco_2}) \quad (3-14)$$

Then it can be transferred into:

$$C_{ico_2}(t) = \frac{E_{co_2} + f \cdot C_{oco_2}}{\lambda \cdot V_i + f} \cdot (1 - e^{-t/T_{ico_2}}) + C_{ion} \cdot e^{-t/T_{ico_2}} \quad (3-15)$$

where $T_{ico_2} = \frac{V_i}{\lambda \cdot V_i + f}$ is time constant of the system.

3.2 Decoupling control strategy for temperature and humidity

In this project, the indoor temperature and indoor humidity are controlled by the working power of heater and humidifier as presented in Figure 3-1. When the temperature is different from the desired value, the heater's working power is going to change as demanded; and when indoor humidity is different from the set-point, the humidifier's working rate is going to change to meet the control requirement. The

indoor temperature and humidity is a complicated system that they are related to each other as shown in Figure 3-2 and it can be seen that when the indoor humidity changes, the indoor temperature changes as a result. Hence, single loop control strategy for indoor temperature and humidity control cannot meet the control requirement and will cause poor control performance and it is necessary to design a decoupling strategy to remove the relation between indoor temperature and humidity. Once the indoor temperature and humidity are independent to each other, the single loop controllers can be used for indoor temperature and humidity control and acceptable control performance can be gained with proper control method. In this section, the decoupling strategy for this project is discussed in detail.

A typical two-input two-output system that its variables affect each other is presented in Figure 3-3. R_1 and R_2 are the system inputs. X_1 and X_2 are the controllers' outputs. Y_1 and Y_2 are the system outputs. The input matrix is $X = [Q_{h1} \quad Q_{h2}]^T$, where Q_{h1} is the heater working power and Q_{h2} is the humidifier work power (output of indoor humidity controller). $Y = [T_i \quad H_i]^T$, where T_i is the indoor temperature and H_i is the indoor humidity.

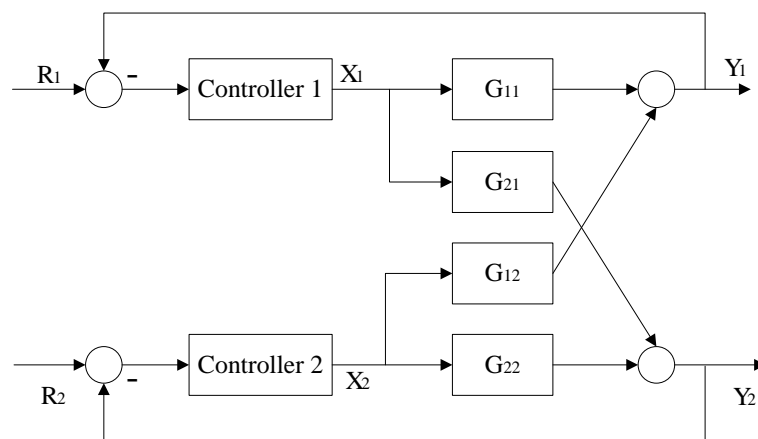

Figure 3-3 A two-input two-output system

The transfer function between system outputs and controllers' outputs is give by:

$$\begin{bmatrix} Y_1 \\ Y_2 \end{bmatrix} = \begin{bmatrix} G_{11} & G_{12} \\ G_{21} & G_{22} \end{bmatrix} \begin{bmatrix} X_1 \\ X_2 \end{bmatrix} \quad (3-16)$$

We can add decoupling elements F_{11} , F_{12} , F_{21} and F_{22} between the control object and designed controller as shown in Figure 3-4. Then the transfer matrix (3-16) becomes:

$$\begin{bmatrix} Y_1 \\ Y_2 \end{bmatrix} = \begin{bmatrix} G_{11} & G_{12} \\ G_{21} & G_{22} \end{bmatrix} \begin{bmatrix} F_{11} & F_{12} \\ F_{21} & F_{22} \end{bmatrix} \begin{bmatrix} X_1 \\ X_2 \end{bmatrix} \quad (3-17)$$

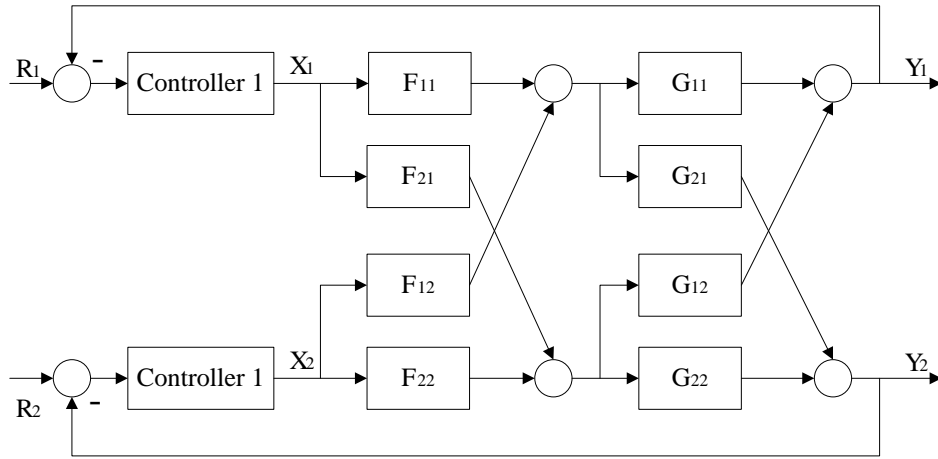

Figure 3-4 A two-input two-output system with decoupling design

If the decoupling matrix meets the following requirement:

$$\begin{bmatrix} F_{11} & F_{12} \\ F_{21} & F_{22} \end{bmatrix} = \begin{bmatrix} G_{11} & G_{12} \\ G_{21} & G_{22} \end{bmatrix}^{-1} \quad (3-18)$$

Then transfer matrix (3-17) can be transferred into:

$$\begin{bmatrix} Y_1 \\ Y_2 \end{bmatrix} = \begin{bmatrix} G_{11} & 0 \\ 0 & G_{22} \end{bmatrix} \begin{bmatrix} X_1 \\ X_2 \end{bmatrix} \quad (3-19)$$

And the two-input two-output system can be equivalent to two single-input single-output (SISO) systems as shown in Figure 3-5. In this way, the relation

between the two variables of the system is removed and they are independent to each other. Then one single loop controller can be utilised for each SISO system.

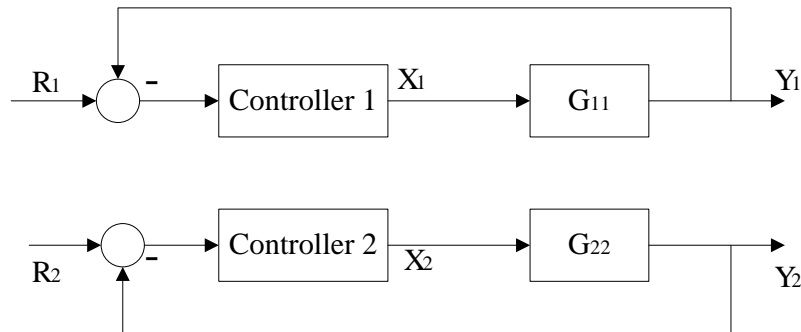

Figure 3-5 Equivalent system of two-input two-output system

In this project, the indoor temperature and humidity model can be expressed by equation (3-13) and it can be seen that $G_{21} = 0$, so the flow chart of the indoor temperature and humidity model is presented in Figure 3-6. The model has two control loops: a temperature control loop and a humidity control loop. The indoor humidity is only affected by the humidifier's working power. However, it is very clear that the indoor temperature is not only affected by the heater's working power, but also affected by the humidifier's working power. That means single-input single out-put control strategy is not able to control indoor air temperature properly as long as the indoor temperature is affect by other variables other than heater's working power. Hence, our objective is to ensure that indoor temperature only changes based on the heater's working power. The proposed solution in this project is to design a decoupling strategy to remove the effect of G_{12} in order to make indoor temperature and humidity independent to each other.

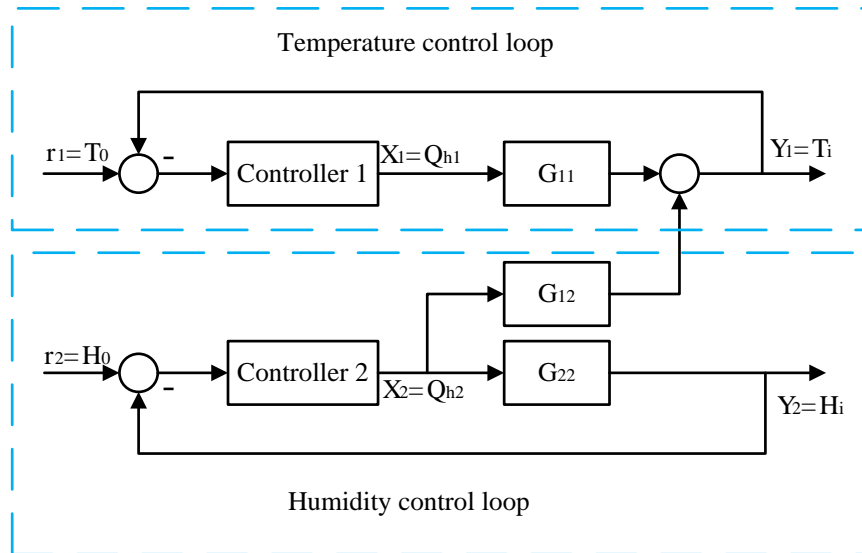

Figure 3-6 Indoor temperature and humidity system

In order to achieve the objective, a decoupling control element is designed as follows:

$$F_{12}(s) = \frac{G_{12}(s)}{G_{11}(s)} \quad (3-20)$$

Then, apply the decoupling control element to the indoor temperature and humidity system as shown in Figure 3-7. The decoupling element is added between controller 2 and control objects and builds a connection between the two loops.

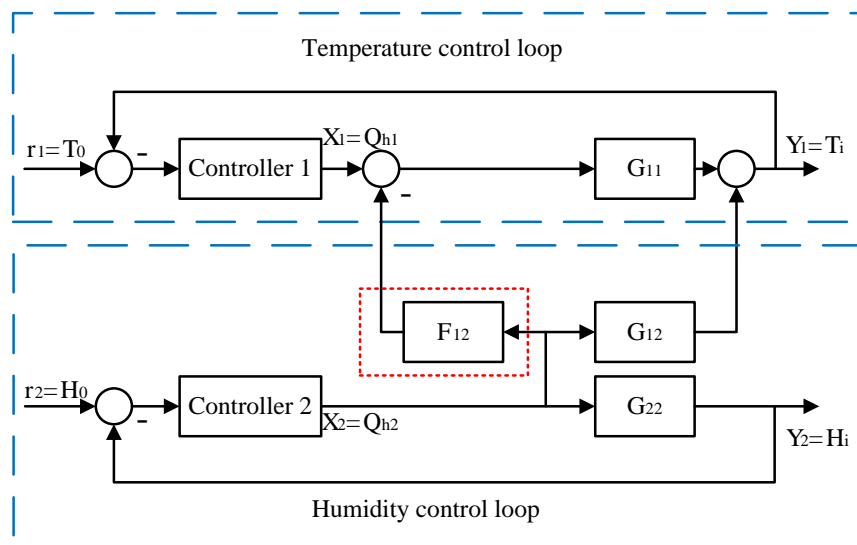

Figure 3-7 The indoor temperature and humidity system with decoupling strategy

The output T_i can be calculated by using equation (3-21) based on the structure of the indoor temperature and humidity system with decoupling control strategy presented in Figure 3-7.

$$T_i = G_{11} \cdot (Q_{h1} - F_{12} \cdot Q_{h2}) + G_{12} \cdot Q_{h2} = G_{11} \cdot Q_{h1} \quad (3-21)$$

Using the temperature transfer function (3-6) we can get: $G_{11} = \frac{k_{it}}{T_{it} \cdot s + 1}$

Then, the output H_i can be calculated as follows:

$$H_i = G_{22} \cdot Q_{h2} \quad (3-22)$$

Using the humidity transfer function (3-10) we can get: $G_{22} = \frac{k_{ih}}{T_{ih} \cdot s + 1}$

Hence, the transfer matrix of this system with decoupling strategy can be expressed as follows:

$$\begin{bmatrix} T_{ic} \\ H_{ic} \end{bmatrix} = \begin{bmatrix} \frac{k_{it}}{T_{it} \cdot s + 1} & 0 \\ 0 & \frac{k_{ih}}{T_{ih} \cdot s + 1} \end{bmatrix} \begin{bmatrix} Q_{h1} \\ Q_{h2} \end{bmatrix} \quad (3-23)$$

Equation (3-21) and transfer matrix (3-23) presents that the system output, indoor temperature is only affected by one variable, heater's working power and the other system output, indoor humidity is only affected by one variable, humidifier's working power. So this system can be equivalent to one SISO indoor temperature control loop and one SISO indoor humidity control loop. Then it is possible to control the indoor temperature and indoor humidity by using two single loop controllers.

The length of the room is 3m; width is 2m; height is 2.5; the thickness of wall is 0.3m and the material is common brick; and assume the desired indoor temperature is 20°C. Hence $V_i = 15\text{m}^3$, $A_w = 25\text{m}^2$, $d_w = 0.3\text{m}$ and the volume flow rate $f = 0.01\text{m}^3/\text{s}$. Then by checking the coefficient table [302] we can get: $\rho_a = 1.2\text{kg}/\text{m}^3$, $C_p = 1005\text{J}/\text{kg}\cdot^\circ\text{C}$, $K_b = 0.6\text{W}/\text{m}\cdot^\circ\text{C}$, $h_{\text{air}} = 10\text{W}/\text{m}^2\cdot^\circ\text{C}$ and $H = 2538\text{kJ}/\text{kg}$.

Hence, by using equation (3-3):

$$U_w = \frac{1}{\frac{2}{h_{\text{air}}} + \frac{d_w}{K_b}} = 1.43\text{W}/\text{m}^2\cdot^\circ\text{C}$$

$$\text{Then } T_{\text{it}} = \frac{\rho_a \cdot V_i \cdot C_p}{U_w \cdot A_w} = 506.52, \quad k_{\text{it}} = \frac{1}{U_w \cdot A_w} = 0.028, \quad T_{\text{ih}} = \frac{V_i}{f} = 1500 \quad \text{and}$$

$$k_{\text{ih}} = \frac{1}{\rho_a \cdot f \cdot H} = 0.033$$

Therefore, the indoor temperature transfer function and indoor humidity transfer function can be expressed by two first order SISO system:

$$\frac{T_i(s)}{Q_{h1}(s)} = \frac{0.028}{506.52 \cdot s + 1} \quad (3-24)$$

$$\frac{H_i(s)}{Q_{h2}(s)} = \frac{0.033}{1500 \cdot s + 1} \quad (3-25)$$

The design of controllers for indoor temperature and humidity control are introduced and discussed in the following sections.

3.3 Fuzzy-based PID controller

An intelligent PID controller based on fuzzy logic controller (FLC) is designed for general purpose of indoor environment quality control including temperature, humidity and indoor air quality control in this research.

Fuzzy PID controllers can be used instead of linear PID controller in all classical or modern control system applications. They convert the error between the measured or controlled variable and the reference variable, into a command, which is applied to the actuator of a process. In practical design, it is important to have information about their equivalent input-output transfer characteristics. The main purpose of this research is to develop control systems for all kind of processes with a higher efficiency of the energy conversion and better values of the control quality criteria.

In this section, it introduces the structure and principle of the proposed fuzzy-PID strategy and then the controller design and control processes are described in detail. The fuzzy-PID controller is designed for temperature, humidity and indoor air quality in research. Hence, in this section of these factors: temperature is going to be used as the control signal to describe the controller.

3.3.1 Structure of fuzzy-PID controller

The self-tuning PID-type fuzzy controller contains two parts: a PID controller and a fuzzy logic controller (FLC) as shown in Figure 3-8. The proposed fuzzy-PID controller is an auto-adaptive controller that is designed by using an incremental fuzzy logic controller. The PID controller is used for the indoor climate control. The fuzzy logic controller is used for regulating the parameters of PID controller, k_p , k_i and k_d on-line by fuzzy logic control rules for better PID control performance in different situations.

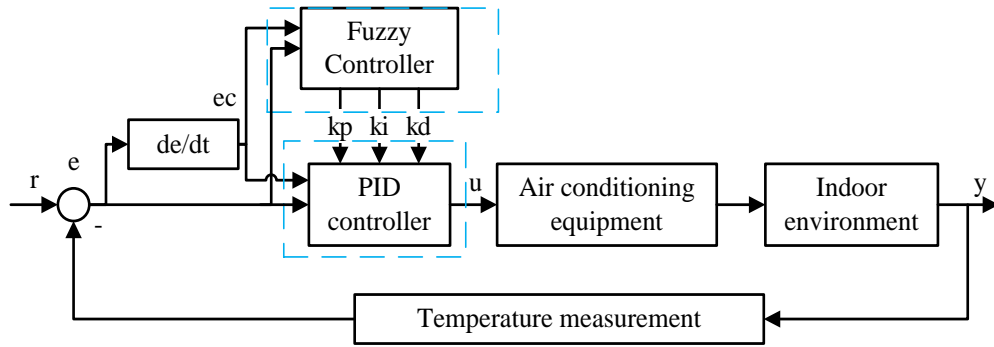

Figure 3-8 Structure of fuzzy-PID controller

Because the proposed fuzzy self-tuning PID controller aims to improve the control performance yielded by a PID controller, it keeps the simple structure of the PID controller and it is not necessary to modify any hardware parts of the original control system for implementation. The limitation for traditional control algorithm is largely made complete.

3.3.2 PID control algorithm

The indoor environment is controlled by a PID controller that uses the system error, e , and the changing rate of error, ec ; given by equation (3-26) and (3-27) as its inputs.

$e(k)$ is the error between the actual output and desire output and can be expressed as follows:

$$e(k) = r(k) - y(k) \quad (3-26)$$

$ec(k)$ is the changing rate of $e(k)$ and is given as:

$$ec(k) = e(k) - e(k-1) \quad (3-27)$$

The output of the PID controller is the work rate of heater and the system output is the indoor air temperature. The PID control algorithm can be expressed as follows:

$$u(k) = k_p (e(k) - e(k-1)) + k_i e(k) + k_d (e(k) - 2e(k-1) + e(k-2)) \quad (3-28)$$

The PID control performance mainly depends on the selection of the PID parameters, k_p , k_i and k_d . The Fuzzy block of the fuzzy-PID control strategy is design to auto-tune the values of the parameters.

3.3.3 Fuzzy block design

The function of the fuzzy logic controller is to tune the parameters of PID controller, k_p , k_i and k_d on-line by fuzzy logic control rules based on time-varying e and ec as shown in Figure 3-9 [244].

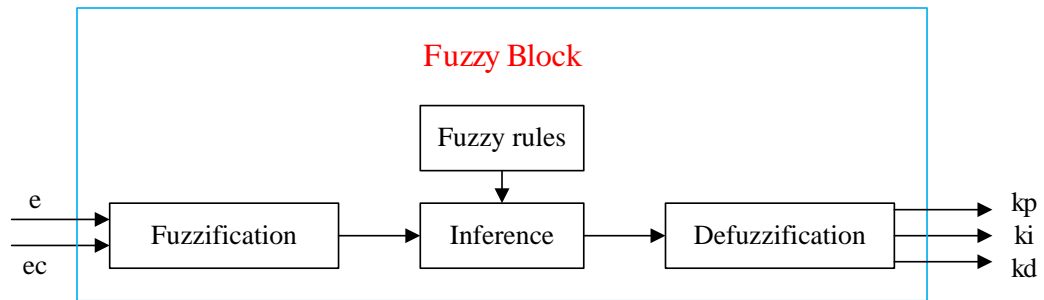

Figure 3-9 Scheme flow chart of the fuzzy block

Fuzzy self-tuning of PID parameters is to find out the fuzzy relation between three parameters of PID and e and ec . It measures the system output y and then calculates e and ec based on y and input r . Then the fuzzy controller tunes three parameters by fuzzy control rules on-line so that controlled objects achieve better dynamic steady performance. Hence, it is necessary to understand the function of each PID parameters. Then, it is possible to determine the relation between the fuzzy output, k_p , k_i and k_d and the fuzzy input, e and ec ; and finally to build the fuzzy rules. The functions of each PID parameter are discussed in Chapter 2 and how they affect the control performance and relate to the system error are listed in table 3-1 [171].

Table 3-1 Effects of k_p , k_i and k_d tuning

Closed-loop response	Rise time	Settling time	Overshoot	Steady-state error	stability
Increasing k_p	Decrease	Increase	Small increase	Decrease	Degrade
Increasing k_i	Small decrease	Increase	Increase	Large decrease	Degrade
Increasing k_d	Small decrease	Decrease	Decrease	Minor change	Improve

Table 3-2 Fuzzy rule base of k_p

Δk_p ec e	NB	NM	NS	ZO	PS	PM	PB
NB	PB	PB	PM	PM	PS	ZO	ZO
NM	PB	PB	PM	PS	PS	ZO	NS
NS	PM	PM	PM	PS	ZO	NS	NS
ZO	PM	PM	PS	ZO	NS	NM	NM
PS	PS	PS	ZO	NS	NS	NM	NM
PM	PS	ZO	NX	NM	NM	NM	NB
PB	ZO	ZO	NM	NM	NM	NB	NB

Then the fuzzy rule base is established based on the discussion of PID parameters effects as presented in Table 3-1. The fuzzy rule base contains three matrixes that how k_p , k_i and k_d will change (Δk_p , Δk_i and Δk_d) when e and ec varies as shown in table 3-1. The fuzzy rule base is constructed by using several if-then statements and premise and consequent of each statement which are fuzzy propositions. Table 3-2 –Table 3-4 indicates that 25 rules define the rule base for the fuzzy-PID type controller. The fuzzy variables are defined for the rule base as: e , ec , Δk_p , Δk_i and $\Delta k_d = \{NB \text{ (Negative Big), NM (Negative Medium), NS (Negative Small), ZO (Zero), PS (Positive Small), PM (Positive Medium), PB (Positive Big)}\}$.

Table 3-3 Fuzzy rule base of k_i

Δk_i / ec		NB	NM	NS	ZO	PS	PM	PB
e		NB	NM	NS	ZO	PS	PM	PB
NB		NB	NB	NM	NM	NS	ZO	ZO
NM		NB	NB	NM	NS	NS	ZO	ZO
NS		NB	NM	NS	NS	ZO	PS	PS
ZO		NM	NM	NS	ZO	PS	PM	PM
PS		NM	ND	ZO	PS	PS	PM	PB
PM		ZO	ZO	PS	PS	PM	PB	PB
PB		ZO	ZO	PS	PM	PM	PB	PB

Table 3-4 Fuzzy rule base of k_d

Δk_d / ec		NB	NM	NS	ZO	PS	PM	PB
e		NB	NM	NS	ZO	PS	PM	PB
NB		PS	NS	NB	NB	NB	NM	PS
NM		PS	NS	NB	NM	NM	NS	ZO
NS		ZO	NS	NM	NM	NS	NS	ZO
ZO		ZO	NS	NS	NS	NS	NS	ZO
PS		ZO	ZO	ZO	ZO	ZO	ZO	ZO
PM		PB	NS	PS	PS	PS	PS	PB
PB		PB	PM	PM	PM	PS	PS	PB

Once rule base has been defined, the membership functions for e , ec , Δk_p , Δk_i and Δk_d are needed to be determined as shown in Figure 3-10 – Figure 3-14. A membership function is a curve that defines how each point in the input space is mapped to a membership value (on degree of membership) between 0 and 1 [234]. In this case, the combined triangular and gauss membership functions are used for all variables. The physical domain [234] of e and ec is $\{-3, -2, -1, 0, 1, 2, 3, \}$; the physical domain of Δk_p is $\{-0.3, -0.2, -0.1, 0, 0.1, 0.2, 0.3\}$; the physical domain of Δk_i is $\{-0.06, -0.04, -0.02, 0, 0.02, 0.04, 0.06\}$ and that of the Δk_d is $\{-4, -3, -2, -1, 0, 1, 2, 3, 4\}$.

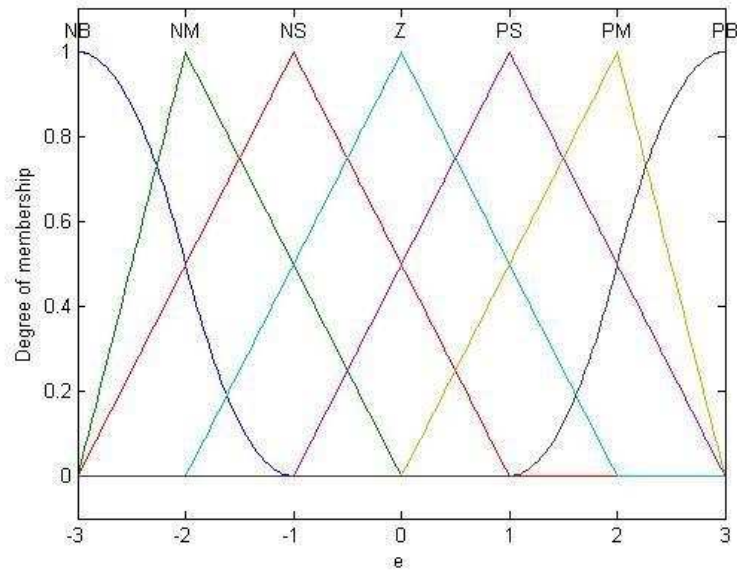

Figure 3-10 Membership function of system error

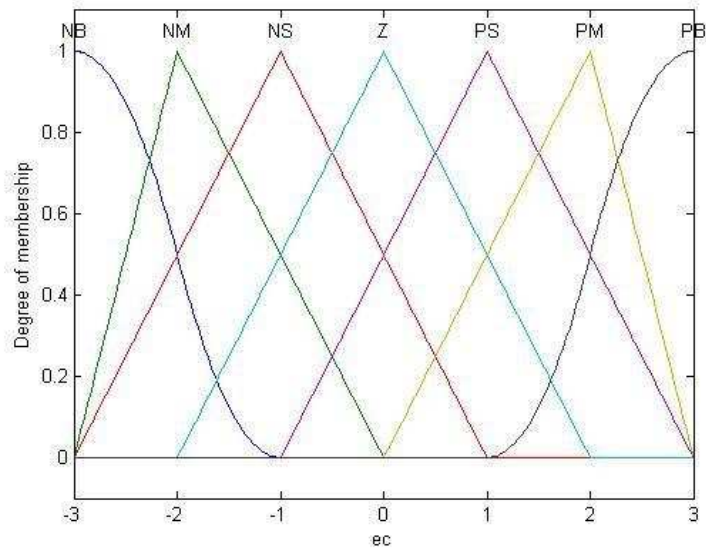

Figure 3-11 Membership function of system error changing rate

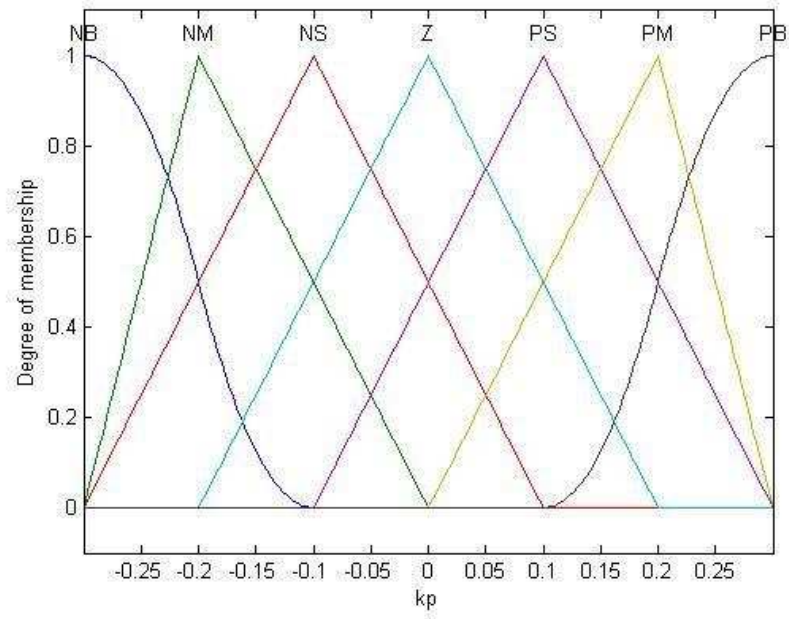

Figure 3-12 Membership function of k_p

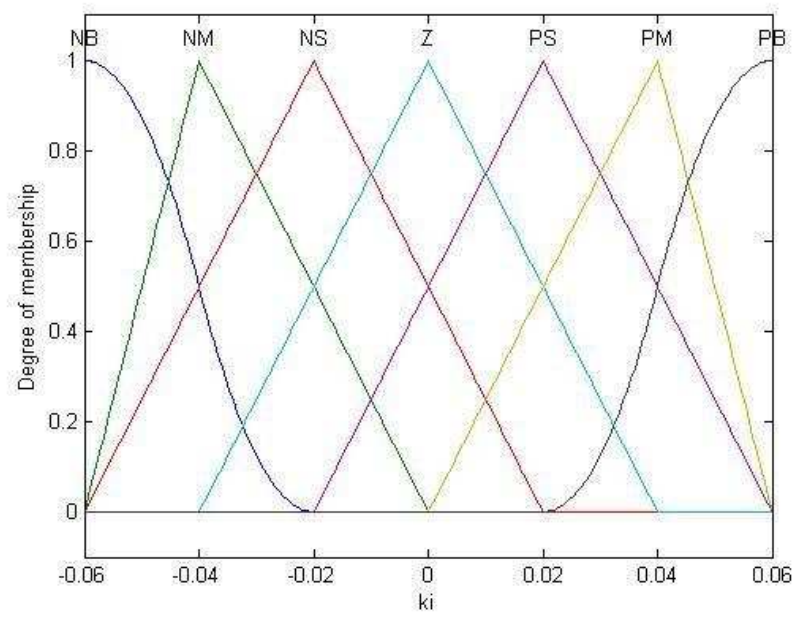

Figure 3-13 Membership function of k_i

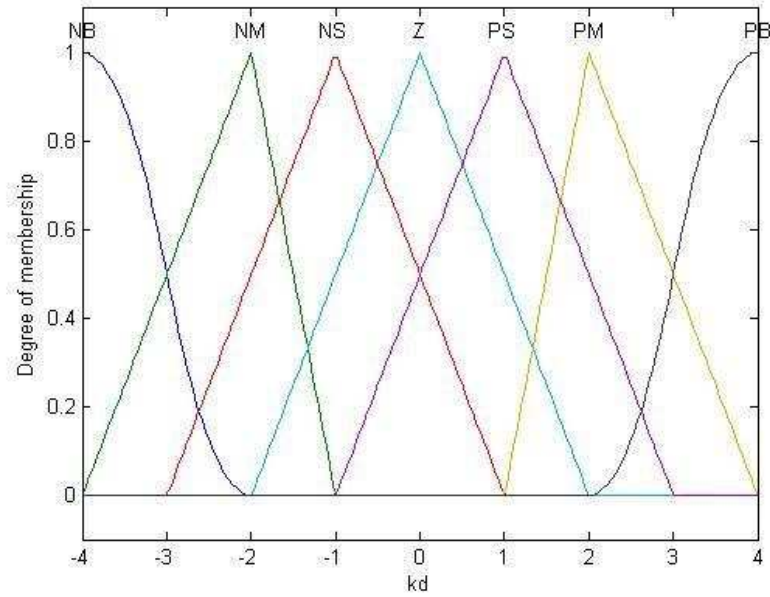

Figure 3-14 Membership function of k_d

Since we can get the $\Delta k_p, \Delta k_i$ and Δk_d value based on fuzzy rule base and function membership. Then, the k_p, k_i and k_d can be calculated by using the following equations:

$$k_p(k+1) = f_{k_p}(e, ec) = k_p'(k) + \Delta k_p(k) \quad (3-29)$$

$$k_i(k+1) = f_{k_i}(e, ec) = k_i'(k) + \Delta k_i(k) \quad (3-30)$$

$$k_d(k+1) = f_{k_d}(e, ec) = k_d'(k) + \Delta k_d(k) \quad (3-31)$$

The desired k_p, k_i and k_d values can be gotten by using the FLC, and transferred to the PID controller in order to operate the air-conditioning equipments properly and obtain an comfortable indoor environment.

3.3.4 Summary of fuzzy-PID control

The control process of the fuzzy-PID controller can be summarised as follows as shown in Figure 3-15:

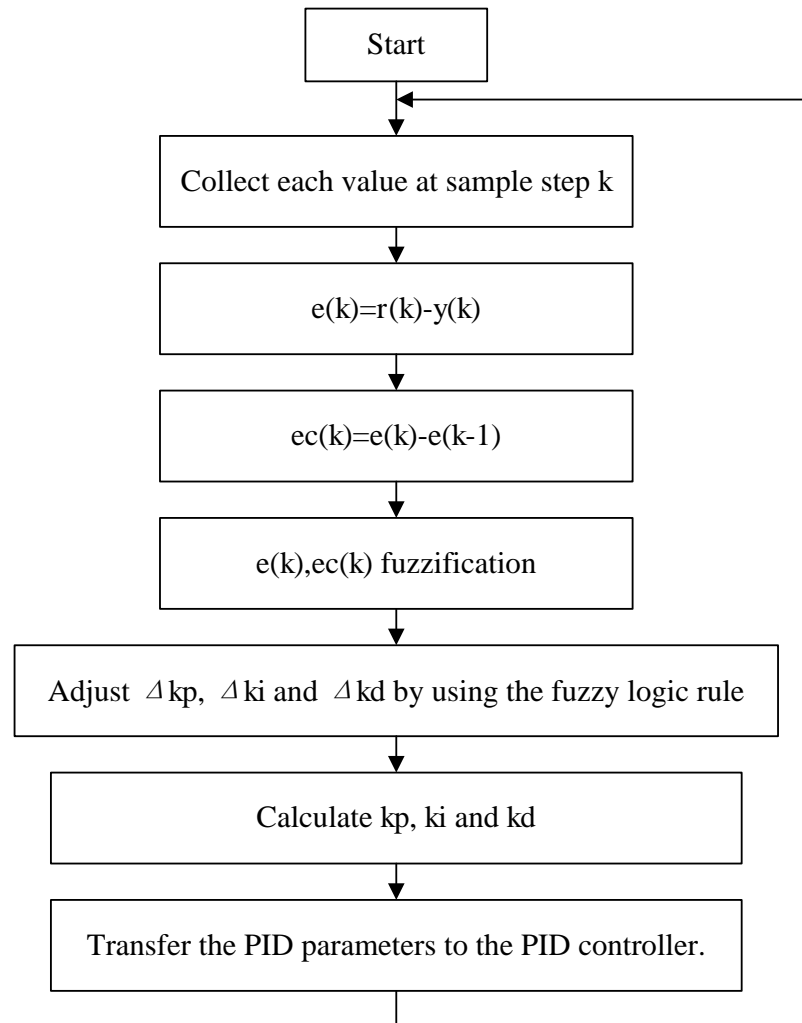

Figure 3-15 Flow chart of fuzzy-PID controller

- Collect control data at sample step k by using measurement equipment.
- Calculate the system error and changing rate of the system error by using equation (3-26) and (3-27).
- Fuzzification of e and ec by using the membership function as presented in Figure 3-10 and Figure 3-11.
- Get the fuzzy values of Δk_p , Δk_i and Δk_d by using the fuzzy rule bases as shown in Table 3-3 – Table 3-4.

- Defuzzification of Δk_p , Δk_i and Δk_d by using membership function Figure 3-12 – Figure 3-14.
- Calculate k_p , k_i and k_d by using equation (3-29) – (3-31).
- k_p , k_i and k_d are provided to PID controller for indoor temperature control.

The control performance of the proposed fuzzy-PID control strategy is verified by simulating tests using Matlab in Chapter 4 and investigated by experiments in Chapter 5.

3.4 RBFNN- PID controller

Although a fuzzy PID control is designed for general indoor climate control, temperature, humidity and indoor air quality are different physical quantities and have different features. Hence, in order to further analyse potential of using advanced control method to improve the indoor environment quality, research work should be carried out and a novel control strategy for indoor humidity is designed based on the humidity control difficulties in this section.

The major difficulties of indoor humidity control include:

- time delay,
- preference of deferent people.
- influence caused by temperature.

Hence, the designed controller has the following requirement: quick response, small overshoot, good adaptability and intelligent algorithm to tell whether the temperature is hot, cold warm or else. An intelligent PID controller based on Radial Basis Function (RBF) neural network is introduced for indoor temperature control in this section. In this research, the performance of the RBFNN-PID controller is verified by the computer simulation using Matlab as introduced in Section 4.2. The experimental

test of this controller will be carried out in laboratory in further work as discussed in Section 6.3.

3.4.1 Structure of RBFNN based PID controller

A novel intelligent PID control strategy based on RBFNN algorithm is designed for indoor humidity control in this project as shown in Figure 3-16. It presents the structure of the RBFNN-PID controller that includes two main parts: a PID controller used for indoor humidity control and a RBF neural network used for regulating PID parameters: k_p , k_i and k_d .

PID controllers have been widely used for indoor environment control because of its practicality and good control performance and the PID controller is selected as the main part of the proposed control strategy for the indoor humidity control. The RBF neural network is used for regulating the PID parameters automatically; and it will shorten the time cost of designing the controller and will increase the controller's adaptability. Hence, the principle of the novel control strategy is to combine the advantages of the conventional control method (PID controller in this control strategy) and advanced control technique (radial basis function neural network).

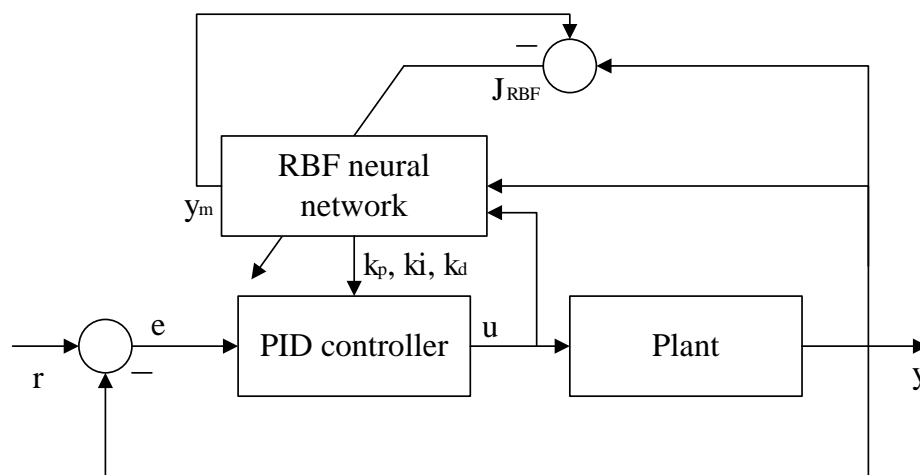

Figure 3-16 RBFNN based PID controller

3.4.2 RBFNN algorithm for k_p , k_i , k_d regulation

A radial basis function (RBF) network is a three layer feed forward artificial neural network that uses radial basis functions as activation functions. The output of the network is a linear combination of radial basis functions of the inputs and neuron parameters. Radial basis function networks have many uses, including function approximation, time series prediction, classification, and system control. It has the advantage of fast learning speed and is able to avoid the problem of local minimum in system control field. Hence the RBFNN is used for tuning the PID parameters in the control strategy.

The Jacobian generalizes the gradient of a scalar-valued function of multiple variables, which itself generalizes the derivative of a scalar-valued function of a single variable. In other words, the Jacobian for a scalar-valued multivariable function is the gradient and that of a scalar-valued function of single variable is simply its derivative. The Jacobian can also be thought of as describing the amount of "stretching", "rotating" or "transforming" that a transformation imposes locally [286]. Moreover, the Jacobian matrix is important for regulating the PID parameters in this control strategy.

The designed RBF network has three layers: an input layer, a single hidden layer and an output layer as shown in Figure 3-17. There are two inputs in this network and the input vector of the RBF network is given as:

$$\mathbf{X} = [x_1, \dots, x_i]^T = [u, y]^T \quad \{i=1,2\} \quad (3-32)$$

where u is the output of PID humidity controller, humidifier's work power and y is the system output, the indoor air humidity level and i is the number of the neurons in input layer.

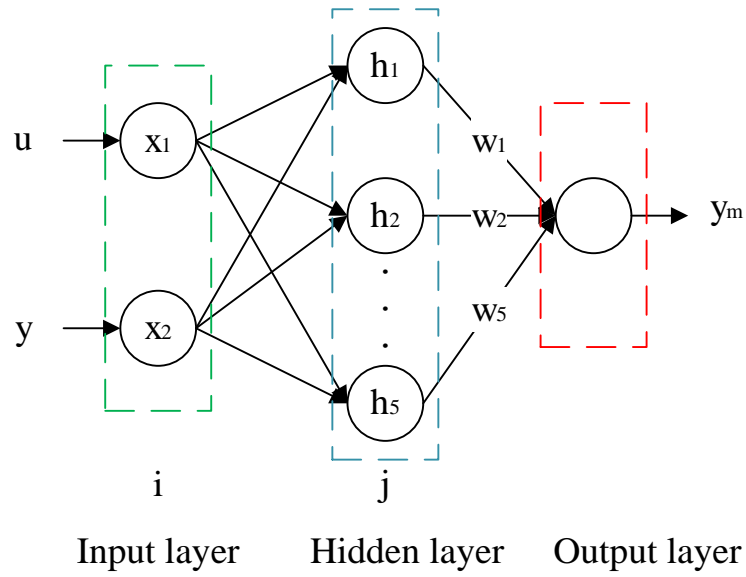

Figure 3-17 The RBF neural network

In a RBF neural network, the Gaussian function is used as the activation function. The hidden neurons implement Gaussian function as the basis function and the elements of radial basis vector $H = [h_1, h_2, \dots, h_j, \dots, h_5]^T$ can be expressed by Gaussian function as follows:

$$h_j = e^{-\frac{\|x - c_j\|^2}{2b_j^2}} \quad \{ j = 1, 2, \dots, 5 \} \quad (3-33)$$

where X is the input vector of the neural network as given by equation (3-32), $C_j = [c_{j1}, c_{j2}]$ is the input vector of the j th node in the hidden layer, b_j is the width parameter of the j th node in hidden layer and j is the number of neurons in hidden layer.

Thus the network output can be express as follows:

$$y_m(k) = w_1 h_1 + \dots + w_j h_j + \dots + w_5 h_5 \quad (3-34)$$

where w_j is the weight from hidden layer to output layer.

Then the performance index function of the neural network is defined as follows:

$$J_{\text{RDF}} = y(k) - y_m(k) \quad (3-35)$$

where $y(k)$ is the system output at sample step k and $y_m(k)$ is the network output.

As shown in Figure 3-16, the J_{RDF} is used to adjust the weights of the neural network. The weight of each neuron in network is adjusted based on the gradient descent algorithm and the equation is given by:

$$w_j(k) = w_j(k-1) + \eta \cdot J_{\text{RDF}} \cdot h_j + \alpha(w_j(k-1) - w_j(k-2)) \quad (3-36)$$

where η is learning rate, α is momentum factor.

The basis width parameter of each node in network can be adjusted based on the gradient descent algorithm by using the following equation:

$$b_j(k) = b_j(k-1) + \eta \Delta b_j + \alpha(b_j(k-1) - b_j(k-2)) \quad (3-37)$$

where Δb_j is the change of the basis width parameter and can be expressed as follows:

$$\Delta b_j = J_{\text{RDF}} \cdot w_j \cdot h_j \frac{\|X - C_j\|^2}{b_j^3} \quad (3-38)$$

Then, the change of the hidden layer's input vector can be calculated based on the gradient descent algorithm as follows:

$$\Delta c_{ji} = J_{\text{RDF}} \cdot w_j \frac{x_j - c_{ji}}{b_j^2} \quad (3-39)$$

And the adjustment rule of the hidden layer's input vector can be expressed as

follows:

$$c_{ji}(k) = c_{ji}(k-1) + \eta \Delta c_{ji} + \alpha (c_{ji}(k-1) - c_{ji}(k-2)) \quad (3-40)$$

Thus, the Jacobian matrix can be gotten based on the previous calculation:

$$\frac{\partial y(k)}{\partial u(k)} = \sum w_j h_j \frac{c_{ji}(k) - u(k)}{b_j(k)^2} \quad (3-41)$$

It has been known that the PID control performance is based on the value of PID parameters k_p , k_i and k_d . The PID controller can have excellent performance with proper parameters, otherwise the controller cannot achieve desired control requirement. Thus, the regulating the PID parameters properly is an important task and the designed RBF network is able to tune k_p , k_i and k_d accurately in different situations by using the Jacobian matrix.

Firstly, the error function of the network is defined as:

$$E(k) = \frac{1}{2} (r(k) - y(k))^2 \quad (3-42)$$

Then, the k_p , k_i and k_d auto-tuning rule is designed based on the gradient descent iteration method as follows:

$$\Delta k_p = -\eta \frac{\partial E}{\partial k_p} = -\eta \frac{\partial E}{\partial y} \cdot \frac{\partial y}{\partial u} \cdot \frac{\partial u}{\partial k_p} = \eta \cdot e(k) \frac{\partial y}{\partial u} \cdot xc_1(k) \quad (3-43)$$

$$\Delta k_i = -\eta \frac{\partial E}{\partial k_i} = -\eta \frac{\partial E}{\partial y} \cdot \frac{\partial y}{\partial u} \cdot \frac{\partial u}{\partial k_i} = \eta \cdot e(k) \frac{\partial y}{\partial u} \cdot xc_2(k) \quad (3-44)$$

$$\Delta k_d = -\eta \frac{\partial E}{\partial k_d} = -\eta \frac{\partial E}{\partial y} \cdot \frac{\partial y}{\partial u} \cdot \frac{\partial u}{\partial k_d} = \eta \cdot e(k) \frac{\partial y}{\partial u} \cdot xc_3(k) \quad (3-45)$$

where $\frac{\partial y}{\partial u}$ is the Jacobian matrix given by equation (3-41). $xc_1(k)$, $xc_2(k)$ and

$xc_3(k)$ are the inputs of the PID controller in this control strategy and their calculation will be given in the following section.

Therefore, the optimum PID parameters can be gained and then provided to the PID controller in order to get the desired control performance. And the PID control algorithm in this control strategy is introduced in the following section.

3.4.3 PID control algorithm

In this control strategy, the system error between the system desired output and the system actual output as shown in Figure 3-16 is given by:

$$e(k) = r(k) - y(k) \quad (3-46)$$

The PID inputs can be expressed as follows:

$$xc_1(k) = e(k) - e(k-1) \quad (3-47)$$

$$xc_2(k) = e(k) \quad (3-48)$$

$$xc_3(k) = e(k) - 2e(k-1) + e(k-2) \quad (3-49)$$

Then the PID control algorithm is given as:

$$u(k) = u(k-1) + k_p(e(k) - e(k-1)) + k_i e(k) + k_d(e(k) - 2e(k-1) + e(k-2)) \quad (3-50)$$

3.4.4 Summary of RBFNN based PID control

So the control process of the RBFNN-PID control as presented in Figure 3-18 can be summarised as follows:

- collect each value at sampling step k
- calculate the network output y_m based on the collected data

- get the Jacobian matrix using the give equations
- tune the PID parameters for the PID controller
- controller send command to the HVAC equipment for humidity control and since the indoor climate may change the control process should be carried on
- set $k=k+1$

The control performance of the proposed RBFNN-PID control strategy for indoor humidity is verified by simulating tests using Matlab in Chapter 4.

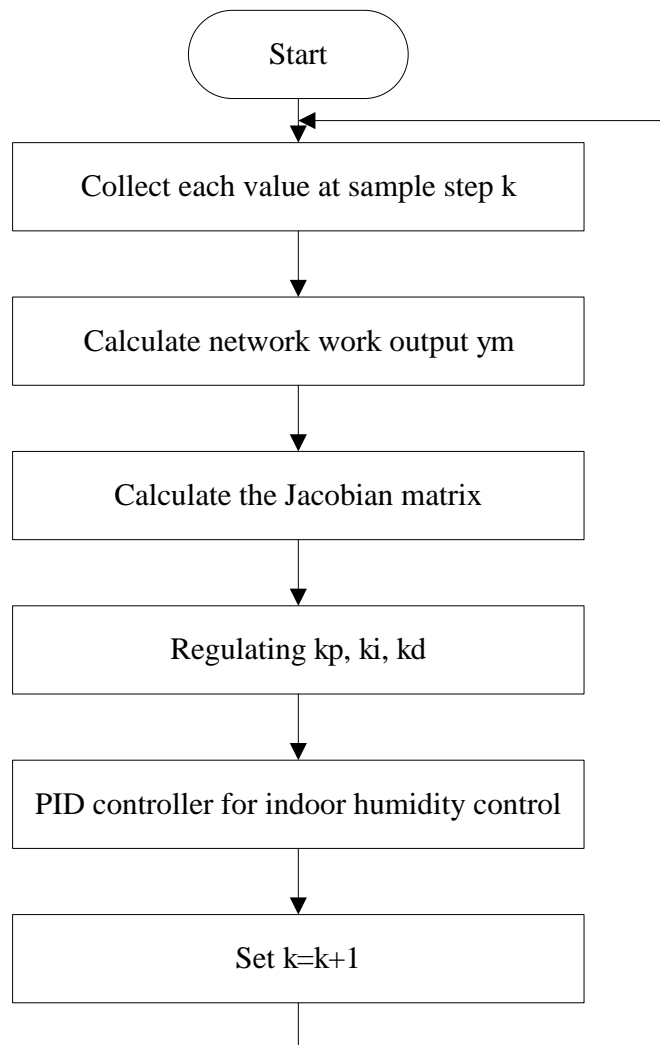

Figure 3-18 Flow chart of RBFNN-PID controller

3.5 BPNN-based PID controller

As investigating all types of indoor air pollutants for general air quality monitoring and control is a complicated matter [70-71], it was suggested that the measurement and analysis of indoor carbon dioxide (CO₂) concentration could be useful for understanding IAQ and ventilation effectiveness [72-74]. The difficulty in IAQ control is the time delay and measurement errors. In order to achieve an optimal system performance in terms of response speed, systemic stability, disturbance resistance and small overshoot, a neural network proportional-integral-derivative (PID) controller with back-propagation based weight updating algorithm is proposed. The structure and algorithm of the BPNN-PID control is introduced in this section. The performance of the BPNN-PID controller is tested by computer simulation using Matlab code as discussed in Section 4.3. The experimental test of the BPNN-PID control will be carried out in future work as introduced in Section 6.3.

3.5.1 Structure of the BPNN-PID controller

Figure 3-19 presents the structure of the proposed intelligent PID controller based on BPNN learning algorithm. It contains two parts: 1) a classic PID controller and 2) BPNN. The PID controller is used to control the control object (indoor air quality in building environment). The control performance depends on the setting of PID control parameters k_p , k_i and k_d which can be auto tuned by the BPNN. The BPNN uses an on-line training algorithm based on a gradient descent approach to update network weights and ensures that the designed neural network is able to calculate the desired PID control parameters for the PID controller. Therefore, in this control approach, by combining the classic PID control and the intelligent BPNN the targeted system output can be tracked with a guaranteed stability.

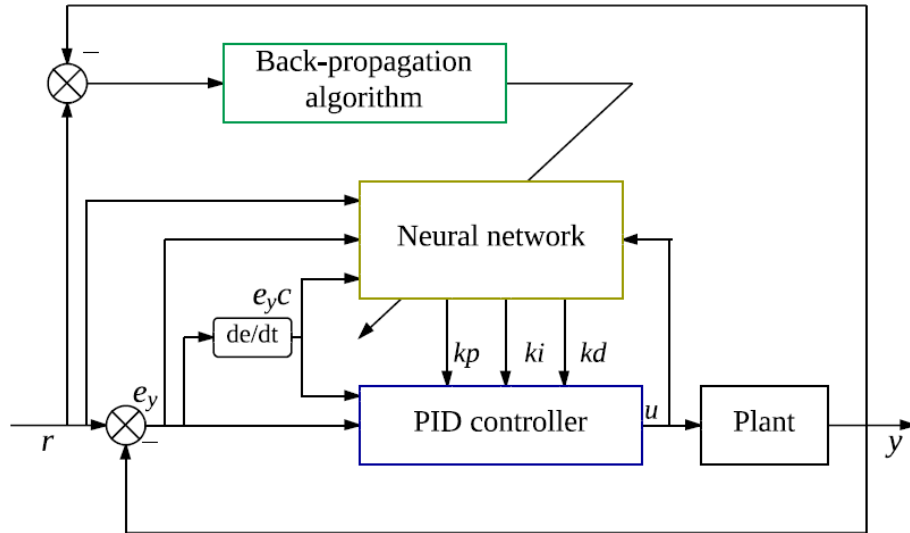

Figure 3-19 BPNN based PID control scheme

3.5.2 PID control algorithm

The incremental digital PID control algorithm can be expressed as follows:

$$u(k) = u(k-1) + k_p \{error(k) - error(k-1)\} + k_i error(k) + k_d \{error(k) - 2error(k-1) + error(k-2)\} \quad (3-51)$$

where u is the output of the PID controller, k_p is the proportional term, k_i is the integral term, k_d is the derivative term and e_y is the system error that can be expressed as follows:

$$e_y(k) = y(k) - r(k) \quad (3-52)$$

where y is the system actual output and r is the system targeted output.

3.5.3 BPNN algorithm

If the neural network has sufficient amount of neurons, it is able to approximate any continuous function with only one hidden layer [304–307]. Therefore, a neural network with only one hidden layer is designed. As shown in Figure 3-20, the proposed design is a four-input-three-output BPNN with three layers: input layer, one

single hidden layer and output layer. In this section, the forward feed algorithm and the back-propagation weights adjustment rule is discussed in detail.

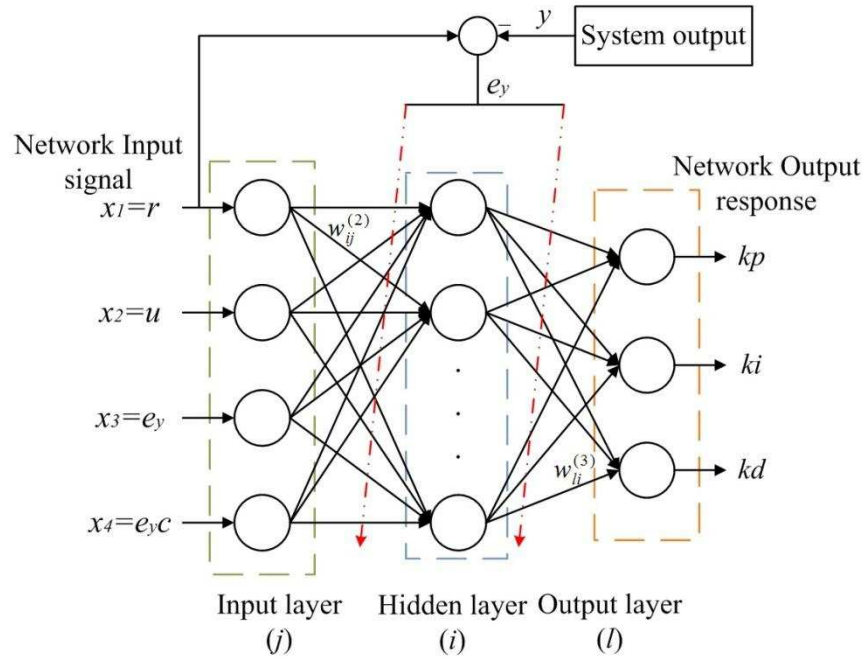

Figure 3-20 BPNN algorithm scheme

(1) Feed forward control

The designed neural network has four inputs as shown in both Figure 3-19 and Figure 3-20 and they are:

$$\begin{Bmatrix} x_1 \\ x_2 \\ x_3 \\ x_4 \end{Bmatrix} = \begin{Bmatrix} r \\ u \\ e_y \\ e_y c \end{Bmatrix} \quad (3-53)$$

where r , u and e_y is defined in equations (3-51) and (3-52); and $e_y c$ is the changing rate of system error e_y that can be expressed as follows:

$$e_y c(k) = e_y(k) - e_y(k-1) \quad (3-54)$$

Output of each neuron in the input layer is expressed as:

$$O_j^{(1)} = x(j) \quad \{j = 1,2,3,4\} \quad (3-55)$$

In the designed algorithm, superscript (1) stands for input layer.

Input of each neuron in the neural network hidden layer can be calculated based on the input layer output and is expressed as follows:

$$\text{in}_i^{(2)}(k) = \sum_{j=1}^4 w_{ij}^{(2)} O_j^{(1)} \quad \{i = 1,2,\dots, N\} \quad (3-56)$$

where superscript (2) stands for hidden layer; $w_{ij}^{(2)}$ is the weight connecting the input layer neurons to the hidden layer neurons and N is the number of neurons in the hidden layer.

Then, output of each neuron in the neural network hidden layer can be expressed as follows:

$$O_i^{(2)}(k) = f(\text{in}_i^{(2)}(k)) \quad (3-57)$$

where $f(x)$ is the activation function in the hidden layer that presents the relation between the input and output of each neuron. Symmetrical Sigmoid function is used as the activation function and can be expressed as follows:

$$f(x) = \tanh(x) = \frac{e^x - e^{-x}}{e^x + e^{-x}} \quad (3-58)$$

Once the output of each neuron in hidden layer is calculated, the input of each neuron in the output layer can be given as:

$$\text{in}_l^{(3)}(k) = \sum_{i=1}^N w_{li}^{(3)} O_i^{(2)}(k) \quad \{l = 1,2,3\} \quad (3-59)$$

where superscript (3) stands output layer; $w_{li}^{(3)}$ is the weight connecting the hidden layer neurons to the output layer neurons.

The number of neurons in output layer is three and the outputs of the neurons are the PID parameters. Output of each neuron in the output layer is given by:

$$O_1^{(3)}(k) = g(\text{in}_1^{(3)}(k)) \quad (3-60)$$

$$O_1^{(3)}(k) = k_p \quad (3-73)$$

$$O_2^{(3)}(k) = k_i \quad (3-62)$$

$$O_3^{(3)}(k) = k_d \quad (3-63)$$

where $g(x)$ is the activation function that presents the relation between the input and output of each neuron in the output layer. Outputs of the output layer are the PID parameters k_p , k_i and k_d . Since these values cannot be negative, the non-negative Sigmoid function is used as the activation function in output layer and it is given as:

$$g(x) = \frac{1}{2}(1 + \tanh(x)) = \frac{e^x}{e^x + e^{-x}} \quad (3-64)$$

The proposed neural network can regulate the PID control parameters automatically and it can reduce sufficient time cost for engineers in control system design process. However, modelling errors often exist in model based process control and dramatically increase the difficulty to accurately control the process. Therefore, an on-line training algorithm is applied to adjust network weights for reducing the system error e_y in the design of the BPNN controller.

(2) Weight update

In this algorithm, the system output error function is defined by the given equation (3-65):

$$E_y(k) = \frac{1}{2}(r(k) - y(k))^2 = \frac{1}{2}e \quad (3-65)$$

The training process of the neural network model must be carried out before it can be put into use. This training process is repeated until the mean square error of the training data reaches the desired minimum. In the present work, the training process is based on back propagation. The basic idea of back propagation is to adjust the neuron weights using gradient descent algorithm on the error function in an iteration process. Generally, the adjustment of each weight from hidden-layer to output-layer can be expressed as follows:

$$\Delta w_{ii}^{(3)}(k) = -\eta \frac{\partial E_y(k)}{\partial w_{ii}^{(3)}} \quad (3-66)$$

However, in order to avoid the ‘local minima’ which is the best known problem associated with back-propagation algorithm; a momentum term is added to the weight change in the proposed algorithm. This means that the weight change this iteration depends not just on the current error, but also on previous changes. So the adjustment of each weight from hidden-layer to output-layer is modified as follows based on the system output error function as shown in Figure 3-21:

$$\Delta w_{ii}^{(3)}(k) = -\eta \frac{\partial E_y(k)}{\partial w_{ii}^{(3)}} + \alpha \Delta w_{ii}^{(3)}(k-1) \quad (3-67)$$

where is η learning rate, α is momentum factor.

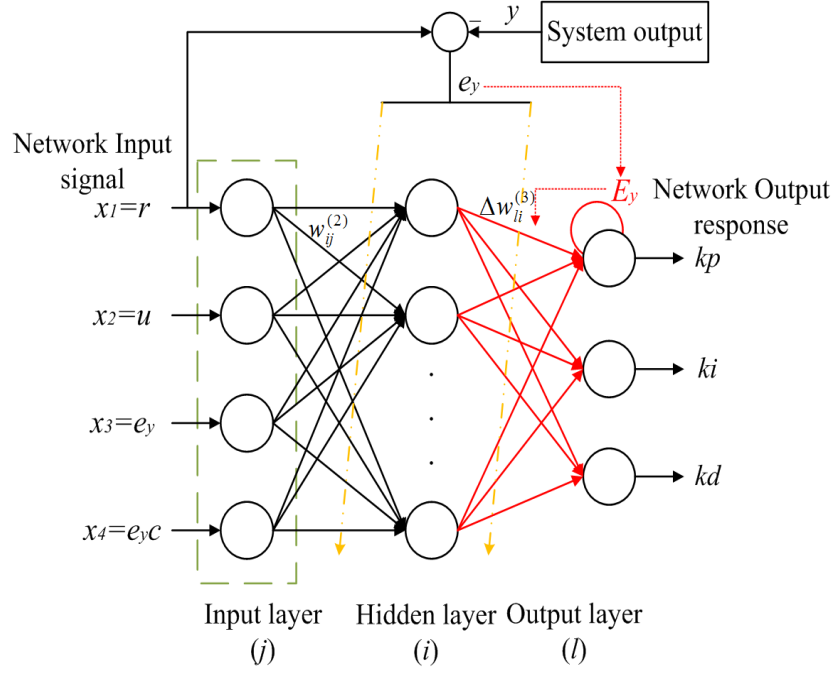

Figure 3-21 Adjustment of weight from hidden layer to output layer

Since

$$\frac{\partial E_y(\mathbf{k})}{\partial w_{ii}^{(3)}(\mathbf{k})} = \frac{\partial E_y(\mathbf{k})}{\partial y(\mathbf{k})} \cdot \frac{\partial y(\mathbf{k})}{\partial u(\mathbf{k})} \cdot \frac{\partial u(\mathbf{k})}{\partial O_1^{(3)}(\mathbf{k})} \cdot \frac{\partial O_1^{(3)}(\mathbf{k})}{\partial \text{in}_1^{(3)}(\mathbf{k})} \cdot \frac{\partial \text{in}_1^{(3)}(\mathbf{k})}{\partial w_{ii}^{(3)}(\mathbf{k})} \quad (3-68)$$

$$\frac{\partial \text{in}_1^{(3)}(\mathbf{k})}{\partial w_{ii}^{(3)}(\mathbf{k})} = O_i^{(2)}(\mathbf{k}) \quad (3-69)$$

and based on equation (63), (73), (74) and (75), the following equations are calculated:

$$\frac{\partial u(\mathbf{k})}{\partial O_1^{(3)}(\mathbf{k})} = e_y(\mathbf{k}) - e_y(\mathbf{k}-1) \quad (3-70)$$

$$\frac{\partial u(\mathbf{k})}{\partial O_2^{(3)}(\mathbf{k})} = e_y(\mathbf{k}) \quad (3-71)$$

$$\frac{\partial u(\mathbf{k})}{\partial O_3^{(3)}(\mathbf{k})} = e_y(\mathbf{k}) - 2e_y(\mathbf{k}-1) + e_y(\mathbf{k}-2) \quad (3-72)$$

Then, the learning algorithm of the weight update in output layer can be expressed as follows:

$$w_{ii}^{(3)}(k+1) = w_{ii}^{(3)}(k) + \Delta w_{ii}^{(3)}(k) \quad (3-73)$$

$$\Delta w_{ii}^{(3)}(k) = \alpha \Delta w_{ii}^{(3)}(k-1) + \eta \delta_1^{(3)} O_1^{(2)}(k) \quad (3-74)$$

where $\delta_1^{(3)}$ is the error function of the network hidden layer that is need for the adjustment of weights from input layer to hidden layer as shown in Figure 3-22. $\delta_1^{(3)}$ can be expressed as follows:

$$\delta_1^{(3)} = e_y(k) \cdot \frac{\partial y(k)}{\partial u(k)} \cdot \frac{\partial u(k)}{\partial O_1^{(3)}(k)} \cdot g'(\text{in}_1^{(3)}(k)) \quad (3-75)$$

where the first derivative of $g(x)$ is given by:

$$g'(x) = g(x)(1 - g(x)) \quad (3-76)$$

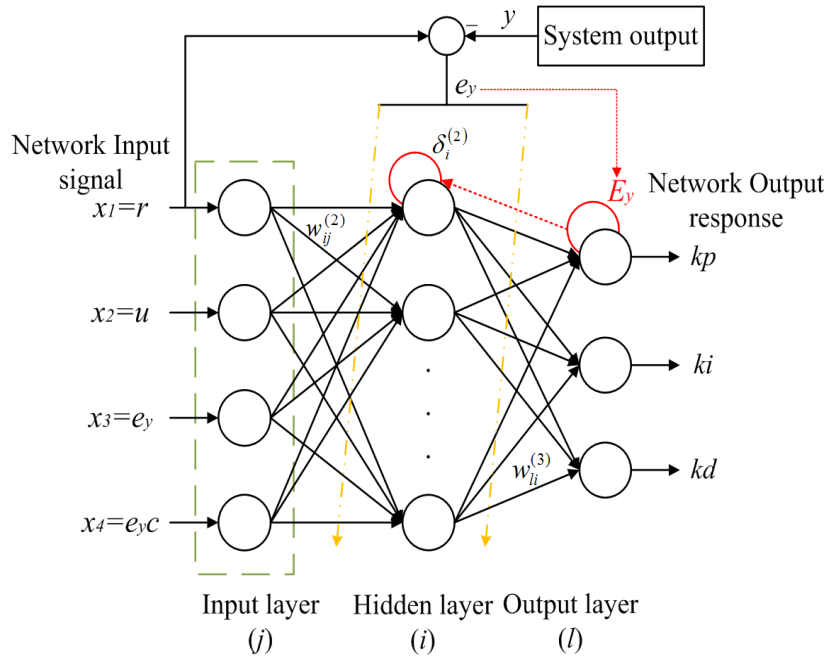

Figure 3-22 Error function of the network hidden layer

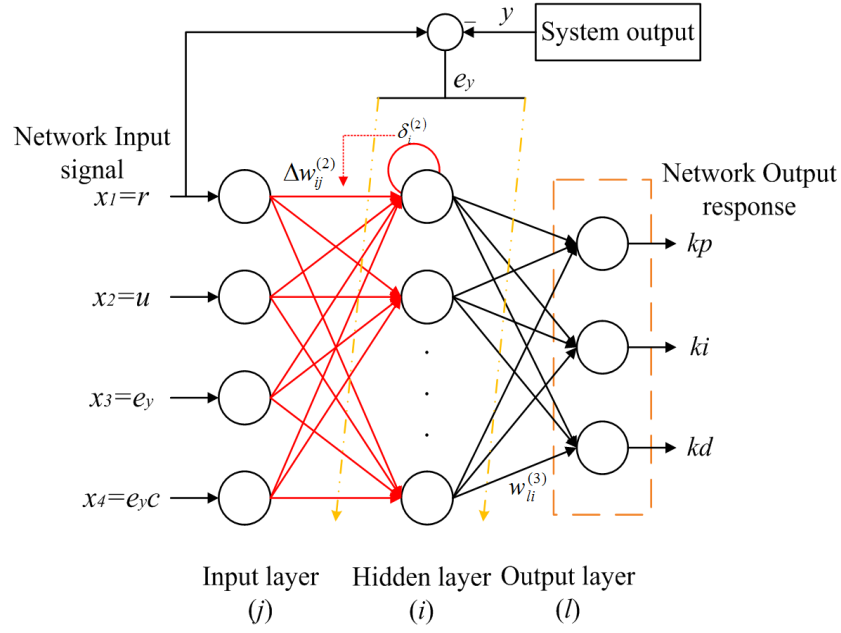

Figure 3-23 Adjustment of weight from input layer to hidden layer

Then, using the similar calculation and the weight update in hidden layer is calculated based on gradient descent algorithm and the hidden layer error function as show in Figure 3-23. The learning algorithm can be expressed by as follows:

$$w_{ij}^{(2)}(k+1) = w_{ij}^{(2)}(k) + \Delta w_{ij}^{(2)}(k) \quad (3-77)$$

$$\Delta w_{ij}^{(2)}(k) = \alpha \Delta w_{ij}^{(2)}(k-1) + \eta \delta_i^{(2)} O_j^{(1)}(k) \quad (3-78)$$

$$\delta_i^{(2)} = f'(\text{in}_i^{(2)}(k)) \cdot \sum_{l=1}^3 \delta_l^{(3)} w_{li}^{(3)}(k) \quad (3-79)$$

Where the first derivative of $f(x)$ is given by:

$$f'(x) = \frac{(1 - f^2(x))}{2} \quad (3-80)$$

3.5.4 Summary of the BPNN-PID control strategy

In the control process, the weights in the neural network are trained by the back-propagation weights adjustment rule in order to obtain the best PID parameters

k_p , k_i and k_d for the PID controller. Therefore, an acceptable indoor air quality can be provided by the control of designed system. The algorithm of the BPNN based PID can be summarised as follows and its flowchart is presented in Figure 3-24:

- 1) Initialize the each weight in the neural network $w_{ij}^{(2)}(k)$ and $w_{li}^{(3)}(k)$, as well as learning rate η and momentum factor α while $k=1$.
- 2) Collect data $r(k)$ and $y(k)$ and calculate the system error e_y using equation (2).
- 3) Calculate the input and output of each neuron and get the PID parameters k_p , k_i and k_d .
- 4) Calculate the output of PID controller using equation (1).
- 5) On-line training. Adjust the weight of each neuron in the neural network with the back-propagation learning algorithm in order to realize self-adaptive regulation of the PID parameters k_p , k_i and k_d .
- 6) Set $k=k+1$ and go back to rule 1).

The control performance of the proposed BPNN-PID control strategy for indoor air quality is verified by simulating tests using Matlab in Chapter 4.

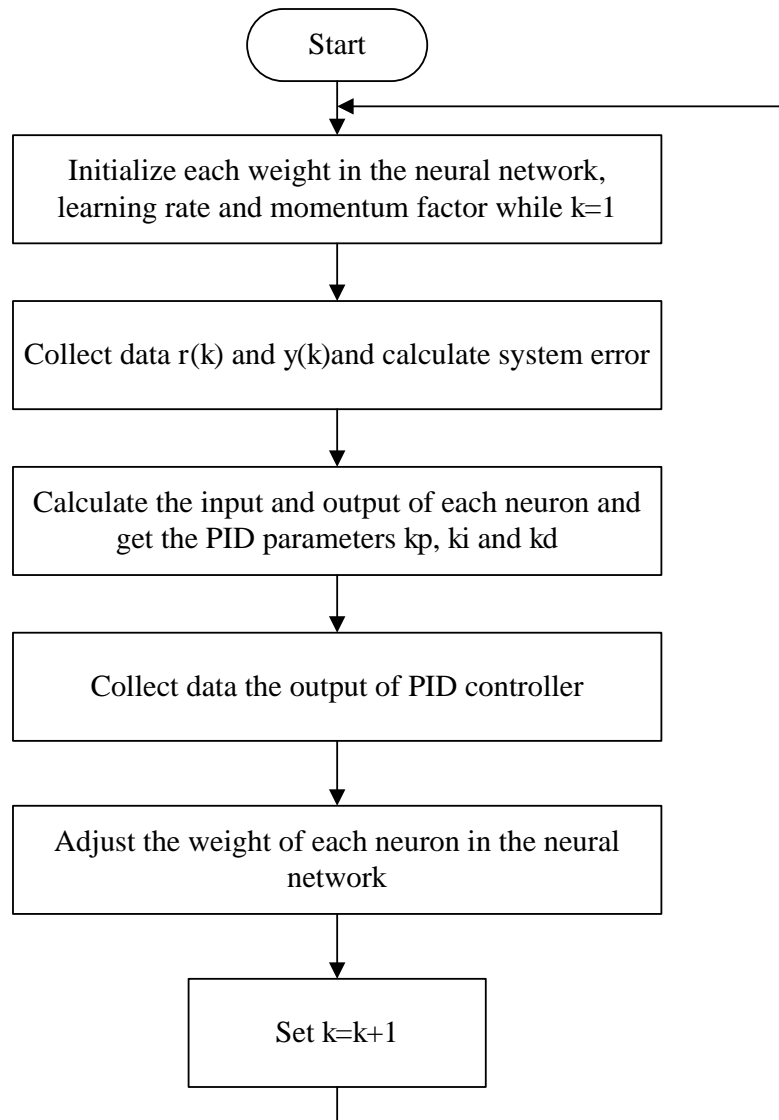

Figure 3-24 Flow chart of BPNN-PID control scheme

3.6 Summary

As indoor environment has significant affected occupants' health, people's productivity and feeling of comfort, all important factors of indoor climate quality including indoor temperature, indoor humidity and indoor air quality should be well controlled for increasing demand of living standard. However, major difficulties exist that limit the development of control technologies for indoor environment quality control including:

- Difficult to predict the system response, and to employ appropriate comfort indices to search for the optimal set point(s) according to the system responses.
- Complex HVAC systems are hard to be analysed and controlled.
- Time delay.
- Disturbances always exist in control process in both thermal comfort control and indoor air quality control. For example, opening the window or door may cause the indoor temperature and humidity change; people entering the room may cause the CO₂ concentration increasing.
- HVAC systems always response lag behind the indoor environment change.
- The existence of mismeasurement of control signal value is considered as one of the major problems of indoor air quality.
- The fact that control signals sometimes depend on each other makes the steady state of control performance unstable.

Hence, in order to solve these problems, in this chapter three newly designed intelligent controllers: fuzzy PID controller for indoor temperature control, radial basis function neural network PID controller for indoor humidity control and back-propagation neural network PID controller for indoor air quality control. The designs of these controllers including control structures and control algorithms are discussed in detail. In this section, it summarises the design of each controller and theoretically analyses their potential advantages for indoor environment quality control.

Fuzzy-PID

Based on the difficulties of indoor climate control as summarised in Chapter 2 a fuzzy-PID controller was designed to solve these problems and to achieve the goal of

maintaining desired indoor environment quality. The structure of this controller contains two main parts: a typical conventional PID control for controlling indoor air temperature and a fuzzy logic controller to regulating the parameters for the PID controller according to the current indoor conditions. Theoretically, based on the discussion of the algorithm of the proposed controller, the indoor environmental quality can be well control since:

- PID controller is suitable for various control object including indoor climate factors control,
- fuzzy logic control for optimal PID parameters tuning to ensure adaptability to different situations,
- better PID control parameters selection can ensure the desired system output.

RBFNN-PID

The factors that affect the indoor relative humidity control can be concluded as:

- time delay,
- system response lag behind the indoor climate change,
- influence caused by temperature.

Based on this condition, a radial basis function (RBF) neural network based PID control was designed to solve these problems in order to achieve the goal of maintaining desired indoor humidity. The proposed controller has two main parts: a typical conventional PID control for controlling indoor air temperature and a radial basis function to regulating the parameters for the PID controller according to the current indoor conditions. Theoretically, based on the discussion of the algorithm of the proposed controller, the indoor humidity can be well control since:

- PID controller is suitable for various control object including indoor humidity control,
- RBF neural network has fast processing speed to ensure that best PID value can be obtained as long as there is indoor climate change, in which way the stability and adaptability of the proposed controller can be guaranteed.
- better PID control parameters selection can ensure the desired system output,

BPNN-PID

As it summarised in Chapter 2, the indoor environment control has many difficulties and the difficulties of indoor air quality control can be concluded:

- time delay,
- system response lag behind the indoor climate change,
- mismearsurement occurred.

Based on this condition, a BPNN-PID control was designed to solve these problems and to achieve the goal of maintaining good indoor air quality. The proposed BPNN-PID controller combined a typical PID controller and a neural network which the back-propagation algorithm is applied to. This design has two main parts: a typical conventional PID control for controlling indoor air quality and a back-propagation neural network to regulating the parameters for the PID controller according to the current indoor conditions. Theoretically analysis according to literatures introduced in Chapter 2 and algorithm design described in this chapter showed that the proposed BPNN-PID IAQ controller has the following potentials:

- PID controller is suitable for various control object including IAQ,
- neural networks for optimal PID parameters tuning to ensure quick recovery

from disturbances,

- back-propagation algorithm for adjustment of weights in neural network to ensure the system quickly response to indoor climate change.

Chapter 4 Simulation and Results

The detail designs of the proposed controllers were introduced in Chapters 3. In order to achieve the goal of a comfortable and healthy indoor environment quality, indoor temperature, indoor humidity and indoor air quality must be all controlled properly. Therefore, three controllers: fuzzy-PID controller, radial basis function neural network based PID controller and back propagation neural network based PID controller were proposed in Chapter 3.

In this Chapter, the performance of the proposed controllers is presented. The simulating tests of the control processes are based on the mathematical models of the indoor climate that are discussed in Chapter 3. The simulations have been taken on the platform of Matlab. The controllers' performance including over shot, response speed, adaptability, robustness and etc. are discussed. Then it analysed whether the proposed controllers are suitable for their control objects and process.

4.1 Simulation of fuzzy-PID controller

The fuzzy logic based PID controller is designed for indoor temperature, humidity and indoor air quality control in this research; and in this section, the simulation is carried out to analyse the fuzzy-PID performance for temperature control. Based on the difficulties of indoor temperature control discussed in Chapter 3, a fuzzy-PID control was designed to solve these problems and to achieve the goal of maintaining desired indoor air temperature. The structure of this design was discussed in Chapter 3 as it has two main parts: a typical conventional PID control for controlling indoor air temperature and a fuzzy logic controller to regulating the parameters for the PID controller according to the current indoor conditions. Theoretically analysis introduced in Chapter 3 showed that the proposed fuzzy-PID controller has the following potentials:

- PID controller is suitable for various control object including indoor

temperature,

- fuzzy logic control for optimal PID parameters tuning to ensure adaptability to different situations,
- better PID control parameters selection can ensure the desired system output,

In order to discuss and evaluate the proposed design, the simulating tests have been done by using the Matlab code in this section. Then the simulating results are used to indicate the controller's performance based on several indexes:

- time delay
- response speed
- time constant,,
- overshoot,
- stability,
- adaptability.

Then whether the proposed controller can achieve the targeted indoor air temperature control requirement is discussed based on the controller's performance on the listed indexes. The transfer function representing the control object expressed by equation (3-24) is used in the simulating test.

$$\frac{T_i(s)}{Q_{hl}(s)} = \frac{0.028}{506.52 \cdot s + 1} \quad (3-24)$$

4.1.1 Test using step input

In this project, the indoor temperature is controlled by the heater in air supply channel. It is related to the heater's work power and the heat loss through the wall. An intelligent PID controller based on fuzzy logical controller is proposed for the

indoor air temperature control in this project. The controller is designed based on the model of an office space as discussed in Chapter 3. During the simulating tests, the mathematical model and transfer function of the indoor temperature change as given by equation (3-24) is used to for accurately evaluating controller's performance. The simulation was carried out using the Matlab software. A screenshot while doing the simulation is presented in figure 4-1 and the code of the control program is given in Appendix A.

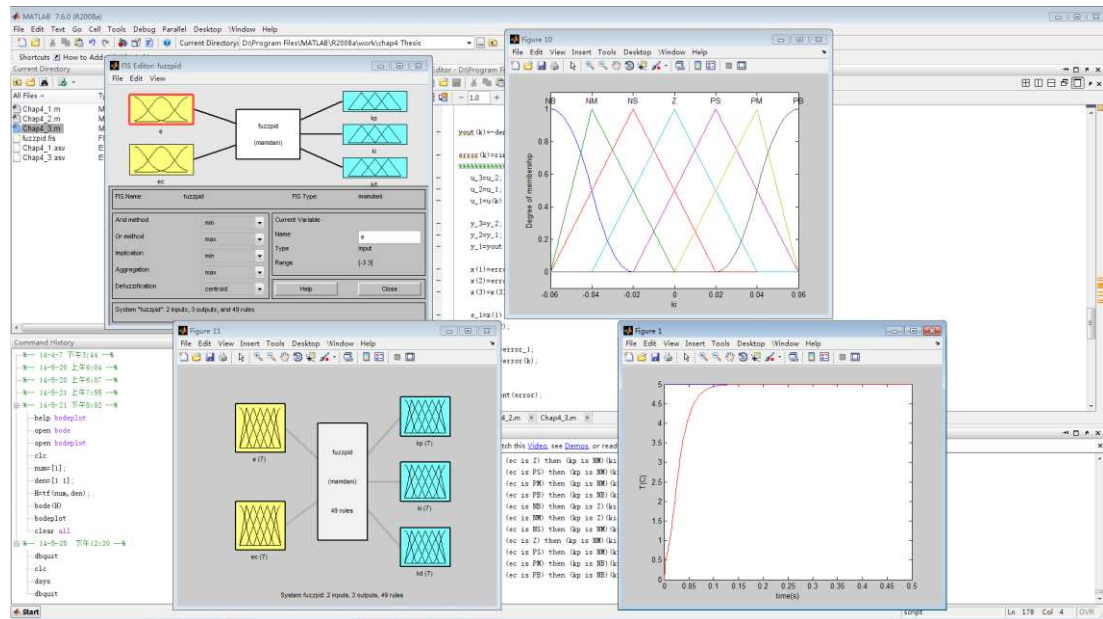

Figure 4-1 Screen shot of Matlab program

Assume the initial indoor temperature is uncomfortable and is needed to be changed. Then the desired temperature is set and the controller starts working in order to bring the indoor temperature to the wanted level. The step signal can be used to simulate this process. Hence, a step signal is used as the reference input to test the proposed controller's performance. Assume the temperature difference between the indoor and outdoor temperature is 5°C . So the step signal ($r(k)=5$) is introduced at time $t=0$ and simulation result of the proposed control system output is presented in Figure 4-2. As shown in the Figure, The time constant $\tau=0.033\text{s}$, settling time $t_s=0.092\text{s}$ and it can be seen that the control quickly response to the input signal with fast rising speed.

Besides the fast response speed, there is no overshoot in this control process. Moreover, it can be observed that when the control process settles, the steady state error is 0. This means the proposed control has excellent performance on fast response speed, avoiding overshoot, control accuracy and stability.

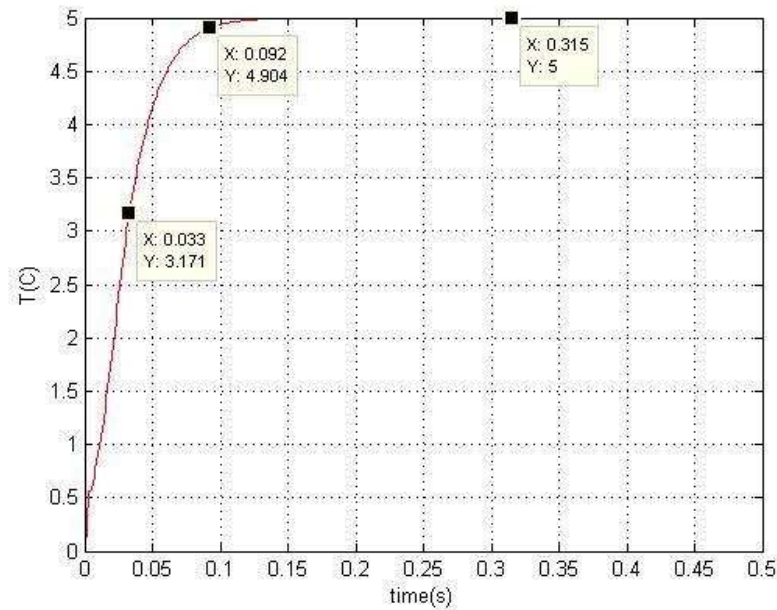

Figure 4-2 System output response to step input

In Figure 4-3, PID controller output response to the step input signal is presented. It can be seen that the controller calculated the output (control command) for the plant (command was sent to the equipment and the change the indoor temperature quality) Then the system out changes based on the controller's output and the system output can be observed in Figure 4.2. At the beginning of the control process the PID control output is used to ensure the system output moving approaching the set-point value fast and avoiding overshoot. Then the PID output settles at 0 because the system is in the steady state and the steady state error is 0.

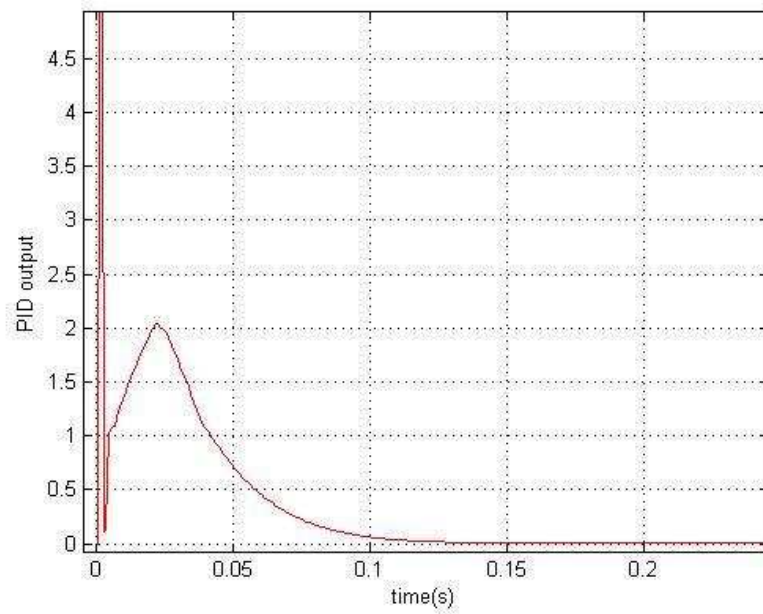

Figure 4-3 PID output response to step input

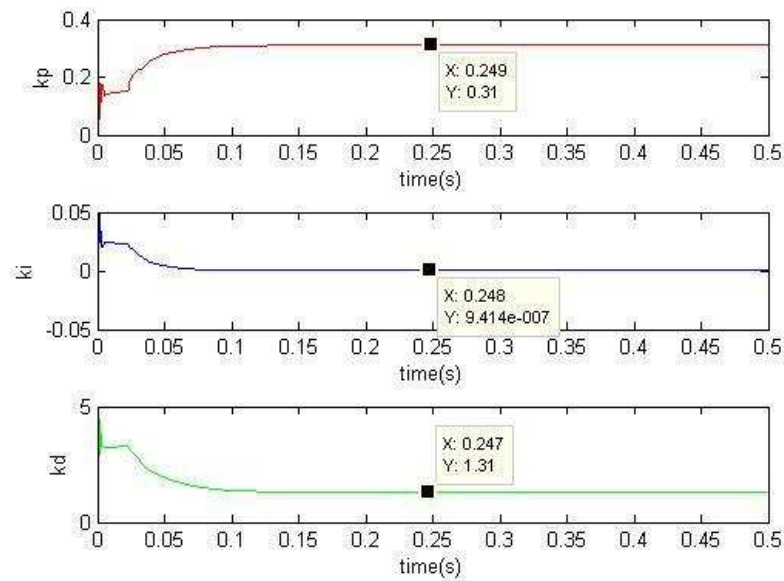

Figure 4-4 PID parameters auto tuning

The auto-regulating process of the PID parameters k_p , k_i and k_d over time can be observed in Figure 4-4. It shows at $t=0$, the $k_p=0.3$, $k_i=0$ and $k_d=2$. Then in order to ensure the system output changes fast and accurately, the PID parameters are tuned and their values are kept modifying based on the fuzzy logic control rules that is

designed in Matlab code and shown Appendix A. At last, the PID parameters' value settles at $k_p=0.31$, $k_i=0$ and $k_d=1.31$ and the system output is settled at the set-point with stable steady state shown in Figure 4-2. The result shows that different from regular PID controller, the fuzzy PID control is able to keep modifying the PID control parameters to optimize the control performance.

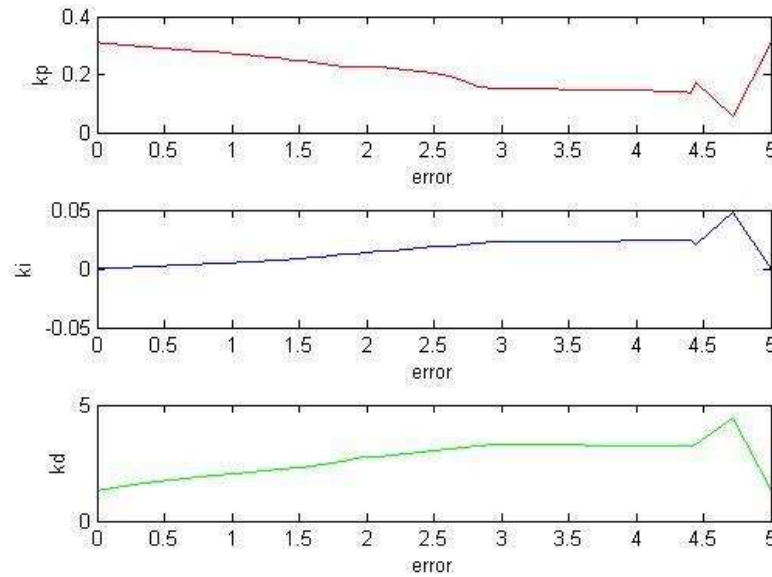

Figure 4-5 PID parameters varying based on e

Table 3-3 – Table 3-5 presented the rule base matrixes that how k_p , k_i and k_d will change (Δk_p , Δk_i and Δk_d) when e and ec varies and the membership functions of e, ec, k_p , k_i and k_d are presented in Figure 3-10 – Figure 3-14. In other words, the PID parameters are regulated based on these variables: system output error (e) and the change of system output error (ec) as presented in Figure 4-5 – Figure 4-6. It can be seen in Figure 4-6 that one ec value may represent several PID parameters sometimes. This means if only one input is applied to the fuzzy rule, the incorrect PID parameters may be produced. Therefore, with two input variables the fuzzy logic control algorithm can calculate and then provide the optimised k_p , k_i and k_d for the best control performance.

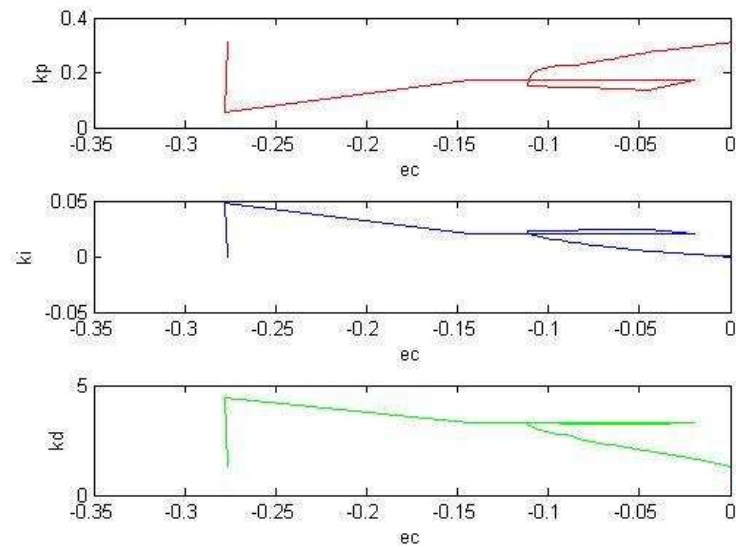

Figure 4-6 PID parameters varying based on ec

4.1.2 Fuzzy-PID control performance

The simulation works based on the mathematical model representing indoor temperature change have been carried out to indicate the fuzzy-PID control performance. The test has been done based on step input signal. As it has been shown with simulations that the fuzzy logic technique is capable of providing suitable parameters for PID controller and the targeted system output can be achieved. In detail, the proposed controller has excellent performance on:

- efficient auto tuning of the PID parameters only when needed,
- fast response speed,
- no overshoot,
- no steady error,
- stability.

The advantages make the proposed controller suitable for controlling indoor air

temperature and capable to solve the difficulties of indoor temperature control. Hence, the proposed fuzzy-PID control strategy has guaranteed the desired control performance on indoor air temperature management.

4.2 Simulating tests of RBFNN-PID control

Based the difficulties of humidity control discussed in Chapter 3, a radial basis function (RBF) neural network based PID control was designed to solve these problems in order to achieve the goal of maintaining desired indoor humidity. The structure of this design was discussed in Chapter 3 as it has two main parts: a typical conventional PID control for controlling indoor air temperature and a radial basis function to regulating the parameters for the PID controller according to the current indoor conditions. Theoretically analysis introduced in Chapter 3 showed that the proposed radial basis function neural network based PID indoor humidity controller has the following potentials:

- PID controller is suitable for various control object including indoor humidity control,
- RBF neural network has fast processing speed to ensure that best PID value can be obtained as long as there is indoor climate change, in which way the stability and adaptability of the proposed controller can be guaranteed.
- better PID control parameters selection can ensure the desired system output,
- robustness to ensure stability.

In order to discussed and evaluate the proposed design, the simulating tests have been done by using the Matlab code shown in Apendix B in this section. Then the simulating results are used to indicate the controller's performance based on several indexes:

- response speed,

- overshoot,
- time constant,
- steady state error,
- stability,
- adaptability.

Then whether the proposed controller can achieve the targeted indoor air humidity control requirement is discussed based on the controller's performance on the listed indexes. The transfer function representing the control object expressed by equation (3-25) is used in the simulating test. $H_i(s)$ in equation (3-25) is the indoor humidity which is the system output in this simulation and use y to represent it. Q_{h2} is the work power of the humidifier and is the PID output in the simulation that is represent by u . Convert continuous-time function (3-25) to discrete-time model and get $y(k)=y(k-1)+0.11u(k)+0.11u(k-1)$. This is a linear model calculate based on the ideal mathematical model. But in real control the humidity is a nonlinear system and in this simulation the following equation $y(k)=[y(k-1)+ 0.11u(k-1)]/[1+y^2(k-1)]$ is used [308].

4.2.1 Response to step input

Assume the initial indoor humidity is uncomfortable and is needed to be changed. Then the desired humidity is set and the controller starts working in order to bring the indoor humidity to the wanted level. The step signal can be used to simulate this process. Hence, a step signal is used as the reference input to test the proposed controller's performance. After several tests, set the best initial learning rate $\eta=0.25$ and momentum factor $\alpha=0.05$. With these preset values the best control performance is obtained.

Assume the humidity difference between the indoor and outdoor temperature is 50%.

So the step signal ($r(k)=0.5$) is introduced at time $t=0$ and simulation result of the proposed control system output is presented in Figure 4-7. As shown in the Figure, time constant $\tau=0.022s$, settling time $t_s=0.335s$ and it can be seen that the control quickly response to the input signal with fast rising speed. Besides the fast response speed, there is no overshoot in this control process. Moreover, it can be observed that when the control process settles, the steady state error is 0. This means the proposed control has excellent performance on fast response speed, avoiding overshoot, control accuracy and stability.

The Jacobian matrix has to be produced at the beginning of the simulating tests and then keeps been modified over time based on three input variables: PID output u , system output y and the system output at previous sampling step $y(k-1)$. The good system output results including fast response speed and no overshoot prove that the processing speed of the calculating the Jacobian information is fast for getting the targeted system output in time. Then the system output curve enters the steady state and the steady error is zero. It has to be clear that the steady error is zero in the simulation work but the system error generally exists in real control.

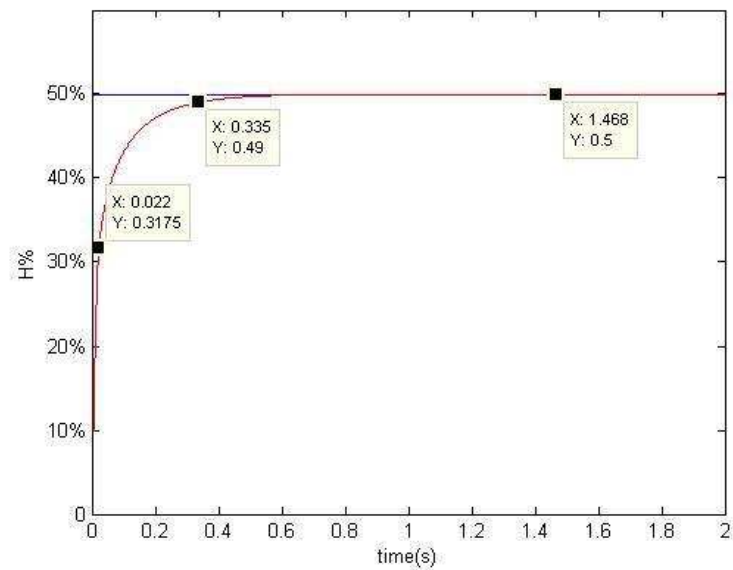

Figure 4-7 System output response to step input

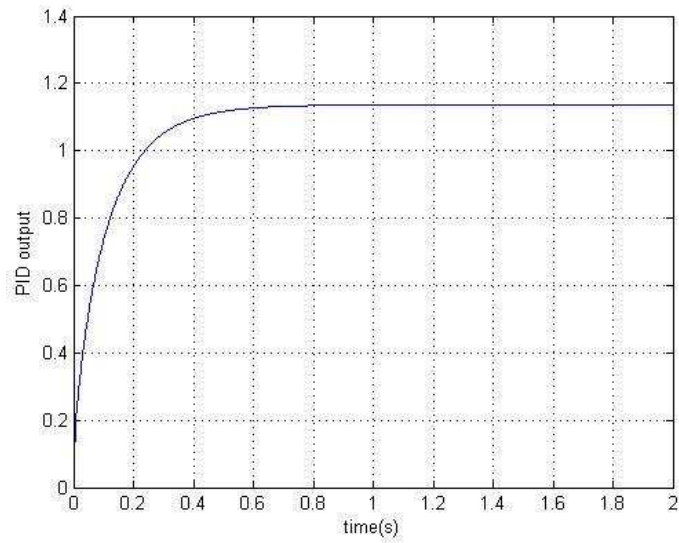

Figure 4-8 PID output response to step input

In Figure 4-8, output of PID controller response to the step input signal is presented. It can be seen that the controller calculated the output (control command) for the plant (command was sent to the equipment and the change the indoor humidity). With controller output the good result of system output can be ensured.

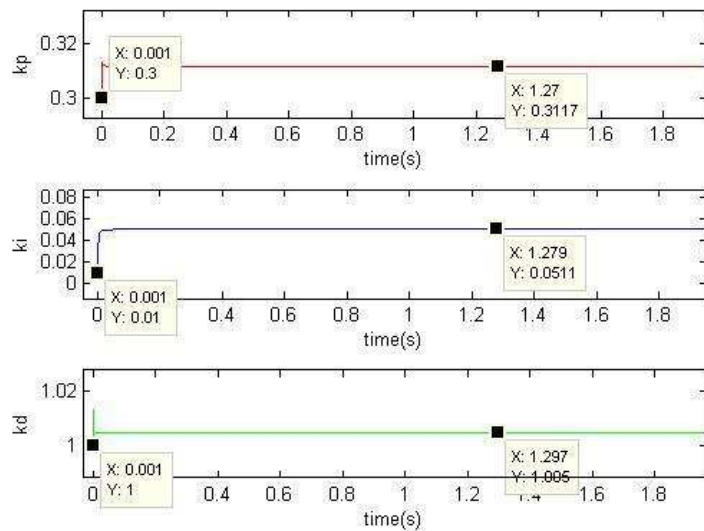

Figure 4-9 PID parameters regulating process

The auto-tuning process of the PID parameters k_p , k_i and k_d can be observed in Figure 4-9. It shows that at the beginning of the control process $k_p=0.03$, $k_i=0.01$ and $k_d=1$. Then the value of the PID control parameters keeps being modifying based on the control of the RBF neural network. Since the system output in Figure 4-7 shows good results it proves that the neural network is able to automatically tune the k_p , k_i and k_d parameters to optimize the control performance until the system enters the steady state. Then when the system enters the steady state, the PID parameters settle at $k_p=0.03$, $k_i=0.05$ and $k_d=1.01$.

In the RBF neural network, the PID output u , system output y and the system output at previous sampling step $y(k-1)$ are used to calculate the Jacobian value. The Jacobian value starts being calculated at the beginning of the simulating tests and then keeps been modified over time as shown in Figure 4-10. Then the PID parameters are obtained based on the Jacobian as shown in Figure 4-11.

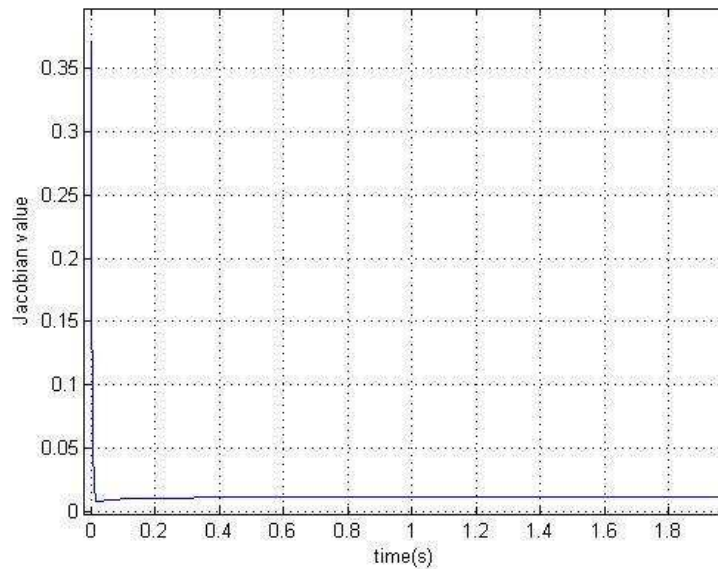

Figure 4-10 Jacobian value

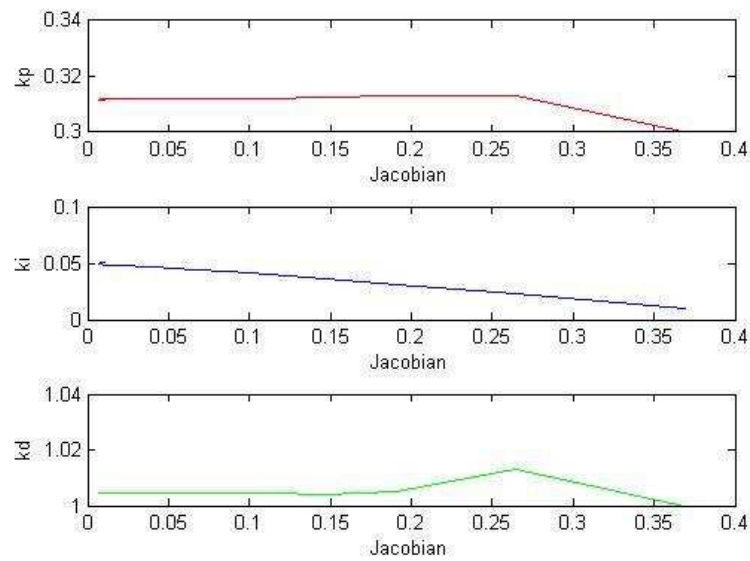

Figure 4-11 PID parameters tuning related to Jacobian value

Equation (3-43) – Equation (3-45) have expressed how the neural network regulates the PID parameters in the proposed control strategy. These equations also presents that the values of PID terms are updated based on the system error, the change of system error and the second differential of the system output. The Jacobian matrix is calculated based on the PID output u , system output y and the system output at previous sampling step $y(k-1)$. In other words, the regulation of the PID parameters using RBF neural network is a complex mission and the tuning process based on Jacobian information is shown in Figure 4-11. It presents that the k_p , k_i and k_d are kept modifying for the optimised values along with change of Jacobian values.

4.2.2 Response to square input

The Figure 4-19 presents the PID parameters regulation during the control process. The PID parameters value only changes at beginning of the control process. After the system enters the steady state the PID parameters settle unchanged. Hence, another input signal is applied to further investigate the PID parameters tuning function of the RBF neural network. Based on the equation (3-35) and (3-43)-(3-45), when the output value y is suddenly changed, the PID parameters will be changed. Moreover,

as shown in Figure 4-7, the system output can be changed rapidly response to the input change. Hence the value of input signal needs to be able to suddenly changed regularly. Among all of such signals, the square signal is commonly used and will be applied in this simulation work to test the PID parameters regulation during the control process.

A square input ($\text{sign}(\sin(2\pi t))$) is introduced to at time $t=0$ to verify the performance of the RBF neural network based PID controller. In Figure 4-25, system output response to the square input is presented. Between time $t=0$ and $t=0.5\text{s}$, the input can be equivalent to a step signal $r=1$ and the time constant $\tau=0.029\text{s}$, settling time $t_s=0.375\text{s}$. This results is similar as that is presented in Figure 4-7.

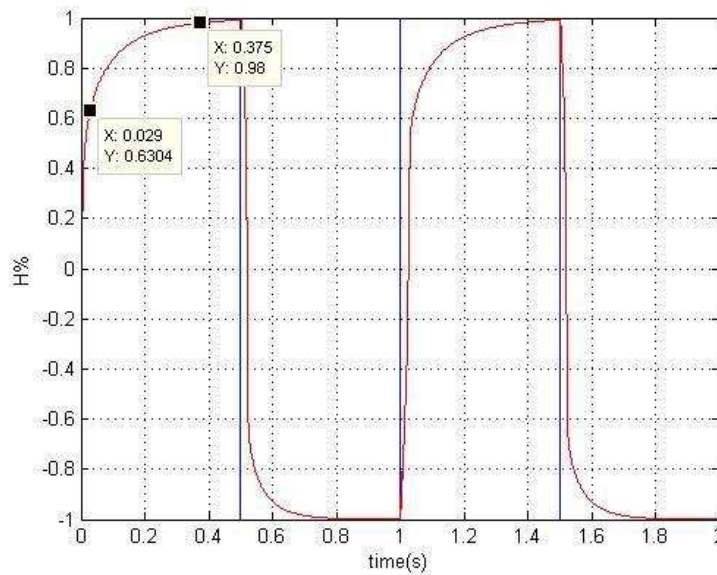

Figure 4-12 System output response to square input

The curves of system output y and network output y_m are presented in Figure 4-13, it can be seen that between time $t=0.4$ and $t=0.5$ the values of y and y_m are the same which means the error between them is a constant value zero. Then based on Equation (3-35) the performance index is a constant value zero and the Jacobian value remains unchanged in the period as shown in Figure 4-14. Hence, the PID parameters are unchanged during this period based on Equation (3-43) – Equation

(3-45) and the theoretical analysis is proved by the profile shown in Figure 4-15. This also explains other periods when the PID terms values are not changed.

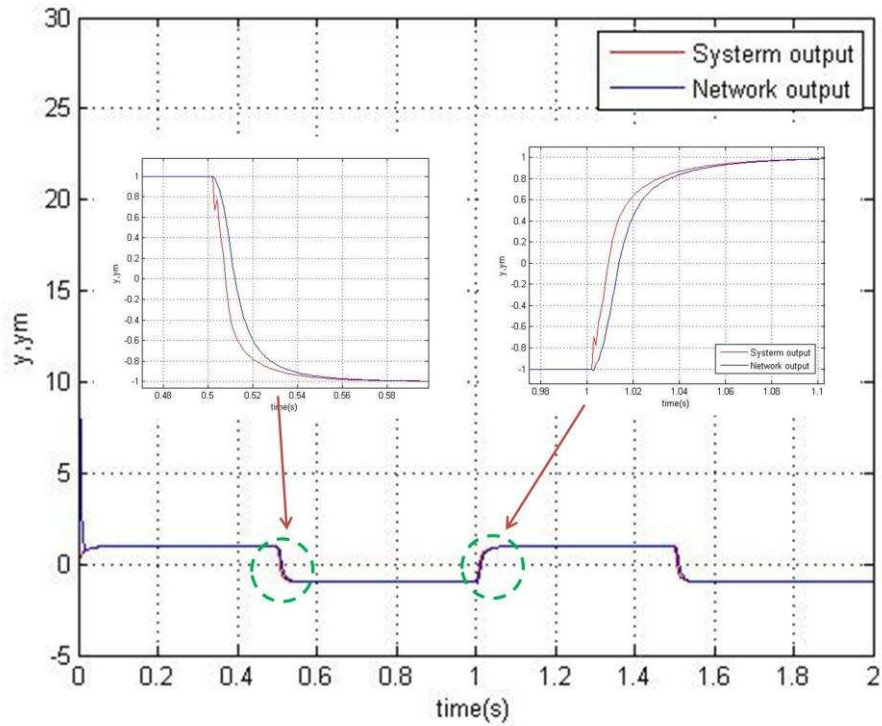

Figure 4-13 network output response to square input

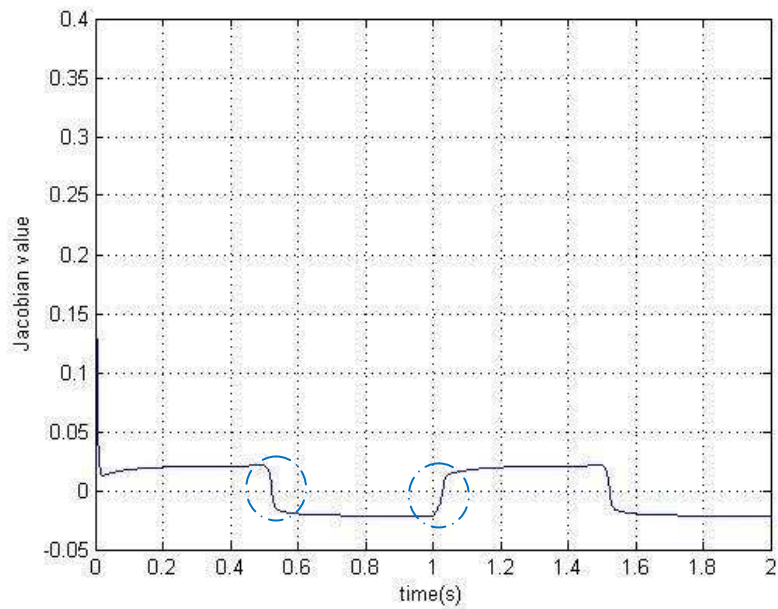

Figure 4-14 Jacobian value

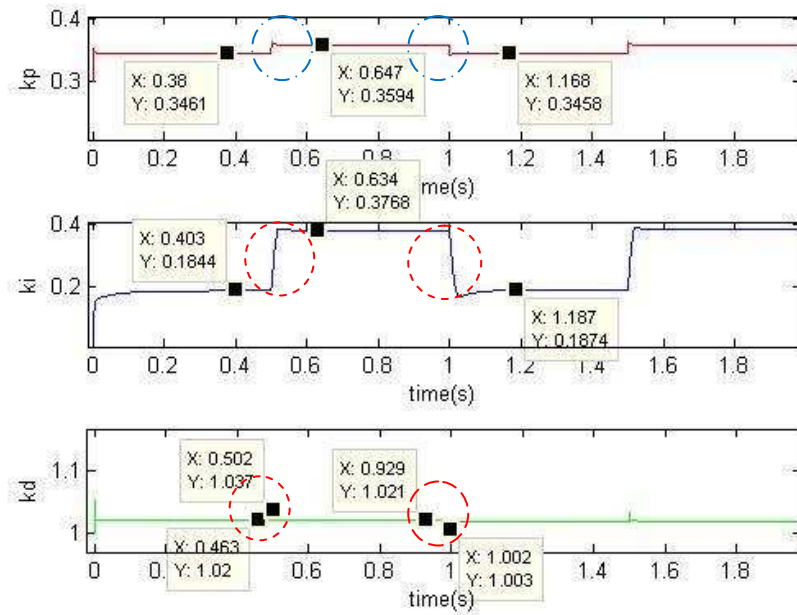

Figure 4-15 PID parameters regulating process

At time $t=0.5$ and $t=1.0$ when the value of the square curve changes, the system output y is changing associate with the square signal in order to tracking the reference input. As a result, the value of the network output y_m changes as well since y is one of the network inputs as shown in Figure 4-13. Then the value of the performance index keeps changing based on Equation (3-35) during this square value changing period. This leads to the fact that Jacobian value changes during the period and the simulating result can be observed in Figure 4-14. Finally the PID parameters are modified as demand based on Equation (3-43) – Equation (3-45) as presented in Figure 4-15. This regulation process is occurred every time when the value of the square signal change in this control process as shown in Figure 4-15. Hence, different from the traditional PID controller, the RBFNN PID controller is able to automatically tune the PID parameters to meet the control requirement.

Equation (3-43) – Equation (3-45) have expressed how the neural network regulates the PID parameters in the proposed control strategy. They have showed that the regulation of the PID parameters using RBF neural network is a complex mission

and the tuning process based on Jacobian information is shown in Figure 4-16. It presents that the k_p , k_i and k_d are kept modifying for the optimised values along with change of Jacobian values. It can be also that seen in these figures that one variable Jacobian value may represent several values of PID terms sometimes. This means that if only one input is applied to the neural network, the incorrect PID parameters may be produced. Hence, beside Jacobian value the PID parameters are also regulated based on the system error, the change of system error and the second differential of the system output to ensure the best values.

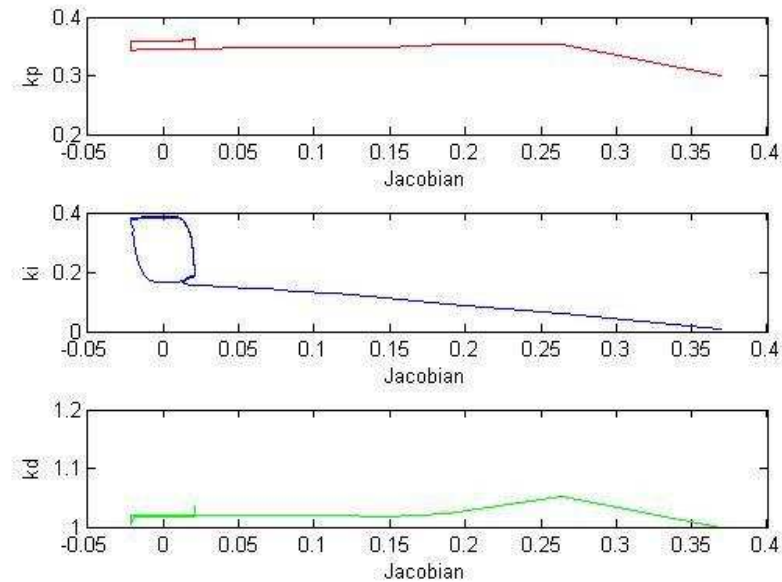

Figure 4-16 PID parameters tuning related to Jacobian value

4.2.3 RBFNN-PID control performance

The simulating tests based on the indoor humidity varying model have been conducted in order to evaluate the performance of the proposed RBF neural network based PID controller. Two reference inputs have been applied to the control process: step signal and square signal. The step input is used to simulate indoor humidity change and to test the controller's performance. The square input is used to investigate the PID parameters regulation function of the RBF neural network. As it

has been shown with simulations, the RBF neural network technique is capable of providing suitable parameters for PID controller and the targeted system output can be achieved. In detail, the proposed controller has excellent performance on: online training for the PID parameters, fast response speed, high control accuracy, coping with the time varying parameter, stability and adaptability. The advantages make the proposed controller suitable for controlling indoor humidity and capable to solve the difficulties of indoor humidity control as discussed in Chapter 3. Hence, the proposed RBFNN-PID control strategy has guaranteed the desired control performance on indoor humidity management.

4.3 Simulating tests of BPNN-PID control

A BPNN-PID control was designed to solve the difficulties of indoor air quality control and to achieve the goal of maintaining good indoor air quality. The proposed BPNN-PID controller combined a typical PID controller and a neural network which the back-propagation algorithm is applied to. The structure of this design was discussed in Chapter 3 as it has two main parts: a typical conventional PID control for controlling indoor air quality and a back-propagation neural network to regulating the parameters for the PID controller according to the current indoor conditions. Theoretically analysis according to Chapter 3 showed that the proposed BPNN-PID IAQ controller has the following potentials:

- PID controller is suitable for various control object including IAQ,
- neural networks for optimal PID parameters tuning to ensure stability,
- back-propagation algorithm for adjustment of weights in neural network to ensure the system quickly response to indoor climate change.

In order to discussed and evaluate the proposed design, the simulating tests have been done by using the Matlab code shown in Appendix C in this section. Then the

simulating results are used to indicate the controller's performance based on several indexes:

- response speed,
- overshoot,
- time constant,
- stability,
- adaptability.

Then whether the proposed controller can achieve the targeted indoor air quality control requirement is discussed based on the controller's performance of the listed indexes. Thus simulations are used to conduct and results are analysed to discuss the performance including of the proposed control strategy in IAQ control. During the simulating tests, the accurate mathematical model of the real control objects that in this case is the CO₂ concentration in a monitored indoor environment. Thus, the mathematical model and transfer function for the IAQ control in this project was introduced in Chapter 3. Slightly change has been made to the theoretical transfer function to make it more accurate to the real environment and it is given as:

$$y(k) = \frac{a(k) \cdot y(k-1)}{1 + y^2(k-1)} + u(k-1) + 0.2u(k-2) \quad (4-1)$$

where $a(k)$ is a parameter varying over time and it is given as $a(k) = 1.4(1 - 0.9e^{-0.3k})$.

The biggest change is to add a time varying parameter represented to the indoor CO₂ concentration change to the uncertain and unpredictable parameters. For example, doors opening while people entry or leave the room may cause disturbance to the system. Hence, function (4-1) is used to assess the effectiveness of the proposed neural PID control with on-line learning approach. As the process parameter

becomes time variant, it causes difficulties to the system reference tracking control.

4.3.1 Response to step input

As usual, the step signal is used to for simulation test. After several tests, set the best initial learning rate $\eta=0.28$ and momentum factor $\alpha=0.04$.The weights in the neural network are initialized in the range $[-0.5, 0.5]$ randomly. The randomly preset weights may cause a little unstable to the control process but the back-propagation algorithm is able to quickly response to any uncertain parameters and the weights of neural network are updated in relative short time to ensure the targeted output.

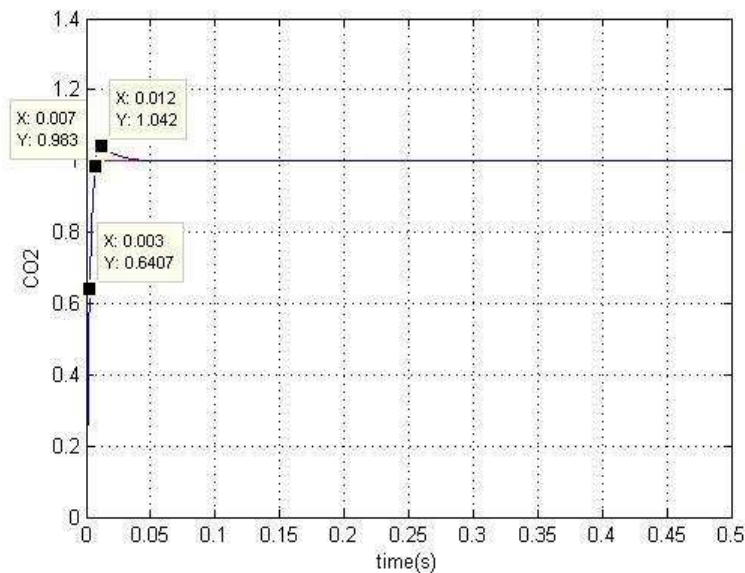

Figure 4-17 System output response to step input

The step signal ($r(k)=1$) is introduced at time $t=0$. The simulation result of the proposed control system output is presented in Figure 4-17. As shown in the Figure, the system has very fast rising speed as well as very small overshoot. The time constant $\tau=0.003s$, settling time $t_s=0.007s$ and the maximum percent overshoot $\sigma = 4\%$. The uncertainty might be caused by randomly preset weight values of neural network have not significant disturbed control process at the beginning of response as the curve rising fast. Then it is brought back to the set-point before the

overshoot is still very small, 4% in this simulation work and the control process is brought to the steady state, the steady error of which is zero as shown in profile. It has to be clear that the steady error is zero because the control object function is calculated based on an ideal model of the indoor climate and the system error generally exists in real control process.

In Figure 4-18, PID controller output response to the step input signal is presented. It can be seen that the controller calculated the output (control command) for the plant (command was sent to the equipment and the change the indoor air quality). The system output results in Figure 4-17 prove that the controller is able to obtain required output to ensure good performance on fast and accurate control.

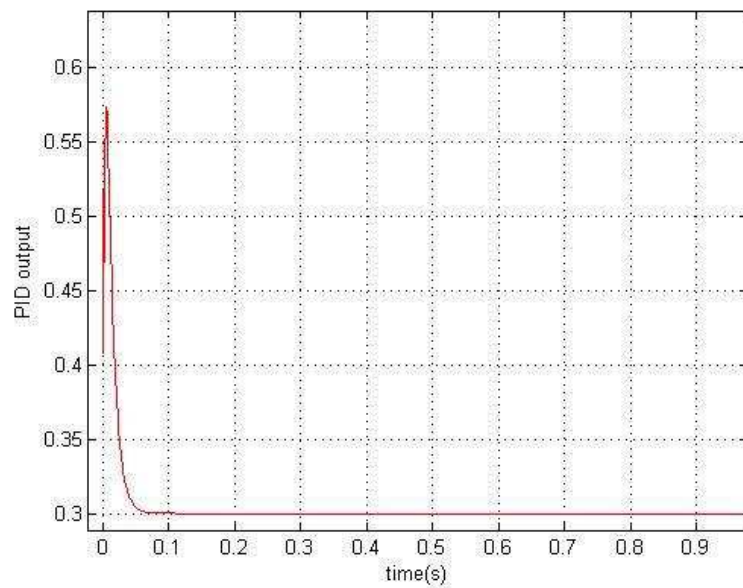

Figure 4-18 PID output response to step input

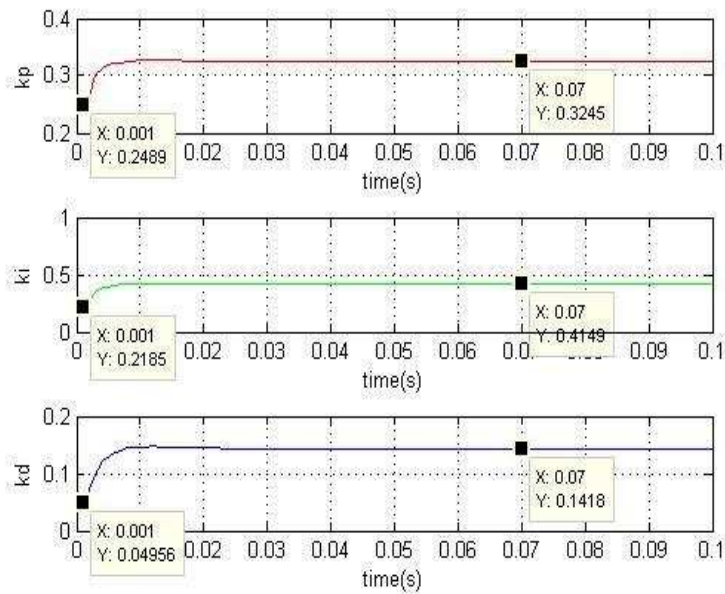

Figure 4-19 PID parameters auto regulating

The auto-tuning process of the PID parameters k_p , k_i and k_d can be observed in Figure 4-19. It shows that $k_p= 0.25$, $k_i=0.23$ and $k_d=0.05$ at the beginning of the control process and the PID parameters are tuned by the neural network during the control process. The system output results in Figure 4-17 shows good control performance. This means that the proper PID parameters can be obtained using the online training algorithm based neural network control scheme. The value of the PID control parameters are kept modifying to optimize the control performance until the system enters the steady state. Then after the system enters the steady state the PID parameters are settled at $k_p= 0.33$, $k_i=0.042$ and $k_d=0.14$ and kept stable.

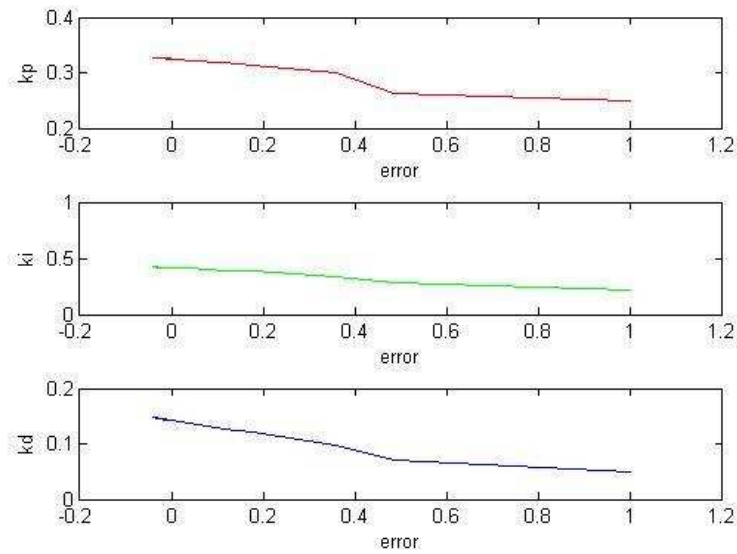

Figure 4-20 Relation between PID parameters and system error

Equation (3-53) presented the input of the neural network in the proposed control strategy. In other words, the PID parameters are regulated based on these variables: system output error (e), change of system output error (ec), PID controller output error (u) and system output (u) as presented in Figure 4-36 – Figure 4-39. It can be seen in Figure 4-37 and Figure 4-38 that one ec value or u value may represent several PID parameters sometimes. This means if only one input is applied to the neural network, the incorrect PID parameters may be produced. Therefore, with four input variables the design BPNN algorithm can calculate and then provide the optimised k_p , k_i and k_d for the best control performance.

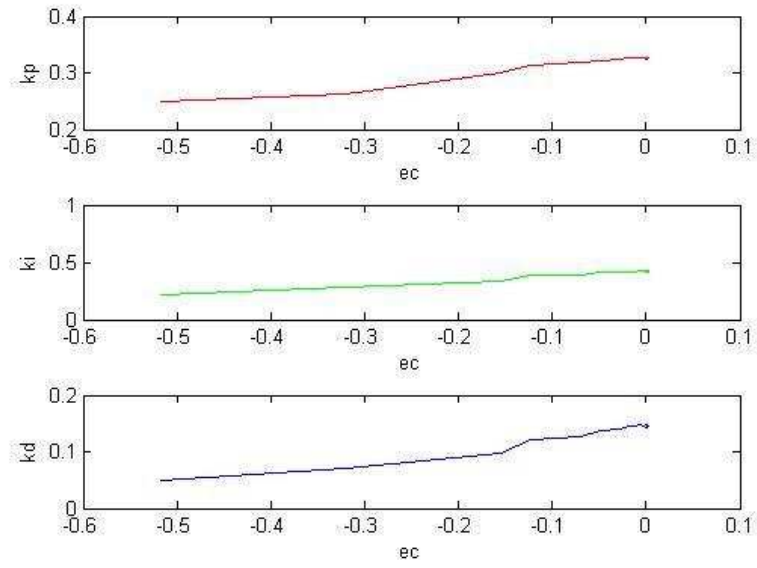

Figure 4-21 PID parameters response to ec

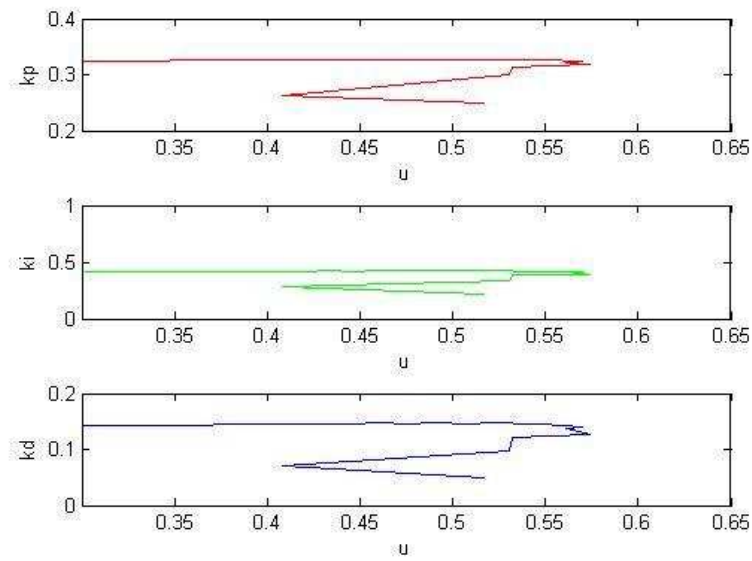

Figure 4-22 PID parameters response to PID output

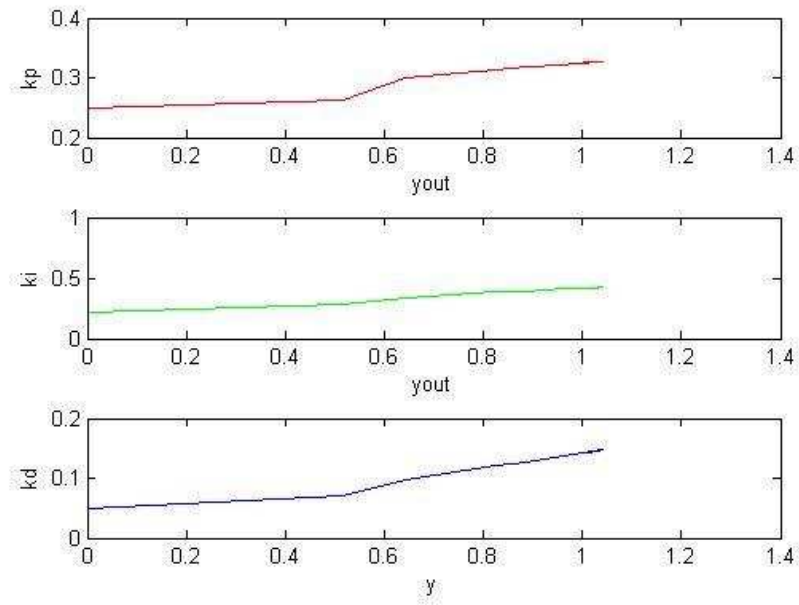

Figure 4-23 PID parameters response to system output

4.3.2 BPNN-PID control performance

In order to evaluate the BPNN-PID control performance, the simulating tests based on the indoor CO₂ concentration varying model have been carried out. Two reference inputs have been applied to the control process: step signal and sine signal. As it has been shown with simulations that the back-propagation neural network technique is capable of providing suitable parameters for PID controller and the targeted system output can be achieved. In detail, the proposed controller has excellent performance on:

- tuning PID parameters as demand,
- fast rising speed and settling speed,
- small overshoot,
- small steady error,

- coping with the time varying parameter,
- stability and adaptability.

The advantages make the proposed controller suitable for controlling indoor air quality and capable to solve the major problems of indoor CO₂ control including time delay, existence of mismeasurement and disturbances like more people suddenly enters the indoor space since CO₂ is very sensitive to occupancy level. Hence, the proposed BPNN-PID control strategy has guaranteed the desired control performance on indoor air quality management.

4.4 Summary

In this Chapter, simulating tests were carried out to evaluate the proposed controllers: fuzzy-PID controller for indoor temperature, radial basis function neural network based PID controller for indoor humidity control and back propagation neural network based PID controller for indoor air quality control. The simulating results were discussed to analyse the controllers' performances on the indexes including response speed, stability, overshoot and time constant. At last the potential of the designed controllers for indoor environment quality control is discussed based on the simulating results.

Fuzzy-PID control

Simulation was carried out for indicating the proposed fuzzy-PID controller. The step and input signal is used as the control reference. The results have proved the proposed controller has excellent performance on efficient auto tuning of the PID parameters only when needed; fast response speed; small overshoot; small steady error; and stability and adaptability response to uncertain factors. In other words the proposed intelligent temperature controller may have excellent performance on indoor temperature control as:

- indoor temperature can be well controlled by PID controller,
- PID parameters auto tuning can ensure better PID control performance,
- PID parameters regulation based on fuzzy logic rule to ensure adaptability to different situations in temperature control process,
- robustness to ensure stability.

These advantages make the proposed controller suitable for solving the major difficulties in indoor temperature control including time delay, influence caused by humidity and etc.

RBFNN-PID control

The newly radial basis function neural network based PID controller is evaluated by simulating tests based on the indoor humidity model. Two reference inputs have been applied to the control process: step signal and square signal. As it has been shown in simulation results the proposed controller has excellent control performances on: online training for the neural network; auto tuning of the PID parameters; high control accuracy; coping with the time varying parameter; stability and adaptability. These may ensure good indoor humidity control performance since the proposed RBFNN-PID controller is able to:

- obtain the best PID values as long as there is indoor climate change since the RBF neural network has fast processing speed;
- guaranteed adaptability because of fast response speed;
- ensure stability and quick recovery from disturbances;

These advantages make the proposed controller suitable for solving the major difficulties in indoor humidity control including time delay, influence caused by temperature and etc.

BPNN-PID control

The simulating tests based on the indoor CO₂ concentration varying model have been carried out to indicate the BPNN-PID control performance. As it has been shown with simulations that the back-propagation neural network technique is capable of providing suitable parameters for PID controller and the targeted system output can be achieved. In detail, the proposed controller has good control performance as follows: online training of the controller as demand; fast rising speed and settling speed; small overshoot; small steady error; coping with the time varying parameter; stability and adaptability.

These make the proposed controller suitable for controlling indoor air quality and capable to solve the major problems of indoor CO₂ as discussed in Chapter 3 since discussion of the performance indexes has proved that:

- PID controller is suitable for various control object including IAQ,
- neural networks for optimal PID parameters tuning to ensure controller's stability,
- back-propagation algorithm for adjustment of weights in neural network to ensure the system quickly response to indoor climate change.

Chapter 5 Experimental investigation

The experimental investigation of the novel designed fuzzy-PID controller for indoor environment quality improvement including temperature, humidity and CO₂ concentration control is introduced in the chapter. Experiments for investigating the performance of the RBFNN-PID controller and BPNN-PID controller are introduced in Section 6.3: Future work. Firstly, the experimental setup and the control process of the experiments are introduced in detail. Then, the data collected from the experiments are shown in curves or processed with signal processing methods. At last, the controllers are evaluated based on the experimental investigation.

5.1 Experimental setup

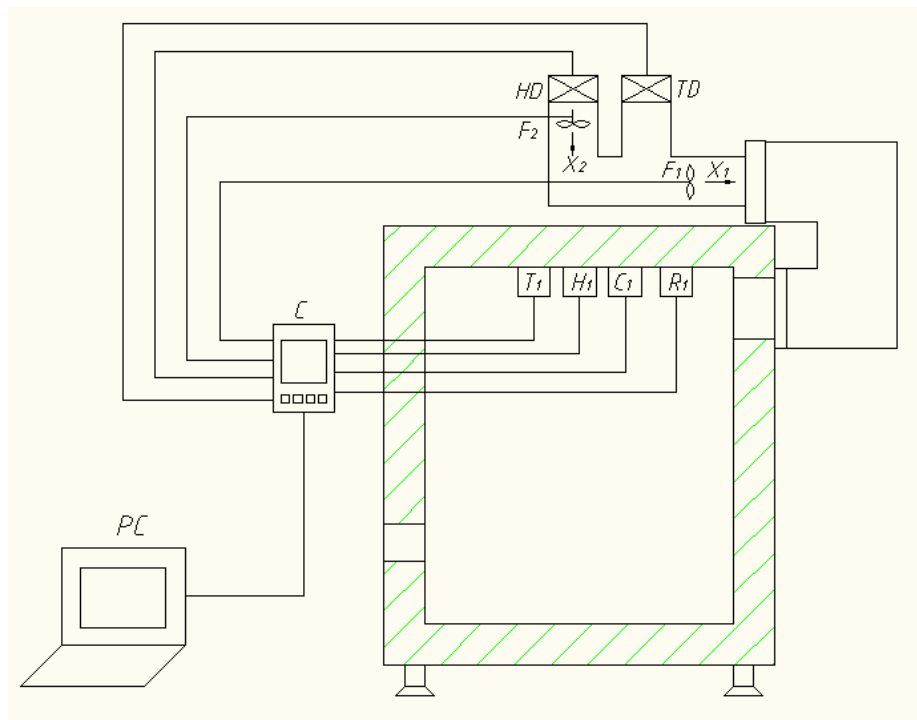

Figure 5-1 System schematic graph

In this section, the design of test rig on which the experiments are carried out is introduced. As it discusses in previous chapters, the control parameters of this project are the temperature, relative humidity and carbon dioxide concentration in a medium office. The test was carried out in the rig as shown in Figures 5-1 and 5-2.

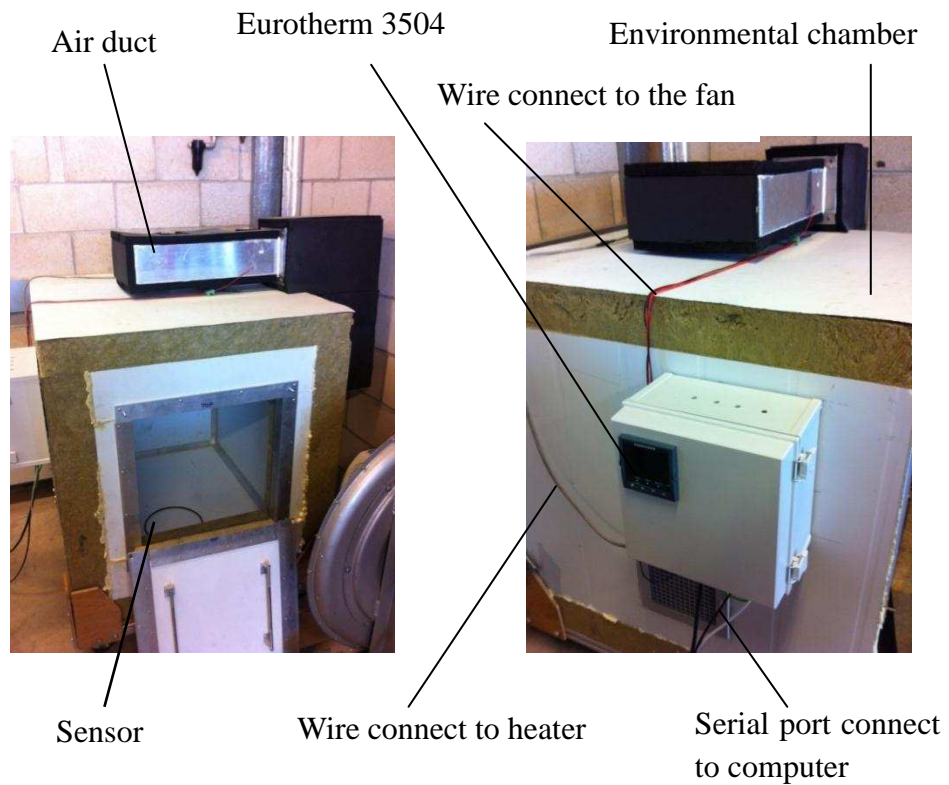

Figure 5-2 Photos of test rig

It can be seen in this figure that the test rig contains the following parts:

The environmental chamber: used to represent the controlled indoor space as shown in Figure 5-1 – Figure 5-3.

Air duct: used to supply the air-conditioned air with certain temperature and humidity and its design is shown in Figure 5-3.

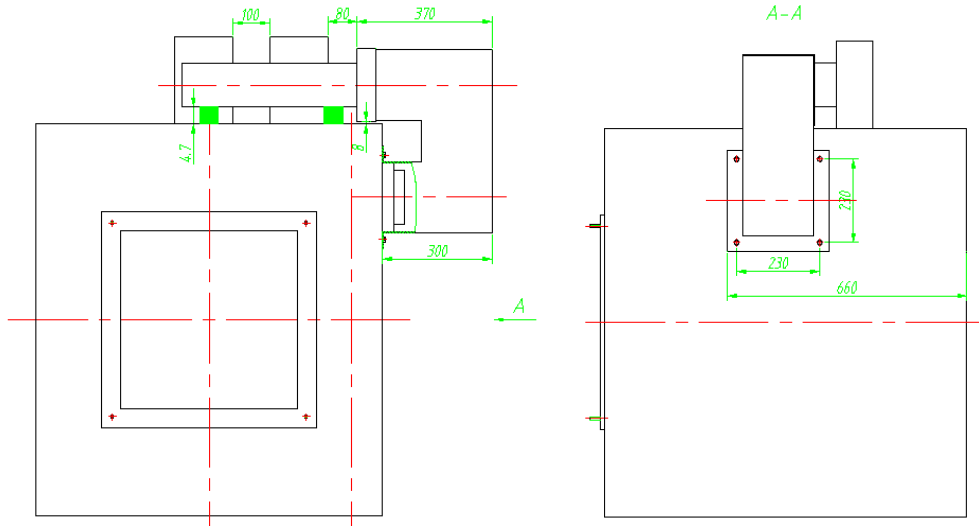

Figure 5-3 Schematic diagram of environmental chamber and air duct

Thermal couple: used to measure the indoor temperature as shown in Figure 5-4.

Humidity sensor: used to measure the indoor relative humidity as shown in Figure 1-8 and its specifications are also listed in Table 5-1.



Thermocouple type	K
Max temperature sensed	250°C
Min temperature sensed	-50°C

Figure 5-4 Photo of thermocouple



Figure 5-5 Photo of humidity sensor

Table 5-1 Specification of humidity sensor

Humidity sensor type	HIH-4000 Series
Operating temperature	-40°C – 85°C
Operating humidity	0 – 100 (%RH)
Supply voltage	4 – 5.8 (Vdc)
Current supply	500 (μ A)
Voltage output	$V_o = V_s(0.0062 \cdot RH_s + 0.16)$
Accuracy	3.5%

CO₂ sensor: used to measure the indoor CO₂ level as shown in Figure 5-6 and Table 5-2 where its important specifications are also listed.

Table 5-2 Specification of CO₂ sensor

Model No.	CDM4161
Operating temperature	-10°C – 40°C
Operating humidity	5 – 70 (%RH)
Supply voltage	5.0 \pm 0.2 (Vdc)
Warm up time	2 hours
CO ₂ concentration signal	0~4V DC = 0~4,000ppm
Accuracy	\pm 20%



Figure 5-6 Photo of CO₂ sensor

Eurotherm 3504 Controller [309] shown in Figure 5-7 and table 5-3: used as signal input/output device and to send control command to equipments. Since the software LabVIEW can be used to program the Eurotherm 3504 controller and is a very convenience and powerful software for controller design and implement, it is utilized in this research. The program used operate the controller is introduced in Section 5.2

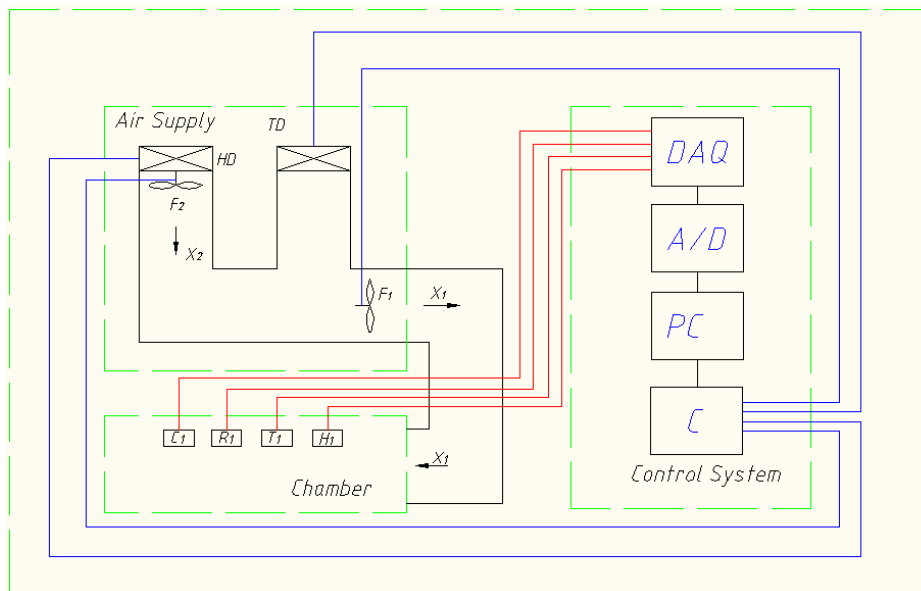

Figure 5-7 Photo of the controller [309]

Table 5-3 I/O module of controller

I/O module	Connected device
Input	
Built in module	Thermal couple
Analog module	Humidity sensor
	CO ₂ sensor
Output	
Relay module	Heater
Logic module	Humidifier
DC module	Fan

Heater, humidifier and fans: used to change the indoor climate inside the chamber based on the control command.



T1 – Thermocouple; H1 – Humidity sensor; C1 – CO₂ sensor; HD – Humidifier; TD – Heater; F1 – Fan; F2 – Fan; x1 – Air supply; x2 – Air supply; DAQ – Data acquisition system; A/D – Analog to digital converter; PC – Computer program; C – Controller.

Figure 5-8 Structure of control system

The structure of the control system and as shown in Figure 5-8 and the control process can be concluded as:

- Firstly, the sensors are used to collect the physical quantities: thermal couple to measure temperature, humidity sensor to measure relative humidity, CO₂ sensor

to measure CO₂ concentration. The actual physical quantity that humidity sensor and CO₂ sensor collected is voltage. Voltage is known as an analog signal that cannot be processed by computational application and programs directly.

- Hence, secondly, the analog signals are transferred into digital signals. Then they can be analysed and processed by designed control algorithm.
- Then, since the current control signals are collected and transmitted into digital signals, which and other relevant parameters will be processed by the control algorithm.
- At last, the controller output equaled to the command will be sent to the air-conditioning equipments which in this project are heater, humidifier and fan. Based on the controller's command, the indoor environment of the controlled space is modified to meet desired requirement.

The experiments are carried out in October, November, December, January, February and March. During this period of time, the indoor condition needs to be heated and humidified since it is colder and drier than the targeted indoor climate, so the heater and humidifier are utilized in the experiments. The CO₂ is needed to be controlled at the acceptable level as long as the air-conditioned is occupied. In the following sections, the experiment results of indoor temperature, humidity and CO₂ concentration are presented.

5.2 Program of controller

The experiments were carried out on the test rig shown in Figure 5-1 and Figure 5-2. All the important components are introduced in Section 5.1. The PID control program of the Eurotherm 3504 is used for the experiments. Since the software LabVIEW can be used to program the Eurotherm 3504 controller and is a very convenience and powerful software for controller design and implement, it is utilized

in this research. The LabVIEW driver and program for operating the Eurotherm 3504 PID controller can be downloaded from internet [310]. My work includes the design of the fuzzy logic control program using LabVIEW and then combining the fuzzy controller with the PID control program. In this way the fuzzy logic controller is applied to and combined with the PID controller. Hence, in this section, the program work of the fuzzy logic controller and how it connects to the PID control program is introduced in detail.

The users interface is shown in Figure 5-9 and its program diagram is presented in Appendix D. On this interface panel, set-point of the control signal can be set and the measured values can be observed in the chart and the measured value box.

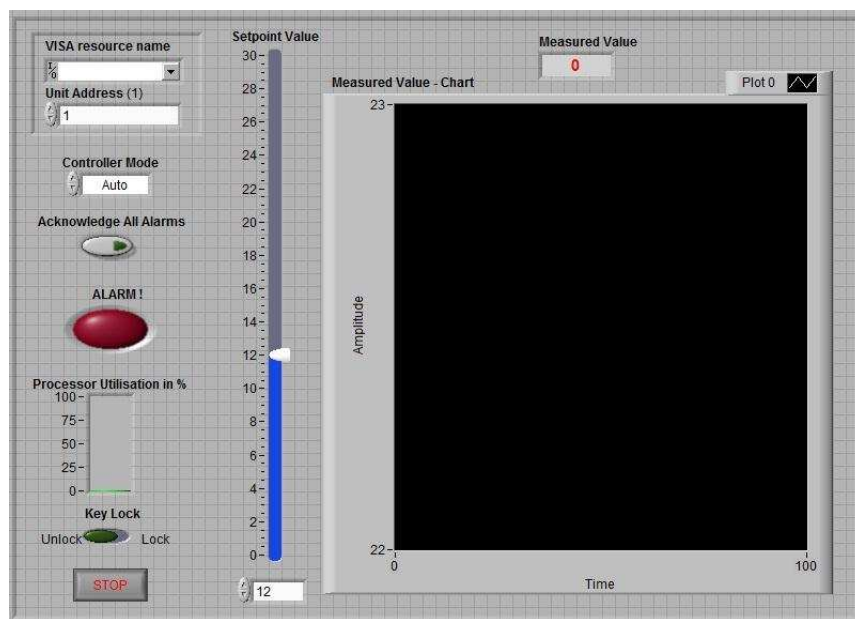

Figure 5-9 User interface of the controller

In the following part of this section, my work of fuzzy logic control program development and its connection to the PID controller are introduced in detail. Firstly, the membership functions of the input and output variables of the fuzzy logic controller are designed using the fuzzy system designer as shown in Figure 5-10 – Figure 5-12. The inputs of the fuzzy system are e (error between the set-point value

and measured value can be observed in Appendix D) and ec (change of e). The outputs are the $\Delta kp, \Delta ki$ and Δkd (the value change of PID parameters). Since Δ can not be typed in the software the kp, ki and kd are typed in to represent $\Delta kp, \Delta ki$ and Δkd and it has to be cleared to avoid any misunderstanding.

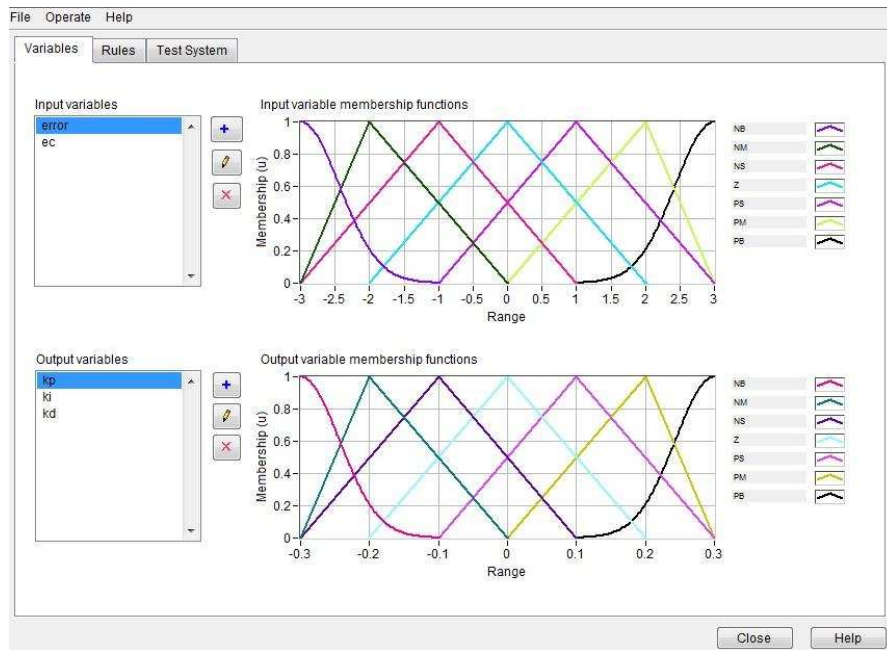

Figure 5-10 Membership functions of error and kp

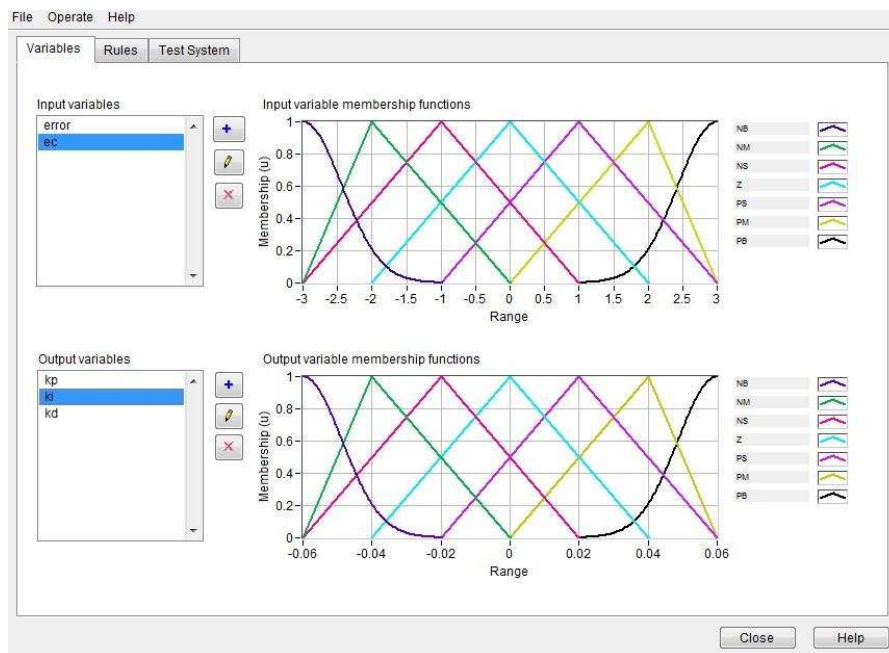

Figure 5-11 Membership functions of ec and ki

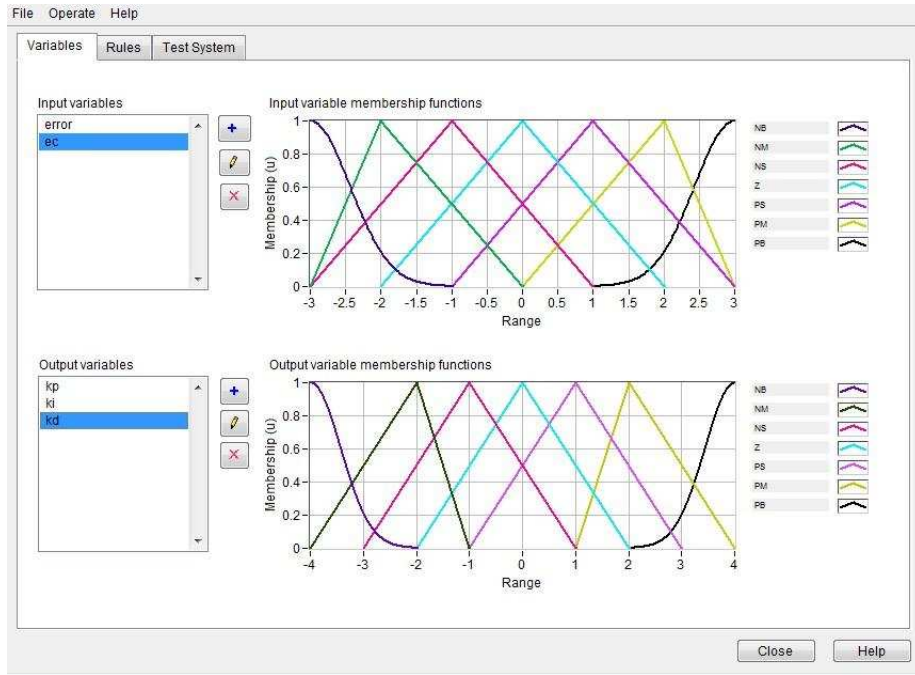

Figure 5-12 Membership function of kd

The rule base design of the fuzzy system is shown in Figure 5-13 and there are 49 rules designed. For example, rule 32: when the fuzzy values of e and ec are PS and Z, the fuzzy value of kp is NS, which of ki is PS and that of kd is Z.

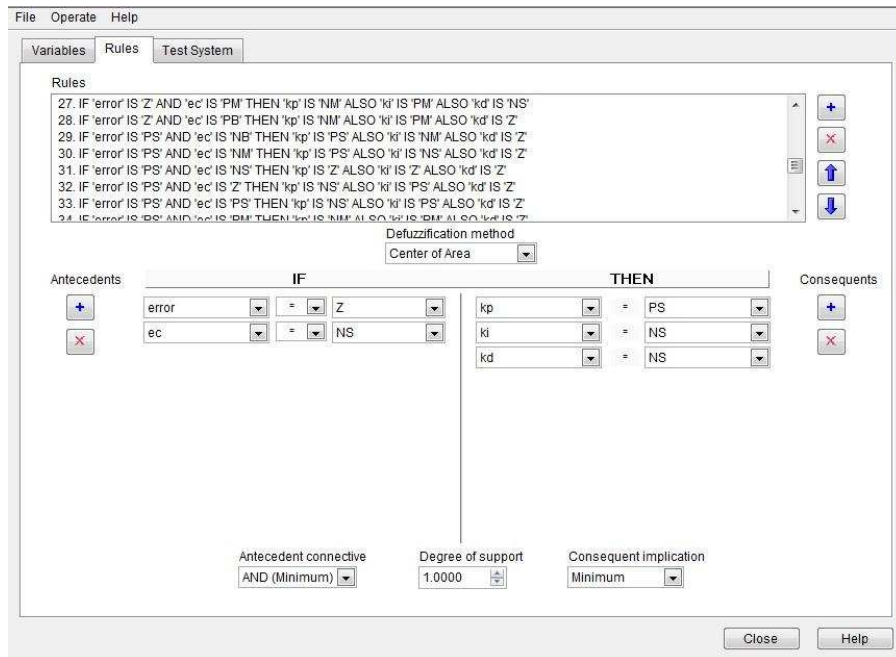

Figure 5-13 Fuzzy rule base

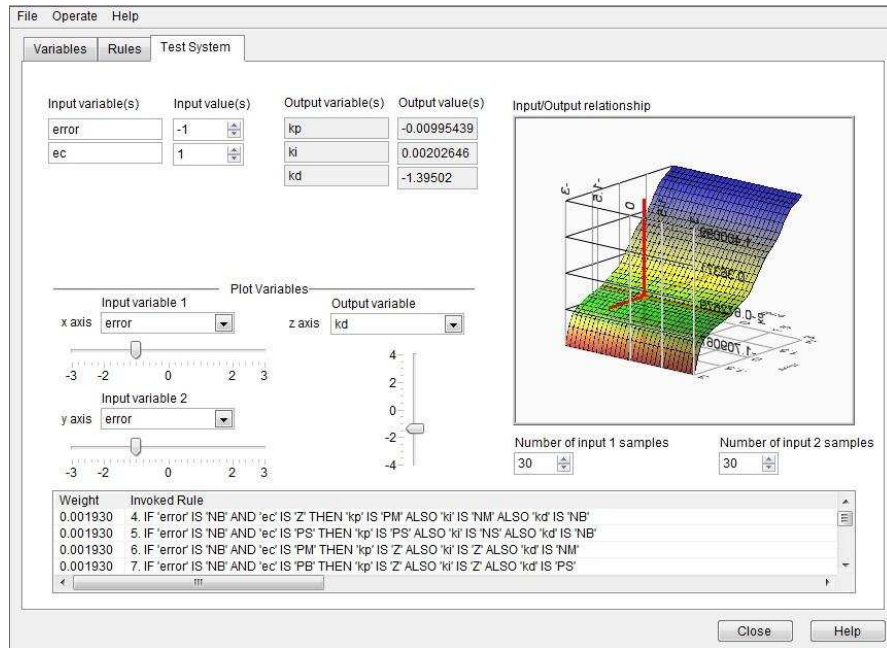

Figure 5-14 Test of fuzzy system

Then the developed system can be tested as shown in Figure 5-14. It shows when the actual value of e and ec are -1 and 1 after the fuzzy calculation process including fuzzification of inputs, getting outputs using the fuzzy rules and defuzzification of outputs, the results $\Delta kp = -0.01$, $\Delta ki = 0.02$ and $\Delta kd = -1.40$ can be obtained. In Figure 5-14, it also shows the input/output relationship. The x axis and y axis are inputs e and ec and the z axis is the output kd .

Then load the load the designed fuzzy system using the fuzzy system load virtual instruments (VI) as shown in Figure 5-15. After loading the fuzzy system, modifications can be made and saved in the front panel of the fuzzy system load VI as shown in Figure 5-16. On the left top part of Figure 5-16, the designed fuzzy system file can be chosen and loaded. On the right part, the information of the input variables, output variables and the fuzzy rules are presented and can be modified and changed.

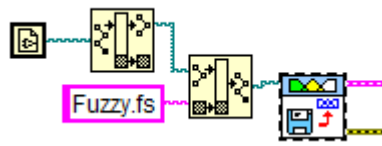

Figure 5-15 Fuzzy system load VI

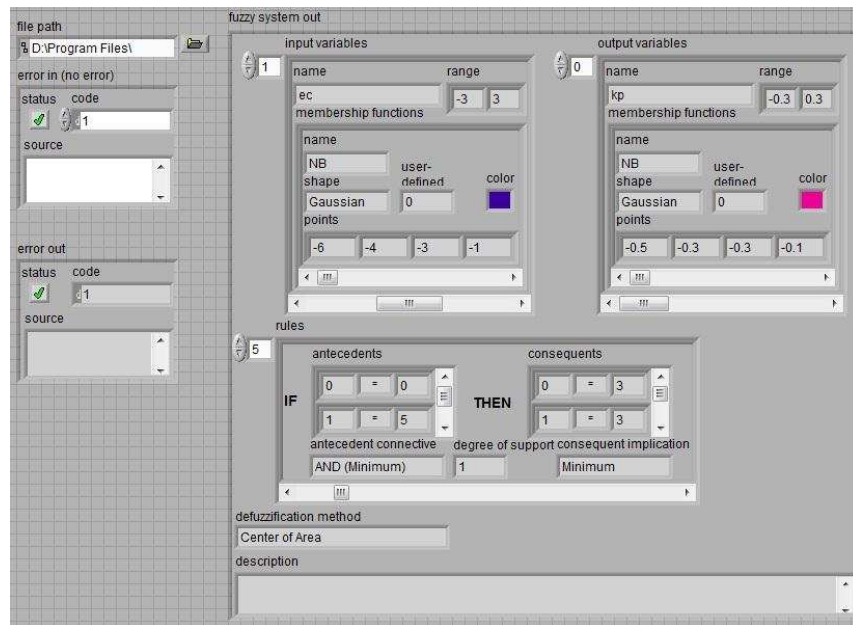

Figure 5-16 Front panel of fuzzy system load VI

The next step is to implement a multiple input multiple output (MIMO) fuzzy logic controller for the designed fuzzy logic system as shown in Figure 5-17. The information of the introduced fuzzy system is transmitted to the MIMO fuzzy controller and its program is shown in Figure 5-18. As the full information of the fuzzy system is loaded to the fuzzy logic controller, the outputs can be obtained based on the inputs and fuzzy information. As presented in Figure 5-18, firstly, the inputs e and ec are fuzzified by their membership function and their fuzzy values are obtained. Then the fuzzy values of the outputs are determined by the fuzzy rules. Finally the outputs are defuzzified by their membership functions and the Δkp , Δki and Δkd values are obtained.

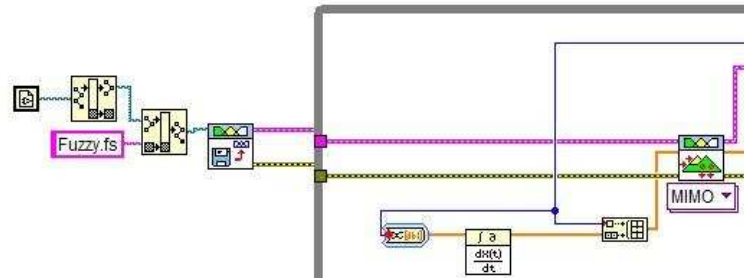

Figure 5-17 MIMO fuzzy controller

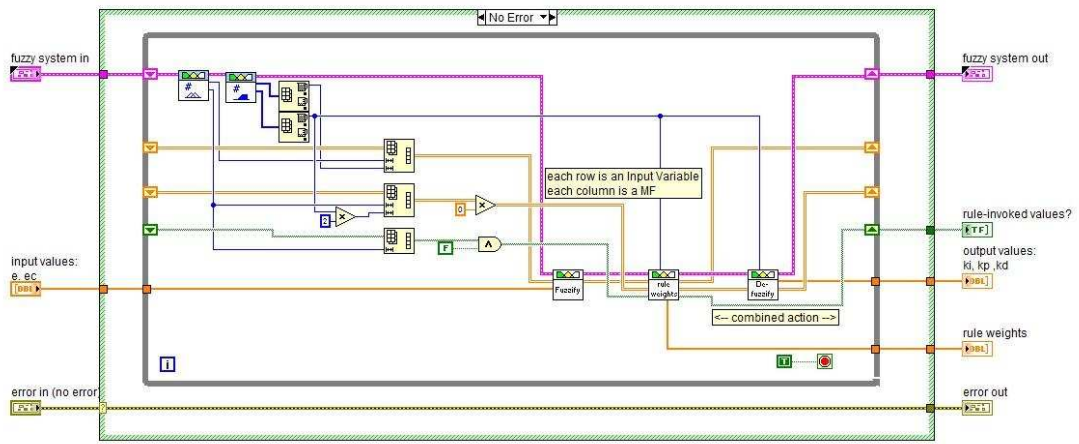

Figure 5-18 Program diagram of fuzzy controller

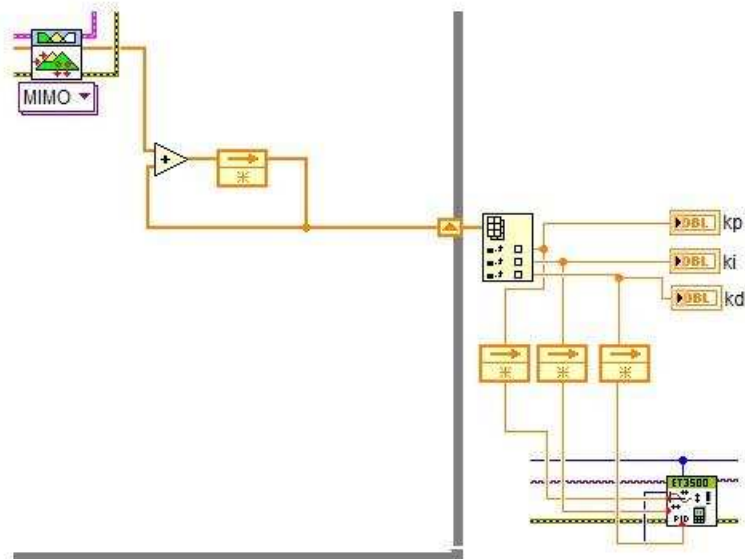

Figure 5-19 Program of sending k_p , k_i and k_d to the PID controller

Using the equations: $kp = kp + \Delta kp$, $ki = ki + \Delta ki$, and $kd = kd + \Delta kd$ and the values of the PID parameters can be calculated. Then the PID parameters are provided to the Eurotherm PID controller for improving the performance and indoor climate quality as shown in Figure 5-20. Hence, the novel indoor climate quality control strategy based on PID control and fuzzy logic control technology is proposed and used in the experiments in this research. The full program diagrams of the fuzzy logic controller and the fuzzy based PID controller are presented in Appendix D. The PID program can be used to control the Eurotherm 3504 PID controller for the temperature, humidity and CO₂ control. The fuzzy logic controller is used to automatically tune the PID parameters and in this way, the proposed fuzzy PID controller is investigated by the experiments. The experimental results are presented and analysed in the following sections.

5.3 Temperature control

The experiments are carried out in the introduced test rig during and using the program introduced in Section 5.2 the period from Oct-2012 to Mar-2013. When the outdoor temperature is low, the chamber needs to be warmed. Hence, in the temperature tests:

- the environment chamber (shown in Section 5.1) is used to simulate the air-conditioned zone;
- the thermal couple (see Figure 5-4) is used to measure the indoor temperature;
- the heater is used to heat the air to certain temperature and which is supplied to the indoor space through the air duct;
- the heater's working power is controlled by the fuzzy-PID controller;
- the set-point of indoor temperature is chosen to be 21°C which is a middle value of comfortable temperature in the period when the outdoor temperature is under

10°C according to ASHRAE 55-2010 [311];

- the working hour (when the office is occupied) is selected between 9:30 to 19:00.

In order to simulate any conditions that this controller may encounter in real buildings, the following adjustments were taken:

- The starting temperatures are different based on the outdoor temperature.
- The door and windows (the door of chamber is used to simulate the door and windows of office) are open in different frequency as people may open the windows and walk in or out the office through the door.

The measurements as shown in Figure 5-20 indicate that it takes about from fifty to seventy minutes to bring the controlled zone's to the set-point from various starting temperature values by the proposed fuzzy-PID controller. It becomes shorter if the starting temperature is higher and the air-conditioned zone is sealed well (door and windows are not open). If the starting temperature is lower and the door and windows are frequently open, the controller takes longer time to get the chamber's temperature to the set point. All measurements indicate that the controller did not take more than sixty minutes to bring the indoor temperature up to 19°C which is within the 80% satisfaction bandwidth according to ASHRAE 55-2010 [311] in any conditions (the condition that the door and windows are open all the time is not considered in our experiments since it is unlikely to happen). Hence, the fuzzy-PID control is started to control and operate the heater at 8:30 when is one hour before the selected working hours in our experiments.

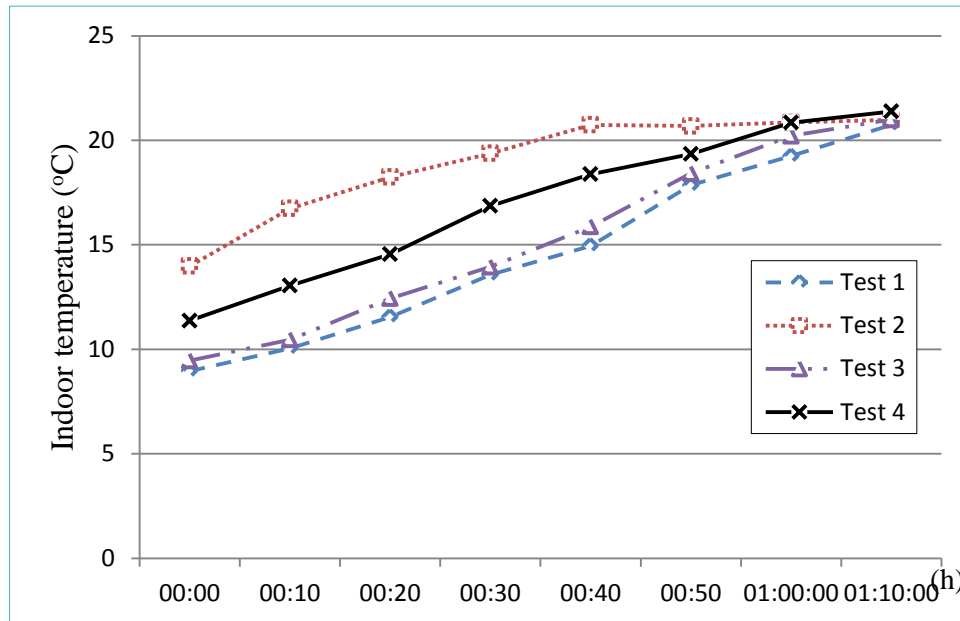

Figure 5-20 Indoor temperature measurement

Figure 5-21 presents the measurement of indoor temperature change in one working day in October 2012. The starting temperature is about 14°C and it can be seen that the indoor temperature is quickly raised to the set-point with heating. During the working hours from 9:30 to 19:00 the indoor temperature is generally kept between 20°C and 21°C. It can be observed that the curve of indoor temperature is relative stable and there is no sharp change during the working hours. This means that the indoor temperature is well controlled by the proposed fuzzy-PID controller.

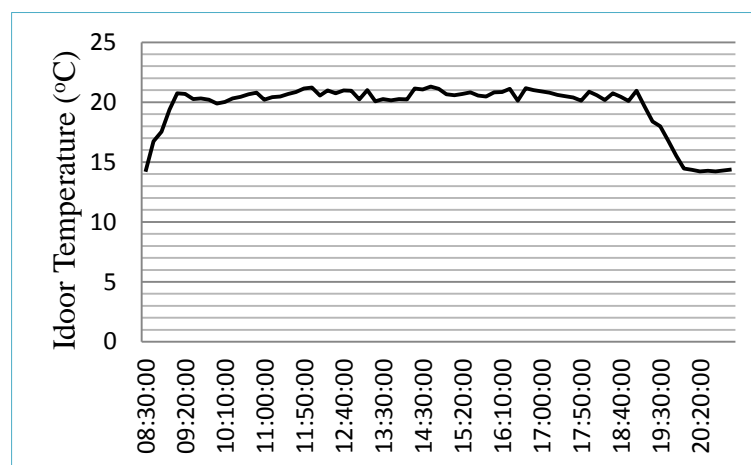

Figure 5-21 Indoor temperature monitored in Oct-2012

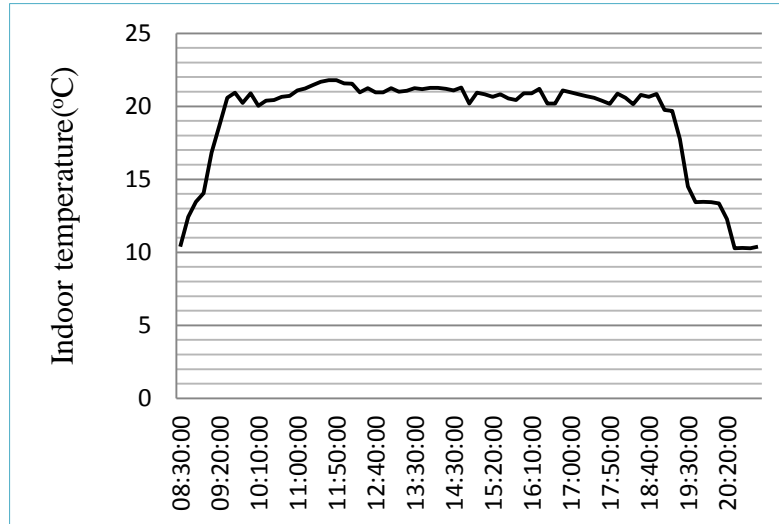

Figure 5-22 Indoor temperature monitored in Nov-2012

Figure 5-22 presents the measurement of indoor temperature variation in one working day in November 2012. The starting indoor temperature is about 10°C as the outdoor temperature is lower than that in October. The system starts at 8:30 and the indoor temperature is raised fast and brought to set-point at first. Then indoor temperature is varying around 21°C during working hours and there is no big overshoot and sharp change. This means the controller has good control accuracy and adaptability.

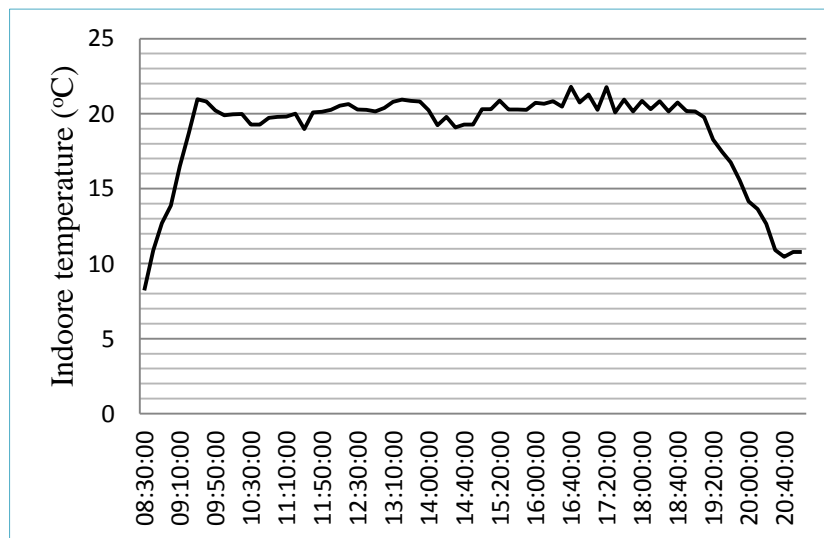

Figure 5-23 Indoor temperature monitored in Dec-2012

Figure 5-23 presents the measurement of indoor temperature variation in one working day in December 2012. The starting indoor temperature is about 8°C to simulate December's outdoor temperature. The system starts at 8:30 and the indoor temperature is raised fast and brought to set-point at first. Then the indoor temperature is relative steady and kept around the set-point. However, there are two periods: one between 10:00 and 11:30 and the other one between 14:10 and 14:50 when the indoor temperature is even lower than 20°C and around 19°C. These large temperature fluctuations were due to the windows of the office being open for a while. Even though the indoor temperature is strongly affected by the outdoor cold air, acceptable indoor temperature (that is lower than the set point in this experiment but is within the comfortable bandwidth) is still provided. This shows that the proposed temperature controller is robust and stable to the disturbances.

The indoor temperature variation during one working day in January 2013 is presented in Figure 5-24. The indoor temperature starts at about 9°C and the system starts at 8:30. The curve clearly presents that at the beginning of the control process, the indoor temperature is quickly brought up to about 19°C and then there is a drop which might be caused by opening the windows or the door. Then the indoor temperature is back on track of rising up until reaching the set-point and the indoor temperature is varying around the targeted temperature until 19:00 when the system is shut down.

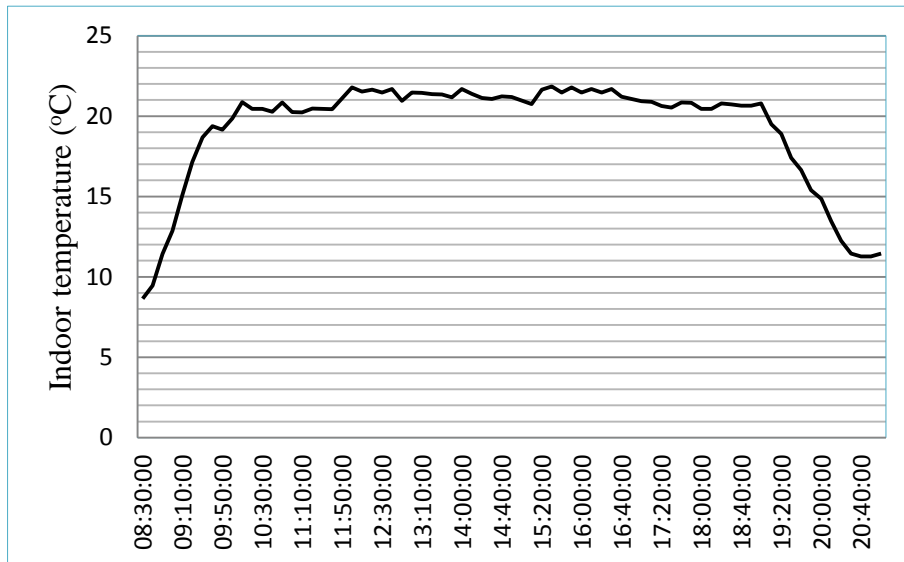

Figure 5-24 Indoor temperature monitored in Jan-2013

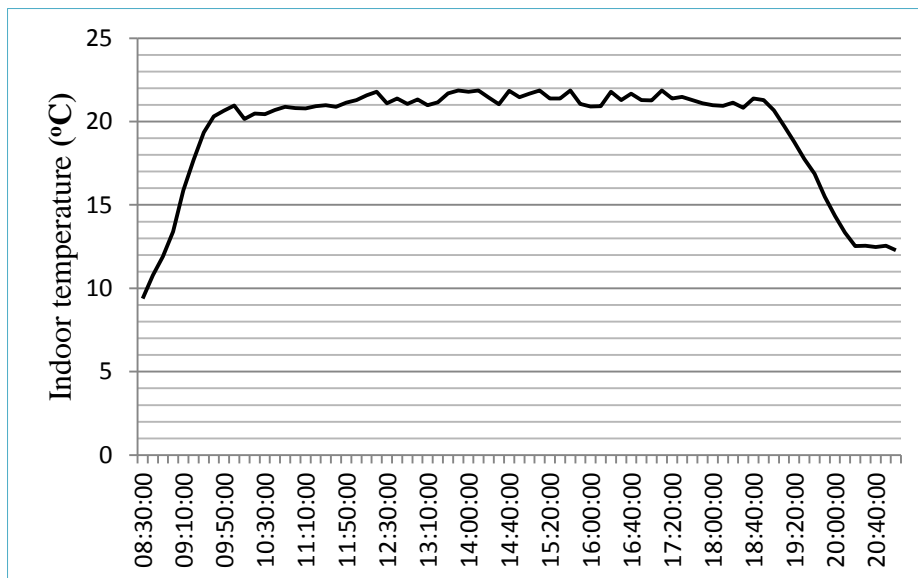

Figure 5-25 Indoor temperature monitored in Feb-2013

Figure 5-25 presents the indoor temperature monitored in one working day in February 2013 and the profile of indoor temperature measurement in one working in March 2013 is shown on the curve in Figure 5-26. Two curves show similar results: during the working period between 9:30 and 19:00 the indoor temperature is kept around the desired temperature. There are some variations due to disturbances but the proposed intelligent temperature controller is able to bring the indoor temperature back to the set-point and there is no unstable condition occurred based on our

observation.

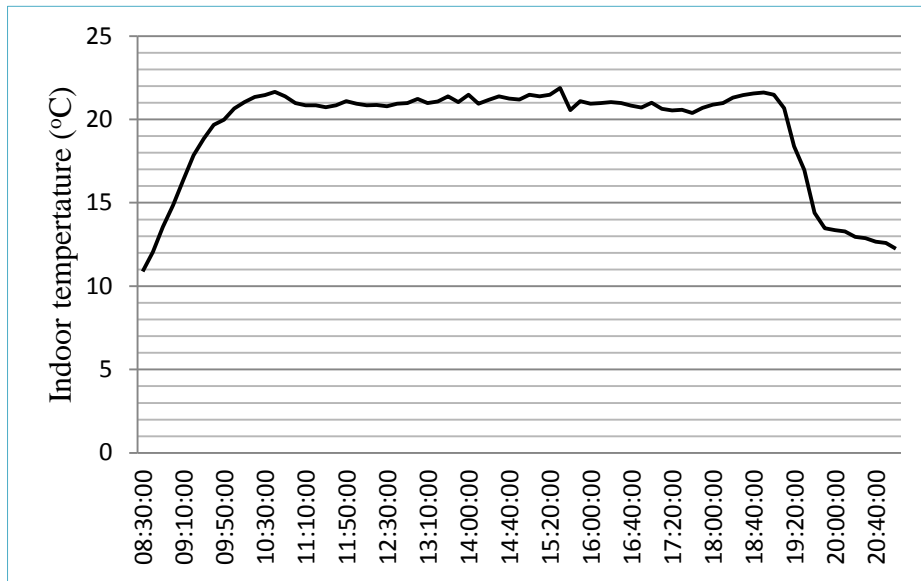
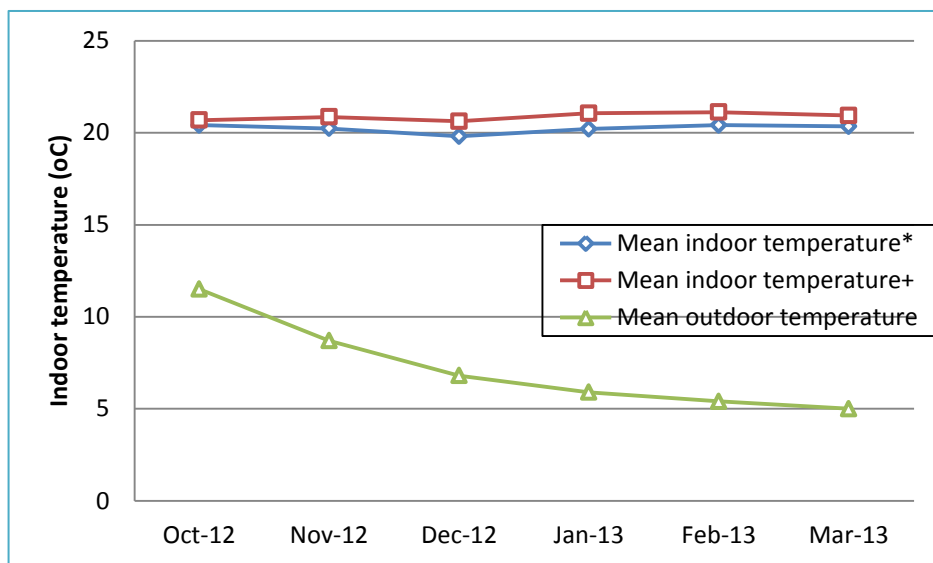

Figure 5-26 Indoor temperature monitored in Mar-2013



*Mean indoor temperature taken during the controller working period

+Mean indoor temperature taken after the controller process enters steady state

Figure 5-27 Monthly mean indoor and outdoor temperature during the experimental period

In Figure 5-27, monthly mean indoor and outdoor temperatures during the experiments period from October 2012 to March 2013 are presented. As it is shown in the figure, the symbol * represents the monthly mean indoor temperature during

the whole control hours between 8:30 and 19:00 and they varies between 19.8°C and 20.4°C. They are about 1°C lower than the desired indoor temperature because at the beginning of control process in each day, the indoor temperature is similar to the outdoor temperature and the average of which is also presented in Figure 5-27. In this figure, the symbol + represents the monthly average of the indoor temperature measured after the control process enters the steady state (that can be considered as starting when the indoor temperature reaches the set-point for the first time). It can be observed that the monthly mean indoor temperatures in steady state are lying between 20.6°C and 21.1°C. The lowest monthly mean indoor temperature is measured in December 2012. The major reason causes such result is that during this month the controller is tested in the conditions that the windows are opened for relative long time or with high frequency. Hence, the mean indoor temperature is affected by the outdoor temperature more easily and is lower than those in other months. Such results prove that the proposed fuzzy-PID temperature controller has good control performance that the steady error is small.

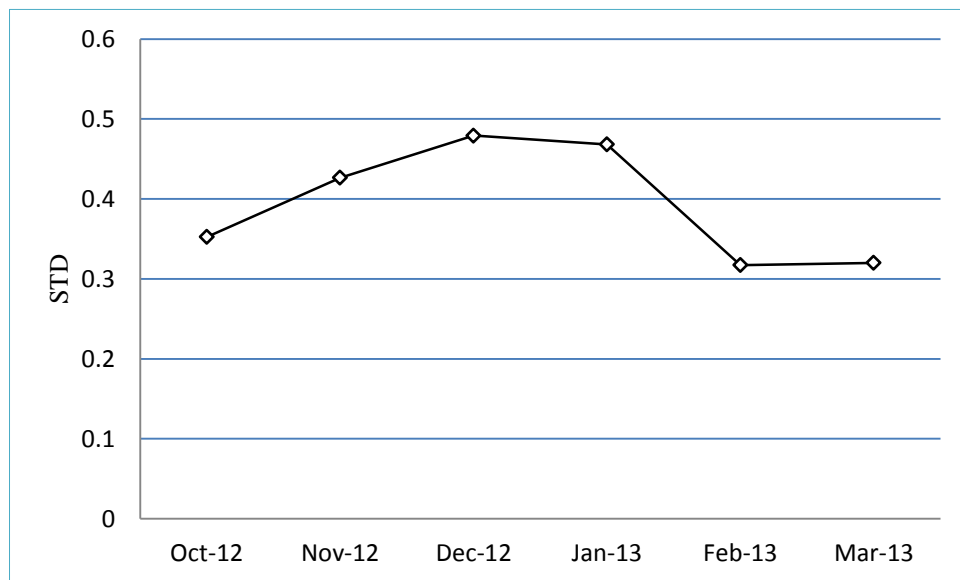

Figure 5-28 Monthly standard deviation of indoor temperature

Besides mean of the collected data as presented in Figure 5-27, another characteristic feature, standard deviation of the measured temperature is calculated to investigate

the proposed temperature controller. The monthly standard deviations of indoor temperature in steady state are presented in Figure 5-28. The highest standard deviation of the indoor temperature is gotten in December 2012 because during this month the controller is tested in the conditions that the windows are opened for relative long time or with high frequency (the same reason that causes lower indoor temperature). Hence, the disturbances occurred in the indoor environment are more often and this leads to higher standard deviation since standard deviation shows how much variation or dispersion from the average exists. Generally, according the results, the monthly standard deviations are all small and this means the controlled indoor temperature data collected in the experiments tend to be very close to the mean and are spread over a small range of values. Therefore, the experimental results show that the fuzzy-PID temperature controller has good control performance of stability and adaptability on indoor temperature control and comfortable indoor temperature can be provide to the air-conditioned zone by the control of the proposed controller.

5.4 Relative humidity

In the experiments, the indoor relative humidity is controlled by the fuzzy logic based PID controller. The experiments are carried out on the test rig introduced in Section 5.1 using the program introduced in Section 5.2. The control performance of the proposed indoor humidity controller is investigated by series of the experiments that are introduced in this section. The experiments are carried out in the test rig during the period from Oct-2012 to Mar-2013 when the outdoor environment is dry and the indoor climate is needed to be humidified. Hence, following preparations should be done for the humidity tests:

- the environment chamber (shown in Section 5.1) is used to simulate the air-conditioned zone;
- the humidity sensor (see Figure 5-5 and Table 5-1) is used to measure the indoor

relative humidity; the output of the sensor is direct current voltage value that can be transferred in to relative humidity value by the give equation as shown in Table 5-1; and in this section, all the profiles of relative humidity are presented in RH(%);

- the humidifier is used to humidify the air to certain humidity level and the air is supplied to the indoor space through the air duct;
- the humidifier's working power is controlled by the control program shown in Section 5.2;
- the recommended indoor relative humidity range is between 30%-60% according to the ASHRAE studies [7]; as it is a wide range and to test the control accuracy, the set-point of indoor relative in this research is chosen to be 55%; and the indoor relative humidity is controlled to be varying between 50% and 60%;
- the working hour (when the office is occupied) is selected between 9:30 to 19:00.

In order to simulate any conditions that might happen in real application of our controller in real buildings, the following work has been done:

- The starting relative humidity in each day is different based on the outdoor environment.
- The door and windows (the door of chamber is used to simulate the door and windows of office) are opened in different frequency as people may open the windows and walk in or out the office through the door. Such activities may introduce disturbances to the control process.

The tests are to investigate the indoor relative humidity rising speed in 2 typical conditions:

- The indoor space is sealed well (windows and door are kept closing).
- The disturbances were introduced to the indoor environment by door and windows being frequently opened (and close).

Based on our measurements, it takes about 60 minutes to 90 minutes to bring the indoor RH to the set-point. It takes shorter to bring indoor relative humidity to the set-point if the starting value is higher and the air-conditioned zone is sealed well (door and windows are not open). On the other hand, it takes longer if the starting relative humidity is lower and the door and windows are frequently open. In addition, all of our measurements prove that control system is able to bring the relative humidity in the medium office area up to 30% which is the lower limit of acceptable relative humidity range within 30 minutes in any conditions (the condition that the door and windows are open all the time is not considered in our experiments since it is unlikely to happen). Therefore, the radial basis function neural network based PID controller is started to control and operate the humidifier at 9:00 when is thirty minutes before the selected working hours in our experiments.

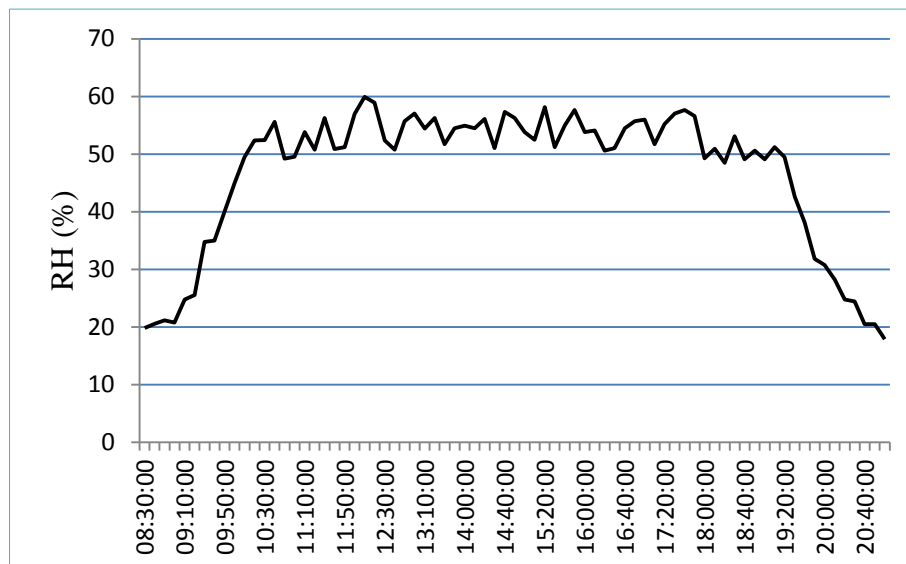

Figure 5-29 Indoor RH monitored in Oct-2012

Figure 5-29 presents the measurement of the indoor relative humidity change in one

working day in October 2012. The starting relative humidity level is about 20% and it can be seen that the indoor relative humidity level is quickly raising upper than 30% and then is brought to the set-point. During the working hours from 9:30 to 19:00 the indoor relative humidity is generally kept between 50% and 60%. It can be observed that the curve of indoor temperature is relative stable and there is no sharp change during the working hours. This means that the indoor relative humidity is well controlled by the proposed humidity controller.

Figure 5-30 presents the measurement of indoor relative humidity variation in one working day in November 2012. The starting indoor temperature is about 19% as the environment is drier. The system starts at 9:00 and the indoor relative humidity is increasing fast and is then brought to set-point at first. Then the indoor relative humidity is relative steady and kept varying within the targeted range. However, there is a period between 15:00 and 16:20 when the indoor relative humidity is varying sharply. Because, during this period, the windows of the office are open for a while and the indoor environment is influenced by the outdoor dry and cold air that the caused the indoor relative humidity level changed frequently and sharply. However, although the disturbances lead to the sharply variation in the humidity control process, there is no unstable state occurred and the indoor relative humidity is varying within the desired range. This shows that the proposed temperature controller has good robustness and stability when the disturbances keep being introduced to the system.

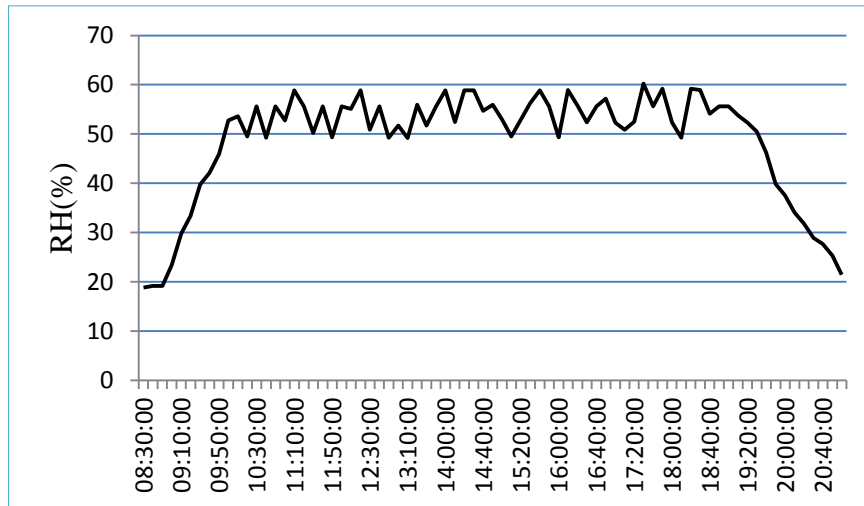

Figure 5-30 Indoor RH monitored in Nov-2012

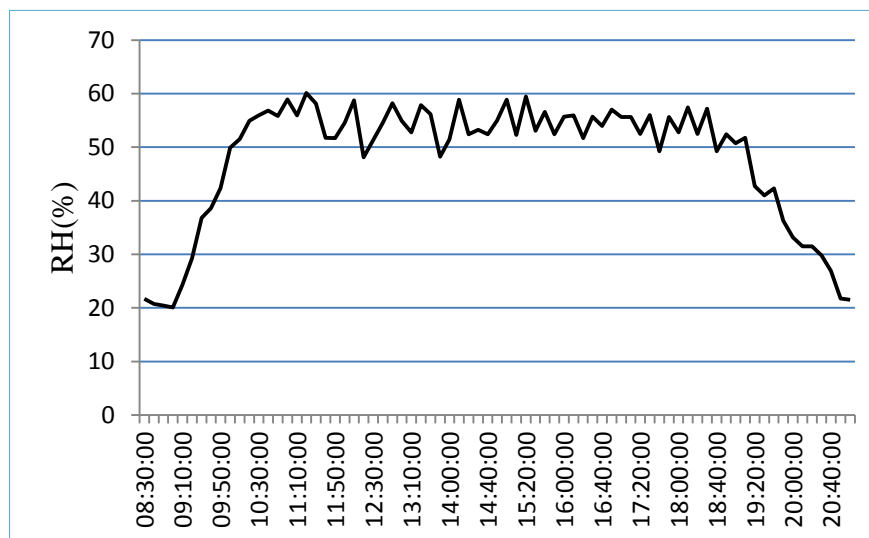

Figure 5-31 Indoor RH monitored in Dec-2012

The indoor relative humidity variation curve based on the experimental test taken in one working day in December 2013 is presented in Figure 5-31. It presents that the indoor relative humidity level is 20% at time 9:00 when the control system starts working. At the beginning of the control process, the relative humidity level keeps increasing towards the desired output. After that the indoor relative humidity is varying within the targeted range. Then it can be observed that the indoor relative humidity level is lower than 50% which is the lower limit of the targeted range at 12:30 and 13:30. The sudden change of the indoor environment caused by windows

opening or temperature change may lead to such results. Then the system quickly reacts to this change and brings the indoor relative humidity back to the desired range. During other time of the working hours, the relative humidity is well controlled.

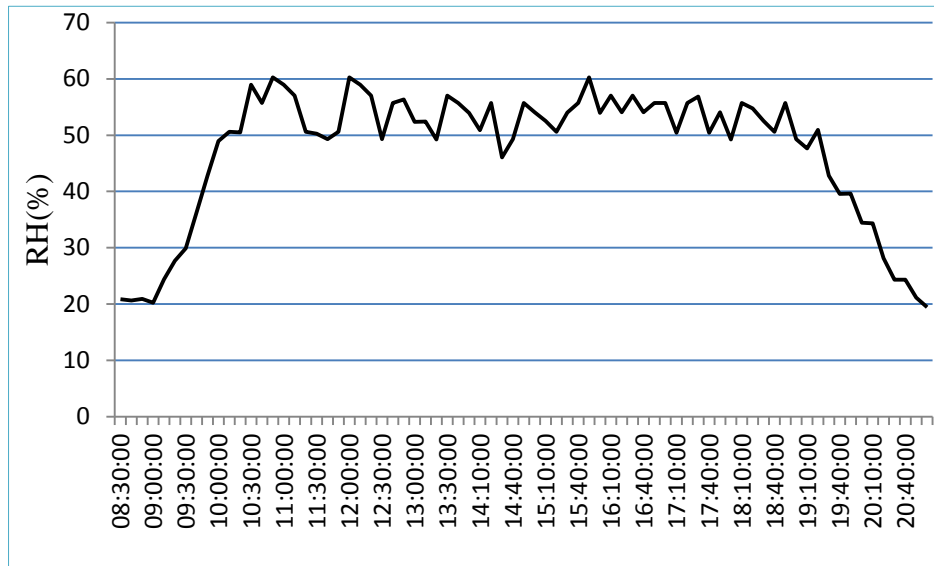

Figure 5-32 Indoor RH monitored in-Jan 2013

Figure 5-32 shows the curve of indoor relative humidity change in one working day in January 2013. In order to test adaptability and stability of the newly designed humidity controller, the disturbances are kept introducing to the indoor environment during the work period in this day. In the experiment, the disturbances are simulated by opening the door of chamber (as the windows and door of the office) and bringing in dry air into the chamber. Hence, the variation in this day is bigger than the previous tests and there is a period the indoor relative humidity is lower than 50%. However, the control performance is acceptable in general since the indoor humidity level is controlled within the targeted range except one period of time. Moreover, in most of the time, the indoor relative humidity is change smoothly and is spread with in a small range. The stable steady state and good adaptability of control process is guaranteed by the novel humidity controller.

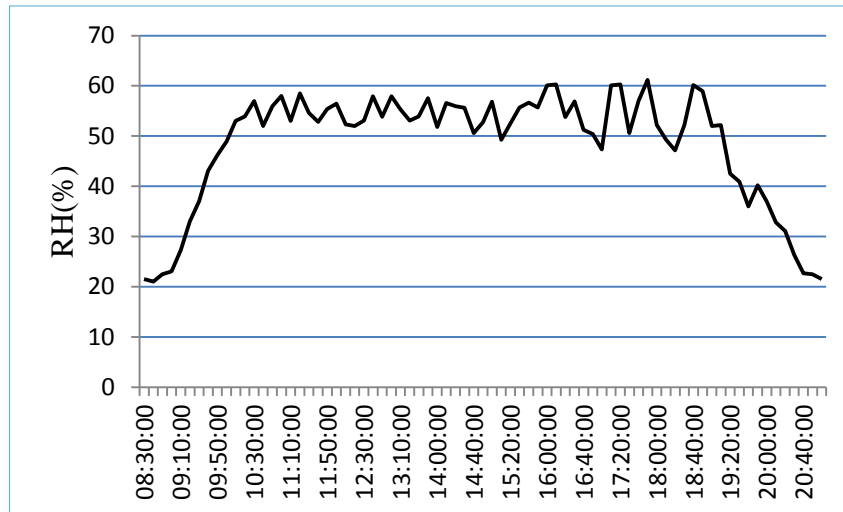

Figure 5-33 Indoor RH monitored in Feb-2013

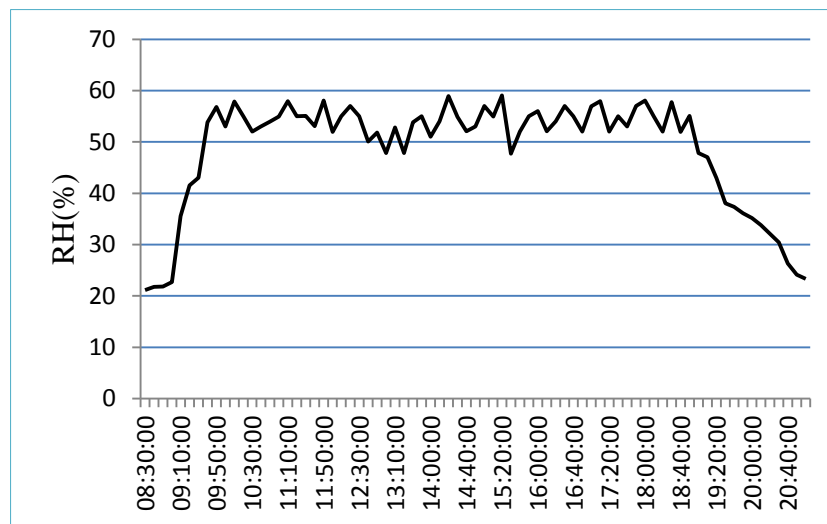
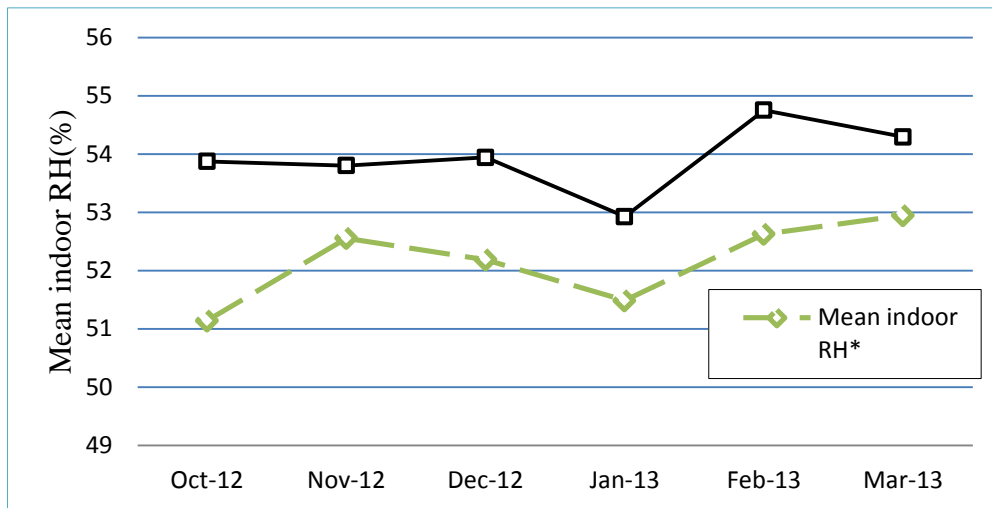

Figure 5-34 Indoor RH monitored in Mar-2013

Figure 5-33 presents the indoor relative humidity monitored in one working day in February 2013 and the profile of indoor relative humidity measurement in one working in March 2013 is shown on the curve in Figure 5-34. Two curves show similar results: during the working period between 9:30 and 19:00 the indoor relative is kept around the desired range. There are some variations due to disturbances but the proposed intelligent humidity controller is able to bring the indoor relative humidity back to the targeted range and there is no unstable condition occurred based on our observation.



*Mean indoor RH taken during the controller working period

+Mean indoor RH taken after the controller process enters steady state

Figure 5-35 Monthly mean indoor humidity

In Figure 5-35, monthly mean indoor relative humidity levels during the experiments period from October 2012 to March 2013 are presented. As it is shown in the figure, the symbol * represents the monthly mean indoor relative humidity during the whole control hours between 9:00 and 19:00 and they varies between 51.1% and 53.0%. They are about 2%-4% lower than the set-point because at the beginning of control process in each day, the indoor relative humidity much lower than the set-point due to the outdoor environment. In this figure, the symbol + represents the monthly average of the indoor relative humidity measured after the control process enters the steady state (that can be considered as starting when the indoor relative humidity level reaches the set-point for the first time). It can be observed that the monthly mean indoor relative humidity levels in steady state are lying between 53.0% and 54.8%. The lowest monthly mean indoor temperature is measured in January 2013. The major reason causes such result is that during this month the controller is tested in the conditions that the windows are opened for relative long time or with high frequency as discussed in previous paragraph. Hence, the mean indoor relative humidity level is affected by the outdoor climate more easily and is lower than those in other months.

Besides mean of the collected data as presented in Figure 5-35, standard deviation of the measured relative humidity level is calculated to investigate the proposed temperature controller. The monthly standard deviations of indoor relative humidity level in steady state are presented in Figure 5-36. The highest standard deviation of the indoor temperature is gotten in October 2012 and January 2013 because during these months the controller is tested in the conditions that the windows are opened for relative long time or with high frequency (the same reason that causes lower indoor temperature). Hence, the disturbances occurred in the indoor environment are more often and this leads to higher standard deviation since standard deviation shows how much variation or dispersion from the average exists. Generally, according the results, the monthly standard deviations are all small and this means the controlled indoor relative humidity data collected in the experiments tend to be very close to the mean and are spread over a small range of values. Therefore, the experimental results show that the RFBNN-PID humidity controller has good control performance of stability and adaptability on indoor humidity control and comfortable indoor environment can be provided to the air-conditioned zone by the control of the proposed controller.

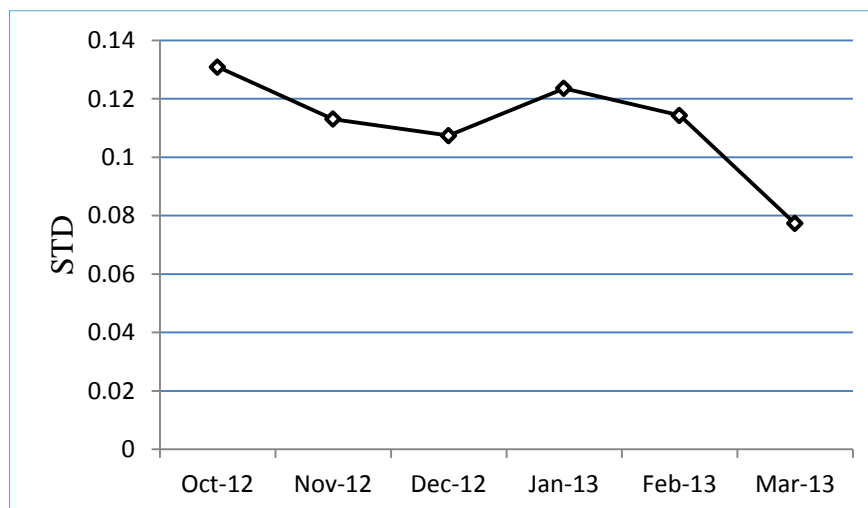

Figure 5-36 Stand deviation of indoor relative humidity

5.5 Carbon dioxide concentration

Indoor air quality improvement using advanced control method is investigated by experiments in laboratory. As it introduced in Chapter 1, during the experimental work, the indoor CO₂ concentration is controlled by the fuzzy logic controller. The experiments are carried out in the test rig by using the introduced program during the period from Oct-2012 to Mar-2013. The outdoor CO₂ level is about 300ppm - 400ppm and preparations of the CO₂ tests are as follows:

- the environment chamber (shown in Section 5.1) is used to simulate the air-conditioned zone;
- the carbon dioxide monitoring module (see Figure 5-6 and Table 5-2) is used to measure the indoor CO₂ concentration; the measured value is voltage that can be transferred into ppm according to the voltage-ppm relation shown in Table 5-2.
- the fan is used to bring the fresh air into indoor space through the air duct;
- the working power (speed) of the fan is controlled by the proposed fuzzy-PID controller in experiments;
- the CO₂ concentration in this project is kept below 1,000 ppm which is suggested as the upper limit of healthy indoor CO₂ level [7]; some studies prefer 650 ppm but that set-point may require the ventilation system working all the time;
- the working hour (when the office is occupied) is selected between 9:30 to 19:00.

The chamber is used to test the controller for CO₂ control. In order to simulate any conditions that might happen in real implement of our controller in real buildings, the following conditions has been simulated:

- The door and windows (the door of chamber is used to simulate the door and windows of office) are opened in different frequency as people may open the windows and walk in or out the office through the door.
- The office is unoccupied sometimes, for example people working in the office may go for lunch. To simulate this condition, people would leave the laboratory and make sure no one is near to the chamber.
- The occupancy level may increase and be higher than normal for a while, for example people from other places may enter this office for work or business.
- People may come to work earlier or later than regular schedule.
- People may leave earlier or later than regular schedule.

The CO₂ is known as a type of occupant-related indoor air pollutant and it is only generated by human beings in an office area. Hence, when the air-conditioned space is unoccupied there is no CO₂ generated. This means that the indoor CO₂ level should be the same or similar as the outdoor CO₂ level at the beginning of each day. Then when people come to work and the office is reoccupied the CO₂ starts to increase mainly based on the indoor occupancy level. As the indoor CO₂ level is moving towards the CO₂ set-point the fan will start working to bring fresh air into the indoor environment in order to keep the indoor CO₂ at acceptable level. Thus, in the experimental tests, the control system does not need to be triggered before the working period (9:30 in the morning). The controller will decide when to turn on the ventilation based on its algorithm.

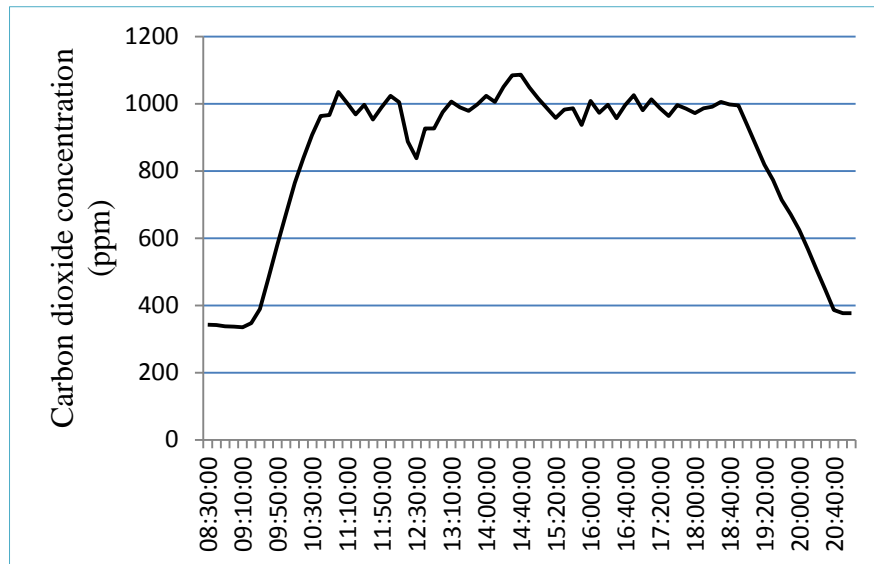

Figure 5-37 Indoor CO₂ level monitored in Oct-2012

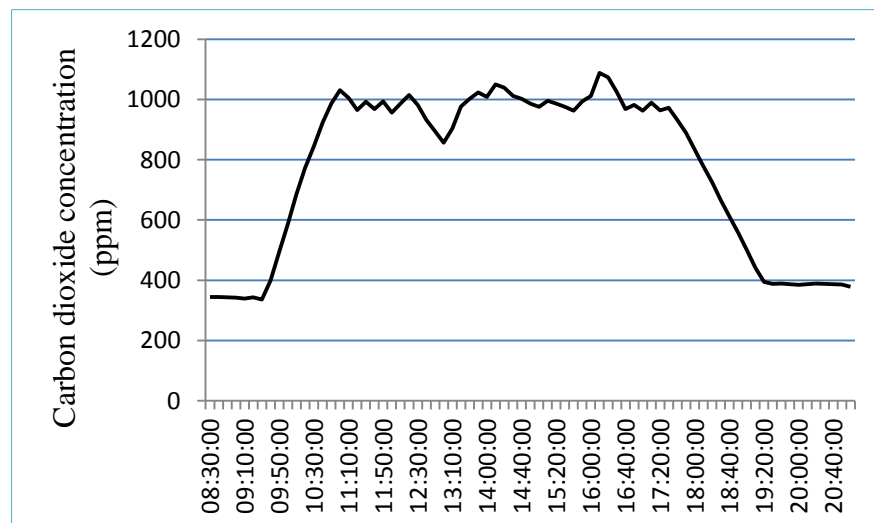

Figure 5-38 Indoor CO₂ level monitored in Nov-2012

The indoor CO₂ level variation during one working day in October 2012 is presented in Figure 5-37. The test was carried out in the experimental chamber. It can be observed that at the beginning of the day the indoor CO₂ level is 343ppm that is similar to the outdoor CO₂ level. Then, starting at 9:30 the indoor CO₂ concentration is increasing rapidly as there are people working in the indoor space based on the regular schedule. To simulate this condition, the researcher would start breathing into the chamber. The rising speed of CO₂ concentration starts to slow down after it reaches 840ppm in this experiment. This means the fan is switched on by the control

command and fresh air is supplied in to the office area (chamber). Then the curve of CO₂ is varying around 1000ppm within small range. Then, people leave the office at 12:10. In this case, make sure no one is near to the experimental chamber. As a result the indoor CO₂ begins to decrease and is brought down to 838ppm at 12:30. In the following period, the CO₂ level begins to increase again as people come back to the monitored room. Then between 14:00 and 14:50, the condition that people from other place enter this office area and stay for a relative long period is introduced to the control process. Since the occupancy level is higher than regular the indoor CO₂ level keeps increasing and being higher than the set-point. In order to simulate the condition that the occupancy level is higher than regular, researcher would breathe into the chamber in higher frequency or breathe directly to the CO₂ sensor. But this situation does not last for long as the novel indoor air quality controller learns the situation and modifies the control parameter and then, the CO₂ level starts to decrease before people leaving. After people leave the office, the CO₂ level is brought down to the set-point.

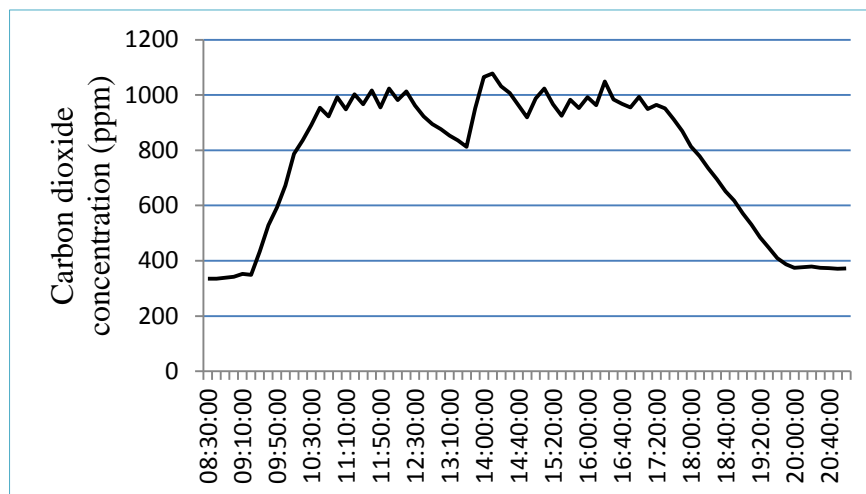

Figure 5-39 Indoor CO₂ level monitored in Dec-2012

The profile of indoor CO₂ variation based on the control of the proposed controller in one working day in November 2012 is presented in Figure 5-38 and Figure 5-39 shows the CO₂ change in December 2012. The figures show similar results as that of

the experiment in October. The CO₂ level starts to increase at 9:30 when people come to work and then varies spread in small range near the set-point. During the lunch break time, the CO₂ level keeps dropping as there is no person in the air-conditioned space. In addition, there is a period in each day when the indoor occupancy is higher than normal. At the beginning of this period, the indoor CO₂ maintains high level but later the controller is able to bring the indoor CO₂ level back to the right track and people are not exploring in the undesired environment for long. Moreover, the condition that people leaving the office at about 17:00 that is much earlier than the schedule time is simulated in the experimental test. Results show that the CO₂ level starts decreasing when people leave and the dropping speed is fast at first because of the ventilation and then slower. It means no over ventilation is occurred.

The indoor CO₂ concentration observation of one working day in January 2013 and another in February 2013 are shown in Figure 5-40 and Figure 5-41. Similar results are collected that the CO₂ concentration begins to increase at about 10:10 in the morning since the air-conditioned zone is occupied later than usual. During the whole working hours, the indoor CO₂ level is controlled well lying within the acceptable range near 1000ppm and there is not any unstable situation occurred.

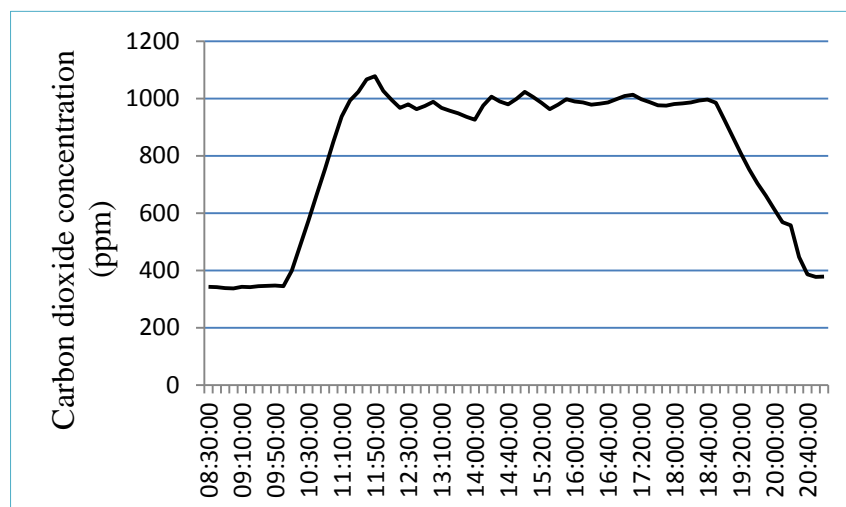

Figure 5-40 Indoor CO₂ level monitored in Jan-2013

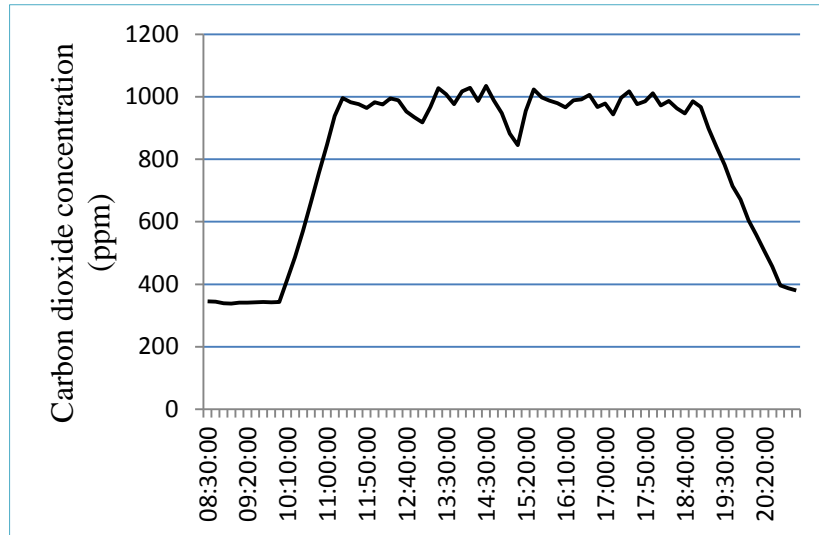

Figure 5-41 Indoor CO₂ level monitored in Feb-2013

The curve in Figure 5-42 represents the variation of indoor CO₂ concentration in one working day in March 2013. Different from the previous four experiments, the occupied period is based on the regular schedule from 9:30 to 19:00 and there is a lunch break between 14:00 and 14:30. The experimental results prove that the proposed indoor air quality controller is able to provide the acceptable indoor air quality by keeping CO₂ concentration at acceptable level.

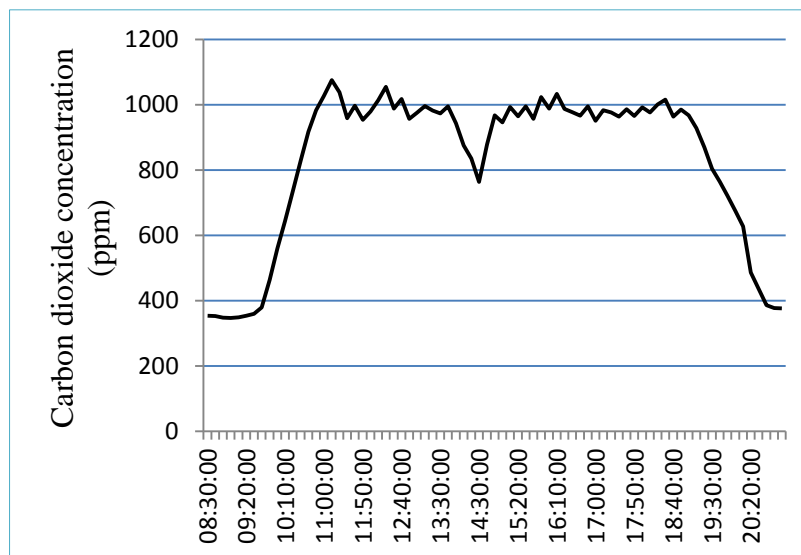
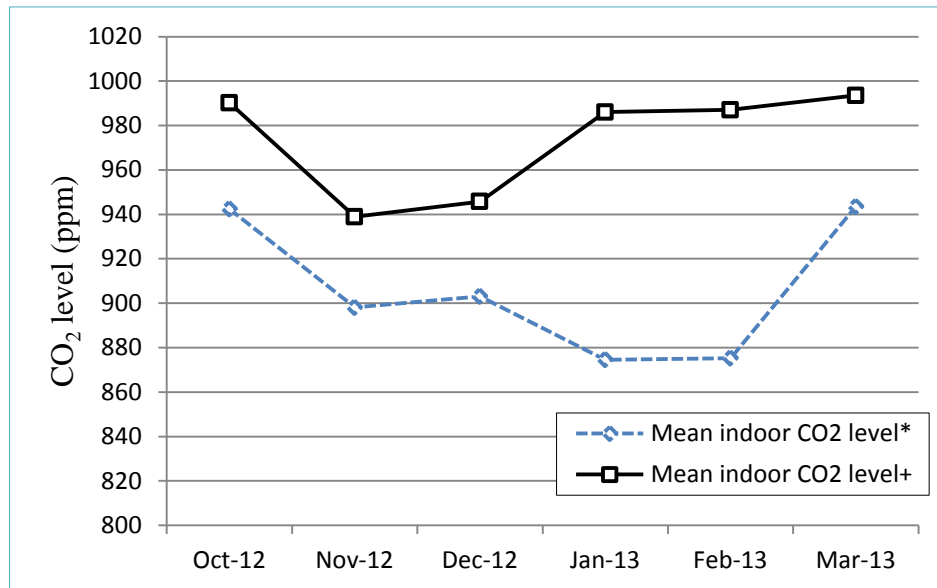

Figure 5-42 Indoor CO₂ level monitored in Mar-2013



*Mean indoor CO₂ level taken during the scheduled occupied period

+Mean indoor CO₂ level taken during the actual occupied period

Figure 5-43 Mean indoor CO₂ level

In Figure 5-43, monthly mean indoor CO₂ levels during the experiments period from October 2012 to March 2013 are presented. As it is shown in the figure, the symbol * represents the monthly mean indoor CO₂ level during the scheduled occupied hours between 9:30 to 19:00 and they varies between 875ppm and 944ppm. They are about 125ppmm to 60ppm lower than the set-point because at the beginning of control process in each day, the indoor CO₂ much lower than the set-point due to the outdoor environment. In this figure, the symbol + represents the monthly average of the indoor CO₂ measured after the control process enters the steady state (that can be considered as starting when the indoor CO₂ level reaches the set-point for the first time). It can be observed that the monthly mean indoor relative humidity levels in steady state are lying between 939ppm and 994ppm. Hence, the indoor CO₂ concentrate is kept at acceptable level and the small steady error could also mean that no over ventilation is caused during the controller working hours.

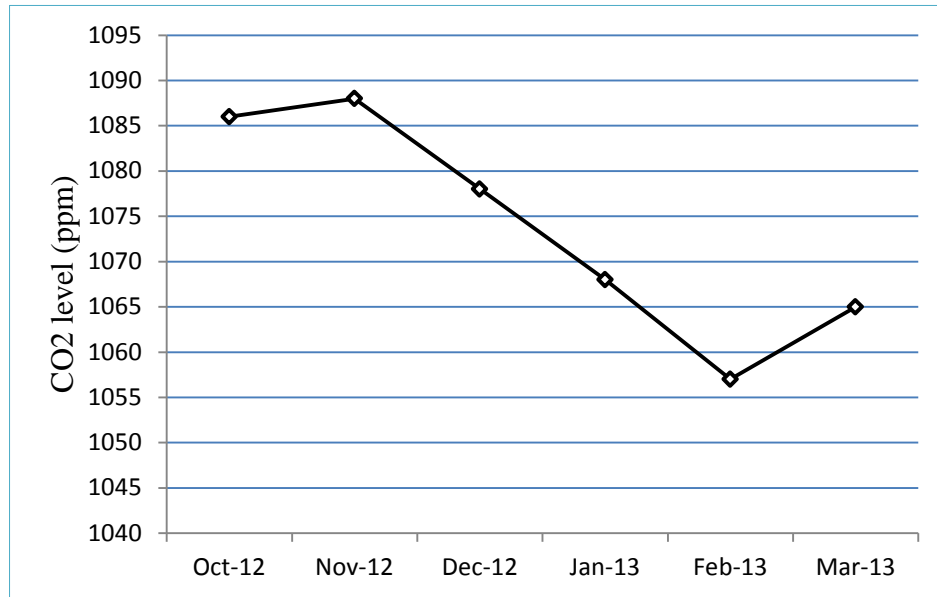

Figure 5-44 Maximum indoor CO₂ level

Moreover, different from temperature and relative humidity that are needed to be controlled within a range, the indoor CO₂ level is needed to be control under a certain level. Hence, when the windows are open or the air-conditioned zone is unoccupied, the indoor CO₂ level goes down and in this case the indoor CO₂ can be a lot lower than the set-point. For this reason, the values of indoor CO₂ concentration are spread in a relative range and the standard deviation is not suitable to understand the performance of indoor air quality controller. Therefore, maximum is used to investigate the proposed temperature controller. The monthly maximum values of indoor CO₂ level in steady state are presented in Figure 5-44. Generally, according the results, the biggest maximum value in each day is 1088ppm which is not harmful to human body if such level does not maintain for long period.

5.6 Summary

In this chapter, the experimental investigation has been carried out to test the performance of the fuzzy-PID controllers for indoor temperature control, indoor humidity control and indoor CO₂ level control. In the experimental investigation, the controlled indoor space is an environmental chamber used to simulate a medium

office area for four to six people; the control signals are: temperature, relative humidity CO₂.

In order to get more accurate results, the experimental tests were carried out over a wide range of period for October 2012 to March 2013. The selection of this period is that in the summer season, indoor temperature is within the thermal comfort bandwidth according to ASRHAE [311]; therefore, the control for this period is not necessary. During the environments period the indoor environment is needed to be heated and humidified and ventilation is also needed when indoor space is occupied. For this reason, this is good timing to investigate the performance of the introduced controllers. The experiments are carried out in working days and the scheduled working hours are chosen as between 9:30 and 19:00.

The experimental tests are carried out on the test rig as shown in Figure 5-1. The main part of the test rig is an environmental chamber as shown in Figure 5-2 used to simulate the indoor office area. Three types of sensors: thermal couple, humidity sensor and CO₂ sensor are installed inside the chamber. Then, designed control program of the three novel controllers will be used to analyse the collected signals and other relative information. The control command will be sent to the air-conditioning devices: heater, humidifier and fans through the controller and drives. Finally, the indoor climate is changed by the work of the air-conditioning devices. As the control circle keeps running, the indoor environment quality is modified according to the desired requirements and the experimental results are concluded in this section.

Temperature

The tests of indoor temperature control are carried out through the period from October 2012 to March 2013. In this thesis, the temperature measurements from six working days, one from each month are drawn in curves as shown in Section 5.2.

Moreover, the characteristic features: mean and standard deviation of the collected data are calculated to help to analyse controller's performance. The results show that:

- At the beginning of each day when the indoor temperature is generally 10°C to 15°C lower than the set-point, the controller is able to bring the indoor temperature to the desired level rapidly. Hence, the indoor temperature is well controlled during this time. The controller is proved to have fast rising speed and small overshoot.
- When the control process enters the steady state, the indoor temperature settles, stays relative stable and varies without big and sharp change.
- The monthly mean temperature as presented in Figure 5-27 shows the controller has small steady error that control accuracy can be guaranteed. The maximum error percentage is 9.4% and average control accuracy is 4.4%.
- When there are disturbances (opening the windows or door that causes the indoor condition suddenly changed) introduced to the indoor environment, the response of the controller to the disturbances is quick and there is no unstable situation occurred. This proves the fuzzy logic control rule has excellent performance on enhancing the PID temperature control.
- The standard deviation as shown in Figure 5-28 prove that the indoor temperature is controlled to be varying close to the set-point and spread over small range. This result shows that the control has excellent stability and adaptability. Hence, the indoor temperature can be well controlled in any situations.

Humidity

Indoor relative humidity is investigated by the experimental tests taken between October 2013 to March 2013 when then indoor environment needs to be humidified.

The profiles of the indoor relative humidity variation in six working days one in each month are presented in Section 5.3. Moreover, the characteristic features: mean and standard deviation of the collected data are calculated. They can help to analyse controller's performance. The results show that:

- At the beginning of each day, the indoor relative humidity is about 30% lower than the set-point range. The controller is able to raise the indoor relative humidity to the desired level rapidly. Hence, the indoor relative humidity is well controlled during this time.
- When the control process enters the steady state, the indoor relative humidity is brought towards the set-point. Then it varies around the set-point without big and sharp change.
- The monthly mean relative humidity as presented in Figure 5-35 shows that mean values are all very close the set-point. Hence, the controller has small steady error that control accuracy can be guaranteed. The control accuracy is about 3.2%
- The situations that the disturbances (opening the windows or door that causes the indoor condition suddenly changed) introduced to the indoor environment are simulated. Response of the controller to the disturbances is quick and there is no unstable situation occurred. This proves the neural network algorithm has excellent performance on enhancing the PID humidity control.
- The standard deviation as shown in Figure 5-36 prove that the indoor temperature is controlled to be varying close to the set-point and spread over small range. This result shows that the controller has excellent stability and adaptability. Hence, the indoor relative humidity can be well controlled in any situations.

CO₂

In this thesis, the data of indoor CO₂ change collected in six working days, one in each month (October 2012 ~ March 2013) are presented in Section 5.3. Moreover, the characteristic features: mean and maximum of the collected data are calculated to help to analyse controller's performance. The results show that:

- At the beginning of each day, when the CO₂ level is increasing towards 1000ppm, the controller starts to control the fan to supply fresh air into the indoor zone. Results show that the CO₂ is well controlled during this period.
- When the control process enters the steady state, the indoor CO₂ is varies around the set-point without big and sharp change. This shows the controller has good performance of stability.
- The monthly mean CO₂ level as presented in Figure 5-43 shows that mean values are all very close the set-point.
- The maximum CO₂ levels in each month are shown in Figure 5-44 and the biggest maximum value is under 1100 ppm which means the CO₂ concentration is kept within the acceptable level.
- These two characteristic features show that the indoor air quality is maintained well when there is no over ventilation.
- When the situation that the indoor occupancy level suddenly increases, the controller is able to quickly modify its control parameters. The results show that the CO₂ level is well under control and there is no poor air quality provided.
- When the occupancy level suddenly decreases, the controller also quickly reacts to the situation and there is no over ventilation occurred.

Chapter 6 Discussion, conclusion and future work

6.1 Discussion

In this section, the performance of the proposed controllers is firstly discussed based on the theoretical analysis, simulating test and experimental investigation. Then, the improvement of indoor climate because of the novel controllers is described. Finally, the concept of controller design introduced in this thesis for indoor environment quality control development is discussed.

6.1.1 Performance analysis based on theoretical and simulation analysis

Fuzzy-PID

A fuzzy-PID controller is designed for the indoor environment quality control because:

- PID controller is suitable for various control object including indoor climate,
- fuzzy logic control for optimal PID parameters tuning to ensure adaptability to different situations,
- better PID control parameters selection can ensure the desired system output,
- robustness to ensure stability.

In order to optimize its capability of indoor environment quality control before putting into real implement simulating tests are carried out to investigate the controller's performance. In Section 4.1, temperature is used as the control signal to test the fuzzy-PID control performance by simulation. The step input signal is used as the control reference for the test. The simulating results show that proposed intelligent temperature controller may have excellent performance on indoor temperature control as:

- Simulating results show that the optimized k_p , k_i and k_d can be gained based on the system output error (e) and the change of system output error (ec) by the fuzzy rules. The obtained PID parameters are suitable for keeping or bringing the control process to the steady state.
- The robustness shows good control accuracy and there is no overshoot and steady state error.
- Different k_p , k_i and k_d values are obtained in different situations. The time constant is 0.033s and the settling time is 0.092s while the sampling interval is 0.001s.
- Simulate results prove that to apply the fuzzy logic rule to a PID control process can improve the performance of both the PID controller and the fuzzy control itself.

Then the experiment investigation is carried out and the improvement of indoor environment is discussed in next section.

RBFINN-PID

A RBFINN-PID control could be excellent to deal with the humidity control problems.

The indoor humidity can be well control since:

- PID controller is suitable for various control object including indoor humidity control,
- RBF neural network has fast processing speed to ensure that best PID value can be obtained as long as there is indoor climate change, in which way the stability and adaptability of the proposed controller can be guaranteed.
- better PID control parameters selection can ensure the desired system output,

- robustness to ensure stability.

In order to optimize its capability of humidity control before putting into real implement simulating tests are carried out to investigate the controller's performance.

- RBF neural network has fast processing speed and this ensures that the controller quickly reacts to the indoor environment change,
- The regulation of the PID parameters using RBF neural network is a complex mission and the tuning process based on Jacobian information. The k_p , k_i and k_d are kept modifying for the optimised values along with change of Jacobian values in different situations or when disturbances introduced to the control process.
- Simulating results show that the Jacobian matrix is able to ensure the best PID parameters obtained especial when there is disturbance or the change of the reference value. PID parameters are quickly modified to meet the control requirement and good control performance is guaranteed.
- Control system has fast response speed while using step input. The time constant is 0.02s and settling time is 0.335s while the sampling interval is 0.001s. Moreover, zero overshoot and steady state error show good control accuracy and stability.

BPNN-PID

Recent studies claim that indoor air quality can significantly affect the people's health and productivity. There are many types of indoor air pollutants and it is impossible to control all of them. Hence, in this project, the CO₂ is selected as the control signal since when CO₂ is controlled at the acceptable level, all the others can be considered to be kept at the safe level. A BPNN-PID control was designed to

achieve the goal of maintaining good indoor air quality. Theoretically analysis according to literatures and its algorithm shows that the novel controller has the following advantages for CO₂ control:

- PID controller is suitable for various control object including IAQ,
- neural networks for optimal PID parameters tuning to ensure quick recovery from disturbances,
- back-propagation algorithm for adjustment of weights in neural network to ensure the system quickly response to indoor climate change.

The simulating tests based on the indoor CO₂ concentration varying model have been carried out to indicate the BPNN-PID control performance. The simulating results show that the proposed controller has good control performance as follows:

- Control system has fast control speed response to step input. The time constant is 0.02s and settling time is 0.007s while the sampling interval is 0.001s. Moreover, overshoot percentage is 4.2% and steady state error is zero. This shows fast response speed, good control accuracy and stability.
- Back-propagation algorithm helps to update the weights in the network ensures that the proper weight is updated as the condition change especially when disturbances are introduced to the control system or the reference signal value changes.
- With the proper weights in the network, the best PID parameters can be obtained quickly response to any change of the control process.
- Hence, simulating results prove that the propose controller can be coping with time varying parameter since the control strategy can keep optimizing the PID parameters when there are changes to the control process.

6.1.2 Indoor environment improvement

The temperature, humidity and CO₂ concentration are controlled by fuzzy-PID controller in the experiments. In this section, the improvement of the indoor environment as a result of implementing the fuzzy-PID controller is discussed based on the experimental results.

Temperature

The tests of indoor temperature control are carried out through the period from October 2012 to March 2013. If the indoor temperature is not properly controlled during the experiments period, the indoor temperature would be either similar to the outdoor temperature which is cold or too hot due to overheating. Additionally, the indoor environment would be not only uncomfortable but also unhealthy for occupants. The temperature measurements from six working days, one from each month are drawn in curves as shown in Section 5.3 in this thesis. The results show that the indoor temperature is well improved by using the proposed controller.

- The indoor temperature is similar to the outdoor temperature and is needed to be heated. The heater starts one hour (this time is chosen based on our pre-measurement) before the scheduled working hours based on the fuzzy-PID control. The indoor temperature is brought to the set-point rapidly.
- When the control process enters the steady state, the indoor temperature settles, stays relatively stable and varies without big and sharp change. The monthly mean temperature as presented in Figure 5-27 shows the controller has small steady error that control accuracy can be guaranteed.
- When there are disturbances that cause the indoor environment suddenly change, the fuzzy logic control rule can quickly learn the situation and modify the control parameters for better control performance. The disturbances in the

experiments include 1) open the windows or door (modeled by the door of the environmental chamber) for long period or frequently; 2) more people enters the indoor environment (increase the heat source). Results show there is no unacceptable temperature and overheating happened.

- The standard deviation as shown in Figure 5-28 prove that the indoor temperature is controlled to be varying close to the set-point and spread over small range. This result shows that the control has excellent stability and adaptability. Hence, the indoor temperature can be well controlled in any situations.

Relative humidity

The experiments are carried out in an environmental chamber (used to simulate the office area) during the period from the October 2013 to March 2013. The indoor environment needs to be humidified with proper control. Otherwise, the indoor environment would be too dry or over humidified and it is not a comfortable and healthy environment for occupants inside buildings. The profiles of the indoor relative humidity variation in six working days one in each month are presented in Section 5.4. Moreover, the characteristic features: mean and standard deviation of the collected data are calculated. The results show that the indoor relative humidity is well improved by using the proposed controller.

- At the beginning of each day, the indoor temperature is much lower than the set-point. The humidifier starts thirty minutes (based on our measurement since it generally takes 30 minutes to bring the indoor relative humidity up to the acceptable level) before the scheduled working hours.
- Then the indoor relative humidity level is brought to the set-point and settled within the acceptable range. The monthly mean relative humidity as presented in

Figure 5-35 shows that mean values are all very close the set-point. Hence, the controller has small steady error that control accuracy can be guaranteed.

- The situations that the disturbances (opening the windows or door that causes the indoor condition suddenly changed) introduced to the indoor environment are simulated. Response of the controller to the disturbances is quick and there is no unstable situation occurred.
- The standard deviation as shown in Figure 5-36 prove that the indoor temperature is controlled to be varying close to the set-point and spread over small range. This result shows that the controller has excellent stability and adaptability.
- Hence, the indoor environment is significantly improved by properly controlling the relative humidity in any situations.

CO₂

The tests of indoor CO₂ control are carried out to investigate the indoor air quality improvement by using the proposed controller. The experiments are carried out during the period between October 2012 and March 2013. Hence, the indoor CO₂ level is impossible to bring down to the acceptable level by nature ventilation. The ventilation with proper control strategy is needed to maintain the indoor air quality for occupants' comfort and health. The data of indoor CO₂ change collected in six working days, one in each month are presented in Section 5.5. Moreover, the characteristic features: mean and maximum of the collected data are calculated to help to analyse the indoor environment improvement. The results show that the indoor air quality is well improved by using the proposed controller.

- At the beginning of each day, the indoor CO₂ level is similar to the outdoor's and there is no need to start ventilating when it is occupied. Then when the CO₂ level

is increasing towards 1000ppm, the controller starts to control the fan to supply fresh air into the indoor zone. Results show that the CO₂ is well controlled during this period since the rising trend of CO₂ level is stopped before it is over the set-point.

- When the control process enters the steady state, the indoor CO₂ is varies around the set-point without big and sharp change. Proper indoor air quality is proved and it is good to improve people's working efficiency.
- The monthly mean CO₂ level as presented in Figure 5-43 shows that mean values are all very close the set-point. In addition, the maximum mean CO₂ levels in each month are shown in Figure 5-44 and the big maximum value is within the acceptable level.
- In order to further test the indoor environment improvement, the disturbances are introduced to the control process. When the situation that the indoor occupancy level suddenly increases, the controller is able to quickly modify its control parameters. The results show that the CO₂ level is well under control and there is no poor air quality provided. When the occupancy level suddenly decreases, the controller also quickly reacts to the situation and there is no over ventilation occurred.
- The experimental results show that the indoor air quality is properly controlled during the working hours. It is maintain at the acceptable level and even when there are sudden situations happened the indoor CO₂ level is still controlled within acceptable level. Moreover, there is no poor indoor air quality and over ventilation observed in the experiments.

6.1.3 Discussion of the concept of controller design

The proposed control has been proved to have excellent performance and to be able to improve the indoor environment quality. Hence, the strategy of designing the introduce controllers is discussed in this section.

The drawbacks of the current HVAC control technologies are summarized in Section 2.3. These drawbacks limit the use of controllers for indoor environments control. In order to solve these problems, researchers and engineers are studying on how to improve the controllers' performance. Hence, researches have been carried out to overlap between different categories of controllers for developing control strategies for different purpose. These studies are based on both the advantages and disadvantages so that newly designed controllers can have the merits from different technologies.

Hence, in this thesis, a strategy of designing controller for the purpose of improving indoor environment quality is introduced: combining the conventional controller and intelligent control technique to develop novel control strategy. There are three controllers introduced: a fuzzy-PID controller, a RBFNN-PID controller and a BPNN-PID controller. The proposed controllers are all designed based on conventional PID controller and intelligent controllers. The main structure of the controllers is shown in Figure 6-1. The PID controller is used to control plant because it is practical and can be used for variety of controls. The PID control is most widely used control technology even though lots of researchers claim that it has many disadvantages. The intelligent control is used to tune the PID parameters automatically for the best PID control performance.

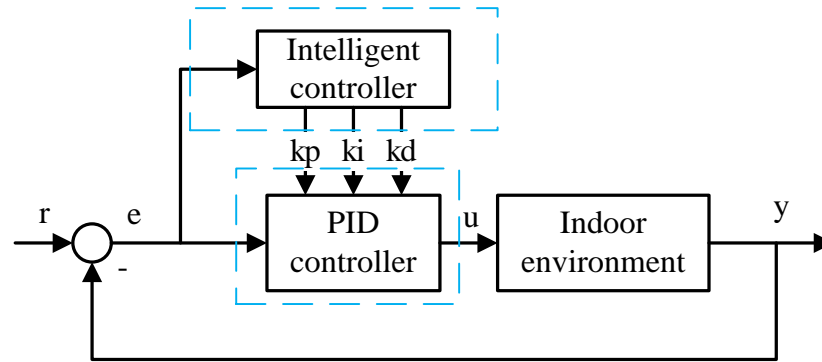

Figure 6-1 Structure of controller combined PID control and intelligent algorithm

The purpose of using such concept of controller design is to use the merits of each control method and to avoid the drawback of them.

- The advantages and disadvantages of the current control methods are summarized in Section 2.2 and 2.3. The PID controller is very practical and widely use for indoor climate control. The performance of PID controller is mainly based on the selection of the three term parameters and the PID parameters tuning is based on the designers' experience. Hence the regulation of PID parameters is a time cost work and incorrect selections may lead to poor control performance. In addition, the PID controller needs to be designed based on the building model and mismatch of control object model may lead to poor control performance. This fact shows that PID controller doses not have very good adaptability and when there are disturbances the required control performance cannot be guaranteed. Hence intelligent controller is designed to regulate the PID parameters automatically to ensure the optimized control output. Thus, the adaptability and stability of PID controller can be improved by applying proper designed FLC and NN to the control strategy. In this way, the control performance of conventional PID controllers can be significantly improved by working associate with intelligent control technologies.

- The advantages of intelligent controllers compared to conventional control methods are better adaptability and the robust steady state in any situations. Intelligent controllers like fuzzy logic control and neural network are suitable for analyzing complicated indoor conditions such as when there are sudden changes to the indoor environment. However, their major disadvantage as discussed in Section 2.3 is difficult to put into real applications. Thus, the PID controller improves the practicality of the fuzzy logic and neural network.

Combining the conventional PID controller and intelligent controllers has improved the control performance of both these two types of controllers. The results shown in Chapter 4 prove the proposed controllers' performance can be guaranteed by this type of control concept.

6.1.4 Contribution to knowledge

(1) Summary of shortcomings of current control method for IEQ control

In this research, the current control technologies for indoor environment quality improvement are reviewed. Moreover, the advantages and shortcomings of these control technologies are summarized in this research as discussed in Section 2.3 and this is a novel review work in the research area of IEQ control technology. Based on the review work, the possible ways to improve current IEQ control technologies are introduced.

(2) Novel control strategy for controller design

In this research, the controllers are developed based on the novel control strategy of combining the conventional and intelligent control technologies. The principle of the control strategy is to merge the advantages of both conventional and intelligent control technologies and avoid their disadvantages. The conventional control selected in this research is PID control. The intelligent controllers chosen are fuzzy logic

control and neural net work. By combining with the intelligent controller, the PID parameters can be automatically tuned for better control performance. By combining with PID controllers, fuzzy logic control and neural networks can be easily implemented to applications.

(3) Fuzzy-PID controller for IEQ improvement

In order to analyse improvement of indoor environment quality by using advanced control method, a fuzzy-PID controller is designed by combing conventional PID control and intelligent fuzzy logic control. There are some studies related to fuzzy-PID control [244] but applied this control strategy to indoor environment quality control is a novel work. The fuzzy-PID control is developed for indoor climate control including temperature, humidity and indoor air quality control in this research. Fuzzy-PID controllers can be used instead of linear PID controller in all classical or modern control system applications. They can convert the error between the measured or controlled variable and the reference variable, in to a command, which is applied to the actuator of a process. In this research, the performance of fuzzy-PID controller is firstly tested by the computational simulation. While using step signal as the input reference the controller shows good control performance since the time constant is 0.033s and settling time is 0.092s with sampling interval of 0.001s. Not only fast response speed, the proposed controller also has good control accuracy and stability since the overshoot and steady state error is zero. Then the IEQ improvement with fuzzy-PID control method is investigated by experiments. In the experiments, the fuzzy-PID controller is used to control indoor temperature, humidity and CO₂ concentration. The fuzzy-PID control performance is analysed by the experimental results. The results of temperature control show that the temperature is controlled to be varying around the set-point and control accuracy is about 4.4%. The humidity control shows similar results that the control accuracy is about 3.2%. For the IAQ control the maximum indoor concentration is kept lower than 1100ppm

which is acceptable and health CO₂ level although it is slightly higher than the set-point of 1000ppm. The experimental results show that the proposed fuzzy-PID controller has good control performance and is able to improve indoor environment quality.

(4) RBFNN-PID control strategy for indoor humidity control

The purpose of this research is to analyse the potential of using advanced control method to improve indoor climate quality. Hence a novel humidity controller based on RBFNN-PID control is developed besides the fuzzy-PID controller. The advantage of RBF neural network is fast processing and learning speed. Hence, the RBFNN-PID controller is designed for humidity control in order to solve its major problem as discussed in Chapter 2. The performance of RBFNN-PID controller is indicted by the computational simulation. While using step signal as the input reference the controller shows good control performance since the time constant is 0.002s and settling time is 0.335s with sampling interval of 0.001s. Not only fast response speed, the proposed controller also has good control accuracy and stability since the overshoot and steady state error is zero. The experimental investigation of RBFNN-PID controller is not included in this research and will be carried out in future work.

(5) BPNN-PID control strategy for indoor IAQ control

The CO₂ is chosen as the control signal of IAQ control since when CO₂ is kept at acceptable level most other indoor air pollutants are kept at acceptable levels. The major difficulties of indoor CO₂ concentration control include existence of mismeasurement and disturbances. The disturbance is caused mainly because CO₂ is very sensitive to occupancy level. Hence a novel IAQ controller using BPNN-PID control technology is developed in this research. The PID controller is used for indoor CO₂ concentration control. The neural network is used of PID parameters

tuning and the back-propagation algorithm is used for updating the weights of the neural network. The advantage of this control strategy is disturbances resistance and it is suitable for CO₂ control. The control performance is verified by simulation using Matlab code. While using step signal as the input reference the controller shows good control performance since the time constant is 0.002s and settling time is 0.335s with sampling interval of 0.001s. The overshoot percentage is about 4.2% and the steady state error is zero. The results show the controller has fast response speed, good control accuracy and stability. The experimental investigation of BPNN-PID controller is not included in this research and will be carried out in future work.

6.2 Conclusion

The main works that have been done in this research are concluded in this section.

Firstly, the studies about the current control methods used for HVAC systems have been reviewed. Then the drawbacks of the current HVAC control methods are summarized based on the literature review. Since this research aims to analysis the potential of improving indoor occupants' comfort using novel control strategies, the future perspectives and approaches that might solve the current control problems are discussed.

Then, based on the discussion of the advantages and disadvantages of current control technologies, novel controllers are developed. In this research, three controllers are developed. Fuzzy PID control is designed for indoor climate control including temperature, humidity and indoor air quality control. Its principle is introduced in Section 3.2. The performance of fuzzy-PID controller is investigated by computational simulations in Chapter 4 and experimental tests in Chapter 5. RBFNN-PID is designed for indoor humidity and BPNN-PID control is designed for indoor CO₂. Their principles and detailed designs are introduced in Chapter 3. These two controllers are only tested by computational simulation in this research and the

experiments to indicate their performance will be carried out in future work. Then the theoretical analysis is carried out to discuss the control performance. In this way, the advantages and disadvantages of each proposed controller are understood in advance.

In addition, computational simulations are used to conduct the performance of the control strategies. This work is necessary because the indexes to evaluate the controllers can be observed and discussed. This create a way understand the develop technologies. If there are dissatisfied indexes, the control technologies have to be modified before applied to real applications. The simulating tests are studied on the platform of Matlab. The programming codes have been developed to simulate the control strategies and the indoor environment model for testing the controllers' performance.

Finally, the experiments are carried out in an environmental chamber to indicate fuzzy-PID controller's performance of indoor temperature, indoor humidity and indoor air quality in buildings. The environmental chamber is used to represent the control object, a medium office area. The experiment is carrying out in a wide period from late fall to early spring. Hence, the indoor environment requires the HVAC operation of heating and humidifying. A heater, a humidifier and fans are controlled to manage the indoor climate and the control signals are temperature, humidity and CO₂ concentration. Several conditions that might happen in real buildings have been simulated to help to test the control performance. The results prove that the indoor environment has been improved by the fuzzy-PID controller.

6.3 Future work

The major work of this research is to discuss the potential of improving the indoor environment quality by using novel controllers. The results show that excellent control performance and occupants' comfort improvement have been achieved. But there are future works need to be carried out.

The experimental investigation of RBFNN-PID controller and BPNN-PID controller will be carried out since they are only tested by computer simulations in this research.

The indoor environment including temperature, relative humidity and indoor air quality in a medium office area could be significantly improved by using the proposed controllers based on the experimental results. According to current studies, there are no model independent HVAC controllers that are suitable for all types of buildings. Hence, one of the major future works is to improve the controllers' practicality and to apply the proposed controllers to other types of indoor environment. Experimental investigation should be carried out to study this subject.

In this research, the temperature, relative humidity and CO₂ control are studied separately. However, in real buildings, the three parameters are affected by each other, and the change of one parameter may cause other parameters to change. Hence, future work should be carried out to develop a control strategy that combines the three controllers together.

According to the experimental results of CO₂ control, the actual indoor occupancy level can be determined by observing the variation of indoor CO₂ concentration. The CO₂ variation curves in Figure 5-37 – Figure 5-42 show that the actual occupancy level can be different from the scheduled occupancy level (based on the scheduled work hours). Hence, in order to improve the performance of indoor occupants' comfort control and to avoid overworking of the equipments, it is necessary to include the algorithm of occupant determination in the control strategy. Using CO₂ concentration change can be an efficient way to do this work and studies should be carried out in future work.

Reference

- [1] Yu BF, Hu ZB, Liu M. Review of research on air conditioning systems and indoor air quality control for human health. *Int J Refrig-Rev Int Froid*. 2009;32:3-20.
- [2] Graudenz GS, Oliveira CH, Tribess A. Association of air-conditioning with respiratory symptoms in office workers in tropical climate. *Indoor Air*. 2005;15:62-6.
- [3] deDear RJ, BragerGS. Thermal comfort in naturally ventilated buildings: revisions toASHRAEStandard55. *EnergyandBuildings*2002;34(6):549–61.
- [4] Taleghani, M., Tenpierik, M., Kurvers, S., a review into thermal comfort in buildings, *Renewable and Sustainable Energy Reviews*, 26 (2013) 201-215
- [5] Seppanen O, Fisk WJ. Association of ventilation system type with SBS symptoms in office workers. *Indoor Air*. 2002;12:92-112.
- [6] Wolkoff, P. Indoor air pollutants in office environments: Assessment of comfort, health, and performance, *International Journal of Hygiene and Environmental Health* 216(2013) 371-394
- [7] Yang, S., Wu, S., Yan, Y.Y., 2013. Control strategies for indoor environment quality and energy efficiency—a review, *International Journal of Low-Carbon Technologies*, doi:10.1093/ijlct/ctt051.
- [8] S.W. Wang, *Intelligent Buildings and Building Automation*, Spon Press (Taylor & Francis), London and New York, 2010.
- [9] B.W. Olesen, Revision of EN 15251: indoor environmental criteria, *REHVA Journal* 49 (4) (2012) 6–12.
- [10] ISO, *International Standard 7730*. 1984, ISO Geneva; revised 1990.
- [11] Nicol JF. *Thermal comfort – a handbook for field studies toward an adaptive model*. London: University of EastLondon; 1993.
- [12] Sayigh A, Marafia AH. Chapter1—Thermal comfort and the development of bioclimatic concept in building design. *Renewable and Sustainable Energy Reviews*1998;2(1–2):3–24.
- [13] Omer AM. Renewable building energy systems and passive human comfort solutions. *Renewable and Sustainable Energy Reviews*2008; 12(6):1562–87.
- [14] Raw, GJ and Oseland, NA., Why another thermal comfort conference? In: *Thermal comfort: past, present and future*. The Building Research Establishment: Garston; 1994.p.1–10.
- [15] Khodakarami J, Nasrollahi N. Thermal comfort in hospitals—a literature review. *Renewable and Sustainable Energy Reviews* 2012;16(6):4071–7.
- [16] Ormandy D, Ezratty V. Health and thermal comfort: from WHO guidance to housing strategies. *Energy Policy* 2012;49(0):116–21.
- [17] Chen A, Chang VWC. Human health and thermal comfort of office workers in Singapore. *Building and Environment* 2012;58(0):172–8.

- [18] Leyten JL, Kurvers SR, Raue AK. Temperature, thermal sensation and workers' performance in air-conditioned and free-running environments. *Architectural Science Review* 2013;56(1):14–21. <http://dx.doi.org/10.1080/00038628.2012.745391>.
- [19] Epstein Y, Moran DS. Thermal comfort and the heat stress indices 2006; 44: 388–98 *Industrial Health* 2006; 44: 388–98.
- [20] Liu, Y., Yan, H., Lam, J.C., Thermal comfort and building energy consumption implications –A review, *Applied Energy*, 115 (2014) 164-173
- [21] Humphreys MA. Thermal comfort temperatures world-wide – the current position. *Renew Energy* 1996; 7: 139–44.
- [22] Humphreys, M., Thermal comfort requirements, climate and energy., In: Sayigh AAM, editor. *The Second World Renewable Energy Congress*,. 1992, Pergamon.
- [23] Humphreys MA, Nicol JF. Understanding the adaptive approach to thermal comfort, field studies of thermal comfort and adaptation. *ASHRAE Technical Data Bulletin* 1998;14(1):1–14.
- [24] Humphreys MA, Nicol FJ. The validity of ISO-PMV for predicting comfort votes in every-day thermal environments. *Energy and Buildings* 2002;34 (6):667–84.
- [25] de Dear RJ, Brager GS. Thermal comfort in naturally ventilated buildings: revisions to ASHRAE Standard 55. *Energy Build* 2002;34:549–61.
- [26] Van der Linder AC, Boerstra AC, Raue AK, Kurvers SR, de Dear RJ. Adaptive temperature limits: a new guideline in the Netherlands a new approach for the assessment of building performance with respect to thermal indoor climate. *Energy Build* 2006;38:8–17.
- [27] Nicol F, Humphreys M. Derivation of the adaptive equations for thermal comfort in free-running buildings in European standard EN15251. *Build Environ* 2010;45:11-7.
- [28] Roaf S, Nicol F, Humphreys M, Tuohy P, Boerstra A. Twentieth century standards for thermal comfort: promoting high energy buildings. *Architect Sci Rev* 2010;53:65–77.
- [29] Yao R, Liu J, Li B. Occupants' adaptive response and perception of thermal environment in naturally conditioned university classrooms. *Appl Energy* 2010;87:1015–22.
- [30] Yun GY, Kong HJ, Kim JT. The effect of seasons and prevailing environments on adaptive comfort temperatures in open plan office. *Indoor Built Environ* 2012;21:41–7.
- [31] Liang HH, Lin TP, Hwang RL. Linking occupants' thermal perception and building thermal performance in naturally ventilated school buildings. *Applied Energy* 2012;94:355–63.

- [32] Indraganti M. Thermal comfort in naturally ventilated apartments in summer: findings from a field study in Hyderabad, India. *Applied Energy* 2010;87:866–83.
- [33] Nicol JF, Humphreys MA. New standards for comfort and energy use in buildings. *Build Res Inform* 2009;37:68–73.
- [34] International Organization for Standardization, ISO Standard 7730, Moderate thermal environments – determination of the PMV and PPD indices and specifications of the conditions for thermal comfort, Geneva: ISO, 1994.
- [35] R. Zmeureanu, A. Doramajian, Thermally acceptable temperature drifts can reduce the energy consumption for cooling in office buildings, *Building and Environment* 1992;27: 469-481.
- [36] Baughman AV, Arens EA, Indoor humidity and human health-Part I: Literature review of health effects of humidity-influenced indoor pollutants, *ASHRAE Transaction* 1996; 102: 193-211.
- [37] Bravery AF, Trepte L, et al., Energy conservation in buildings and community systems programme, Annex IX minimum ventilation rates, Final report of working phases I and II, International Energy Agency (IEA), Stephanus, Uhldingen-Muhlhofen, 1987, p.189
- [38] U.S. Environmental Protection Agency, Indoor Air Pollution: An Introduction for Health Professionals, Co-sponsored by: The American Lung Association (ALA), The Environmental Protection Agency (EPA), The Consumer Product Safety Commission (CPSC), and The American Medical Association (AMA), U.S. Government Printing Office Publication No. 1934-523-217/81322, EPA 402-R-94-007, 1994.
- [39] Bluysen, P.M., De Olivera Fernandes, E., Groes, L., Clausen, G., Fanger, P.O., Valbjørn, O., Bernhard, C.A., Roulet, C.A., 1996. European indoor air quality audit project in 56 office buildings. *Indoor Air* 6, 221–238.
- [40] Brightman, H.S., Milton, D.K., Wypij, D., Burge, H.A., Spengler, J.D., 2008. Evaluating building-related symptoms using the US EPA BASE study results. *Indoor Air* 18, 335–345.
- [41] Marmot, A.F., Eley, J., Stafford, S.A., Warrick, E., Marmot, M.G., 2006. Building health: an epidemiological study of sick building syndrome in the Whitehall II study. *Occup. Environ. Med.* 63, 283–289.
- [42] Danuser, B., 2001. Candidate physiological measure of annoyance from airborne chemicals. *Chem. Senses* 26, 333–337.
- [43] Holland, R.W., Hendriks, M., Aarts, H., 2005. Smells like clean spirit – nonconscious effects of scent on cognition and behaviour. *Psychol. Sci.* 16, 689–693.
- [44] Danuser, B., Moser, D., Vitale-Sethre, T., Hirsig, R., Krueger, H., 2003. Performance in a complex task and breathing under odor exposure. *Hum. Factors* 45, 549–562.

- [45] Kleemann, A.M., Kipoetz, R., Albrecht, J., Schopf, V., Pollatos, O., Schreder, T., May, J., Linn, J., Bruckmann, H., Wiesmann, M., 2009. Investigation of breathing parameters during odor perception and olfactory imagery. *Chem. Senses* 34, 1–9.
- [46] Schiffman, S.S., Walker, J.M., Dalton, P., Lorig, T.S., Raymer, J.H., Shusterman, D., Williams, C.M., 2000. Potential health effects of odour from animal operation wastewater treatment and recycling of byproducts. *J. Agromed.* 7, 7–81.
- [47] Schiffman, S.S., Williams, C.M., 2005. Science of odor as a potential health issue. *J. Environ. Qual.* 34, 129–138.
- [48] Shusterman, D., Lipscomb, J., Neutra, R., Satin, K., 1991. Symptom prevalence and odor-worry interaction near hazardous waste sites. *Environ. Health Perspect.* 94, 25–30.
- [49] Fiedler, N., Kelly-McNeil, K., Ohman-Strickland, P., Zhang, J., Ottenweller, J., Kipen, H., 2008. Negative affect and chemical intolerance as risk factor for building-related symptoms: a controlled exposure study. *Psychosom. Med.* 70, 254–262.
- [50] Marchand, S., Arsenault, P., 2002. Odors modulate pain perception. A gender-specific effect. *Physiol. Behav.* 76, 251–256.
- [51] Campenni, C.E., Crawley, E.J., Meier, M.E., 2004. Role of suggestion in odor-induced mood change. *Psychol. Rep.* 94, 1127–1136.
- [52] Moss, M., Cook, J., Wesnes, K., Duckett, P., 2003. Aromas of rosemary and lavender essential oils differentially affect cognition and mood in healthy adults. *Int. J. Neurosci.* 113, 15–38.
- [53] Lehrner, J., Eckersberger, C., Walla, P., Potsch, G., Deecke, L., 2000. Ambient odor of orange in a dental office reduces anxiety and improves mood in female patients. *Physiol. Behav.* 71, 83–86.
- [54] Villemure, C., Slotnick, B.M., Bushnell, M.C., 2003. Effects of odors on pain perception: deciphering the roles of emotion and attention. *Pain* 106, 101–108.
- [55] Bulsing, P.J., Smeets, M.A.M., van den Hout, M.A., 2009. The implicit association between odors and illness. *Chem. Senses* 34, 111–119.
- [56] De Peuter, S., Van Diest, I., Lemaigre, V., Li, W., Verleden, G., Demedts, M., Van den Bergh, O., 2005. Can subjective asthma symptoms be learned? *Psychosom. Med.* 67, 454–461.
- [57] Knasko, S.C., 1996. Human responses to ambient olfactory stimuli. In: Gammage, R.B., Berven, B.A. (Eds.), *Indoor Air and Human Health*. Lewis Publishers, Boca Raton, pp. 107–123.
- [58] Segala, C., Poizeau, D., Maze, J.M., 2003. Odors and health: a descriptive epidemiological study around a wastewater treatment plant. *Rev. Epidemiol. Sante Publique* 51, 201–214.
- [59] Schiffman, S.S., Studwell, C.E., Landermann, L.R., Berman, K., Sundy, J.S., 2005. Symptomatic effects of exposure to diluted air sampled from a swine

- confinement atmosphere on healthy human subjects. *Environ. Health Perspect.* 113, 567–576.
- [60] Baron, R.A., 1990. Environmentally induced positive affect. Its impact on self-efficacy task performance negotiation and conflict. *J. Appl. Soc. Psychol.* 20, 368–384.
- [61] Michael, G.A., Jacquot, L., Millot, J.L., Brand, G., 2005. Ambient odors influence the amplitude and time course of visual distraction. *Behav. Neurosci.* 119, 708–715.
- [62] Millot, J.L., Brand, G., Morand, N., 2002. Effects of ambient odors on reaction time in humans. *Neurosci. Lett.* 322, 79–82.
- [63] Sakamoto, R., Minoura, K., Usui, A., Ishizuka, Y., Knaba, S., 2005. Effectiveness of aroma on work efficiency: lavender aroma during recess prevents deterioration of work performance. *Chem. Senses* 30, 683–691.
- [64] Degel, J., Koster, E.P., 1999. Odors: implicit memory and performance effects. *Chem. Senses* 24, 317–325.
- [65] Hey, K., Juran, S., Schaper, M., Kleinbeck, S., Kiesswetter, E., Blaszkewicz, M., Meinolf, G., Bruning, T., van Thriel, C., 2009. Neurobehavioral effects during exposure to propionic acid – an indicator of chemosensory distraction? *Neurotoxicology* 30, 1223–1232.
- [66] Ioan S., Calin S. Aspects of indoor environmental quality assessment in buildings, *Energy and Buildings* 60(2013) 410-419
- [67] L.T. Wong, K.W. Mui, P.S. Hui, A statistical model for characterizing common air pollutants in air-conditioned offices, *Atmospheric Environment*, 40 (2006) 4246–4257.
- [68] P.S. Hui, L.T. Wong, K.W. Mui, Feasibility study of an express assessment protocol for the indoor air quality of air-conditioned offices, *Indoor and Built Environment* 15 (2006) 373–378.
- [69] K.W. Mui, L.T. Wong, P.S. Hui, Epistemic evaluation of policy influence on workplace indoor air quality of Hong Kong in 1996–2005, *Building Services Engineering Research and Technology* 29 (2008) 157–164.
- [70] Song, Y., Wu, S., Yan, Y., Development of Self-Tuning Intelligent PID Controller Based on 115 for Indoor Air Quality Control, *International Journal of Emerging Technology and Advanced Engineering*, 3:11:283-290, 2013.
- [71] Mui, K.W., Wong, L.T., Hui, P.S. and Law, K.Y. 2008. Epistemic evaluation of policy influence on workplace indoor air quality of Hong Kong in 1996–2005, *Building Services Engineering Research and Technology*, 29(2), 157–164.
- [72] Persily, A.K. 1997. Evaluating building IAQ and ventilation with indoor carbon dioxide, *ASHRAE Transactions*, 103(2), 193–203.
- [73] ASTM, 2003. Standard guide for using indoor carbon dioxide concentrations to evaluate indoor air quality and ventilation, D6245-98, (reapproved 2002).
- [74] Committee of European Normalization, *Ventilation for buildings: design criteria for the indoor environment*. Brussels, Luxembourg: Commission of the

- European Communities, Directorate General for Science, Research and Development Joint Research Centre-Environment Institute, CR1752, 1998.
- [75] ANSI/ASHRAE, ANSI/ASHRAE Standard 62-2007, Design for acceptable indoor air quality, American Society of Heating, Refrigerating and Air-Conditioning Engineers, Inc., Atlanta: ASHRAE, 2007
- [76] K.W. Mui, L.T. Wong, Evaluation of neutral criterion of indoor air quality for air conditioned offices in subtropical climates, *Building Services Engineering Research and Technology* 28 (2007) 23–33.
- [77] S.A. Mumma, Y. Ke, Field testing of advanced ventilation controls for variable air volume systems, *Environment International* 24 (1998) 439-450
- [78] IPCC. Climate Change 2007, In: Solomon S, et al., editors, The physical science basis. Contribution of the working group I to the fourth assessment report of the intergovernmental panel on climate change, Cambridge; 2007.
- [79] Lean HH, Smyth R. CO₂ emissions, electricity consumption and output in ASEAN. *Appl Energy* 2010;87:1858–64.
- [80] Chang CC. A multivariate causality test of carbon dioxide emissions, energy use and economic growth in China. *Appl Energy* 2010;87:3533–7.
- [81] Govindaraju VGRC, Tang CF. The dynamic links between CO₂ emissions, economic growth and coal consumption in China and India. *Appl Energy* 2013;104:310–8.
- [82] Sharma SS. Determinants of carbon dioxide emissions: empirical evidence from 69 countries. *Appl Energy* 2011;88:376–82.
- [83] International Energy Agency (IEA). World energy outlook 2010. Paris: OECD/IEA; 2010.
- [84] Liu W, Lund H, Mathiesen BV, Zhang X. Potential of renewable energy systems in China. *Appl Energy* 2011;88:518–25.
- [85] Wang K, Wei YM, Zhang X. Energy and emissions efficiency patterns of Chinese regions: a multi-directional efficiency analysis. *Appl Energy* 2013;104:105–16.
- [86] Q, Zhang X. Technologies and policies for the transition to a sustainable energy system in China. *Energy* 2010;35:3995–4002.
- [87] Perez-Lombard L, Ortiz J, Pout C. A review on buildings energy consumption information. *Energy Build* 2008;40:394–8.
- [88] Fiaschi D, Bandinelli R, Conti S. A case study for energy issues of public buildings and utilities in a small municipality: investigation of possible improvements and integration with renewables. *Appl Energy* 2012;97:101–14.
- [89] Yao R, Li B, Steemers K. Energy policy and standard for built environment in China. *Renew Energy* 2005;13:1973–88.
- [90] Wang J, Zhai ZJ, Jing Y, Zhang C. Influence analysis of building types and climate zones on energetic, economic and environmental performance of BCHP systems. *Appl Energy* 2011;88:3097–112.

- [91] Costa A, Keane MM, Torrens JJ, Corry E. Building operation and energy performance: monitoring, analysis and optimization toolkit. *Appl Energy* 2013;101:310–6.
- [92] Bojic M, Yik F, Wan K, Burnett J. Influence of envelope and partition characteristics on the space cooling of high-rise residential buildings in Hong Kong. *Build Environ* 2002;37:347–55.
- [93] Yang L, Lam JC, Tsang CL. Energy performance of building envelopes in different climate zones in China. *Appl Energy* 2008;85:800–17.
- [94] Yu J, Yang C, Tian L, Liao D. A study on optimum insulation thickness of external walls in hot summer and cold winter zone of China. *Appl Energy* 2009;86:2520–9.
- [95] Daouas N. A study on optimum insulation thickness in walls and energy savings in Tunisian buildings based on analytical calculation of cooling and heating transmission loads. *Appl Energy* 2011;88:156–64.
- [96] Dongmei P, Mingyin C, Shiming D, Zhongping L. The effects of external wall insulation thickness on annual cooling and heating energy uses under different climates. *Appl Energy* 2012;97:313–8.
- [97] Joudi A, Svedung H, Cehlin M, Ronnelid M. Reflective coatings for interior and exterior of buildings and improving thermal performance. *Appl Energy* 2013;103:562–70.
- [98] Ascione F, Bianco N, de' Rossi F, Turni G, Vanoli GP. Green roofs in European climates. Are effective solutions for the energy savings in air-conditioning. *Appl Energy* 2013; 104:845–59.
- [99] Lam JC, Hui SCM. Sensitivity analysis of energy performance of office buildings. *Build Environ* 1996;31:27–39.
- [100] Perez YV, Capeluto IG. Climatic considerations in school building design in the hot-humid climate for reducing energy consumption. *Appl Energy* 2009;86:340–8.
- [101] Ochoa CE, Aries MBC, van Loenen EJ, Hensen JLM. Considerations on design optimization criteria for windows providing low energy consumption and high visual comfort. *Appl Energy* 2012;95:238–45.
- [102] Manfren M, Aste N, Moshksar R. Calibration and uncertainty analysis for computer models – a meta-model based approach for integrated building energy simulation. *Appl Energy* 2013;103:627–41.
- [103] Asif M, Muneer T, Kelley R. Life cycle assessment: a case study of a dwelling home in Scotland. *Build Environ* 2007;42:1391–4.
- [104] Weir G, Muneer T. Energy and environmental impact analysis of double glazed windows. *Energy Convers Manage* 1998;39:243–56.
- [105] Nikolaidis Y, Pilavachi PA, Chletsis A. Economic evaluation of energy saving measures in a common type of Greek building. *Appl Energy* 2009;86:2550–9.

- [106] Rahman MM, Rasul MG, Khan MMK. Energy conservation measures in an institutional building in sub-tropical climate in Australia. *Appl Energy* 2010;87:2994–3004.
- [107] Chantrelle FP, Lahmidi H, Keilholz W, El Mankibi M, Michel P. Development of a multi-criteria tool for optimizing the renovation of buildings. *Appl Energy* 2011;88:1386–94.
- [108] Popescu D, Nienert S, Schutzenhofer C, Boazu R. Impact of energy efficiency on the economic value of buildings. *Appl Energy* 2012;89:454–63.
- [109] Huang Y, Niu JL, Chung TM. Study on the performance of energy-efficient retrofitting measures on commercial building external walls in cooling dominated cities. *Appl Energy* 2013;103:97–108.
- [110] Siroky J, Oldewurtel F, Cigler J, Privara S. Experimental analysis of model predictive control for an energy efficient building heating system. *Appl Energy* 2011;88:3079–87.
- [111] Marinakis V, Doukas H, Karakosta C, Psarras J. An integrated system for buildings' energy-efficient automation: application in the tertiary sector. *Appl Energy* 2013;101:6–14.
- [112] Oldewurtel F, Sturzenegger D, Morari M. Importance of occupancy information for building climate control. *Appl Energy* 2013;101:521–32.
- [113] Goyal S, Ingle HA, Barooah P. Occupancy-based zone-climate control for energy-efficient buildings: complexity vs. performance. *Appl Energy* 2013;106:209–21.
- [114] Lam JC, Wan KKW, Cheung KL. An analysis of climatic influences on chiller plant electricity consumption. *Appl Energy* 2009;86:933–40.
- [115] Lam TNT, Wan KKW, Wong SL, Lam JC. Impact of climate change on commercial sector air conditioning energy consumption subtropical Hong Kong. *Appl Energy* 2010;87:2321–7.
- [116] Chung W. Review of building energy-use performance benchmarking methodologies. *Appl Energy* 2011;88:1470–9.
- [117] Chua KJ, Chou SK, Yang WM, Yan J. Achieving better energy-efficient air conditioning – a review of technologies and strategies. *Appl Energy* 2013;104:87–104.
- [118] 2010 Residential Energy End-Use Splits, by Fuel Type (Quadrillion Btu), in: Residential Sector Energy Consumption, U.S. Department of Energy. <http://buildingsdatabook.eren.doe.gov/TableView.aspx?table=2.1.5> (accessed 07.09.2012).
- [119] 2010 Commercial Energy End-Use Splits, by Fuel Type (Quadrillion Btu) in: Commercial Sector Energy Consumption, U.S. Department of Energy. <http://buildingsdatabook.eren.doe.gov/TableView.aspx?table=3.1.4> (accessed 07.09.2012).
- [120] Frontczak M, Wargocki P. Literature survey on how different factors influence human comfort in indoor environments. *Build Environ* 2011;46:922–37.

- [121] Radhi H, Eltrapolsi A, Sharples S. Will energy regulations in the Gulf States make buildings more comfortable – a scoping study of residential buildings. *Appl Energy* 2009;86:2531–9.
- [122] Gil-Lopez T, Gimenez-Molina C. Environmental, economic and energy analysis of double glazing with a circulating water chamber in residential buildings. *Appl Energy* 2013;101:572–81.
- [123] Brager GS, de Dear RJ. Thermal adaptation in the built environment: a literature review. *Energy Build* 1998;27:83–96.
- [124] Van Hoof J. Forty years of Fanger’s model of thermal comfort: comfort for all? *Indoor Air* 2008;18:182–201.
- [125] Djongyang N, Tchinda R, Njomo D. Thermal comfort: a review paper. *Renew Sustain Energy Rev* 2010;14:2626–40.
- [126] Taleghani M, Tenpierik M, Kurvers S, van den Dobbelen A. A review into thermal comfort in buildings. *Renew Sustain Energy Rev* 2013;26:201–15.
- [127] Arens E, Humphreys MA, de Dear R, Zhang H. Are ‘class A’ temperature requirements realistic or desirable? *Build Environ* 2010;45:4–10.
- [128] Moon JW, Han SH. Thermostat strategies impact on energy consumption in residential buildings. *Energy Build* 2011;43:338–46.
- [129] Peeters L, de Dear R, Hensen J, D’haeseleer W. Thermal comfort in residential buildings: comfort values and scales for building energy simulation. *Appl Energy* 2009;86:772–80.
- [130] Singh MK, Mahapatra S, Atreya SK. Adaptive thermal model for different climatic zones of North-East India. *Appl Energy* 2011;88:2420–8.
- [131] Chow TT, Lam JC. Thermal comfort and energy conservation in commercial buildings in Hong Kong. *Architect Sci Rev* 1992;35:67–72.
- [132] Zmeureanu R, Doramajian A. Thermally acceptable temperature drifts can reduce the energy consumption for cooling in office buildings. *Build Environ* 1992;27:469–81.
- [133] Sekhar SC. Higher space temperatures and better thermal comfort – a tropical analysis. *Energy Build* 1995;23:63–70.
- [134] Nicol F, Roaf S. Pioneering new indoor temperature standards: the Pakistan project. *Energy Build* 1996;23:169–74.
- [135] Mui KWH, Chan WTD. Adaptive comfort temperature model of air-conditioned building in Hong Kong. *Build Environ* 2003;38:837–52.
- [136] Al-Sanea SA, Zedan MF. Optimized monthly-fixed thermostat-setting scheme for maximum energy-savings and thermal comfort in air-conditioned spaces. *Appl Energy* 2008;85:326–46.
- [137] Roussac AC, Steinfeld J, de Dear R. A preliminary evaluation of two strategies for raising indoor air temperature set-points in office buildings. *Architect Sci Rev* 2011;54:148–56.
- [138] P.O. Fanger, *Thermal Comfort*. Danish Technical Press, Copenhagen, 1970.

- [139] ANSI/ASHRAE Standard 55, Thermal Environmental Conditions for Human Occupancy. American Society of Heating, Refrigerating and Air-Conditioning Engineers, Atlanta, GA, 2004.
- [140] ISO 7730, Ergonomics of the Thermal Environment e Analytical Determination and Interpretation of Thermal Comfort Using Calculation of the PMV and PPD Indices and Local Thermal Comfort Criteria. International Organization for Standardization, Geneva, 2005.
- [141] R.J. de Dear, G.S. Brager, Developing an adaptive model of thermal comfort and preference, *ASHRAE Transactions* 104 (1998) 145-167.
- [142] [142]ISO 7726, Ergonomics of the Thermal Environment - Instruments for Measuring Physical Quantities. International Organization for Standardization, Geneva, 1998.
- [143] EPBD, Directive 2002/91/EC of the European Parliament and of the Council of 16 December 2002 on the Energy Performance of Buildings, *Official Journal of the European Communities* EN (2002) 4.1.2003 L 1/65.
- [144] M. Beccali, A. Nucara, G. Rizzo, Thermal comfort. in: C.J. Cleveland (Ed.), *Encyclopaedia of Energy*, Vol. 6. Elsevier Inc, 2004.
- [145] Cen, EN 15251, Indoor Environmental Input Parameters for Design and Assessment of Energy Performance of Buildings Addressing Indoor Air Quality, Thermal Environment, Lighting and Acoustics. European Committee for Standardization, Brussels, 2007.
- [146] E.H. Mathews, C.P. Botha, Improved thermal building management with the aid of integrated dynamic HVAC simulation, *Building and Environment* 38 (2003) 1423-1429.
- [147] E.H. Mathews, C.P. Botha, D.C. Arndt, A. Malan, HVAC control strategies to enhance comfort and minimise energy saving, *Energy and Buildings* 33 (2001) 853-863.
- [148] K.F. Fong, V.I. Hanby, T.T. Chow, System optimization for HVAC energy management using the robust evolutionary algorithm, *Applied Thermal Engineering* 29 (2009) 2327-2334.
- [149] L. Lu, W. Cai, L. Xie, S. Li, Y.C. Soh, HVAC system optimization-in-building section, *Energy and Buildings* 37 (2005) 11-22.
- [150] R. Karunakaran, S. Iniyar, R. Goic, Energy efficient fuzzy based combined variable refrigerant volume and variable air volume air conditioning system for buildings, *Applied Energy* 87 (2010) 1158-1175.
- [151] G.L. Morini, S. Piva, The simulation of transients in thermal plant. Part I: mathematical model. *Applied Thermal Engineering* 27 (2007) 2138-2144.
- [152] K. Wojdyga, An influence of weather conditions on heat demand in district heating systems. *Energy and Buildings* 40 (11) (2008) 2009-2014.
- [153] S. Ghafghazi, T. Sowlati, S. Sokhansanj, S. Melin, A multicriteria approach to evaluate district heating system. *Applied Energy* 87 (4) (2010) 1134-1140.

- [154] D. Harvey, *A Handbook on Low Energy Buildings and District Energy Systems: Fundamentals, Techniques and Examples*. Earthscan Publications, London, 2006.
- [155] *District Heating and Cooling Country by Country - 2005 Survey*. Euroheat & Power, Brussels, 2005.
- [156] J. Söderman, F. Pettersson, Structural and operational optimization of distributed energy systems. *Applied Thermal Engineering* 26 (2006) 1400-1408.
- [157] V.D. Stevanovic, B. Zivkovic, S. Prica, B. Maslovaric, V. Karamarkovic, V. Trkulja, Prediction of thermal transients in district heating systems. *Energy Conversion and Management* 50 (9) (2009) 2167-2173.
- [158] J.P. McDonald, H.G. Kwatny, Design and analysis of boiler-turbine-generator controls using optimal linear regulator theory. *IEEE Transaction on Automatic Control* AC-18 (3) (1973) 202-209.
- [159] K.S. Bhambare, S.K. Mitra, U.N. Gaitonde, Modeling of a coal-fired natural circulation boiler. *Journal of Energy Resources Technology* 129 (2) (2007) 159-167.
- [160] Soon-Young Choi, Kee-Youn Yoo, Jeong-Bin Lee, et al. (2010) Mathematical modeling and control of thermal plant in the district heating system of Korea, *Applied Thermal Engineering*, 30 p: 2067-2072
- [161] F. Xiao, G. Ge, X. Niu, Control performance of a dedicated outdoor air system adopting liquid desiccant dehumidification, *Applied Energy* 88 (2011) 143-149.
- [162] M. Tu, C.Q. Ren, L.A. Zhang, J.W. Shao, Simulation and analysis of a novel liquid desiccant air-conditioning system, *Appl Therm Eng* 29 (2009) 2417–2425.
- [163] Z. Xiong, Y. Dai, R. Wang, Development of a novel two-stage liquid desiccant dehumidification system assisted by CaCl₂ solution using energy analysis method, *Appl Energy* 87 (2010) 1489–1504.
- [164] Omar M. Al-Rabghi, Mohammed M. Akyurt, A survey of energy efficient strategies for effective air conditioning, *Energy Conversion and Management* 45 (2004) 1643-1654
- [165] C.Y.H. Chao, J.S. Hu, Development of a dual-mode demand control ventilation strategy for indoor air quality control and energy saving, *Building and Environment* 39 (2004) 385-391.
- [166] Edward G. Pita, *Air Conditioning Principles and Systems: An Energy Approach*, 4th ed, Prentice Hall, 2002
- [167] A.I. Dounis, C. Caraiscos, Advanced control systems engineering for energy and comfort management in a building environment-A review, *Renewable and Sustainable Energy Reviews* 13 (2009) 1246-1261.
- [168] G.J. Levermore, *Building energy management systems: an application to heating and control*, London: E & FN SPON, 1992.

- [169] A.I. Dounis, M. Bruant, M.J. Santamouris, G. Guarrancino, P. Michel, Comparison of conventional and fuzzy control of indoor air quality in buildings, *Journal of Intelligent & Fuzzy Systems* 4 (1996) 131–140.
- [170] J. G. Ziegler and N. B. Nichols, “Optimum settings for automatic controllers,” *Trans. ASME*, vol. 64, pp. 759–768, 1942.
- [171] Ang, K.H., Chong, G., (2005), PID control system analysis, design and technology, *IEEE Transaction on control systems technology*, 13(4), pp.559-576
- [172] Y. Li, W. Feng, K. C. Tan, X. K. Zhu, X. Guan, and K. H. Ang, “PIDEasy and automated generation of optimal PID controllers,” in *Proc. 3rd Asia- Pacific Conf. Control and Measurement*, Dunhuang, P.R. China, 1998, pp. 29–33.
- [173] “Digital control: past, present and future of PID control,” in *Proc. IFAC Workshop*, J. Quevedo and T. Escobet, Eds., Terrassa, Spain, Apr. 5–7, 2000.
- [174] K. J. Åström and T. Hägglund, *PID Controllers: Theory, Design, and Tuning*. Research Triangle Park, NC: Instrument Soc. Amer., 1995.
- [175] W. Feng and Y. Li, “Performance indexes in evolutionary CACSD automation with application to batch PID generation,” in *Proc. 10th IEEE Int. Symp. Computer Aided Control System*, Hawaii, Aug. 1999, pp. 486–491.
- [176] “PID Control,” in *The Control Handbook*, W. S. Levine, Ed. Piscataway, NJ: IEEE Press, 1996, pp. 198–209.
- [177] L. Wang, T. J. D. Barnes, and W. R. Cluett, “New frequency-domain design method for PID controllers,” *Proc. Inst. Elect. Eng. D—Control Theory Appl.*, vol. 142, no. 4, pp. 265–271, 1995.
- [178] M. Bojic, M. Despotovic, Influence of duration of thermal comfort provision on heating behavior of buildings, *Energy Conversion and Management* 48 (2007) 2416e2423.
- [179] S. Huang, R.M. Nelson, Rule development and adjustment strategies of a fuzzy logic controller for a HVAC system, *AHSRAE Transactions* 100 (1994) 841e856.
- [180] Yabanova, I., Kecebas, A., Development of ANN model for geothermal district heating system and a novel PID-based control strategy, *Applied Thermal Engineering* 51 (2013) 908e916
- [181] L. Lianzhong, M. Zaheeruddin, Hybrid fuzzy logic control strategies for hot water district heating systems, *Building Services Engineering Research and Technology* 28 (2007) 35e53.
- [182] Ang, K.H. and Chong, G., 2005 PID control system analysis, design and technology, *IEEE Transaction on control system technology*, 13(14):559-567
- [183] C.B. Winn, *Controls in solar energy systems*, *Advances in Solar Energy* (American Solar Energy Society) 1 (1982) 209–220.
- [184] C. Bernard, B. Guerrier, M.M. Rasset-Louerant, Optimal building energy management. Part II: Control, *ASME Journal of Solar Energy Engineering* 114 (1982) 13–22.

- [185] P. Dorato, Optimal temperature-control of solar energy systems, *Solar Energy* 30 (1993) 147–53.
- [186] J.W. Arthur Mac, E.W. Grald, Optimal comfort control for variable-speed heat pumps, *ASHRAE Transactions* 94 (1998) 1283–1291.
- [187] S. Wang, X. Jin, Model-based optimal control of VAV air-conditioning system using genetic algorithms, *Building and Environment* 35 (2000) 471–487.
- [188] M. Zaheer-uddin, G.R. Zheng, Optimal control of time scheduled heating, ventilating and air conditioning processes in buildings, *Energy Conversion and Management* 41 (2000) 49–60.
- [189] J. House, T. Smith, A system approach to optimal control for HVAC and building systems, *ASHRAE Transactions* 101 (1995) 647–660.
- [190] M. Kummert, P. Andre, J. Nicolas, Optimal heating control in a passive solar commercial building, *Solar Energy* 69 (2001) 03–116.
- [191] D. Burghes, A Graham, Introduction to control theory including optimal control. Ellis Horwood Ltd., 1980.
- [192] T. Inoue, T. Kawase, T. Ibamoto, S. Takakusa, Y. Matsuo, The development of an optimal control system for window shading devices based on investigations in office buildings, *ASHRAE Transactions* 104 (1998) 1034–1049.
- [193] H.N. Lam, Stochastic modeling and genetic algorithm based optimal control of air conditioning systems, *Building Simulation* (1993) 435–441.
- [194] P.J. Lute, V.A.H. Paassen, Predictive control of indoor temperatures in office buildings energy consumption and comfort. In: *Clima 2000*, 1989.
- [195] A.H. Paassen, S.H. Liem, P.J. Lute, Digital control systems for passive solar buildings. In: *CEC-Project Pastor*, 1990.
- [196] Milanic S, R. Karba, Neural network models for predictive control of a thermal plant. In: *Proceedings of the international conference on EANN'90* (1996)151–154.
- [197] T. Kusuda, Control of ventilation to conserve energy while maintaining acceptable indoor air quality, *ASHRAE Trans.* 82 (1) (1976) 1169–1181.
- [198] D. Elovitz, Minimum outside air control methods for VAV systems, *ASHRAE Trans.* 101 (2) (1995) 613–618.
- [199] S.W. Wang, X.Q. Jin, Model-based optimal control of VAV air-conditioning system using genetic algorithm, *Build. Environ.* 35 (6) (2000) 471–487.
- [200] S.W. Wang, Enhancing the applications of building automation systems for better building energy and environmental performance, *HVAC&R Res.* 12 (2) (2006) 197–199.
- [201] F.W. Yu, K.T. Chan, Advanced control of heat rejection airflow for improving the coefficient of performance of air-cooled chillers, *Appl. Therm. Eng.* 26 (1) (2006) 97–110.
- [202] X. Jin, Z. Du, X. Xiao, Energy evaluation of optimal control strategies for central VAV chiller systems, *Appl. Therm. Eng.* 27 (5– 6) (2007) 934–941.

- [203] R. Kohonen, S.W. Wang, H. Peitsman, et al., Development of emulation method. IEA Annex 17, Final Report, Helsinki, Finland, 1993.
- [204] M. Mbaye, Z. Aidoun, V. Valkov, et al., Analysis of chemical heat pumps (CHPs): basic concepts and numerical model description, *Appl. Therm. Eng.* 18 (3–4) (1998) 131–146.
- [205] T.Y. Chen, Application of adaptive predictive control to a floor heating system with a large thermal lag, *Energy Build.* 34 (2002) 43–51.
- [206] A. Abbassi, L. Bahar, Application of neural network for the modeling and control of evaporative condenser cooling load, *Appl. Thermal Eng.* 25 (17–18) (2005) 3176–3186.
- [207] S.W. Wang. Dynamic simulation of building VAV air-conditioning system and evaluation of EMCS on-line strategies. *Building and Environment* 1998;36(6)
- [208] K.J. Astrom, B. Wittenmark, *Adaptive Control*, Addison-Wesley Publishing Company, New York, 1989.
- [209] K. M. Lynch, I. B. Schwartz, P. Yang, and R. A. Freeman, “Decentralized environmental modeling by mobile sensor networks,” *IEEE Trans. Robot.*, vol. 24, no. 3, pp. 710–724, Jun. 2008.
- [210] H. Choi and J. How, “Continuous trajectory planning of mobile sensors for informative forecasting,” *Automatica*, vol. 46, no. 8, pp. 1266–1275, 2010.
- [211] J. Choi, J. Lee, and S. Oh, “Swarm intelligence for achieving the global maximum using spatio-temporal Gaussian processes,” in *Proc. Amer. Control Conf.*, Jun. 2008, pp. 135–140.
- [212] J. Choi, S. Oh, and R. Horowitz, “Distributed learning and cooperative control for multiagent systems,” *Automatica*, vol. 45, no. 12, pp. 2802–2814, 2009.
- [213] Y. Xu, J. Choi, and S. Oh, “Mobile sensor network navigation using gaussian processes with truncated observations,” *IEEE Trans. Robot.*, vol. 27, no. 6, pp. 1118–1131, Dec. 2011.
- [214] N. Leonard, D. Paley, F. Lekien, R. Sepulchre, D. Fratantoni, and R. Davis, “Collective motion, sensor networks, and ocean sampling,” *Proc. IEEE*, vol. 95, no. 1, pp. 48–74, Jan. 2007.
- [215] K. Low, G. Podnar, S. Stancliff, J. Dolan, and A. Elfes, “Robot boats as a mobile aquatic sensor network,” in *Proc. ESSA Workshop*, 2009, pp. 1–8.
- [216] J. Williams, J. Fisher, and A. Willsky, “Approximate dynamic programming for communication-constrained sensor network management,” *IEEE Trans. Signal Process.*, vol. 55, no. 8, pp. 4300–4311, Aug. 2007.
- [217] N. A. C. Cressie and C. K. Wikle, “Space-time Kalman filter,” in *Encyclopedia of Environmetrics*, A. H. El-Shaarawi and W. W. Piegorsch, Eds. New York: Wiley, 2002, pp. 2045-2049.
- [218] Jadaliha, M., Choi, J., (2013), *Environmental Monitoring Using Autonomous Aquatic Robots: Sampling Algorithms and Experiments*, *IEEE TRANSACTIONS ON CONTROL SYSTEMS TECHNOLOGY*, 21 (3) pp.899-905

- [219] C.G. Nesler, Adaptive control of thermal processes in buildings, *IEEE Control Systems Magazine* 6 (1986) 9–13.
- [220] Z.J. Ma, S.W. Wang, Energy efficient control of variable speed pumps in complex building central air-conditioning systems, *Energy and Buildings* 41 (2) (2009) 197-205.
- [221] S.W. Wang, Z.J. Ma, Control strategies for variable speed pumps in super high-rise building, *ASHRAE Journal* 52 (7) (2010) 36-43.
- [222] L. Lopez, Sanchez, F. Doctor, H. Hagra, V. Callaghan, An evolutionary algorithm for the off-line data driven generation of fuzzy controllers for intelligent buildings. In: *Systems, man and cybernetics, 2004 IEEE international conference* 1 (2004) 42–47.
- [223] Buhler, H. *Reglage par logique floue*, Presses Polytechnique et Universitaires Romandes, Lausanne, 1994.
- [224] S. Huang, R.M. Nelson, Rule development and adjustment strategies of fuzzy logic controller for an HVAC system. Part 1: Analysis and part two-experiment, *ASHRAE Transactions* 1 (1994) 841–856.
- [225] A.B. Shepherd, W.J. Batty, Fuzzy control strategies to provide cost and energy efficient high quality indoor environments in buildings with high occupant densities, *Building Service Engineering Research and Technology* 24 (2003) 35–45.
- [226] T. Tobi, T. Hanafusa, A practical application of fuzzy control for an air-conditioning system, *International Journal of Approximate Reasoning* 5 (1991) 331–348.
- [227] J. Liang, R. Du, Thermal comfort control based on neural network for HVAC application, In: *Control applications 2005, CCA 2005, proceedings of 2005, IEEE conference*, (2005) 819–824.
- [228] K.V. Ling, A.L. Dexter, G. Geng, P. Haves, Self-tuning control with fuzzy rulebased supervision for HVAC applications, In: *IFAC intelligent tuning and adaptive control* (1991) 205–209.
- [229] Huang, S., & Nelson, R. M. (1994a). Rule development and adjustment strategies of a fuzzy logic controller for an HVAC system: Part one-analysis. *ASHRAE Transaction*, 100(1), 841–850.
- [230] Huang, S., & Nelson, R. M. (1994b). Rule development and adjustment strategies of a fuzzy logic controller for an HVAC system: Part two-experiment. *ASHRAE Transaction*, 100(1), 851–856.
- [231] Hung, L. C., Lin, H. P., & Chung, H. Y. (2007). Design of self-tuning fuzzy sliding mode control for TORA system. *Expert Systems with Applications*, 32, 201–212.
- [232] Tsang, K. M. (2001). Auto-tuning of fuzzy logic controllers for self-regulating processes. *Fuzzy Sets and Systems*, 120, 169–179.

- [233] Mamdani, E.H. (1974). Application of fuzzylogic algorithms for control of simple dynamic plant. *Proceedings of the Institute of Electrical Engineering*, 121, 1585–1588.
- [234] Soyguder, S., Karakose, M., Alli, H. (2009) Design and simulation of self-tuning PID-type fuzzy adaptive control for an expert HVAC system. *Expert Systems with Applications*, 36, 4566-4573
- [235] Macvicar-Whelan, P. J. (1976). Fuzzysets for man–machine interaction. *International Journal of Man–Machine Studies*, 8, 687–697.
- [236] Tang, K. L., & Mulholland, R. J. (1987). Comparing fuzzylogic with classical controller designs. *IEEE Transactions on Systems Man and Cybernetics*, 17(6), 1085 -1087.
- [237] C. Altrock, H.O. Arend, B. Krause, C. Steffens, E. Behrens-Rommler, Adaptive fuzzy control applied to home heating system, *Fuzzy Sets and Systems* 61 (1994) 29–35.
- [238] A.I. Dounis, D.E. Manolakis, Design of a fuzzy system for living space thermal comfort regulation, *Applied Energy* 69 (2001) 119–144.
- [239] A.I. Dounis, M. Santamouris, C.C. Lefas, A. Argiriou, Design of a fuzzy set environment comfort system, *Energy and Buildings* 22 (1994) 81–87.
- [240] D. Kolokotsa, Design and implementation of an integrated intelligent building indoor environment management system using fuzzy logic, advanced decision support techniques, local operating network capabilities and smart card technology, PhD. Technical University of Crete, 2001.
- [241] D. Kolokotsa, K. Niachou, V. Geros, K. Kalaitzakis, G.S. Stavrakakis, M. Santamouris, Implementation of an integrated indoor environment and energy management system, *Energy and Buildings* 37 (2005) 93–99.
- [242] B. Hu, G. Mann, R.G. Gosine, A systematic study of fuzzy PID controllers-Function-based evaluation approach, *IEEE Transaction on Fuzzy Systems* 9 (2001) 693–712.
- [243] J. Xu, C. Hang, C. Liu, Parallel structure and tuning of a fuzzy PID controller, *Automatica* 36 (2000) 673–684.
- [244] Z.Y. Zhao, M. Tomizuka, S. Isaka, Fuzzy gain scheduling of PID controllers, *IEEE Transactions on Systems Man and Cybernetics* 23 (1993) 1392–1398.
- [245] Bao-Gang, H.; Mann, G.K.I. & Gosine, R.G. New methodology for analytical and optimal design of fuzzy PID controllers, *IEEE Trans. On Fuzzy Systems*, Vol. 7, Issue 5, Oct. 1999, p. 521.
- [246] Bao-Gang, H., Mann, G.K.I. & Gosine, R.G. A systematic study of fuzzy PID controllers function based evaluation approach, *IEEE Trans. On Fuzzy Systems*, Vol. 9, Issue 5, Oct. 2001, p. 699.
- [247] Yame, J.J. Takagi-Sugeno fuzzy PI controllers: Analytical equivalence and tuning, *Journal A*, Vol. 42, no. 3, p. 13-57, 2001.

- [248] Xu; J.X.; Pok; Y.M.; Liu; C. & Hang, C.C. Tuning and analysis of a fuzzy PI controller based on gain and phase margins, *IEEE Transactions on Systems, Man and Cybernetics, Part A, Volume 28, Issue 5, Sept. 1998*, p. 685 – 691.
- [249] Ying, H. Mamdani Fuzzy PID Controllers, *Fuzzy Control and Modeling: Analytical Foundations and Applications, IEEE, 2000*.
- [250] Volosencu, C. Pseudo-Equivalence of Fuzzy PID Controllers, *WSEAS Transactions on Systems and Control, Issue 4, Vol. 4, April 2009*, p. 163-176.
- [251] Y. Zhao, E.G. Collins, Fuzzy PI control design for an industrial weigh belt feeder, *IEEE Transactions on Fuzzy Systems 3 (2003) 311–319*.
- [252] K. Pal, R.K. Mudi, N.R. Pal, A new scheme for fuzzy rule-based systems identification and its application to self tuning fuzzy controller, *IEEE Transactions on SMC Part B 32 (2002) 470–482*.
- [253] C.T. Chao, C.C. Teng, A PD-like self-tuning fuzzy controller without steady state error, *Fuzzy Sets and Systems 87 (1997) 141–154*.
- [254] J. Carvajal, G. Chen, H. Ogmen, Fuzzy PID controller: design performance evaluation and stability analysis, *Information Science 123 (2000) 249–270*.
- [255] Z.W. Woo, H.Y. Chung, J.J. Lin, A PID type fuzzy controller with self tuning scaling factors, *Fuzzy Sets and Systems 115 (2000) 321–326*.
- [256] Qiao, W. Z., & Mizumoto, M. (1996). PID type fuzzy parameters adaptive method. *Fuzzysets and Systems, 78, 23–35*.
- [257]]Kazemian, H. B. (2001). Comperative study of a learning fuzzy PID controller and a self-tuning controller. *ISA Transactions, 40, 245–253*.
- [258] Woo, Z. W., Chung, H. Y., & Lin, J. J. (2000). A PID type fuzzy controller with selftuning scaling factors. *Fuzzy Sets and Systems, 115, 321–326*.
- [259] A. Kanarachos, K. Geramanis, Multivariable control of single zone hydronic heating systems with neural networks, *Energy Conversion Management 13 (1998) 1317–1336*.
- [260] Q. J. Zhang and K. C. Gupta, *Neural Networks for RF and Microwave Design*. Norwood, MA: Artech House, 2000.
- [261] S. De, M. Kaiadi, M. Fast, M. Assadi, Development of an artificial neural network model for the steam process of a coal biomass cofired combined heat and power (CHP) plant in Sweden, *Energy 32 (2007) 2099-2109*.
- [262] J.W. Moon, J.J. Kim, ANN-based thermal control models for residential buildings, *Building and Environment 45 (2010) 1612-1625*.
- [263] D.L. Loveday, G.S. Virk, Artificial intelligence for buildings, *Applied Energy 41 (1992) 201-221*.
- [264] A.A. Argiriou, I. Bellas-Velidis, C.A. Balaras, Development of a neural network heating controller for solar buildings, *Neural Networks 13 (2000) 811-820*.
- [265] N. Morel, M. Bauer, M. El-Khoury, J. Krauss, Neurobat, a predictive and adaptive heating control system using artificial neural networks, *International Journal of Solar Energy 21 (2001) 161-201*.

- [266] M.S. Yeo, K.W. Kim, Application of artificial neural network to predict the optimal start time for heating system in building, *Energy Conversion and Management* 44 (2003) 2791-2809.
- [267] I.H. Yang, K.W. Kim, Development of artificial neural network model for the prediction of descending time of room air temperature, *International Journal of Air-Conditioning and Refrigeration* 12 (2000) 1038-1048.
- [268] K. C. Gupta, "Emerging trends in millimeter-wave CAD," *IEEE Trans. Microwave Theory Tech.*, vol. 46, pp. 747–755, June 1998.
- [269] V. K. Devabhaktuni, M. Yagoub, Y. Fang, J. Xu, and Q. J. Zhang, "Neural networks for microwave modeling: Model development issues and nonlinear modeling techniques," *Int. J. RF Microwave Computer-Aided Eng.*, vol. 11, pp. 4–21, 2001.
- [270] M. Vai and S. Prasad, "Microwave circuit analysis and design by a massively distributed computing network," *IEEE Trans. Microwave Theory Tech.*, vol. 43, pp. 1087–1094, May 1995.
- [271] M. Vai, S. Wu, B. Li, and S. Prasad, "Reverse modeling of microwave circuits with bidirectional neural network models," *IEEE Trans. Microwave Theory Tech.*, vol. 46, pp. 1492–1494, Oct. 1998.
- [272] J. A. Jargon, K. C. Gupta, and D. C. DeGroot, "Applications of artificial neural networks to RF and microwave measurements," *Int. J. RF Microwave Computer-Aided Eng.*, vol. 12, pp. 3–24, 2002.
- [273] P. M. Watson, C. Cho, and K. C. Gupta, "Electromagnetic-artificial neural network model for synthesis of physical dimensions for multilayer asymmetric coupled transmission structures," *Int. J. RF Microwave Computer-Aided Eng.*, vol. 9, pp. 175–186, 1999.
- [274] V. K. Devabhaktuni, M. Yagoub, and Q. J. Zhang, "A robust algorithm for automatic development of neural-network models for microwave applications," *IEEE Trans. Microwave Theory Tech.*, vol. 49, pp. 2282–2291, Dec. 2001.
- [275] T. Y. Kwok and D. Y. Yeung, "Constructive algorithms for structure learning in feedforward neural networks for regression problems," *IEEE Trans. Neural Networks*, vol. 8, pp. 630–645, May 1997.
- [276] J. de Villiers and E. Barnard, "Backpropagation neural nets with one and two hidden layers," *IEEE Trans. Neural Networks*, vol. 4, pp. 136–141, Jan. 1992.
- [277] [277]F. Wang, V. K. Devabhaktuni, C. Xi, and Q. J. Zhang, "Neural network structures and training algorithms for microwave applications," *Int. J. RF Microwave Computer-Aided Eng.*, vol. 9, pp. 216–240, 1999.
- [278] C. Bishop, *Neural Networks for Pattern Recognition*. London, U.K.: Oxford Univ. Press, 1995.
- [279] D. Du and D. Sun, "Comparison of three methods for classification of pizza topping using different color space transformations," *J. Food Eng.*, vol. 68, no. 3, pp. 277–287, 2005.

- [280] Q. Li, X. Chen, and Z. Hu, "Quantitative structure-property relationship studies for estimating boiling points of alcohols using calculated molecular descriptors with radial basis function neural networks," *Chemometrics Intell. Lab. Syst.*, vol. 72, no. 1, pp. 93–100, 2004.
- [281] H. Liu, R. Zhang, X. Yao, M. Liu, Z. Hu, and B. Fan, "Prediction of electrophoretic mobility of substituted aromatic acids in different aqueous—Alcoholic solvents by capillary zone electrophoresis based on support vector machine," *Analytica Chimica Acta*, vol. 525, no. 1, pp. 31–41, 2004.
- [282] S. Chen, C.F. Cowan, and P. M. Grant, "Orthogonal least squares learning algorithm for radial basis function networks," *IEEE Trans. Neural Netw.*, vol. 2, no. Mar., pp. 302–309, 1991.
- [283] W. Pedrycz, "Conditional fuzzy clustering in the design of radial basis function neural networks," *IEEE Trans. Neural Netw.*, vol. 9, no. 4, pp. 601–612, Jul. 1998.
- [284] N. W. Townsend and L. Tarassenko, "Estimations of error bounds for neural-network function approximators," *IEEE Trans. Neural Netw.*, vol. 10, no. 2, pp. 217–230, Mar. 1999.
- [285] W. Kaminski and P. Strumillo, "Kernel orthonormalization in radial basis function neural networks," *IEEE Trans. Neural Netw.*, vol. 8, no. 5, pp. 1177–1183, Sep. 1997.
- [286] K. Z. Mao, "RBF neural network center selection based on Fisher ratio class separability measure," *IEEE Trans. Neural Netw.*, vol. 13, no. 5, pp. 1211–1217, Sep. 2002.
- [287] A. Alexandridis, P. Patrinos, H. Sarimveis, and G. Tsekouras, "A twostage evolutionary algorithm for variable selection in the development of RBF neural network models," *Chemo. Intell. Lab. Syst.*, vol. 75, no. 2, pp. 149–162, 2005.
- [288] V. M. Rivas, J. J. Merelo, P. A. Castillo, M. G. Arenas, and J. G. Castellano, "Evolving RBF neural networks for time-series forecasting with EvRBF," *Inf. Sci.*, vol. 165, no. 3–4, pp. 207–220, 2004.
- [289] Y. Fang, M. Yagoub, F. Wang, and Q. J. Zhang, "A new macro-modeling approach for nonlinear microwave circuits based on recurrent neural networks," *IEEE Trans. Microwave Theory Tech.*, vol. 48, pp. 2335–2344, Dec. 2000.
- [290] J. Xu, M. Yagoub, R. Ding, and Q. J. Zhang, "Neural-based dynamic modeling of nonlinear microwave circuits," *IEEE Trans. Microwave Theory Tech.*, vol. 50, pp. 2769–2780, Dec. 2002.
- [291] F. Wang and Q. J. Zhang, "Knowledge-based neural models for microwave design," *IEEE Trans. Microwave Theory Tech.*, vol. 45, pp. 2333–2343, Dec. 1997.
- [292] J.S.R. Jang, C.T. Sun, E. Mizutani, *Neuro-fuzzy and soft computing*, Prentice Hall, 1996.

- [293] C.P. Kurian, S. Kuriachan, J. Bhat, R.S. Aithal, An adaptive neuro-fuzzy model for the prediction and control of light in integrated lighting schemes, *Lighting Research and Technology* 37 (2005) 343–352.
- [294] A. Argiriou, I. Bellas-Velidis, M. Kummert, P. Andre, A neural network controller for hydronic heating systems of solar buildings, *Neural Networks* 17 (2004) 427–440.
- [295] B. Egilegor, J.P. Uribe, G. Arregi, E. Pradilla, L. Susperregi, A fuzzy control adapted by a neural network to maintain a dwelling within thermal comfort, In: *5th international97*, 1997.
- [296] F. Yamada, K. Yonezawa, S. Sugarawa, N. Nishimura, Development of air-conditioning control algorithm for building energy –saving, In: *IEEE international conference on control applications*, 1999.
- [297] S. Ari, I.A. Cosden, H.E. Khalifa, J.F. Dannenhoffer, P. Wilcoxon, C. Isik, Constrained fuzzy logic approximation for indoor comfort and energy optimisation, In: *Annual conference of the North American Fuzzy Information Processing Society—NAFIPS*, (2005) 500–504 [Article number 1548586].
- [298] Z. Michalewicz, *Genetic algorithms + data structures = evolution programs*. Springer, 1999.
- [299] R. Alcalá, J.M. Benitez, J. Casillas, O. Cordon, R. Perez, Fuzzy control of HVAC systems optimized by genetic algorithms, *Applied Intelligence* 18 (2003) 155–177.
- [300] H.N. Lam, Intelligent computer control of air conditioning systems based on genetic algorithms and classifier system, *Building Simulation* (1995) 151–157.
- [301] Heat transfer coefficient. http://en.wikipedia.org/wiki/Heat_transfer_coefficient. (accessed 24/05/2014)
- [302] Tools and Basic Information for Design, Engineering and Construction of Technical Applications. <http://www.engineeringtoolbox.com/> (accessed 24/05/2014)
- [303] Altinten, A., Erdogan, H., Hapoglu, F., Aliev, F., Alpbaz, M., (2006) application of fuzzy control method with genetic algorithm to a polymerization reactor at constant set point, *Chemical engineering research and design*, 84(A11), pp. 1012-1018
- [304] Hui, P.S., Wong, L.T. and Mui, K.W. 2006. Feasibility study of an express assessment protocol for the indoor air quality of air-conditioned offices, *Indoor and Built Environment*, 15(4), 373–378.
- [305] [305]Hornik, K., Stinchcombe, M. and White, H. 1989. Multilayer feedforward networks are universal approximators, *Neural Networks* 2(5), 359–366.
- [306] Cybenko, G. 1989. Approximation by superpositions of a sigmoidal function, *Math.Control Signals Syst. (MCSS)*, (2), 303–314.
- [307] Ken-Ichi, F. 1989. On the approximate realization of continuous mappings by neural networks, *Neural Networks* 2(3), 183–192.

- [308] Qiu, Z., Wang, X., Gao, Q. Temperature and Humidity Precise Control of Greenhouse Based on Nonlinear Model, International Asia Conference on Industrial Engineering and Management Innovation (IEMI2012) Proceedings (2013) pp:805-814
- [309] Advanced Temperature Controller and Programmer. <http://www.eurotherm.co.uk/en-gb/products/controllers/multi-loop/3500/3504/>. (accessed 29/05/2014)
- [310] Instrument driver network. http://sine.ni.com/apps/utf8/niid_web_display.model_page?p_model_id=2439. (accessed 15/06/2012)
- [311] ASHRAE, ASHRAE standard 55-2010. In: Thermal environmental conditions for human occupancy. ASHRAE Atlanta, GA; 2010.

Appendix

Appendix A Matlab code of fuzzy-PID control

%Fuzzy Tunning PID Control

clear all;

close all;

a=newfis('fuzzpid');

a=addvar(a,'input','e',[-3,3]);

%Parameter e

a=addmf(a,'input',1,'NB','zmf',[-3,-1]);

a=addmf(a,'input',1,'NM','trimf',[-3,-2,0]);

a=addmf(a,'input',1,'NS','trimf',[-3,-1,1]);

a=addmf(a,'input',1,'Z','trimf',[-2,0,2]);

a=addmf(a,'input',1,'PS','trimf',[-1,1,3]);

a=addmf(a,'input',1,'PM','trimf',[0,2,3]);

a=addmf(a,'input',1,'PB','smf',[1,3]);

a=addvar(a,'input','ec',[-3,3]);

%Parameter ec

a=addmf(a,'input',2,'NB','zmf',[-3,-1]);

a=addmf(a,'input',2,'NM','trimf',[-3,-2,0]);

a=addmf(a,'input',2,'NS','trimf',[-3,-1,1]);

a=addmf(a,'input',2,'Z','trimf',[-2,0,2]);

a=addmf(a,'input',2,'PS','trimf',[-1,1,3]);

a=addmf(a,'input',2,'PM','trimf',[0,2,3]);

a=addmf(a,'input',2,'PB','smf',[1,3]);

a=addvar(a,'output','kp',[-0.3,0.3]);

%Parameter kp

a=addmf(a,'output',1,'NB','zmf',[-0.3,-0.1]);

a=addmf(a,'output',1,'NM','trimf',[-0.3,-0.2,0]);

a=addmf(a,'output',1,'NS','trimf',[-0.3,-0.1,0.1]);

a=addmf(a,'output',1,'Z','trimf',[-0.2,0,0.2]);

a=addmf(a,'output',1,'PS','trimf',[-0.1,0.1,0.3]);

a=addmf(a,'output',1,'PM','trimf',[0,0.2,0.3]);

a=addmf(a,'output',1,'PB','smf',[0.1,0.3]);

a=addvar(a,'output','ki',[-0.06,0.06]);

%Parameter ki

a=addmf(a,'output',2,'NB','zmf',[-0.06,-0.02]);

a=addmf(a,'output',2,'NM','trimf',[-0.06,-0.04,0]);

a=addmf(a,'output',2,'NS','trimf',[-0.06,-0.02,0.02]);

a=addmf(a,'output',2,'Z','trimf',[-0.04,0,0.04]);

a=addmf(a,'output',2,'PS','trimf',[-0.02,0.02,0.06]);

a=addmf(a,'output',2,'PM','trimf',[0,0.04,0.06]);

```
a=addmf(a,'output',2,'PB','smf',[0.02,0.06]);
```

```
a=addvar(a,'output','kd',[-3,3]);
```

%Parameter kp

```
a=addmf(a,'output',3,'NB','zmf',[-3,-1]);
```

```
a=addmf(a,'output',3,'NM','trimf',[-3,-2,0]);
```

```
a=addmf(a,'output',3,'NS','trimf',[-3,-1,1]);
```

```
a=addmf(a,'output',3,'Z','trimf',[-2,0,2]);
```

```
a=addmf(a,'output',3,'PS','trimf',[-1,1,3]);
```

```
a=addmf(a,'output',3,'PM','trimf',[0,2,3]);
```

```
a=addmf(a,'output',3,'PB','smf',[1,3]);
```

```
rulelist= [1 1 7 1 5 1 1;  
           1 2 7 1 3 1 1;  
           1 3 6 2 1 1 1;  
           1 4 6 2 1 1 1;  
           1 5 5 3 1 1 1;  
           1 6 4 4 2 1 1;  
           1 7 4 4 5 1 1;
```

```
           2 1 7 1 5 1 1;  
           2 2 7 1 3 1 1;  
           2 3 6 2 1 1 1;  
           2 4 5 3 2 1 1;  
           2 5 5 3 2 1 1;  
           2 6 4 4 3 1 1;  
           2 7 3 4 4 1 1;
```

```
           3 1 6 1 4 1 1;  
           3 2 6 2 3 1 1;  
           3 3 6 3 2 1 1;  
           3 4 5 3 2 1 1;  
           3 5 4 4 3 1 1;  
           3 6 3 5 3 1 1;  
           3 7 3 5 4 1 1;
```

```
           4 1 6 2 4 1 1;  
           4 2 6 2 3 1 1;  
           4 3 5 3 3 1 1;  
           4 4 4 4 3 1 1;  
           4 5 3 5 3 1 1;  
           4 6 2 6 3 1 1;  
           4 7 2 6 4 1 1;
```

```

5 1 5 2 4 1 1;
5 2 5 3 4 1 1;
5 3 4 4 4 1 1;
5 4 3 5 4 1 1;
5 5 3 5 4 1 1;
5 6 2 6 4 1 1;
5 7 2 7 4 1 1;

6 1 5 4 7 1 1;
6 2 4 4 5 1 1;
6 3 3 5 5 1 1;
6 4 2 5 5 1 1;
6 5 2 6 5 1 1;
6 6 2 7 5 1 1;
6 7 1 7 7 1 1;

7 1 4 4 7 1 1;
7 2 4 4 6 1 1;
7 3 2 5 6 1 1;
7 4 2 6 6 1 1;
7 5 2 6 5 1 1;
7 6 1 7 5 1 1;
7 7 1 7 7 1 1];

```

```

a=addrule(a,rulelist);
a=setfis(a,'DefuzzMethod','centroid');
writefis(a,'fuzzpid');

```

```

a=readfis('fuzzpid');

```

```

%PID Controller

```

```

ts=0.001;
sys=tf(0.028,[506.52,1]);
sys1 = 10^6;
sys = sys*sys1;
dsys=c2d(sys,ts,'tustin');
[num,den]=tfdata(dsys,'v');

```

```

u_1=0.0;u_2=0.0;u_3=0.0;

```

```

y_1=0;y_2=0;y_3=0;

```

```

x=[0,0,0]';

error_1=0;
e_1=0.0;
ec_1=0.0;
ec = gradient(error);

kp0=0.3;
kd0=2.0;
ki0=0.0;

for k=1:1:500
time(k)=k*ts;

rin(k)=5;

%Using fuzzy inference to tuning PID
k_pid=evalfis([e_1,ec_1],a);
kp(k)=kp0+k_pid(1);
ki(k)=ki0+k_pid(2);
kd(k)=kd0+k_pid(3);
u(k)=kp(k)*x(1)+kd(k)*x(2)+ki(k)*x(3);

if u(k)>=10
    u(k)=10;
end
if u(k)<=-10
    u(k)=-10;
end

yout(k)=-den(2)*y_1+num(1)*u(k)+num(2)*u_1;

error(k)=rin(k)-yout(k);
%%%%%%%%%%%%Return of PID parameters%%%%%%%%
    u_3=u_2;
    u_2=u_1;
    u_1=u(k);

    y_3=y_2;

```

```

y_2=y_1;
y_1=yout(k);

x(1)=error(k);           % Calculating P
x(2)=error(k)-error_1;  % Calculating D
x(3)=x(3)+error(k);     % Calculating I

e_1=x(1);
ec_1=x(2);

error_2=error_1;
error_1=error(k);

end
showrule(a)
figure(1);plot(time,rin,'b',time,yout,'r');
xlabel('time(s)');ylabel('T(C)');
figure(2);plot(time,error,'r');
xlabel('time(s)');ylabel('error(C)');
figure(3);plot(time,u,'r');
xlabel('time(s)');ylabel('PID output');
figure(4)
subplot(3,1,1);
plot(time,kp,'r');
xlabel('time(s)');ylabel('kp');
subplot(3,1,2);
plot(time,ki,'b');
xlabel('time(s)');ylabel('ki');
subplot(3,1,3);
plot(time,kd,'g');
xlabel('time(s)');ylabel('kd');
figure(5)
subplot(3,1,1);
plot(error,kp,'r');
xlabel('error');ylabel('kp');
subplot(3,1,2);
plot(error,ki,'b');
xlabel('error');ylabel('ki');
subplot(3,1,3);
plot(error,kd,'g');
xlabel('error');ylabel('kd');
figure(6)

```

```
subplot(3,1,1);
plot(ec,kp,'r');
xlabel('ec');ylabel('kp');
subplot(3,1,2);
plot(ec,ki,'b');
xlabel('ec');ylabel('ki');
subplot(3,1,3);
plot(ec,kd,'g');
xlabel('ec');ylabel('kd');
figure(7);plotmf(a,'input',1);
figure(8);plotmf(a,'input',2);
figure(9);plotmf(a,'output',1);
figure(10);plotmf(a,'output',2);
figure(11);plotmf(a,'output',3);
plotfis(a);
fuzzy fuzzpid
```

Appendix B Matlab code of RBFNN-PID control

```
%PID control based on RBF neural network
```

```
clear all;
```

```
close all;
```

```
xite=0.25;
```

```
alfa=0.05;
```

```
belte=0.01;
```

```
x=[0,0,0]';
```

```
ci=30*ones(3,6);
```

```
bi=40*ones(6,1);
```

```
w=10*ones(6,1);
```

```
h=[0,0,0,0,0,0]';
```

```
ci_1=ci;ci_3=ci_1;ci_2=ci_1;
```

```
bi_1=bi;bi_2=bi_1;bi_3=bi_2;
```

```
w_1=w;w_2=w_1;w_3=w_1;
```

```
u_1=0;y_1=0;
```

```
xc=[0,0,0]';
```

```
error_1=0;error_2=0;error=0;
```

```
%kp=rand(1);
```

```
%ki=rand(1);
```

```
%kd=rand(1);
```

```
kp0=0.3;
```

```
ki0=0.01;
```

```
kd0=1;
```

```
kp_1=kp0;
```

```
kd_1=kd0;
```

```
ki_1=ki0;
```

```
xitekp=0.20;
```

```
xitekdp=0.20;
```

```
xiteki=0.20;
```

```
ts=0.001;
```

```
for k=1:1:2000
```



```

time(k)=k*ts;

S=2
if S==1
rin(k)=0.5;
elseif S==2
rin(k)=1.0*sign(sin(2*pi*k*ts));
end

yout(k)=(y_1+0.11*u_1)/(1+y_1^2); %Nonlinear humidity model

for j=1:1:6
    h(j)=exp(-norm(x-ci(:,j))^2/(2*bi(j)*bi(j)));
end
ymout(k)=w'*h;

d_w=0*w;
for j=1:1:6
    d_w(j)=xite*(yout(k)-ymout(k))*h(j);
end
w=w_1+d_w+alfa*(w_1-w_2)+belte*(w_2-w_3);

d_bi=0*bi;
for j=1:1:6
    d_bi(j)=xite*(yout(k)-ymout(k))*w(j)*h(j)*(bi(j)^-3)*norm(x-ci(:,j))^2;
end
bi=bi_1+d_bi+alfa*(bi_1-bi_2)+belte*(bi_2-bi_3);
for j=1:1:6
    for i=1:1:3
        d_ci(i,j)=xite*(yout(k)-ymout(k))*w(j)*h(j)*(x(i)-ci(i,j))*(bi(j)^-2);
    end
end
ci=ci_1+d_ci+alfa*(ci_1-ci_2)+belte*(ci_2-ci_3);

%%%%%%%%%%%%%%%%%%%%%%%%%%%%%%%%%%%%%%%%%%%%%%%%%%%%%%%%%%%%%%%%%%%%%%%%Jacobian%%%%%%%%%%%%%%%%%%%%%%%%%%%%%%%%%%%%%%%%%%%%%%%%%%%%%%%%%%%%%%%%%%%%%%%%
yu=0;
for j=1:1:6
    yu=yu+w(j)*h(j)*(-x(1)+ci(1,j))/bi(j)^2;
end
dyout(k)=yu;

```



```

        error_2=error_1;
error_1=error(k);

kp_1=kp(k);
kd_1=kd(k);
ki_1=ki(k);
end

figure(1);
plot(time,rin,'b',time,yout,'r');
xlabel('time(s)');ylabel('H%');
figure(2);
plot(time,u);
xlabel('time(s)');ylabel('PID output');
figure(3); %Plot Jacobian
plot(time,dyout);
xlabel('time(s)');ylabel('Jacobian value');
figure(4);
subplot(3 1 1);
plot(time,kp,'r');
xlabel('time(s)');ylabel('kp');
subplot(3 1 2);
plot(time,ki,'b');
xlabel('time(s)');ylabel('ki');
subplot(3 1 3);
plot(time,kd,'g');
xlabel('time(s)');ylabel('kd');
figure(5);
subplot(3 1 1);
plot(dyout,kp,'r');
xlabel('Jacobian');ylabel('kp');
subplot(3 1 2);
plot(dyout,ki,'b');
xlabel('Jacobian');ylabel('ki');
subplot(3 1 3);
plot(dyout,kd,'g');
xlabel('Jacobian');ylabel('kd');
figure(6);
plot(time,yout,'r',time,ymout,'b');
xlabel('time(s)');ylabel('y,ym');

```

Appendix C Matlab code of BPNN-PID control

```
%PID Control based on BPNN
clear all;
close all;

xite=0.28;
alfa=0.04;

IN=4;H=5;Out=3; %NN Structure

%wi= random [-0.5,0.5];
wi=[-0.4394 -0.2696 -0.3756 -0.4023;
    -0.4603 -0.2013 -0.3024 -0.2596;
    -0.4749 0.4543 -0.3820 -0.2437;
    -0.3625 -0.4724 -0.3463 -0.2859;
    0.1425 0.4279 -0.2406 -0.4660];

wi_1=wi;wi_2=wi;wi_3=wi;
wo=[0.3576 0.2616 0.2820 -0.1416 -0.1325;
    -0.1146 0.2949 0.1352 0.2205 0.4508;
    0.3201 0.4566 0.3672 0.4962 0.3632];
%wo= random[-0.5,0.5];
wo_1=wo;wo_2=wo;wo_3=wo;

x=[0,0,0];
du_1=0;
u_1=0;u_2=0;u_3=0;u_4=0;u_5=0;
y_1=0;y_2=0;y_3=0;

Oh=zeros(H,1); %Output from NN hidden layer
I=Oh; %Input to NN hidden layer
error_2=0;
error_1=0;

ts=0.001;
for k=1:1:1000
time(k)=k*ts;

rin(k)=1.0;
```

```

%nonlinear model
a(k)=1.4*(1-0.8*exp(-0.1*k));
yout(k)=a(k)*y_1/(1+y_1^2)+u_1;

error(k)=rin(k)-yout(k);

xi=[rin(k),yout(k),error(k),1];

x(1)=error(k)-error_1;
x(2)=error(k);
x(3)=error(k)-2*error_1+error_2;

epid=[x(1);x(2);x(3)];
I=xi*wi';
for j=1:1:H
    Oh(j)=(exp(I(j))-exp(-I(j)))/(exp(I(j))+exp(-I(j))); %hidden Layer
end
K=wo*Oh; %Output Layer
for l=1:1:Out
    K(l)=exp(K(l))/(exp(K(l))+exp(-K(l))); %Getting kp,ki,kd
end
kp(k)=K(1);ki(k)=K(2);kd(k)=K(3);
Kpid=[kp(k),ki(k),kd(k)];

du(k)=Kpid*epid;
u(k)=u_1+du(k);

dyu(k)=sign((yout(k)-y_1)/(du(k)-du_1+0.0001));

%Output layer
for j=1:1:Out
    dK(j)=2/(exp(K(j))+exp(-K(j)))^2;
end
for l=1:1:Out
    delta3(l)=error(k)*dyu(k)*epid(l)*dK(l);
end

for l=1:1:Out
    for i=1:1:H
        d_wo=xite*delta3(l)*Oh(i)+alfa*(wo_1-wo_2);
    end
end
end

```

```

        wo=wo_1+d_wo+alfa*(wo_1-wo_2);
%Hidden layer
for i=1:1:H
    dO(i)=4/(exp(I(i))+exp(-I(i)))^2;
end
    segma=delta3*wo;
for i=1:1:H
    delta2(i)=dO(i)*segma(i);
end

d_wi=xite*delta2'*xi;
wi=wi_1+d_wi+alfa*(wi_1-wi_2);

%Parameters Update
du_1=du(k);
u_5=u_4;u_4=u_3;u_3=u_2;u_2=u_1;u_1=u(k);
y_2=y_1;y_1=yout(k);

wo_3=wo_2;
wo_2=wo_1;
wo_1=wo;

wi_3=wi_2;
wi_2=wi_1;
wi_1=wi;

error_2=error_1;
error_1=error(k);
end

ec = gradient(error);

figure(1);
plot(time,rin,'r',time,yout,'b');
xlabel('time(s));ylabel('CO2');
figure(2);
plot(time,error,'r');
xlabel('time(s));ylabel('error');
figure(3);
plot(time,u,'r');
xlabel('time(s));ylabel('PID output');
figure(4);

```

```

subplot(311);
plot(time,kp,'r');
xlabel('time(s)');ylabel('kp');
subplot(312);
plot(time,ki,'g');
xlabel('time(s)');ylabel('ki');
subplot(313);
plot(time,kd,'b');
xlabel('time(s)');ylabel('kd');
figure(5);
subplot(311);
plot(error,kp,'r');
xlabel('error');ylabel('kp');
subplot(312);
plot(error,ki,'g');
xlabel('error');ylabel('ki');
subplot(313);
plot(error,kd,'b');
xlabel('error');ylabel('kd');
figure(6);
subplot(311);
plot(ec,kp,'r');
xlabel('ec');ylabel('kp');
subplot(312);
plot(ec,ki,'g');
xlabel('ec');ylabel('ki');
subplot(313);
plot(ec,kd,'b');
xlabel('ec');ylabel('kd');
figure(7);
subplot(311);
plot(u,kp,'r');
xlabel('u');ylabel('kp');
subplot(312);
plot(u,ki,'g');
xlabel('u');ylabel('ki');
subplot(313);
plot(u,kd,'b');
xlabel('u');ylabel('kd');
figure(8);
subplot(311);
plot(yout,kp,'r');

```

```
xlabel('yout');ylabel('kp');  
subplot(312);  
plot(yout,ki,'g');  
xlabel('yout');ylabel('ki');  
subplot(313);  
plot(yout,kd,'b');  
xlabel('y');ylabel('kd');
```

(2) Part 2: part of the Eurotherm PID program; connects to Part 1 and Part 3

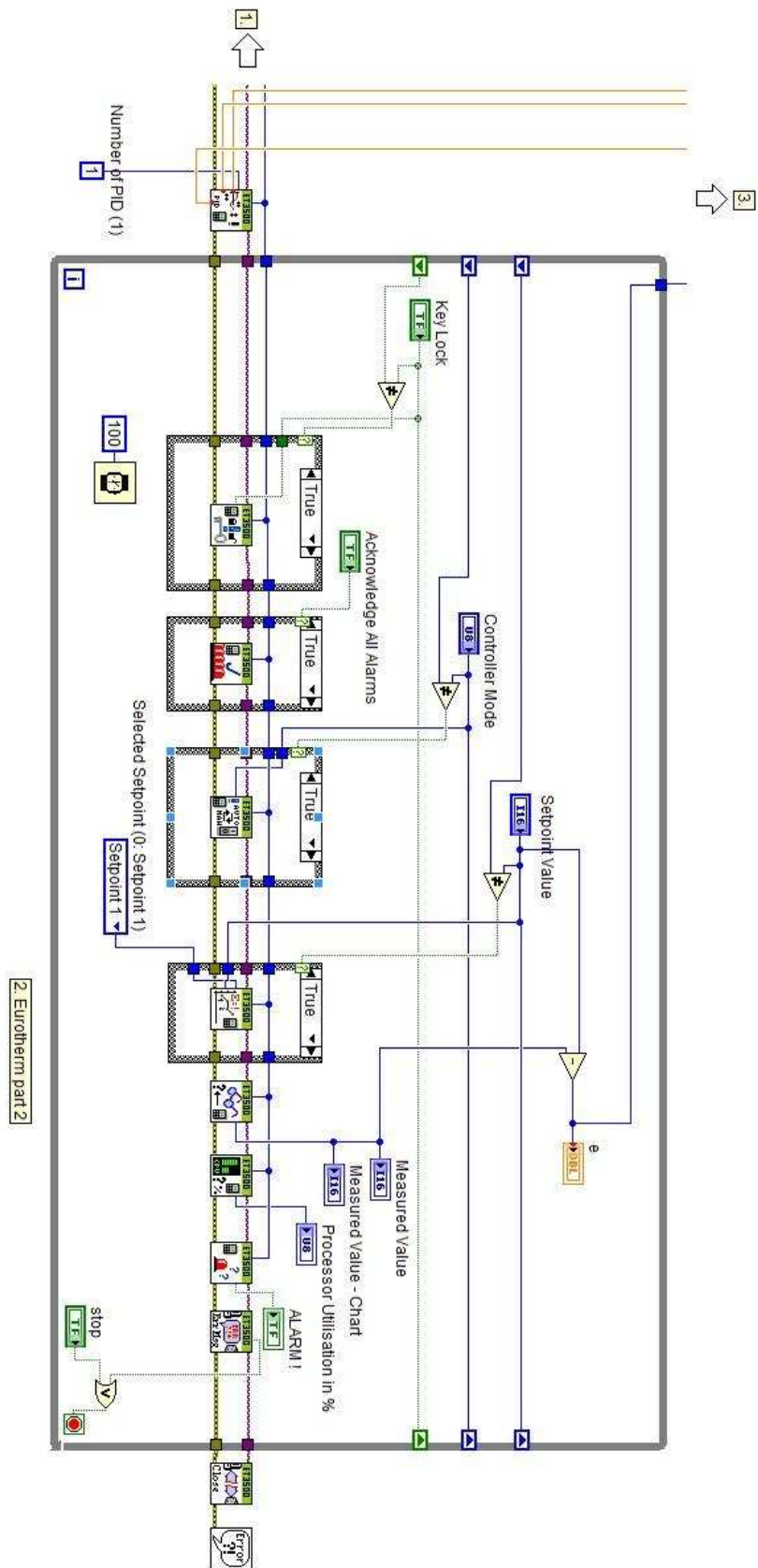

(3) Part 3: fuzzy logic control program; connects to Part2

