



The University of
Nottingham

UNITED KINGDOM • CHINA • MALAYSIA

Riley, Paul Howard (2014) Designing a low-cost electricity-generating cooking stove for high-volume implementation. PhD thesis, University of Nottingham.

Access from the University of Nottingham repository:

http://eprints.nottingham.ac.uk/13961/1/PHRthesisfor_PhDfinal.pdf

Copyright and reuse:

The Nottingham ePrints service makes this work by researchers of the University of Nottingham available open access under the following conditions.

This article is made available under the University of Nottingham End User licence and may be reused according to the conditions of the licence. For more details see:
http://eprints.nottingham.ac.uk/end_user_agreement.pdf

A note on versions:

The version presented here may differ from the published version or from the version of record. If you wish to cite this item you are advised to consult the publisher's version. Please see the repository url above for details on accessing the published version and note that access may require a subscription.

For more information, please contact eprints@nottingham.ac.uk



The University of
Nottingham

UNITED KINGDOM • CHINA • MALAYSIA

DESIGNING A LOW-COST
ELECTRICITY-GENERATING COOKING STOVE
FOR HIGH-VOLUME IMPLEMENTATION

by

PAUL HOWARD RILEY

Thesis submitted
for the degree of Doctor of Philosophy to
the University of Nottingham

Completed 26 July 2013

ABSTRACT

Short Abstract:

This PhD describes the social science and technical design of an innovative clean cooking stove that also generates electricity for use in developing countries. Key areas of learning adding to the research pool are:

1. Method for comparing costs of competing designs early in the research process before detailed design has been undertaken.
2. Use of state-of-the-art industrial design processes combined with social science investigations to direct research to meet end-user needs
3. Design of a low-cost, low thermal mass hot heat exchanger for use in thermo-acoustic engines
4. Design of a low-cost, low-mass Linear Alternator suitable for use in thermo-acoustic engines
5. Half-wave thermo-acoustic engine configuration with low-onset temperature suitable for operation with wood or dung as the fuel.
6. Use of an electrical analogue to predict unusual thermo-acoustic behaviour such as squegging and time-based pressure variations.

The document is an extended abstract pulling together Riley's 6 years of research and publications from the Score project, into one coherent theme as required by the University of Nottingham quality manual for staff engaged in research.

The document describes the background of thermo-acoustics and how the project has enabled the science to progress from mainly rig-based engines to a manufacturable product. The research management process and techniques used to reduce project risk are highlighted, beginning with social science research into end-user requirements, system design, component design, testing and production cost predictions.

LIST OF PUBLICATIONS

Publications

Peer reviewed Journals, (Where Riley was the major contributor to knowledge)

[1] Riley, P.H., and Johnson, C.M., “Designing a Low-Cost, Electricity Generating Cooking Stove”, *Technology and Society Magazine IEEE*, summer 2010. Digital Object Identifier 10.1109/MTS.2010.937029, 1932-4529/10/\$26.00©2010IEEE.

[2] Saha, C.R., Riley, P.H., Johnson, C.M., Paul J., Yu, Z., Jaworski, A. “Halbach array Linear Alternator for thermo-acoustic engine” *Sensors & Actuators: A. Physical.*: 4-Mar-2012 DOI information: <http://dx.doi.org/10.1016/j.sna.2012.01.042>

[3] Chen, B., Abdalla Abakr, Y., Riley, PH., Hann, D., “Investigation and Measurement of a Low-cost Loudspeaker as a Liner Alternation for Thermoacoustic Application. *Applied Mechanics and Materials*”, 2011(submitted paper).

[4] Chen, B., Abdalla Abakr, Y., Riley, PH., Hann, D., “Development of thermoacoustic engine operating by waste heat from cooking stove “ *AIP Conf. Proc.* 1440, pp. 532-540; doi:<http://dx.doi.org/10.1063/1.4704259> (9 pages)

[5] Riley, Paul H. "Towards a Transient Simulation of thermo-acoustic Engines Using an Electrical Analogy." *Procedia Engineering* 56 (2013): 821-828.

[6] B M Chen, P H Riley, Y A Abakr, K Pullen, D B Hann, and C M Johnson, Design and development of a low-cost, electricity-generating cooking Score-Stove™ *Proceedings of the Institution of Mechanical Engineers, Part A: Journal of Power and Energy* 0957650913498733, first published on September 5, 2013 as doi:10.1177/0957650913498733.

[7] Riley, PH., “Affordability for sustainable energy development products”, paper submitted to *Journal of Applied energy*.

Conference Papers, (Where Riley was a major contributor)

[8] Riley, PH., and Johnson, CM., “Generating electricity in developing countries using thermo-acoustics powered by burning wood”, *Acoustics 08*, Paris, June 2008.

[9] Riley, PH., and Johnson, CM., Saha, C.R., “Investigation of thermo-acoustically Driven Linear Alternator” *U21 Energy conference*, Birmingham UK, Sept 2008.

[10] Riley P.H., Saha C., Johnson CM., Presentation to the UK Parliamentary committee Dec 2009. <http://www.parliament.uk/documents/upload/riley.pdf>

[11] Riley P.H, Saha C., Johnson CM., “Application of Thermo-acoustic, electrical generating engines in rural areas”, *IIT Delhi* 7-9 September 2010.

[12] Chen, B., Riley, PH., et al., “Design and Testing of a Wood Burning Electricity Generator by using Dual-Core Thermoacoustic Engine”. *2011 World Congress on Engineering and Technology (CET)*, Shanghai, China, 2011.

[13] Chen, B., Riley, PH., and Abakr, YA., “Construction and Assessment of a Propane driven, Electricity-Generating Cooking Score-Stove™” in International congress on Green process Engineering 2011: Kuala Lumpur Malaysia.

[14] Chen, B., Abdalla Abakr, Y., Riley, PH., Hann, D., “Development of Thermoacoustic Engine Operating by Waste Heat from Cooking Stove”. International Meeting of Advances in Thermofluids 4th IMAT 2011. 2011: Melaka.

[15] S.T. Wee, D.B. Hann, P. H. Riley, and Y. A. Abakr, “Improvement of the Travelling Wave Thermoacoustic Engine Feedback Loop”, International congress on Green process Engineering 2011: Kuala Lumpur, Malaysia.

[16] Chen, B., Abdalla Abakr, Y., Riley, PH., Hann, D., “Investigation and Measurement of a Low-cost Loudspeaker as a Liner Alternation for Thermoacoustic Application”. 2011 International Conference on Applied Mechanics, Materials and Manufacturing. 2011: Shenzhen, China.

[17] Riley P.H. “Low-cost, electricity generating heat engines for rural areas”. International conference on Low-cost, electricity generating heat engines for rural areas. 2 3 April 2012 Nottingham UK.

[18] Chen, B., Abdalla Abakr, Y., Riley, PH., Hann, D., “Development and Assessment of a Score Demo2.1 thermo-acoustic Engine”, International conference on low-cost, electricity generating heat engines for rural areas. 2 3 April 2012 Nottingham UK.

[19] Saha, C., Riley, PH., and Johnson, CM., “Analysis of the effects of different types of loads on a thermo-acoustic Engine”. International conference on low-cost, electricity generating heat engines for rural areas. 2 3 April 2012 Nottingham UK.

Other supporting documentation to add context,

(Where Riley was the main contributor)

[20] Score Project Plan

[21] Score CA agreement

[22] Score Intellectual Property Agreement

[23] Score External Collaborators Agreement. (Template)

[24] Patent: heat exchanger arrangement

[25] Patent: Linear Alternator.

[26] Module1: the Score story

[27] Module2: thermo-acoustic background

[28] Score web site www.Score.uk.com

[29] Community web site working practices document.
<http://www.Score.uk.com/community/Shared%20Documents/SharePointworkingpractices.doc>

[30] Riley PH., Saha C., Demo2 Installation Document.

ACKNOWLEDGEMENTS

Acknowledgements

The author wishes to express sincere appreciation to:

Dr David Hann who found the means and gave me the confidence to undertake this PhD submission.

The core Score team, Community and Score-Centre staff for their continued support.

My advisor Professor Steve Morgan for his patience and for guiding me through the PhD process.

My wife Gill and Bekki Burns for help with Proof reading.

TABLE OF CONTENTS

Contents

Short Abstract:.....	1
Publications	2
Peer reviewed Journals, (Where Riley was the major contributor to knowledge).....	2
Conference Papers, (Where Riley was a major contributor)	2
Other supporting documentation to add context, (Riley was the main contributor)	3
Acknowledgements	4
Chapter 1 Introduction.....	9
Basis of this PhD submission.....	9
Previous research.....	9
Background and context.....	10
Problem and overview.....	11
Project Management	11
Social	11
Thermo-acoustics	11
Score Research Objectives.....	12
Score Consortium	13
Web site and publicity.....	13
Project Management.....	13
Chapter 2 Requirements Capture	15
Social requirements verification	16
Technical requirements verification	16
Chapter 3 System Design	18
Cost comparison evaluation method.....	18
System cost optimisation	19
Material cost	19
Energy Flows.....	19
Linear Alternator cost trade-off	20
Wave type.....	21
Number of regenerators.....	21
Dual regenerator design	21
Chapter 4 system analysis and simulation	23
Background.....	23
Laboratory to real product	23
Conclusions	23
Chapter 5 COMPONENT design.....	24
Background.....	24
Heat exchangers	24
Ambient heat exchanger(AHX).....	25
Hot Heat Exchanger (HHX)	25
Linear Alternator performance optimisation	26
Matching LA with the acoustics.....	26
Innovative Magnetic topology	27
Feedback pipe network	28
Chapter 6 Experimental evaluation.....	29
Background.....	29
Social findings	29
Measurement techniques.....	29
Comparison with predictions	29

Half scale rig	29
Demo0#3	30
Demo2	31
Experimental results of simulated demo2	32
Electrical rig testing of demo2.....	32
Generalised performance results	33
Chapter 6 Conclusions and Learning	34
Chapter 7 Conclusions and recommendations.....	35
Conclusions	XXXV
Recommendations for future work	XXXV
Appendix 1: Cost Audit	II
Appendix 2: Product Design Requirements	III
Appendix 3: Heat Exchanger convoluted design	V
Appendix 4 Attachments to this Thesis:.....	VI
4.1 Designing a Low-Cost, Electricity Generating Cooking Stove.....	
4.2 Halbach array Linear Alternator for thermo-acoustic engine.....	
4.3 Investigation and Measurement of a Low-cost Loudspeaker	
4.4 Development of thermoacoustic engine operating by waste heat	
4.5 Towards a Transient Simulation of thermo-acoustic Engines	
4.6 Design and development of a low-cost, electricity-generating ... Stove.....	
4.7 Generating electricity in developing countries using thermo-acoustics	
4.8 Investigation of thermo-acoustically Driven Linear Alternator	
4.9 Presentation to the UK Parliamentary committee Dec 2009.....	
4.10 Application of Thermo-acoustic, electrical generating engines	
4.11 Design and Testing of a Wood Burning Electricity Generator... ..	
4.12 Construction and Assessment of a Propane driven ... stove	
4.13 Development of Thermoacoustic Engine	
4.14 Improvement of the Travelling Wave Thermoacoustic Engine	
4.15 Investigation and Measurement of a Low-cost Loudspeaker	
4.16 Low-cost, electricity generating heat engines for rural areas	
4.17 Development and Assessment of a Score ... Engine.....	
4.18 Analysis of the effects of different types of loads	
4.19 Score Project Plan	
4.20 Score CA agreement	
4.21 Score Intellectual Property Agreement	
4.22 Score External Collaborators Agreement. (Template)	
4.23 Patent: heat exchanger arrangement.....	
4.24 Patent: Linear Alternator.	
4.25 Module1: the Score story.....	
4.26 Module2: thermo-acoustic background.....	
4.27 Community web site working practices document.....	
4.28 Demo2 Installation Document.....	

LIST OF FIGURES

<i>Number</i>	<i>Page</i>
Figure 1, View of Hagam village in Nepal	15
Figure 2, preparing food in the village.	15
Figure 3, Riley with mud surround stove	15
Figure 4, preparing to seal the chicken feet.....	15
Figure 5, Women collecting wood.	
Figure 6, Still for making alcohol.	
Figure 7, Utensils in market.....	16
Figure 8, Demo0#1.....	17
Figure 9, Iterative design process used by Score.....	18
Figure 10, system energy flows.	20
Figure 11, Power versus operating frequency for a variety of magnet costs.....	20
Figure 12, functional diagram of a single and $\frac{1}{4}$, $\frac{3}{4}$ wave dual regenerator TAE.....	22
Figure 13, early conceptual design of the dual regenerator Score-Stove™2	22
Figure 14, cross section of the TAE core; heat exchangers and regenerator.....	24
Figure 15, a showing the Demo0#3 radiant HHX, b the final convoluted design.	25
Figure 16, cross section of loudspeaker.....	26
Figure 17, (a) standard Halbach array, (b) double array used as LA. (c) 3D view of (b). ...	27
Figure 18, (a) simulated voltage against time (position) of the coil.	
(b) Measured versus simulated voltage	27
Figure 19, Demo0#3: Cooking, lighting and mobile phone charging	30
Figure 20, measured heat flows in Demo0#3.	31
Figure 21, Demo2 rig test	32
Figure 22, experiment 49 results generating 27.8 Watts of electrical power.	33
Figure 24, characteristic performance curves for Demo2.	34

NOMENCLATURE

Symbol	Description	Unit	Symbol	Description	Unit
A	Area	m ²	Sd	thermo-acoustic duct (pipe) area	m ²
Br	Magnetic field strength	Tesla	T _c	Regenerator temperature ambient side	°K
C	Speed of sound	m/s	t _c	Regenerator temperature ambient side	°C
C'	Mechanical Volume's Equivalent electrical capacitance ⁱ	Farad	T _h	Temperature of the hot side of the regenerator	°K
Demo0#1	Designation for rigs, usually instrumented and used for scientific experiments. Demo0 the ones at Nottingham. The # number is updated with major changes. Demo1 is the one at Queen Mary, Demo2 is the planer design that became Score-Stove™2.		t _h	Temperature of the hot side of the regenerator	°C
Dp	Pipe Diameter	mm	U	Thermoacoustic gas volumetric velocity	m ³ /s
φ	Volume porosity of the mesh (metal volume/total regenerator volume)	%	u	Peak velocity	m/s
h	Heat transfer constant, proportional to temperature includes convective and conductive elements (<i>h_b</i> for the bulge and <i>h_c</i> for convoluted plate)		v	Particle velocity (peak)	m/s
L'	Acoustic Inertance's electrical equivalent	H	Wa	Electrical power from the alternator	W
L _{cu}	Effective length of wire in the magnetic field	m	We	Electrical watts (to distinguish from Watts thermal, W _{th} where there may be ambiguity)	W
Lp	Pipe length	m	W _{max}	Maximum electrical power	W
Pa	Atmospheric pressure	Bar	W _{th}	Thermal watts	W
Pm	Mean pressure in TAE	Bar	Z0	Characteristic duct impedance, rho x density of the thermo-acoustic gas.	Ns/m
Q	Total heat transfer rate from the HHX to the regenerator (<i>Q_b</i> for the bulge and <i>Q_c</i> for convoluted plate)	W	Z0'	Electrical characteristic impedance	Ohms
R'	Equivalent electrical resistance ⁱⁱ	Ohms	σ	Stefan-Boltzmann constant 5.670373 10 ⁻⁸	W/m ² /K ⁴
Re	Effective coil resistance	Ohms	τ	Tau, Regenerator thermal time constant	seconds
RL	Load resistance	Ohms	ω	Frequency	Rads per second
Rp	Pipe loss	Ns/m	ωτ	Regenerator non-dimensional figure of merit [31]	#
Rr	Regenerator loss	Ns/m	ρ	Density of the thermo-acoustic gas at STP	Kg/m3
Sc	Linear Alternator cone area	m ²	ε ^{tag}	Emissivity constant	#
Score-Stove™	The name of the stove implemented in a village. Suffix: 1 = non-generating, 2 = thermo-acoustic generation, 3 = thermo-electric generation.				

ⁱ This is the analogue of a mechanical volume. Note volumes are always connected to ground in the electrical circuit. Series capacitance has no acoustic equivalent.

ⁱⁱ Equivalent to mechanical loss

CHAPTER 1

INTRODUCTION

Basis of this PhD submission.

This PhD is non-standard being by a staff member using publications as described in the University of Nottingham Quality Manual [32], which states that employees engaged in research for over 4 years may submit an extended abstract of papers produced during their time at the University, for assessment by two external examiners under the auspices of an internal advisor.

The PhD describes Riley's involvement in the Score project which is itself innovative and different from other research projects as it was jointly funded by the UK Engineering and Physical Science Council (EPSRC) and international development agency DFID. Selection required both excellent science and impact in the developing countries; therefore innovations in project management, social science and technical aspects are covered.

In each section below, the background describes the work done by the team, and in subsequent paragraphs the work contributed mainly by Riley. An electronic copy of this thesis can be found here: <https://dl.dropboxusercontent.com/u/102255847/papers/PHRthesisfor%20PhDfinalwithjournals.pdf>

Previous research

The report from the World Bank [33] states that "Research on improved cookstoves dates back to the 1950s; the ensuing decades witnessed large-scale field programs centered [sic] on increasing the efficiency of certain stove designs. Over the past 30 years, the focus of the international community has gradually shifted toward the socio-cultural contexts in which the stoves operate. While the stoves themselves may have been simple, their effects on household and regional health and economics have often been complex and far-reaching. In short, many approaches to introducing improved stoves have been tried, with some successes and many failures... From 1980 until about 2002, hundreds or even thousands of artisan-produced cookstove models were developed..." The German development agency GIZ (formally GTZ) funded a large clean stove programme called PROBEC [34] that had limited success in introducing clean cooking stoves in South Africa [35] from 1997 until 2010. Although the Chinese has had wide success introducing 116 million clean cookstoves, the uptake is only 8% for the rest of the world [33].

The backdrop to this lack of progress is the experience of the three billion people who cook on open fires, who experience first-hand the watering eyes and coughing caused by smoke, and also suffer associated premature deaths. The number of people suffering from smoke-related healthy issues has recently been increased, according to surveys discussed in the Lancet Global Burden of Disease Study 2010 (GBD 2010), from 2 to 4 million people per year that die prematurely due to household air pollution [36].

The assertion of the Score project is that the wide scale adoption of clean stoves will occur following a deeper understanding of the social needs, motivators and inhibitors.. Men and women have cooked on open fires for over 70,000 years so any major change will require deep knowledge of the underlying human factors, as well as generating the need for change in the end-users, some of which are now described. The Score project, therefore, has three major elements: clean cooking, the addition of electricity and understanding of the social context.

Hutton [37] discusses the costs and benefits of reducing indoor air pollution and shows that in most rural areas there is an overall economic (as well as health) benefit to reducing smoke through the use of improved cookstoves. Interestingly, although most recent efforts for reducing smoke inhalation have concentrated on smoke produced from wood [38], Obeng discusses the benefits of Photo-Voltaic (PV)

solar lighting on health by reducing smoke from kerosene lamps used for lighting [39]. Gurung [40] discusses rural electrification in Nepal and states “although these technologies are suitable for providing electricity in isolated and remote rural areas, their implementation programs [sic] have not been successful as expected.” He concludes that penetration of mains electricity to rural areas is only 1% of total energy consumption. A more attractive solution is presented by Urmee [41] in an analysis of off-grid renewable energy systems based on a literature review covering Bangladesh and Fiji. Key requirements for success require cognisance of the social, institutional, economic and policy aspects of implementation. This view is supported by work done in India [42] where small-scale power generation systems based on the renewable energy sources are more efficient and cost-effective than providing mains supplies, particularly to remote communities. Early work on providing sustainable energy for development concentrated on providing the lowest cost solution [43]. Other work has shown that the social context is highly influential to large-scale sustainable energy uptake [44]. Mainali discussing Renewable Energy (RE) policy states [45] “The study shows that awareness levels in adopting RE-technologies and willingness of people to access and pay for electricity have increased significantly. However, there is a huge financial gap between the cost of electrification and the affordability. Bridging this gap is a crucial issue that needs to be addressed for the smooth expansion of rural electrification in the country.”

Little work has been done to compare the economics across different stakeholders of different methods of delivering off-grid rural electricity in combination with clean cookstoves, or in analysing how to package products together to improve affordability. Only since the Score project began have there been any publications on clean cooking stoves that generate electricity; a 2010 example is this one at Penn State in the USA that managed 25mW of electrical power [46].

Background and context

Of the three billion people that cook on an open fire, suffering ill-health through smoke inhalation, 1.4 billion do not have access to electricity, most live in rural areas, and many live in poverty. The typical method of cooking used 3 stones arranged in an open circle with wood placed in between two of the stones. These generally have very low thermal efficiency; typically 7%. A recent sub-Saharan Africa survey [47] states “half the population in sub-Saharan Africa will still be without electricity by 2030, and the proportion of the population relying on traditional fuels for household energy needs will remain the highest among all world regions (UN-Energy/Africa, 2011)”. Dr Teo Sanchez of Practical Action, comments [61] that there have been hundreds of clean cook-stove designs. Outside China implementations are measured in the millions, which is less than 8% of what is actually needed. This view is supported by the World Bank and is discussed later [33].

Riley’s involvement in the Score project, which is documented in this PhD thesis, is to investigate methods to promote much larger impact, nearer 50%. As the late President Kennedy said in 1962 [48] (of going to the moon) “..We choose to ... do the other things, not because they are easy, but because they are hard, because that goal will serve to organize and measure the best of our energies and skills.”

The hope is that this work encourages others to find larger-scale solutions, improve rural life and alleviate poverty from many areas; like going to the moon, this is an enormous task.

In May 2006 EPSRC held a one-day workshop to ask for solutions to rural energy provision. Riley pulled together a five organisation consortium, led by The University of Nottingham, with Professor Mark Johnson as the Principal Investigator (PI) and submitted a successful research proposal. The following year the 5 year £2M Score project came at the top of the selectors list and commenced in March 2007. The £230k 12 months Score follow-on project SoFo started in April 2012. Riley was the Project Director for both projects and was responsible for the administrative and technical management. The goal of the work is to outline the technical, social and financial requirements that will enable a clean-burning electrical-generating stove to be implemented in the hundreds of millions. He also led much of the research work which forms the basis of this PhD submission. The original concept for the Score-Stove was a wood or dung burning cooking stove that also generates electricity

by means of thermo-acoustic technology and is targeted at rural communities in developing countries. The Score project comprises technical, social and impact management research. A later development, Score-Stove™2 holds the world record for a wood-powered, electrically-generating, thermo-acoustic cooking stove at 23 We. Riley has also produced the first and currently only simulation in the world that has produced representative transient simulations of the squegging effect of a thermo-acoustic engine [5].

Problem and overview

Project Management

The original Score plan [20] was to undertake 3 years of research from March 2007 until March 2010 and then only the PIs (Principal Investigators) plus Riley would be involved in the last 2 years of dissemination and exploitation. The Score follow-on project SoFo proposal was written mainly by Riley with Prof Johnson the assigned PI, as Riley was not at the time eligible for that role. The 12 month SoFo project started in April 2012. The work done by Riley during these two projects forms the essence of this PhD submission. Riley was remunerated for 50% of his time for the first 4 years of Score with the University of Nottingham and 80% for the remainder, although he worked full time on his assigned projects. He was also involved in Knowledge Transfer Secondments (KTS), Knowledge Transfer Partnership (KTP) and Corporate Social Responsibility (CSR) activities over the six years.

Social

Outside China, the best smoke-free stove project implementations are measured in the low millions, whereas the market requirement is approaching ½ billion. GIZ (formally GTZ) the German development agency) have been active in clean cookstoves for over 20 years [49] with their Southern African initiative PROBEC [50] completing 2 years ago. The then US Secretary of State Hillary Clinton in 2010 announced the Global Alliance for Clean Cookstoves [51] initiative that aims to install clean stoves in 100 million homes by 2020. Our hypothesis is that very large-scale uptake of clean cookstoves will require significant understanding and needs to take cognisance of social requirements. Some people believe that smoke-free stoves will result in termites eating their houses away [52], a stove that cannot accept a still (for making alcohol see figure 6) will not be accepted and without the support of all the key stakeholders large-scale deployment is less likely. 2012 was the year of sustainable energy for all [53], “an initiative launched by the United Nations Secretary-General and guided by his High Level Group that brings all key actors to the table to make sustainable energy for all a reality by 2030”. Our belief is that a cooking stove that has added functionality, such as the ability to provide lighting and charge a mobile phone together with a package that makes it affordable, will provide the social incentive to change the cooking habits of the rural poor that have probably survived for over 70,000 years, to enable very large-scale deployment, something past initiatives have not managed to achieve.

Thermo-acoustics

A number of technologies to meet the electrical generating requirement from a clean cookstove were considered during the Score project [26]. Thermo-acoustics has the advantage of being both low-cost, due to only one moving part, and scalable to higher power levels with the same fuel consumption and was thus the technology chosen.

The phenomenon of heat producing sound was discovered by Byron Higgins in 1777 who demonstrated a spontaneous generation of sound waves in a pipe. A century later Lord Rayleigh [65] explained the phenomenon qualitatively. In the 1970s’ Ceperley [65] postulated an acoustic wave travelling in a resonator could cause the gas to undergo a thermodynamic cycle similar to that in a Stirling engine. In the last decade of the last century, Swift at Los Alamos laboratories in the USA made considerable contributions to thermo-acoustic science by developing a simulation package called DeltaE and its development DeltaEC. The package enabled many thermo-acoustic coolers and engines to be developed. One was a plutonium-powered space probe that generated 100 We and a cooler

producing 400 gallons per day of methane with no moving parts. As of June 2013, the team led by Professor Wai Dai at the Chinese Academy of Science hold the efficiency record for a 1kWe 18% efficiency thermo-acoustic engine (TAE) using pressurised helium. The lowest on-set temperature TAE is held by Aster Thermoakoestische Systemen in The Netherlands of 34K [67]. The Score-Stove™2 held the record for a wood burning TAE as of Dec 2012.

Thermo-acoustics has been used successfully in many cooling applications (TAC) particularly very low temperatures. A large advantage is that TAC's use safe working gasses that do not contribute to global warming. Reference [27] gives an overview of the technology.

Score Research Objectives

The Score submission document stated the following as its research objectives:

1. Contribute to increasing wealth and education and improving health in developing countries by investigating appropriate and affordable novel technology to meet the energy needs of isolated rural communities in developing countries. This technology is designated, SCORE, the Stove for Cooking, Refrigeration and Electricity supply.
2. Develop a Project Network, comprising academics from both the research team and local universities acting as knowledge hubs in the target countries, charities and non-government organisations, government representative and the local communities themselves. Exchange and focus the scientific, technological and social knowledge required by Score. Promote Score worldwide and provide a database of end-user requirements and product applications
3. Plan and create the mechanisms for implementation of Score by identifying barriers to implementation and proposing solutions, forming collaborations within the developing countries, developing training strategy and suitable training materials, encouraging the acquisition of matching funding, promoting the building of local manufacturing capacity, and highlighting the wider business opportunities of Score-Stove in developing countries.
4. Capture and evaluate the underpinning scientific knowledge of thermoacoustic technologies and devise a new engineering concept combining the thermoacoustic engine, electrical generation and refrigeration. Integrate these in a technology demonstrator.
5. Study heat transfer processes in combustion and thermoacoustic systems and devise a high-efficiency, integrated combustor/heat exchanger/stove unit, capable of fulfilling its cooking function and providing the energy to the thermoacoustic element. Evaluate its performance by experimentation and integrate it into a technology demonstrator.
6. Devise through interdisciplinary research an inexpensive method to convert acoustic energy into electricity that could be easily mass-produced and evaluate its performance.
7. Study the manufacturability, cost and the potential of using indigenous materials and local skills and based on the technology demonstrator, to design feasible Score-Stove prototypes, which could be field tested at selected locations. Build and demonstrate the prototypes in selected rural communities.
8. Benchmark the design against other technologies and recommend future development paths, research and applications.

The Score project has addressed all of these research objectives and the work submitted in this thesis has made major contributions to 1, 2 and 3 as described in Chapter 2, and 4, 5, 6 and 7 described in Chapters 3, 4 and 5.

Score Consortium

From discussions held during the 2006 EPSRC workshop, Riley realised that a clean burning and efficient wood burning stove that also generated electricity would be a major contributor to alleviating poverty and improving the health of rural people. He remembered a phenomenon called Thermo-Acoustics (TA) that converted heat into sound without any moving parts. A Linear Alternator (LA) then converts the sounds to electricity. At that time Thermo-Acoustic Engines (TAE) were little more than a laboratory curiosity. The applications thus far had been expensive such as a plutonium-powered 100 We generator for a deep space probe and a plant to liquefy 400 gallons per day of methane, both developed by Swift and Backhaus of Los Alamos Laboratories in the USA. (Interestingly, since 2007 there has been a rapid increase in TAE applications). Riley identified the key research topics as :

- understanding of the social implications
- the thermo-acoustic technology
- a Linear Alternator (to convert sound to electricity)
- combustion
- low-cost manufacturing

From discussions at the workshop with other academics and subsequent web searches he formed a consortium of the best researchers in the UK to meet the above topics plus engaging Backhaus of Los Alamos National Laboratory (LANL) in the USA as a consultant. The responsibilities were as follows: social implications - the Charity Practical Action, TA technology - The University of Manchester, Linear Alternator - the University of Nottingham, Combustion - Queen Mary University of London (QMUL) and low-cost and appropriate manufacture - Imperial College London. Due to principal investigators obtaining promotion to professor, the work at Imperial moved to City University and Manchester to Leicester University.

We believe that this is the first time that clean cooking and electricity generation have been combined in a single product and this innovation was the main reason that the submission to EPSRC was not only successful, but (from informal feedback from EPSRC) was placed head and shoulders above the other entries.

Web site and publicity

Early on, it was realised that considerable amounts of data would be generated during the project and that robust knowledge management would be required. Riley set up these procedures and the Score web site itself [28]. An index of papers was published, updated throughout the project and kept on the web site [54]. Confidentiality of each piece of information was made clear and documented here [29]. Riley was responsible for overall dissemination and publicity and discharged this duty through the web, press releases and the international conference he organised [55]. As a result of controlled press releases, over 75 articles have been written to date, in more than 10 different languages [56] with Riley giving live radio interviews and appeared on Jaipur (India) and BBC television news.

Project Management

Managing such a large consortium is non-trivial, so industrial strength project management techniques were used. Responsibilities were clearly identified and Work Package (WP) owners assigned with defined milestones and deliverables. Overall management was by an Executive Committee chaired by Riley with a PI representing each institution. Professor Mark Johnson from Nottingham was the lead Principal Investigator. Sub-committees were formed as required, for example the technical and intellectual property committee. Executive meetings were held every quarter. Each one was at one of

the institutions appropriate to that stage in the plan [20]. Riley organised all the meetings, agenda and ensured adherence to the plan with actions assigned to WP owners and wrote the minutes. He led the discussions, organised signature of the consortium collaboration agreement [21] and negotiated the terms of the intellectual property agreement (IP) [22]. In collaboration with Nottingham research services, he produced a standard form of collaboration agreement [23] for people external to the consortium and the rules for publishing work.

Early Executive meetings agreed the Score covenant, which is that IP would be given freely to developing countries in exchange for sharing any improvements, which is novel in this context. Licence agreements would be made available to developed countries with a proportion of any money received used to subsidise the developing country work. Pre-emptive Patents were deemed to be required to ensure that no external organisation could prevent Score from distributing IP freely. Two Patents, both raised by Riley were produced [24], [25].

Considerable changes had to be made to the plan due to difficulties in recruiting staff, personal problems which led to Backhaus being unable to travel to the UK hence delaying knowledge transfer, having to change the design from a standing wave to travelling wave device due to difficulties in manufacturing a low-cost Linear Alternator that could cope with highly reactive pressures. Riley managed the required changes in plan so that all but one of the original Score project objectives was met before the Nottingham end-date of April 2012; the project demonstrated more than 20 We from a thermo-acoustic wood burning cooking stove. He held dissemination events attended by the requisite number of people. Leicester University has a delayed end date into 2013 and we expect the last objective of providing cooling information to then be completed.

CHAPTER 2

REQUIREMENTS CAPTURE

Score, an end-user driven research project, started with a preliminary survey of six families in a village called Hagam near Yangalot in Sindhupalchok District north of Kathmandu in Nepal and was undertaken by Riley in 2007 [1]. Figures 1 to 6 show images from that visit: the village itself, preparation of food, Riley showing the approximate pot sizes (his hand span is approximately 250mm) a village elder looking at chicken preparation, women collecting wood, to show that size collected, a pot still used for making alcohol and various cooking pots sold in Kathmandu markets. The results of the survey are incorporated in the product requirements document (see Appendix 2). Practical Action subsequently performed numerous surveys using focus groups and semi-structured interviews to provide updated details and differences between countries. [57], [58]. At a workshop of the Score consortium organised by Riley, the survey results were converted into technical requirements that set targets for the subsequent research. QMUL were responsible for documenting both the technical and social requirements [59] that were slightly more adventurous than the original Score submission to EPSRC. The main change was the generated power which was increased from 20 to 100 We so that laptop computers could be powered from the Score-Stove™. From the surveys a product design document was produced; the main requirements are shown in Appendix 2.



Figure 1, View of Hagam village in Nepal



Figure 2, preparing food in the village.



Figure 3, Riley with mud surround stove



Figure 4, preparing to seal the chicken feet



Figure 5, Women collecting wood.



Figure 6,
Still for making alcohol.



Figure 7
Utensils in market.

This pioneering research has led other people to look more seriously at electrically generating stoves for developing countries, including thermo-acoustic generators by Backhaus and Garrett [60]. In parallel the Bio-lite™ stove was developed that uses thermo-electric modules to convert the heat to electricity.

The requirements document was verified in two ways. Firstly the social requirements were tested with two pilot studies and secondly technical evaluations were carried out by a series of experiments on designs called Demo0. Each main design variant was given a build number; so for example, the standing wave unit is designated Demo0#1.

Social requirements verification

Sanchez, from Practical Action organised a pilot study [61] to obtain feedback from end-users and test the validity of the proposed requirements. Twelve early Score-Stove™1 clean burning stoves, (without electricity generation) were installed in each of Nepal and Kenya. The main conclusions drawn were: 1) Even 10 We can make a significant improvement to the villagers, 2) Everybody used lighting, 3) 80% used it for radio and surprisingly 4) 33% charged mobile phones, 16% of whom also charged neighbours or friends phones.

Technical requirements verification

The original 2007 technical design proposed a standing wave thermo-acoustic engine as it was thought to be a simpler design with a demonstrator “Demo1” for delivery in March 2009. Riley instigated a risk assessment in late 2007 of the project, as any delay to the Demo1 date would jeopardise the whole project. As a result, it was decided to manufacture an early demonstrator called demo0 to obtain early experience of a thermo-acoustic engine.

Figure 8 shows an early standing wave design designated Demo0#1. It is a propane-fuelled device with cooking hob and gave the first indications of what the Score-Stove™2 would look like.

Unfortunately, it suffered from a number of problems. The maximum electrical power generated was a few hundred mW of electricity, the tube and plate heat exchanger only had a life of about 10 hours, and the device would not self start; an amplifier was required to stimulate the acoustics before any power output was obtained.

It used a moving-coil loudspeaker as the Linear Alternator that had mass added to the cone to tune out the highly reactive pressure wave from the standing wave. The demonstrator showed a very high thermal gradient of the order of 200C across the stack due to heat transfer being mainly via radiation at the lower end near the flame, and convective at the top. The unit did not self start and had to be excited with a power amplifier, and when it started produced only around 400mW of electricity. The life of the unit was very short, in the order of 15 hours with failures between the tubes of the hot heat exchanger, and in the alternator suspension.

This learning was put to good use and so a radiant HHX was designed and tested for Demo0#2. The heat exchange worked well, but the acoustics were poor producing only a few milliwatts of power.



Figure 8, Demo0#1.

Demo0#3 was a propane-powered travelling wave half-wavelength dual regenerator unit with the TA designed by deBlok, mechanically designed by Riley and is discussed in later chapters. It produced 16 We and was then used to form the technical requirements of later Demo2 units.

Riley learned that the social requirements had a very large influence on the technical design. Low cost was always known to be an important factor. However, we learned that removal of smoke can also have negative consequences, and that some end-user requirements are not always stated, for example the need to be able to operate illegal alcohol stills. Additionally, unlike normal research projects where the major deliverables are restricted to good quality journal papers, the dual nature to also create impact required much better control of the research process itself. Inclusion of industrial design techniques such as risk management, programme protection by backing more than one approach and turning off activities that would not contribute to the final goal had to be included in the plan.

CHAPTER 3 SYSTEM DESIGN

The dominant requirement was for a low-cost design; a highly iterative design process based on aerospace (considered by the author to be best) practice, was proposed by Riley and accepted by the consortium as shown on Figure 9. The methodology, although well understood in high technology industries, is innovative in an applied research context. Separation of requirements (chapter 2) from what is currently being achieved, and future targets helped the consortium focus on the important goals and manage the project risk as unusually, the consortium had to deliver a product design with the ability to be manufactured at low-cost as well as high-quality research.

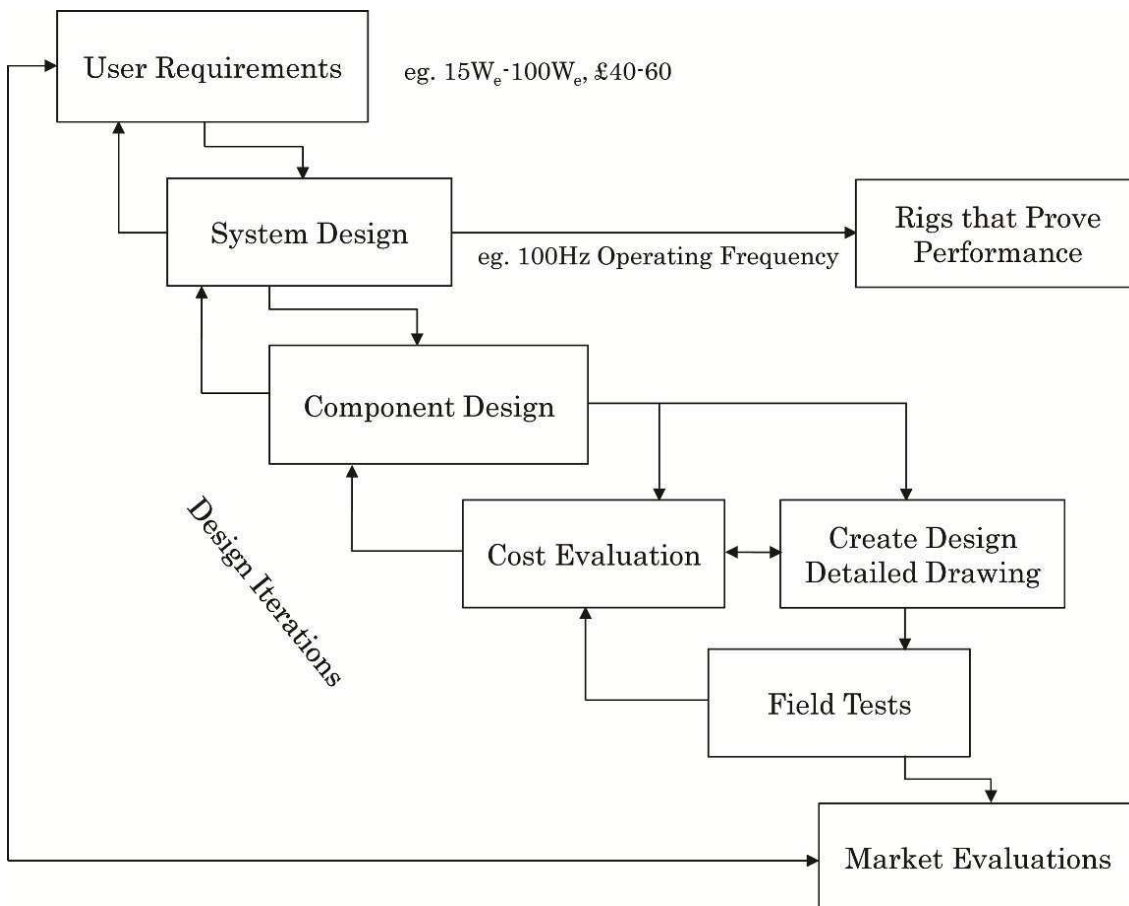

Figure 9, Iterative design process used by Score

Cost comparison evaluation method

Accurate costing figures for units manufactured in high volumes were only available with full detailed drawings. At the system design level this was not possible, and so a method of evaluating the cost of various design options was needed to compare the efficacy of each option. Riley devised an innovative method of breaking down the product cost into various necessary fixed constituents, based on a percentage of product price such as profit, transportation costs and elements that could be affected by the design such as material selection and weight. Labour costs were assumed to be a fixed proportion of material costs based on products of similar complexity. The method is described in reference [1]. It also describes the size of market versus product cost. Later surveys confirmed the target cost of £20 (2007 prices) for 90% coverage and significant market penetration of 60 million people at three times this figure. Since 2007, commodity prices have increased significantly, so to maintain compatibility across designs the 2007 figures of commodity prices and exchange rates (\$2/£, €1.5/£) are used throughout the Score project. Some costs quoted in SoFo documentation have been re-based to 2012 prices. Interestingly, we have learnt that although low-cost is important, affordability is more crucial. The difference is described in reference [7]. In 2011, six engineers from a large blue-chip UK-based

aerospace company audited the predicted high volume cost targets of the Demo2.1 design at £150 in 100,000 quantities (see Appendix 1). This is 50% more than the Score paper which at this stage of the design process is a reasonable agreement. Cost reduction proposals for the most expensive items may halve this figure, bringing the prediction close to the £60 (2007) upper limit of 3 times cost target. Reduction below this level would need further research.

System cost optimisation

Meeting the cost target was and is still the most difficult technical challenge. Considerable research on cost reduction has taken place and is described in this chapter. The potential design space for TAE is very large and can be considered complex; small cost reductions in one area can largely and adversely affect the cost in another. Early in the project Backhaus (a subcontractor to the Score project) proposed a simple Standing Wave (SW) TAE operating at 10 Bar mean pressure using air. The design intent was to make it low-cost due to using air which is free and a SW design which is simpler. However, containment of the high pressure meant that it weighed 100kg and even with low-cost steel, the vessel itself cost more than the target cost figure. A few other TAE configurations were considered [27] with the atmospheric looped tube chosen. A half-scale rig (50mm pipe diameter) was successfully tested by Leicester [62]. Atmospheric pressure was originally chosen as it was thought that sealing a unit above atmospheric pressure when manufactured in the target country would be problematic. However, we learned that acoustic losses increase rapidly as mean pressure is reduced so that any chance of meeting the power requirement would need a pressurised vessel. Our fears were later proved to be true and the issues of sealing units built in country are yet to be solved. A design feedback pipe size of 100mm was originally chosen to meet the power target and was successfully tested in Demo0#3 powered by propane.

However, this design did not meet the power or size constraints and so more design work was undertaken resulting in the Demo2.x set of designs. These used a 75mm pressurised feedback pipe with the prediction of meeting the size and power targets. Work undertaken by Lawn [63] showed a “sweet spot” at 2 bar (absolute) which is well within the pressure limit of the plastic pipes. Numerous minor design changes resulting in Demo2.3 were made to minimise leakage with wide manufacturing tolerances whilst lowering production cost. This version has been chosen for the field trials described in chapter 5.

Material cost

Evaluation in 2007 of a smoke-free stove designed by Alex Zahnd from Kathmandu University in Nepal showed that even with low-cost labour, the stove cost £25 (equivalent UK currency) to make. This excluded any profit or transport, whereas in the UK a stove made in China could be purchased for under £13 that included profit of manufacturer, retailer and transportation costs [11]. Because of the thick metal sections needed for hand welding, the Nepalese stove used a lot of metal, in the order of 30kg. Commodity prices even in developing countries is determined by world markets and so a minimum £/kg has to be paid. The Chinese stove uses thin metal sections with the required strength coming from contoured sections. Additionally in remote rural areas where products have to be hand carried, weight becomes a significant cost. We therefore learned early on that reducing mass was key to cost reduction particularly reduction of transported weight. This innovative insight changed our view of the important route to market of the product and helped to focus attention on which parts to import and those that had to be manufactured locally. In low-labour-cost countries, material costs dominate the product cost so that is where innovation in the design was concentrated.

Energy Flows

The target for wood consumption was to reduce consumption by between 30 and 50% compared with the three stone stove to reduce deforestation. The energy target was then broken down into targets for the other components as shown on Figure 10.

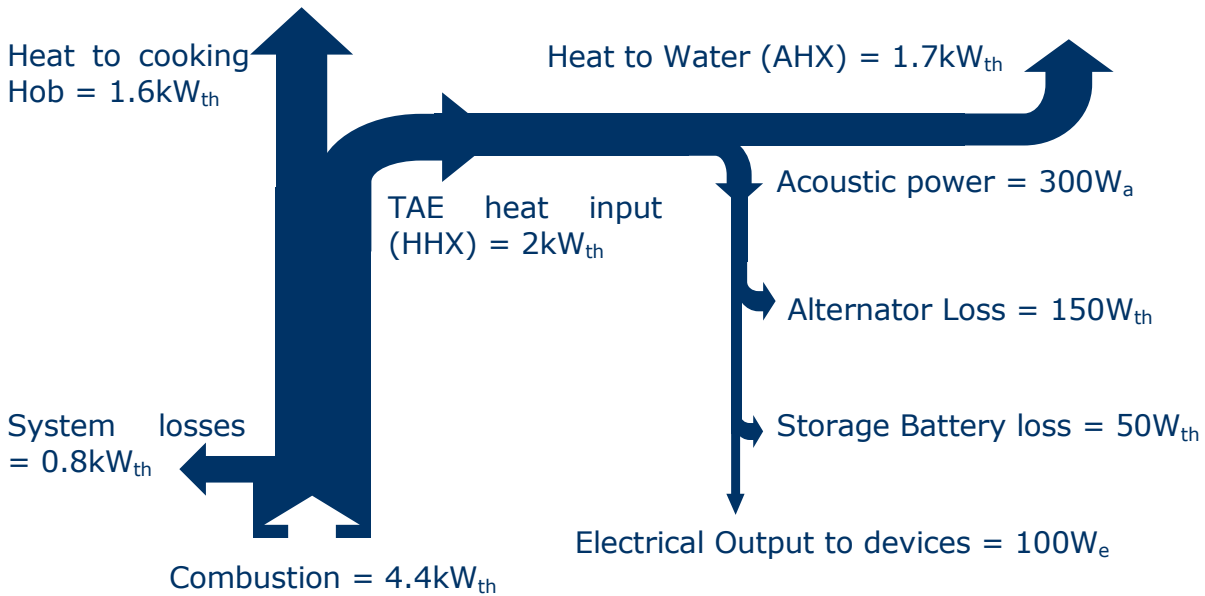

Figure 10, system energy flows.

Linear Alternator cost trade-off

The first system design iteration proposed a unit running at mains frequency, 50 (or 60) Hz so that no power electronics would be required and hence the cost lowered. However, evaluation of the Linear Alternator costs showed that just the cost of the magnet when operating at 50Hz and the required 150 watts [64] electrical output would exceed the total product cost requirement [6]. The design frequency was therefore increased to 100 Hz, being a compromise of cost of the Linear Alternator against thermo-acoustic efficiency. Achieving 100 Hz operation of the TAE loop has proven problematic due to the excess volumes in the heat exchanger assembly that are necessary for easy manufacture. These volumes reduce operating frequency and so a compromise frequency of between 60 and 80 Hz was used; this has meant that the electrical output target had to be reduced to 50 We, the lowest figure that mass manufacturers would accept for a viable product. Dai-Ichi, one of the Score-Community members, provided volume costs for the main magnets. The performance of these is shown on Figure 11 at different frequencies, showing that to achieve the target cost, model A has to be used; meaning a frequency higher than 50 or 60 Hz mains is required.

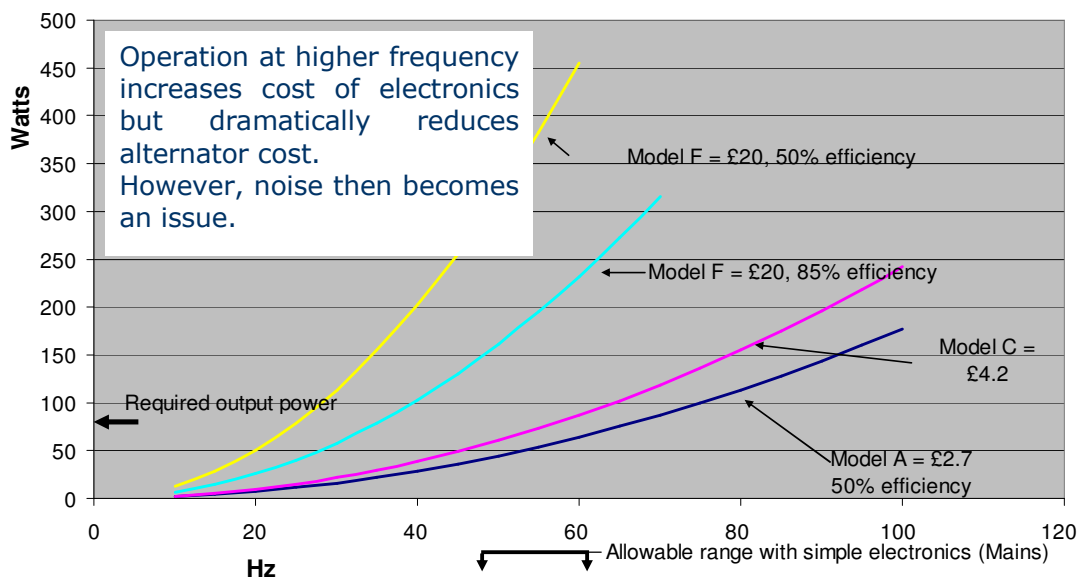

Figure 11, Power versus operating frequency for a variety of magnet costs

Wave type

The two main types of TAE are Standing Wave (SW) and Travelling Wave (TW) [65]. Conventionally the part between HHX and AHX in a SW TAE is called the stack and in a TW TAE a regenerator. A TW device operates the same thermo-dynamic cycle as a Stirling engine with pressure and velocity being in phase through the regenerator. A SW device with a perfect regenerator will not perform [27] because pressure and velocity are out of phase. The SW works only when there is less than 90 degrees between pressure and velocity. This condition is met when imperfect heat exchange between metal and gas exists, hence the term stack rather than regenerator. This imperfect heat transfer causes a delay in heating and cooling of the thermo-acoustic gas introducing a slight phase shift and hence the required less than 90 degree condition needed for operation. Pressure (p) times (in phase) velocity (v) results in real power transfer and a travelling wave, pressure times (90 degree phase) velocity results in imaginary power and a standing wave where power is only stored in the wave and cannot be transmitted. SW TAEs operate typically at over 85 degrees pressure versus velocity; there is therefore a high reactive (out of phase) pressure component. This reactive component is resolved either by a long resonant pipe (like an organ pipe) which is expensive, or by a high mass Linear Alternator (LA). To obtain a resonant high-mass LA requires a large spring. A high-power LA requires a large coil excursion and the combination of a large spring and large excursion is difficult to achieve [9]. From discussions at the Acoustics08 Conference it was decided to move from the SW design to a TW design to simplify the LA design and obtain higher efficiency. This pragmatic decision was later supported by Backhaus in his ASEAN conference paper [66] where his analysis showed that SW devices were possible below 10We but at higher powers TW devices were more effective.

At the start of the Score project, that majority of TAEs were of the single regenerator type. DeBlok was the first to propose multi-regenerator designs and in his Acoustics08 paper [31] described a dual regenerator TAE that had the ability to reduce onset temperature and hence could deliver higher power at lower hot heat exchanger temperatures. His design placed the two regenerators a little longer than twice the peak particle distance apart. Discussions between deBlok and Riley rapidly progressed the understanding of multi-regenerator TAEs; Riley proposed a half wavelength design and a triple design for 3 phase electrical operation, and deBlok used the characteristics of a quarter wavelength to prevent reflections and hence obtain a high travelling wave component even with large changes in area. Many of these innovations are now common place in TAEs for real-world applications.

Number of regenerators

TAEs only operate above a critical temperature between the HHX (t_h) and the AHX (t_c) called the onset temperature. In a TW device, the regenerator acts as a velocity amplifier with low gain proportional to $t_h - t_c$. Onset temperature can be reduced by adding more than one regenerator. The world record of 34K onset temperature held by deBlok [67] was achieved with four regenerators. Work by Lawn on Demo1 [68] and measurements made at City University on wood burning stoves [69] showed that a single regenerator TAE design would be marginal on the low combustion temperatures that can be achieved using wood. A design called Demo2 was therefore designed using twin regenerators, this being a compromise between cost and lower onset temperature.

Dual regenerator design

Although the ideal TW TAE has no standing wave component, practical implementations always have some SW component. The ratio of SW to TW is called the pressure standing wave ratio (PSWR) [27]. $PSWR = 1$ is a pure TW and $PSWR = \text{infinity}$ is a pure SW. Values of $PSWR < 1.8$ are considered good for a TW engine. SW components are caused by reflections where the pipe areas change. One necessary area change is through the regenerator where an increase in area results in lower velocity and hence losses. Lowering PSWR ratios (to reduce losses due to high peak pressures) can be achieved in two ways:

1. By means of tuning stubs
2. By using $\frac{1}{4}$ and $\frac{3}{4}$ wave components that cancel out reflections.

Both methods have been evaluated and are discussed in the experimental chapter.

Figure 12 shows the main elements of the closed-loop thermo-acoustic engines. The left figure (a) is a looped tube full wave single regenerator design with tuning stub. On the right (b) is a diagram of a dual regenerator design that uses $\frac{1}{4}$ and $\frac{3}{4}$ wave pipe lengths for reducing reflections.

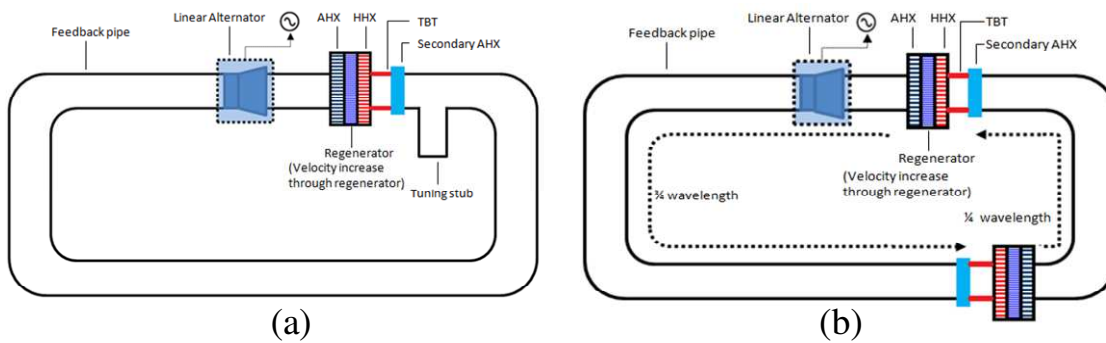

Figure 12, functional diagram of a single and $\frac{1}{4}$, $\frac{3}{4}$ wave dual regenerator TAE

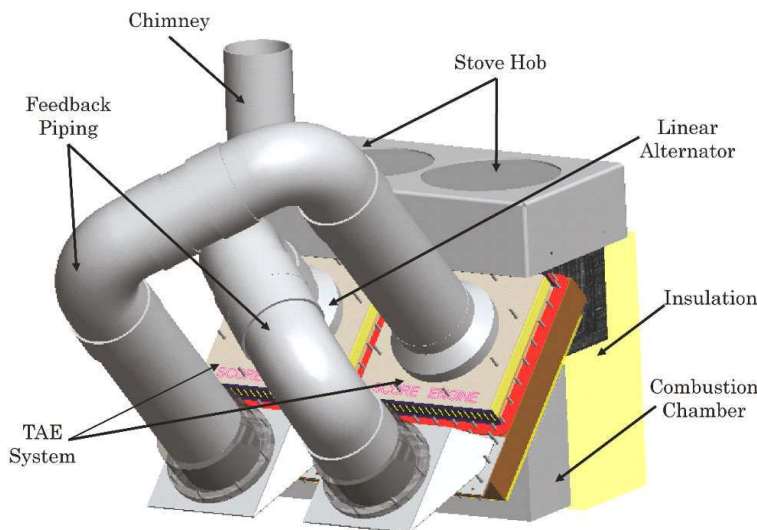

Figure 13, early conceptual design of the dual regenerator Score-Stove™2

Figure 13 an early CAD interpretation of the dual regenerator concept that includes the cooking hob and insulation.

From this chapter, we conclude that the system design and analysis step was very valuable in curtailing areas of research that would not contribute to the stated requirements. In conventional research projects, each concept would have continued until full experimental evaluation was complete. Using these conventional research techniques and with a fixed research resource, would result in the project being unable to produce a product design able to meet the end-user goals. The downside of this method is that slightly fewer journal papers were published. However, in the context of the Score project, this was a reasonable compromise to make.

CHAPTER 4

SYSTEM ANALYSIS AND SIMULATION

Background

Thermo-acoustic engines are notoriously difficult to design; all the individual features have to work near to their optimum efficiency or oscillation will not occur. Mathematical models and full system simulations are therefore essential. The world-leading simulation package is called DeltaEC [70] written by Greg Swift of Los Alamos laboratories in the US, which is freely available for download. Successful TAE simulations have been achieved with commercial packages such as Fluent [71] and many researchers use their own code, often written in Matlab [72]. In the Score project, Jaworski and Yu used DeltaEC, Lawn a Matlab code for simulation and Kees deBlok, CEO of Aster Thermoacoustics, uses his proprietary code. All three predict performance to about 30% (a reasonable degree of accuracy) when the acoustic paths are well defined. However, the need to lower manufacturing costs means that geometry is non-ideal and predicted performance is very optimistic compared with experiment. The combustion characteristics of wood are not easy to predict, being random over time and the analysis tools described above being steady state, mean that predictions of total energy generated were not available. Additionally, experiments at Leicester showed unusual time-based variations in power levels that have not hitherto been predictable.

Laboratory to real product

Riley developed an electrical analogue of a combustion system and a thermo-acoustic engine that used available transient analysis simulations to predict behaviour in what is believed to be the first time this has been achieved. The “fishbone” observation by Yu and Jaworski [73] reminded Riley of the squegging effect sometimes seen in radio frequency oscillators and indeed, the analogue did reproduce such behaviour. The initial findings are contained in this paper [5] which simulated pressure with voltage and particle velocity with current. Volumes can then be simulated with electrical capacitance, and alternator mass with inductance. An undergraduate with much help from Riley used the method to compare predictions with an experiment on a single regenerator TAE with some success. Analysis on a dual regenerator design has yet to predict performance adequately as the system exhibits considerable squegging, resolution of which is an area for future research.

Conclusions

The system design from chapter 3 concentrated on meeting performance targets at the lowest cost. Thermo-acoustic engines are notoriously difficult to design, with 5 main features that have to perform near optimum performance for the total engine to operate at all. The features being: feed back pipe loss, heat exchangers, regenerator mesh, frequency of operation and alternator matching. Without the systems analysis, and simulation tools, it is almost impossible to effect a working TAE. Even with the tools, in order to optimise system performance, many cycles of experimental verification and simulation model tweaks are required. Having optimised performance in an ideal rig setting, conversion of a design into a manufacturable product introduces more non-optimal features that degrade performance. The physics of performance prediction in easy-to-manufacture thermo-acoustic engines is not well understood and a rich area of future research.

Riley has made a major contribution to transient, time-domain based TAE simulation with his electrical analogue [5] that has the ability to predict the “fishbone like” instability discovered by Yu and Jaworski.

CHAPTER 5

COMPONENT DESIGN

Background

Having optimised at the system level, each component then needed to be optimised for both performance and cost. The team identified the following components that were high cost items requiring cost reduction.

1. The hob unit and carcass
2. Heat exchangers
3. Linear Alternator
4. Regenerator
5. Feedback pipe network

Riley made a major contribution to 2, 3 and 5 described below.

Heat exchangers

Other than work by deBlok [74], the methane liquefier by Los Alamos [75] and Score, most TAE heat exchanger designs are for scientific rig operation, most heated by electricity. This has the advantage of being able to accurately measure heat input to the TAE and allows for optimal acoustic design as the heat source is compact which makes it easy to design structures to transfer the heat to the working thermo-acoustic gas. Such solid to gas exchangers are one of a number of classes of heat exchangers liquid to gas, gas to gas and multi-phase being the rest. For each class there are numerous physical implementations which are well documented [76]. The Score application has to operate under real-world conditions over long timescales with a low-cost product. Design of heat flow paths therefore need special attention.

As power output and efficiency is determined by the difference in temperature between the hot and cold side of the regenerator, any decrease in temperature due to inefficient heat exchange will degrade performance. Thermal mass when applied to the ambient exchanger is an advantage, as it delays warming, whereas thermal mass in the hot exchanger degrades performance due to the delay in reaching operating temperature. Figure 14 is a CAD section of the TAE core components.

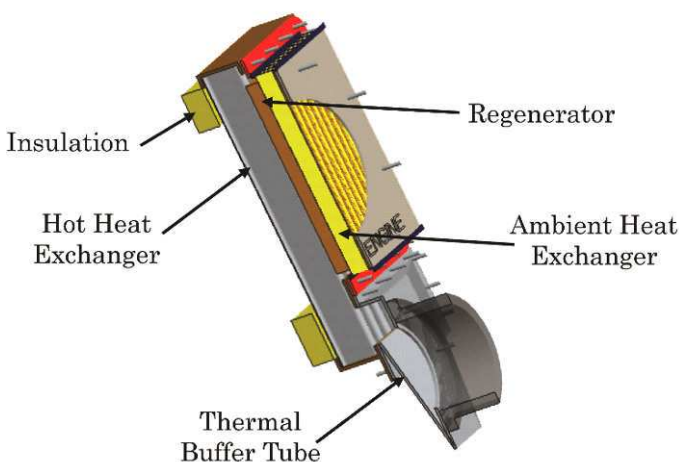

Figure 14, cross section of the TAE core; heat exchangers and regenerator.

Ambient heat exchanger(AHX)

Thermo-acoustic devices can be configured as either coolers or engines. Convention is to call the higher temperature heat exchanger in a cooler and the lower temperature heat exchanger in an engine the Ambient Heat Exchanger (AHX). The term cold heat exchanger is therefore only used in a cooler to prevent ambiguity. The system design showed a requirement to dissipate 1.7kW of heat through the AHX. Inspection of the performance of commercially available solid-to-air heat exchangers showed that a large surface area on the air side was required to dissipate this amount of heat. Performance could be enhanced with fans, but this was rejected on the grounds of cost. Furthermore, to transfer the heat to the large gas surfaces required thick metal sections. Even with the optimum metal, aluminium, the target cost could not be met with this solution. Liquid-to-gas heat exchangers have the advantage that the liquid transfer medium can be water, which is low-cost. The disadvantage is that two exchangers are needed. However, the automotive industry has over 100 years experience in designing efficient and low-cost heat exchangers for engine cooling, so conventional automotive radiators were used for the AHX; predicted costs in volume were slightly higher than the target and this was accepted in the absence of a better solution.

Hot Heat Exchanger (HHX)

The Score project required innovative HHX design to keep the cost low especially as the heat source was burning fuel. This meant that combustion gas to thermo-acoustic gas heat exchange had to take place, with the combustion side being particularly vicious as wood produces many corrosive compounds in the gas stream. Heat pipes were considered for this application, but were rejected due to their limited temperature range. In order to achieve the target warm-up time of 5 minutes (Appendix 2), the Hot Heat Exchanger (HHX) has to be of low thermal mass. It also has to transmit large amounts of heat to the regenerator in a restricted space and from a low energy density heat source such as burning wood. These and the low-cost target restrictions place difficult constraints on the HHX design. The early designs of Demo0#3 and Demo1 used a simple radiant heat exchanger with radiation being directly applied to the end of the regenerator [6] and is a low-cost and simple design. However, thermal power is proportional to T^4 and although adequate heat flow can be obtained with fossil fuel heat sources, experiments at City University [69] showed that obtaining these temperatures with wood would require close control of combustion characteristics that may have been difficult to achieve with manufacturing processes in the target communities. Riley designed a low-mass convoluted HHX that meets the constraints, Chen provided the CADs model and the design is documented in this reference [6] and chapter 6. The same reference also discusses how to lower production costs for other components. Figure 15 shows the two main designs of HHX that were considered.

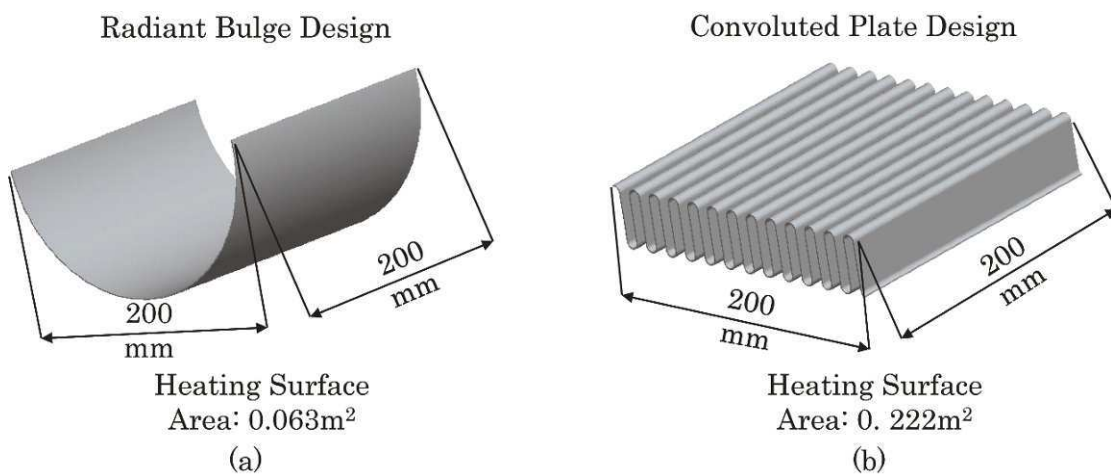

Figure 15, a showing the Demo0#3 radiant HHX, b the final convoluted design.

Linear Alternator performance optimisation

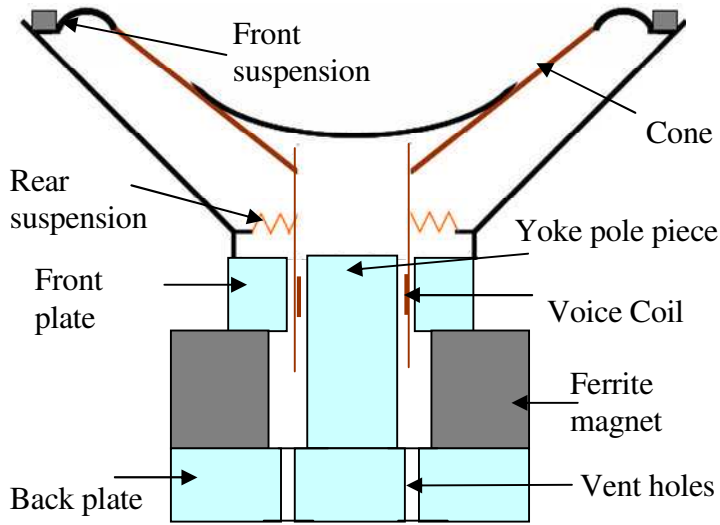

Figure 16, cross section of loudspeaker.

of the suspension [2] and magnet length. A high δ at a given frequency means a high coil velocity, u . With conventional “C” shaped magnets, a high coil velocity causes large gas volumes to be displaced due to the piston effect and in turn this produces losses at the coil exit hole. Increasing the hole size reduces the magnetic strength, further increasing losses. The solution is to change the magnetic topology so that hole size can be increased without affecting magnetic strength. One such configuration is a double Halbach array [77] which has the added advantage of increasing magnetic strength in the coil cavity by $\sqrt{2}$ times at the expense of producing a non-sinusoidal waveform. As the output voltage has to be conditioned anyway with electronic components for mains frequency operation, this is not a limitation. This innovative structure was Patented [25] by Riley and the coil structure optimisation is described in reference [2] and later in this chapter.

Matching LA with the acoustics

The acoustic power to the LA is defined in reference [78] as

$$W_a = \frac{1}{2}[p][U]\cos\theta = \frac{U^2}{2S^2}\left[R_m + \frac{(B_r l_{cu})^2}{R_c + R_L}\right] \quad (1)$$

where S is the cone effective area of the alternator, p is the pressure drop to the alternator, U is the volumetric velocity, $B_r l_{cu}$ is the force factor of the alternator, R_m is the mechanical resistance of the suspension, R_c is the coil resistance, R_L is the load and θ is the angle between pressure (p) and volumetric flow (U).

If the alternator voice-coil displacement is limited to y due to suspension constraints then the maximum output power would be;

$$W_{\max} = \frac{(\omega y B_r l_{cu})^2}{8R_c}, \text{ when } R_L = R_c. \quad (2)$$

Where $u = \omega y$ is the peak velocity of the cone along the Y axis.

Conventional moving coil Linear Alternators (LA) such as a loudspeaker working in reverse, use a “C” shaped magnet [2]. The magnet size is determined by its target cost and is thus fixed. For a fixed magnet size $\frac{(BL)^2}{R_e}$ is also fixed, Peak_voltage = BLu and $u = 2\pi f\delta$ where δ is the maximum excursion of the coil. The maximum operating frequency is determined by the thermo-acoustics, so the only available variable that can increase performance is δ and this is a function

Innovative Magnetic topology

Figure 17 (a) shows a standard Halbach array configuration, and in (b) and (c) the double array used to improve the efficiency of the Linear Alternator from the 35-45% of a standard loudspeaker to over 60%. Additionally, the central hole can be made much larger without affecting the magnetic path, which reduces aero-losses due to the coil displacing air at high velocity.

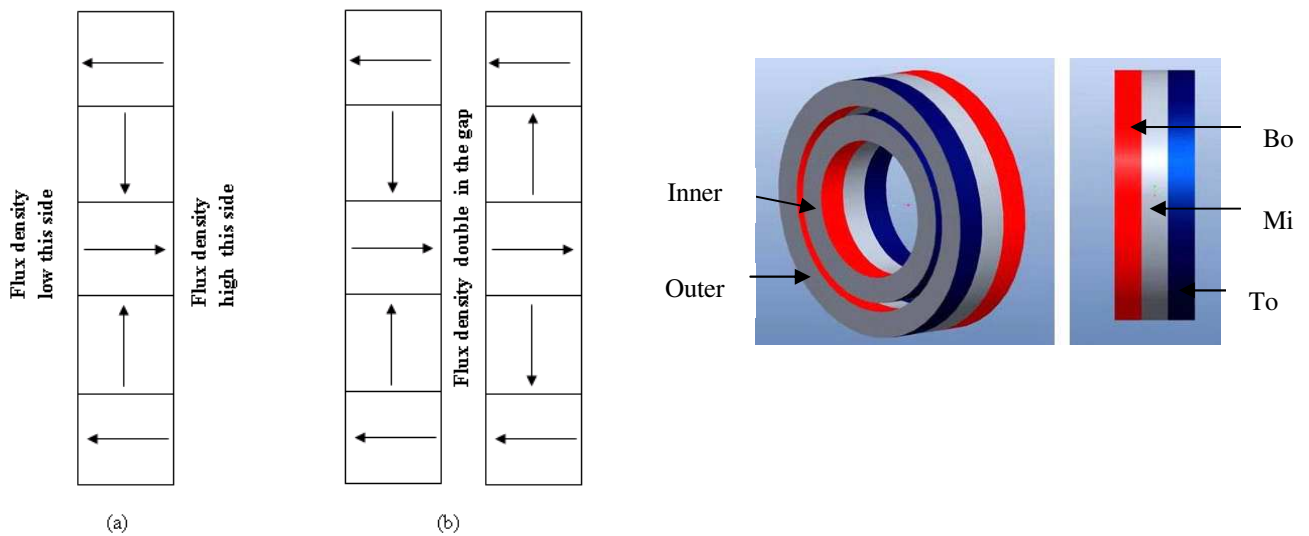

Figure 17, (a) standard Halbach array, (b) double array used as LA. (c) 3D

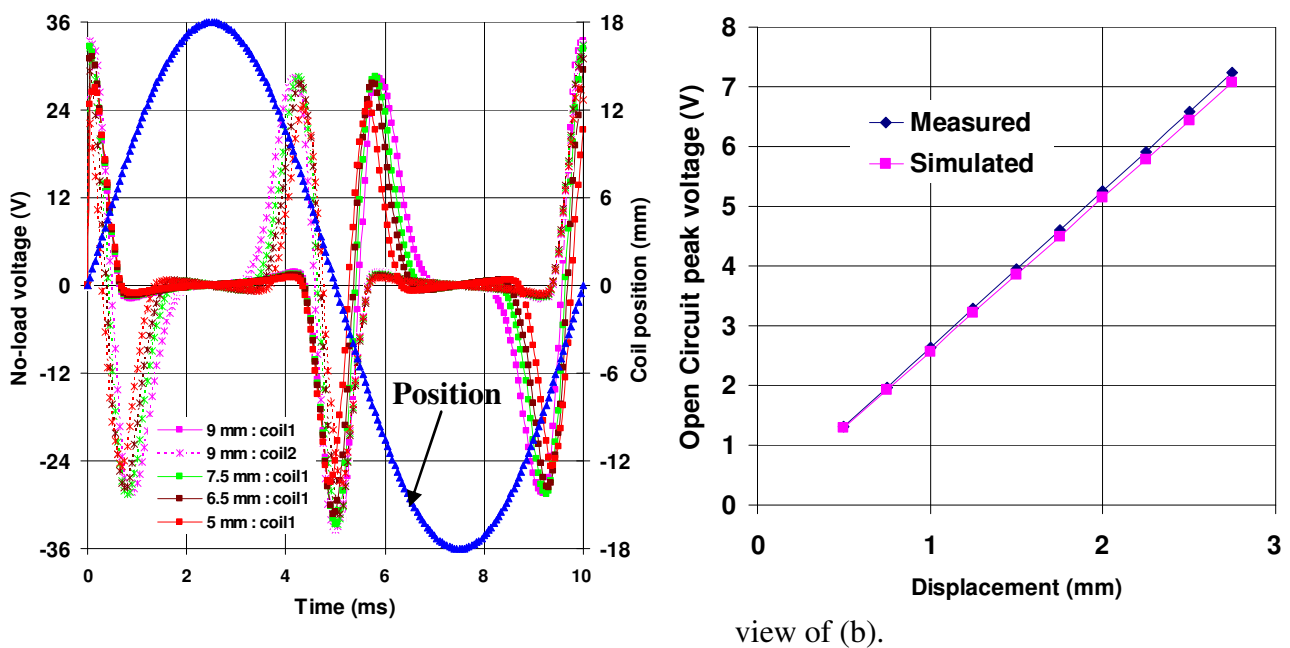

Figure 18, (a) simulated voltage against time (position) of the coil. (b) Measured versus simulated voltage

The Halbach array has the effect of reversing the magnetic field for each stroke of the coil which produces the unusual waveform of Figure 18 (a) for a variety of coil lengths. Each coil configuration was simulated [2] and an optimum configuration chosen. There was good correlation between the simulation and the low amplitude displacement as shown on (b).

Feedback pipe network

Early work focussed on a high pressure TAE design at around 10 Bar, containment of the pressure being a major cost item requiring thick material sections. Riley invented a method of using thin metal sections to both contain the pressure and form internal acoustic paths. Use of super plastic deformation, with diffusion bonding means that complex internal structures can be fabricated in a single manufacturing process and is described in this Patent [24]. It was not pursued within the Score project as insufficient research funding was available. This method has many potential benefits in higher output higher efficiency TAE engines and could form the basis of future research work.

Rig and early development work required an easy method of configuring the feedback pipes, as the simulation tools were not accurate enough to predict exact lengths. Plastic pipes are therefore used in Demo2 systems being available and easy to change lengths and topologies. Pipes are available in different pressure ratings up to 16 Bar and so are suitable for the TAE application during the early experimental and field trial work. However, they do not meet the cost target and so an alternative large-scale volume solution is required. Riley proposed a second cost-reduction method [6] for the feedback pipe by using very thin plastic section, encased in aerated concrete to provide the pressure containment. The realisation of this design also requires development.

A moving coil and hence lightweight, low-cost linear alternator that utilises a double Halbach magnetic array to minimise aerodynamic and acoustic losses is novel and a patent applied for. The main learning here is that a simple dual-coil structure performs within 3% of the best multi-coil system that was simulated. Simplicity and hence cost, prefers the dual coil design.

CHAPTER 6

EXPERIMENTAL EVALUATION

Background

A variety of experiments were devised to test each aspect of the stove design. Practical Action (PA) was responsible for the social science experiments. Conversion of these to technical requirements was led by Riley, with support from PA and City University and documented by Queen Mary University of London. Demo0#3 and Demo2 performance evaluation work was led by Riley with the support of Dr Chitta Saha (Research Assistant) and Mr Chris Cook (Technician) and Linear Alternator performance measurements were led by Riley with assistance of Dr Saha. Some subcontracted measurements were done by Aster.

Social findings

The original plan called for field trials in year two. However due to difficulties in making the TAE perform adequately, Riley organised a re-plan of the project. Field trials in Kenya and Nepal were undertaken by PA using the City University design of a low-smoke stove, with PV cells providing either 10 or 20 We to evaluate user acceptance [1]. The findings of the field trials were fed into the affordability work [7].

Measurement techniques

Measuring performance and then obtaining accurate information to diagnose the reasons for sub-optimal performance of a TAE is non-trivial. Accurate measurement of the phase between pressure signals in a noisy environment has to be performed and electrical power from non-sinusoidal Linear Alternator voltage and current are required. Riley designed both a load simulator and specified National Instruments code that was used to produce Score measurement software used by the team document in references [30]. Riley also taught members of the Score Centres in City University, Malaysia, Bangladesh and Nepal the measurement techniques.

Comparison with predictions

Half scale rig.

Extracts from the product design specification shown on Appendix 2 were used to produce a half-linear- scale, single regenerator, looped-tube TAE rig at Manchester University which they tested. The results below are from reference [62].

Table 1, Comparison of half-scale rig with requirements and simulation

			Required (1/4 power scale)	Input to simulation (DeltaEC)	Measured
Global Parameters	Mean pressure	Bar	1	1	1
	Optimum frequency	Hz	100	72	70
Heater	Thermal heat input	Watts	500	590	703
AHX	Water temperature	K	333	300	300
Alternator	Load Resistor (max power)	Ohms	Not specified	15.6	15.6
	Electrical power output	Watts	25	15.8	11.6

Table 2, half-scale rig key parameters

		Fixed parameters	
Global Parameters	TA Gas	Air	
	Duct size (I/D)	51	mm
	Drive ratio	4.8%	%
Heater	Porosity	10.0%	%
	Hydraulic radius	175	µm
Regenerator	length	21	mm
	Porosity	73.3%	%
AHX	Porosity	70.0%	%
	Equivalent length	6.25	mm

The DeltaEC simulation showed that the required ¼ power output of 25 We (power is proportional to duct diameter²) could be achieved with 933 Wth. However, this condition could not be achieved in the test rig due to the Linear Alternator maximum displacement limit so testing was done at lower input powers. With an ideal rig, it can be seen that power output is 73% of the DeltaEC prediction.

Demo0#3

Demo0#3 is a full-scale demonstrator, powered by propane, with the single bulge radiant HHX. It achieved a maximum output power of 15We.

Figure 19 shows the physical arrangement and Table 3 the regenerator parameters. A summary of results is presented in Figure 20 with full results contained in reference [79].

Table 3 Demo0#3
Regenerator Mesh Data

Wire diameter	90	µm
Wire spacing	250	µm
Volumetric Porosity : φ	79.2%	
Hydraulic radius	86	µm
Regenerator width	170	µm
Regenerator height	170	mm
Regenerator thickness	10	mm
Regenerator hot end	470	°C
Regenerator cold end temperature	26	°C



Figure 19, Demo0#3:
Cooking, lighting and mobile phone charging

Demo0#3 was the first travelling wave experiment to simulate the performance of the complete system and to allow comparison of theoretical heat flows with measured flows. It was apparent that the original heat flow design of Figure 10 was too optimistic. Less heat is available for cooking and the TAE requires more thermal energy than the original prediction as shown on Figure 20. Results from City University showed that the temperature of burning wood varied considerably with time and whilst the peak temperatures could match the propane ones, the average ones were much lower. The radiant bulge is very susceptible to reduced temperatures as the thermal energy is almost all by radiation, which has a temperature⁴ term; so a small reduction in combustion temperature causes a large reduction in heat flow. Riley re-planned the investigations in order to improve the situation: firstly to gain an understanding of why thermo-acoustic performance was low, secondly to improve heat losses and thirdly to increase HHX size so more heat flow was due to convection, thus removing the fourth power temperature dependency. These improvements were incorporated into Demo2.

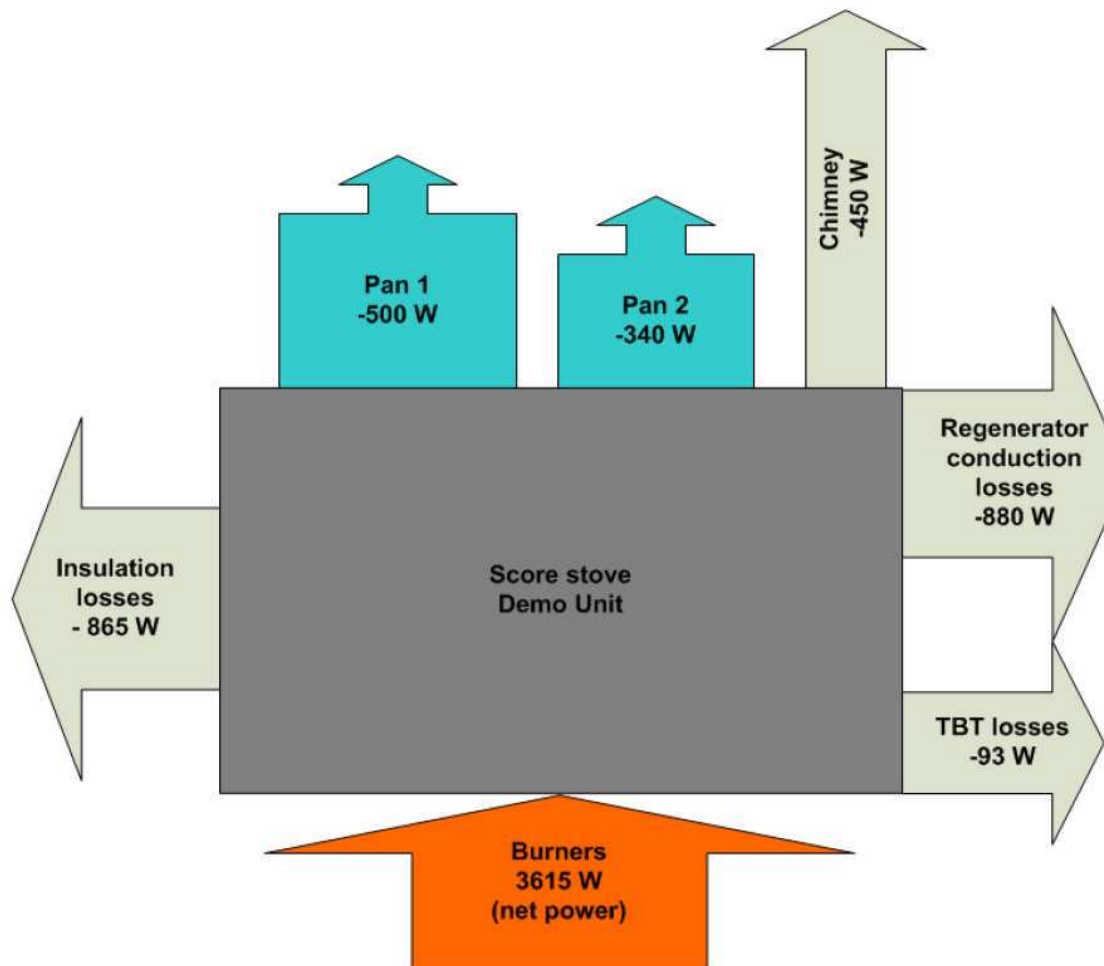

Figure 20, measured heat flows in Demo0#3.

Demo2

Demo2 included the following changes from Demo0#3. More detail is contained in [6].

1. Increased area HHX
2. Lowering of the 2nd AHX to prevent convection currents circulating through the feedback pipe
3. Separation of the two sides of the TAE to make gas sealing easier.
4. Improved insulation to reduce parasitic heat loss.
5. Smaller diameter feedback pipes to make it easier to fold them into a smaller volume
6. Above ambient pressure operation.

Riley re-designed the HHX to preserve the required heat flow but at lower combustion temperatures (Appendix 3).

The original requirement of using atmospheric pressure was because the opinion of Practical Action and City University suggested sealing may be problematical in the field. This prediction has proven correct, but performance was below target so we had to make a compromise. Pressures up to 5 Bar A are easy to achieve with simple tyre compressors or even foot pumps. Additionally, inspection of the TAE performance shows that acoustic loop power increases with mean pressure (at a fixed drive ratio) and acoustic impedance drops [65]. This results in increased dynamic pressure but constant particle velocity. The losses due to particle velocity are constant, but power increases, hence increasing mean

pressure increases efficiency until other losses start to become significant. This insight was described experimentally by deBlok in unpublished correspondence with Riley.

Experimental results of simulated demo2

Before the full demo2 was manufactured, Aster built a simulation of demo2 using aluminium heat sinks that was tested on the City wood burning rig at 1.3 BarA mean pressure. Results were encouraging with 23We being generated for a few seconds until the rig melted [80], [81]. This encouraging result triggered manufacture of the full Demo2 concept.

Electrical rig testing of demo2

In order to make more accurate heat measurements, an electrical heater rig was made to simulate wood combustion so that input temperature to Demo2 could be controlled and the heat applied in a manner as close to wood burning as possible. The only limitation is that the rig cannot profile temperature; the wood burning stove produces hotter temperatures at the bottom of the regenerator compared with the top. The best result achieved was experiment 46 where 37 We were generated at 1.5 Bar Absolute mean pressure, see Figure 21.

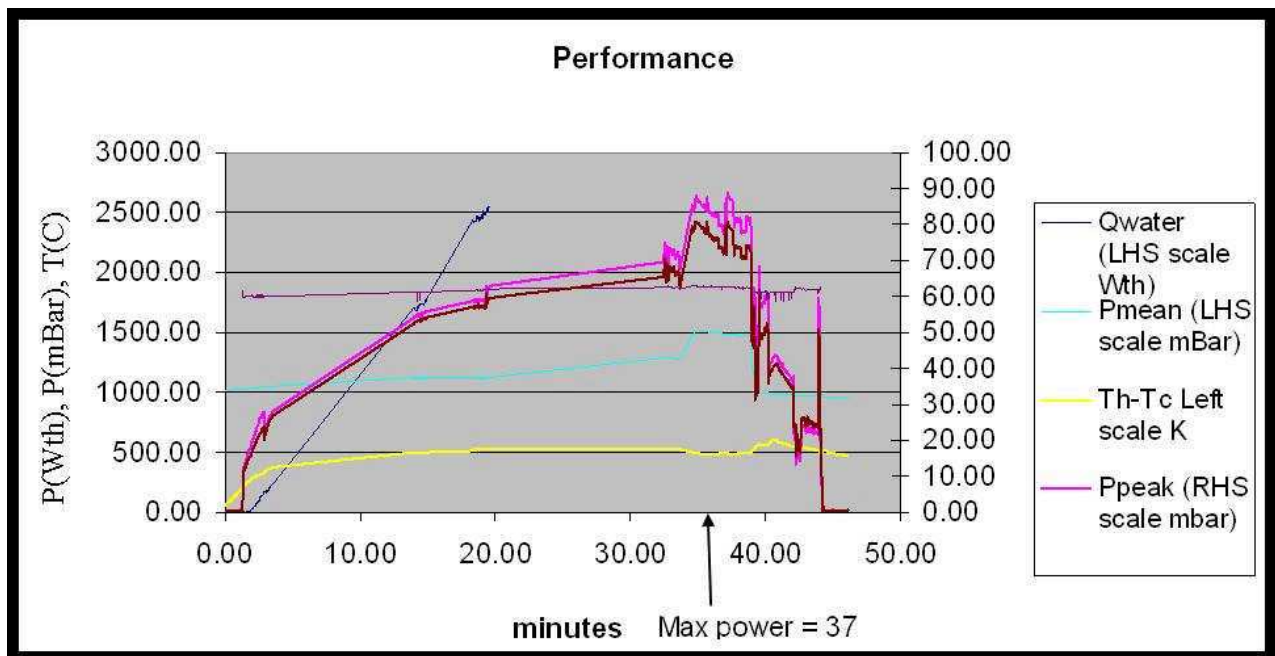

Figure 21, Demo2 rig test that achieved the best electrical output at 14 June 2013 of 37 Watts.

The experiment was repeated a few weeks later with a second build of unit and the same pipe and alternator configuration in experiment 49. The maximum power generated was 27.8 We at 1.8 BarA, as shown on Figure 22. Numerous other experiments have been undertaken to understand why the two results are so different, but the power of experiment 46 has not been repeated. We have investigated the following possibilities in a total of 78 experiments, but have not found an explanation:

Input temperature versus time profile differences, pipe configuration, regenerator configuration, alternator performance, parasitic heat flow changes and main geometrical features.

The only explanation we have is that there is a small detail in the assembly of the TAE core that is significant to performance, but which we have not noticed, or understood its significance. This is another rich area for future research.

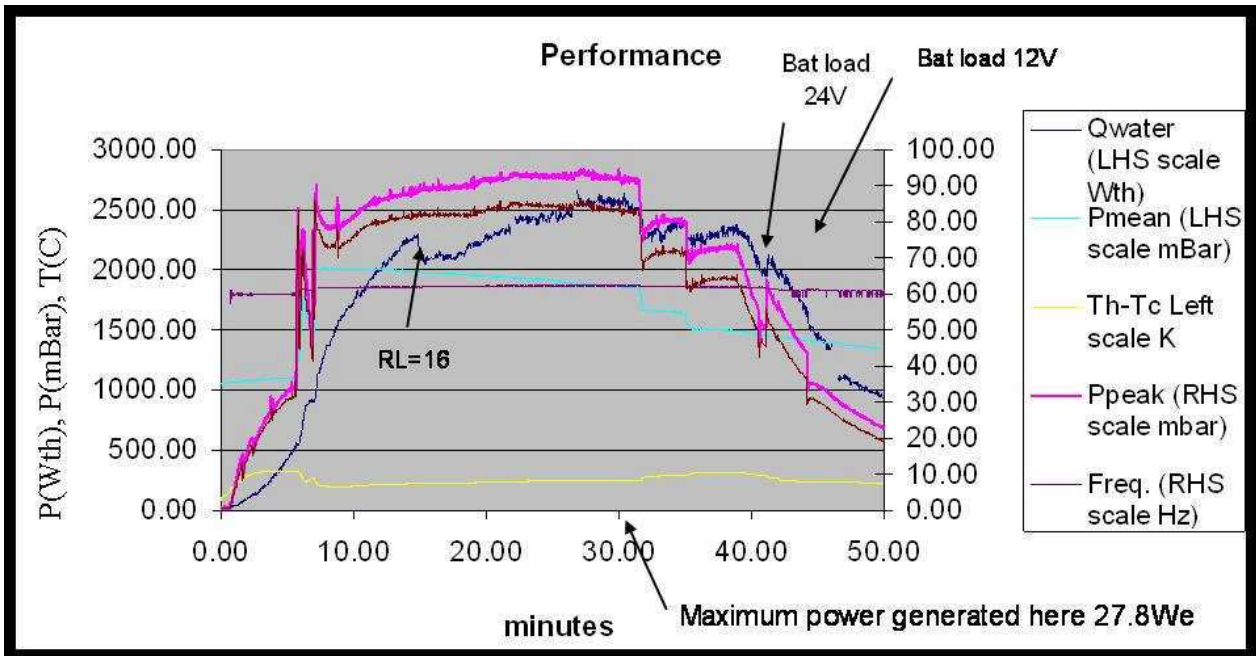

Figure 22, experiment 49 results generating 27.8 Watts of electrical power.

Generalised performance results

A good method of comparing performance across TAEs is to plot $T_h - T_c$ versus either pressure or power output [27]. Power measurement is preferred as it is more accurate and the power can be electrical or circulating acoustic power. As acoustic power is only transmitted in the travelling wave, one has to ensure that if pressure is plotted, either there should be a low standing wave component in the pressure measurement, or only travelling wave pressures are used. These can be derived using de-composition methods [82].

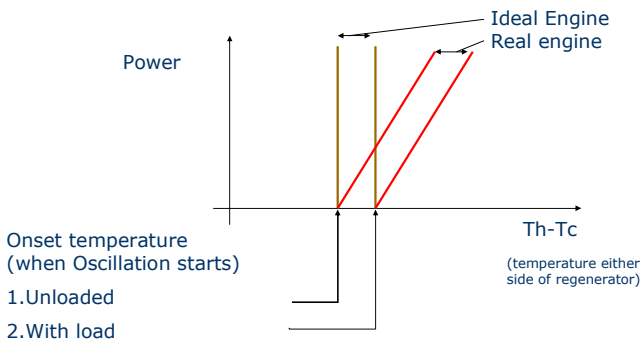

Figure 23, performance measuring curve for a TAE

Figure 23 shows the idealised case. The onset temperature is a measure of how well the acoustic pathways are matched; a lower temperature is better. If a load is applied, for example with a Linear Alternator, onset temperature increases. In a perfect engine (no non-linear acoustic losses) $t_h - t_c$ does not increase with applied heat, power output is proportional to heat input. Real losses cause the slope shown on the figure.

Power output is a function of: mean pressure, drive ratio, $t_h - t_c$ and inside feedback pipe area. Frequency of operation is a function of feedback pipe length and parasitic volumes. Figure 22 shows some typical curves taken from Demo2 experiments for two different mean pressures.

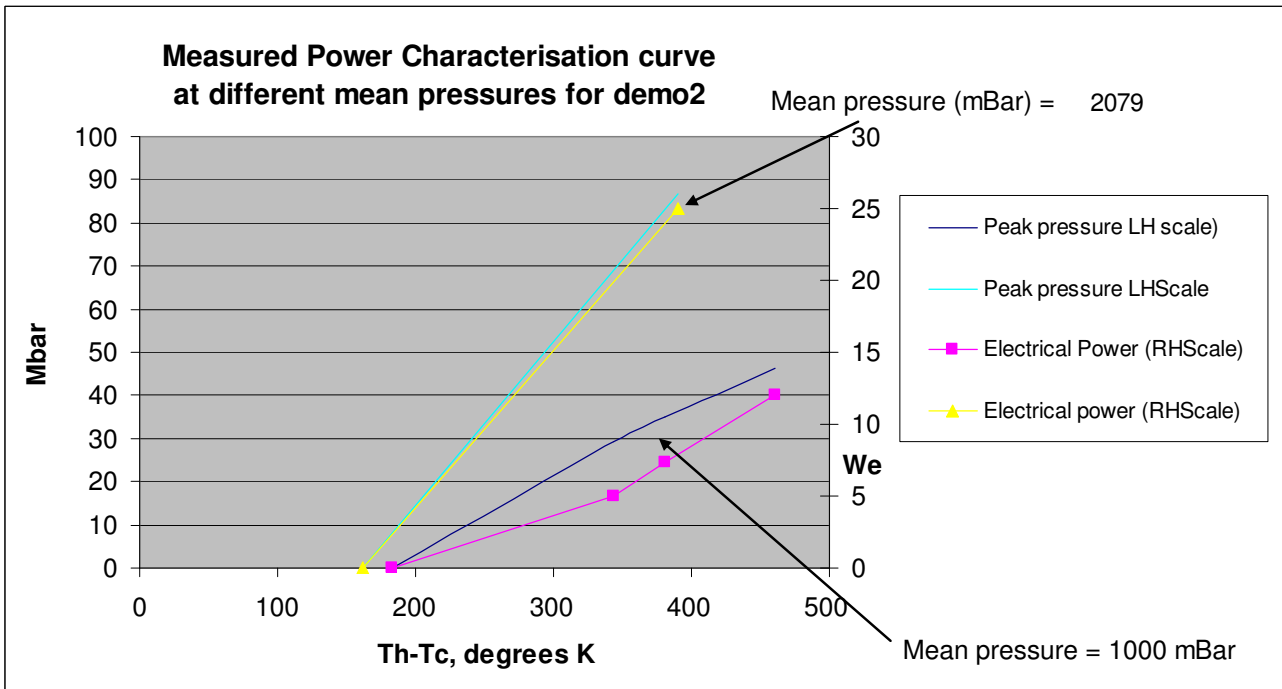

Figure 24, characteristic performance curves for Demo2.

Only two plots are shown for the high pressure 2 Bar case, due to instrumentation error and difficulty stabilising conditions. A straight line is shown so that cases in between the temperature values for later rig tests (particularly the Score Centres) can be compared.

Chapter 6 Conclusions and Learning

The village surveys and more recent evaluation of mobile phone uptake in developing countries demonstrate the absolute need to understand the social elements. Without this understanding it is unlikely that clean cookstoves will have a large uptake. Addition of electricity with clean cooking is highly incentivising to all members of the household and when implemented would be a major breakthrough to improvement in health as it removes the smoke from cooking and kerosene lamps used for lighting and education from better lighting and access to global knowledge through radio and phones.

Ambient pressure TAE's do not perform as well as the simulations, rig results are 30% below prediction and units destined for production have large variations in performance over 32% in some cases and always lower than predictions. The results once again re-enforce the need for more research to better understand the physics behind features needed for real-world TAE products. Sharp bends, steps and surface finish of the internal thermo-acoustic duct are rich areas for investigation.

Even mildly pressurised units (2 BarA) have significant performance improvement on onset temperature and have a steeper power versus $T_h - T_c$ curve, meaning that performance can be preserved at the lower temperatures of burning wood.

CHAPTER 7

CONCLUSIONS AND RECOMMENDATIONS

Conclusions

Taking a new concept such as thermo-acoustics to large-scale implementation has proved to be a complex and challenging endeavour. An understanding of the social requirements, their impact on the technical specification and the acceptance by businesses needed to continue the work, is the most important aspect of the work.

All the original technical research objectives described in Chapter 1 have been met; more than 20We on a wood burning cooking stove have been achieved, a low-cost volume manufactured Score-Stove™ would contribute to health and wealth, a project network is developed with centres in Malaysia, Kenya, Nepal and Bangladesh all undertaking research. Barriers to implementation and their solutions have been proposed. The underpinning thermo-acoustic knowledge and new design concepts are realised including novel hot TAE heat exchangers that also allow adequate cooking and a novel linear alternator design has been realised.

- 1) Although great strides in simulating TAE performance have been made by Swift with DeltaEC, and by deBlok, prediction of performance outside the rig environment has proven to be optimistic particularly with ambient pressure engines.
- 2) With the current UK manufacturing process, variations between engine builds has been measured at over 32%. It is likely that manufacturing in developing countries will make this situation worse.
- 3) With current wood combustion technology, performance is further degraded by a measured 22%, down to 23 We.
- 4) At the lower output of 23We, the view of people with access to the villagers is that this is still a useful device, as long as wood consumption is below current usage.
- 5) The predicted volume cost of £150 is affordable by significant numbers of rural people, but considerable investment in tooling and manufacturing plant is required to make this a reality.
- 6) Reduction down to £60 may be achieved with more research into cost reduction of the regenerator, hot heat exchanger, feedback pipe arrangement and Linear Alternator.
- 7) It is unlikely that the £20 cost target can be met without significant breakthroughs in simulation of system performance and better understanding of the physics behind losses.

Recommendations for future work

- Investigating low-cost carcass manufacture using, for example, foamed concrete with polymer lining.
- Continuing to transfer the technology to developing country universities for local adaptation.
- Investigating the loss mechanisms in features necessary for an easy-to-manufacture product.
- Improving simulation tools to reduce the skills needed to design a thermo-acoustic engine.
- Incorporating loss mechanisms found in manufacturable TAE products into simulations.

APPENDICES

Appendix 1: Cost Audit

Results of an audit by an Engineering Team in 12 July 2011 from a Blue-chip Powers Systems Manufacturing Company of Score-Stove™² predicted the volume prices below:

“1) Our best view of the current concept is that it will have a ‘fully burdened’ factory-gate selling price of circa £150 – transport and installation costs will be in addition. This is relative to a requirement of £25 for 80% of the target market, £40 for 10% and £60 for 3%. and includes fixed cost contribution and a profit element. Even at this price the concept does compete with other technologies on a £/watt basis.

2) The current concept requires more work to bring down costs further on requirements such as:

- Radiative heat to cooking is reduced compared with conventional stoves – the solution to this is at the early point of testing, which is to pre-heat the air ahead of combustion by drawing it over the heat exchanger using natural aspiration and also by using cooking pots that sit into the hob to increase surface area for convective heating, hence achieving comparative cooking times.
- Achieving the 100 W electricity target – 1.5 bar gauge mean pressure is required in the acoustic pipes; sealing issues need resolving to achieve this. Nottingham believes they will achieve 50 Watts at 0.5 to 1 bar gauge with current sealing techniques.

3) Major ideas the audit team and Nottingham brainstormed for cost reduction could reduce the ‘fully burdened’ factory gate selling price to £60 with the major items as below. (At £60 the stove would hit 3% of the market, which would be circa 15 million units)

By using mass manufacturing techniques and automotive process it was thought that the following higher cost items could be significantly cost reduced:

- radiator (using modern automotive aluminium design)
- regenerator (by lower cost material)
- convoluted heat exchanger (using mass production techniques and supplying directly from the foundry)

However whether these gains can be realised is uncertain and requires significant R&T.

4) Item 3) would provide electricity at £1.2 per Watt.

Head of Sustainability. [Name withheld]”

Appendix 2: Product Design Requirements

“

1. The product will primarily be designed for the residential market.
2. The product will be designed to operate with wood.
3. The product will enable cooks to control the amount of heat transferred to two cooking pots.
4. The size of the wood should resemble what is currently accepted. In Yanglakot this is normally less than 750 mm in length with a diameter of roughly 25 mm. Diameters of logs up to 60 mm should be accommodated.
5. The fuel opening of the cooking stove should be able to accommodate combinations of fuel wood sizes, whilst allowing the fire box to be semi-sealed. [Rocket stove design quotes 120x120mm for the fuel opening]
6. The product may need to incorporate a wood drying area. Almost 20 kg of wood is used over three days in the summer when no heating is required. [At maximum diameter of 60 mm this may be packed into an area of 0.04m³]
7. The product will reduce the amount of fuel burnt per head per day for cooking meals by at least 1/3 to 1.1 kg/person/day.
8. The product will provide 1.6kW (heat) or more to boil 4l of water in 15 minutes 4 times per day. This may be achieved by a hot plate (traditional) or non-conventional means (water heating system) and exceeds demand from a Yanglakot typical house. Electricity generation will be simultaneous.
9. The product will heat up to half electrical power in no more than 5 minutes.
10. The product will provide 0.76kW or more to simmer the same 4l of water for 2 hours without a lid on a hot plate, with simultaneous electricity generation.
11. The product should be able to output heat into the dwelling during the winter months to increase the temperature in the dwelling by at least 5 degrees centigrade.
12. The product will reduce current fuel consumption for heating alone by at least 1/3 per day.
13. Electricity generation will not interfere with the normal cooking process.
14. Electricity will be stored in batteries, normally car type - 13.6V. The battery will not be provided with the stove.
15. The product will output 300 Whr per day, with an output of 13.6 V which may be used directly or to charge a sealed lead acid battery, from 3 hours of full power stove operation.
16. The electrical output from stove will be DC, and current limited.
17. The facility to run devices directly from the thermo-acoustic engine would be beneficial, particularly if the cooking stove is operated when it is dark and/or cold, to preserve stored energy and prolong battery life.
18. The thermo-acoustic engine will be quiet; less than 50 dBa 1m from the unit.
19. The thermo-acoustic engine will be a sealed unit, and no maintenance will be required.

20. The cook stove design will reduce suspended particulate and carbon monoxide concentration in the surrounding air compared to the traditional three stone stove and endeavour to reach the Nepalese national ambient air quality targets of producing no more than 230 $\mu\text{g}/\text{m}^3$ total suspended particulates (TSP) (120 $\mu\text{g}/\text{m}^3$ PM10) over a 24 hour period, and no more than 9 ppm (10,000 $\mu\text{g}/\text{m}^3$) CO in an 8 hour period.
21. The flue length can be up to 3m high.
22. The product will consist of all preassembled parts and metalwork. If certain parts of the product can be made on site, these will not feature in the price [or the weight] restrictions. The unit price will be less than £20 per dwelling when delivered to the capital city or £40 if delivered and installed in a village dwelling.
23. The weight of the product will be less than 20kg
24. The size of the cook stove body should not be significantly larger in width and length than current areas use for cooking on traditional stoves, estimated at less than 1 m².
25. Raising the cooking surface to between 0.5 and 0.75 m, to achieve a standing cooking position, is preferable.
26. With regular maintenance the product will operate for over 5 years, without significant increases in fuel required or emissions produced. Maintenance will include regular ash removal and occasional joint integrity inspection.
27. A short instruction manual will be permanently fixed to the product [stamped in the surface of the product body]. The guide will provide information about stove operation and maintenance in pictorial form. Instruction in the local language will be available.
28. Smoke introduction into the dwelling shall be possible. [to remove insects]”

Appendix 3: Heat Exchanger convoluted design

Assuming that a bulge design and convoluted plate design have the same viewing angle and hence projected area from HHX to regenerator as shown in Figure 15, the total amount of heat transfer energy from flame to the HHX, in the case of the bulge is

$$Q_b = h_b A_b (T_{sb} - T_m) + \varepsilon \sigma A_b (T_{sb}^4 - T_m^4) \text{ and substituting for } T_{sb} \text{ gives}$$

$$Q_b = h_b A_b (T_{sc} T_r - T_m) + \varepsilon \sigma A_b (T_{sc}^4 T_r^4 - T_m^4) \quad (3)$$

for the case of the convoluted plate design

$$Q_c = h_c A_c (T_{sc} - T_m) + \varepsilon \sigma A_c (T_{sc}^4 - T_m^4) \quad (4)$$

where Q is the total heat transfer rate from the HHX to the regenerator (Q_b for the bulge and Q_c for convoluted plate)

h : heat transfer proportional to temperature includes convective and conductive elements (h_b for the bulge and h_c for convoluted plate)

A : heating area (A_b for bulge and A_c for convoluted plate)

T_{sc} : heat source temperature for convoluted plate

T_m : temperature of HHX

ε : emissivity

σ : Stephan-Boltzman constant

Making the substitutions $T_{sb} = T_{sc} T_r$ and $A_c = A_r A_b$ and Q_a is the required heat flow, T_r is the temperature ratio and A_r the areas ratio between the bulge case and convoluted plate case it can be shown that:

$$a T_r^4 + b T_r + c = 0 \quad (5)$$

where $a = \varepsilon \sigma T_{sc}^4$, $b = h_b T_{sc}$ and

$$c = T_{sc} h_c A_r - T_m (h_b + h_c A_r) + \varepsilon \sigma (T_{sc}^4 A_r - T_m^4 (A_r + 1)) - \frac{2Q_a}{A_b} \quad (6)$$

Solving for $T_{sc} = 923$ K (the lower measured wood temperature) and for a Q_a of 2.4 kW the required thermal heat flow, and assuming a nominal value for both heat transfer coefficients h of 30 W/m²/K, the area ratio A_r becomes 3.5 and the reduction in temperature from bulge to a convoluted plate with 3.5 times the area is 222 K. With the geometry as defined the closed match to this target figure was for $A_c = 0.222$ m².

This convoluted plate design is used in the Demo2 TAE in order to enable more heat to be transferred to the regenerator via conduction as one side of the convolutions is directly in touch with one side of the regenerator.

Appendix 4 Attachments to this Thesis:

- 4.1 Designing a Low-Cost, Electricity Generating Cooking Stove.*
- 4.2 Halbach array Linear Alternator for thermo-acoustic engine*
- 4.3 Investigation and Measurement of a Low-cost Loudspeaker ...*
- 4.4 Development of thermoacoustic engine operating by waste heat ...*
- 4.5 Towards a Transient Simulation of thermo-acoustic Engines*
- 4.6 Design and development of a low-cost, electricity-generating ... Stove*
- 4.7 Generating electricity in developing countries using thermo-acoustics ...*
- 4.8 Investigation of thermo-acoustically Driven Linear Alternator*
- 4.9 Presentation to the UK Parliamentary committee Dec 2009.*
- 4.10 Application of Thermo-acoustic, electrical generating engines ...*
- 4.11 Design and Testing of a Wood Burning Electricity Generator...*
- 4.12 Construction and Assessment of a Propane driven ... stove ...*
- 4.13 Development of Thermoacoustic Engine ...*
- 4.14 Improvement of the Travelling Wave Thermoacoustic Engine ...*
- 4.15 Investigation and Measurement of a Low-cost Loudspeaker ...*
- 4.16 Low-cost, electricity generating heat engines for rural areas*
- 4.17 Development and Assessment of a Score ... Engine*
- 4.18 Analysis of the effects of different types of loads ...*
- 4.19 Score Project Plan*
- 4.20 Score CA agreement*
- 4.21 Score Intellectual Property Agreement*
- 4.22 Score External Collaborators Agreement. (Template)*
- 4.23 Patent: heat exchanger arrangement*
- 4.24 Patent: Linear Alternator.*
- 4.25 Module1: the Score story*
- 4.26 Module2: thermo-acoustic background*
- 4.27 Community web site working practices document.*
- 4.28 Demo2 Installation Document.*

BIBLIOGRAPHY

- 1 Riley, P.H., and Johnson, C.M., "Designing a Low-Cost, Electricity Generating Cooking Stove", *Technology and Society Magazine IEEE*, summer 2010. Digital Object Identifier 10.1109/MTS.2010.937029, 1932-4529/10/\$26.00©2010IEEE.
- 2 Saha, C.R., Riley, P.H., Johnson, C.M., Paul J., Yu, Z., Jaworski, A. "Halbach array Linear Alternator for thermoacoustic engine" *Sensors & Actuators: A. Physical.*: 4-Mar-2012 DOI information: <http://dx.doi.org/10.1016/j.sna.2012.01.042>
- 3 Chen, B., Abdalla Abakr, Y., Riley, PH., Hann, D., "Investigation and Measurement of a Low-cost Loudspeaker as a Liner Alternation for Thermoacoustic Application. *Applied Mechanics and Materials*", 2011(submitted paper).
- 4 Chen, B., Abdalla Abakr, Y., Riley, PH., Hann, D., "Development of thermoacoustic engine operating by waste heat from cooking stove " *AIP Conf. Proc.* 1440, pp. 532-540; doi:<http://dx.doi.org/10.1063/1.4704259> (9 pages)
- 5 Riley, Paul H. "Towards a Transient Simulation of thermoacoustic Engines Using an Electrical Analogy." *Procedia Engineering* 56 (2013): 821-828.
- 6 B M Chen, P H Riley, Y A Abakr, K Pullen, D B Hann, and C M Johnson, Design and development of a low-cost, electricity-generating cooking Score-Stove™ *Proceedings of the Institution of Mechanical Engineers, Part A: Journal of Power and Energy* 0957650913498733, first published on September 5, 2013 as doi:10.1177/0957650913498733
- 7 Riley, PH., "Affordability for sustainable energy development products", paper submitted to *Journal of Applied energy*
- 8 Riley, PH., and Johnson, CM., "Generating electricity in developing countries using thermo-acoustics powered by burning wood", *Acoustics 08*, Paris, June 2008.
- 9 Riley, PH., and Johnson, CM., Saha, C.R., "Investigation of thermo-acoustically Driven Linear Alternator" *U21 Energy conference*, Birmingham UK, Sept 2008.
- 10 Riley P.H., Saha C., Johnson CM., Presentation to the UK Parliamentary committee Dec 2009. <http://www.parliament.uk/documents/upload/riley.pdf>
- 11 Riley P.H, Saha C., Johnson CM., "Application of Thermoacoustic, electrical generating engines in rural areas", *IIT Delhi* 7-9 September 2010.
- 12 Chen, B., Riley, PH., et al., "Design and Testing of a Wood Burning Electricity Generator by using Dual-Core Thermoacoustic Engine". 2011 World Congress on Engineering and Technology (CET), Shanghai, China, 2011.
- 13 Chen, B., Riley, PH., and Abakr, YA., "Construction and Assessment of a Propane driven, Electricity-Generating Cooking Score-Stove™" in *International congress on Green process Engineering 2011: Kuala Lumpur Malaysia*
- 14 Chen, B., Abdalla Abakr, Y., Riley, PH., Hann, D., "Development of Thermoacoustic Engine Operating by Waste Heat from Cooking Stove". *International Meeting of Advances in Thermofluids 4th IMAT 2011*. 2011: Melaka.
- 15 S.T. Wee, D.B. Hann, P. H. Riley, and Y. A. Abakr, "Improvement of the Travelling Wave Thermoacoustic Engine Feedback Loop", *International congress on Green process Engineering 2011: Kuala Lumpur, Malaysia*.
- 16 Chen, B., Abdalla Abakr, Y., Riley, PH., Hann, D., "Investigation and Measurement of a Low-cost Loudspeaker as a Liner Alternation for Thermoacoustic Application". 2011 *International Conference on Applied Mechanics, Materials and Manufacturing*. 2011: Shenzhen, China.
- 17 Riley P.H. "Low-cost, electricity generating heat engines for rural areas". *International conference on Low-cost, electricity generating heat engines for rural areas*. 2 3 April 2012 Nottingham UK.
- 18 Chen, B., Abdalla Abakr, Y., Riley, PH., Hann, D., "Development and Assessment of a Score Demo2.1 thermoacoustic Engine", *International conference on low-cost, electricity generating heat engines for rural areas*. 2 3 April 2012 Nottingham UK.
- 19 Saha, C., Riley, PH., and Johnson, CM., "Analysis of the effects of different types of loads on a thermo-acoustic Engine". *International conference on low-cost, electricity generating heat engines for rural areas*. 2 3 April 2012 Nottingham UK.
- 20 Score Project Plan (see Appendices)
- 21 Score CA agreement (see Appendices)
- 22 Score Intellectual Property Agreement (see Appendices)
- 23 Score External Collaborators Agreement. (Template) (see Appendices)
- 24 Patent: heat exchanger arrangement (see Appendices)
- 25 Patent: Linear Alternator (see Appendices)
- 26 Module 1: the Score story, https://dl.dropboxusercontent.com/u/102255847/module1_Thescorestory.ppt
- 27 Module2: thermo-acoustic background, <https://dl.dropboxusercontent.com/u/102255847/Module2TAEngies.ppt>
- 28 Score web site www.Score.uk.com
- 29 Community web site working practices document. <http://www.Score.uk.com/community/Shared%20Documents/SharePointworkingpractices.doc>
- 30 Riley PH., Saha C., Demo2 Installation Document.
- 31 DeBlok, K., "Low operating temperature integral thermoacoustic devices for solar cooling and waste heat recovery" *Acoustics08 Paris* 2008.
- 32 University of Nottingham Quality Manual
- 33 <http://climatechange.worldbank.org/sites/default/files/documents/Household%20Cookstoves-web.pdf>
- 34 <http://www.probec.org>
- 35 http://www.probec.org/fileuploads/fl10212007163006_ProBECinBrief.pdf
- 36 <http://www.thelancet.com/themed/global-burden-of-disease>
- 37 Hutton, G., Rehfuss, E., Tediosi, F. "Evaluation of the costs and benefits of interventions to reduce indoor air

- pollution” Energy for Sustainable Development Volume XI No. 4 December 2007.
- 38 <http://www.cleancookstoves.org/>
- 39 Obeng, G.Y., Akuffo, F.O., Braimah, I., Evers, HD., Mensah, E., “Impact of solar photovoltaic lighting on indoor air smoke in off-grid rural Ghana”, Energy for Sustainable Development Volume XII No. 1 March 2008.
- 40 Gurung, A, Ghimeray, A.K., Hassan, S.H.A, “The prospects of renewable energy technologies for rural electrification: A review from Nepal. Energy Policy40(2012)374–380.
- 41 Urmee, T., Harries, D., Schlapfer, A., “Issues related to rural electrification using renewable energy in developing countries of Asia and Pacific”. Renewable Energy 34 (2009) 354–357.
- 42 Hiremath, R.B., Kumar, B , Balachandra,P P., Ravindranath, N.H., Raghunandan, B.N. “Decentralised renewable energy: Scope, relevance and applications in the Indian context”, Energy for Sustainable Development 13 (2009) 4–10.
- 43 Riley, P.H., Saha, C., and Johnson, C.M., “Designing a Low-Cost, Electricity Generating Cooking Stove”, Technology and Society Magazine IEEE, summer 2010. Digital Object Identifier 10.1109/MTS.2010.937029, 1932-4529/10/\$26.00©2010IEEE.
- 44 Sanchez T et al. “Research into technology acceptance in rural communities in Kisumu, Kenya”. International conference on Low-cost, electricity generating heat engines for rural areas. 2 3 April 2012 Nottingham UK.
- 45 Mainali, B., Silveira, S., “Financing off-grid rural electrification: Country case Nepal” Energy 36 (2011) 2194e2201.
- 46 Paul J. Montgomery, Jr, “Low-cost Thermoacoustic Co-generator for Biomass-burning Cook Stoves.” November 16, 2010 2nd Pan-American/Iberian Meeting on Acoustics, Cancun, Mexico.
- 47 [http://www.unepfi.org/fileadmin/documents/Financing Renewable Energy in subSaharan Africa.pdf](http://www.unepfi.org/fileadmin/documents/Financing_Renewable_Energy_in_subSaharan_Africa.pdf)
- 48 <http://er.jsc.nasa.gov/seh/ricetalk.htm>
- 49 World Bank report “Household Cookstoves Environment, Health, and Climate Change” <http://climatechange.worldbank.org/sites/default/files/documents/Household%20Cookstoves-web.pdf>
- 50 <http://www.probec.net/displaysection.php?czacc=&zSelectedSectionID=sec1193008461>
- 51 <http://www.cleancookstoves.org/>
- 52 Hindustan article on termites
- 53 <http://www.sustainableenergyforall.org/>
- 54 http://www.google.co.uk/url?sa=t&rct=j&q=&esrc=s&frm=1&source=web&cd=1&cad=rja&ved=0CDcQFjAA&url=http%3A%2F%2Fwww.Score.uk.com%2Fresearch%2FShared%2520Documents%2FScore_Papers%2FList_of_Score_papers.doc&ei=ForhUNCNF6m00QWjgoDgDA&usg=AFQjCNHxuhYe3Chd_ytgjmGFPsMbsEcI4w&sig2=Idjd7KIPqrM0uxvqg0b-nw&bvm=bv.1355534169.d.d2k
- 55 International Conference on "Low-cost, electricity generating heat engines for rural areas" 2-3 April 2012, Nottingham, UK. <http://www.nottingham.ac.uk/lmh/>
- 56 <http://www.Score.uk.com/research/Lists/Score%20in%20the%20News/AllItems.aspx>
- 57 Practical Action initial requirements survey. <http://www.Score.uk.com/research/Shared%20Documents/Tchno-Social/Lessons%20-%20Practical%20Action.doc>
- 58 Sanchez T et al. “Research into technology acceptance in rural communities In Kisumu, Kenya” ”. International conference on Low-cost, electricity generating heat engines for rural areas. 2 3 April 2012 Nottingham UK.
- 59 Score Product Design Requirements Document. http://www.Score.uk.com/team/Shared%20Documents/WP1-requirements/ProductDesignRequirements_CG_QM.doc
- 60 S. L. Garrett, P. K. Hopke, and W. H. Behn, "A Research Road Map: Improved Cook Stove Development for Climate Change Mitigation and Women's and Children's Health", Report to the US State Department from the ASEAN-US Next-Generation Cook Stove Workshop (Nov 2009).
- 61 Teo Sanchez “Score initial social findings” http://www.Score.uk.com/research/Shared%20Documents/Tchno-Social/Technology_Acceptance_PA.ppt
- 62 Zhibin Yu, Artur J. Jaworski, Scott Backhaus. “DESIGN OF A LOW-COST THERMOACOUSTIC ELECTRICITY GENERATOR AND ITS EXPERIMENTAL VERIFICATION.” Proceedings of the 10th Biennial Conference on Engineering Systems Design and Analysis ESDA 10, July 12-14, 2010, Istanbul, Turkey, ESDA2010-24598
- 63 Lawn C., “Computational Modelling of a Thermo-Acoustic Travelling-Wave Engine”. Special edition of Journal of Power and Energy, 20913
- 64 CJL report on 150W requirement. Internal score document.
- 65 Swift G “Thermo-acoustics a unifying perspective for some engines and refrigerators”. ISBN 0-7354-0065-2
- 66 Backhaus S., “Thermoacoustic Electrical Cogeneration” ASEAN-US Next-Generation Cook Stove Workshop Oct 2011.
- 67 K deBlok, “Multi-stage-traveling-wave-feedback-thermoacoustics-in-practice”, ICSV19 Vilnius Lithuania July 2012 <http://www.aster-thermoacoustics.com/wp/wp-content/uploads/2012/08/Multi-stage-traveling-wave-feedback-thermoacoustics-in-practice-Kees-de-Blok.pdf>
- 68 Lawn CJ., “Assessment of the Performance of Regenerators in Travelling-Wave Thermoacoustic Engines” International Congress on Sound and Vibration, Vilnius, in July 2012.
- 69 Dennis R, Pullen K, “Development of a wood-fired cooking stove to incorporate a thermo-acoustic engine-generator unit”, International conference on Low-cost, electricity generating heat engines for rural areas. 2 3 April 2012 Nottingham UK.
- 70 DeltaEC. <http://www.lanl.gov/thermoacoustics/DeltaEC.html>
- 71 Zhang Xiao-yan, Sch. of Mech. Eng., Inner Mongolia Univ. of Sci. & Technol., Baotou, Mongolia “Fluent simulation of thermoacoustic effect”, Mechanic Automation and Control

-
- Engineering (MACE), 2011 Second International Conference. 15-17 July 2011. Page(s): 7391 – 7394.
- 72 C J Lawn “Assessment of the Performance of Regenerators in Travelling-Wave Thermoacoustic Engines” International Congress on Sound and Vibration, Vilnius, in July 2012.
- 73 Z Yu, AJ Jaworski and AS Abduljalil. “Fishbone-like instability in a looped-tube thermoacoustic engine” ACOUSTICAL SOC AMER INST PHYSICS Year: 2010 DOI identifier: 10.1121/1.3486198.
- 74 Aster Thermoacoustics,
<http://www.aster-thermoacoustics.com/?cat=4>
- 75 Bayram Arman, John Wollan, and Vince Kotsubo Praxair, Inc. Scott Backhaus and Greg Swift Los Alamos National Laboratory “Operation of Thermoacoustic Stirling Heat Engine Driven Large Multiple Pulse Tube Refrigerators” LA-UR-04-2820, submitted to the proceedings of the 13th Int'l Cryocooler Conf.
- 76 R.K. Shah; Ramesh K. Shah; Dusan P. Sekulic “Fundamentals of Heat Exchanger Design” ISBN 10: 0471321710 / 0-471-32171-0, ISBN 13: 9780471321712, Publisher: John Wiley & Sons Inc.
- 77 K. Halbach (1980). "Design of permanent multipole magnets with oriented rare earth cobalt material". Nuclear Instruments and Methods 169 (1): 1–10. Bibcode:1980NucIM.169....1H. doi:10.1016/0029-554X(80)90094-4. ISSN 0029-554X.
- 78 R. Scott Wakeland, “Use of electrodynamic drivers in thermo-acoustic refrigerators”, Journal of Acoustical Society of America, 107(2), February 2000
- 79 Fabio Immovilli, “Performance assessment of the University of Nottingham thermoacoustic stove test rig“ 27 August 2009, internal Score project document.
- 80 Kees deBlok, “ScoreII prototype demo at increased mean pressure”, Date: 09-11-2010 Version: 1. Internal Score document.
- 81 Kees deBlok “Exploring and validation of the new Score II concept” Date: 15-09-2010. Version: 0 (concept) Internal Score document.
- 82 S. .T. Wee, D.B.Hann, Y.A. Abakr, P.Riley “Velocity Based Wave Decomposition Technique for Acoustic Analysis of PIV measured Velocity Vector Maps”