

Makkar, H.P.S. (1985) Glycine biosynthesis in rat and sheep muscle. PhD thesis, University of Nottingham.

Access from the University of Nottingham repository:

<http://eprints.nottingham.ac.uk/13111/1/370552.pdf>

Copyright and reuse:

The Nottingham ePrints service makes this work by researchers of the University of Nottingham available open access under the following conditions.

This article is made available under the University of Nottingham End User licence and may be reused according to the conditions of the licence. For more details see:

http://eprints.nottingham.ac.uk/end_user_agreement.pdf

A note on versions:

The version presented here may differ from the published version or from the version of record. If you wish to cite this item you are advised to consult the publisher's version. Please see the repository url above for details on accessing the published version and note that access may require a subscription.

For more information, please contact eprints@nottingham.ac.uk

GLYCINE BIOSYNTHESIS IN RAT AND SHEEP MUSCLE

By

H.P.S.MAKKAR B.Sc. M.Sc. (A. Biochemistry)

Thesis submitted to the University of
Nottingham for the degree of Doctor of Philosophy

University of Nottingham
Faculty of Agricultural Science
School of Agriculture
Sutton Bonington
Loughborough, LE12 5RD

August 1985



CONTENTS

	Page
ABSTRACT	
PUBLICATIONS	
LIST OF TABLES	
LIST OF FIGURES	
ACKNOWLEDGEMENTS	
ABBREVIATIONS	
INTRODUCTION	
1.1. Functions of muscle	1
1.2. Release of amino acids from muscle	1
1.3. Efflux of alanine, glutamine and glycine from muscle	3
1.4. Roles of glycine in animals	4
1.4.a. Protein synthesis	4
1.4.b. Gluconeogenesis	5
1.4.c. Glutathione synthesis	6
1.4.d. Purine synthesis	7
1.4.e. Haem synthesis	8
1.4.f. Source of 'one-carbon' units	8
1.4.g. Phosphocreatine synthesis	10
1.4.h. Synthesis of acylglycines	11
1.4.i. Other roles	12
1.5. Biosynthesis of glycine	12
1.5.a. Glycine formation from serine	12
i) Sources of serine	16
1.5.b. Glycine formation from threonine	17
1.5.c. Glycine formation from glutamate	18
1.5.d. Glycine formation from sarcosine	19
1.5.e. Glycine formation from glyoxylate	20
1.6. Metabolism of amino acids in ruminant and non-ruminant muscle	21
1.7. Isolated perfused muscle preparations	23
1.8. Perfusion with erythrocyte-free medium	25
1.9 Objectives of the current study	26
MATERIALS AND METHODS	
2.1. Materials	28

2.2. Experimental animals and housing	30
2.2.a. Rats	30
2.2.b. Sheep	30
2.2.c. Trenbolone acetate and testosterone experiments	30
2.3. Determination of radioisotopes	31
2.4. Statistics	31
2.5. The rat hind-limb perfusion system	32
2.5.a. Perfusion apparatus	32
2.5.b. Perfusion medium	34
i) Composition of the medium	34
ii) Preparation of the medium	35
iii) Preparation of rat erythrocytes	35
iv) Haematocric	36
2.5.c. Surgical preparation of the hind-limb	36
2.5.d. Cleaning and sterilization procedures	39
2.6. The sheep hemidiaphragm perfusion system	40
2.6.a. Perfusion apparatus	40
2.6.b. Perfusion medium	40
i) Composition	40
ii) Preparation	41
2.6.c. Cannulation of diaphragm	41
2.6.d. Cleaning and sterilization of apparatus	43
2.7. Addition of radiochemicals	43
2.8. Sampling procedures	43
2.8.a. Perfusate	43
2.8.b. Muscle	44
2.9. Criteria to test perfusion viability	44
2.9.a. Potassium concentration	44
i) Perfusate	44
ii) Muscle	44
2.9.b. Muscle water content	45
2.9.c. Muscle extracellular space	45
2.9.d. Perfusate lactate concentration	46
2.9.e. Perfusate pyruvate concentration	47
2.9.f. Muscle ATP, ADP and AMP estimation	48
i) Sample preparation	48
ii) ATP determination	49
iii) ADP and AMP determination	50
2.9.g. Muscle pyruvate and lactate estimation	52
i) Preparation of sample	52
ii) Pyruvate determination	52
iii) Lactate determination	52
2.9.h. Glycogen determination	53

2.9.i. Measurement of oxygen uptake by sheep diaphragm	54
i) Calibration of electrode	54
ii) Measurement of oxygen concentration of 'arterial' and 'venous' perfusate	55
2.9.j. Determination of muscle creatine phosphate	56
2.10. Determination of weight of muscle perfused	58
2.10.a. Rat hind-limb	58
2.10.b. Sheep diaphragm	58
2.11. Glutathione determination	59
2.11.a. Reduced glutathione	59
2.11.b. Oxidised glutathione	61
2.12. Amino acid analysis	63
2.12.a. Plasma and whole perfusate amino acids	63
2.12.b. Preparation of the resin column	64
2.12.c. Muscle intracellular fluid (free) amino acids	64
2.12.d. Muscle protein-bound amino acids	65
2.12.e. Amino acid analysers	66
2.12.f. Internal standard	66
2.13. Intracellular metabolite concentration	67
2.14. Determination of ¹⁴ C amino acid radioactivity	67
2.14.a. Split-stream amino acid analyser	67
2.14.b. Matching of fractions collected to amino acid chromatograms	68
2.14.c. Sample preparation for split-stream analysis	68
2.15. Determination of serine hydroxymethyl-transferase activity	69
2.15.a. Organ removal and storage	69
2.15.b. Preparation and storage of tetrahydrofolate	70
2.15.c. Preparation of homogenates	70
2.15.d. Enzyme assay	71
i) Rat liver	72
ii) Sheep liver	73
iii) Rat diaphragm and hind-limb muscle	73
iv) Sheep diaphragm and hind-limb muscle	74
2.16. Estimation of C-1 label in radiolabelled glycine	74
2.17. Development of a method for determination of radioactivity in C-2 of glycine	76
2.17.a. Introduction	76
2.17.b. Principle	76
2.17.c. Method	77

2.17.d. Results and discussion	78
2.18. Determination of radioactivity in C-2 of glycine obtained from perfusion experiments by the chloramine T method	81
2.19. Preparation of resin (Dowex 50x8, H ⁺ form) column	84

RESULTS

A. Studies on viability of perfused organs

3.1. Viability tests of perfused organs	85
3.1.a. The rat hind-limb	85
i) Perfusion with erythrocyte-containing medium	85
a) Appearance and flow rate	85
b) Muscle water content	85
c) pH measurements	85
d) Perfusate potassium concentration	86
ii) Perfusion with erythrocyte-free medium	86
a) Appearance and flow rate	86
b) pH measurements	86
c) Perfusate potassium concentration	86
d) Muscle water content	87
e) Muscle lactate, pyruvate and lactate/pyruvate ratio	87
f) Muscle ATP, ADP and ATP/ADP ratio	87
3.1.b. The sheep diaphragm	87
i) Macroscopic appearance and flow rate	87
ii) pH measurements	88
iii) Muscle water content	88
iv) Muscle extracellular space	88
v) Loss of muscle potassium	89
vi) Lactate and pyruvate production	89
vii) Muscle glycogen content	89
viii) Muscle lactate, pyruvate and lactate/pyruvate ratio	89
ix) Muscle ATP, ADP and AMP content and ATP/ADP and (ATP)/(ADP+AMP) ratios	90
x) Muscle phosphocreatine content	91
xi) Oxygen consumption by the diaphragm	91
xii) Ratio of the efflux of amino acids to tyrosine efflux	92

B. Studies on the perfused rat hind-limb

3.2. Efflux of amino acids from the rat hind-limb	93
---	----

3.3. Origin of glycine in the perfused rat hind-limb	94
3.3.a. Hydrolysis of bovine serum albumin and intracellular protein ?	94
3.3.b. Intracellular amino acid concentrations in rat hind-limb muscle	94
3.3.c. Muscle and erythrocyte glutathione content	96
3.3.d. <i>De novo</i> synthesis of glycine	96
3.4. Synthesis of glycine from serine	97
3.4.a. Perfusion using the standard perfusion medium	97
3.4.b. Effect of addition of serine to the standard perfusion medium	98
3.4.c. Effect of 5-formyl tetrahydrofolate addition to the standard perfusion medium containing 0.2 mM serine	99
3.5. Incorporation of ^{14}C into amino acids from (U- ^{14}C)glucose	100
3.6. Incorporation of ^{14}C into amino acids from (U- ^{14}C)serine and (3- ^{14}C)serine	101
3.6.a. Specific activities of the labelled amino acids	101
3.6.b. Time course of glycine and serine radioactivity in the medium	102
3.6.c. Distribution of glycine and serine radioactivity	102
3.6.d. Specific activities of glycine and serine in the medium	103
3.6.e. Amount of glycine derived from serine in the perfused rat hind-limb	103
3.7. Effect of branched-chain keto acids on glycine synthase in the perfused rat hind-limb	105
3.8. Labelling of C-1 and C-2 of glycine	106
3.9. Synthesis of glycine from threonine	106
3.9.a. Incorporation of ^{14}C into glycine from (U- ^{14}C)threonine	107
3.9.b. Distribution of glycine and threonine radioactivity	107
3.10. Effect of branched-chain keto acids	108
3.10.a. Efflux of amino acids from the perfused rat hind-limb	108
3.10.b. Intracellular amino acid concentrations in rat hind-limb muscle	109

C. Studies on the perfused sheep diaphragm	
3.11. Origin of glycine in the perfused sheep diaphragm	110
3.11.a. Efflux of amino acids from the sheep diaphragm	110
3.11.b. Intracellular amino acid concentrations in the sheep diaphragm	111
3.11.c. Glutathione concentration of the sheep diaphragm	112
3.11.d. Hydrolysis of intracellular protein and bovine serum albumin ?	113
3.11.e. <i>De novo</i> synthesis of glycine	113
3.11.f. Amino acid to tyrosine ratio in the muscle protein	114
3.12. Synthesis of glycine from serine	115
3.12.a. Perfusion using the standard perfusion medium	115
3.12.b. Effect of addition of serine to the standard perfusion medium	116
3.12.c. Effect of 5-formyl tetrahydrofolate addition to the standard perfusion medium containing 0.2 mM serine	117
3.13. Incorporation of ^{14}C into amino acids from (U- ^{14}C)glucose	118
3.14. Incorporation of ^{14}C into amino acids from (U- ^{14}C)serine and (3- ^{14}C)serine	119
3.14.a. Specific activities of the labelled amino acids	119
3.14.b. Time course of glycine and serine radioactivity in the medium	120
3.14.c. Specific activities of glycine and serine in the medium	121
3.14.d. Amount of glycine derived from serine in the perfused sheep diaphragm	122
3.14.e. Distribution of glycine and serine radioactivity	122
3.15. Effect of branched-chain keto acids on glycine synthase in the perfused sheep diaphragm	123
3.16. Labelling of C-1 and C-2 of glycine	124
3.17. Synthesis of glycine from threonine	124
3.17.a. Incorporation of ^{14}C into glycine from (U- ^{14}C)threonine	125

3.17.b. Distribution of glycine and threonine radioactivity	125
3.18. Effect of branched-chain keto acids	126
3.18.a. Efflux of amino acids from the perfused sheep diaphragm	126
3.18.b. Intracellular amino acid concentrations in sheep diaphragm	127
D. Serine hydroxymethyltransferase activity	
3.19. Serine hydroxymethyltransferase activity of the rat and sheep tissues	128
3.19.a. Serine hydroxymethyltransferase activity in the rat tissues	128
3.19.b. Serine hydroxymethyltransferase activity in the sheep tissues	129
E. Glycine synthesis in anabolic conditions	
3.20. Glycine synthesis in the trenbolone acetate and testosterone treated rat	130
3.20.a. The trenbolone acetate treated rat	130
i) Effect of trenbolone acetate on growth rate of the rat	130
ii) Effect of trenbolone acetate on serine hydroxymethyltransferase activity	131
iii) Effect of trenbolone acetate on water content of the tissues	131
3.20.b. The testosterone treated rats	132
i) Effect of testosterone on growth rate of the rat	132
ii) Effect of testosterone on serine hydroxy-132 methyltransferase activity of the tissues	
DISCUSSION	
4.1. Comments on experimental techniques used	134
4.1.a. Isolated perfused muscle preparations	134
4.1.b. Tests of perfusion viability	137
i) The rat hind-limb preparation	137
ii) The sheep diaphragm preparation	140
4.2. Rate of glycine synthesis from serine--whole body studies	145
4.3. Efflux and synthesis of glycine from isolated muscles	148
4.3.a. The rat hind-limb	148

4.3.b. The sheep diaphragm	150
4.4. Glycine formation from serine in rat hind-limb and sheep diaphragm	152
4.5. Pathways of glycine formation from serine in muscle	156
4.6. Effect of branched-chain keto acids on glycine synthase in rat hind-limb and sheep diaphragm	159
4.7. Glycine and serine formation from glucose in rat hind-limb and sheep diaphragm	160
4.8. Incorporation of label from (U- ¹⁴ C)serine and (3- ¹⁴ C)serine into amino acids in rat hind-limb and sheep diaphragm	162
4.8.a. Incorporation of label into aspartate and alanine	163
4.8.b. Incorporation of label into methionine	165
4.8.c. Incorporation of label into cysteine	167
4.8.d. Incorporation of label into glutamate and glutamine	168
4.9. Glycine synthesis from threonine in rat hind-limb and sheep diaphragm	168
4.10. Effect of branched-chain keto acids on the metabolism of glycine in rat hind-limb and sheep diaphragm	170
4.11. Serine to glycine conversion in rat and sheep tissues	172
4.11.a. Capacity of serine to glycine conversion of liver and muscle	174
i) Rat	174
ii) Sheep	174
4.12. Synthesis of glycine in rat under various metabolic conditions	175
4.12.a. Trenbolone acetate treatment	175
4.12.b. Testosterone treatment	176
i) Action of trenbolone acetate and testosterone treatment on muscle serine hydroxymethyltransferase activity— some speculations	178
4.12.c. Protein deficiency	180
4.12.d. Starvation and diabetes	181
4.12.e. Control of serine metabolism in rat muscle— an hypothesis	181
4.13. Role of glycine synthase in glycine biosynthesis	182

4.14. 'Serine-glycine' cycle— an hypothesis	184
4.15. Possible physiological significance of glycine released by the muscle	186
4.16. Origin of glycine in rat and sheep muscle	188
4.17. Possible extensions of the present study	190

BIBLIOGRAPHY

ABSTRACT

Glycine is the third most abundant of the amino acids released by muscle. Perfused rat hind-limb and sheep diaphragm preparations were employed to study the origin of glycine produced by non-ruminant and ruminant muscle.

Neither the degradation of muscle and erythrocyte glutathione nor the 'leaching out' of the intracellular glycine pool contributed to the glycine released by either muscle. When the perfusions were carried out with the medium free of amino acids, the proteolysis accounted for 57% of the total glycine release by the rat hind-limb and 38% by the sheep diaphragm. Minimum *de novo* synthesis of glycine was 12.3 $\mu\text{mol}/3\text{ h}/30\text{ g}$ in the rat muscle and 10.3 $\mu\text{mol}/3\text{ h}/30\text{ g}$ in the sheep muscle. Addition of serine to the perfusion medium stimulated significantly both the rate of glycine efflux and total glycine production in the rat hind-limb. Similar results were obtained with the sheep diaphragm; however, the increases were not statistically significant. Addition of 5-formyl tetrahydrofolate, a specific inhibitor of serine hydroxymethyltransferase, SHMT (EC 2.1.2.1) significantly decreased the rate of glycine efflux from both the muscles. The observations using cold serine were confirmed with the experiments employing radioisotopes. Upto 40% of total glycine produced by the rat hind-limb was derived from serine, whereas in the sheep diaphragm it was only 4%. In both the muscles synthesis of glycine from serine was by SHMT and not glycine synthase (EC 2.1.2.10). Synthesis of glycine from threonine was negligible in both

the muscles. SHMT activity increased in liver, diaphragm and hind-limb muscle of female rats treated with trenbolone acetate or testosterone, anabolic agents.

Both the muscles incorporated ^{14}C from (U- ^{14}C)serine and (3- ^{14}C)serine to methionine, cystine, alanine, aspartate and glutamate + glutamine. The label from (U- ^{14}C)glucose was recovered in serine and glycine in the rat hind-limb but not in the sheep diaphragm.

A 'serine-glycine' cycle involving kidney and muscle is proposed. The possible significance of glycine released by muscle is discussed.

Development of a system for the perfusion of sheep diaphragm with erythrocyte-free medium, and a method for the determination of radioactivity in C-2 of glycine also form a part of the thesis.

PUBLICATIONS

Part of the work reported in this thesis is in press.

1. Makkar, H.P.S. and Buttery, P.J. (1985) Glycine formation from serine in isolated perfused rat hind-limb. *Biochem. Soc. Trans.*
2. Makkar, H.P.S. and Buttery, P.J. (1985) Serine transhydroxymethyltransferase (EC 2.1.2.1) activity in trenbolone acetate- and testosterone-treated rats. *Proc. Nutr. Soc.*

LIST OF TABLES

	Following page
1. Release of individual amino acids from muscles of various species (% of total output)	1
2. Composition of standard rat diet	30
3. Composition of sheep diet	30
4. Recoveries of amino acids from perfusate	63
5. Recoveries of tissue intracellular amino acids	65
6. Details of amino acid analysers operation	66
7. Effect of keeping the tubes at 135-137°C for different lengths of time on the recoveries of radioactivity in C-2 of glycine	78
8. Effect of different concentrations of glycine on the recoveries of radioactivity in C-2 of glycine at two different concentrations of chloramine T	79
9. Effect of different quantities of authentic (2- ¹⁴ C)glycine on the recoveries of C-2	79
10. Viability of the rat hind-limb perfused with erythrocyte-containing and erythrocyte-free medium	86
11. Viability of the perfused sheep diaphragm	90
12. Oxygen uptake by the sheep diaphragm at different flow rates	91
13. Ratio of individual amino acids to tyrosine for the efflux of amino acids from the perfused sheep diaphragm	92
14. Efflux of amino acids from the rat hind-limb	93
15. Amino acid composition of bovine serum albumin, BSA (fraction v)	94
16. Amino acid composition of rat hindquarter muscle protein	94
17. Intracellular amino acid concentrations in rat hind-limb muscle <i>in vivo</i> and in muscle perfused under different conditions	95
18. Amino acid concentrations in rat plasma	95

19. Glutathione concentration in rat hind-limb muscle and erythrocytes before and after perfusion	96
20. Effects of the addition of serine and 5-formyl tetrahydrofolate to the standard perfusion medium on the efflux of amino acids from the perfused rat hind-limb	97
21. Rates of glycine and tyrosine efflux from the perfused rat hind-limb under different conditions of perfusion	99
22. Incorporation of ^{14}C into amino acids from (U- ^{14}C)glucose in the perfused rat hind-limb	100
23. Production of radiolabelled amino acids from (U- ^{14}C)serine and (3- ^{14}C)serine	101
24. Distribution of glycine and serine radioactivity in the perfusion medium, muscle free amino acid pool and muscle protein-bound amino acids following perfusion of the rat hind-limb using (U- ^{14}C)serine	102
25. Specific activities of labelled glycine, (U- ^{14}C)serine and (3- ^{14}C)serine in the medium during perfusion of the rat hind-limb	103
26. Specific activity of methionine following perfusion of the rat hind-limb in absence and presence of branched-chain keto acids	105
27. Radioactivity in C-1 and C-2 of labelled glycine isolated following perfusion of the rat hind-limb with (U- ^{14}C)serine	106
28. Distribution of glycine and threonine radioactivity in perfusion medium, muscle free amino acid pool and muscle protein-bound amino acids following perfusion of the rat hind-limb using (U- ^{14}C)threonine	107
29. Effect of the addition of branched-chain keto acids to the standard perfusion medium containing 0.2 mM serine on the efflux of amino acids from the perfused rat hind-limb	108
30. Intracellular amino acid concentrations of rat hind-limb muscle <i>in vivo</i> and after perfusion with the standard perfusion medium (SPM) containing 0.2 mM serine and with the SPM containing both 0.2 mM serine and branched-chain keto acids	109

31. Efflux of amino acids from the sheep diaphragm	110
32. Intracellular concentrations of serine, glycine and tyrosine in the sheep diaphragm <i>in vivo</i> and perfused under different conditions	111
33. Amino acid composition of the sheep plasma	111
34. Glutathione concentration in the sheep diaphragm before and after perfusion	112
35. Amino acid composition of the sheep diaphragm	113
36. Amino acid composition in the fresh and the perfused sheep diaphragm protein	114
37. Effect of addition of serine and 5-formyl tetrahydrofolate to the standard perfusion medium on the efflux of amino acids from the perfused sheep diaphragm	115
38. Incorporation of ^{14}C into amino acids from (U- ^{14}C)glucose in the perfused sheep diaphragm	118
39. Production of labelled amino acids from (U- ^{14}C)serine and (3- ^{14}C)serine in the perfused sheep diaphragm	119
40. Glycine and serine radioactivity (% of initial serine radioactivity) in the perfusate during perfusion of the sheep diaphragm	120
41. Specific activities of labelled glycine, (U- ^{14}C)serine and (3- ^{14}C)serine in the perfusion medium during perfusion of the sheep diaphragm	121
42. Distribution of glycine and serine radioactivity following perfusion of the sheep diaphragm using (U- ^{14}C)serine	122
43. Specific activity of methionine following perfusion of the sheep diaphragm in absence and presence of branched-chain keto acids	124
44. Radioactivity in C-1 and C-2 of labelled glycine isolated following perfusion of the sheep diaphragm with (U- ^{14}C)serine	124
45. Specific activity of glycine following perfusion of the sheep diaphragm using (U- ^{14}C)threonine and (U- ^{14}C)serine	125
46. Distribution of glycine and threonine radioactivity following perfusion of the sheep diaphragm using (U- ^{14}C)threonine	125

47. Effect of addition of branched-chain keto acids in the standard perfusion medium containing 0.2mM serine on the efflux of amino acids from the sheep diaphragm	126
48. Intracellular amino acid concentrations of sheep diaphragm <i>in vivo</i> and after perfusion with the standard perfusion medium (SPM) containing 0.2 mM serine and with the SPM containing both 0.2 mM serine and branched-chain keto acids	127
49. Serine hydroxymethyltransferase activity of diaphragm, hind-limb muscle and liver of rat	128
50. Serine hydroxymethyltransferase activity of diaphragm, hind-limb muscle and liver of sheep	129
51. The effect of trenbolone acetate on growth rate of female rat	130
52. The effect of trenbolone acetate on the activity of serine hydroxymethyltransferase	131
53. The effect of testosterone on growth rate of female rat	132
54. The effect of testosterone on the activity of serine hydroxymethyltransferase	132
55. Calculation of glycine synthesis by sheep hindquarters from the data of Heitmann and Bergman (1980)	150

LIST OF FIGURES

	Following page
1. The glucose-alanine cycle	3
2. 'One-carbon' unit metabolism	9
3. Diagram of perfusion apparatus	32
4a. Vessels ligatured during the surgical preparation of isolated rat hind-limb	37
b. Entry of the catheter	
5. Diagram of the sheep diaphragm	41
6a. Diagram of the tray	42
b. Diagram of the screwclamp	
7. The calibration curve for determination of reduced glutathione	59
8. Diagram of split-stream amino acid analyser	67
9a. Effect of homogenate concentration on serine hydroxymethyltransferase activity of rat liver	73
b. Effect of time of incubation on serine hydroxymethyltransferase activity of rat liver	
10a. Effect of homogenate concentration on serine hydroxymethyltransferase activity of sheep liver	73
b. Effect of time of incubation on serine hydroxymethyltransferase activity of sheep liver	
11a. Effect of homogenate concentration on serine hydroxymethyltransferase activity of rat diaphragm	73
b. Effect of time of incubation on serine hydroxymethyltransferase activity of rat diaphragm	
12a. Effect of homogenate concentration on serine hydroxymethyltransferase activity of rat hind-limb muscle	73
b. Effect of time of incubation on serine hydroxymethyltransferase activity of rat hind-limb muscle	
13a. Effect of homogenate concentration on serine hydroxymethyltransferase activity of sheep diaphragm	73
b. Effect of time of incubation on serine hydroxymethyltransferase activity of sheep diaphragm	

14a.	Effect of homogenate concentration on serine hydroxymethyltransferase activity of sheep hind-limb muscle	73
b.	Effect of time of incubation on serine hydroxymethyltransferase activity of sheep hind-limb muscle	
15.	Apparatus for determination of radioactivity in C-1 of glycine	75
16.	Time course of glycine efflux from the perfused rat hind-limb	98
17.	Time course of serine and glycine radioactivity in the medium	102
18.	Specific activities of glycine and serine in the medium	103
19.	Time course of glycine efflux from the perfused sheep diaphragm	116
20.	Time course of glycine and serine radioactivity in the medium	120
21.	Specific activities of glycine and serine in the medium	121
22.	Effect of trenbolone acetate on weight gain in female rats	130
23.	Effect of trenbolone acetate on water content of tissues	131
24.	Effect of testosterone on weight gain in female rats	132
25.	Effect of testosterone on water content of tissues	132
26.	The physiological causes and consequences of inadequate perfusion	137
27.	Pathways of serine biosynthesis	161
28.	Formation of alanine and aspartate from serine	164
29.	'Serine-glycine' cycle-- an hypothesis	184
30.	Sources of glyoxylate	188

ACKNOWLEDGEMENTS

I express my gratitude to Professor P.J. Buttery for initially giving me the opportunity to work in his laboratory, and also for his guidance, cooperation and encouragement during the present study. Furthermore, I feel unique pleasure in extending him my sincere thanks and admiration for helping me to get permission from the Ministry of Agriculture, Govt. of India to stay here for the third year of my studies.

It behoves me to thank the following.

-Dr. B.G. Vernon and Dr. N.P.G. Shepperson respectively for demonstrating the perfused rat hind-limb and sheep diaphragm preparations.

-Dr. J.M.M. Harper for her suggestions in preparation of the manuscript.

-Mr. David Bozon for technical assistance with the amino acid analysis.

-Miss Chris Essex and Miss Chris Palmer for helping me to obtain chemicals and equipment.

-Mrs. Judi Simpson and Mr. Chris Freeman for care and attention of the sheep, and for their assistance in the transport of sheep to the slaughter house.

-Mr. John Corbett for purchasing and slaughtering the sheep, and for helping me in cannulation of the sheep diaphragm.

-Library staff for their helpful services.

-All the members of the Department for making my stay enjoyable and rewarding.

I am also indebted to Dr. S.S. Negi, former Officer-in-charge, I.V.R.I. Regional Station, Palampur and Dr. P.N. Bhat, Director, I.V.R.I., Izatnagar for their help in getting extension of my stay to complete these studies.

My thanks are also due to my wife for her sacrifices and understanding and to my parents for taking care of my younger daughter.

The Commonwealth Scholarship is gratefully acknowledged. I thank Indian Council of Agricultural Research for the grant of study leave to accept the scholarship.

ABBREVIATIONS

Where appropriate, abbreviations have been used in accordance with the Biochemical Journal recommendations to authors (*Biochem. J.* (1985) 225, 1-26). Non-standard abbreviations have been defined at appropriate places.

It is implied throughout this thesis that one is dealing with L-amino acids with the exception of DL-nor-leucine. Three-letter symbols for amino acids have been used in accordance with *Biochem. J.* (1984) 219, 345-373.

INTRODUCTION

1.1. FUNCTIONS OF MUSCLE

The primary function of muscle is the generation of movement for locomotion and for the maintenance of posture. The second function is to act as a large reservoir of body protein. Skeletal muscle forms about 43% of the body weight of an animal and 40% of total body protein (Wannemacher, 1975). This large amount of protein might be expected to play a quantitatively important role in the nitrogen economy of the animal. Muscle has been shown to provide amino acids for gluconeogenesis (Felig et al., 1970), and to quickly release amino acids in response to nutritional stress (Millward, 1975). The free amino acids pool of muscle can act as a good supply of amino acid for other organs of the body (Pawlack and Pion, 1968).

1.2. RELEASE OF AMINO ACIDS FROM MUSCLE

Numerous studies employing the measurement of arteriovenous differences across limbs, and work with isolated preparations of muscle have both shown that amino acids are released from muscle in rats (Ruderman and Berger, 1974; Ward, 1976; Vernon, 1977), sheep (Ballard et al., 1976; Lindsay et al., 1977; Coward and Buttery, 1982), cattle (Bell et al., 1975) and fasted man (Felig et al., 1970). There is a large production of alanine, glutamine and glycine (Table 1). After alanine and glutamine, glycine is the third most important loss of amino nitrogen from muscle (Ruderman and Berger, 1974; Ward, 1976; Vernon, 1977; Felig

Table 1. Release of individual amino acids from muscles of various species (% of total output)

Species (Muscle)	Amino acids					
	Ala	Gln	Gly	Ser	Pro	Glu
Rat ^a (diaphragm) ¹	11	25	9	6	5	6
Rat ^a (hind-limb) ¹	23	24.4	6.1	-	5	1.5
Rat ^b (hind-limb) ²	15.07 [21.8]	11.6 -	11.3 [12.4]	5.4 [8.1]	3.8 [6.2]	3.8 -
Human ^a (forearm) ³	30	9.9	10	2	8	-
Human ^a (forearm) ⁴	26	27	8	3	3	-
Human ^c (forearm) ⁵	28	-	18.9	-ve	5.5	-
Cattle ^a (hind-limb) ⁶	24	27	10	-	-	-ve
Sheep ^a (hind-limb) ⁷	21	10	24	4	7	0.5
Sheep ^a (hind-limb) ⁸	20	24	5	4	-	-ve
Sheep ^d (hind-limb) ⁹	24.7	26.4	21	-ve	-	-ve
Sheep ^d (hind-limb) ⁹	19.3	18.2	20.3	2.9	-	-ve
Sheep ^d (hind-limb) ¹⁰	36.3	27.7	28.6	-ve	-	-ve
Sheep ^e (diaphragm) ²	24.6	18	15.3	4.5	-	7.8

contd.

Table 1. Release of individual amino acids from muscles of various species (% of total output)

Species (Muscle)	Amino acids					
	Lys	His	Met	Phe	Tyr	Arg
Rat ^a (diaphragm) ¹	5.6	3.5	3.2	3.4	2.7	3.9
Rat ^a (hind-limb) ¹	8.7	-	1	3.5	3	2
Rat ^b (hind-limb) ²	12.6 [14.2]	2.9 3.5	1.2 [1.4]	2.5 [3.3]	1.7 [2.5]	4.9 [6.6]
Human ^a (forearm) ³	9.9	3.8	1.5	2.1	2.4	6.2
Human ^a (forearm) ⁴	8	2.6	1.3	1.9	1.9	3.5
Human ^c (forearm) ⁵	11.7	3.9	3.0	2.8	2.9	1.9
Cattle ^a (hind-limb) ⁶	-ve	0.5	5.8	3.7	0.5	2.7
Sheep ^a (hind-limb) ⁷	5.1	2.2	0.9	2.4	1.0	4.0
Sheep ^a (hind-limb) ⁸	-ve	2.8	-	3.8	3.8	-
Sheep ^d (hind-limb) ²	-ve	-	-	4.4	1.9	4.9
Sheep ^d (hind-limb) ⁹	4.8	-	-	5.5	2.6	3.5
Sheep ^d (hind-limb) ¹⁰	1.2	-	-	4.3	-ve	0.9
Sheep ^e (diaphragm) ²	-	-	-	3.8	3.2	-

contd

- a, taken from Lindsay and Buttery (1980)
- b, calculated from the data of Ward (1976); the values in square parentheses are from Vernon (1977)
- c, calculated from the data of Felig (1970)
- d, calculated from the data of Heitmann and Bergman (1980)
- e, calculated from the data of Shepperson (1983)

- 1, from 48 h fasted animal
- 2, from fed animal
- 3, from overnight fasted animal
- 4, from 60 h fasted animal
- 5, from 4-6 weeks fasted animal
- 6, from 20 h fasted animal
- 7, from 48-96 h fasted animal
- 8, from 144 h fasted animal
- 9, from 72 h fasted animal
- 10, from acidotic animal

et al., 1970; Felig and Wahren, 1971; Pozefsky et al, 1969; London and Foley, 1965; Coward and Buttery, 1982; Shepperson, 1983). In addition, glycine efflux from hind-limbs of sheep increases during fasting and acidosis (Heitmann and Bergman, 1980). Similarly in rats, glycine efflux from peripheral tissues, including muscle, skin and adipose tissue increases during fasting (Aikawa et al., 1973; Yamamoto et al., 1974). After a 4-6 week fast in man, although the output from muscle of most amino acids including glycine decreases, a significant output of glycine is still seen. The reduction in glycine output is much less than that of most amino acids including alanine (Felig et al., 1970). Recently Ebisawa et al. (1983) have reported that the glycine synthesis in muscle increases about 47-fold in protein deficient rats. Treatment with trenbolone acetate (TBA), an androgenic growth promoter increases the muscle intracellular glycine concentration (see Buttery, 1978). Also there is an increase in the efflux of glycine from perfused hind-limbs of TBA treated rats (Vernon, 1977). Much is known about the synthesis of alanine and glutamine in muscle and their importance in inter-organ transfer of carbon and nitrogen under different conditions (see reviews Lindsay and Buttery, 1980; Snell, 1980b,c; Snell and Duff, 1980; Lindsay, 1980; Ruderman, 1975), however, virtually no information is available on the origin of glycine in muscle. The physiological significance of this glycine release is also not clear.

1.3. EFFLUX OF ALANINE, GLUTAMINE AND GLYCINE FROM MUSCLE

The large production of alanine from muscle led to the proposal of the glucose-alanine cycle (Fig. 1). In this cycle, glucose taken up by the muscle is converted to pyruvate which is transaminated to alanine. The alanine is reconverted to glucose in the liver. It is suggested that this cycle plays a key role in gluconeogenesis with alanine representing the passage of gluconeogenic precursors from muscle to the liver, and the transport of nitrogen from the muscle (see Felig, 1981).

Glutamine is also released from muscle in quantities beyond that which is accounted for by the muscle proteolysis. Muscle does not possess the enzymatic apparatus to synthesise urea, therefore by releasing nitrogen as glutamine, it is able to utilise amino acids without risk of either trapping excessive amounts of 2-ketoglutarate and oxaloacetate and thus inhibiting the tricarboxylic acid cycle or releasing a large quantity of ammonia into the circulation (see Ruderman, 1976).

There is also a large production of glycine from the muscle (see section 1.2.). Serine and glycine is a interconvertible couplet. A number of workers have observed extraction of serine from muscle (see section 1.5.a.), which suggests that serine could be a precursor of glycine in muscle. In addition, serine is synthesised from glycine in kidney (Rowell et al., 1982).

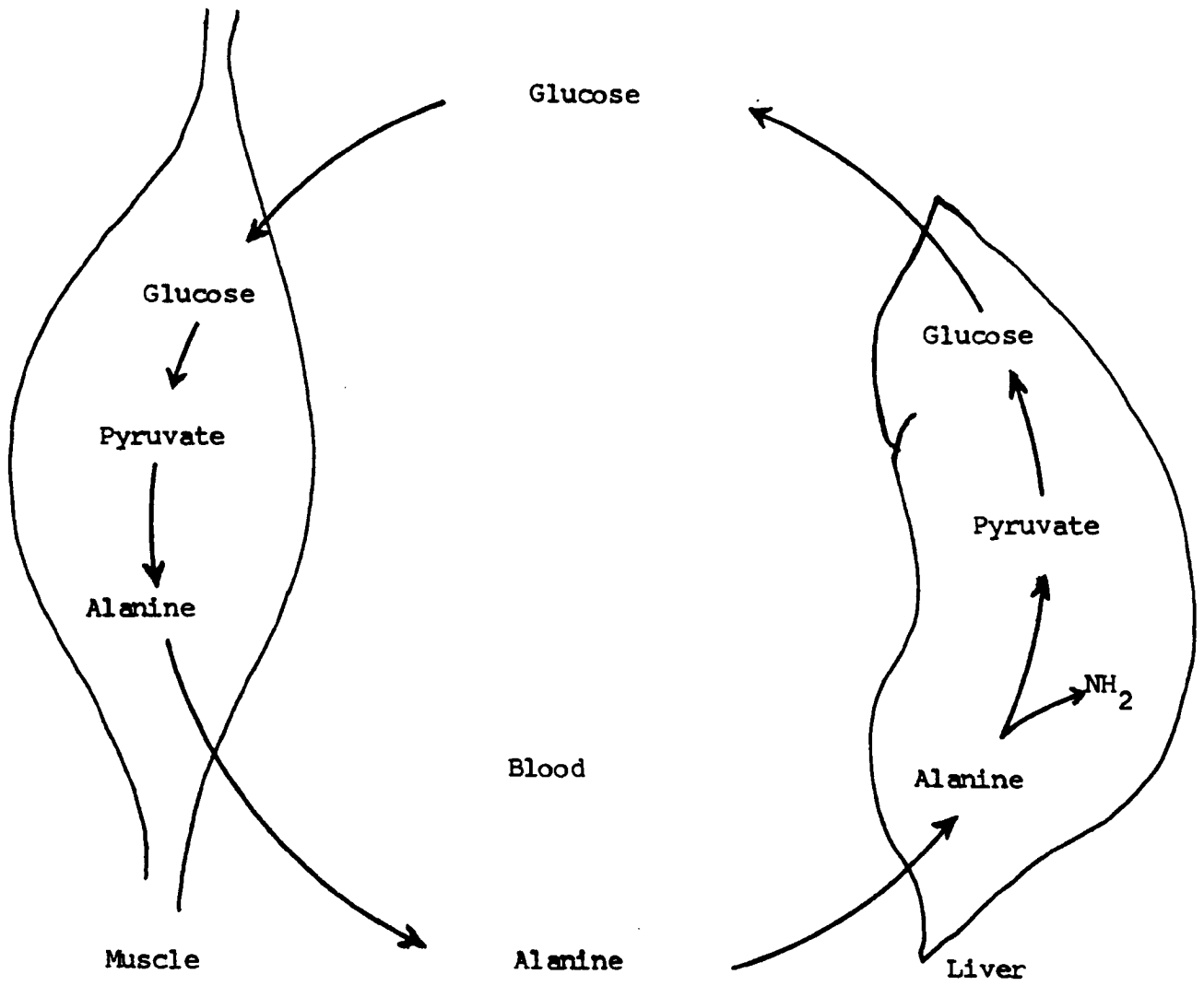

Fig. 1 The glucose - alanine cycle

Serine to glycine conversion is accompanied by the synthesis of 'one-carbon' units (see Blakely, 1969). Both glycine and 'one-carbon' units take part in various synthetic reactions. Also the glycine efflux increases in different metabolic conditions (see section 1.2.).

Increased release of glycine in acidosis from muscle suggests that glycine could act as a nitrogen carrier from muscle in a manner similar to alanine and glutamine.

From the above some of the questions which arise are:

-Is there a 'serine-glycine' cycle analogous to the 'alanine cycle' in muscle, and if it exists what is its physiological significance ?

-Is muscle synthesising 'one-carbon' units along with glycine ?

-Is there increased need of 'one-carbon' units under conditions of increased glycine release ?

-In muscle, from where and how does glycine obtain its nitrogen ?

The information on the origin of glycine and its pathways of biosynthesis in muscle would give a better insight into the questions raised above.

1.4. ROLES OF GLYCINE IN ANIMALS

1.4.a. Protein synthesis

Glycine was the first amino acid to be isolated from a protein when Braconnet in 1820 isolated glycine from a gelatine hydrolysate. Since it has a sweet taste he called

it "sucre de gelatine". In 1846 Horsford determined its elementary composition and called it 'glycocoll'. Berzelius suggested the name 'glycine' in 1848 and since then it has been called by this name (see Neuberger, 1981; Meister, 1965). Glycine forms about 4.9% of most mammalian proteins. However, in collagen (20-25% of total body protein) about 30% of the amino acids are glycine (see Neuberger, 1981). Collagen is considered almost inert as its turnover is very low (Neuberger, 1951; Robin, 1982).

1.4.b. Gluconeogenesis

Glycine is gluconeogenic because of its conversion to serine. Gluconeogenesis from glycine and serine has been demonstrated in the livers of rat, cat and sheep (Aikawa *et al.*, 1972; Beliveau and Freeland, 1982b; Wolf and Bergman, 1972a; Ishikawa *et al.*, 1972; Remesy *et al.*, 1983). Exton and Park (1967) found gluconeogenesis from both serine and alanine in perfused livers of fasted rats to be almost equal. In sheep liver, alanine was found to be better substrate for gluconeogenesis than serine or glycine (Wolff and Bergman, 1972). Other reports are in conflict as to the relative merits of serine, alanine and glycine as gluconeogenic precursors (Aikawa *et al.*, 1972; Ross *et al.*, 1967). The gluconeogenic amino acids, alanine, glycine and serine do however form 70% of total amino acids removed by the liver in the fed sheep (Bergman and Heitmann, 1978).

1.4.c. Glutathione synthesis

The biosynthesis of glutathione (L- γ -glutamyl-L-cysteinyl-glycine) involves the formation of γ -glutamyl-cysteine from L-cysteine and L-glutamate by the enzyme γ -glutamylcysteine synthetase. Glycine combines with γ -glutamylcysteine to give glutathione. The enzyme catalysing this reaction is glutathione synthetase. Both reactions use one mole of ATP.

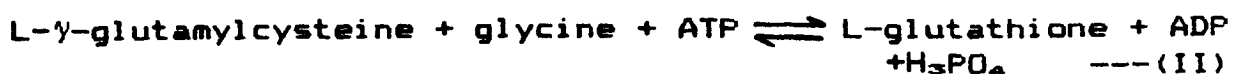

This tripeptide occurs in almost all cells. Although great attention has been given to the biochemistry of glutathione, its biological functions are not fully known. The free -SH group of glutathione helps in maintaining the -SH groups of proteins in reduced form (-SH groups are essential for activity of a number of enzymes), in the thiol-disulphide reaction in the cell, in reactions involving reducing groups or potentially reducing groups (not necessarily containing -SH groups) such as dehydroascorbic acid, and also in a number of detoxification reactions, e.g. in the reaction with H_2O_2 , reduction of peroxides arising from mercapturic acids (see Neuberger, 1981). Glutathione is also considered to participate in the cellular transport of amino acids especially in the kidney (Meister, 1975). However, it is yet not known how important

the metabolic glutathione cycle is either in kidney or other tissues. Roles for glutathione in anemia, acidosis, detoxification of drugs and the apparent renal secretion of cystine have also been suggested (see Neuberger, 1981; Robins and Davies, 1985).

1.4.d. Purine synthesis

The origin of the atoms of purine nucleus is presented below.

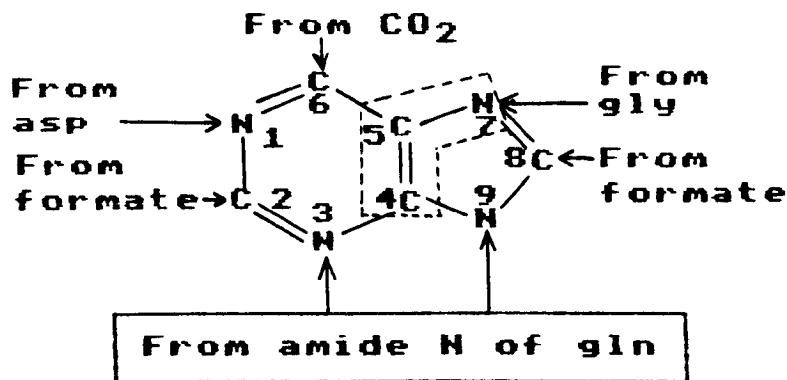

Glycine contributes carbon atoms at positions 4 and 5 and nitrogen at 7. The pathways for the purine biosynthesis have been studied in mammals, birds, yeast and bacteria (White et al., 1964). The reaction which involves glycine is:

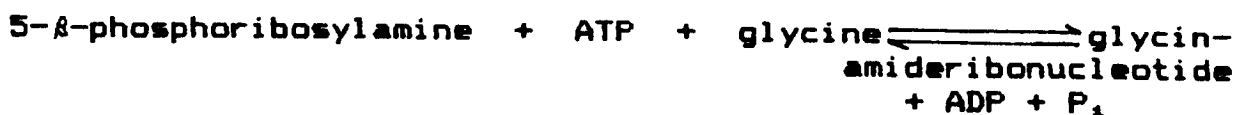

Purine nucleotides can be synthesised by two pathways, the 'de novo' pathway and the 'salvage' pathway. The 'salvage' pathway eliminates the need for purine synthesis, which is costly (synthesis of one purine nucleus requires cleavage of at least 5 ATPs) as it uses preformed purine

bases and nucleosides (see Neuberger, 1981). The *de novo* pathway accounts for about 10% of glycine metabolism (Nyhan, 1983). In humans about 2 $\mu\text{mol}/(\text{Kg body wt/h})$ glycine are required for purine synthesis (Wyngaarden and Kelly, 1982). The synthesis of uric acid from glycine in perfused chick liver requires 1.49 mole of oxygen which is equivalent to the production of 9 mole of ATP/mol of uric acid (Barratt et al., 1974). In animals most of the information on purine biosynthesis refers to liver, although recently evidence has been presented for the *de novo* synthesis of purines in rat muscle (Sheehan and Tully, 1983).

1.4.e. Haem synthesis

Eight carbon atoms and 4 nitrogen atoms of the porphyrin moiety of haem are derived from the 8 molecules of glycine used in the biosynthesis of each haem molecule. The reaction in the synthesis of haem which involves glycine is the initial and rate limiting step.

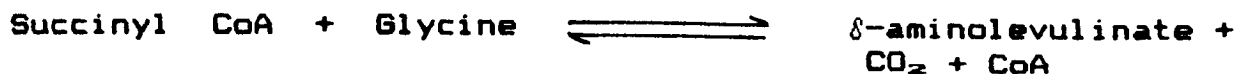

It is catalysed by δ -aminolevulinate synthase. The enzyme is located in the mitochondria (for details of biosynthesis of haemin see Tait, 1978; Cunningham, 1978).

1.4.f. Source of 'one-carbon' units

The conversion of serine to glycine by serine hydroxymethyltransferase (EC 2.1.2.1.) (reaction 1) and the catabolism of glycine by the glycine cleavage complex

(EC 2.1.2.10) (reaction II) produce 'one-carbon' units.

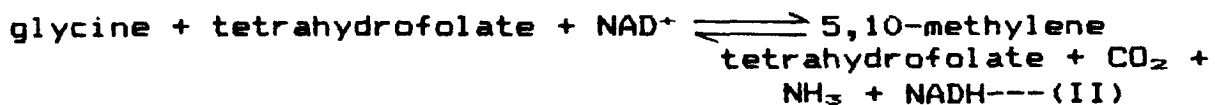
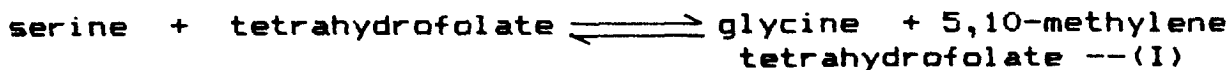

In reaction I, C-3 of serine and in reaction II, C-2 of glycine are released as 'one-carbon' units. In experiments with rats fed a diet containing no methionine, but homocystine, 70% of the radioactivity of the C-3 of serine was incorporated into the methyl group of the methionine isolated from the body tissues (see Neuberger, 1981). Similarly, Kretchmar and Price (1969) found that in mice about 71% of C-3 of serine was oxidised via the formate pathway. These observations suggest that serine to glycine conversion provides a significant quantity of 'one-carbon' units in the body. The other sources of formate and methyl groups in the body are sarcosine, betaine, choline, histidine and tryptophan (see Neuberger, 1981).

The most important carrier of 'one-carbon' units is tetrahydrofolate (THF). The 'one-carbon' units generated from the reactions mentioned above are substituted onto THF which can be converted by specific enzymes to other THF derivatives (Fig. 2). 10-Formyl-THF donates its 'one-carbon' units to one of the two 'one-carbon' units used in purine synthesis (C-2 of purine) and 5,10-methenyl-THF provides the other formate group (C-8 of purine). 5,10-Methylene-THF is also responsible for the addition of 'one-carbon' units to thymidylate, a rate limiting step in the synthesis of DNA

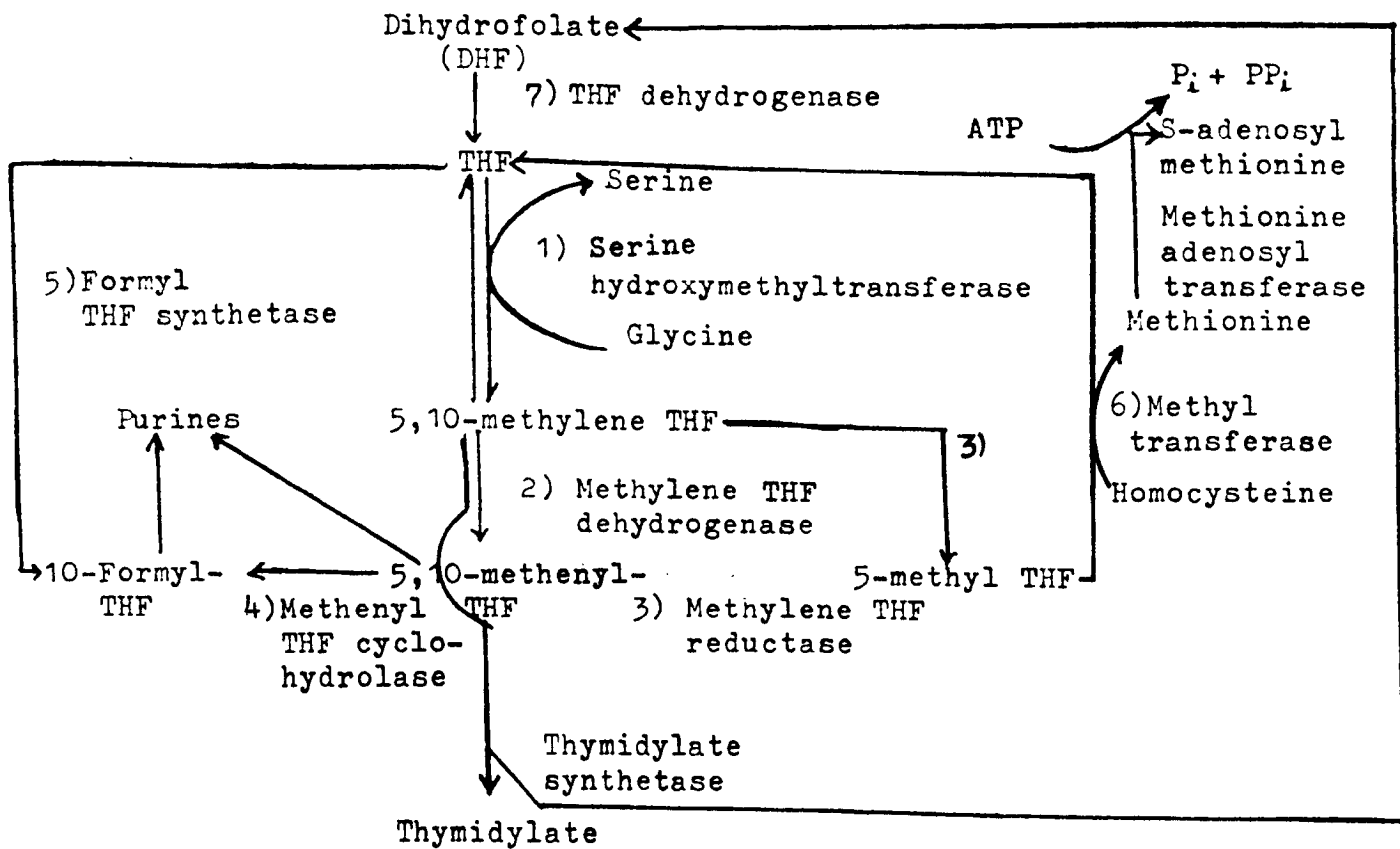
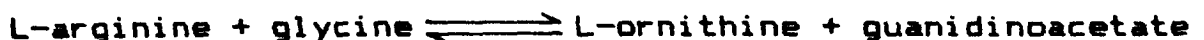

Fig. 2 'One - carbon' unit metabolism

(Herbert and Das, 1976). The methyl group of methionine is derived from 5-methyl-THF which donates its methyl group to homocysteine. Methionine is converted to S-adenosyl-methionine by an enzymic reaction which utilizes ATP. The S-adenosyl-methionine so formed also acts as a methyl donor in the cell. These reactions are presented in Fig. 2. The first reaction — conversion of serine to glycine is the most important reaction in the metabolism of 'one-carbon' units as serine hydroxymethyltransferase channels 'one-carbon' units from serine into the folate system.

1.4.g. Phosphocreatine synthesis

Creatine is formed by a sequence of two reactions, glycine being a substrate in the first reaction in which amide group is transferred from arginine to glycine. The reaction is catalysed by glycine amidotransferase.



The guanidino acetate is then methylated by a methyl transferase to form creatine. S-Adenosyl-methionine acts as the methyl donor in the reaction. The formation of guanidinoacetate is rate limiting step for the synthesis of creatine.

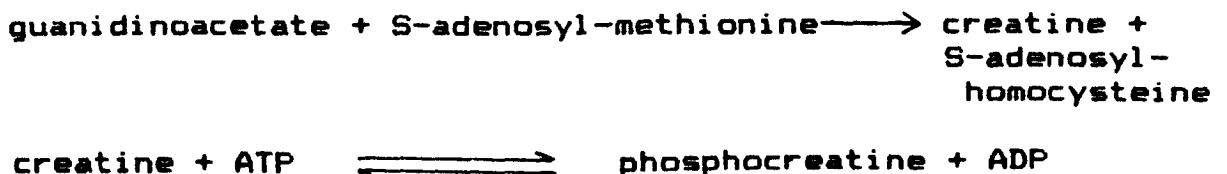

The creatine is then phosphorylated by creatine kinase to give phosphocreatine. Phosphocreatine serves as a reservoir for chemical energy because of the reversibility of the above reaction in which it can return its phosphoryl group to ADP, thus generating ATP. This occurs in muscle, for example, during muscular activity when the demand for ATP is increased due to its utilisation in muscle contraction (Cunningham, 1978). Creatinine can be readily formed non-enzymatically from phosphocreatine, and this is excreted in urine (see Neuberger, 1981). The requirement of glycine for creatine synthesis in man is about 8 $\mu\text{mol/h/Kg}$ body wt (Reeds, 1981).

1.4.h. Synthesis of acylglycines

Bile salts are formed in the liver and excreted into bile in a conjugated form. Conjugation takes place with glycine or taurine. In human bile, most of the bile is in the form of glycine conjugates.

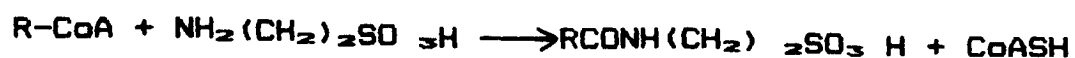
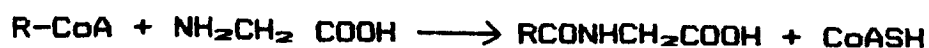
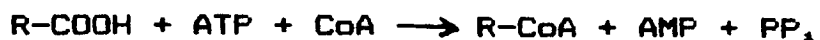

R-COOH could be benzoic acid, salicylic acid, phenylacetic acid or other aliphatic and aromatic acids. The above reactions take place in the liver cytosol. The efficiency of hippuric acid formation after feeding a standard amount of benzoic acid has been used as a liver function test (see Neuberger, 1981).

1.4.i. Other roles

In recent years it has been suggested that glycine plays a vital role in the central nervous system (CNS). It has been reported to have an inhibitory neurotransmitter activity in the spinal cord (Aprison and Daly, 1978). A neurotransmitter role for glycine has also been postulated in higher areas of CNS (Pycock and Kerwin, 1981).

Glycine and serine are interconvertible in the animal body and so indirectly glycine can take part in the synthesis of phosphatides, sphingosines and cysteine, as synthesis of these compound take place from serine (see Neuberger, 1981).

1.5. BIOSYNTHESIS OF GLYCINE

1.5.a. Glycine formation from serine

The major source of glycine in the body is serine (Evered, 1981; Blakelay, 1969). The release of glycine from muscle is accompanied by the removal of serine (Felig et al., 1970; Heitmann and Bergman, 1980; Aikawa et al., 1973; Brosnan et al., 1983). In hind-limbs of protein deficient rats, the increased synthesis of glycine is accompanied by increased catabolism of serine (Ebisawa et al., 1983). Furthermore, Ward et al. (1982) observed that serine is extracted by perfused rat hind-limbs. These observations suggest that serine could be a precursor for the synthesis of glycine in muscle. One of the enzymes catalysing the conversion of serine to glycine is serine hydroxymethyltransferase (SHMT) (EC 2.1.2.1., L-serine:

tetrahydrofolate 5,10-methylene transferase).

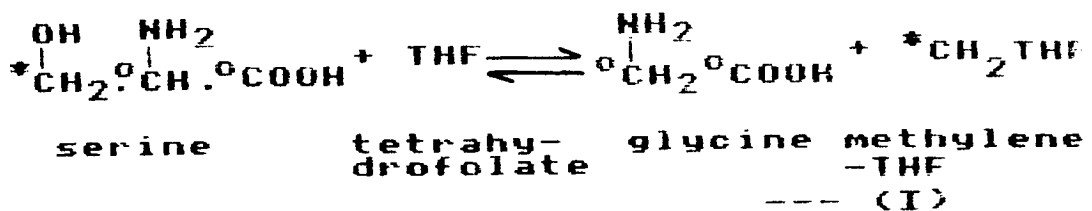

The enzyme is present both in the cytosol and mitochondria (Fuzioka, 1969). In liver these two enzymes have been reported to be different and may play a different physiological role (Chasin et al., 1974). The above reaction is a pyridoxal dependent. The mechanism of action of the enzyme and the stereochemistry of the reaction have been investigated (Jordan and Akhtar, 1970; Akhtar et al., 1975; Cheng and Schirch, 1973; 1982). SHMT is a regulatory enzyme and its activity is modulated by a number of metabolites like 5-methyl tetrahydrofolate, 5-formyl tetrahydrofolate, glycine, NAD⁺, NADH, NADPH etc. (Krebs and Hems, 1975; Ramesh and Rao, 1978, 1980; Schirch, 1982). The SHMT from rabbit liver has been crystallised (Schirch et al., 1981) and the elucidation of its three-dimensional structure has now become possible. Chemical modification of amino acid residues of SHMT from sheep liver has suggested that at least one residue each of arginine, cysteine and histidine are essential for its activity (Monohar and Rao, 1984).

Glycine can also be synthesised from serine by glycine synthase (EC 2.1.2.10), a reverse of the glycine-cleavage system (Kikuchi et al., 1980).

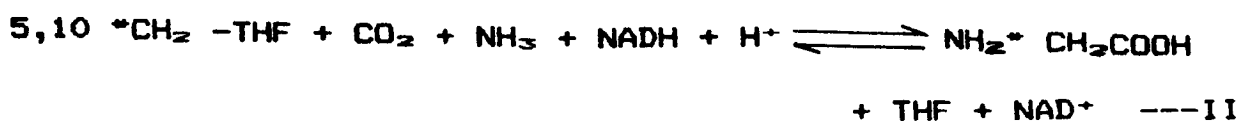

The methylene group of 5,10-methylene tetrahydrofolate is derived from C-3 of serine by the action of SHMT. However, 5,10-methylene tetrahydrofolate could also arise from other sources (see section 1.4.f.). Reactions I and II are independent of each other. The combined action of SHMT and glycine synthase produces 2 moles of glycine from one mole of serine.

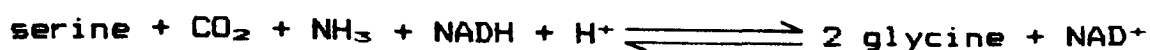

Use of rat mitochondrial extracts has shown that in glycine synthesis the C-3 of serine and bicarbonate were incorporated specifically into the C-2 and the carboxyl carbon of glycine, respectively, in a stoichiometric ratio of one. Ammonia is a direct and specific amino nitrogen donor. The enzyme system is reversible and present in liver, kidney, brain and testis and confined to mitochondria in all the tissues examined (Kikuchi, 1973). The branched-chain keto acids, α -ketoisovaleric acid, α -ketoisocaproic acid and α -keto- β -methylvaleric acid were found to stimulate glycine synthesis by glycine synthase 4-fold (O'Brien, 1978). It is interesting to note that branched-chain amino acids (BCAAs) are degraded to branched-chain keto acids in muscle (Harper et al., 1984). The degradation of BCAAs in ruminant muscle is lower than that in non-ruminant muscle (Lindsay and Buttery, 1980). Some evidence is available for the increase of glycine efflux from the perfused muscle when the medium contains BCAAs. When the perfusion medium

contained leucine (10 mM) there was a slight increase in the efflux of glycine (Ruderman and Berger, 1974). Similarly in the perfused sheep diaphragm, elevation of leucine to 10 times the normal plasma leucine concentration in a medium containing insulin but no β -hydroxybutyrate (a known inhibitor of BCAAs degradation, Landaas, 1977; Buffington *et al.*, 1979; Buse *et al.*, 1972) gave a 3-fold increase in the glycine efflux. However, no increase in the glycine efflux from sheep diaphragms was observed when the medium contained BCAAs at 10 times the plasma BCAAs concentration (insulin absent) (Shepperson, 1983). Also no change in the glycine efflux was recorded from rat diaphragms in the presence of BCAAs (Chang and Goldberg, 1978b).

The glycine synthase (glycine-cleavage system) consists of four protein components. i) P-protein (contains pyridoxal phosphate), ii) H-protein (contains lipoic acid), iii) T-protein (catalysis the tetrahydrofolate-dependent step), and iv) L-protein (a lipoamide dehydrogenase). These proteins are sometimes also called E₁, E₂, E₃, and E₄ respectively (Nyhan, 1982). The reactions catalysed by these four proteins are reversible. In both glycine synthesis and glycine cleavage, an aminomethyl moiety bound to the lipoic acid of H-protein is an intermediate. It can be formed from or degraded to 5,10-methylene tetrahydrofolate and ammonia by the T-protein. The P-protein requires H-protein for decarboxylation of glycine. Also, P-protein can itself catalyse the exchange reaction between the carboxyl carbon of glycine and bicarbonate but this exchange reaction is increased in the presence of H-protein (Kikuchi *et al.*,

1980). The contribution of glycine synthase towards glycine synthesis in animal body is not known (see Neuberger, 1981).

In addition to the above two pathways, glycine can be synthesised from serine via ethanolamine and glyoxylate (Nyhan, 1982).

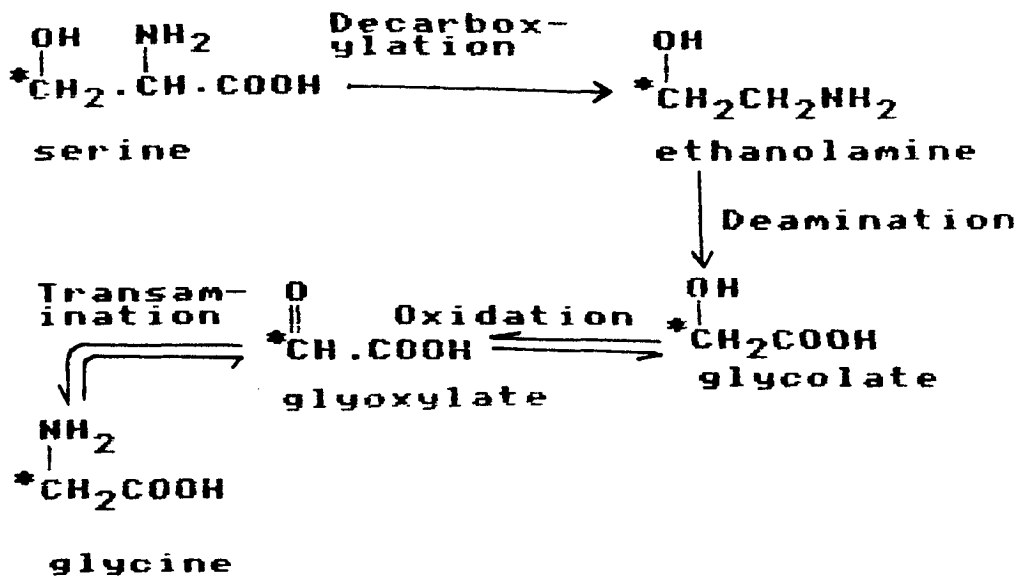

1.5.a.i. Sources of serine

As mentioned above, the principal source of glycine in mammals is serine. The serine can be of dietary origin or can be synthesised from glucose. Two pathways, both arising from glycolysis and called 'phosphorylated' and 'non-phosphorylated' have been proposed for the synthesis of serine from glucose in animal tissues (Evered, 1981). Both the pathways are functional in animal systems, though the relative contribution of these pathways for serine synthesis is not the same in all tissues. The results suggest that the

(Bird and Nunn, 1983; Dale, 1978; Bird et al., 1982) and in bacteria (McGilvray and Morris, 1969). There has been disagreement whether SHMT has also threonine aldolase activity (Schirch and Gross, 1968). However, a highly purified preparation of SHMT from rat liver cytosol (Palekar et al., 1973) did not catalyse the degradation of threonine to glycine, indicating that threonine aldolase was a separate enzyme. The observation that the maximum activity of threonine aldolase is too low to account for the amount of glycine produced (Bird and Nunn, 1979) has generated interest in the second pathway catalysed by threonine dehydrogenase. In rat liver threonine dehydrogenase accounts for 87% of the total threonine catabolised in the normally fed state, and this enzyme is considered to play a major role in producing glycine from threonine in the rat (Bird and Nunn, 1983). However, no information is available on glycine synthesis from threonine in muscle. The metabolism of threonine in ruminant muscle needs particular attention as there is evidence that threonine metabolism in ruminants differs from that in non-ruminants (see Morton, 1980).

1.5.c. Glycine formation from glutamate

Leuthardt (1941) reported that if guinea-pig liver slices were incubated with L-glutamate as much hippurate (benzoylglycine) was produced as with glycine itself. Direct supply of the whole glycine molecule from glutamate or from glutamine, i.e. hydroxylation at C-3 and then cleavage between the C-2 and C-3 of glutamate was suggested by Leuthardt (1941). The suggestion was later disputed (Shemin,

1949). L-Glutamate was much less effective than glutamine in producing hippurate. But this could be explained by a permeability barrier. L-Glutamine can penetrate cells easily whereas glutamate cannot (Hems *et al.*, 1968). The glutamine is readily hydrolysed to L-glutamate inside the cell (Schwerin *et al.*, 1950). Studies using ^{14}C glutamate labelled in different positions (C-2 and C-5) suggested conversion of L-glutamate into 4-hydroxy-2-oxoglutarate and scission of the latter to yield glyoxylate and pyruvate (Rowsell *et al.*, 1975). The glyoxylate could be converted to glycine by its transamination by the liver alanine-glyoxylate aminotransferase (Rowsell *et al.*, 1972).

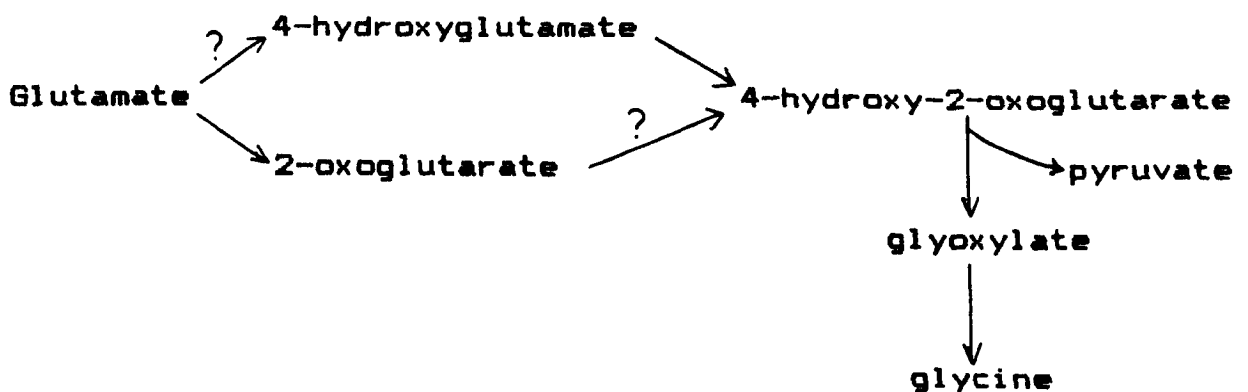

Marked oxidation of glutamate occurs in muscle (Ebisawa *et al.*, 1983; Ward, 1976; Shepperson, 1983). The majority appears to be utilised in the formation of glutamine (Chang and Goldberg, 1978a). However, it is not known if any glutamate is converted to glycine in muscle.

1.5.d. Glycine formation from sarcosine

Glycine can also be synthesised from sarcosine (N-methylglycine) by the action of sarcosine dehydrogenase

(EC 1.5.99.1), a mitochondrial enzyme (Hagge et al., 1967).

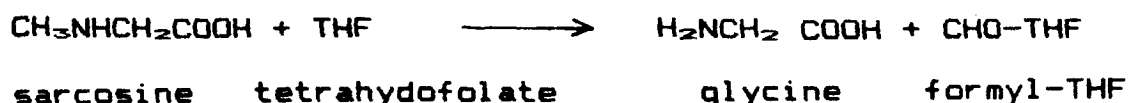

The source of sarcosine could be betaine (Gerritsen and Waisman, 1978). The synthesis of glycine from sarcosine does not appear to be of any quantitative significance, as loading studies with sarcosine revealed its slow disappearance and no elevation of the glycine concentration in the plasma (Hagge et al., 1967; Glorieux et al., 1971).

1.5.e. Glycine formation from glyoxylate

The synthesis of glycine from glyoxylate takes place by glycine transaminase. The sources of glyoxylate could be either serine via ethanolamine as mentioned above or the catabolism of ascorbic acid and L-hydroxyproline (see Neuberger, 1981). Although the formation of glyoxylate from the cleavage of isocitrate by isocitrate lyase occurs in bacteria and plants, this reaction is not generally thought to take place in animals. However, this reaction has been reported to be present in pigeon and rat liver mitochondria especially during low energy states (Kondrashova and Radionova, 1971). The conversion of glyoxylate to glycine is unlikely to make a quantitative important contribution to the synthesis of glycine (see Neuberger, 1981).

1.6. METABOLISM OF AMINO ACIDS IN RUMINANT AND NON-RUMINANT MUSCLE

Whilst it is beyond the scope of this thesis to discuss in detail the comparative aspects of metabolism in ruminants and non-ruminants, some of the differences recorded in the amino acid metabolism in muscle of ruminants and non-ruminants will be mentioned. The catabolism of branched-chain amino acids (BCAAs) in ruminant muscle occurs at a much lower rate than in non-ruminant muscle (Coward and Buttery, 1982). However, in diabetes there is a marked increase in the oxidation of BCAAs in sheep muscle (Lindsay and Buttery, 1980). In rat diaphragm the oxidation of leucine is also known to increase in diabetes (Buse et al., 1976) but the effect is much less than is observed in ruminant muscle (see Lindsay and Buttery, 1980). The pattern of release of amino acids from muscles of different species (Table 1) shows that besides differences in BCAAs efflux between ruminants and non-ruminants, some are observed for alanine, glutamine and glycine (for most other amino acids, their fractional output is almost similar). Differences even appear to exist between two non-ruminants, rat and human, though firm conclusions are difficult to draw because of the different lengths of fasting used. In ruminant muscle alanine output is not linked to the catabolism of BCAAs to the same extent as in non-ruminant species (Lindsay and Buttery, 1980). In addition, about 5% of alanine-C is derived from glucose in ruminant muscle (Coward and Buttery, 1982) as compared to about

30% in the non-ruminant (Odessey *et al.*, 1974; Grubb, 1976). Similarly, the metabolism of amino acids in other organs of ruminants and non-ruminants differs in many respects (Lindsay, 1978,1980; Bergman and Heitmann, 1978). These differences appear mainly due to dissimilarities in the digestive physiology of the two groups. Due to the fermentative action of the rumen the profile of nutrients it supplies to the organs in ruminants will differ from that supplied to non-ruminants. For example, in non-ruminants β -hydroxybutyrate is utilised as an energy source in dietary energy insufficiency as a result of fat mobilisation. In ruminants, β -hydroxybutyrate is derived from butyrate in the rumen wall even during dietary sufficiency (Pennington, 1952). Non-ruminants receive a large amount of glucose from the diet, and their muscle has the capacity to oxidise it as a major fuel (Berger *et al.*, 1975). On the other hand, ruminants receive very little glucose from dietary sources, and about 90% of circulating glucose is synthesised in the body (Lindsay, 1978). Moreover glucose is poorly utilised by ruminant muscle (Coward and Buttery, 1982). Ruminant muscle meets its energy requirements from acetate, ketones (β -hydroxybutyrate being the major ketone used) and free fatty acids (Jarret *et al.*, 1976). Acetoacetate also appears to be an important energy fuel for ruminant muscle (Coward and Buttery,1982).

Thus it can be concluded that amino acid metabolism of ruminants may differ from that of non-ruminants and the data obtained from non-ruminant muscle should only be extrapolated to ruminants with caution.

1.7. ISOLATED PERFUSED MUSCLE PREPARATIONS

Perfusion has been defined as the maintenance of an organ in a viable state, isolated from the animal, by means of mechanically assisted circulation of an artificial medium through its vascular bed (Ross, 1972). The importance of perfusion techniques in studying biochemical mechanisms has long been recognised (Skutul, 1908) but early workers found consistent and reproducible preparations difficult to accomplish. As a result, research advances were most successful using other *in vitro* methods such as the tissue slices and homogenates. However, in recent years, more careful definition and control of the perfusion conditions has resulted in organ preparations that are reproducible. Isolated perfused muscle preparations afford several advantages over other *in vitro* systems, for example:

1. The muscle fibers are intact and substrates and hormones are carried to the cells through the normal physiological channels.
2. The normal functions of the organ can be reproduced and by control of the physiological conditions and perfusate composition, it is possible to study nutrient requirements, metabolite transport, intermediary metabolism and metabolic regulation.
3. The membrane barriers, compartmental division of the tissue and integration of pathways are maintained.
4. The viability of the muscle cell can be monitored.

5. The tissue can be quickly frozen at the end of an experiment with minimal changes in the intracellular levels of metabolites.

6. The effects of hormones and substrates on the function and metabolism of the tissue can be readily determined.

7. The rate of metabolism of the perfused preparations is usually close to that expected *in vivo*.

There is however a loss of nervous control, and especially in a recirculating perfusion system there is a build-up of metabolic end products. Also, the cost of perfusion apparatus, perfusion medium and monitoring devices are potential limitations to perfusion experiments. In spite of some of these disadvantages perfused muscle preparations are widely used (see section 4.1.). The procedure adopted in this study for the preparation of isolated rat hind-limb was based on that described by Ruderman *et al.* (1971) but modified in this laboratory (Ward, 1976; Ward and Buttery, 1979) (for modifications see section 4.1.). For ruminant muscle, the perfused sheep diaphragm developed in this laboratory was used (Coward, 1978; Coward and Buttery, 1980). Perfusion of the sheep hind-limb is possible (Cross *et al.*, 1974); however, it requires destruction of the carcass. A large quantity of perfusion medium is required, which is expensive. Also large quantity of perfusion medium makes tracer experiments expensive. Furthermore, the method is time consuming and subject to the problem of getting sufficient replication of data. For these reasons and also because of the cost, the method of Coward and Buttery (1980) was preferred. The perfusion of sheep diaphragm can be

carried out with 125-150 ml of perfusion medium. In addition, the diaphragm is composed largely of muscle, is of ideal size and can be readily excised and cannulated. The rest of the carcass then can be used for human consumption.

1.8. PERFUSION WITH ERYTHROCYTE-FREE MEDIUM

The perfusion medium for the sheep diaphragm preparation (Coward and Buttery, 1980) consisted of bovine serum albumin, Krebs-Henseleit bicarbonate buffer, erythrocytes and energy generating substrates. There are some disadvantages of using erythrocytes in the medium e.g. need to account for erythrocyte metabolism and haemolysis during the perfusion. Running 'blank' experiments, i.e. circulation of erythrocyte-containing medium through the apparatus without a sheep diaphragm can help making this correction, but they ignore the effects of organ on the chemical reactions between the erythrocytes and the other constituents of the perfusion medium. The need to collect sheep blood makes the preparation more complicated, time consuming and expensive. In addition estimation of the total gas exchange is more complicated. Thus one of the objectives of the present study was to examine the viability of the perfused sheep diaphragm using erythrocyte-free perfusion medium. Two possible approaches were considered : i) the use of fluorocarbon emulsions and, ii) the use of a medium free of erythrocytes but containing bovine serum albumin, Krebs buffer and energy generating substrates which is passed through the organ at a high flow rate. The first approach

was not used as flouorocarbons are very expensive and, although it has been used successfully for liver perfusions by a number of workers (Goodman et al., 1973; Triner et al., 1970), they suggested further investigations on the effect of fluOrocarbons on liver functions. Furthermore, possible disadvantages of flouorocarbons are that they may get oxidised by the microsomal cytochrome P-450 system (Ullrich and Diehl, 1971) and could be retained indefinitely by the organs (Clark et al., 1974; Riess and Le Blanc, 1982). Keeping this in view a study was carried out to find whether the diaphragm can be maintained in a viable state by passing the erythrocyte-free medium at a high flow rate through it. A similar approach has already been used for rat hind-limb perfusion and was found to be successful (Strohfeldt et al., 1974; Reimer et al., 1975).

The erythrocyte-free medium would also be used in the present study, for the rat hind-limb perfusions using radiochemicals, in order to eliminate any possible effects of erythrocyte metabolism.

1.9. OBJECTIVES OF THE CURRENT STUDY

From the information discussed in the previous sections it is evident that virtually nothing is known about the origin of glycine in muscle, in spite of a large efflux of glycine from muscle and its vital role in the animal body. The main objective of the present study was to know the origin of glycine in muscle. The metabolism of amino acids in non-ruminant muscle may differ from that of ruminant

muscle (see section 1.6.). Attempts were therefore made to study the origin of glycine both from non-ruminant and ruminant muscle. Emphasis was given to study the glycine synthesis from serine and threonine as these appeared to be quantitative important sources of glycine in animal body (see section 1.5.). In addition, it is important to quote Neuberger (1981) here, "A very important question which is still unresolved is, how far the glycine cleavage system is used for the synthesis of glycine". The importance of this system in glycine synthesis was investigated both in non-ruminant and ruminant muscle. The synthesis of glycine in rat muscle in anabolic conditions was also studied. It was hoped that this information would provide a better insight into the physiological significance of the glycine released by muscle.

MATERIALS AND METHODS

2.1. MATERIALS

Analytical grade reagents were used wherever possible. Reagents were mainly purchased from BDH Ltd., Poole, Dorset; Fisons Ltd., Loughborough; Koch-Light Laboratories, Colnbrook, Bucks and Sigma Chemical Co. Ltd., Surrey. Chemicals whose origin is particularly worthy of note are mentioned below.

Amino acids were purchased from Sigma Chemical Co. Ltd., Surrey; BDH Ltd., Poole or Koch-Light Lab. Ltd., Bucks.

Heparin was purchased from Boots Drugs Co., Nottingham.

ATP, ADP, phosphocreatine, pyruvate, all test combination kits, phosphoglycerate kinase, creatine kinase, glyceraldehyde-3-phosphodehydrogenase were obtained from Boehringer Corporation (London) Ltd., Lewes, East Sussex.

Sodium pentobarbitone was bought as the commercial preparation 'Nembutal' (60 mg/ml) from Abbot Lab. Ltd., Queenborough, Kent or 'Sagatal' (60 mg/ml) from May and Baker Ltd., Dagenham.

Bovine serum albumin (fraction V) was obtained from Armour Pharmaceuticals, Eastbourne.

Tetrahydrofolate, 5-formyl tetrahydrofolate, chloramine T DL- β -hydroxybutyrate, Triton X-100, NADPH, testosterone

propionate, 5,5'-dithiobis-(2-nitrobenzoic acid), reduced and oxidised glutathione, branched chain keto acids and pyridoxal 5'-phosphate were purchased from Sigma Chemical Co. Ltd., Surrey.

Ion exchange resins were purchased from Bio-Rad Laboratories Ltd., Bromley, Kent.

Trenbolone acetate (solid) was a gift from Roussel-Uclaf, France.

Penicillin and Streptomycin were purchased as sterile solutions from Flow Laboratories, Scotland or GIBCO Ltd., U.K.

Radiochemicals used in the study were purchased from Radiochemical Centre, Amersham, Bucks and were described as 96-99% pure. Purity of (U- 14 C)serine and (3- 14 C)serine was confirmed by split-stream amino acid analysis followed by counting of the serine fractions.

Scintillant as 'Fiso Fluor 1' or 'Optiphase X' was purchased from Fison Ltd., Loughborough.

Glass oxygenators for the perfusion apparatus were specially made by Fisons Ltd., Loughborough.

Millipore filter and filter holders were obtained from Millipore U.K. Ltd., London.

2.2. EXPERIMENTAL ANIMALS AND HOUSING

2.2.a. Rats

Specific-pathogen-free male and female rats of the Wistar strain were obtained from the Joint Animal Breeding Unit, University of Nottingham. The rats were kept in plastic rodent cages and maintained in a 12 h light and dark cycle (0600-1800). The temperature of the animal house was kept at 22°C. The rats were allowed free access to a standard rat diet (Table 2) and water.

2.2.b. Sheep

Suffolk and Suffolk cross fatstock lambs were normally bought from Nottingham or Derby livestock markets. They were kept on a standard diet (Table 3) for at least a week before slaughter. They were also fed a small quantity of hay, and water was available *ad libitum*.

2.2.c. Trenbolone acetate and testosterone experiments

Ten days prior to the commencement of the injection period, female rats weighing 80-85 g were randomly distributed to cages (2 rats per cage). The rats were allowed free access to a standard diet (Table 2) and water. The body weight of rats on the day injections were started was approximately 115 g. Daily, rats were injected subcutaneously via the neck skin fold with trenbolone acetate or testosterone (0.1 ml each) prepared in corn oil (described below). Control rats were injected with corn oil

Table 2. Composition of standard rat diet

<u>Ingredient</u>	<u>Composition (g/Kg)</u>
Ground wheat	450
Ground oats	268
Dried skimmed milk	25
Fish meal (Provimi 66)	150
Vitamin supplement	4.5
Mineral mix	9.7
Fat (tallow)	50
Salt	4.5
Cod liver oil	4.5
Berkonite	8.8

Table 3. Composition of sheep diet

<u>Ingredient</u>	<u>Composition (g/Kg)</u>
Oats	450
Barley	225
Grass meal	200
Nutramol 30 ¹	100
Vitamin/mineral supplement ²	25

1 F. Wright (Feed Supplements) Ltd., Ashbourne, Derby

2 Rumenco Ltd., Burton on Trent

(0.1 ml/rat). After 14 days of injection the rats were sacrificed by decapitation. Liver, diaphragm and hind-limb muscle were excised (within 1-2 min of decapitation) and immediately frozen in liquid nitrogen.

Both trenbolone acetate and testosterone propionate were dissolved in corn oil by adding the solid hormones to corn oil and keeping them on a stirrer in cold room for 24 h. The concentrations of trenbolone acetate and testosterone in corn oil were 1.15 mg/ml and 1 mg/ml respectively.

2.3. DETERMINATION OF RADIOISOTOPES

Radioactivity was determined by liquid scintillation counting using an Intertechnique liquid scintillation counter (model SL 30) (Intertechnique Ltd., Portslade, Sussex). Samples were counted for 10 min in glass scintillation vials or in disposable scintillation vial inserts (Hughes and Hughes Ltd., Essex, England) using a xylene based scintillant (Fiso Fluor 1, Fisons Ltd., Loughborough). All samples were kept at about 3 °C for at least 12 h prior to counting in order to minimise chemiluminescence. The external standard channels ratio method was used for efficiency correction. Ra²²⁶ was used as external standard source.

2.4. STATISTICS

Results were expressed as mean value of the data \pm the standard error of the mean (Mean \pm SEM, n) where n was the

number of replicates.

The comparisons of two means were done by Student's 't' test and analysis of variance was used for comparing more than two means. The significance of the difference was expressed at three levels of probability 5, 1 and 0.1% ($P < 0.05, 0.01$ and 0.001 respectively). Non-significance in all statistical analysis was assumed to be greater than 5% probability.

2.5. THE RAT HIND-LIMB PERFUSION SYSTEM

2.5.a. Perfusion apparatus

The perfusion apparatus (Fig. 3) was based on the procedure described by Ruderman et al. (1971) for the perfusion of isolated rat hind-limb. The apparatus was housed in a Perspex cabinet of dimensions 1500mm x 600mm x 1900mm (length x breadth x height). The air in the chamber was circulated continuously during perfusion and was kept at 40°C by a thermostat, the probe of which was placed near the muscle. This air temperature maintained the circulating medium at 37°C, which was monitored by a thermometer fitted into the oxygenator via a ground glass joint. The temperature difference was due to cooling of the medium as it passed through the pumps which were kept outside the cabinet. The pumps were kept outside the cabinet as they had the maximum recommended working temperature of 30°C. An even temperature in the cabinet was maintained by circulating air with a standard hair dryer (Haartrockner 855; Griffin and

Fig. 3. Diagram of perfusion apparatus

- A - Magnetic stirrer
- B - Reservoir
- C - Filter
- D - Peristaltic pump
- E - pH electrode chamber
- F - Oxygenator
- G - Thermometer
- H - Peristaltic pump
- I - Hg manometer
- J - Perspex tray supporting the isolated hind-limb
- K - Isolated rat hind-limb
- L - Screw clip
- M - Gas flow gauge
- N,O - Bottles containing distilled water

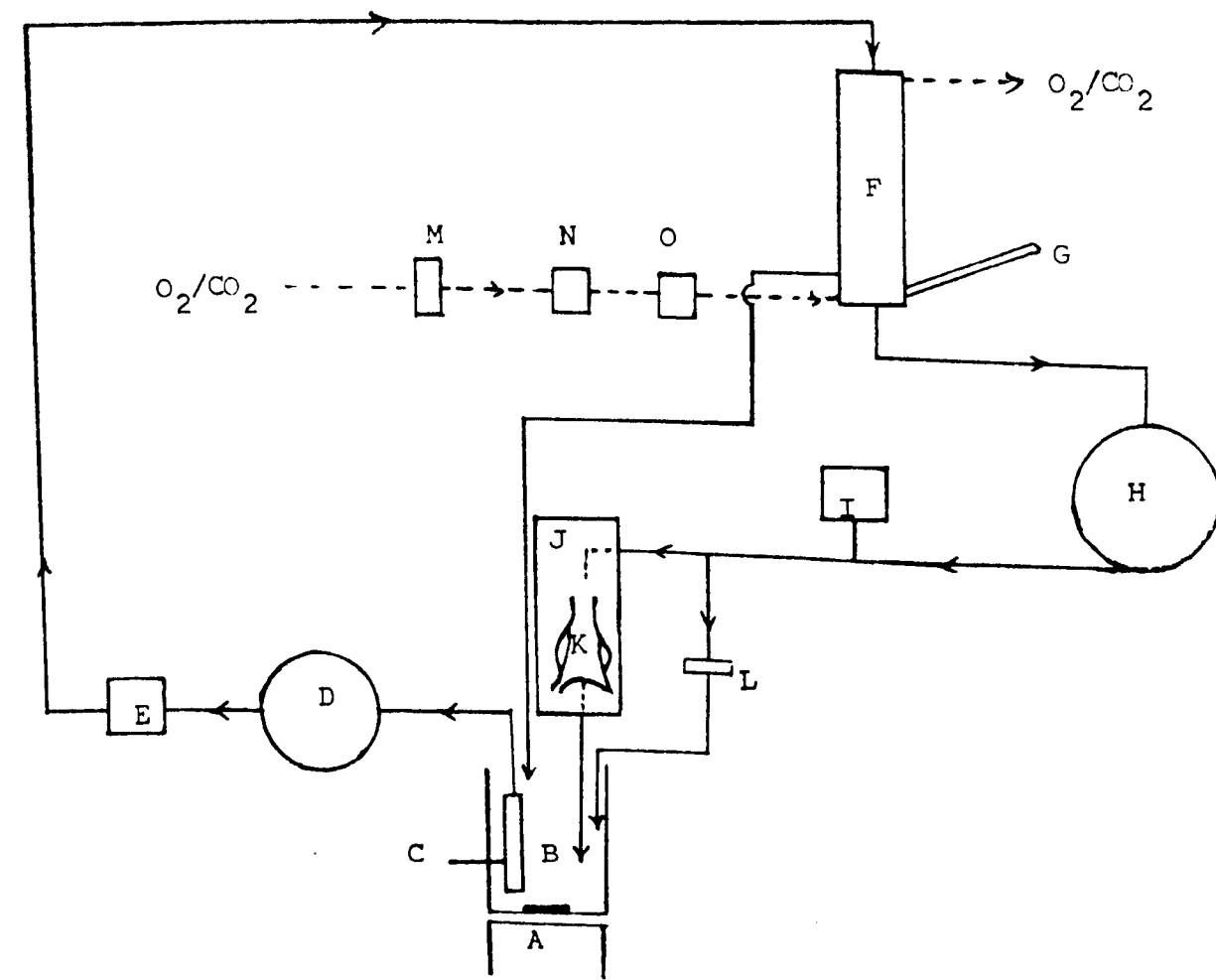

George Ltd., London). Two petri dishes containing water were placed in the cabinet for humidifying the air.

The isolated hind-limb was supported on a Perspex tray fitted at a slight angle. The reservoir was a graduated glass cylinder (100 ml) fitted with a 3-hole rubber bung. Through these holes passed the collecting funnel, the outlet for pumping medium from the reservoir and the outflow from the oxygenator. The medium was continuously mixed by a small magnetic stirrer and a glass-covered follower. It was pumped from the reservoir through a filter unit by a peristaltic pump (Type MHRE / 200; Watson-Marlow Ltd., Falmouth, Cornwall). The filter unit consisted of a disposable blood transfusion set. The medium was pumped to a multibulb oxygenator. Care was taken to spread the medium to the maximum surface of the oxygenator, so that maximum oxygen was absorbed by the medium. A combined glass electrode was inserted into the medium between the pump and the oxygenator to monitor the pH of the medium. A 10 ml plastic syringe barrel with the outlet sealed was used as the electrode holder.

The medium was equilibrated with humidified O_2 - CO_2 (95:5) which entered the oxygenator at a rate of about 300 ml/min (Ruderman *et al.*, 1971), as monitored by a gas flow gauge (Meterate GPE, Hemel Hempstead, Herts). The medium flowed from top to bottom whereas the gas passed from bottom to top. The O_2 - CO_2 (95:5) was humidified by passing through two bottles in a series containing distilled water. This also helped to heat up the oxygen before it entered the oxygenator. The medium from the oxygenator was pumped into

the isolated hind-limb by a second peristaltic pump. The arterial pressure was controlled by means of a screw clip on the tubing which connected the aortic cannula to the oxygenator overflow. A flow rate from the isolated hind-limb preparation of 0.33 ml/min/g muscle at a pressure of 8-9 cm of Hg was obtained by adjusting the screw clip and the arterial pump. This flow rate was found to oxygenate the muscle preparation optimally (Ruderman et al., 1980). Perfusion pressure was monitored by a mercury manometer connected by a side arm to the arterial tubing. Flow rate from the preparation was determined by measuring the volume of the medium collected in 1 min into a graduated cylinder (15-20 ml capacity). The medium was returned to the reservoir after determining the flow rate. Transparent, non-toxic, vinyl tubing of 3 mm internal diameter (I.D.) (NT/6; Portex Ltd., Hythe, Kent) was used for assembling the apparatus except in the peristaltic pumps. Here elastic grade, translucent tubing of 6 mm I.D. (12HE; Portex Ltd., Hythe, Kent) was used. Connectors were made of non-toxic plastic (Quickfit Instrumentation Ltd., Stone, Staffs) and 'T' pieces were made of glass (Elkay Ltd., Alton, Hants).

2.5.b. Perfusion medium

i) Composition of the medium

The Krebs-Henseleit bicarbonate buffer, pH 7.4 (Krebs and Henseleit, 1932) contained: bovine serum albumin, fraction V (BSA) (8%, w/v); washed rat erythrocytes (to give a final haematocrit of 10 ml cell volume in 100 ml perfusate); glucose (5.5 mM) and sodium pyruvate (0.15 mM).

In order to eliminate any possible effects of erythrocyte metabolism, perfusions using radiochemicals were carried out using an erythrocyte-free medium (Reimer et al., 1975). The composition of the erythrocyte-free medium was the same as mentioned above except that the BSA concentration was 4%.

ii) Preparation of the medium

The BSA was dissolved in Krebs-Henseleit buffer, adjusted to pH 7.4 with 1 M NaOH and passed through an AP 25 prefilter (Millipore (UK) Ltd., London) and a 0.22 μm pore size filter (Millipore (UK) Ltd.). Glucose and sodium pyruvate were dissolved in Krebs-Henseleit buffer to a concentration such that 1.0 ml was required for each perfusion. These were passed through a filter (0.22 μm pore size, Millipore (UK) Ltd.) into sterile containers and stored at -15°C for not longer than 2 weeks. The standard perfusion medium was prepared by adding 1.0 ml each of glucose and sodium pyruvate to approximately 50 ml buffer. To this was added 10 ml washed rat erythrocytes and the mixture was made to a final volume of 100 ml with the buffer. The pH of the medium was adjusted, if necessary, to 7.4 with 1M- NaHCO_3 (Thomas, 1973). The medium was freshly prepared. The medium used for each perfusion was 100-150 ml.

iii) Preparation of rat erythrocytes

Blood was collected in a heparinised beaker from male rats after decapitation. It was passed through glass wool, centrifuged for 5 min at $1000\times g$ and the plasma discarded. The cells were washed 3 times in 2 volumes of 0.9% NaCl. The

white cell layer was removed by aspiration at each wash step.

iv) Haematocrit

A blood sample was drawn into a narrow bore capacity tube and the end was sealed with plasticine. The capillary tubes were centrifuged at 1000xg for 20 min. The height of the packed red blood cell (A) and the total height of the packed cell volume and the plasma (B) was noted. Per cent haematocrit = $(A/B) \times 100$. For each blood sample haematocrit was determined in triplicate.

2.5.c. Surgical preparation of the isolated hind-limb

A male rat (170-184 g body weight) was anaesthetised by an intraperitoneal injection of aqueous sodium pentobarbitone (approx. 10 mg/100 g body weight). With the animal ventral side uppermost, an abdominal incision was made through the loose skin extending from the Xiphoid process to the pubic symphysis. The skin flaps thus formed were reflected to either side and the superficial epigastric vessels ligatured. Using an electrocautery (Model 708 SP65, Holborn Surgical Instrument Co. Ltd., London) a midline incision was made in the abdominal wall. The descending epigastric vessels were ligatured and the intestine moved to right of the animal. The intestine was wrapped in a warm (ca 37°C) 0.9% NaCl soaked tissue paper. A number of ligatures were made and tied (see Fig. 4a). The internal spermatic vessels (1) and hypogastric vessels were ligatured and testicles and contiguous adipose tissue were removed

using the electrocautery. Then the inferior mesenteric vessels (3) were ligatured and the two ligatures (4) were positioned and tied around the descending colon. The colon was excised between these ligatures and reflected anteriorly. The iliolumbar vessels (5), residual positions of the descending colon and genital systems were ligatured (6). A ligature was placed around the tail (7). Two pairs of loose ligatures were placed around the aorta and vena cava, one (8,9) just below the origin of the renal and spermatic vessels and the other (10,11) between the origin of the renal vessels. The position of these vessels varies widely between individual rats and it was sometimes necessary to ligature above the origins of the two iliolumbar vessels. The vena cava and aorta were then carefully separated using a blunted seeker. Cannulation was carried out as follows. The ligature (8) round the aorta was tied, occluding the aorta and introducing the anoxic period. The aorta was elevated slightly with a seeker and the aorta incised below the ligature (8) using fine scissors. A polythene catheter (I.D. 0.86 mm, O.D. 1.27 mm, length 30 cm Luer end, Intramedic, Clay-Adams Inc., N.York), whose tip had been cut obliquely and which was filled with 0.9% NaCl containing 200 I.U. heparin/ml, was introduced and pushed to a point midway between the iliolumbar vessels and the aortic bifurcation. It was learnt with experience that it is easier to introduce the catheter by keeping its sharp point upward rather than downward (Fig. 4b). When a catheter with its sharp point downward was introduced into the aorta, this increased the chances of its passing through the wall of the aorta.

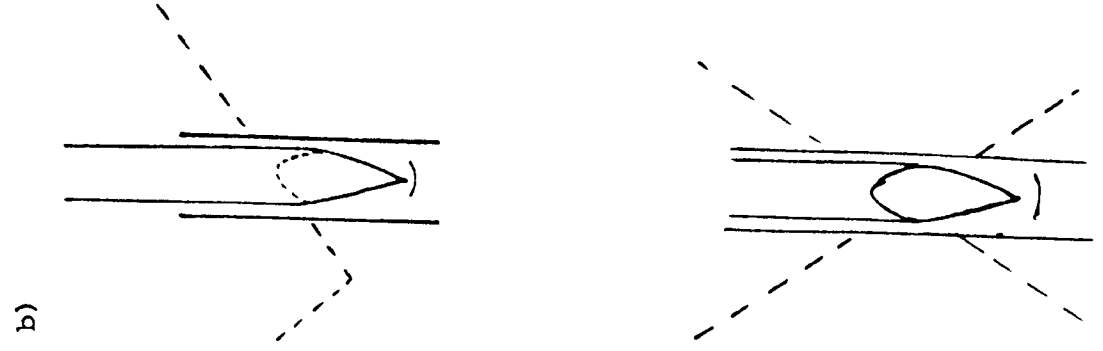
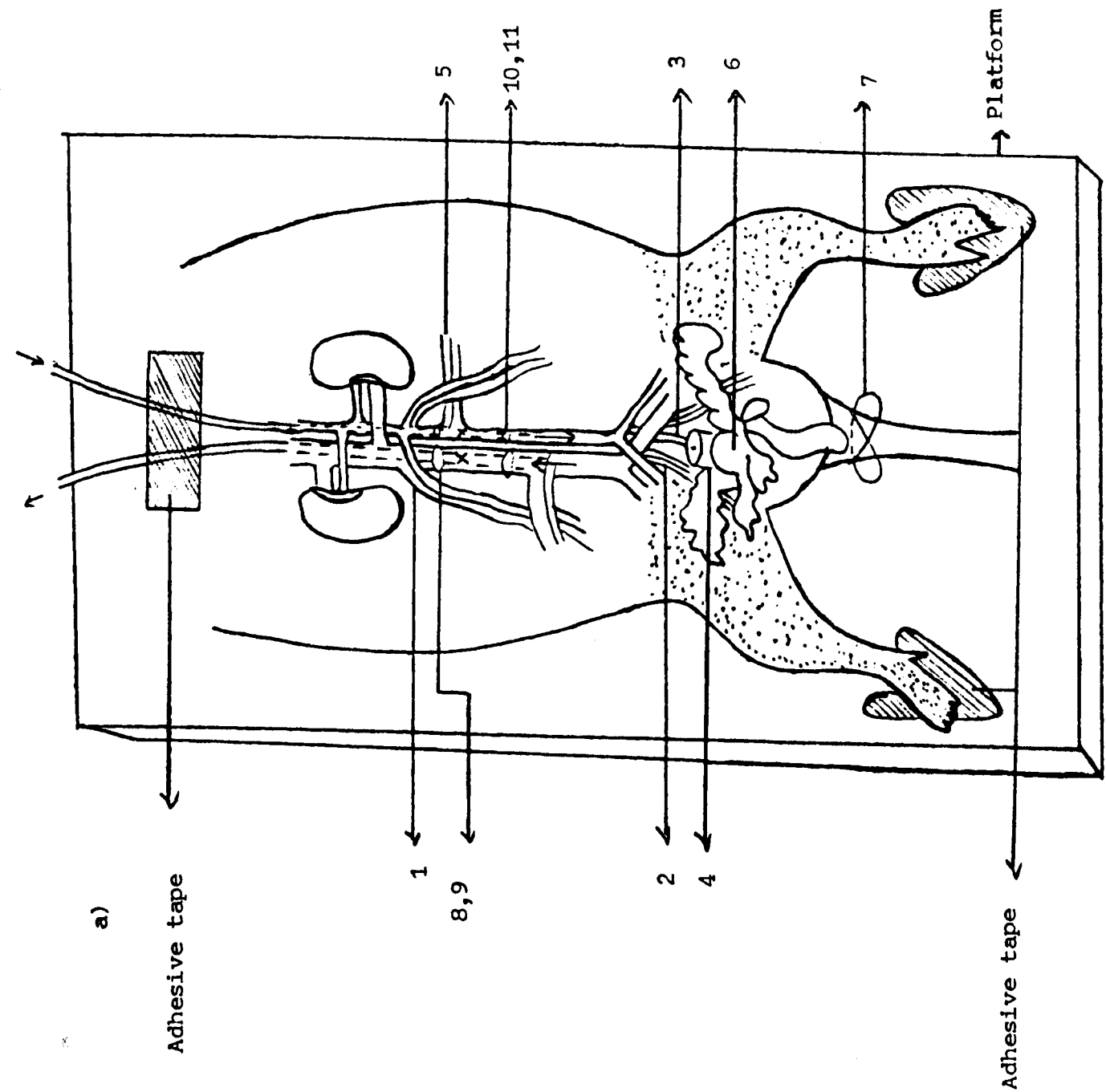

Fig. 4a. Vessels ligatured during the surgical preparation of isolated rat hind-limb

1. Internal spermatic vessels
2. Hypogastric vessels
3. Inferior mesenteric vessels
4. Colon
5. Iliolumbar vessels
6. Descending colon and urogenital system
7. Tail
- 8,9; 10,11. Aorta and vena cava
- x. The point at which the cannula was inserted

Fig. 4b. Entry of the catheter



Approximately 0.5 ml heparinised saline was injected from the syringe into the preparation to decrease the risk of intramuscular blood clotting. The catheter was tied in place (10).

The ligature (9) around the vena cava below the renal vessels was tied and cannulation performed by pushing a catheter through the vessel wall to a position level with the aortic cannula. Successful cannulation was indicated by immediate back flow of blood through the catheter. The catheter was tied in place. Approximately 5 ml of warmed (ca 37°C) heparinised saline was flushed through the preparation. The animal was quickly hemisected below the level of the renal vessels and the hind-limb preparation transferred to the tray. To avoid kinking of the aorta and vena cava the catheters were fixed to the tray using adhesive tape. Similarly, to avoid kinking of the hind-limb vessels the feet of the animal were extended on the tray and held in place with double sided adhesive tape. Kinking of the aorta, vena cava or hind-limb vessels can decrease the flow rate of the medium through the preparation.

The preparation was taken to the cabinet and connected to the arterial circulation. The perfusion medium was recirculated for at least 30 min prior to incorporation of the hind-limb into the system in order to equilibrate to 37°C. Care was taken not to allow air bubble to enter the cannula. The first 5 ml of the medium through the preparation was discarded and the venous outflow returned to

the reservoir via the funnel. The exposed surface of the preparation was moistened periodically with warm (ca 37°C) 0.9% NaCl during the perfusion. The catheters were reused after cleaning and sterilization with ethanol.

2.5.d. Cleaning and sterilization procedures

Immediately after each experiment all the glassware and silicone rubber tubing were dismantled and washed with water. The dismantled apparatus was then soaked for 12 h in a solution of detergent (approx. 0.5 g/l) (Pyroneg Diversey Ltd., Barnet, Herts) and then for 2 h in sodium hypochlorite (approximately 3 ml/l). The glassware was then rinsed thoroughly first with hot tap water and then with distilled water. The tubing was cleaned by passing a strong stream of hot tap water through it for about 5 min and then rinsed with distilled water. Prior to each experiment, the assembled apparatus was rinsed thoroughly with 2 changes of autoclaved saline, and then the perfusion medium was circulated. Tubing was routinely discarded after 4-5 experiments. The interior of the cabinet was cleaned and then swabbed with 'lysol' before each perfusion.

Saline, plastic centrifuge tubes used for centrifuging the rat erythrocytes were autoclaved at 120°C for 20 min. Glassware was oven sterilized at 160 °C for 2 h. The tray supporting the hind-limb was rinsed with ethanol.

2.6. THE SHEEP HEMIDIAPHRAGM PERFUSION SYSTEM

2.6.a. Perfusion apparatus

The perfusion apparatus was essentially the same as described earlier for the perfusion of rat hind-limb (section 2.5.a.). Some of the changes were as follows:

- 1) The air in the cabinet was maintained at approximately 41°C, which kept the temperature of circulating medium at 39°C.
- 2) The flow rate of 10-13 ml/min was obtained at a pressure of 8-9 cm Hg.
- 3) The diaphragm was rested on a slatted tray (Fig. 6a) in order to channel the effluent perfusate from both cut ends of the diaphragm into the funnel and then to the reservoir.

2.6.b. Perfusion medium

i) Composition:

Bovine serum albumin, fraction V	80 mg/ml
Glucose	4.64 μ mol/ml
Acetate	2.81 μ mol/ml
DL-3-hydroxybutyrate	1.32 μ mol/ml
Propionate	0.024 μ mol/ml
Butyrate	0.008 μ mol/ml
Penicillin	100 IU/ml
Streptomycin	100 IU/ml

These standard perfusion constituents were made up to

120-150 ml in Krebs-Henseleit bicarbonate buffer (KHBB), pH 7.4.

ii) Preparation: The preparation of the medium was essentially the same as described earlier for the rat hind-limb preparation (section 2.5.b.ii.) except that erythrocytes were absent.

2.6.c. Cannulation of diaphragm

A sheep was stunned with a humane electric stunner (92 V) (T.A Ashton Ltd., Sheffield, Yorks) and immediately a transverse incision of the neck was made, which almost simultaneously severs the trachea, oesophagus, common carotid arteries, jugular veins and spinal cord at the occipito-atlantal junction. This was done to prevent 'blood splash' (Kirton et al., 1978). Then the sheep was hung (head downwards) and a mid-line longitudinal incision was made. The rumen-reticulum, intestines, gall bladder, spleen and liver were removed. The diaphragm (Fig. 5) was taken out by cutting around its periphery, as close to the body wall as possible, with a knife. The diaphragm was placed, thoracic surface upwards on a piece of aluminium foil kept on a hot water bottle, the temperature of which was about 39°C - 41°C. A small cut was made at the dorsal and ventral edges of the right crus (*Crus dextrum*) of the lumbar portion of the diaphragm (*Pars lumbalis*) to allow medium to flow through the preparation (when the diaphragm is placed thoracic surface upward, the right crus is on left hand side). An incision was made in the phrenic vein at the

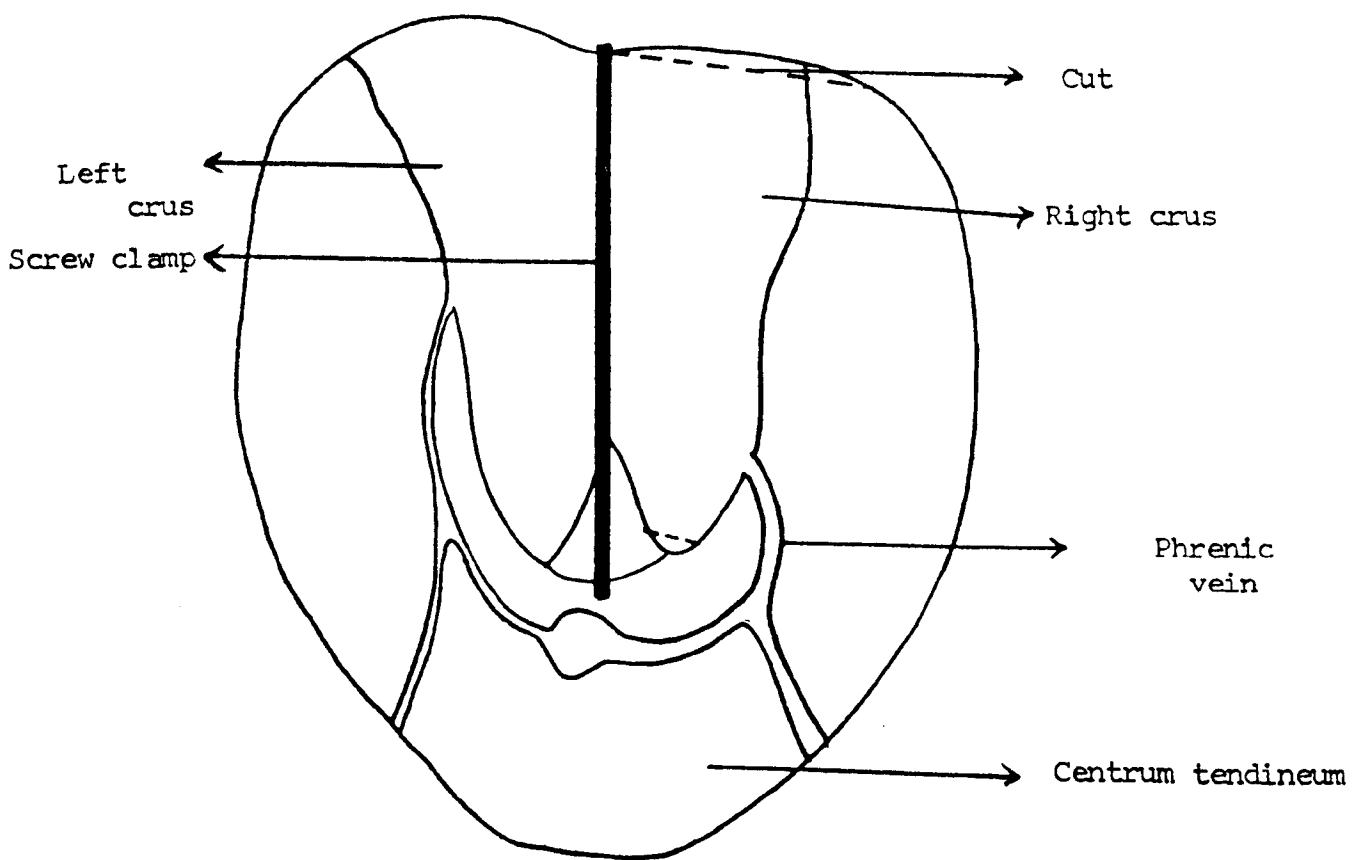

Fig. 5 Diagram of the sheep diaphragm

lowest possible point with a scalpel (blade 10b). Care was taken at this point not to use too much pressure on the scalpel, otherwise the incision could pass through the phrenic vein. (This generally happened initially but once practice was gained it rarely occurred.). If it happened, another incision was tried 2-4 mm above the previous one. A polythene catheter (I.D. 10 mm, length 15-20 cm; Portex Ltd., Hythe, Kent) attached to 10 ml syringe and filled with oxygenated and heparinised KHBB (maintained at approx. 39°C) was inserted at the incision. Care was taken that the catheter was filled to the tip with medium in order to avoid any air bubbles entering the preparation. About 20 ml medium was flushed through the preparation to remove most of erythrocytes present. The catheter was secured at the place with 2-3 stitches. The diaphragm, after cannulation, was wrapped in warm aluminium foil and rapidly transferred to the laboratory for connection to the perfusion apparatus. Care was taken to prevent the tip of the cannula damaging the vein during transportation. Careful transportation and use of a cannula with smooth edges both decreased the chances of damaging the preparation. The diaphragm was removed from the foil, placed on the slatted tray and was connected to the apparatus 5-7 min after stunning the sheep. The perfusate pressure was checked immediately and adjusted to 8-9 cm Hg. Initial high perfusion pressure could disrupt the vein. The right crus was clamped off from the left crus by a large clamp (Fig. 6b) which was placed along the central tendinous matter. This enabled the perfusion medium

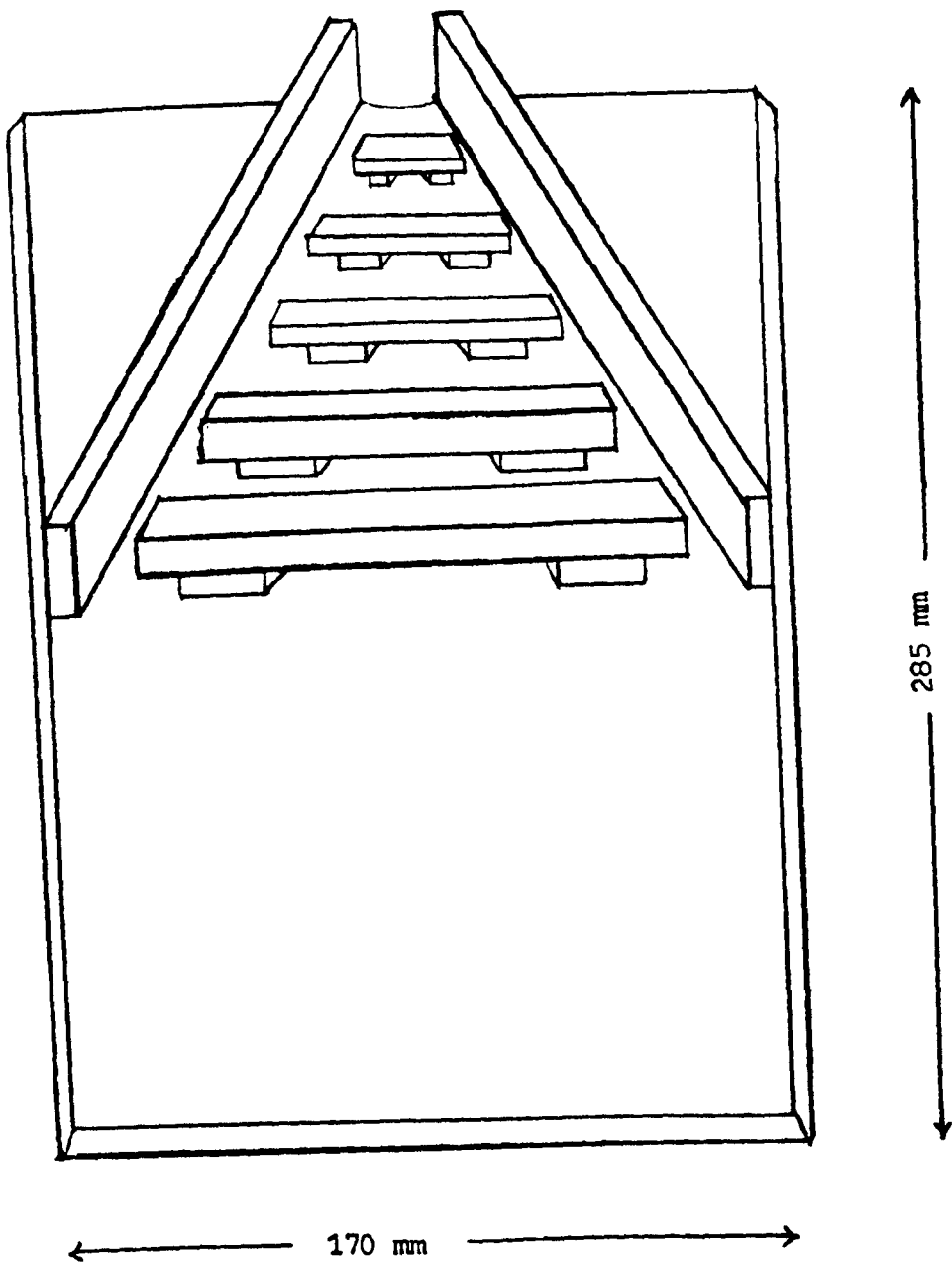

Fig. 6a Diagram of the tray

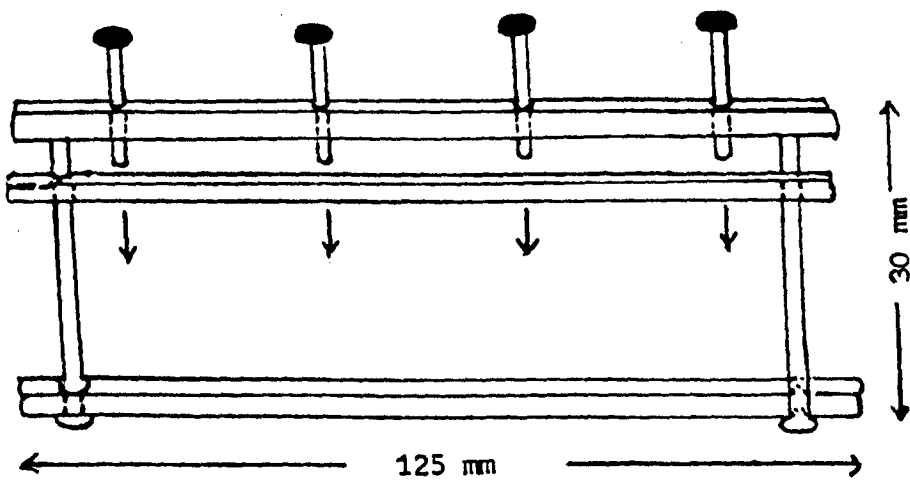

Fig. 6b Diagram of the screwclamp

not to enter the left crus, which was not perfused. The exposed surface of the diaphragm was covered with polythene to minimise desiccation. The polythene allowed inspection of the organ during perfusion.

2.6.d. Cleaning and sterilization of apparatus

The apparatus was cleaned and sterilized as described (section 2.5.d.).

2.7. ADDITION OF RADIOCHEMICALS

Radiochemicals were added to the perfusion medium 5-7 min after the connection of isolated muscle to the apparatus. Within this time it was generally known whether the perfusion of muscle would be satisfactory or not. To obtain an estimate of the initial specific activity of the chemical under test a sample of the perfusate was taken 10 min later.

2.8. SAMPLING PROCEDURES

2.8.a. Perfusate

Samples were taken from the bottom of the oxygenator via the thermometer outlet. The initial sample was collected 10 min after connection of the muscle. Whole perfusate was removed directly into ice-cold picric acid (1%, w/v). The changes in volume of the perfusate resulting from withdrawal

of the samples and from drying was monitored from the graduated reservoir and it was used in the relevant calculations.

2.8.b. Muscle

Muscle samples were taken at the end of the perfusion period. While the perfusion continued, muscle samples were quickly excised, placed in a polythene bag and dropped into liquid nitrogen. The tissue was ground, weighed and then either used immediately for analysis or stored at -15°C until analysed. To obtain samples representative of the *in vivo* situation, the muscle samples were taken from anaesthetised rats; from sheep the muscle samples were taken immediately after slaughter.

2.9. CRITERIA TO TEST PERFUSION VIABILITY

2.9.a. Potassium concentration

i) Perfusate

Potassium in the perfusate plasma was determined by flame photometry. Sodium concentration in the plasma is about 16 times that of potassium and it was necessary to add sodium to the potassium standard used for making a calibration curve, as Na^+ interferes with the assay. The samples of the perfusate plasma were diluted 1:50 (v/v) with a solution of NaCl (8.7 g/l deionised water) (Domingo and Klyne, 1949). The potassium content of the samples was then read on an EEL flame photometer (Evans Electroselenium Ltd., Halsted, Essex). The potassium content was determined with

reference to a linear calibration curve obtained by using 0 - 0.3 mmol potassium/l of a solution (8.7 ^{NaCl} g/l deionised water). The curve deviated from straight line at a concentration of potassium > 0.3 mmol/l of the solution. The NaCl solution (8.7 g/l deionised water) was used as a blank to adjust the absorbance to 0, and 0.3 mmol potassium/l of the solution was used to adjust the absorbance to 100.

ii) Muscle

Muscle (0.2 g) was taken in a centrifuge tube and homogenised with ice-cold 0.87% NaCl. It was filtered and volume made to 100 ml with 0.87% NaCl. An aliquot was taken for K⁺ estimation.

2.9.b. Muscle water content

The water content of the perfused muscle was determined in order to know the extent of oedema due to the uptake of fluid by the muscle. After the perfusion, a sample of muscle was excised, kept between the folds of tissue paper and placed in a pre-weighed container. The container and the contents were reweighed. The sample was dried to constant weight at 110°C. The same procedure was adopted for fresh muscle samples obtained from unperfused rat hind-limb or sheep diaphragm.

2.9.c. Muscle extracellular space

The determination of extracellular space of the muscle samples was based on the observation of Creese and Northover (1961) that inulin is not taken up by muscle cells to any

substantial extent. The inulin space, i.e. that volume of tissue water necessary to contain the inulin at its concentration in the plasma, was calculated.

Inulin space (ml/g wet muscle)

$$= (\text{dpm/g wet muscle}) / (\text{dpm/ml plasma})$$

The perfusions were carried out using (^3H)inulin in the medium. (^3H)Inulin was determined in the perfused muscle and the perfusate plasma at the end of the perfusion.

2.9.d. Perfusate lactate concentration

The method of Hohorst (1962) was used for the determination of lactate.

Lactate dehydrogenase, LDH (EC 1.1.1.27) catalyses the conversion of lactate to pyruvate in the presence of NAD^+ which is reduced to NADH. The equilibrium of this reaction is towards the reactants but can be pushed forward by an excess of NAD^+ and the trapping of the pyruvate formed as a hydrazone. The reaction is followed by measuring the increase in extinction at 340 nm.

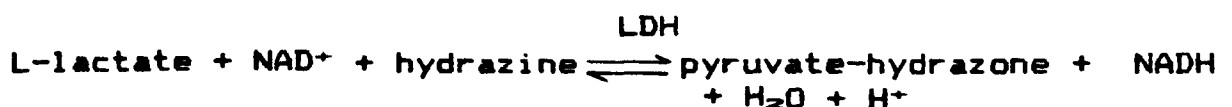

To one volume of the perfusate plasma (0.2 ml) was added two volumes of ice-cold perchloric acid (0.6 M). The mixture was kept in ice for 30 min, centrifuged at about $1000\times g$ for 10 min and the supernatant collected. Supernatant (0.2 ml) was taken for determination of lactate; the 'zero

time' sample was used undiluted whereas from 3 h was diluted 7 times with distilled water. The determinations were done using the 'Biochemica Test Combination' (Boehringer Corporation Ltd., Lewes, E. Sussex). Lactate concentration in the supernatant was determined by using the following formula.

$$\mu\text{mol/ml sample} = (\Delta E \times V) / (\epsilon \times d \times v)$$

(Bergmeyer et al., 1974)

Where ΔE is change in extinction; V , assay volume (ml); v , volume of sample used in assay (ml); d , light path (cm) and ϵ is the extinction coefficient ($\text{cm}^2/\mu\text{mol}$). The ϵ for NADH at 340 nm is $6.22 \text{ cm}^2/\mu\text{mol}$. The recovery of added lactate was found to be satisfactory.

μmol lactate

Sample	Added	Sample+Added	% Recovery
(A)	(B)	(C)	$[(C-A)/B] \times 100$
1.18	2.50	3.65	98.80

2.9.e. Perfusate pyruvate concentration

The method of Czok and Lamprecht (1974) was used for the assay.

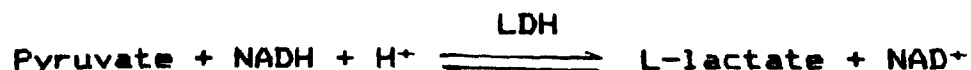

The equilibrium of this reaction is towards right, so when a suitable quantity of NADH is present in the assay mixture, the reaction proceeds quantitatively. The reaction is followed by measuring the decrease in extinction at 340 nm. The formula mentioned above for the lactate determination was used for measuring the sample pyruvate.

Samples were deproteinised immediately after removal from the apparatus to stop the action of any LDH present. An aliquot (2.0 ml) of the perfusate was mixed with 4.0 ml of ice-cold perchloric acid (0.6 M), kept on ice for 30 min and centrifuged to collect the supernatant. Two millilitres of this supernatant was mixed with 0.7 ml tripotassium phosphate (0.7 M) to bring the pH to near neutral. The mixture was kept on ice for 15 min and centrifuged at 1000xg for 5 min. An aliquot (1.0 ml) was taken and pyruvate estimated using the 'Biochemica Test Combination' (Boehringer Corporation Ltd.) by adding 0.1 ml each of NADH and lactate dehydrogenase. The recovery of added pyruvate was satisfactory.

µmol pyruvate

Sample	Added	Sample+Added	% Recovery
(A)	(B)	(C)	$[(C-A)/B] \times 100$
0111	0.250	0.345	93.60

2.9.f. Muscle ATP, ADP and AMP estimation

i) Sample preparation

Samples of muscle from the rapidly frozen tissues were used for the estimation of ATP, ADP and AMP. Muscle (approx. 1 g) was placed in an ice-cold plastic centrifuge tube containing ice-cold 6.0 ml perchloric acid (0.6 M) and homogenised using a tissue homogeniser (Polytron) for a total of 3 min at full speed (6 x 30 sec burst followed by 30 sec rest). After homogenisation it was centrifuged at 1000xg for 10 min. The supernatant was collected for the estimation of ATP, ADP and AMP.

ii) ATP determination

The method of Jaworek *et al.* (1974a) was used for the determination of ATP. 3-Phosphokinase (PGK) (ATP:3-phosphoglycerate-1-phosphotransferase (EC 2.7.2.3) catalyses the phosphorylation of glycerate-3-phosphate by ATP to glycerate - 1 - 3- diphosphate (reaction I) which is reduced by glyceraldehyde - 3 - phosphate dehydrogenase (GAPDH) (glyceraldehyde - 3 - phosphate : NAD⁺ oxidoreductase (EC 1.2.1.12) and NADH (reaction II). The equilibrium of reaction I is towards left while that of reaction II is towards right. However, the addition of excess glycerate -3- phosphate and the removal of glycerate-1-3-diphosphate by reaction II moves the overall equilibrium towards complete conversion of ATP to ADP. The reaction equilibrium is further pushed towards right by the removal of glyceraldehyde-3-phosphate by the action of triose-phosphate isomerase (TIM) (D-glyceraldehyde-3-phosphate keto isomerase (EC 5.3.1.1) (reaction III), and reduction of dihydroxyacetone phosphate formed to glycerol-1-phosphate by glycerophosphate dehydrogenase (GDH) (L-glycerol-3-phosphate : NAD⁺ oxido reductase; EC 1.1.99.5) and NADH (reaction IV).

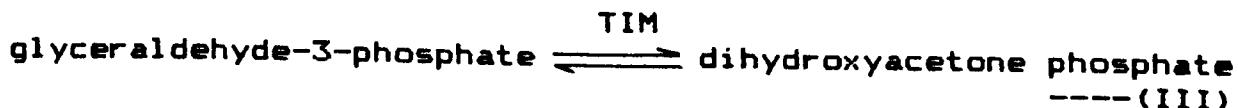
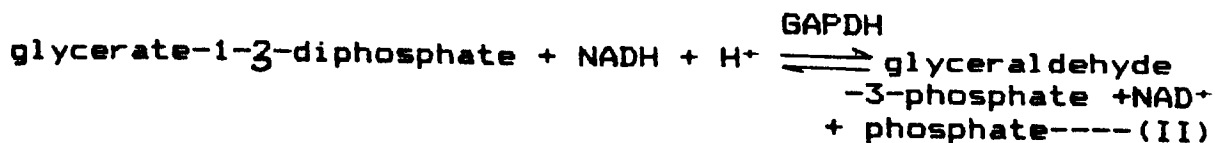
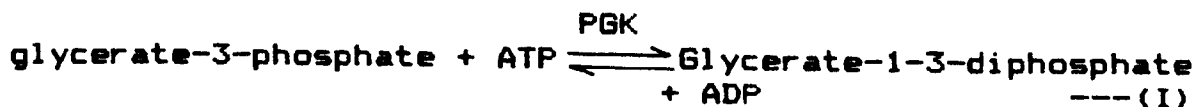

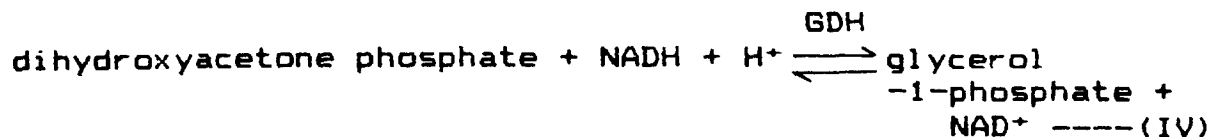

For each mole of ATP present, two moles of NADH are oxidised to NAD⁺. The reaction is followed by the decrease in the absorbance at 340 nm.

An aliquot (0.2 ml) of the supernatant prepared from the muscle (described above) was used for the assay using the 'Biochemica ATP Test Combination' (Boehringer Corporation Ltd.). The ATP concentration in the supernatant was calculated by using the following formula.

$$\mu\text{mol/ml sample} = (\Delta E \times V) / (v \times d \times \epsilon)$$

(Bergmeyer et al., 1974)

Where ΔE is change in extinction; V , assay volume (ml); v , volume of the sample used in the assay (ml); d , light path in cm and ϵ extinction coefficient ($\text{cm}^2/\mu\text{mol}$). The extinction coefficient for NADH at 340 nm is $6.22 \text{ cm}^2/\mu\text{mol}$. Recovery of added ATP to the muscle samples is shown below; it was found to be satisfactory.

sample	<u>$\mu\text{mol ATP}$</u>		% recovery
	Added ATP	Sample+added ATP	
(A)	(B)	(C)	$[(C-A)/B] \times 100$
0.26	1.00	1.23	97.0

iii) ADP and AMP determinations

ADP and AMP were estimated by the method of Jaworek et al. (1974b) in a single assay system. Pyruvate kinase (PK) (ATP : pyruvate phosphotransferase; EC 2.7.1.40) catalyses

the phosphorylation of ADP to ATP by phosphoenol pyruvate.



The pyruvate formed is reduced to lactate by the enzyme lactate dehydrogenase (LDH) (EC 1.1.1.27). This is accompanied by the oxidation of NADH to NAD⁺. The reaction is followed by the decrease in absorbance at 340 nm.

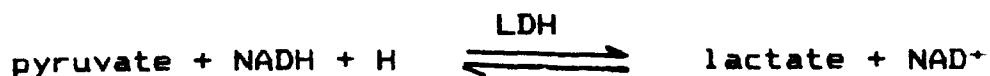

The equilibrium of the above reactions favours the formation of products.

The AMP in the sample is converted into ADP by myokinase (MK) (EC 2.7.4.3) which is estimated as above.

An aliquot (2.0 ml) of the supernatant prepared from muscle (mentioned above) was neutralised by the addition of 0.4 ml triethanol buffer (pH 7.6, 0.5 M) containing K₂CO₃ at a concentration of 0.2 M. It was centrifuged and supernatant collected. An aliquot (1.0 ml) of the supernatant was mixed in a cuvette with 1.0 ml distilled water and assayed by the 'Biochemica ADP/AMP Test Combination'. The ADP and AMP concentrations were calculated using the formula mentioned above for the ATP concentration. The recovery of added ADP from muscle samples was satisfactory.

<u> μmol ADP </u>			
sample	Added ADP	Sample+added ADP	% recovery
(A)	(B)	(C)	[(C-A)/B]x100
0.199	0.50	0.709	102.0

2.9.g. Muscle pyruvate and lactate estimation

i) Preparation of sample

Same as for ATP, ADP and AMP estimation.

ii) Pyruvate determination

The principle of the method has been described above for the perfusate pyruvate estimation. An aliquot (2.0 ml) of deproteinised extract was neutralised with 1.0 ml K_3PO_4 (0.7 M), kept on ice for 10 min, centrifuged at 1000xg for 10 min and supernatant collected. One millilitre supernatant was mixed with 1.0 ml distilled water in a cuvette and the estimation was carried out using the 'Biochemica Pyruvate Test Combination'. Pyruvate concentration in supernatant was calculated as described previously for the perfusate. The recovery of added pyruvate using the method was satisfactory.

<u>μmol pyruvate</u>			
Sample pyruvate (A)	Added pyruvate (B)	Sample + Added (C)	% Recovery [(C-A)/B]x100
0.0284	0.050	0.0744	92.00

iii) Lactate determination

The principle of the method used has already been described (see perfusate lactate determination). An aliquot (0.2 ml) of deproteinised extract was measured into a cuvette and the assay performed as mentioned previously for the perfusate lactate determination. Recovery of added

lactate in muscle samples was satisfactory.

<u>μmol lactate</u>			
Sample lactate	Added lactate	Sample+added	% Recovery
(A)	(B)	(C)	$[(C-A)/B] \times 100$
4.42	5.00	9.30	97.60

2.9.h. Glycogen determination

The method of Roehrig and Allred (1974) was used for glycogen determination in muscle. Muscle (1 g) was homogenised in 5.0 ml ice-cold perchloric acid (0.6 M) using a homogeniser (Polytron) for a total of 2 min (4 x 30 sec burst followed by 30 sec rest) at full speed. An aliquot (50 μl) of homogenate was mixed with 25 μl KHCO₃ (10%, w/v), 0.5 ml acetate buffer (pH 4.8, 0.2 M) and 50 μl of amyloglucosidase (EC 3.2.1.3) (20 mg/2 ml, 14 U/mg protein). It was incubated for 2 h with shaking at 40°C. A blank lacking the enzyme was also incubated. After 2 h of incubation the reaction was stopped by adding 0.25 ml HClO₄ (0.6 M). Samples were neutralised by the addition of 0.2 ml K₃PO₄ (0.7 M) and centrifuged to collect the supernatant. An aliquot (0.2 ml) of the supernatant from both the blank and the test incubations was used for estimation of glucose using the 'Biochemica Glucose Test Combination'. The glycogen concentration was determined by subtracting the value of the blank from the test value. The amounts of glycogen were expressed as mg glucose equivalent.

The method yielded a quantitative recovery of glucose.

Sample glycogen	Added glycogen	$\frac{\text{mg}}{\text{A}}$ glycogen (as / glucose)		% Recovery
		Sample	added	
(A)	(B)	(C)		$[(C-A)/B] \times 100$
4.20	2.50	6.52		92.80

The above enzymatic method has also been used for the estimation of muscle glycogen in a number of other studies (Reimer *et al.*, 1975; Djovkar *et al.*, 1983; Crouse *et al.*, 1984).

2.9.i. Measurement of oxygen uptake by sheep diaphragm

Oxygen measurements were made using a Clark oxygen electrode (Rank Bros., Bottisham, Camb.). A potential difference is applied across the electrodes, as a result of which oxygen is reduced at the cathode (platinum) by electrons generated at the anode (silver). A voltage difference of 0.6 V is maintained. At this voltage difference, current generated is proportional to oxygen concentration of the medium.

i) Calibration of the electrode

The meter was zeroed and then 100% deflection was adjusted for distilled water saturated with 100% oxygen. The electrode was calibrated by using distilled water at 39°C which was saturated with air (distilled water kept stirred for 15-20 min at 39°C; oxygen content 0.212 $\mu\text{mol/ml}$, Kielley (1969)).

ii) Measurement of oxygen concentration of 'arterial' and 'venous' perfusate

A sample (ca 2 ml) of the 'arterial' perfusate was taken in a syringe from the oxygenator via the thermometer outlet. It was transferred to the closed chamber of the equipment containing the electrode and a fine magnet serving as a stirrer. The deflection was recorded. Care was taken whilst taking the sample of the 'venous' perfusate as there was no 'venous' cannula in the preparation. The millipore filter holder (one-half) was fixed onto the syringe and sample of the 'venous' perfusate was taken into the syringe by touching the holder to the preparation nearest to the point from where the perfusion medium flowed out of the preparation. This was done to minimise the exchange of oxygen of the 'venous' perfusate with atmosphere. The sample was transferred to the electrode chamber and deflection recorded. Other precautions included constant stirring, and a minimising the free space in the electrode chamber so as to avoid any exchange of oxygen.

The rate of oxygen consumption was calculated from the arteriovenous difference for oxygen and the flow rate of the perfusate.

Rate of oxygen consumption ($\mu\text{mol}/\text{min}/\text{g}$ muscle) = [(oxygen conc. of 'arterial' perfusate - oxygen concn. of 'venous' perfusate) x flow rate] / [weight of perfused muscle (g)]

The oxygen concentration of the 'arterial' and the 'venous' perfusate is expressed in $\mu\text{mol}/\text{ml}$ and the flow rate in ml/min .

2.9.j. Determination of muscle creatine phosphate

i) Preparation of sample

Same as for ATP, ADP and AMP estimation.

ii) Principle

Creatine phosphate was determined by the method reported by Lamprecht et al. (1974). The principle of the method involves transfer of phosphate from creatine phosphate to ADP by the enzyme creatine kinase. The resulting ATP phosphorylates D-glycerate-3-phosphate to 1,3-diphosphoglycerate in the presence of phosphoglycerate kinase. Finally, 1,3-diphosphoglycerate undergoes NADH-dependent reduction with glyceraldehyde-3-phosphate dehydrogenase to D-glyceraldehyde-3-phosphate. One mole of NADH is oxidised per mole of creatine phosphate. The decrease in extinction at 340 nm is recorded.

iii) Reagents

- | | |
|---|---------------------|
| 1. Buffer/glycerate-3-P
triethanolamine buffer | 0.5 mole/l (pH 7.6) |
| MgSO ₄ | 4 mmole/l |
| glycerate-3-phosphate | 6 mmole/l |
| 2. NADH | 2.5 mmole/l |
| 3. ADP | 10 mM |
| 4. Glutathione (GSH) | 50 mM |
| 5. Phosphoglycerate kinase (PGK) (\geq 400 U/mg) | |

6. Creatine kinase (CK) (≥ 18 U/mg), dissolved 5 mg in 1 ml distilled water
7. Glyceraldehyde - 3 - phosphate dehydrogenase (GAPDH) (≥ 36 U/mg)

iv) Assay system

Buffer 1	2.0 ml
NADH	0.4 ml
GSH	0.2 ml
ADP	0.03 ml
PGK	0.015 ml
GAPDH	0.015 ml
Deproteinised extract	0.2 ml

The above were mixed and the extinction measured after 15 min (E_1). CK (0.01 ml) was added, the reagents mixed and after 15 min the extinction was again measured (E_2).

$$E_1 - E_2 = \Delta E$$

The creatine phosphate in the supernatant was calculated by using the formula:

$$\mu\text{mol/ml sample} = (\Delta E \times V) / (v \times d \times \epsilon)$$

(Bergmeyer et al., 1974)

Where E , V , v , d and ϵ are the same as described earlier (section 2.9.f.ii.). The recovery of added creatine phosphate was satisfactory.

<u>μmol creatine phosphate(CP)</u>			
Sample	Added CP	Sample+added CP	% Recovery
(A)	(B)	(C)	$[(C-A)/B] \times 100$
0.68	1.00	1.64	96.00

2.10. DETERMINATION OF WEIGHT OF MUSCLE PERFUSED

2.10.a. Rat hind-limb

An exhaustive study in this laboratory by Ward (1976) has shown that perfused muscle represents 17% of the donor rat's body weight, which agrees well with the value of 16.6% reported by Ruderman et al. (1971).

2.10.b. Sheep diaphragm

The weight of perfused muscle was determined at the end of the perfusion. The weight of the muscle samples taken for analysis were added to the weight of remaining perfused muscle. The latter was determined after carefully cutting the right crus from the unperfused left crus and all non-muscle tissues (which included connective tissue and occasionally very small fragments (< 200 mg) of liver attached to the connective tissue).

2.11. GLUTATHIONE DETERMINATION

2.11.a. Reduced glutathione (GSH)

i) Principle

GSH in erythrocytes and muscle was determined by using Ellman's reagent (5,5'-dithiobis-(2-nitrobenzoic acid, DTNB) (Ellman, 1959; Sedlak and Lindsay, 1968; Beutler et al., 1963). The principle of the method involves reduction of Ellman's reagent to 2-nitro-5-mercaptobenzoic acid which has an intense yellow colour, by SH groups.

ii) Reagents

1. Tris buffer (pH 8.9, 0.4 M)
2. DTNB (0.1 M in methanol)
3. Reduced glutathione (2×10^{-3} M)
4. Trichloroacetic acid, TCA (50%, w/v)
5. 0.02 M ethylenediaminetetracetic acid (EDTA)

iii) Procedure

a) Muscle

About 800 mg muscle was homogenised at 4°C for a total time of 3 min (6 x 30 sec burst followed by 30 sec rest) in 8 ml of 0.02 M EDTA using a Polytron homogeniser. An aliquot of 5.0 ml homogenate was mixed with 4.0 ml distilled water and 1.0 ml TCA solution. After standing on ice for about 40 min it was centrifuged at 1000xg for 10 min. To 2.0 ml of the supernatant was added 3.5 ml Tris buffer (pH 8.9, 0.4 M) and 0.1 ml DTNB. The absorbance was read within 5 min at 412 nm against a reagent blank with no homogenate.

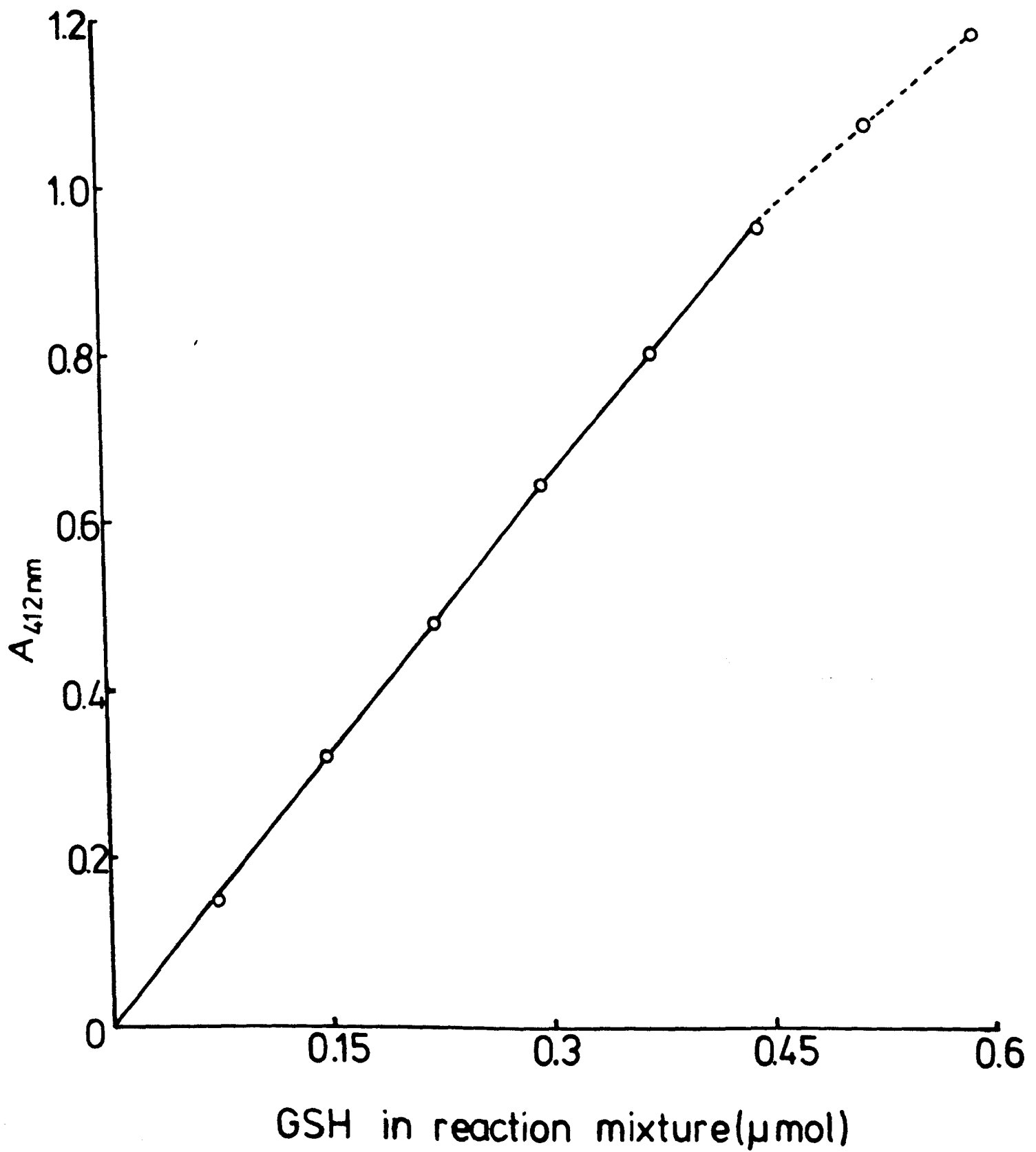

Fig. 7 The calibration curve for determination of reduced glutathione

b) Erythrocytes

Two millilitres of the whole perfusate was centrifuged at 1000xg for 10 min, and supernatant discarded. The erythrocytes collected were washed twice with 0.9% NaCl and centrifuged. The volume was made 2.0 ml and to it was added 0.4 ml TCA (50%, w/v). It was kept on ice for 10-15 min and centrifuged to collect the supernatant. To 0.5 ml of this supernatant was added 1.5 ml distilled water, 4.0 ml Tris buffer (pH 8.9) and 0.1 ml DTNB. The extinction was read at 412 nm within 5 min.

The calibration curve obtained with reduced glutathione is shown in Fig. 7. A molar extinction coefficient of 13200 was obtained, which is in accordance with the earlier reported value (13603) (Beutler et al., 1963).

The recoveries of reduced glutathione added to both muscle and erythrocytes were satisfactory, as shown below.

<u>μmol GSH (muscle)</u>			
Sample	Added GSH	Sample+added GSH	% Recovery
(A)	(B)	(C)	$[(C-A)/B] \times 100$
0.114	0.50	0.614	100.00
0.152	0.50	0.650	99.60
0.148	0.50	0.640	98.40

<u>μmol GSH (erythrocytes)</u>			
Sample	Added GSH	Sample+added GSH	% Recovery
(A)	(B)	(C)	$[(C-A)/B] \times 100$
0.319	0.50	0.818	99.80
0.319	0.50	0.825	101.20

This method measures total sulfhydryl groups but is often taken as a measure of reduced glutathione (Hardig and Hoglund, 1983; Takashashi, 1983; Griffith and Meister, 1979; Speisky *et al.*, 1985) as over 90% of the non-protein thiol compounds in tissues are in the form of GSH (Long *et al.*, 1961).

2.11.b. Oxidised glutathione (GSSG)

GSSG in erythrocytes and muscle was measured using the method described by Bernt and Bergmeyer (1974).

i) Principle



GSSG is measured from the rate of change of extinction at 340 nm.

ii) Reagents

1. Tripotassium phosphate, $\text{K}_3\text{PO}_4 \cdot 3\text{H}_2\text{O}$ (1.75 M)
2. Egg albumin (ca 1%, w/v)
3. NADPH (10 mg NADPH- Na_4 in 1 ml 1% NaHCO_3)

4. Glutathione reductase (GR) from yeast ≥ 120 U/mg (1 mg protein/ml)
5. Perchloric acid (ca 1.0 M)

Whole perfusate (5.0 ml) taken before and after the perfusion were centrifuged at 1000xg for 10 min to collect erythrocytes. The erythrocytes were washed twice with 0.9% NaCl and centrifuged. The volume was made 5.0 ml with distilled water and to it was added 5.0 ml of 1 M perchloric acid. Samples were kept on ice for 15 min and supernatant collected after centrifugation. To 4.0 ml of the supernatant was added 0.4 ml K_3PO_4 (1.75 M) and the mixture centrifuged to collect the supernatant. The supernatant had pH 7.0.

Muscle samples (ca 0.5 g) taken before and after the perfusion were homogenised in 8.0 ml deionised water. Aliquots (5.0 ml) were deproteinised and neutralised as described above.

iii) Assay conditions were: wavelength, 340 nm; light path, 1 cm; cuvettes, silica; temperature, room temperature. Measurements were taken against air.

The following were pipetted into cuvettes : ml

Sample(deproteinised,neutralised)	1.50
Distilled water	1.60
Albumin solution	0.15
NADPH	0.10

After mixing the extinction was read at 340 nm(E_1).

GR suspension (0.01 ml) was added. Reagents were mixed and the extinction read at 8, 10, 12, 14 and 16 min. The extinction E_2 was determined by extrapolation to the time of GR addition. $E_1 - E_2 = \Delta E_{\text{GSSG}}$

iv) Calculations

The extinction coefficient of NADPH at 340 nm is 6.22 $\text{cm}^2/\mu\text{mol}$.

$$\mu\text{mol GSSG in assay mixture} = (\Delta E_{\text{GSSG}} \times \text{Vol of assay mixture}) / 6.22$$

The recoveries of added GSSG both in muscle and erythrocytes were satisfactory (99.6 % and 96.7 % respectively).

2.12. AMINO ACID ANALYSIS

2.12.a. Plasma and whole perfusate amino acids

The plasma and whole perfusate amino acids were determined by the method of Stein and Moore (1954). One volume of plasma or whole perfusate was mixed with 5 volumes of picric acid (1%, w/v). Nor-leucine was added as an internal standard. The mixture was kept on ice for 1 h and then centrifuged at 1000xg for 10 min. The supernatant was passed down a previously prepared column of anion exchanger (Dowex AG 2x8, Cl' form, 200-400 mesh) at a flow rate of approximately 1 ml/min. The precipitate was resuspended in 3 volumes of picric acid (1%, w/v) and after standing at 0°C for 30 min it was centrifuged as above. The supernatant was

Table 4. Recoveries of amino acids from perfusate

Amino acids	<u>μmol amino acid/ml</u>		% Recovery $\frac{(B-A) \times 100}{0.25}$
	Sample (A)	Sample plus added amino acid (B)	
Asp	0.055	0.307	100.8
	0.064	0.310	98.4
Thr	0.041	0.286	98.0
	0.046	0.295	99.6
Ser	0.052	0.308	102.4
	0.061	0.309	99.2
Glu	0.066	0.318	100.8
	0.081	0.341	104.0
Gln	0.018	0.264	98.4
	0.017	0.272	102.0
Gly	0.062	0.307	98
	0.07	0.314	97.6
Ala	0.048	0.299	100.4
	0.054	0.303	99.6
Val	0.031	0.312	112.4
	0.035	0.283	99.2
Met	0.009	0.239	92.0
	0.006	0.239	93.2
Ile	0.023	0.268	98.0
	0.027	0.272	98.0
Leu	0.042	0.289	98.8
	0.043	0.297	101.6
Tyr	0.023	0.285	104.8
	0.022	0.275	101.2

--contd

Table 4. Recoveries of amino acids from perfusate

Amino acids	<u>μmol amino acid/ml</u>		% Recovery $\frac{(B-A) \times 100}{0.25}$
	Sample (A)	Sample plus added amino acid (B)	
Phe	0.025	0.284	103.6
	0.027	0.276	99.6
Lys	0.073	0.314	96.3
	0.085	0.328	97.2
His	0.024	0.273	99.6
	0.025	0.278	101.2
Arg	0.0397	0.291	100.5
	0.0408	0.285	97.7
Pro	0.018	0.263	98.0
	0.024	0.265	96.4

Amino acids (0.25 μmol/ml) were added to samples

passed down the resin column. This procedure of washing the precipitate was repeated, and then the column was washed with a further 3 volumes of picric acid solution. Finally, 10 ml of 0.02 M HCl was passed down the column. The column effluents were pooled and evaporated to dryness under reduced pressure using a rotary evaporator at 37°C. The residue was washed twice with approximately 10 ml distilled water and reduced to dryness using a rotary evaporator. The final residue was redissolved in distilled water, passed through a filter (0.45 μ m pore size, Millipore) and stored at -15°C prior to amino acid analysis. The amino acids were determined on Locarte (Mark 4A) or LKB 4400 amino acid analysers. Recoveries of amino acids added to the whole perfusate prepared by this method were satisfactory (Table 4).

2.12.b. Preparation of the resin column

A suspension of resin (Dowex AG 2XB, Cl⁻ form, 200-400 mesh) was made in 1 M HCl and allowed to settle. The fine particles were removed after the resin had settled for about 10 min. The resin was poured into a glass column to form a resin bed, 30 mm x 10 mm supported by glass wool. The resin was washed with distilled water until the pH of effluent reached that of the distilled water.

2.12.c. Muscle intracellular fluid (free) amino acids

Muscle samples (0.8 g-1.0 g) were placed in a 50 ml plastic centrifuge tube containing ice-cold 10 ml picric

acid (1%, w/v) and 1.6 μ mol nor-leucine. The tissue was homogenised at about 4°C using a Polytron tissue homogeniser at full speed for a total time of 3 min (6 x 30 sec burst followed by 30 sec rest). The probe was washed clean with approximately 5 ml picric acid (1%, w/v). After standing in ice for 1 h, the homogenate and the washings were centrifuged at 1000xg for 10 min. The supernatant obtained was passed down the resin column. The precipitate was resuspended in 10 ml picric acid (1%, w/v), centrifuged as before, and the supernatant passed down the resin column. Finally, the column was washed with 10 ml picric acid (1%, w/v) and then with 10 ml of 0.02 M HCl. The column effluent was treated in a manner similar to that described previously (section 2.12.a.). The recoveries of added amino acids were satisfactory (Table 5).

2.12.d. Muscle protein-bound amino acids

Samples of muscle (approximately 1 g) were transferred to cooled 50 ml capacity plastic centrifuge tubes containing ice-cold 10 ml trichloroacetic acid (10%, w/v) (TCA). These were homogenised and centrifuged as described above (section 2.12.c.). The supernatant was discarded and the precipitate was resuspended in 10 ml ice-cold TCA and recentrifuged. This washing procedure was repeated a further 3 times. The final precipitate was dried to a constant weight at about 60°C and then stored at room temperature in a dessicator. Approximately 200 mg of the dried TCA precipitable protein was hydrolysed in 300 ml HCl (6 M)

Table 5. Recoveries of tissue intracellular free amino acids

Amino acid	<u>μmol amino acid/g muscle</u>			% Recovery $\frac{(C-A) \times 100}{B}$
	Sample (A)	Amino acid added (B)	Sample plus added amino acid (C)	
Asp	0.101	0.10	0.196	95.0
Thr	0.618	0.70	1.304	98.0
Ser	1.066	0.70	1.761	99.3
Glu	0.311	0.20	0.500	94.5
Gly	4.70	4.00	8.645	98.6
Ala	2.89	3.50	6.326	98.2
Val	0.192	0.20	0.387	97.5
Met	0.0111	0.05	0.0591	96.0
Ile	0.097	0.10	0.191	94.0
Leu	0.229	0.20	0.420	95.5
Tyr	0.089	0.10	0.187	98.0
Phe	0.071	0.10	0.169	98.0
Lys	0.942	1.0	1.960	101.8
His	0.133	0.20	0.330	98.5
Arg	0.428	0.40	0.819	97.8

A formulated amino acid mixture was added to the samples. The results were not corrected for extracellular contamination.

under reflux and N_2 gas at $110^\circ C$ for 22 h. The hydrolysate was made 500 ml with distilled water. To an aliquot of 5.0 ml was added $0.5 \mu\text{mol}$ nor-leucine. This was evaporated to dryness at about $37^\circ C$ under reduced pressure using a rotary evaporator. The residue after washing with distilled water as mentioned above (section 2.12.a.) was dissolved in distilled water. Before loading on amino acid analyser, it was passed through a filter ($0.45 \mu\text{m}$, Millipore).

The same procedure was adopted for the determination of amino acid composition of bovine serum albumin (fraction V).

2.12.e. Amino acid analysers

Quantitative amino acid analysis was performed by two automatic amino acid analysers : i) Locarte (Mark 4A) amino acid analyser (separation based on the system of Atkin and Ferdinand (1970) and, ii) LKB 4400 amino acid analyser (separation based on the system described by Andrews, 1981). Details of the operation for both the analysers are given in Table 6.

2.12.f. Internal standard

DL-Nor-leucine was used as an internal standard. A colour factor (a predetermined constant, obtained by running a standard amino acid mixture) was used to correct for differences in colour development with different amino acids. The area of amino acid peaks was determined by using integrators (Table 6).

Table 6. Details of amino acid analysers operation

	<u>Locarte</u>	<u>LKB</u>
Amino acids	Acidic and neutral	Acidic, neutral and basic
Column resin	LA-49	Aminex A9
Column Height (mm)	230	250
Column diameter (mm)	9	4.5
Buffer flow rate (ml/min)	0.5	0.33
Ninhydrin flow rate (ml/min)	0.5	0.33
Temperature of column °C	30	33 & 60
Buffers:		
Loading	pH 2.2, Li (0.3M)	pH 2.2, Li (0.3M)
1	pH 2.58, Li (0.28M)	pH 2.75, Li (0.2M)
2	pH 3.65, Li Li (0.3M)	pH 3.0, Li (0.3M)
3	-	pH 3.02, Li (0.6M)
4	-	pH 3.45, Li (1.0M)
5	-	pH 3.3, Li (1.6M)
Regeneration	LiOH (0.3M)	LiOH (0.3M)
Timings (min):		
Regeneration	20	6
Equilibration	80	40
Integrator used	Spectra- physics SP4100	Spectra- physics SP4270

2.13. INTRACELLULAR METABOLITE CONCENTRATION

The extracellular space of muscle was determined as described before (section 2.9.c.). The intracellular metabolite concentration was calculated using the following formula:

$$\begin{aligned} &\text{Intracellular metabolite concentration } (\mu\text{mol/g muscle}) \\ &= [\text{concn. of metabolite in} \\ &\quad \text{muscle}(\mu\text{mol/g muscle})] - \\ &\quad [(\text{concn. of metabolite in} \\ &\quad \text{final perfusate}(\mu\text{mol/ml}) \times \\ &\quad \text{inulin space}(\mu\text{mol/g muscle}))] \end{aligned}$$

The calculations are based on the assumption that the concentration of inulin or any metabolite in the extracellular space is equal to concentration of that metabolite in the perfusate plasma.

2.14. DETERMINATION OF ^{14}C AMINO ACID RADIOACTIVITY

2.14.a. Split-stream amino acid analyser

A split-stream amino acid analyser was constructed for the isolation, collection and determination of activity in amino acids. The Locarte (Mark 4A) amino acid analyser was used for the purpose. The split-stream device diverted 80% of the column eluant to the fraction collector to be taken for determination of its activity. The remainder of the eluant was diluted with distilled water and mixed with ninhydrin for colour development and subsequent quantitation (Fig. 8). Each fraction coming out of the analyser was

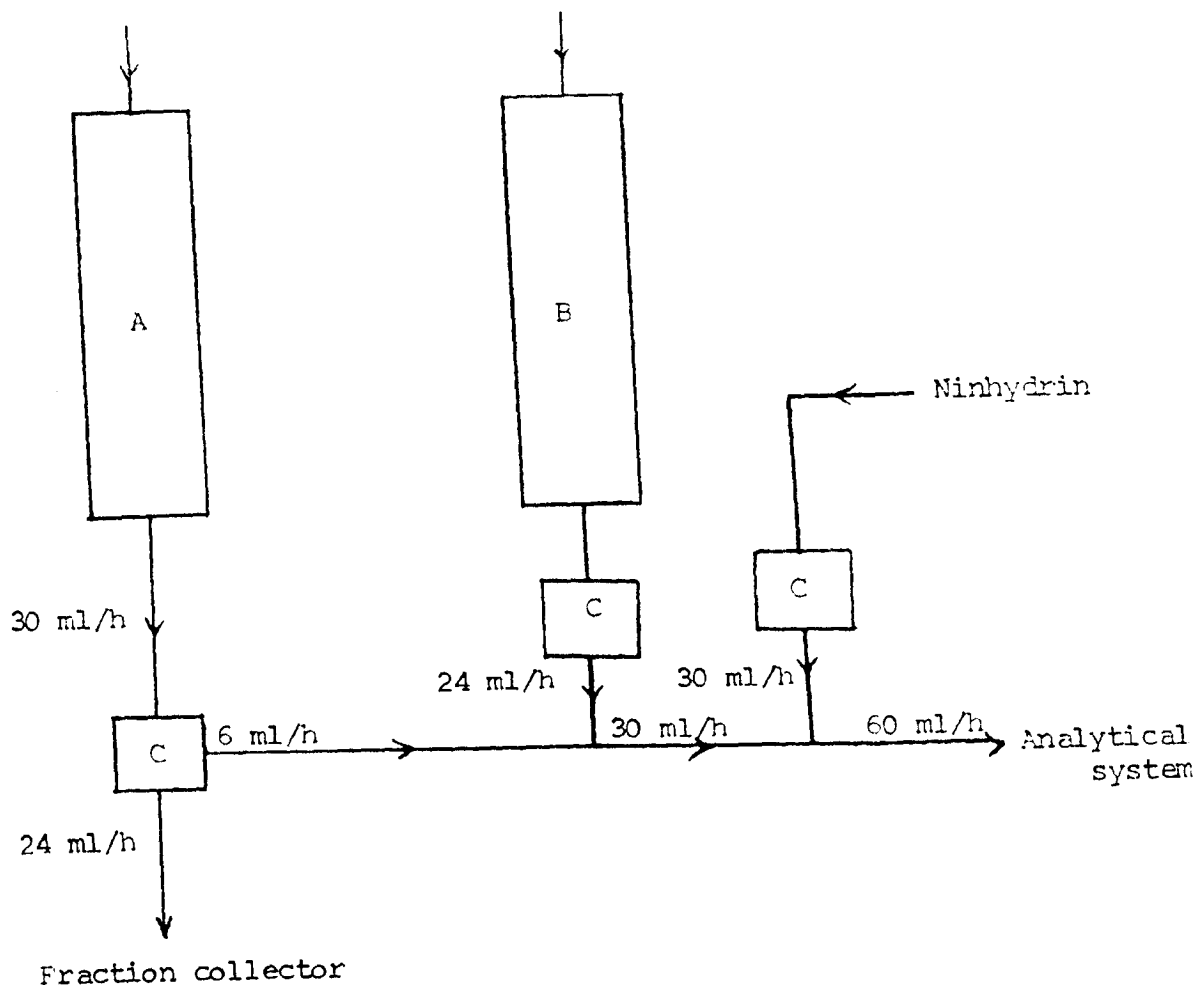

- A, Separating column
- B, Diluting column
- C, Peristaltic pump

Fig. 8 Diagram of split-stream amino acid analyser

collected for 1 min directly into scintillation vials kept in a fraction collector. The activity in each vial was determined by liquid scintillation counting. The validity of the procedure was verified by determining the recovery of ^{14}C -labelled amino acids : leucine, serine and glycine on the system. The recoveries of the activity from the system were determined by summing up the activity of each sample collected for the entire amino acid peak. The recoveries varied from 95-108%.

2.14.b. Matching of fractions collected to amino acid chromatograms

There was a time delay between when a particular amino acid was collected on the fraction collector and its corresponding position on the chromatogram. This time delay was determined using radioactive leucine. A time lag of 17 min was found. The collected fractions were identified on the chromatogram by taking into account a lag period of 17 min ('fraction number' + 17 = time on the chromatogram; reference point being start of the first buffer after regeneration and equilibration; 1 fraction was collected per min).

2.14.c. Sample preparation for split-stream analysis

i) Radioactivity in perfusate amino acids

For determination of radioactivity in asp, ser, glu, gln, gly and ala, 6.0 ml of 3 h perfusate (nor-leucine 1.2 μmol) was deproteinised and final volume made 2.0 ml

after passing through the resin column and drying (section 2.12.a.). One millilitre of it was loaded on the amino acid analyser. Perfusate met and cys radioactivities were determined by deproteinising 12 ml of 3 h perfusate (nor-leucine 0.16 μ mol) and making the final volume 2.0 ml. A sample (1.0 ml) was loaded on the analyser.

ii) Radioactivity in muscle free-amino acids

Muscle (1 g) was taken and homogenised in presence of picric acid and nor-leucine (1.6 μ mol), passed through the resin column and dried as described in section 2.12.c.. The final volume was made 2.0 ml. One millilitre of this was loaded on the analyser.

iii) Radioactivity in muscle-bound amino acids

Muscle samples were processed and hydrolysed as described in section 2.12.d.. An appropriate aliquot was taken for determination of radioactivity.

2.15. DETERMINATION OF SERINE HYDROXYMETHYLTRANSFERASE (EC 2.1.2.1) ACTIVITY

2.15.a. Organ removal and storage

The rats were killed by decapitation. The liver, diaphragm and hind-limb muscle were excised (within 1-2 min) and immediately frozen in liquid nitrogen. The liver, diaphragm and hind-limb muscle from sheep were removed after stunning and slaughtering as described earlier (sections 2.2.c. and 2.6.c.). These organs were removed within

1-3 min of stunning and immediately frozen in liquid nitrogen until required for the enzyme assay.

2.15.b. Preparation and storage of tetrahydrofolate

Tetrahydrofolate is oxidised rapidly in solution to dihydropteroylglutamic acid and so it was prepared and kept in an inert atmosphere. A 10 mM solution of L-tetrahydrofolate was prepared by dissolving it, at about 30°C in 75 mM phosphate buffer (pH 7.4) containing 60mM β -mercaptoethanol under nitrogen. The solution of tetrahydrofolate was dispensed into tubes (10 ml capacity tubes, 'Vacutainer'). Not more than 2 ml solution was dispensed per tube. The tubes were immediately stoppered and air in them was displaced with nitrogen. These tubes were stored at -40°C. The solution was used within 2 weeks.

2.15.c. Preparation of homogenates

The tissues were removed from liquid nitrogen, powdered immediately and weighed in a plastic centrifuge tube.

To the rat or sheep liver was added 9 volumes of ice-cold 50 mM phosphate buffer (pH 7.4) containing 0.25 M sucrose and 1 mM EDTA (homogenising buffer). The tissue was then homogenised with a Polytron tissue homogeniser at speed 3 for 45 sec with intermittent cooling. The homogenates were diluted with homogenising buffer to 1% (w/v) for the rat liver and 0.5% (w/v) for the sheep liver. Triton X-100 was added to the homogenates to give a final concentration of 0.1%.

Similarly, rat diaphragms were homogenised with 9 volumes of ice-cold homogenising buffer and sheep diaphragms with 4 volumes. Triton X-100 was added to give a final concentration of 0.1%. The Polytron tissue homogeniser was used at speed 3 for a total of 90 sec, with intermittent cooling. The homogenates were passed through a cotton gauge to remove any large particles present. The filtered homogenates (rat diaphragm, 10% w/v; sheep diaphragm, 20% w/v) were used for the enzyme assay.

The homogenates, 10% (w/v) and 20% (w/v) containing Triton X-100 at a final concentration of 0.1% were prepared for rat and sheep hind-limb muscle respectively. The method was similar to that described above for diaphragm.

(Intermittent cooling--- tissue was homogenised for 15 sec and then cooled for at least 1 min before the next homogenisation).

2.15.d. Enzyme assay

The method used for determination of serine hydroxymethyltransferase (SHMT) activity was that described by Snell (1980a) which is based on the method of Taylor and Weissbach (1965).

Principle: SHMT catalyses the reaction:



(3-¹⁴C)serine yields a radioactive C-1 unit in N⁵,N¹⁰-methylene tetrahydrofolate. This C-1 unit equilibrates immediately with the carrier formaldehyde, which can be trapped with the dimedone (5,5-dimethyl-1,3-cyclohexadione). The formaldehyde-dimedone complex is extracted with toluene. The radioactivity in toluene is a measure of C-1 units produced by the enzyme.

i) Rat liver

The reaction was carried out in a 10 ml blood collection tubes (Vacutainer) (Becton Dickinson, France). The reaction volume was 0.5 ml; the mixture contained 0.2 mM pyridoxal phosphate, 2 mM L-tetrahydrofolate, 12 mM β -mercaptoethanol, 60 mM phosphate buffer (pH 7.4) and 100 μ l liver homogenate (1 mg tissue). The tubes containing the reaction mixture were kept at 37°C for 5 min and the reaction was started by the addition 10 mM L-(3-¹⁴C)serine (0.02 mCi/mmol). After incubation for 10 and 20 min, the reaction was terminated by the addition of 0.3 ml 1 M Sodium acetate (adjusted to pH 4.5 with concentrated HCl). To it were added 0.2 ml formaldehyde (0.1 M) and 0.3 ml dimedone (0.4 M dissolved in 50% v/v ethanol). The tubes were covered with marbles and heated in a boiling water bath for 5 min and then cooled in ice. After warming the tubes to room temperature, 5.0 ml toluene was added. The radioactive formaldehyde-dimedone adduct was extracted by shaking for 10 min in a multitube vortexer (Scientific Manufacturing Industries, Model 2601) at speed 3 for 10 min. The tubes were centrifuged at about 1000xg for 5 min at room

temperature to separate the aqueous and toluene layers, 3 ml of toluene was removed and added to 10 ml of scintillant for radioactive counting. Values for homogenate-free blanks were subtracted from assay values. A radioactive standard of 0.001 μCi (0.05 μmol) of ($3\text{-}^{14}\text{C}$)serine in 3 ml of toluene was counted in 10 ml of scintillant.

There was a linear relationship between the amount of formaldehyde formed and both time (0-30 min) and homogenate concentration (0-1.5 mg/reaction mixture) (Fig. 9).

ii) Sheep liver

The procedure was as described above for rat liver except that 100 μl homogenate of 0.5% (w/v) (0.5 mg tissue) was used in the reaction mixture. A linear relationship existed between HCHO formed and both time (0-30 min) and homogenate concentration (0-1 mg tissue/ reaction mixture) (Fig. 10).

iii) Rat diaphragm and hind-limb

The procedure was similar to that described for rat liver except that 100 μl of 10% (w/v) homogenate of both diaphragm and hind-limb muscle was used. Also the reaction was started by the addition of 10 mM ($3\text{-}^{14}\text{C}$)serine (0.06 mCi/mmol) instead of 10 mM ($3\text{-}^{14}\text{C}$)serine (0.02 mCi/mmol). The reaction was stopped after 10 and 20 min. A radioactive standard of 0.003 μCi /0.05 μmol of ($3\text{-}^{14}\text{C}$)serine in 3 ml of toluene was counted in 10 ml of scintillant.

- Fig. 9. a) Effect of homogenate concentration on serine hydroxymethyltransferase activity of rat liver
- b) Effect of time of incubation on serine hydroxymethyltransferase activity of rat liver

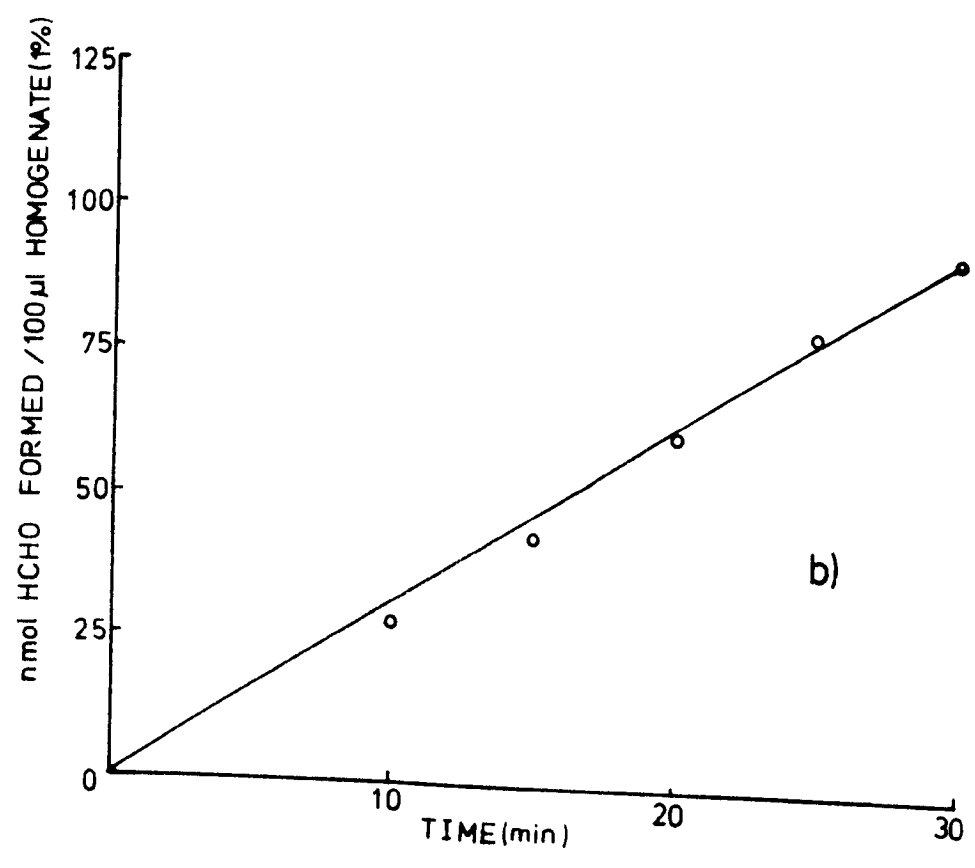
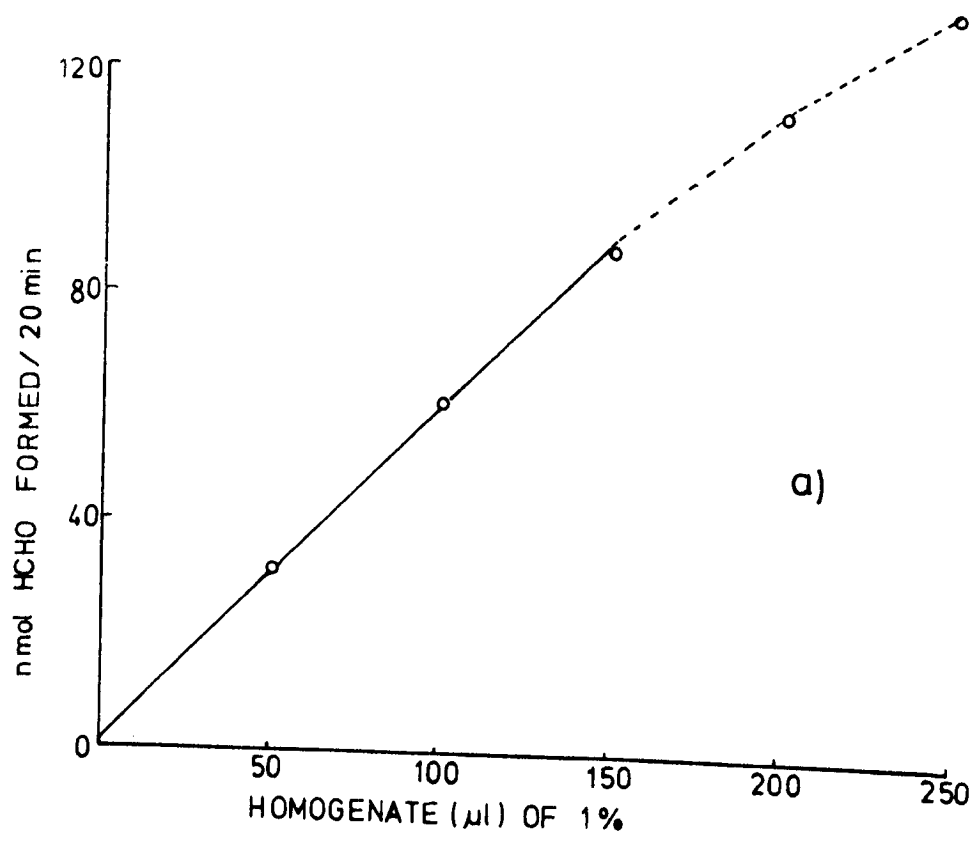

- Fig. 10. a) Effect of homogenate concentration on serine hydroxymethyltransferase activity of sheep liver
- b) Effect of time of incubation on serine hydroxymethyltransferase activity of sheep liver

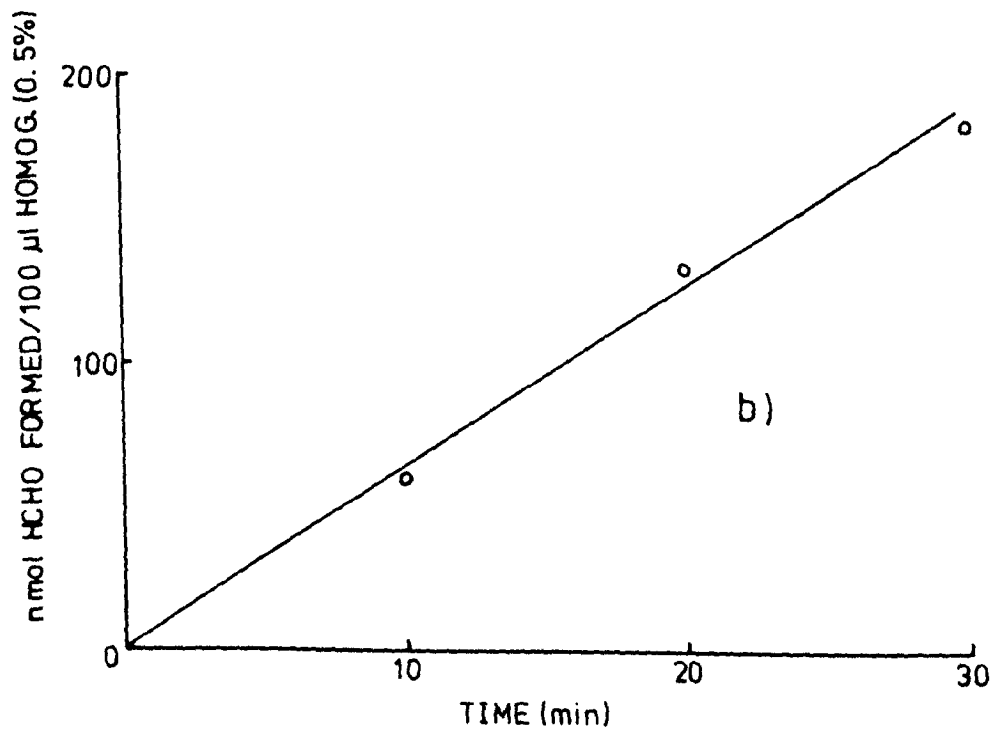
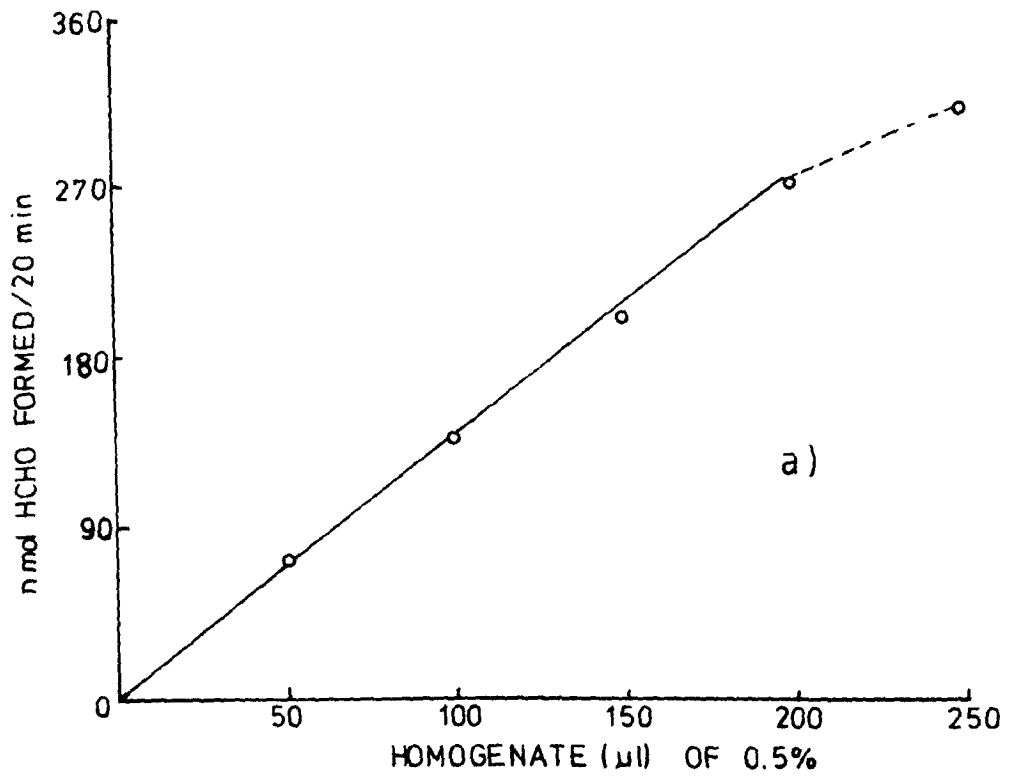

- Fig. 11. a) Effect of homogenate concentration on serine hydroxymethyltransferase activity of rat diaphragm
- b) Effect of time of incubation on serine hydroxymethyltransferase activity of rat diaphragm

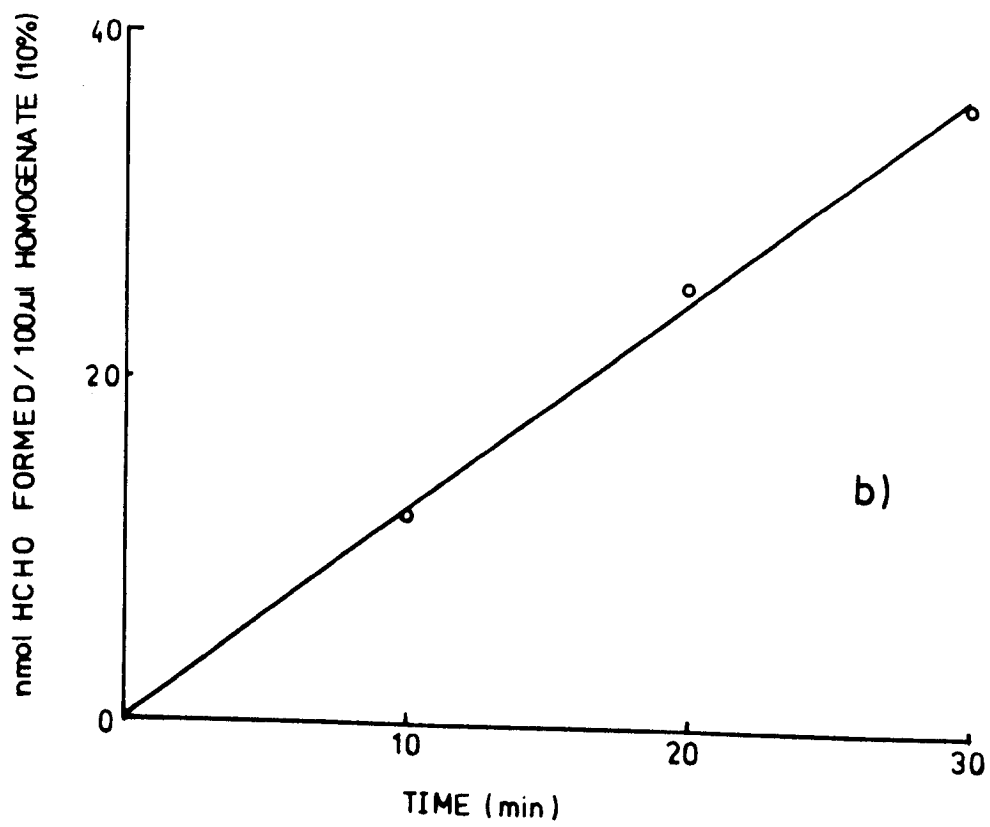
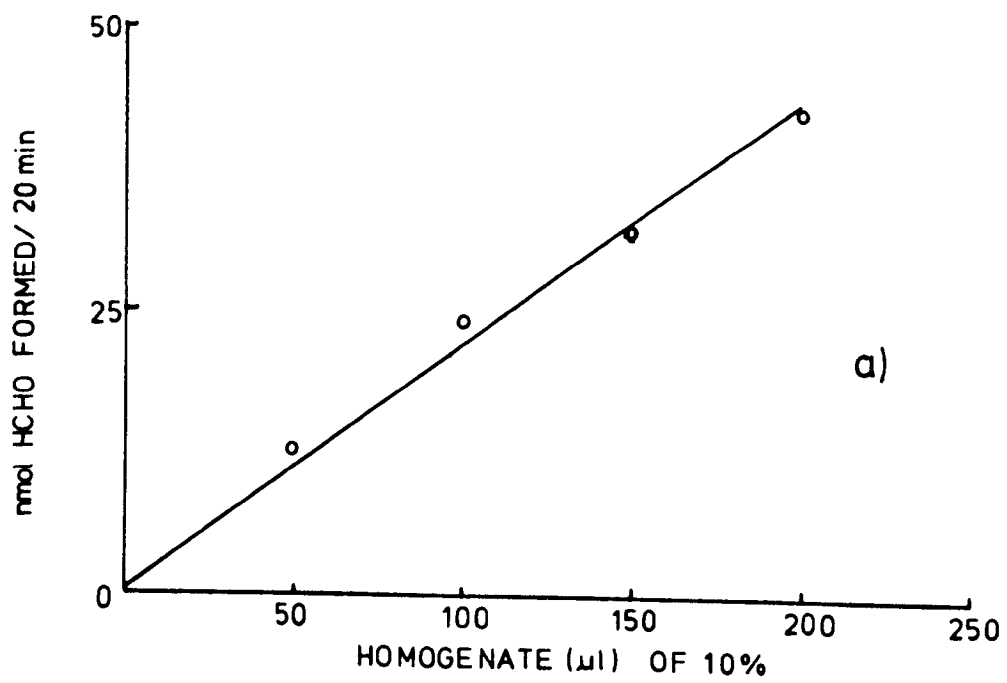

- Fig. 12. a) Effect of homogenate concentration on serine hydroxymethyltransferase activity of rat hind-limb muscle
- b) Effect of time of incubation on serine hydroxymethyltransferase activity of rat hind-limb muscle

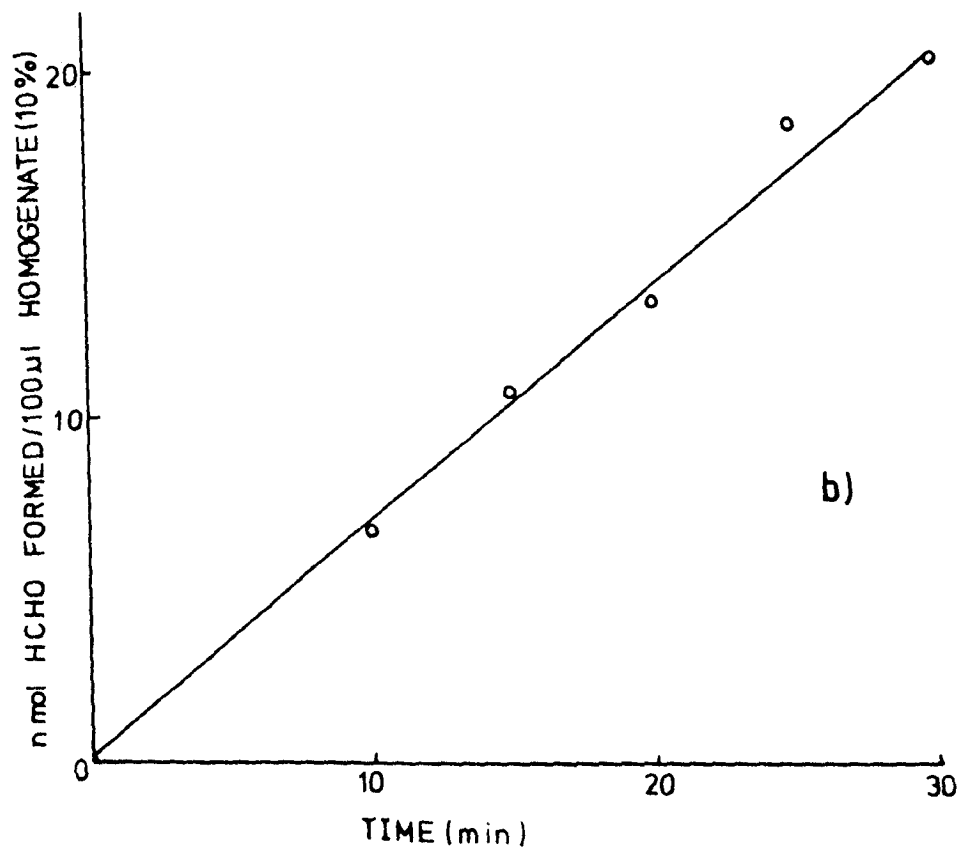
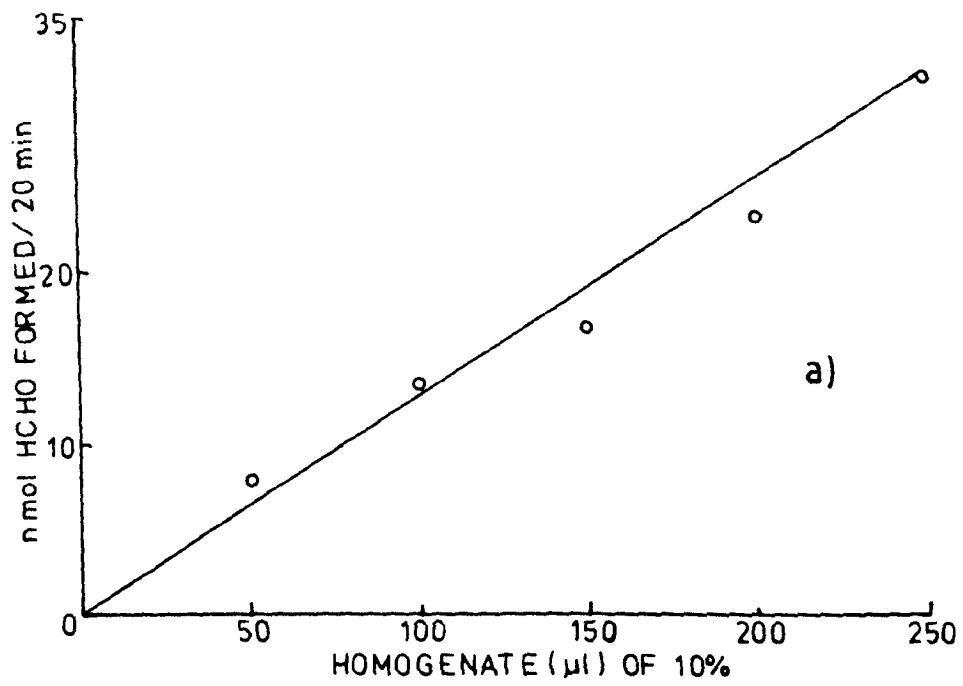

- Fig. 13. a) Effect of homogenate concentration on serine hydroxymethyltransferase activity of sheep diaphragm
- b) Effect of time of incubation on serine hydroxymethyltransferase activity of sheep diaphragm

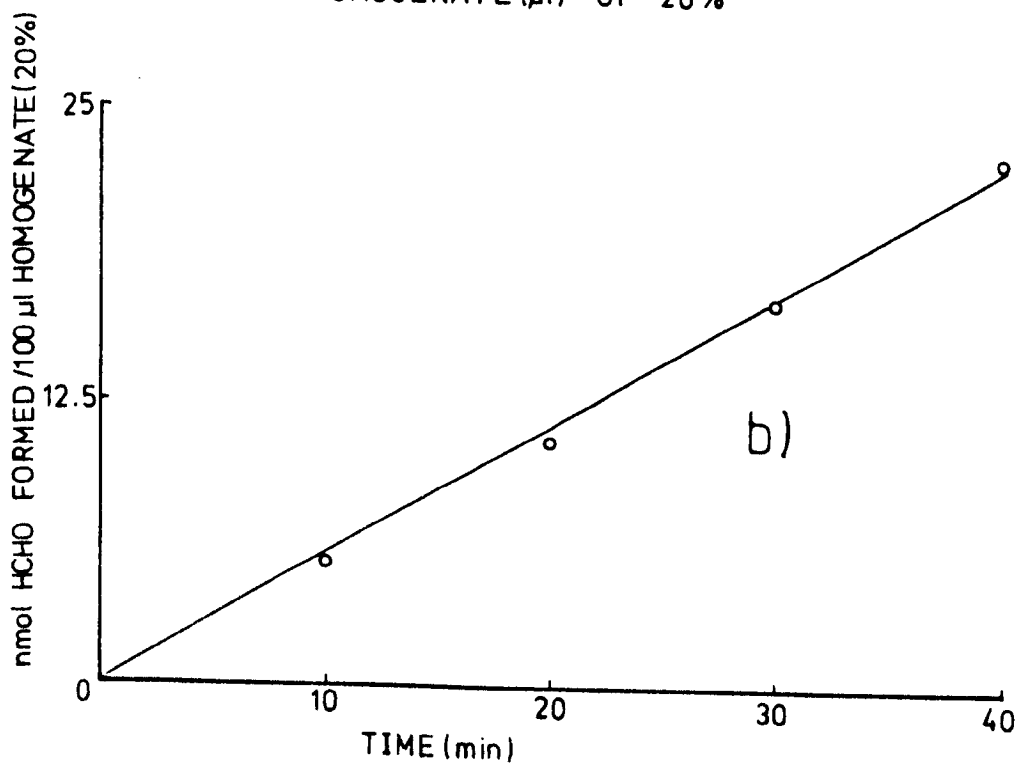
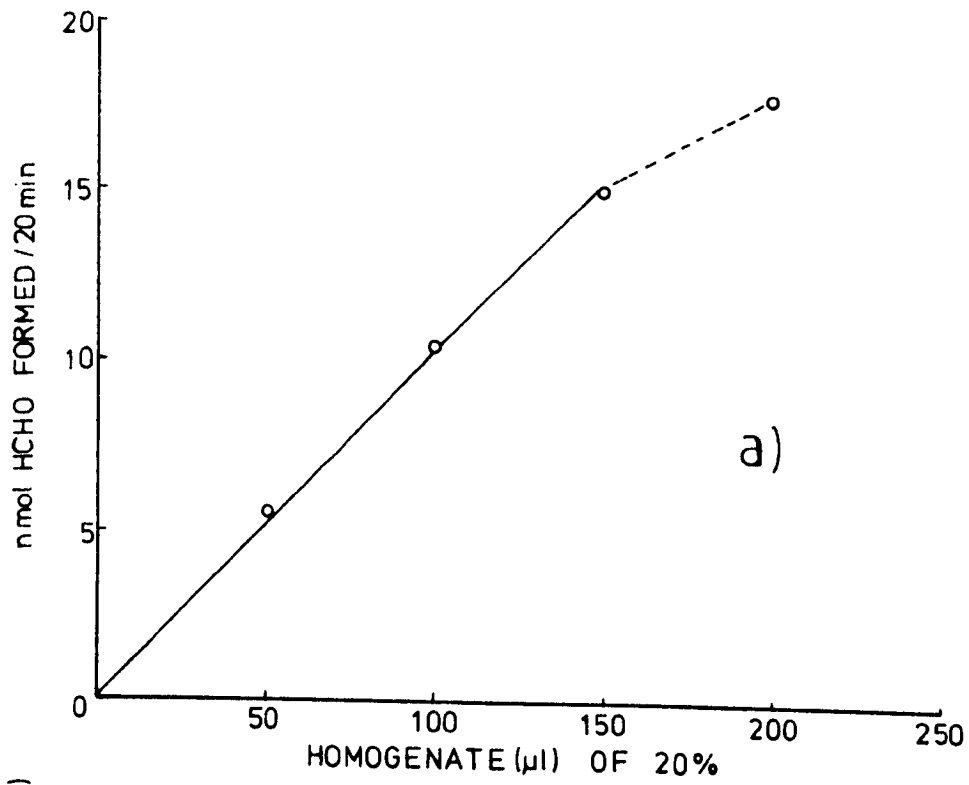

- Fig. 14. a) Effect of homogenate concentration on serine hydroxymethyltransferase activity of sheep hind-limb muscle
- b) Effect of time of incubation on serine hydroxymethyltransferase activity of sheep hind-limb muscle

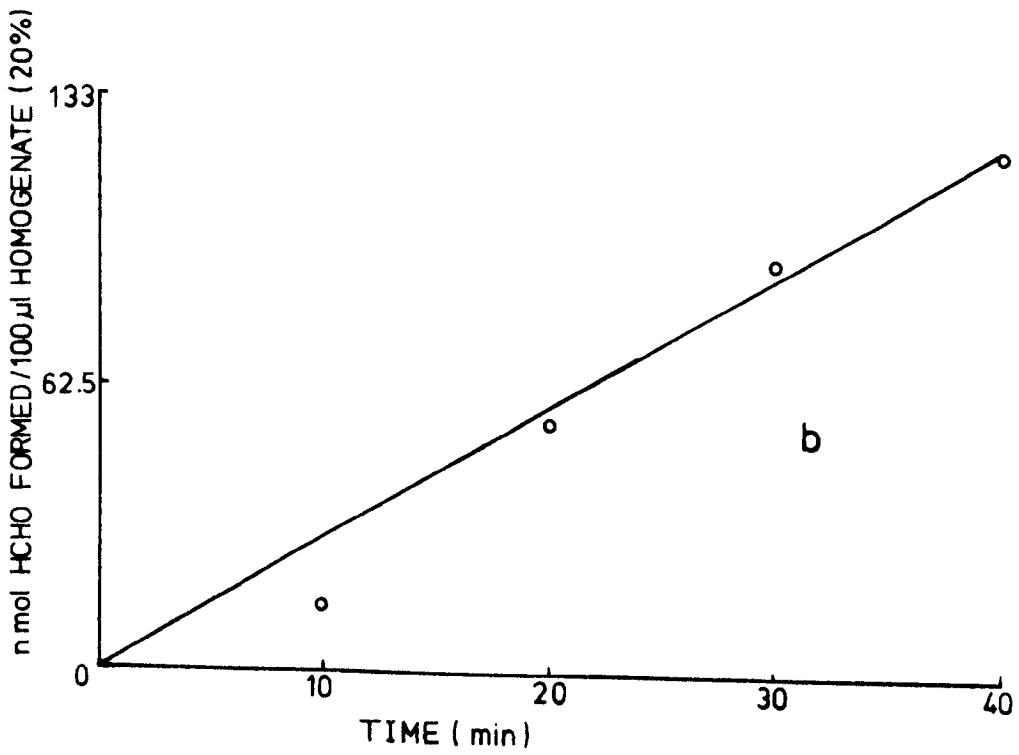
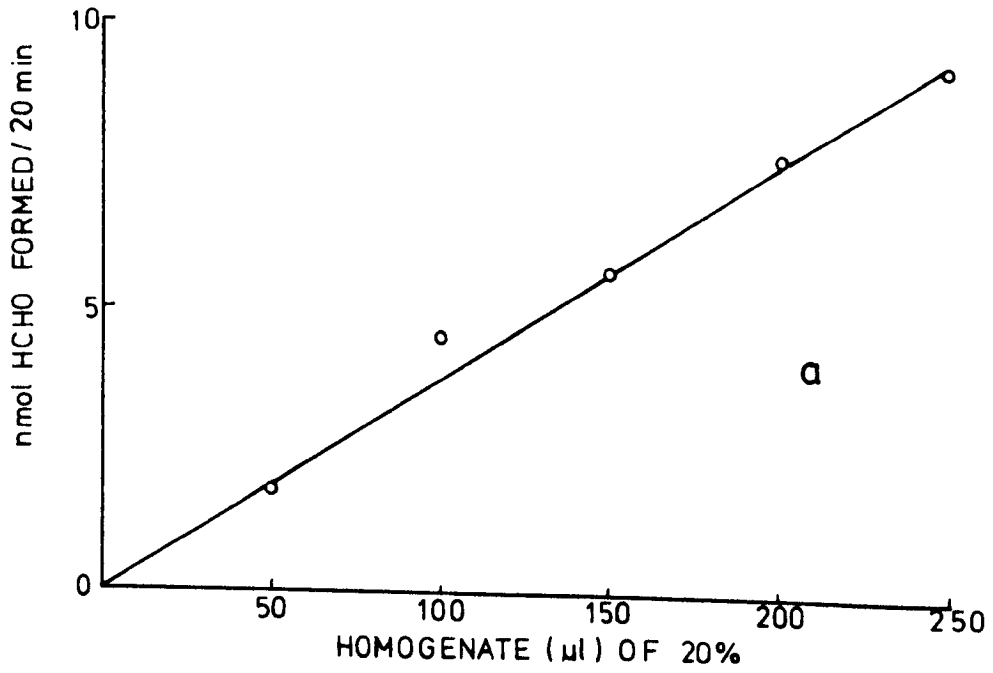

In the case of both the rat diaphragm and hind-limb muscle, there was a linear relationship between the amount of product and both time (0-30 min) and homogenate concentration (0-20 mg tissue/reaction mixture for rat diaphragm and 0-25 mg tissue/reaction mixture for hind-limb muscle) (Fig. 11 & 12).

iv) Sheep diaphragm and hind-limb muscle

The procedure was as described for rat diaphragm and hind-limb muscle except that 100 μ l of 20% (w/v) homogenate of both sheep diaphragm and hind-limb muscle was used in the reaction mixture. For both tissues the formaldehyde formed was linear with time (0-40 min) and homogenate concentration (0-30 mg for sheep diaphragm and 0-40 mg for sheep hind-limb muscle) (Fig. 13 & 14).

The enzyme activity was expressed in units (1 unit = 1 μ mol HCHO formed/min at 37°C).

2.16. ESTIMATION OF C-1 LABEL IN RADIOLABELLED GLYCINE

The procedure described by Rowsell et al. (1975), which is based on the method of Van Slyke (1941), was used with some modifications. A sample (0.1-0.5 ml, ca 2000 dpm) of 14 C-glycine isolated from the split-stream amino acid analyser (for the isolation see below) was mixed with 40 μ mol of glycine (0.2 ml) and 4 ml of acetate buffer (pH 5.5, 0.4 M) in a 25 ml conical flask kept on ice. About 200 mg ninhydrin was added to the flask. Then the flask was heated in a gently boiling water bath for 90 min with a

continuous flushing of nitrogen. The outflowing stream of gases was passed through about 50 ml concentrated sulphuric acid in 100 ml conical flask, then the CO_2 (CO_2 is evolved from C-1 of glycine by ninhydrin) was trapped by passing it through 4 ml of 1 M hyamine hydroxide in methanol (Fig. 15). The tip through which the gases passed into the hyamine hydroxide was kept narrow so that the emerging gases formed very small bubbles. In addition, the hyamine hydroxide was used in a scintillation vial inserts, which provided more contact between the gases and hyamine hydroxide than when a glass scintillation vial is used. A total of 14 ml scintillation fluid was used to transfer the contents of each insert quantitatively to a glass vial. The radioactivity was determined in the glass vial. If the emerging gases were passed through methanol after passing through sulphuric acid this had no effect on the recoveries and so the methanol wash was not used. In preliminary studies a second insert containing hyamine hydroxide was used in series with the first but this trapped less than 1% of the radioactivity of the first. In all subsequent studies only one insert was used. The trapping efficiency was tested by using (1- ^{14}C)glycine and trapping CO_2 liberated. The recoveries were > 92%. On using (2- ^{14}C)glycine (ca 80,000 dpm) only 0.29% of the total dpm were recovered in hyamine hydroxide suggesting that HCHO originating from C-2 of glycine after its degradation was not being carried to hyamine hydroxide to any significant extent.

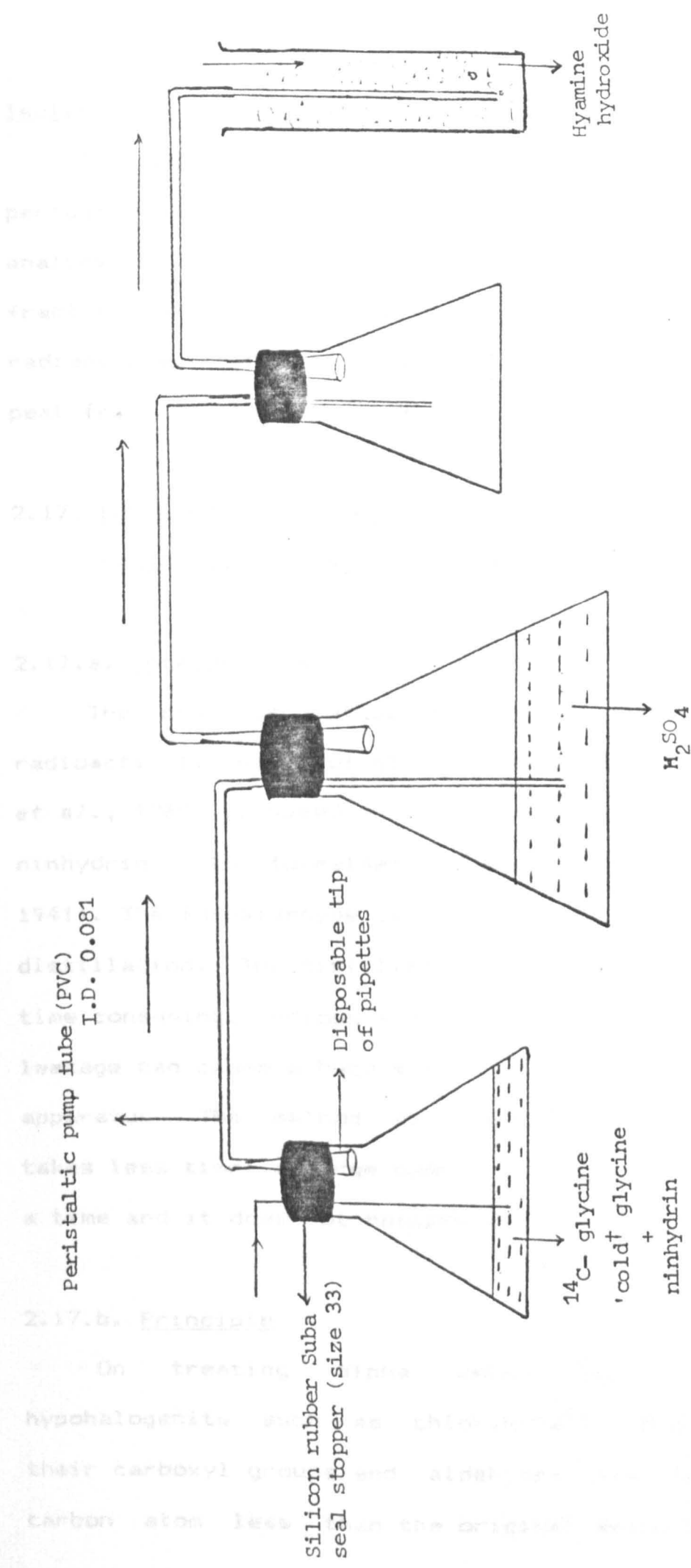

Fig. 15 Apparatus for determination of radioactivity in C-1 of glycine

Isolation of ^{14}C -glycine

The deproteinised sample (see section 2.12.a.) of 3 h perfusate was loaded on the split-stream amino acid analyser. The glycine peak was spread across about 18 fractions of one min each; 50 μl of each was taken for radioactive counting. About 9 fractions were pooled — the peak fraction and four on either side.

2.17. DEVELOPMENT OF A METHOD FOR DETERMINATION OF RADIOACTIVITY IN C-2 OF GLYCINE

2.17.a. Introduction

The previous method used for the determination of radioactivity in C-2 of glycine (kawasaki et al., 1966; Sato et al., 1969) is based on the degradation of glycine by ninhydrin into formaldehyde and CO_2 (Van Slyke et al., 1941). The formaldehyde is trapped with dimedone following distillation. The distillation of samples makes this method time consuming, tedious and laborious and also a slight leakage can cause a huge error. Moreover it requires special apparatus. The method developed by the author is simple, takes less time, a large number of samples can be handled at a time and it does not require distillation.

2.17.b. Principle

On treating alpha amino acids with alkali hypohalogenite such as chloramine T, CO_2 is evolved from their carboxyl groups and aldehydes are formed with one carbon atom less than the original amino acids (Van Slyke

et al., 1941; Sardesai and Provido, 1970). Degradation of glycine forms CO_2 and formaldehyde which originate from C-1 and C-2 of glycine respectively.

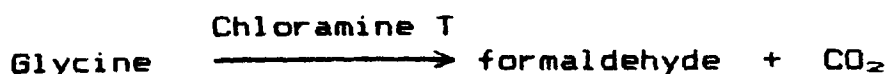

The trapping of formaldehyde provides the estimate of radioactivity in C-2 of glycine.

,Sardesai and Provido (1970) estimated glycine by its degradation with chloramine T to HCHO which was then measured by acetyl acetone reagent. However, in the present method of estimating radioactivity in C-2 of glycine, the formaldehyde formed was trapped with dimedone and the formaldehyde-dimedone complex was extracted in toluene. The radioactivity in the toluene was measured.

2.17.c. Method

An aliquot (0.1 ml) of authentic ($2\text{-}^{14}\text{C}$)glycine was placed in a 10 ml centrifuge tube or in a 10 ml blood collection tube (Vacutainer) (Becton Dickinson, France). To it were added 0.1 ml of glycine (10-80 μg), 0.1 ml of 76 mM chloramine T and 0.5 ml of sulphuric acid (0.1 M). These were mixed and kept in an oil bath adjusted at $135\text{-}137^\circ\text{C}$ for exactly 50 sec. The tubes were then transferred to ice. After about 5 min the pH of the solution was brought to 4.5 by the addition of 0.5 ml of 3 M sodium acetate (pH 4.5) and then 0.2 ml of formaldehyde (0.1 M) and 0.4 ml of dimedone (0.4 M, in 50% ethanol) were added. The tubes were covered

using marbles and heated in a boiling water bath for 10 min. The tubes were then cooled on ice. After warming the tubes to room temperature 5.0 ml toluene was added to extract the formaldehyde - dimedone complex. The radioactive formaldehyde - dimedone complex was extracted by shaking the tubes in a multitube vortexer (Scientific Manufacturing Industries, Model 2601) at speed 3 for 10 min. The tubes were centrifuged at about 1000xg for 5 min at room temperature to separate aqueous and toluene layers. An aliquot (3.0 ml) of toluene layer was removed and added to 10 ml of scintillant for radioactive counting. An aliquot (0.1 ml) of the authentic (2-¹⁴C)glycine was counted directly (3.0 ml toluene plus 10 ml scintillant) for calculation of per cent recovery.

The degradation conditions used were that employed by Sardesai and Provided (1970) except that 76 mM chloramine T was used and the time for which the samples were kept in oil bath was 50 sec (see below).

2.17.d. Results and Discussion

i) Effect of time of heating at different concentrations of chloramine T

Table 7 shows the effect of keeping the tubes at 135-137 °C for different length of time on the recoveries of radioactivity in C-2 of glycine (glycine concentration, 20 µg/sample). Chloramine T at two concentrations was used, 0.1 ml each of 38 mM and 76 mM per sample. Using 0.1 ml of 38 mM chloramine T a time of 45-90 sec was optimum, whereas for 0.1 ml of 76 mM chloramine T the optimum time was

Table 7. Effect of keeping the tubes at 135-137 °C for different lengths of time on the recoveries of radioactivity in C-2 of glycine

Time (sec)	% Recovery	
	on addition of chloramine T (0.1 ml) of	
	38mM	76mM
30	53.7	66
45	100.4	94.3
60	100.2	93.5
75	-	89.7
90	101.1	87
120	94.7	77.9
180	87.3	67.9
240	78.3	-
300	69.8	-

Glycine concentration in the sample was 20 μ g

45-60 sec. Times of 60 sec and 50 sec were chosen for the estimation of radioactivity in C-2 of glycine when 0.1 ml of 38 mM and 76 mM respectively of chloramine T were used.

ii) Effect of glycine concentration at two different concentrations of chloramine T

Table 8 shows the effect of two different concentrations of chloramine T on the recoveries of radioactivity in C-2 of glycine when the glycine concentration was changed. On using chloramine T (0.1 ml of 38 mM) the per cent recoveries were satisfactory upto glycine concentration of 40 μ g per sample. However, at higher concentrations of glycine the recoveries decreased. With 0.1 ml of 76 mM chloramine T the per cent recoveries were satisfactory at glycine concentrations as high as 100 μ g in the sample. Chloramine T (0.1 ml of 76 mM) appeared to degrade completely the glycine upto 100 μ g in the sample. This concentration of chloramine T was selected for further experiments.

iii) Effect of different levels of (2- 14 C)glycine radioactivity

Using 0.1 ml of 76 mM chloramine T and glycine at a concentration of 40 μ g in the sample, the method was tested using different quantities of authentic (2- 14 C)glycine (Table 9). At all the levels of (2- 14 C)glycine tested, the recoveries were satisfactory suggesting the applicability of the method at wide range of (2- 14 C)glycine radioactivity.

Table 8. Effect of different concentrations of glycine on the recoveries of radioactivity in C-2 of glycine at two different concentrations of chloramine T

Glycine in the sample (μg)	% Recovery using chloramine T (0.1 ml) of	
	38mM	76mM
20	99.8	101
40	96	101
60	84	102
80	-	98.8
100	62.7	99

Time for which the samples were kept at 135-137 °C was 60 sec when 0.1 ml of 38mM chloramine T was used and 50 sec when 0.1 ml of 76mM chloramine T was used

Table 9. Effect of different quantities of authentic
(2-¹⁴C) glycine on the recoveries of C-2

(2- ¹⁴ C)glycine used (dpm)	% Recovery
2161	95% - 101%
4293	98.4
8402	100.7
19001	87.5
39597	104.9

Chloramine T used : 0.1 ml of 76mM
Time for which samples kept in oil bath (135-137°C) :
50 sec

iv) Effect of addition of (1-¹⁴C)glycine instead of (2-¹⁴C)glycine

(1-¹⁴C)glycine in place of (2-¹⁴C)glycine was used in order to study the specificity of the method. (1-¹⁴C)glycine (ca 40,000 dpm) was added. Virtually no (< 0.5 % of the added) radioactivity was obtained as (2-¹⁴C)glycine, suggesting that (1-¹⁴C)glycine did not interfere with the estimation of radioactivity at C-2 of glycine.

v) Degradation of glycine at room temperature

Van Slyke et al. (1941) reported that chloramine T causes the evolution of CO₂ from amino acids at a temperature as low as 20°C. The degradation of glycine with chloramine T was carried out at room temperature (ca 22°C) for 10 min (the rest of the conditions for degradation were the same as above). The per cent recovery of radioactivity at C-2 was only 15% suggesting that degradation of glycine was not complete at this temperature and lower temperatures (about 20°C) can not be used for the determination of radioactivity in C-2 of glycine.

The optimum conditions of glycine degradation observed for the determination of radioactivity in C-2 of glycine were the use of 0.1 ml of 76 mM chloramine T at a temperature of 135-137°C for 50 sec.

vi) Optimum conditions for trapping HCHO

The pH of the degraded sample was brought to 4.5 for forming formaldehyde-dimedone complex as this pH is the

optimum for the complex formation (Yoe and Reid, 1941; Frisell and Mackenzie, 1958). In preliminary trials 0.5 ml of 1 M or 2 M sodium acetate (pH 4.5) were added to bring the pH of degraded sample to 4.5. A pH of below 4.5 was obtained with these. A 3 M solution (0.5 ml) of sodium acetate (pH 4.5) brought the pH of degraded sample to 4.5.

Dimedone in excess was added to form the formaldehyde-dimedone complex. Two moles of dimedone are required to every 1 mole of formaldehyde for the complex formation. However, a molar excess of dimedone as large as 50:1 over formaldehyde does not interfere with the quantitative formation of the complex (Frisell and Mackenzie, 1958).

The method described here can also be extended to the determination of radioactivity at the beta carbon of serine after periodate treatment which leads to the formation of glyoxylate and formaldehyde (Frisell and Mackenzie, 1958).

2.18. DETERMINATION OF RADIOACTIVITY IN C-2 OF GLYCINE OBTAINED FROM PERFUSION EXPERIMENTS BY THE CHLORAMINE T METHOD

Radioactive glycine was isolated from the perfusion medium using split-stream ion-exchange amino acid analysis (section 2.16.). It was therefore present in lithium amino acid analyser buffer (pH 2.58, Table 6). The recoveries of radioactivity in C-2 of authentic (2-¹⁴C)glycine in lithium

buffer (pH 2.58) were studied. The recoveries were < 5%, which suggested that the addition of lithium amino acid analyser buffer interfered with the degradation of glycine by the chloramine T method, probably due to change in pH of the sample (Van Slyke et al., 1941).

The interference of the buffer was eliminated by removing radioactive glycine from the lithium buffer. The radioactive glycine isolated from the split-stream amino acid analyser was passed through a previously prepared column of Dowex 50x8 cation resin (H⁺), 100-200 mesh (preparation of the column is described below). The resin bed was washed with about 200 ml of distilled water and effluent discarded. Glycine was retained on the column whereas other moieties of the sample passed through with the water. Glycine was eluted from the column with about 150 ml of 4 M ammonium hydroxide. Ammonium hydroxide was removed by evaporating the eluted sample on rotary evaporator. The dried sample was washed with distilled water and again dried. The dried glycine was dissolved in distilled water. An aliquot of this sample was taken for the determination of radioactivity in C-2 of glycine.

Authentic (2-¹⁴C)glycine (2.0 ml, 40 µg cold glycine) in the lithium buffer (pH 2.58) was passed through the Dowex 50 (H⁺) column and eluted with ammonium hydroxide (4 M). The final volume was made upto 2.0 ml with distilled

water after drying the eluted sample. Recovery of (2-¹⁴C)glycine after passing through the column was 95%.

	0.1 ml had	% Recovery of (2- ¹⁴ C)glycine
Before passing through column	2468 dpm	--
After passing through column	i) 2352 dpm	95.3
	ii) 2337 dpm	94.7

Aliquots (0.1 ml) of these samples (before and after passing the column) were taken for estimation of radioactivity in C-2 of glycine. The results are presented below; they show that the interference was removed after passing the material through the column.

	dpm added	dpm recovered	% Recovery of ¹⁴ C-2
Before	2468	i) 115	4.66
		ii) 117	4.74
After	2344	i) 2122	90.53
		ii) 2150	91.72
		iii) 2222	94.79
		iv) 2217	94.58

2.19. PREPARATION OF RESIN (DOWEX 50x8, H⁺ FORM) COLUMN

A suspension of Dowex 50x8 (100-200 mesh) in distilled water was poured into a column with a glass wool plug at the bottom to support the bed of resin. The size of the resin bed was approximately 100 mm x 10 mm. About 100 ml of 1 M HCl was passed through the column containing the resin followed by about 200 ml of distilled water. The column then was ready for loading the sample. The resin was reused after regeneration. Between each sample, the resin was removed from the column in a filter and washed with about 300 ml of distilled water, 60 ml ammonium hydroxide (4 M) and finally with 500 ml of distilled water. The resin was then returned to the column and washed with 100 ml of 1 M HCl followed by 200 ml of distilled water before passing the next sample through.

RESULTS

A. STUDIES ON VIABILITY OF PERFUSED ORGANS

3.1. VIABILITY TESTS OF PERFUSED ORGANS

3.1.a. The rat hind-limb

i) Perfusion with erythrocyte containing medium

a) Appearance and flow rate

A short period of anoxia (3-4 min) was unavoidable from the time aorta and vena cava were cannulated to the connection of isolated hind-limb preparation to the apparatus. During this time of anoxia the feet of the animal lost their normal pink colour *in vivo* and became pale. The normal pink colour of the feet returned within 6 min of start of perfusion and remained so throughout a 3 h perfusion period.

Oedema was not visible on the surface of hind-limb preparation. A steady flow rate of about 0.33 ml/min/g muscle was usually maintained throughout a 3 h perfusion at an arterial pressure of 8-9 cm Hg. In perfusions where a marked decrease in flow rate occurred, (which rarely happened after some of the initial perfusions) the results were discarded.

b) Muscle water content

The water content of 3 h perfused muscle was the same as observed for fresh muscle (Table 10).

c) pH measurements

The initial pH of the perfusate was adjusted to 7.3-7.4. A decrease of $0.17 \pm 0.014(3)$ pH units was observed after 3 h of perfusion.

d) Perfusate potassium concentration

Release of potassium from the muscle in 3 h was 313 ± 13.6 (4) $\mu\text{mol}/30$ g muscle. Recirculation of the perfusate in absence of a hind-limb preparation gave rise to an increase of 86 $\mu\text{mol K}^+$ in 3 h. This increase probably represented leakage of K^+ from erythrocytes. So, the contribution of muscle to K^+ efflux during a 3 h perfusion period was 227 $\mu\text{mol}/30$ g muscle. This increase in K^+ content represented a loss of 5.5% of total tissue K^+ (the K^+ content of hind-limb muscle was 4.1 ± 0.02 (4) $\text{mmol}/30$ g muscle; Ward, 1976).

ii) Perfusion with erythrocyte-free medium

a) Appearance and flow rate

There was no oedema and cyanosis. A constant flow rate of 16-19 ml/min was observed at a pressure of 8-9 cm Hg throughout the perfusion period.

b) pH measurements

Initial pH of perfusate was kept 7.3-7.4. A decrease of 0.1-0.2 pH units was found after 3 h of perfusion.

c) Perfusate potassium concentration

Efflux of potassium in the medium was 257 ± 15.7 (3) $\mu\text{mol}/30$ g muscle/3 h. This efflux formed 6.3% of total muscle K^+ (the K^+ content of hind-limb muscle was 4100 ± 23 (4) $\mu\text{mol}/30$ g muscle; Ward, 1976). This loss is almost the same as observed with erythrocyte-containing medium.

Table 10. Viability of the rat hind-limb perfused with erythrocyte-containing and erythrocyte-free medium

	Erythrocyte containing medium	Erythrocyte free medium	Fresh muscle
Muscle water content (%)	75.3 ± 0.32(4) [76.76 ± 0.73(5)]	75.1 ± 0.23(3)	74.26 ± 0.28(4)
Potassium efflux (µmol/3h/30g)	227 ± 13.6(4) [270]	257 ± 15.7(3)	-
Muscle lactate (µmol/g)	-	4.78 ± 0.36(3)	4.58 ± 0.23(3)
Muscle pyruvate (µmol/g)	-	0.18 ± 0.03(3)	0.17 ± 0.02(3)
Lactate: pyruvate ratio	-	27.42 ± 3.61(3)	27.81 ± 3.19(3)
ATP (µmol/g)	- [5.43 ± 0.23(3)]	7.09 ± 0.7(3)	7.49 ± 0.34(3) [5.94 ± 0.06(3)]
ADP (µmol/g)	- [1.06 ± 0.14(3)]	0.71 ± 0.07(3)	0.71 ± 0.03(3) [0.98 ± 0.15(3)]
ATP/ADP	- [5.28 ± 0.50(3)]	10.01 ± 0.84(3)	10.6 ± 0.56(3) [6.38 ± 1.08(3)]

The results of the present study were not significantly different between groups
The values in square parentheses are that of Ward and Buttery (1979)

d) Muscle water content

There was no difference in the water content of 3 h perfused and fresh muscle (Table 10).

e) Muscle lactate, pyruvate and lactate/pyruvate ratio

Lactate and pyruvate concentrations and the lactate/pyruvate ratio of perfused and fresh muscle are presented in Table 10. There was no significant change in either the concentration of lactate and pyruvate or the lactate/pyruvate ratio following 3 h perfusion.

f) Muscle ATP, ADP and ATP/ADP ratio

The concentrations of ATP in muscle after 3 h perfusion and *in vivo* were $7.09 \pm 0.7(3)$ $\mu\text{mol/g}$ and $7.49 \pm 0.34(3)$ $\mu\text{mol/g}$ muscle respectively and those of ADP were $0.71 \pm 0.07(3)$ $\mu\text{mol/g}$ and $0.71 \pm 0.03(3)$ $\mu\text{mol/g}$ muscle respectively. These values of ATP and ADP in the perfused muscle compared with *in vivo* were not significantly different. There was no drop in the ATP/ADP ratio following perfusions (Table 10).

3.1.b. The sheep diaphragm

(Sheep diaphragms were perfused with erythrocyte-free medium, see section 2.6.)

i) Macroscopic appearance and flow rate

A little oedema was visible. Some degree of fibre separation was also observed after 3 h of perfusion, as judged by visual examination. A steady flow of 10-13 ml/min

was maintained throughout the perfusion at a perfusion pressure of 8-9 cm Hg. In perfusions where a flow rate of < 10 ml/min was observed, the results were discarded.

ii) pH measurements

The initial pH of the perfusate was 7.3 to 7.4. A decrease in perfusate pH of 0.1 to 0.15 units was observed during a 3 h perfusion period. As the decrease in pH of the perfusate was very small, it was not adjusted to the initial pH value during the perfusion.

iii) Muscle water content

Following 3 h perfusion, a small but significant ($P < 0.05$) increase in water content was observed (perfused muscle, $77.4 \pm 0.43(13)\%$; fresh muscle, $75.3 \pm 0.41(4)\%$).

iv) Muscle extracellular space

The extracellular space of the perfused muscle was determined by using (^3H) inulin in the perfusion medium. An increase in the extracellular space or inulin-space was observed in the perfused muscle [perfused muscle, $0.3 \pm 0.15(3)$ ml/g; fresh muscle, $0.20 \pm 0.02^*(6)$ ml/g (* data from Beckerton, 1976)]. The muscle extracellular space of the perfused muscle was more variable than that of fresh muscle, and is an indication of variability in the extent of oedema observed following the perfusion.

v) Loss of muscle potassium

The efflux of potassium in the medium by the diaphragm was 138.54 ± 14.6 (11) $\mu\text{mol}/3 \text{ h}/30 \text{ g}$ muscle. The potassium content of the diaphragm was found to be 2.97 ± 0.13 (3) $\text{mmol}/30 \text{ g}$ muscle. The loss of potassium from the muscle following 3 h perfusion was 4.66 ± 0.48 (11)% of the total muscle potassium.

vi) Lactate and pyruvate production

Lactate and pyruvate production over a 3 h perfusion period were 641.77 ± 28.4 (3) μmol and 5.05 ± 0.37 (3) μmol respectively by 30 g muscle.

vii) Muscle glycogen content

No significant difference ($P > 0.05$) in the glycogen content of the 3 h perfused and fresh muscle was found (perfused muscle, 9.42 ± 0.49 (3) mg glucose equivalent/g; fresh muscle, 9.61 ± 0.62 (4) mg glucose equivalent/g). The values are quite close to that reported by Coward and Buttery (1980). The glycogen content of the sheep diaphragm was lower than that of bovine longissimus muscle (Crouse et al., 1984).

viii) Muscle lactate, pyruvate and lactate/pyruvate ratio

Table 11 shows the muscle lactate and pyruvate concentrations and muscle lactate to pyruvate ratio of perfused and fresh muscle. There was no significant

difference in the concentrations of either lactate or pyruvate between perfused and fresh muscle. There was increase in muscle lactate to pyruvate ratio but the increase was not significant ($P > 0.05$).

ix) Muscle ATP, ADP and AMP content and ATP/ADP and (ATP)/(ADP+AMP) ratios

There was no significant decline in the muscle ATP and AMP. However, a significant decline in ADP content was observed (Table 11). The reason for decline in ADP content is not clear. A similar change in muscle ADP was observed by Coward and Buttery (1980) and by Shepperson (1983) in their perfusions using erythrocyte-containing medium. As a result of decline in muscle ADP but no change in ATP and AMP content the muscle ATP/ADP and (ATP)/(ADP+AMP) ratios increased following perfusion (Table 11).

It is noteworthy that the method used for estimation of ATP in the present work also measured ITP, GTP and UTP (Jaworek et al., 1974a) whilst that used for ADP estimation also measured IDP, GDP, UDP and CDP (Jaworek et al., 1974b). However, these interfering nucleotides are present in very low amounts in normal muscle (Schmitz et al., 1954), in muscle post-mortem (Lawrie, 1974) and in anoxic perfused rat heart (Jefferson et al., 1971). So it is unlikely that any changes in the concentration of these interfering nucleotides during perfusion would affect the results obtained to a large extent.

Table 11. Viability of the perfused sheep diaphragm

(A) Muscle constituents

	<u>Fresh muscle</u>	<u>Perfused muscle</u>
Muscle water content (%)	75.3 ± 0.41(4) [75 ± 0.12(6)]	77.4 ± 0.43(13)* [77.3 ± 0.74(12)*] {75.8 ± 0.3(19)}
Muscle ATP (μmol/g)	0.952 ± 0.04(4) [2.49 ± 0.24(9)] {2.24 ± 0.47(2)}	0.983 ± 0.15(4) [1.94 ± 0.18(10)] {1.73 ± 0.33(5)}
Muscle ADP (μmol/g)	0.98 ± 0.07(5) [1.0 ± 0.07(6)]	0.50 ± 0.06(4)** [0.48 ± 0.007(3)*] {0.147 ± 0.27(5)}
Muscle AMP (μmol/g)	0.41 ± 0.08(5)	0.37 ± 0.09(4)
Muscle ATP/ADP	1.018 ± 0.086(4) [2.83 ± 0.111(4)]	2.164 ± 0.52(4)+ [4.24 ± 0.061(3)]***
Muscle (ATP)/(ADP+AMP)	0.66 ± 0.09(3)	1.12 ± 0.13(4)*
Muscle pyruvate (μmol/g)	0.099 ± 0.012(5)	0.084 ± 0.014(4)
Muscle lactate (μmol/g)	7.86 ± 1.44(4)	8.44 ± 0.85(4)
Muscle lactate/pyruvate	85.0 ± 16(4)	109.0 ± 17(4)
Muscle phospho-creatine (μmol/g)	2.22 ± 0.21(4)	1.43 ± 0.21(4)*
Muscle glycogen (mg glucose equivalent)	9.42 ± 0.49(3) [11.5 ± 1.15(5)]	9.61 ± 0.62(4) [8.2 ± 0.71(12)*]
Muscle extra-cellular space (ml/g)	0.20 ± 0.02(6)*	0.30 ± 0.15(3) [0.26 ± 0.02(5)]

a, data from Beckerton (1976); +, P < 0.1; *, P < 0.05; **, P < 0.01; ***, P < 0.001
Data in [] from Coward and Buttery (1980)
Data in { } from Shepperson (1983)

Table 11. Viability of the perfused sheep diaphragm

(B) Lactate, pyruvate and potassium efflux

	Efflux <u>($\mu\text{mol}/3\text{h}/30\text{g}$ muscle)</u>
Lactate	641.77 ± 28.4 (3) [1458 ± 89.7 (3) { 327 ± 126 (4)}]
Pyruvate	5.05 ± 0.37 (3) [14.82]
Potassium	138.54 ± 14.6 (11)

Data in [] from Coward and Buttery (1980)

Data in { } from Shepperson (1983)

x) Muscle phosphocreatine content

There was a significant ($P < 0.05$) decline in the muscle phosphocreatine concentration following 3 h perfusion (perfused muscle, $1.43 \pm 0.21(4)$ $\mu\text{mol/g}$; fresh muscle, $2.22 \pm 0.21(4)$ $\mu\text{mol/g}$).

xi) Oxygen consumption by the diaphragm

In preliminary experiments attempts were made to decrease the viscosity of the medium in order to increase the flow rate and hence provide a greater supply of oxygen to the organ. Bovine serum albumin (BSA) at a concentration of 4% and 6% were tried. With 4% BSA flow rates of 12 ml/min, 15 ml/min and 19 ml/min were observed at pressures of 7 cm, 8.5 cm and 10-10.5 cm of Hg respectively. On the other hand with 6% BSA flow rates of 10 ml/min, 13 ml/min, 16 ml/min and 18.5 ml/min were observed at 7 cm, 8 cm, 10.5 cm and 12 cm of Hg respectively. But with both 4% and 6% BSA the perfusions were found to be unsatisfactory as a high retention of medium (order of 55 ml in 2 h) in the preparation and high tissue water content (78-84%) were found, probably due to the low osmotic pressure of the medium.

Table 12 shows the relationship between the pressure, flow rate and oxygen uptake by the sheep diaphragm on using 8% BSA in the medium. At 7 cm of Hg the flow rate was 9 ml/min. Flow rates of 4-10 ml/min were observed by Shepperson (1983) and 7-8 ml/min by Coward and

Table 12. Oxygen uptake by the sheep diaphragm at different flow rates

Pressure (cm of Hg)	Flow rate (ml/min)	O ₂ uptake* (μ mol/h/g muscle)
6	6	5.21 ^a
7	9	7.80 ^b
8	11	9.34 ^c
9	13	8.66 ^d
10	14.5	8.80 ^e

* Mean values (n=3) by analysis of variance; pooled standard error of difference (SE) = 0.35
 Significance of difference : a v b,c,d,e P<0.001; b v c P<0.01; b v d P<0.05; b v e P<0.02; c v d,e ns (not significant)

Buttery (1980) at this pressure with the erythrocyte-containing medium. There was no significant difference in oxygen consumption by the diaphragm on increasing the flow rate from 11 ml to 14.5 ml/min. A significantly lower oxygen uptake was observed at flow rates of 6 ml/min and 9 ml/min. In the present study the flow rate generally varied from 10-13 ml/min at an arterial pressure of 8-9 cm of Hg. The oxygen consumption of the diaphragm under these conditions was $8.45 \pm 0.73(5)$ $\mu\text{mol/g/h}$.

xii) Ratio of the efflux of amino acids to tyrosine efflux

Table 13 gives the ratios of the efflux of individual amino acids to the tyrosine efflux observed in the present study together with those of Coward and Buttery (1982) (in their studies perfusions were carried out using erythrocyte containing medium). The ratios observed for all the amino acids in the present study are in close agreement with those of Coward and Buttery (1982). This also suggests that the preparation remained viable for 3 h when perfusions were carried out using erythrocyte-free medium.

Table 13. Ratio of individual amino acids to tyrosine for the efflux of amino acids from the perfused sheep diaphragm

Amino acids	Ratio of efflux of individual amino acid ($\mu\text{mol}/3\text{h}/30\text{g}$) to tyrosine efflux ($\mu\text{mol}/3\text{h}/30\text{g}$)	
	Present study (n=5)	From Coward & Buttery (1982) (n=6)
Asp	0.69 \pm 0.16	0.99 \pm 0.15
Thr	1.56 \pm 0.11	1.76 \pm 0.16
Ser	1.22 \pm 0.22	1.76 \pm 0.32
Glu	6.1 \pm 0.89	-
Gln	13.59 \pm 3.1	-
Gly	7.94 \pm 0.87	9.85 \pm 0.88
Ala	12.05 \pm 1.26	16.32 \pm 2.16
Val	2.0 \pm 0.15	2.15 \pm 0.14
Cys	0.61 \pm 0.14	-
Met	0.36 \pm 0.03	-
Ile	1.02 \pm 0.09	1.14 \pm 0.08
Leu	2.07 \pm 0.17	2.25 \pm 0.19
Phe	0.99 \pm 0.07	1.16 \pm 0.09
Lys	2.02 \pm 0.16	2.26 \pm 0.12
His	1.03 \pm 0.11	1.18 \pm 0.11
Arg	1.22 \pm 0.16	0.85 \pm 0.10

The values are Means \pm SEM

B. STUDIES ON THE PERFUSED RAT HIND-LIMB

3.2. EFFLUX OF AMINO ACIDS FROM THE RAT HIND-LIMB

The rat hind-limbs were perfused with standard perfusion medium (glucose, 5.5 mM; pyruvate, 0.15 mM) containing erythrocytes. The efflux of amino acids is shown in Table 14. The efflux of amino acids observed in the present study was similar to those observed by Ward et al. (1982) and Vernon (1977). There was a large efflux of glutamine, alanine and glycine. Glycine was the third most abundant of the amino acids released (Table 14). The data of other workers (Ruderman and Berger, 1974; Felig et al., 1970; Felig and Wahren, 1971; Ward et al., 1976; Vernon, 1977; Pozefsky et al., 1969; London and Foley, 1965) (for details see section 1.2. & Table 1) also show that after alanine and glutamine, glycine is the third most important loss of amino nitrogen. In the present study there was a efflux of 28.4 μmol glycine/3 h/30 g muscle, which forms 11.7% of the total amino acid efflux. This value is in good agreement with the previous values obtained by Ward (1976) (11.3%) and Vernon (1977) (12.4%). The origin of this glycine could be the proteolysis of muscle protein, degradation of bovine serum albumin by the muscle, 'leaching out' of intracellular glycine, the degradation of muscle and erythrocyte glutathione or *de novo* synthesis. These possibilities were examined.

Table 14. Efflux of amino acids from the rat hind-limb

	Amino acid efflux ($\mu\text{mol}/3\text{h}/30\text{g}$) (MEANS \pm SEM,n=3)	Per cent of total output
Asp	1.44 \pm 0.24	0.59
Thr	16.38 \pm 0.69	6.76
Ser	16.54 \pm 0.95	6.83
Glu	*	-
Gln	63.69 \pm 3.15	26.29
Gly	28.37 \pm 1.8	11.71
Ala	42.89 \pm 3.4	17.71
Val	10.06 \pm 0.55	4.15
Ile	4.26 \pm 0.16	1.76
Leu	10.27 \pm 0.2	4.24
Tyr	4.9 \pm 0.53	2.02
Phe	6.09 \pm 0.53	2.51
Lys	21.64 \pm 1.94	8.93
His	7.21 \pm 0.37	2.98
Arg	8.49 \pm 0.14	3.50

* In two perfusions an uptake of glutamate (0.51 & 0.025 $\mu\text{mol}/3\text{ h}/30\text{ g}$ muscle) and in the third perfusion a release of 0.13 $\mu\text{mol}/3\text{ h}/30\text{ g}$ muscle was observed.

3.3. ORIGIN OF GLYCINE IN THE PERFUSED RAT HIND-LIMB

3.3.a. Hydrolysis of bovine serum albumin (BSA) and intracellular protein ?

Muscle is known to be a site of albumin degradation (Yedgar et al., 1983). Tyrosine is not metabolised by the muscle and its release can be used as an index of the proteolysis taking place in muscle. The amino acid composition of BSA (Table 15) shows that the glycine to tyrosine ratio is almost 1 : 1 ($234 \pm 12.3(3) : 266 \pm 7.8(3)$ $\mu\text{mol/g}$). Mixed muscle protein was shown to have a higher glycine to tyrosine ratio of 3.29 : 1 ($431 \pm 15.4(6) : 131 \pm 3.5(6)$ $\mu\text{mol/g}$ trichloroacetic acid precipitate, Table 16). The total tyrosine released into the perfusate was 4.9 ± 0.12 $\mu\text{mol/3 h/30 g}$ muscle (Table 14). Assuming all this resulted from mixed muscle protein and not the albumin and that no tyrosine was synthesised or degraded (Goldberg and Odessey, 1972; Teanne and Goldberg, 1976) then the maximum amount of glycine that is likely to have originated from proteolysis was 16.1 $\mu\text{mol/3 h/30 g}$ muscle (tyrosine efflux, 4.9 $\mu\text{mol/3 h/30 g}$ muscle \times glycine to tyrosine ratio in muscle protein, 3.29).

3.3.b. Intracellular amino acid concentrations in rat hind-limb muscle

The intracellular amino acid pool of muscle glycine is sufficient to give rise to the glycine efflux observed in

Table 15. Amino acid composition of bovine serum albumin,
BSA (fraction V)

	<u>$\mu\text{mol/g BSA}$</u>
Asp	800.8 (799.6,802.1)
Thr	419.3 \pm 3.0
Ser	334.1 \pm 4.33
Glu	1166.4 \pm 33.9
Gly	234 \pm 12.29
Ala	632.8 \pm 38.6
Val	481.7 \pm 25.06
Cys	219.5 \pm 10.9
Met	50.87 \pm 4.35
Ile	177.27 \pm 7.06
Leu	883.17 \pm 12.45
Tyr	266 \pm 7.77
Phe	358.23 \pm 41.23
Lys	818.43 \pm 41.23
His	196.07 \pm 4.6
Arg	289.73 \pm 14.21
Pro	382.67 \pm 43.01

Values are Means \pm SEM (n=3, except for asp)
Amino acid composition of BSA was determined as described in
section 2.12.d.

Table 16. Amino acid composition of rat hindquarter muscle protein (Means \pm SEM, n=6)

	$\mu\text{mol}/100\text{mg}$ trichloro- acetic acid precipitable protein	Amino acid to tyrosine ratio
Asp	36.09 \pm 11.93	2.75
Thr	21.41 \pm 0.83	1.63
Ser	25.33 \pm 1.35	1.93
Glu*	43.91	3.35
Gln*	24.77	1.89
Gly	43.12 \pm 1.54	3.29
Ala	39.68 \pm 0.97	3.02
Val	27.68 \pm 0.87	2.11
Cys	2.26 \pm 0.13	0.17
Met	8.59 \pm 0.36	0.65
Ile	24.72 \pm 0.94	1.88
Leu	43.59 \pm 1.32	3.32
Tyr	13.12 \pm 0.35	1.00
Phe	16.19 \pm 0.42	1.23
Lys	39.84 \pm 0.51	3.04
His	8.60 \pm 0.18	0.65
Arg	18.74 \pm 0.28	1.43

Amino acid composition of hindquarter muscle was determined as described in section 2.12.d.

* Glu + Gln was 68.69 \pm 1.6 $\mu\text{mol}/100\text{mg}$ trichloroacetic acid precipitable protein. Gln to glu ratio in a theoretical protein containing actin and myosin in the proportion they exist in skeletal muscle is 1:1.77 (Ruderman and Lund, 1972).

the perfusate. Intracellular amino acid concentrations in fresh and perfused muscle are presented in Table 17. This table also gives intracellular amino acid concentrations when the perfusion medium contained serine and 5-formyl tetrahydrofolate, an inhibitor of serine hydroxymethyltransferase, which will be discussed in detail in the following sections (sections 3.4.b. and 3.4.c.). There was no significant change in the concentration of intracellular glycine following the perfusion with standard perfusion medium but a significant ($P < 0.05$) decrease in the intracellular concentration of serine, a possible precursor of glycine, was observed. Similar observations have been made recently by Kadowaki *et al.* (1984). For calculation of the intracellular amino acid concentration *in vivo* the extracellular space was taken as 0.17 ml/g (Waterlow and Stephen, 1968; Hider *et al.*, 1971) and the amino acid composition of plasma was as given in Table 18. The values obtained for amino acids in plasma were in close agreement with those of Ward (1976), Vernon (1976) and Ebisawa *et al.* (1983). The intracellular amino acid concentrations in the perfused muscle were determined by taking the extracellular space as 0.15 ml/g (average of the values obtained by Ward (1976) and Vernon (1977); 0.14 ml/g and 0.16 ml/g respectively) and the free amino acid composition of the perfusate at 3 h. These data do not suggest that the glycine efflux is due to changes in intracellular glycine concentration.

Table 17. Intracellular amino acid concentrations in rat hind-limb muscle *in vivo* and in muscle perfused under different conditions (Mean values with pooled standard error of the difference by analysis of variance, n=3)

	umol/g muscle				SED	Significance of comparison (P values)		
	<i>In vivo</i>	Muscle perfused with				avb	bvc	cvd
(a)	SPM	SPM + 0.2mM serine	SPM + 0.2mM serine + 2.5mM 5-CHO-THF	(d)				
Asp	0.398	0.116	0.133	0.144	0.0466	<0.01	n.s	n.s
Thr	0.756	0.50	0.404	0.463	0.068	<0.02	n.s	n.s
Ser*	1.373	0.854	1.405	1.43	0.18	<0.05	<0.05	n.s
Glu	0.815	0.359	0.452	0.33	0.056	<0.01	n.s	n.s
Gln	4.60	2.57	2.48	2.41	1.5	<0.02	n.s	n.s
Gly	5.69	5.38	5.49	5.76	0.35	n.s	n.s	n.s
Ala	2.60	2.79	2.55	2.88	0.38	n.s	n.s	n.s
Val	0.164	0.151	0.155	0.141	0.041	n.s	n.s	n.s
Ile	0.052	0.097	0.087	0.095	0.011	<0.02	n.s	n.s
Leu	0.1125	0.221	0.213	0.209	0.036	<0.05	n.s	n.s
Tyr	0.068	0.083	0.068	0.08	0.011	n.s	n.s	n.s
Phe	0.084	0.1	0.069	0.10	0.014	n.s	n.s	n.s
Lys**	0.766	0.50	0.60	0.94	0.137	n.s	n.s	n.s
His	0.28	0.256	0.259	0.277	0.034	n.s	n.s	n.s
Arg	0.376	0.285	0.213	0.289	0.068	n.s	n.s	n.s

SPM, Standard perfusion medium; n.s, not significant; * avc, n.s; avd, n.s; ** bvd, P<0.05
 Intracellular amino acid concentrations in hind-limb muscle were determined as described in section 2.13.

Table 18. Amino acid concentrations in rat plasma

Amino acid	Concentration ($\mu\text{mol}/100\text{ml}$)
Asp	2.39 ± 0.07
Thr	24.81 ± 0.49
ser	22.72 ± 1.0
glu	19.99 ± 0.72
gln	41.92 ± 0.91
Pro	15.38 ± 0.30
Gly	37.95 ± 1.57
Ala	41.85 ± 1.25
Val	15.90 ± 0.56
Cys	5.58 ± 0.28
Met	3.76 ± 0.27
Ile	8.51 ± 0.51
Leu	12.53 ± 0.57
Tyr	6.05 ± 0.19
Phe	5.29 ± 0.26
Lys	31.75 ± 1.24
His	6.17 ± 0.15
Arg	13.5 ± 0.36

Values are Means \pm SEM (n=4)

Amino acid concentrations in rat plasma were determined by the method described in section 2.12.a.

3.3.c. Muscle and erythrocyte glutathione content

The degradation of glutathione (γ -glutamyl-cysteinyl-glycine) during perfusion could contribute to glycine in the medium. The enzymes catalysing the reactions are transpeptidase and dipeptidase (Griffith and Meister, 1979). Both muscle and erythrocytes contain glutathione. Both the reduced and the oxidised glutathione content of muscle and erythrocytes were measured before and after the perfusion. The results are shown in Table 19. There was no significant change in the content of either reduced or oxidised glutathione in muscle and erythrocytes before and after the perfusion. This suggests that neither muscle nor erythrocyte glutathione contributes significantly to the glycine efflux.

3.3.d. De novo synthesis of glycine

From above it appears that the intracellular glycine pool, the breakdown of muscle and erythrocyte glutathione and proteolysis cannot collectively account fully for the efflux of glycine observed. The maximum amount of glycine that could come from proteolysis of intracellular proteins and BSA was $16.1 \mu\text{mol}/3 \text{ h}$. Therefore, the minimum amount of *de novo* glycine synthesis by the rat hind-limb was $12.27 \mu\text{mol}/3 \text{ h}/30 \text{ g}$ muscle (i.e. the total glycine efflux, $28.37 \mu\text{mol}/3 \text{ h}/30 \text{ g}$ muscle minus the glycine released due to proteolysis, $16.10 \mu\text{mol}/3 \text{ h}$).

The studies described above suggest that the rat hind-limb synthesises glycine and the synthesis is at least $12.3 \mu\text{mol}/3 \text{ h}/30 \text{ g}$ muscle. Glycine synthesis from serine was

Table 19. Glutathione concentration in rat hind-limb muscle and erythrocytes before and after perfusion
(Means \pm SEM, n = 3)

	<u>Muscle</u>		<u>Erythrocytes</u>	
	nmol/g wet wt.		nmol/ml perfusion medium	
	<i>in vivo</i>	Perfused	Before perfusion	After perfusion
Reduced	812 \pm 38.9	801 \pm 74	199 \pm 6.65	207 \pm 7.6
Oxidised	70.0 \pm 15.4	79 \pm 15.8	126 \pm 12.4	130 \pm 3.2

The values are not significantly different (P > 0.05)

studied as some evidence is available which show that serine could be a precursor of glycine in muscle (see section 1.5.a.). The experiments were carried out by adding serine, 5-formyl tetrahydrofolate, a specific inhibitor of serine hydroxymethyltransferase (EC 2.1.2.1) or radioactive serine to the perfusion medium. The results obtained are presented below.

3.4. SYNTHESIS OF GLYCINE FROM SERINE

3.4.a. Perfusions using the standard perfusion medium (SPM)

Using the SPM, the glycine efflux was 28.37 ± 1.8 $\mu\text{mol}/3 \text{ h}/30 \text{ g}$ muscle (Table 20). After an initial rapid efflux glycine release from the perfused hind-limb proceeded at a steady rate. Rates of glycine production were assessed from first order portion of the graph. In most cases, the efflux between 0 and 50 min was atypical, presumably reflecting the adjustment of the muscle to the perfusion system. The rate of glycine efflux was 8.74 ± 0.26 $\mu\text{mol}/\text{h}/30 \text{ g}$ muscle (Fig.16 & Table 21). Under these conditions of perfusion, as mentioned earlier (section 3.3.b.) no change in muscle intracellular concentration of glycine was found; however, there was a significant decrease in muscle intracellular serine concentration (Table 17). The minimum amount of *de novo* glycine synthesis on using SPM was 12.3 $\mu\text{mol}/3 \text{ h}/30 \text{ g}$ muscle (see section 3.3.d.).

Table 20. Effects of the addition of serine and 5-formyl tetrahydrofolate (5-CHO-THF) to the standard perfusion medium (SPM) on the efflux of amino acids from the perfused rat hind-limb (Mean values with pooled standard error of the difference by analysis of variance, n=3)

	<u>μmol/3h/30g muscle</u>				SED
	<u>Muscle perfused with</u>				
	SPM (a)	SPM + 5mM serine after 75 min (b)	SPM + 0.2mM serine (c)	SPM + 0.2mM serine +2.5mM 5-CHO-THF (d)	
Asp	1.44	1.37	1.53	1.64	0.32
Thr	16.38	*	16.9	16.89	1.52
Gly	28.37	36.78	37.84	31.83	1.98
Ala	42.89	44.44	46.92	41.99	3.49
Val	10.06	10.95	11.42	9.85	0.82
Cys	1.80	1.80	1.88	1.74	0.06
Met	2.27	2.04	2.52	2.53	0.22
Ile	4.26	4.38	4.59	4.18	0.65
Leu	10.27	9.9	10.77	9.61	0.75
Tyr	4.90	5.18	5.0	4.90	0.4
Phe	6.09	6.09	6.73	6.11	0.60
Lys	21.64	19.64	21.28	-	2.48
His	7.21	7.59	7.25	-	0.54
Arg	8.49	8.44	8.50	-	0.47

*, could not be determined as ser peak overlapped thr
The difference between the groups was insignificant for all the amino acids except gly (avb, P<0.02; avc, P<0.01; cvd, P<0.05)

3.4.b. Effect of addition of serine to the standard perfusion medium

Addition of 0.2 mM serine from start of the perfusion stimulated ($P < 0.01$) the rate of glycine efflux to $13.6 \pm 0.83 \mu\text{mol/h/30 g muscle}$, an increase of 55% (without serine: $8.74 \pm 0.26 \mu\text{mol/h/30 g muscle}$) (Fig.16 & Table 21), and the total efflux of glycine was $37.84 \pm 1.4 \mu\text{mol/3 h/30 g muscle}$ (without serine: $28.37 \pm 1.8 \mu\text{mol/3 h/30 g muscle}$, $P < 0.01$, Table 20). The minimum amount of glycine synthesised in the muscle when perfusions were carried out with 0.2 mM serine was $21.39 \mu\text{mol/3 h/30 g muscle}$ (i.e. total glycine released, $37.84 \mu\text{mol/3 h/30 g muscle}$ (Table 20) minus glycine released due to proteolysis, $5.0 \times 3.29 = 16.45 \mu\text{mol/3 h/30 g muscle}$ (Table 16 & 20)), approximately 1.7 times than that obtained with the SPM alone. Addition of serine (5 mM) after 75 min from the start also increased ($P < 0.01$) the rate of glycine production to $14.94 \pm 1.07 \mu\text{mol/h/30 g muscle}$, an increase of about 71% (without serine: $8.74 \pm 0.26 \mu\text{mol/h/30 g muscle}$) (Fig. 16 & Table 21). The total production of glycine ($36.78 \pm 0.57 \mu\text{mol/3 h/30 g muscle}$) also increased significantly ($P < 0.02$) (Table 20). The efflux of tyrosine or any other amino acid was not influenced by the treatments (Table 20). Also there was no difference in the muscle intracellular concentration of glycine and serine between the fresh muscle and the perfused muscle following perfusion with 0.2 mM serine or 5 mM serine after 75 min (Table 17). It may be noted from the above section and table 17 that there was a significant

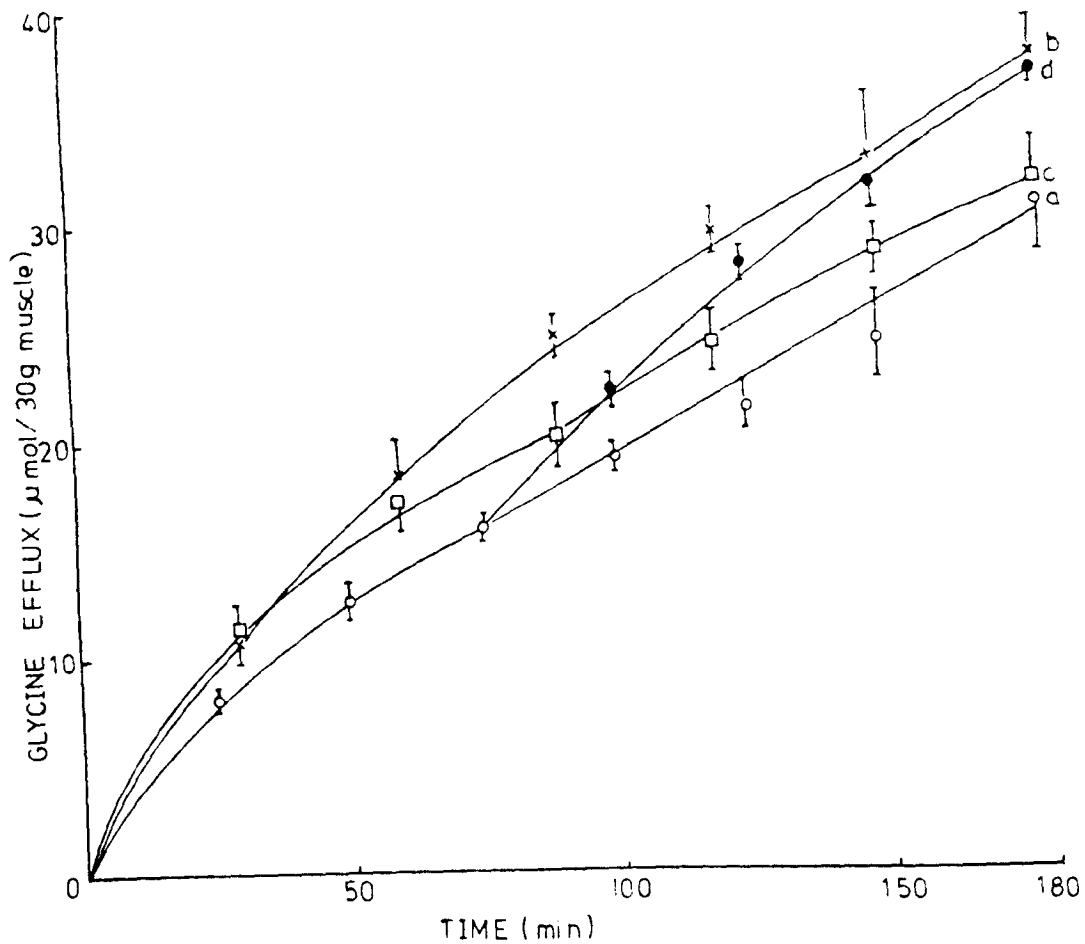

Fig. 16 Time course of glycine efflux from the perfused rat hind-limb

(o — o , standard perfusion medium, SPM; x — x , SPM + 0.2mM serine; □ — □ , SPM + 0.2mM serine + inhibitor (2.5mM); ● — ● , SPM + 5mM serine after 75 min; a v b, $P < 0.02$; b v c, $P < 0.05$; a v d, $P < 0.02$; a,b,c,d values at 3h)

decrease in muscle intracellular serine concentration following perfusion with the medium free of serine. Addition of serine in the perfusion medium maintained the intracellular concentration of serine to nearly that *in vivo*. The above observations suggest the synthesis of glycine from serine in the muscle. In addition, there was no significant difference ($P > 0.05$) between the intracellular concentration of any other amino acid when perfusions were carried out with or without added serine (Table 17; b v c or c v d, n.s).

3.4.c. Effect of addition of 5-formyl tetrahydrofolate to the standard perfusion medium containing 0.2 mM serine

On adding 5-formyl tetrahydrofolate (2.5 mM), a specific inhibitor of serine hydroxymethyltransferase (EC 2.1.2.1) to the SPM containing 0.2 mM serine, the rate of glycine efflux decreased to $8.68 \pm 0.47 \mu\text{mol/h/30 g muscle}$, a drop of 36% on that observed when the inhibitor was not present (Table 21). The total efflux of glycine decreased from $37.84 \pm 1.4 \mu\text{mol/3 h/30 g muscle}$ to $31.83 \pm 1.5 \mu\text{mol/3 h/30 g muscle}$ ($P < 0.05$) (Table 20), a decline of 16%, whereas the glycine synthesis decreased from $21.39 \mu\text{mol/3 h/30 g muscle}$ to $15.73 \mu\text{mol/3 h/30 g muscle}$, a decrease of about 28% (i.e. total glycine released, $31.83 \mu\text{mol/3 h/30 g muscle}$ (Table 20) minus glycine released due to proteolysis, $4.9 \times 3.92 = 16.1 \mu\text{mol/3 h/30 g muscle}$ (Table 16 & 20)). There was no change ($P > 0.05$) in the efflux of any other amino acid in response to the treatment (Table 20). None of the above treatments had any effect on

Table 21. Rates of glycine and tyrosine efflux ($\mu\text{mol/h/30 g}$ muscle) from the perfused rat hind-limb under different conditions of perfusion (mean values with pooled standard error (SED) of the difference by analysis of variance, $n=3$)

	SPM	SPM +0.2mM serine	SPM +0.2mM serine +inhi- bitor	SPM +5mM serine after 75min	SED	Significance of comparison		
	(a)	(b)	(c)	(d)		avb	bvc	avd
Glycine	8.74	13.60	8.68	14.94	1.03	**	**	**
Tyrosine	1.62	1.46	1.80	1.72	0.22	ns	ns	ns

**, $P < 0.01$; ns, not significantly different

SPM, Standard perfusion medium

Inhibitor, 5-formyl tetrahydrofolate

Rates of metabolite production were assessed from first order portion of the graph (1-2.5 h). In most cases the efflux between 0 and 50 min were atypical, presumably reflecting the adjustment of the muscle to the perfusion system.

the total tyrosine efflux or the rate of tyrosine efflux (Table 20 & 21) suggesting that protein catabolism was not affected by them. A slight though insignificant increase in the intracellular serine concentration was found when the inhibitor was used (Table 17). The inhibitor did not significantly change the intracellular concentration of any other amino acid studied (Table 17; *c v d*, n.s.).

3.5. INCORPORATION OF ^{14}C INTO AMINO ACIDS FROM (U- ^{14}C) GLUCOSE

Rat hind-limbs were perfused with the standard perfusion medium containing (U- ^{14}C)glucose (0.2 $\mu\text{Ci/ml}$, 5.5 mM). The radioactivity was recovered in alanine, glutamate + glutamine, serine and glycine. The specific activity was in the order alanine > serine > glutamate + glutamine > glycine (Table 22). No radioactivity was detected in any other amino acid except that there was some indication of labelling aspartic acid. But this could not be measured as the peak was not very distinct. A number of other acidic and non-charged products of glucose metabolism eluted from the column near the aspartic acid peak, giving high counts at the base of the peak. When the rat diaphragm was incubated with labelled glucose it synthesised labelled glutamate, glutamine, alanine and aspartate (Manchester and Young, 1959; Odessey *et al.*, 1974). Based on the specific activity of precursor glucose at time 'zero' and that of alanine in the medium after 3 h of perfusion, it was found that 25% of alanine-C released by the perfused hind-limb is

Table 22. Incorporation of ^{14}C into amino acids from
 (U- ^{14}C)glucose (0.2 $\mu\text{Ci/ml}$, 5.5 mM)* in the
 perfused rat hind-limb

Amino acids	Specific activity** (10^3 dpm/ $\mu\text{mol-C}$)
Alanine	3.31 \pm 0.20 (5)
Glutamine and glutamic acid	0.49 \pm 0.034 (5)
Serine	1.35 \pm 0.14 (6)
Glycine	0.12 \pm 0.027 (4)

Values are Means \pm SEM with the number of observations in parentheses

* Specific activity of (U- ^{14}C)glucose, 13.3×10^3 dpm/ $\mu\text{mol-C}$

** Assuming all carbons equally labelled

derived from exogenous glucose (method of calculation was that of Odessey et al., 1974). This represents the minimal value as it includes the unlabelled alanine present initially in the intracellular pool. It is interesting to note the labelling of serine and glycine from labelled glucose, suggesting that the pathway exists in muscle for the synthesis of serine and glycine from glucose, and glucose or muscle glycogen could be a source of serine and glycine released by the muscle.

3.6. INCORPORATION OF ^{14}C INTO AMINO ACIDS FROM (U- ^{14}C)SERINE AND (3- ^{14}C) SERINE

The rat hind-limbs were perfused with (U- ^{14}C)serine and (3- ^{14}C)serine (both used at 0.1 $\mu\text{Ci/ml}$, 0.2 mM).

3.6.a. Specific activities of the labelled amino acids

The radioactivity from (U- ^{14}C)serine was recovered in glycine, methionine, aspartate, glutamate + glutamine, alanine and cystine. When (3- ^{14}C)serine was used no radioactivity was incorporated into glycine. However, the radioactivity was incorporated into methionine, aspartate, glutamate + glutamine, alanine and cystine (Table 23). The specific activity of methionine recovered using (3- ^{14}C)serine was about 3 times higher than that obtained with (U- ^{14}C)serine. These data give confidence that the muscle is able to activate 3-C of serine to 'one-carbon' units. The rest of the carbons of methionine can not be synthesised by animals and it is difficult to see how these carbons could be labelled by exchange reactions.

Table 23. Production of radiolabelled amino acids from (U-¹⁴C)serine and (3-¹⁴C)serine (both used at 0.1 μ Ci/ml, 0.2 mM) in the perfused rat hind-limb

Amino acids	Specific activity (10^3 dpm/ μ mol)	
	(U- ¹⁴ C)serine	(3- ¹⁴ C)serine
Glycine	38.13 \pm 3.59(3)	n.d
Methionine	14.95 \pm 0.98(3)***	42.55 \pm 0.67(5)
Alanine	1.33 (1.29, 1.37)	1.12 (1.24, 1.0)
Aspartate	25.30 (24.0, 26.6)	18.41 \pm 1.72(3)
Glutamate + glutamine	1.06 (1.6, 1.12)	0.87 (0.89, 0.85)
Cystine	14.98 (10.7, 19.25)	8.86 \pm 0.96(3)

*** P < 0.001

n.d, not detected (limit of detection 0.2×10^3 dpm/ μ mol)
 Values in parentheses show numbers of observations

3.6.b. Time course of glycine and serine radioactivity in the medium

The radioactivity of (U- 14 C)serine in the perfusate dropped rapidly during the first hour and a smaller decline was noted during the next two hours. The decrease in the first hour was about 71% of the initial serine radioactivity, whereas in the next 2 h it was only 17%. After 3 h of perfusion the radioactivity recovered in serine was only 12% of the initial serine radioactivity. A similar pattern was observed for the decrease of (3- 14 C)serine radioactivity. Incorporation of label from (U- 14 C)serine into glycine had a similar pattern. About 6% of the initial serine activity was found in glycine in the medium after 3 h of perfusion (Fig. 17).

3.6.c. Distribution of glycine and serine radioactivity

The distribution of glycine and serine radioactivity in the perfusion medium (PM), muscle free amino acid pool (MFAAP) and the muscle bound amino acids (MBAA) was examined after 3 h of perfusion using (U- 14 C)serine. The results are shown in Table 24. A total of 22% of the initial serine radioactivity was recovered in glycine. About 27%, 64% and 9% of this total glycine radioactivity was in the PM, MFAAP and MBAA respectively. Total serine left in the system (PM, MFAAP and MBAA) was 35% of the initial serine radioactivity added. Its distribution between the PM, MFAAP and MBAA was 31, 51 and 11% respectively.

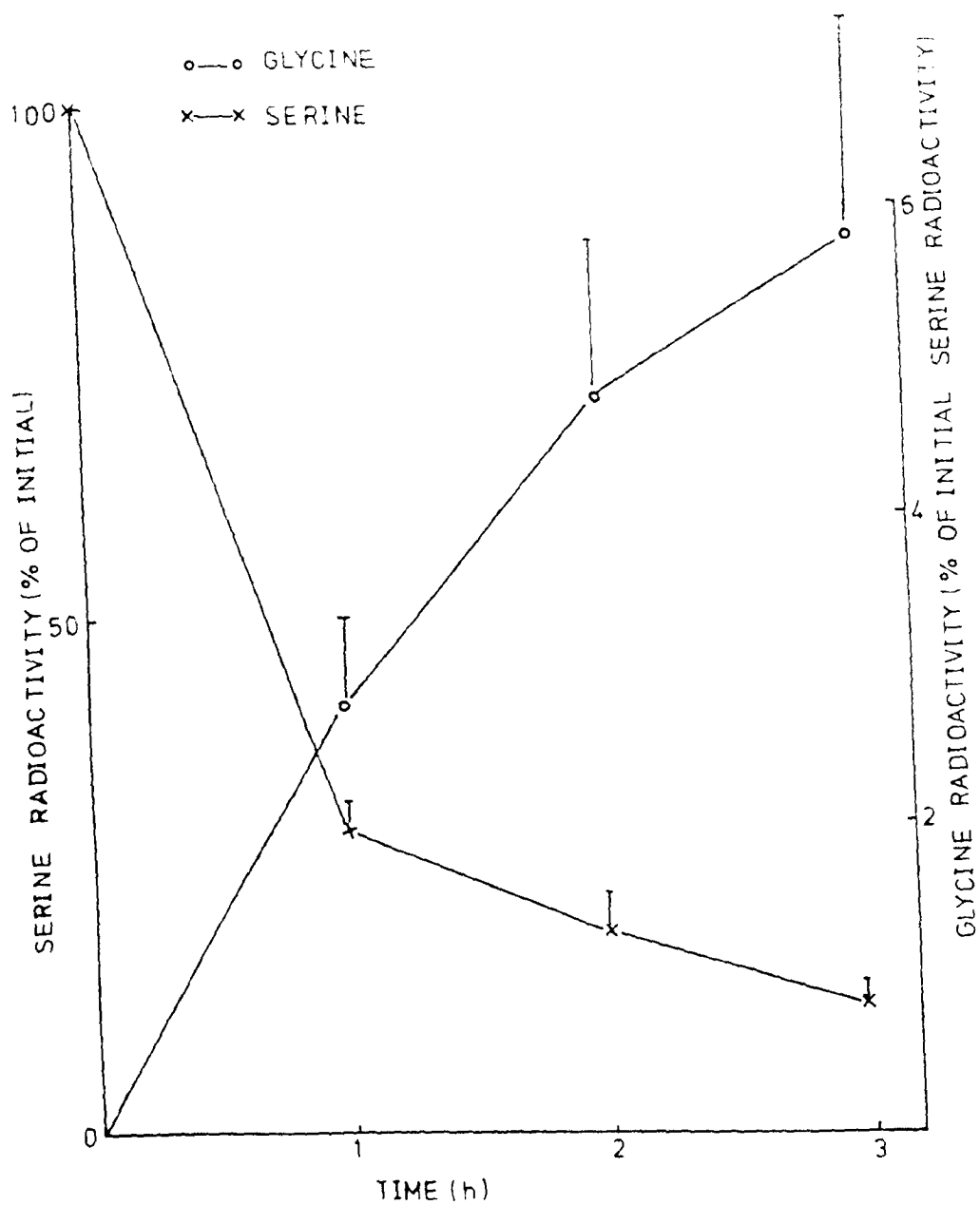

Fig. 17 Time course of serine and glycine radioactivity in the medium

Table 24. Distribution of glycine and serine radioactivity in the perfusion medium, muscle free amino acid pool and muscle protein-bound amino acids following perfusion of the rat hind-limb using (U-¹⁴C)serine (0.1 μ Ci/ml, 0.2 mM)

	<u>% of initial serine radioactivity</u>			
	Perfusion medium	Muscle free amino acid pool	Muscle protein amino acid	Total
Glycine	5.75 \pm 1.44(3)	13.60 \pm 2.60(3)	1.81 \pm 1.06(3)	21.60 \pm 5.09(3)
Serine	13.23 \pm 2.12(3)	17.92 \pm 5.40(3)	3.86 \pm 1.30(3)	34.96 \pm 4.80(3)

(Samples were prepared for determination of radioactivity in perfusate, muscle free amino acids and muscle-bound amino acids as described in section 2.14.c.)

3.6.d. Specific activities of glycine and serine in the medium

Table 25 shows the specific activities of labelled glycine synthesised from (U- 14 C)serine and that of added (U- 14 C)serine and (3- 14 C)serine at 60, 120 and 180 min of perfusion. The specific activity of labelled glycine was same at 1, 2 or 3 h of perfusion. However, the specific activities of both the serine decreased as the perfusion time increased. There were drops of about 87 and 78% respectively in the specific activities of (U- 14 C)serine and (3- 14 C)serine in the medium during 3 h of perfusion (Fig. 18). The results suggest that besides conversion of serine to glycine there could be a synthesis of serine in the perfused rat hind-limb. The synthesis of serine could be from glucose or muscle glycogen as shown in section 3.5. The decrease in specific activity of serine could also be due to serine coming from proteolysis of muscle protein or the albumin.

3.6.e. Amount of glycine derived from serine in the perfused rat hind-limb

The per cent of glycine derived from serine was calculated from the specific activity of glycine and (U- 14 C)serine at 1, 2 and 3 h in the medium (Table 25) using the following formula. It has been assumed that the synthesis of glycine from serine in muscle is taking place by only serine hydroxymethyltransferase.

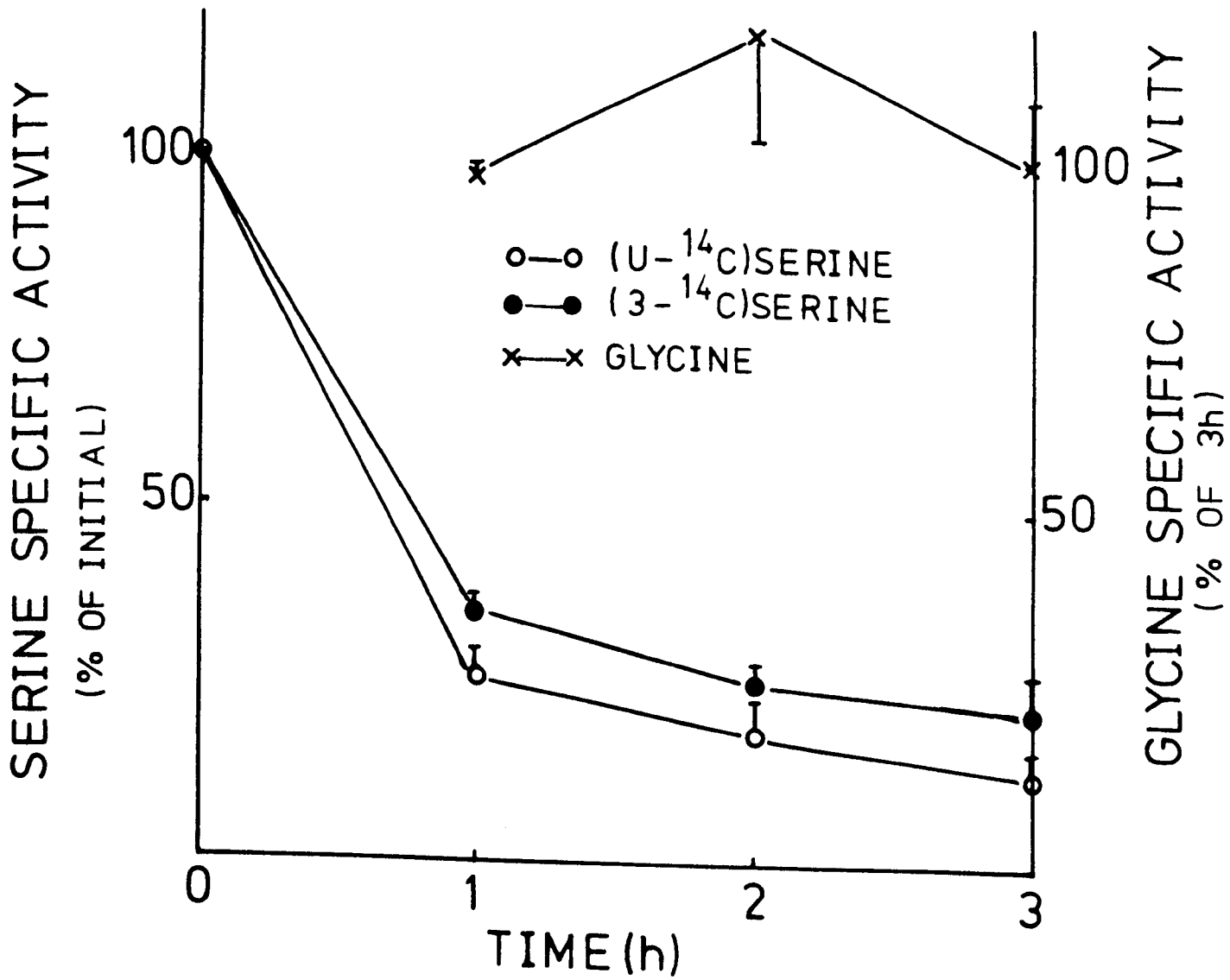

Fig. 18 Specific activities of glycine and serine in the medium

Table 25. Specific activities of labelled glycine, (U-¹⁴C)serine and (3-¹⁴C)serine in the medium during perfusion of the rat hind-limb

		<u>Specific activity (10³ dpm/μmol)</u>			
		0*	1h	2h	3h
Labelled glycine	0		37.36 ± 0.26(3)	45.14 ± 5.80(3)	38.12 ± 3.59(3)
(U- ¹⁴ C)serine	1100		291.02 ± 38.16(3)	194.18 ± 58.58(3)	144.17 ± 39.29(3)
(3- ¹⁴ C)serine	1100		384.03 ±30.14(3)	277.60 ±36.19	244.04 ±58.50(3)

* 10 min after the addition of radiochemical (see section 2.7.)

Per cent of glycine derived =

$$\left(\frac{\text{glycine specific activity at a particular time}}{\text{serine specific activity at that time}} \right) \times \left(\frac{3}{2} \right)^* \times 100$$

* 1 mole each of serine and glycine has 3 and 2 carbons respectively.

Per cent glycine derived from serine:

- i) using the data at time 1 h = 19.3%
- ii) using the data at time 2 h = 34.9%
- iii) using the data at time 3 h = 39.7%

As mentioned earlier (section 3.4. & Table 21) the efflux of glycine from rat hind-limbs between 0 and 50 min of perfusion was atypical, presumably because the muscle was adjusting to the perfusion system. So, the value obtained using the data at 1 h may not represent the actual value. Therefore, upto 40% of glycine appears to be derived from serine.

If the synthesis of glycine from serine is also taking place by glycine synthase, 3-C of serine would be transferred to 2-C of glycine, and therefore the above value obtained would be an overestimate of glycine derived from serine. However, the results of the present study show that glycine is synthesised in rat hind-limb by serine hydroxymethyltransferase and not by glycine synthase (see section 3.8. & 4.5.).

3.7. EFFECT OF BRANCHED-CHAIN KETO ACIDS (BCKAs) ON GLYCINE SYNTHASE IN THE PERFUSED RAT HIND-LIMB

The BCKAs (α -ketoisovaleric acid, α -keto- β -methylvaleric acid and α -ketoisocaproic acid) are known to increase the activity of glycine synthase in rat liver (O'Brien, 1978). Previously it has been shown that glycine was not labelled from (3- 14 C)serine (section 3.6.a.). The label from 3-C of serine is transferred to glycine by glycine synthase (see section 1.5.a.). Keeping in mind the observation of O'Brien (1978), rat hind-limbs were perfused with the standard perfusion medium containing both (3- 14 C)serine (0.1 μ Ci/ml, 0.2 mM serine) and BCKAs (3 mM each). Once more, glycine was not labelled from (3- 14 C)serine in the presence of BCKAs suggesting that glycine synthase was still not active. The specific activity of methionine in the perfusion medium both in presence and absence of BCKAs is shown in Table 26. There was no significant difference in the specific activity of methionine. The label incorporated would only be expected to be on the methyl group of methionine. These observations suggest that the muscle has the activity to convert 3-C of serine to active 'one-carbon' units, again giving confidence that glycine synthase was not active.

Table 26. Specific activity of methionine following perfusion of the rat hind-limb in absence and presence of branched-chain keto acids (BCKAs)

	<u>Specific activity (10^3 dpm/μmol)</u>		Significance of comparison
	<u>Perfused with</u>		
	SPM+(3- 14 C) serine* (n=5)	SPM+(3- 14 C) serine* +BCKAs (n=3)	
Glycine	n.d	n.d	-
Methionine	42.55 \pm 6.70	36.31 \pm 0.32	n.s

SPM, Standard perfusion medium; n.d, not detected (limit of detection 0.2×10^3 dpm/ μ mol); n.s, not significant
 * used at 0.1μ Ci/ml (0.2 mM)
 BCKAs used were α -ketoisovaleric acid, α -keto- β -methylvaleric acid and α -ketoisocaproic acid (3 mM each)

3.8. LABELLING OF C-1 AND C-2 OF GLYCINE

Following perfusion with (U-¹⁴C)serine, samples of the perfusate were subjected to preparative ion-exchange chromatography and glycine isolated (see section 2.16.). The radioactivity in C-1 and C-2 of glycine was determined (sections 2.16 & 2.17). The radioactivity in C-1 and C-2 of glycine was almost equal (Table 27). This indicates that serine hydroxymethyltransferase is the most likely pathway for conversion of serine to glycine. This will be discussed further in section 4.5.

3.9. SYNTHESIS OF GLYCINE FROM THREONINE

In rat about 20-33% of dietary threonine is degraded to glycine (Meltzer and Sprinson, 1952; Bird and Nunn, 1983). Perfusions were carried out using (U-¹⁴C)threonine (0.1 μ Ci/ml, 0.2 mM) and incorporation of label into glycine was studied. The concentration of threonine (0.2 mM) in the medium was chosen because of two reasons : i) it is near to *in vivo* plasma concentration of threonine (Table 18) and ii) it made possible studies of the comparative effectiveness of serine and threonine as substrates for glycine synthesis (the concentration of serine in the medium was also 0.2 mM, near the *in vivo* concentration in plasma (Table 18)).

Table 27. Radioactivity in C-1 and C-2 of labelled glycine isolated following perfusion of the rat hind-limb with (U-¹⁴C)serine

	Radioactivity in C-1 (% of total)	Radioactivity in C-2 (% of total)
Perfusion I	47.70 ± 1.40(3)	48.47 ± 1.31(3)
Perfusion II	45.40 ± 3.77(3)	49.90 ± 0.26(3)
Perfusion III	44.30 ± 1.86(3)	49.10 ± 0.20(3)
Mean	45.80 ± 1.00(3)	49.16 ± 0.44(3)

Radioactivity in C-1 of glycine was determined by the method of Rowsell et al. (1975) and in C-2 by the method developed by the author (see section 2.17.)

3.9.a. Incorporation of ^{14}C into glycine from (U- ^{14}C)threonine

Labelled glycine was recovered on using (U- ^{14}C)threonine suggesting that threonine is converted to glycine in the perfused hind-limb. However, the conversion appears to be very small. The specific activity of glycine in the medium after 3 h was $298 \pm 28.9(3)$ dpm/ μmol which was about 100 times less than that obtained using (U- ^{14}C)serine (Table 27).

From the specific activity of radioactive glycine and (U- ^{14}C)threonine in the perfusion medium at 3 h, it is calculated that about 0.16% of glycine-C [(specific activity of glycine in dpm/ μmol -C divided by specific activity of (U- ^{14}C)threonine in dpm/ μmol -C) \times 100] originated from threonine. However, it must be noted that it is an approximate value, as specific activity of the precursor decreased by about 65% in 3 h (specific activity: at time 0, 2.75×10^5 dpm/ μmol -C; at 3 h, 0.95×10^5 dpm/ μmol -C).

3.9.b. Distribution of glycine and threonine radioactivity

Table 28 shows the distribution of glycine and threonine radioactivity in the perfusion medium (PM), muscle free amino acid pool (MFAAP) and muscle bound amino acids (MBAA) after 3 h of perfusion using (U- ^{14}C)threonine (0.1 $\mu\text{Ci}/\text{ml}$, 0.2 mM). A total of only 0.11% of the initial threonine radioactivity was found in glycine. Of this total 0.04% was in the PM and 0.07% in the MFAAP. About 71% of the initial

Table 2B. Distribution of glycine and threonine radioactivity in perfusion medium (PM), muscle free amino acid pool (MFAA) and muscle protein-bound amino acids (MPBAA) following perfusion of the rat hind-limb using (U-¹⁴C)threonine (0.1 μ Ci/ml, 0.2 mM)

	<u>% of initial threonine radioactivity</u>			
	PM	MFAA	MPBAA	Total
Glycine	0.04 \pm 0.003(3)	0.07 \pm 0.006(3)	0	0.11
Threonine	36.43 \pm 0.78(3)	32.67 \pm 2.31(3)	2.32 \pm 0.41(3)	71.42

(Samples were prepared for determination of radioactivity in perfusate, muscle free amino acids and muscle-bound amino acids as described in section 2.14.c.)

radioactivity was still in threonine after 3 h of perfusion. This suggests that the rest (about 29%) was metabolised in 3 h. During the same time serine was found to be metabolised to a greater extent, 65% (section 3.6.c.). This data indicates that threonine is not as actively metabolised as is serine.

3.10. EFFECT OF BRANCHED-CHAIN KETO ACIDS (BCKAs)

The rat hind-limbs were perfused with BCKAs (see section 3.7.). The main objective of this experiments was to study the effect of BCKAs on glycine synthase, which has been dealt with in section 3.7. The efflux of amino acids and the intracellular amino acid concentration was also determined as these could give valuable information on the role of amino acids in the transport of nitrogen from muscle.

3.10.a. Efflux of amino acids from the perfused rat hind-limb

The efflux of amino acids from perfused rat hind-limb is presented in Table 29. There was a significant decrease in the efflux of glutamine and alanine in presence of BCKAs in the perfusion medium. Glycine efflux decreased (25%) in presence of BCKAs in the medium but the decrease was not significant ($P > 0.1$). The efflux of all branched-chain amino acids (BCAAs) (valine, isoleucine and leucine) increased

Table 29. Effect of the addition of branched-chain keto acids (BCKAs) to the standard perfusion medium (SPM) containing 0.2 mM serine on the efflux of amino acids from the perfused rat hind-limb (Mean values with pooled standard error of the difference by analysis of variance)

	<u>μmol/3h/30 g muscle</u>		Significance of comparison
	<u>Muscle perfused with</u>		
	SPM+0.2mM serine (n=4)	SPM+0.2mM serine + BCKAs (n=3)	
Asp	1.31 ± 0.22	1.17 ± 0.32	n.s
Thr	16.37 ± 1.89	11.14 ± 0.11	n.s
Gln	34.98 ± 3.45	17.85 ± 3.34	P < 0.02
Glu	7.16 ± 1.53	7.04 ± 0.51	n.s
Gly	29.48 ± 3.61	22.25 ± 0.35	n.s
Ala	37.89 ± 4.78	12.41 ± 2.47	P < 0.001
Val	10.02 ± 0.77	28.33 ± 1.92	P < 0.001
Met	1.86 ± 0.19	1.46 ± 0.46	n.s
Ile	4.13 ± 0.44	12.87 ± 0.99	P < 0.001
Leu	8.38 ± 1.05	28.45 ± 1.85	P < 0.001
Tyr	3.66 ± 0.33	3.90 ± 0.39	n.s
Lys	-	16.10 ± 1.25	-
His	-	4.84 ± 0.75	-
Arg	-	6.46 ± 1.1	-

n.s not significant

BCKAs used were α-ketoisovaleric acid, α-keto-β-methylvaleric acid and α-ketoisocaproic acid (3 mM each)

significantly on perfusion with the medium containing BCKAs. No change in the efflux of any other amino acid was recorded (Table 29). Presumably some of the available nitrogen was being incorporated into BCAAs.

3.10.b. Intracellular amino acid concentrations in rat hind-limb muscle

The intracellular amino acid concentrations in rat hind-limb muscle perfused with and without BCKAs are shown in Table 30. The intracellular concentration of all the BCAAs (valine, isoleucine, and leucine) was significantly higher when the medium contained BCKAs. Also the intracellular concentration of glutamate increased significantly. There was no significant change in the intracellular concentration of any of the other amino acids studied (Table 30). The above observations suggest that the keto analogues of branched-chain amino acids can get converted to their corresponding amino acids. Similar observations have been made in liver and rat hind-limbs by Walser *et al.* (1973).

Table 30. Intracellular amino acid concentrations of rat hind-limb muscle *in vivo* and after perfusion with the standard perfusion medium (SPM) containing 0.2 mM serine and with the SPM containing both 0.2 mM serine and branched-chain keto acids (BCKAs) (Mean values with pooled standard error of the difference by analysis of variance, n=3)

	<u>μmol/g muscle</u>			SED	Significance of comparison (P values)		
	<u>In vivo</u>	<u>Perfused with</u>					
	(a)	SPM + 0.2mM serine (b)	SPM + 0.2mM serine + BCKAs (c)		avb	avc	bvc
Thr	0.756	0.404	0.58	0.109	n.s	n.s	n.s
Ser	1.37	1.405	1.24	0.166	n.s	n.s	n.s
Glu	0.815	0.452	0.857	0.129	<0.05	n.s	<0.05
Gln	4.60	2.48	2.06	0.54	<0.01	<0.01	n.s
Gly	5.69	5.49	5.07	0.42	n.s	n.s	n.s
Ala	2.60	2.55	2.54	0.64	n.s	n.s	n.s
Val	0.164	0.155	0.40	0.037	n.s	<0.01	<0.01
Ile	0.052	0.087	0.43	0.033	n.s	<0.001	<0.001
Leu	0.113	0.213	0.63	0.091	<0.05	<0.01	<0.01
Tyr	0.068	0.068	0.063	0.0176	n.s	n.s	n.s
Phe	0.084	0.069	0.07	0.02	n.s	n.s	n.s
Lys	0.766	0.60	0.81	0.21	n.s	n.s	n.s
His	0.28	0.26	0.31	0.042	n.s	n.s	n.s
Arg	0.376	0.213	0.44	0.10	n.s	n.s	n.s

n.s, not significant

BCKAs used were α-ketoisovaleric acid, α-keto-β-methylvaleric acid and α-ketoisocaproic acid (3 mM each)

Table 31. Efflux of amino acids from the sheep diaphragm

Amino acids	Amino acid efflux ($\mu\text{mol}/3\text{h}/30\text{g}$) (MEANS \pm SEM, n=5)
Asp	1.50 \pm 0.45
Thr	3.25 \pm 0.27
Glu	12.61 \pm 1.77
Ala	24.64 \pm 1.70
Gly	16.54 \pm 1.91
Val	4.31 \pm 0.62
Ile	2.16 \pm 0.26
leu	4.42 \pm 0.54
Tyr	2.14 \pm 0.27
Phe	2.12 \pm 0.28

glycine from the sheep diaphragm was lower than that from the rat hind-limb (28.41 $\mu\text{mol}/3\text{ h}/30\text{ g}$ muscle). As mentioned in section 3.2. for rat hind-limb the origin of glycine from the sheep diaphragm could be the proteolysis of muscle protein, degradation of bovine serum albumin by the muscle, 'leaching out' of intracellular glycine, degradation of muscle glutathione or *de novo* synthesis. These possibilities were also examined for the sheep diaphragm.

3.11.b. Intracellular amino acid concentrations in the sheep diaphragm

Decrease in the intracellular amino acid pool of glycine during the perfusion could also contribute to glycine efflux in the perfusion medium (also see section 3.3.b.). No significant change in the intracellular concentration of glycine was observed in the fresh and the 3 h perfused muscle (Table 32). Thus it is unlikely that leakage of glycine was the main cause of the glycine production by the muscle preparation. However, a small but significant decrease in the concentration of serine (a possible precursor of glycine) was observed when perfusions were carried out with the standard perfusion medium (Table 32). Similar results were obtained in the present study with the rat hind-limb (section 3.3.b.) and also by Kadowaki et al. (1984). Table 32 also gives the intracellular concentration of serine, glycine and tyrosine when the perfusion medium contained serine and 5-formyl tetrahydrofolate; this will be discussed in detail in the

Table 32. Intracellular concentrations of serine, glycine and tyrosine in the sheep diaphragm *in vivo* and perfused under different conditions (Mean values with pooled standard error of the difference by analysis of variance)

	<u>μmol/g muscle</u>				SED
	<i>In vivo</i> (n=6) (a)	SPM (n=7) (b)	SPM + 0.2mM serine (n=6) (c)	SPM + 0.2mM serine +2.5mM 5-CHO- THF (n=3) (d)	
Ser	0.51	0.41	0.61	0.59	0.06
Gly	1.40	1.41	1.22	1.47	0.22
Tyr	0.062	0.064	0.061	0.079	0.007

The difference between the groups was not significant except for ser (a v b, P < 0.05; b v c, P < 0.01; a v c, a v d, c v d not significant)

5-CHO-THF, 5-formyl tetrahydrofolate

(Muscle intracellular amino acid concentration was determined as described in section 2.13.)

Table 33. Amino acid concentration of the sheep plasma

Amino acid	Concentration ($\mu\text{mol}/100\text{ml}$)
Asp	2.90
Thr	12.40
ser	7.50
glu	16.20
gln	41.92
Pro	13.30
Gly	54.20
Ala	26.20
Val	19.80
Cys	1.10
Met	2.00
Ile	10.70
Leu	13.10
Tyr	8.30
Phe	5.10
Lys	5.80
His	1.30
Arg	1.15

The values are from Tao et al. (1974)

following sections. For calculation of the intracellular amino acid concentrations in the perfused muscle, the extracellular space of the perfused muscle was taken as $0.30 \pm 0.075(3)$ ml/g muscle (see section 3.1.b.iv.) and the free amino acid composition of the perfusate at 3 h was used. The intracellular amino acid composition of fresh muscle was calculated by taking the extracellular space of 0.26 ml/g muscle (Beckerton, 1976) and using the plasma amino acid composition given in Table 33.

3.11.c. Glutathione concentration of the sheep diaphragm

One of the sources of the glycine efflux observed during perfusion could be degradation of muscle glutathione (also see section 3.3.c.). Table 34 shows the reduced and oxidised glutathione content of fresh and 3 h perfused muscle. There was no significant change in the concentrations of both reduced and oxidised glutathione (fresh muscle : GSH $541 \pm 31.8(3)$ nmol/g muscle, GSSG $91.1 \pm 28.4(3)$ nmol/g muscle; perfused muscle : GSH $552 \pm 43(3)$ nmol/g muscle, GSSG $79.87 \pm 9.7(3)$ nmol/g muscle). Therefore, the glycine efflux was not likely to be due to degradation of muscle glutathione. The reduced glutathione concentration of the sheep diaphragm was less than that of the rat hind-limb muscle (Table 19 & 34). The value of GSH in rat hind-limb muscle agrees well with values already reported (Sedlak and Lindsay, 1968; Griffith and Meister, 1979). However, no such information is available in the literature for the sheep diaphragm.

Table 34. Glutathione concentration (nmol/g wet wt.) in the sheep diaphragm before and after perfusion

	<i>In vivo</i>	Perfused	Significance of difference
Reduced	541.2 ± 31.8(3)	552.0 ± 43(3)	ns
Oxidised	91.1 ± 28.4(3)	79.9 ± 9.7(3)	ns

ns, not significant

3.11.d. Hydrolysis of intracellular protein and bovine serum albumin ?

Another source of glycine released into the perfusion medium is proteolysis. Mixed muscle protein was shown to have glycine to tyrosine ratio of 2.92 : 1 (fresh muscle: $511.5 \pm 15.2(3) : 175 \pm 6.5(3) \mu\text{mol/g}$ trichloacetic acid precipitate, Table 35). Albumin is also known to be hydrolysed by muscle (Yedgar et al., 1983); however the amino acid composition of bovine serum albumin showed that glycine to tyrosine ratio is almost 1:1 ($234 \pm 12.3(3) : 266 \pm 7.8 \mu\text{mol/g}$, Table 15). The total tyrosine released into the medium when perfusions were done with the standard perfusion medium was $2.14 \pm 0.27 \mu\text{mol/3 h/30 g}$ muscle (Table 31). Assuming all this originated from mixed muscle protein and not the albumin and that no tyrosine was synthesised or degraded in muscle (Goldberg and Odessey, 1972; Teanne and Goldberg, 1976) then the maximum amount of glycine that is likely to be released due to proteolysis was $6.25 (2.14 \times 2.92) \mu\text{mol/3 h/30 g}$ muscle. If albumin was being degraded the amount of glycine released due to proteolysis would be even less.

3.11.e. De novo synthesis of glycine

It appears from the above that 'leaching out' of glycine from the intracellular glycine pool, degradation of muscle glutathione and proteolysis together do not account fully for the glycine efflux observed from the perfused

Table 35. Amino acid composition of the sheep diaphragm

(Means \pm SEM, n=6)

	$\mu\text{mol}/100\text{mg}$ trichloro- acetic acid precipitable protein	Amino acid to tyrosine ratio
Asp	61.68 \pm 1.4	3.52
Thr	32.62 \pm 0.99	1.86
Ser	32.08 \pm 0.81	1.83
Glu*	56.86	3.25
Gln*	32.08	1.83
Gly	51.15 \pm 1.52	2.92
Ala	58.32 \pm 2.92	3.33
Val	38.95 \pm 1.19	2.23
Cys	3.60 \pm 0.44	0.21
Met	12.46 \pm 1.02	0.71
Ile	25.82 \pm 0.48	1.48
Leu	53.26 \pm 0.79	3.04
Tyr	17.50 \pm 0.65	1.00
Phe	22.68 \pm 0.78	1.30
Lys	46.58 \pm 1.38	2.66
His	12.33 \pm 0.51	0.70
Arg	34.65 \pm 1.99	1.98

Amino acid composition of hindquarter muscle was determined as described in section 2.12.d.

* Glu + Gln was 88.94 \pm 1.77 $\mu\text{mol}/100\text{mg}$ trichloroacetic acid precipitable protein. Gln to glu ratio in a theoretical protein containing actin and myosin in the proportion they exist in skeletal muscle is 1:1.77 (Ruderman and Lund, 1972).

sheep diaphragm. The maximum amount of glycine that is likely to come from proteolysis of intracellular proteins and BSA was $6.25 \mu\text{mol}/3 \text{ h}/30 \text{ g}$ muscle. Thus, the minimum amount of *de novo* glycine synthesis by the sheep diaphragm is $10.29 \mu\text{mol}/3 \text{ h}/30 \text{ g}$ muscle (i.e. total glycine efflux, $16.54 \mu\text{mol}/3 \text{ h}/30 \text{ g}$ muscle (Table 31) minus glycine released due to proteolysis, $6.25 \mu\text{mol}/3 \text{ h}/30 \text{ g}$ muscle).

These studies suggest that the sheep diaphragm synthesises $10.29 \mu\text{mol}$ glycine/ $3 \text{ h}/30 \text{ g}$ muscle. The synthesis of glycine in the sheep diaphragm appears to be slightly lower than that in the rat hind-limb ($12.27 \mu\text{mol}/3 \text{ h}/30 \text{ g}$ muscle, see section 3.3.d.). The rate of proteolysis in the rat hind-limb was about 2-fold higher than that in the sheep diaphragm (efflux of tyrosine: rat hind-limb, $4.9 \mu\text{mol}/3 \text{ h}/30 \text{ g}$ muscle (Table 20); sheep diaphragm, $2.14 \mu\text{mol}/3 \text{ h}/30 \text{ g}$ muscle (Table 31)). The rate of metabolism of sheep muscle would of course be expected to be less than that of the rat, the sheep being a much larger animal.

3.11.f. Amino acid to tyrosine ratio in the muscle protein

Table 36 shows the amino acid to tyrosine ratio in trichloroacetic acid precipitable proteins of fresh and the perfused muscle. In the present study (sections 3.3.d. & 3.11.e.) and in previous studies (Ebisawa *et al.*, 1983; Coward and Buttery, 1982; Ruderman and Berger, 1974; Ward, 1976; Vernon, 1977; Shepperson, 1983) the amino acid to tyrosine ratio of fresh muscle was used to calculate the

Table 36. Amino acid to tyrosine ratio in the fresh and the perfused sheep diaphragm protein (trichloroacetic acid precipitable)

Amino acids	Ratio	
	Fresh muscle (6)	Perfused muscle (4)
Asp	3.54 ± 0.06	3.44 ± 0.09
Thr	1.87 ± 0.03	1.80 ± 0.04
Ser	1.84 ± 0.05	1.89 ± 0.05
Glu+gln	5.10 ± 0.09	5.09 ± 0.08
Gly	2.92 ± 0.14	3.10 ± 0.21
Ala	3.33 ± 0.29	3.60 ± 0.28
Val	2.24 ± 0.08	2.20 ± 0.08
Cys	0.21 ± 0.02	0.27 ± 0.07
Met	0.72 ± 0.06	0.72 ± 0.06
Ile	1.48 ± 0.05	1.44 ± 0.07
Leu	3.06 ± 0.07	3.03 ± 0.09
Phe	1.30 ± 0.02	1.29 ± 0.05
Lys	2.67 ± 0.04	2.70 ± 0.08
His	0.71 ± 0.02	0.75 ± 0.02
Arg	2.0 ± 0.16	1.89 ± 0.07

The results were not significantly different ($P > 0.05$) between the groups.

Values in parentheses show the number of muscle samples.

Amino acid composition of the sheep diaphragm was determined as described in section 2.12.d.

contribution of proteolysis towards the amino acid efflux. However, this would not provide a correct contribution if there is a 'specific' proteolysis in muscle, say of a glycine-rich protein. In the present study amino acid compositions of the fresh muscle proteins and that of the perfused muscle were measured. There was no significant change in the ratio of amino acids to tyrosine in trichloroacetic acid precipitable proteins obtained from the fresh and the perfused muscle (Table 36) suggesting that there was a 'non-specific' hydrolysis of proteins during perfusion and the release of amino acids as a result of proteolysis can be expected to be in the proportions in which they exist in fresh muscle protein. These results were not surprising.

3.12. SYNTHESIS OF GLYCINE FROM SERINE

The release of glycine from ruminant muscle is also accompanied by the removal of serine (Heitmann and Bergman, 1980), suggesting that glycine could be synthesised in muscle from serine. Glycine synthesis from serine was studied. The results are presented below.

3.12.a. Perfusion using the standard perfusion medium (SPM)

The glycine efflux was $16.54 \pm 1.91 \mu\text{mol}/3 \text{ h}/30 \text{ g}$ muscle when perfusions were done using SPM (for composition of the medium see section 2.6.b.). It accounted for about 15% of the total amino acids measured. As mentioned above a

Table 37. Effect of addition of serine and 5-formyl tetrahydrofolate (5-CHO-THF) to the standard perfusion medium (SPM) on the efflux of amino acids from the perfused sheep diaphragm (Mean values with pooled standard error of the difference by analysis of variance)

	<u>μmol/3h/30g muscle</u>			SED
	<u>Muscle perfused with</u>			
	SPM n=5	SPM + 0.2mM serine n=5	SPM + 0.2mM serine +2.5mM 5-CHO-THF n=3	
Asp	1.50	2.2	3.22	0.59
Thr	3.25	3.55	3.16	0.50
Glu	12.61	15.56	15.58	2.67
Gly	16.54	19.35	17.46	2.84
Ala	24.64	27.26	25.58	3.95
Val	4.31	3.89	4.77	1.10
Ile	2.16	1.99	2.13	0.45
Leu	4.42	4.03	4.15	0.76
Tyr	2.14	2.01	1.97	0.36
Phe	2.12	1.84	2.09	0.37

The difference between the groups for all the amino acids was insignificant

maximum of 6.25 μmol glycine/3 h/30 g muscle was released as a result of muscle protein degradation. Taking this into account the minimum amount of *de novo* glycine synthesis was 10.29 μmol /3 h/30 g muscle. The rate of glycine efflux was 6.54 ± 0.94 μmol /h/30 g muscle. The rate of glycine efflux observed for the rat hind-limb (8.74 ± 0.26 μmol /h/30 g muscle) (section 3.4.a.) was higher than that for the perfused sheep diaphragm (rates of glycine production were determined from first order portion of the graph). Under these conditions of perfusion, in the sheep diaphragm, no changes in the intracellular concentrations of glycine or tyrosine were found. However, there was a significant decrease in intracellular serine concentration (Table 32).

3.12.b. Effect of addition of serine to the standard perfusion medium (SPM)

Addition of 0.2 mM serine to the SPM did not stimulate the rate of glycine efflux significantly, although the mean rate of glycine efflux with 0.2 mM serine was higher than that observed without serine (Fig. 19) (with 0.2 mM serine, 7.8 ± 0.47 μmol /h/30 g muscle; without serine, 6.54 ± 0.94 μmol /h/30 g muscle; $P > 0.05$). Similarly, there was increase in the total efflux of glycine over the 3 h perfusion period on using 0.2 mM serine but the increase was not significant (with 0.2 mM serine: 19.35 ± 1.46 μmol /3 h/30 g muscle; without serine: 16.54 ± 1.91 μmol /3 h/30 g muscle; $P > 0.05$). Also the addition of 0.2 mM serine did not have any effect on the efflux of any other amino acid

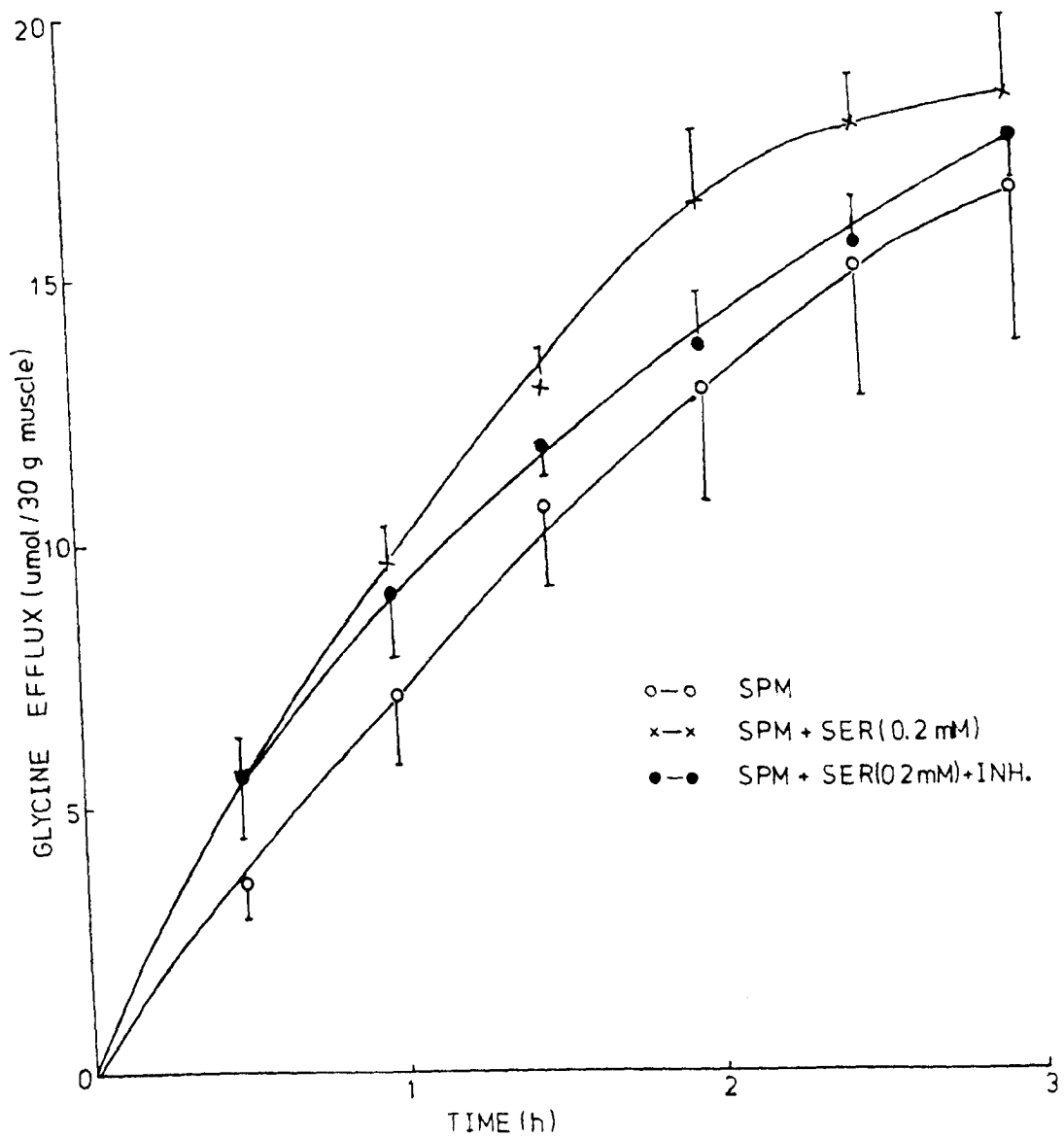

Fig. 19 Time course of glycine efflux from the perfused sheep diaphragm

(Rates of glycine production were assessed from the first order portion of the graph (1-2h). In most cases the efflux between 0 and 50 min was atypical, presumably reflecting the adjustment of the muscle to the perfusion system)

studied (Table 37). There were no differences in the intracellular concentrations of glycine, serine or tyrosine between fresh muscle and the muscle perfused with SPM containing 0.2 mM serine (Table 32). The minimum glycine synthesis under this condition was 13.48 $\mu\text{mol}/3\text{ h}/30\text{ g}$ muscle (i.e. total glycine released, 19.35 $\mu\text{mol}/3\text{ h}/30\text{ g}$ muscle, (Table 37) minus glycine released due to proteolysis, $2.01 \times 2.92 = 5.87$ $\mu\text{mol}/3\text{h}/30\text{ g}$ muscle (Table 35 & 37)). The glycine synthesis when the SPM contained 0.2 mM serine was 1.3 times higher than that observed when serine was not present. The results suggest that there is a conversion of serine to glycine in the perfused sheep diaphragm but the conversion does not appear to be very efficient. The serine to glycine conversion appears to be much smaller than that in the perfused rat hind-limb, as in the latter addition of 0.2 mM serine significantly stimulated the rate of glycine efflux and there was a significant increase in the total efflux of glycine. Also the addition of 0.2 mM serine increased the glycine synthesis by 1.7-fold (section 3.4.b.).

3.12.c. Effect of 5-formyl tetrahydrofolate addition to the standard perfusion medium containing 0.2 mM serine

The rate of glycine efflux on adding 5-formyl tetrahydrofolate, a specific inhibitor of serine hydroxymethyltransferase at a concentration of 2.5 mM, to the SPM containing 0.2 mM serine was 5.86 ± 0.6 $\mu\text{mol}/\text{h}/30\text{ g}$ muscle (Fig. 19). It was significantly ($P < 0.05$) lower than the rate

of glycine efflux observed with 0.2 mM serine alone ($7.8 \pm 0.47 \mu\text{mol/h/30 g muscle}$), and corresponded to a decrease of about 25%. However, there was no significant change in the total efflux of glycine at 3 h of perfusion (with inhibitor: $17.46 \pm 0.92 \mu\text{mol/3 h/30 g muscle}$, without inhibitor: $19.35 \pm 1.46 \mu\text{mol/3 h/30 g muscle}$; $P > 0.05$). The minimum glycine synthesis in the presence of the inhibitor was $11.71 \mu\text{mol/3 h/30 g muscle}$ (i.e. total glycine released, $17.46 \mu\text{mol/3 h/30 g muscle}$ (Table 37) minus glycine released due to proteolysis $1.97 \times 2.92 = 5.75$ (Table 35 & 37)), a decrease of about 13% (glycine synthesis in absence of the inhibitor : $13.48 \mu\text{mol/3 h/30 g muscle}$). The treatment caused no change in the efflux of any other amino acid studied (Table 37). No changes in intracellular concentrations of serine, glycine or tyrosine were found between the fresh and the perfused muscle (Table 32). The results indicate that serine hydroxymethyltransferase is taking part in the conversion of serine to glycine in the perfused sheep diaphragm.

3.13. INCORPORATION OF ^{14}C INTO AMINO ACIDS FROM (U- ^{14}C)GLUCOSE

The perfusions of the sheep diaphragm were carried out as described in section 3.5. The label was recovered in alanine and glutamate + glutamine peaks (Table 38). Unlike the perfused rat hind-limb the specific activity of glutamate + glutamine was higher than that of alanine

Table 38. Incorporation of ^{14}C into amino acids from
 (U- ^{14}C)glucose (0.2 $\mu\text{Ci/ml}$, 5.5 mM)* in the
 perfused sheep diaphragm

<u>Amino acids</u>	<u>Specific activity**</u> <u>(10^3 dpm/$\mu\text{mol-C}$)</u>
Alanine	0.56 (0.48, 0.64)
Glutamate + glutamine	0.83 (0.90, 0.76)

* Specific activity of (U- ^{14}C)glucose, 13.3×10^3 dpm/ $\mu\text{mol-C}$

** Average of two perfusions, individual values given in parentheses

(Table 22 & 38). The radioactivity could not be detected in serine or glycine peaks. There was some indication of aspartate being labelled. As explained earlier (section 3.5.) it was not possible to measure it. The synthesis of alanine, glutamate, glutamine and aspartate from glucose has been reported in rat diaphragm (Manchester and Young, 1959; Odessey et al., 1974). Based on the specific activity of glucose added and that of alanine in the medium at 3 h, 4.2% of total alanine-C released was found to have originated from exogenous glucose. This value is in accordance with the result (5.2%) of Coward and Buttery (1982).

3.14. INCORPORATION OF ^{14}C INTO AMINO ACIDS FROM (U- ^{14}C)SERINE AND (3- ^{14}C)SERINE

The sheep diaphragms were perfused with (U- ^{14}C)serine or (3- ^{14}C)serine at a concentration of 0.1 $\mu\text{Ci/ml}$, serine 0.2 mM.

3.14.a. Specific activities of the labelled amino acids

Glycine, methionine, aspartate, glutamate + glutamine, alanine and cystine were labelled when the perfusion medium contained (U- ^{14}C)serine. On using (3- ^{14}C)serine the radioactivity was recovered in methionine, aspartate, glutamate + glutamine, alanine and cystine; however, no radioactivity was incorporated into glycine (Table 39). The specific activities of methionine, alanine, aspartate,

Table 39. Production of radiolabelled amino acids from (U-¹⁴C)serine and (3-¹⁴C)serine (both used at 0.1 μ Ci/ml, 0.2 mM) in the perfused sheep diaphragm

Amino acids	Specific activity (10^3 dpm/ μ mol)	
	(U- ¹⁴ C)serine	(3- ¹⁴ C)serine
Glycine	19.19 \pm 5.17	n.d.
Methionine	21.24 \pm 3.14	37.26 \pm 9.84
Alanine	1.87 \pm 0.46	1.75 \pm 0.25
Aspartate	8.09 \pm 0.67	9.93 \pm 0.4
Glutamate + glutamine	0.89 \pm 0.05	0.95 \pm 0.16
Cystine	7.78 \pm 0.38	11.86 \pm 1.72

Values are Means \pm SEM(n=3)

The difference between the groups for all the amino acids was not significant

n.d., not detected (limit of detection 0.2×10^3 dpm/ μ mol)

cystine and glutamate + glutamine obtained with (U- ^{14}C)serine do not differ significantly from those obtained with (3- ^{14}C)serine. The specific activity of methionine obtained using (3- ^{14}C)serine was about 2 times higher than that obtained with (U- ^{14}C)serine (Table 39). The incorporation of label from 3-C of serine to methyl group of methionine suggests that ruminant muscle is also active in synthesising active 'one-carbon' units.

3.14.b. Time course of glycine and serine radioactivity

The radioactivity of (U- ^{14}C)serine in the perfusate dropped rapidly (by 33% of the initial) in the first 60 min of perfusion. In the next 120 min of perfusion the decrease in the radioactivity was only about 22%. A similar pattern was observed for the decrease of (3- ^{14}C)serine radioactivity. However, the rate of incorporation of label from (U- ^{14}C)serine into glycine went on increasing as the time progressed. After 3 h of perfusion about 46% of initial serine radioactivity was recovered in (U- ^{14}C)serine (Fig. 20, Table 40). In the perfused rat hind-limb the radioactivity recovered in serine was much lower (12%) (section 3.6.b.) suggesting that in rat hind-limb serine is metabolised to a greater extent than in sheep diaphragm. After 3 h of perfusion in the sheep diaphragm, about 1.5% of the initial serine radioactivity was recovered in glycine in the medium. This value was about 4.6 times lower than that obtained in the perfused rat hind-limb. This observation also suggests that serine to glycine conversion

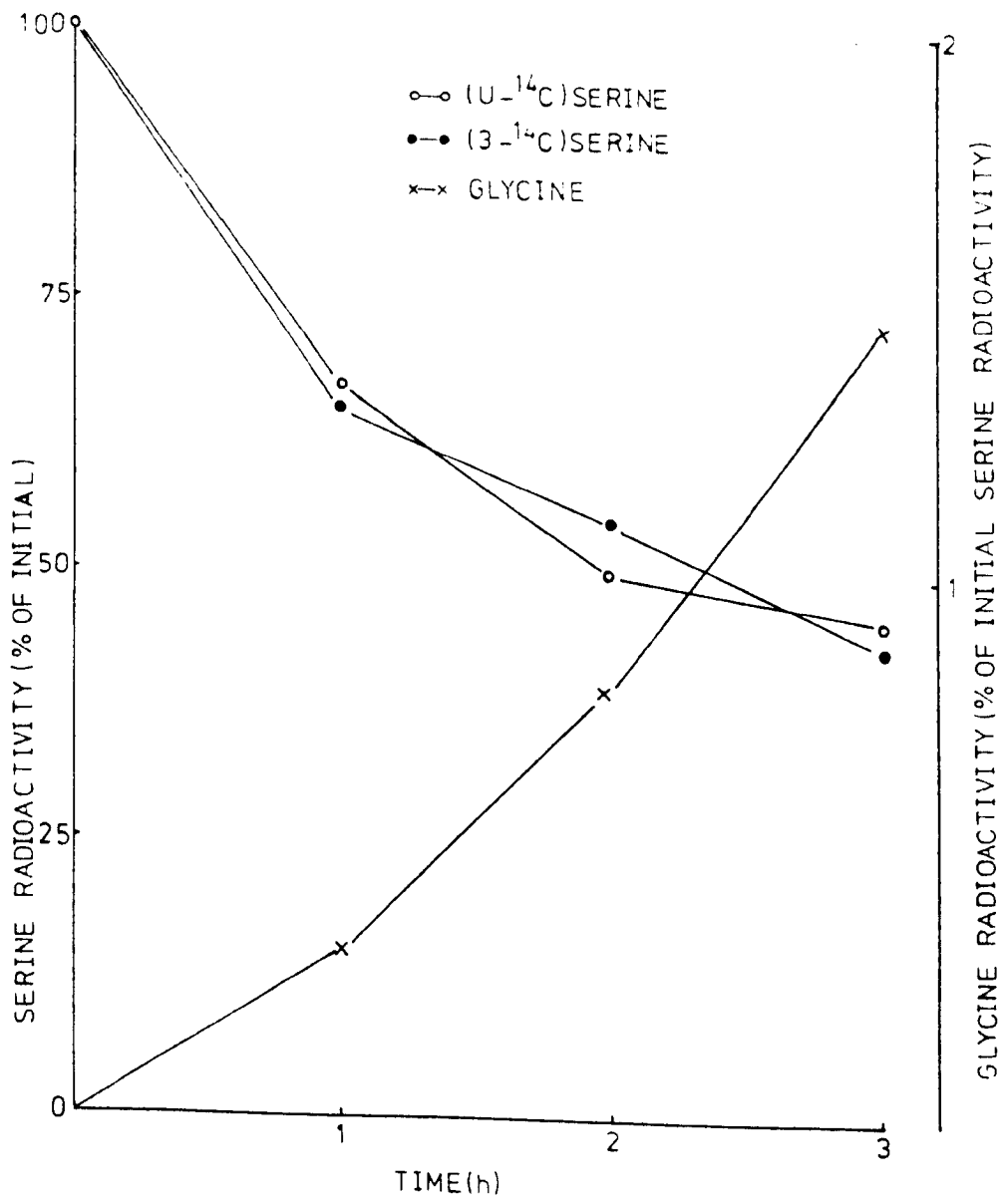

Fig. 20 Time course of glycine and serine radioactivity in the medium

Table 40. Glycine and serine radioactivity (% of initial serine radioactivity) in the perfusate during perfusion of the sheep diaphragm

	Radioactivity (% of initial radioactivity)		
	1h	2h	3h
Glycine*	0.30 (0.26,0.34)	0.79 (0.85,0.73)	1.46 (1.35,1.56)
(U- ¹⁴ C)serine*	67.21 (65.03,69.40)	50.16 (52.60,47.72)	45.55 (42.30,48.8)
(3- ¹⁴ C)serine	65.37 ± 7.90(3)	54.77 ± 8.50(3)	43.40 ± 8.40(3)

*, average from 2 perfusions, individual values shown in parentheses

in sheep diaphragm is less than that in rat hind-limb (also see section 3.12.b.).

3.14.c. Specific activities of glycine and serine in the medium

The specific activities of labelled glycine obtained from (U- 14 C)serine and that of (U- 14 C)serine and (3- 14 C)serine at different times of perfusion are given in Table 41, Fig. 21. The specific activity of glycine increased with time. It suggested that the rate of incorporation of label from (U- 14 C)serine to glycine increased as the perfusion progressed. However, it was not the case with perfused rat hind-limb (section 3.6.d.). The reason for this difference is not clear. There was a drop of about 40% in the specific activities of both the labelled serine in 3 h (Fig. 21). This suggests that besides conversion of serine to glycine there could also be a synthesis of serine in perfused sheep diaphragm and/or the serine could be coming from proteolysis of muscle protein and albumin. A similar decrease in the specific activities of (U- 14 C)serine and (3- 14 C)serine with time was observed in perfused rat hind-limb (see section 3.6.d.). The rate of release of serine into the medium from the perfused rat hind-limb appears to be higher than that from the perfused sheep diaphragm, as a greater drop in specific activities of (U- 14 C)serine and (3- 14 C)serine (about 80%) following 3 h of perfusion was observed for rat hind-limb (section 3.6.d.).

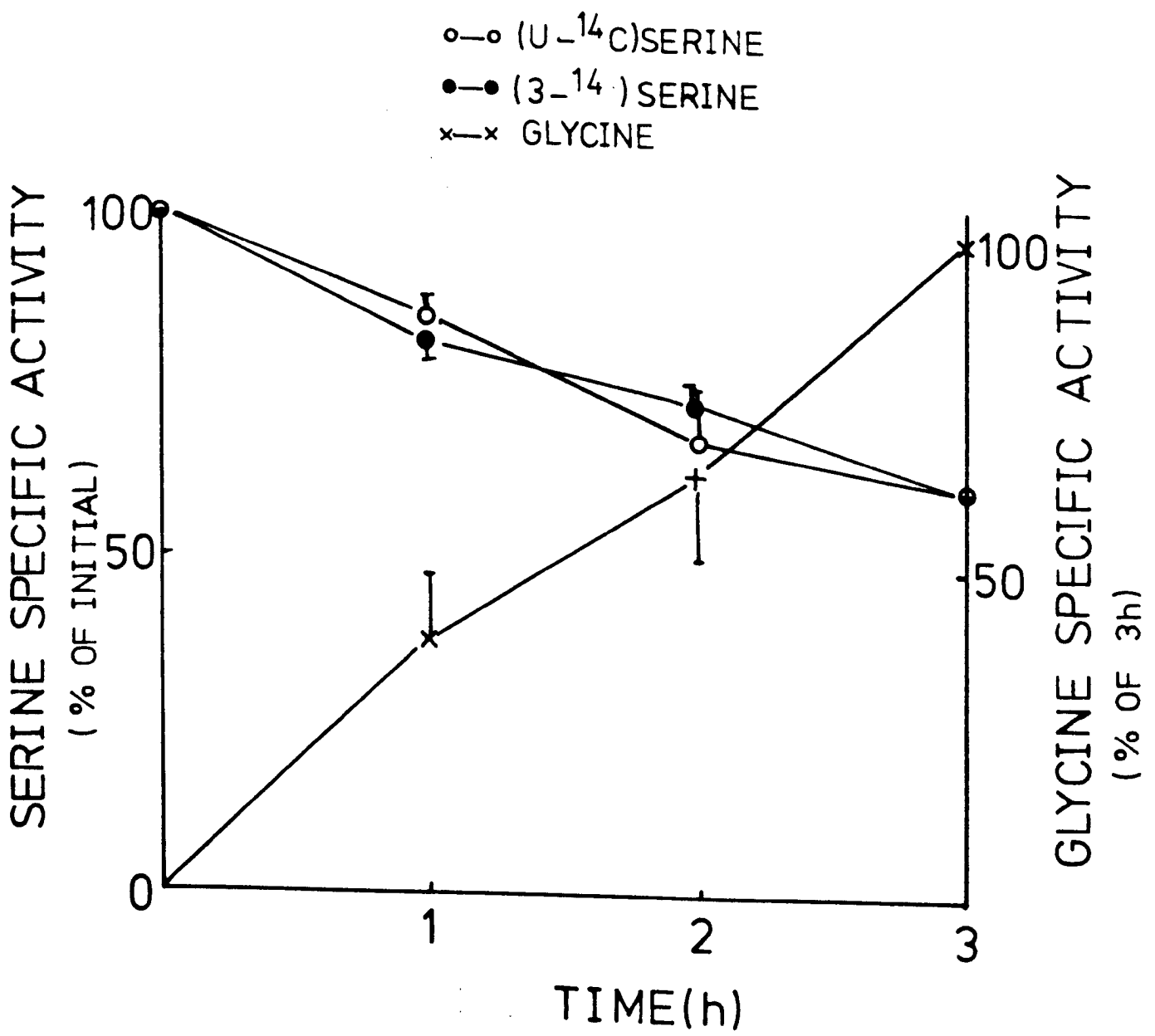

Fig. 21 Specific activities of glycine and serine in the medium

Table 41. Specific activities of labelled glycine,
 (U-¹⁴C)serine and (3-¹⁴C)serine in the perfusion
 medium during perfusion of the sheep diaphragm

		<u>Specific activity (10³dpm/μmol)</u>			
		0*	1h	2h	3h
Glycine	0		7.35 \pm 1.9(3)	12.19 \pm 2.1(3)	19.19 \pm 5.17(3)
(U- ¹⁴ C)serine	1100		933.99 \pm 32.33(3)	733.71 \pm 107.64(3)	659.16 \pm 14.01(3)
(3- ¹⁴ C)serine	1100		901.86 \pm 34.39(3)	792.15 \pm 47.46(3)	661.32 \pm 31.62(3)

* 10 min after the addition of radiochemical (see section 2.7.)

3.14.d. Amount of glycine derived from serine in the perfused sheep diaphragm

Per cent glycine derived from serine was calculated as described earlier in section 3.6.e.

Per cent glycine derived from serine:

- i) using the data of 1 h = 1.2%
- ii) using the data of 2 h = 2.5%
- iii) using the data of 3 h = 4.4%

The efflux of glycine from sheep diaphragm was also atypical between 0 and 50 min of perfusion (section 3.12.a. & Fig. 19). So the value obtained using the data of 1 h may be a poor representative of the expected *in vivo* value. Thus in sheep diaphragm upto 4.4% of glycine appears to be derived from serine. Again as mentioned in section 3.6.e. for the rat hind-limb, this value would be an overestimate if the synthesis of glycine from serine is taking place by coupled action of serine hydroxymethyltransferase and glycine synthase. However, the results of this study suggest that glycine is synthesised by serine hydroxymethyltransferase and not by glycine synthase (reverse of glycine cleavage system) in sheep diaphragm.

3.14.e. Distribution of glycine and serine radioactivity

The distribution of glycine and serine radioactivity in the perfusion medium (PM), muscle free amino acid pool (MFAAP) and muscle-bound amino acids (MBAA) after 3 h of perfusion using (U-¹⁴C)serine is shown in Table 42. A total of 3.25% of the initial serine radioactivity was found in

Table 42. Distribution of glycine and serine radioactivity following perfusion of the sheep diaphragm using (U-¹⁴C)serine (0.1 μ Ci/ml, 0.2 mM)

	<u>% of initial serine radioactivity</u>			Total
	Perfusion medium	Muscle free amino acid pool	Muscle-bound amino acid	
Glycine	1.25 \pm 0.40 (3)	1.59 \pm 0.24 (3)	0.41 \pm 0.22 (3)	3.25 \pm 0.60 (3)
Serine	40.26 \pm 1.86 (3)	23.90 \pm 3.60 (3)	1.63 \pm 0.77 (3)	65.73 \pm 4.32 (3)

(Samples were prepared for determination of radioactivity in perfusate, muscle free amino acids and muscle-bound amino acids as described in section 2.14.c.)

glycine. The distribution of this was : PM, 1.25% (38% of total glycine recovered); MFAAP, 1.59% (49% of total glycine recovered) and MBAA, 0.41% (13% of total glycine recovered). In the perfused rat hind-limb, a much higher level of labelling (about 22% of initial serine radioactivity) was observed in glycine (section 3.6.c.). This also suggests that the serine to glycine conversion in sheep diaphragm is much lower than that in rat hind-limb (also see sections 3.12.b. & 3.14.b.).

In perfused sheep diaphragm, a total of about 66% of the initial serine radioactivity remained as such after 3 h of perfusion. It was distributed between the PM, MFAAP and MBAA in the proportions 61.1%, 36.4%, and 2.5% respectively (Table 42). In the rat hind-limb, about 35% of the initial serine radioactivity was left as such in the system (see section 3.6.c.), which suggests that serine is metabolised to a greater extent in the rat hind-limb as compared with the sheep diaphragm.

3.15. EFFECT OF BRANCHED-CHAIN KETO ACIDS (BCKAs) ON GLYCINE SYNTHASE IN THE PERFUSED SHEEP DIAPHRAGM

In the absence of BCKAs in the perfusion medium the glycine was not labelled from (3-¹⁴C)serine (section 3.14.a.). The label from 3-C of serine is transferred to glycine by glycine synthase (see section 1.5.a.). The BCKAs (α -keto isovaleric acid, α -keto- β -methylvaleric acid and α -ketoisocaproic acid) increased the activity of glycine synthase in rat liver (O'Brien, 1978). With this in view,

the sheep diaphragms were also perfused with the standard perfusion medium containing both (3-¹⁴C)serine (0.1 μ Ci/ml, 0.2 mM serine) and BCKAs (3 mM each). As observed for the rat hind-limb (section 3.7.) glycine was not labelled from (3-¹⁴C)serine even in the presence of BCKAs. However, the label was recovered in methionine peak (Table 43) again giving confidence that glycine synthase is not active in sheep diaphragm. Unlike in the perfused rat hind-limb (Table 26) the specific activity of methionine when BCKAs were present in the perfusion medium decreased significantly in sheep diaphragm (Table 43). The reason for this difference is not known.

3.16. LABELING OF C-1 AND C-2 OF GLYCINE

The radioactivity in C-1 and C-2 of glycine isolated from perfusate (see section 2.16.) following perfusion with (U-¹⁴C)serine was determined as mentioned in sections 2.16. & 2.17. respectively. The radioactivity in C-1 and C-2 of glycine was equally distributed (Table 44). Similar results were obtained for perfused rat hind-limb (section 3.8.).

3.17. SYNTHESIS OF GLYCINE FROM THREONINE

Some evidence is available which shows that the metabolism of threonine in ruminants differs from that in non-ruminants (see Morton, 1980). In rat, about 20-33% of dietary threonine is degraded to glycine. However, rat muscle does not appear to synthesis glycine from threonine

Table 43. Specific activity of methionine following perfusion of the sheep diaphragm in absence and presence of branched-chain keto acids (BCKAs)

	<u>Specific activity (10^3 dpm/μmol)</u>		Significance of comparison
	<u>Perfused with</u>		
	SPM+(3- 14 C) serine* (n=3)	SPM+(3- 14 C) serine* +BCKAs (n=3)	
Glycine	n.d	n.d	-
Methionine	37.26 \pm 9.8	6.27 \pm 1.54	P < 0.005

SPM, Standard perfusion medium; n.d, not detected (limit of detection 0.2×10^3 dpm/ μ mol)
 * used at 0.1 μ Ci/ml (0.2 mM)
 BCKAs used were α -ketoisovaleric acid, α -keto- β -methylvaleric acid and α -ketoisocaproic acid (3 mM each)

Table 44. Radioactivity in C-1 and C-2 of labelled glycine isolated following perfusion of the sheep diaphragm with (U-¹⁴C)serine

	Radioactivity in C-1 (% of total)	Radioactivity in C-2 (% of total)
Perfusion I	45.40 ± 3.90(3)	49.99 ± 1.48(3)
Perfusion II	45.00 ± 2.65(4)	48.47 ± 0.86(3)
Perfusion III	48.50 ± 0.49(3)	52.59 ± 1.45(3)
Mean	46.30 ± 1.10(3)	50.35 ± 1.20(3)

Radioactivity in C-1 of glycine was determined by the method of Rowsell et al. (1975) and in C-2 by the method developed by the author (see section 2.17.)

to any significant extent (see section 3.9.a.). Sheep diaphragm perfusions were carried out using (U- ^{14}C)threonine (0.1 $\mu\text{Ci/ml}$, 0.2 mM).

3.17.a. Incorporation of ^{14}C into glycine from (U- ^{14}C)threonine

Labelled glycine was recovered (specific activity: $2436 \pm 361(3)$ dpm/ μmol , Table 45). The label in glycine suggests the synthesis of glycine from threonine in perfused sheep diaphragm. The specific activity of glycine obtained from (U- ^{14}C)threonine for perfused sheep diaphragm was about 8 times higher than that obtained for perfused rat hind-limb (Table 27 & 45) inferring that threonine might be a better substrate for glycine synthesis in sheep diaphragm than in rat hind-limb. However, for both sheep diaphragm and rat hind-limb, serine is a better substrate than threonine for glycine synthesis. About 0.4% of total glycine released originated from threonine (for calculations see section 3.9.a.). Unlike rat hind-limb, there was no decrease in the specific activity of the precursor during the perfusion (initial, 2.75×10^5 dpm/ $\mu\text{mol-C}$; 3 h, 3×10^5 dpm/ $\mu\text{mol-C}$).

3.17.b. Distribution of glycine and threonine radioactivity

The distribution of glycine and threonine radioactivity in the perfusion medium (PM), muscle free amino acid pool (MFAAP) and muscle-bound amino acids (MBAA) following 3 h perfusion using (U- ^{14}C)threonine are given in Table 46. A total of only 0.17% of the initial threonine radioactivity was found in glycine. A majority (about 76%) of this was in

Table 45. Specific activity of glycine following perfusion of the sheep diaphragm using (U-¹⁴C)threonine and (U-¹⁴C)serine (both used at 0.1 μCi/ml, 0.2 mM)

	<u>Specific activity (10³ x dpm/μmol)</u>
(U- ¹⁴ C)Threonine	2.44 ± 0.36(3)
(U- ¹⁴ C)Serine	19.19 ± 5.17(3)*

*, taken from Table 39

Table 46. Distribution of glycine and threonine radioactivity following perfusion of the sheep diaphragm using (U-¹⁴C)threonine (0.1 μ Ci/ml, 0.2 mM)

	<u>% of initial serine radioactivity</u>			Total
	Perfusion medium	Muscle free amino acid pool	Muscle-bound amino acid	
Glycine	0.13 \pm 0.02(3)	0.04 \pm 0.01(3)	0	0.17
Threonine	63.5 \pm 7.4(3)	22.8 \pm 2.4(3)	1.58 \pm 0.06(3)	87.88

(Samples were prepared for determination of radioactivity in perfusate, muscle free amino acids and muscle-bound amino acids as described in section 2.14.c.)

PM and the rest in MFAAP. However in the perfused rat hind-limb, the total radioactivity recovered in glycine was lower (0.11% of the initial threonine radioactivity) and majority of this (64%) was in MFAAP and the rest in PM. In the sheep diaphragm a total of about 88% of the initial threonine radioactivity remained as such after 3 h of perfusion, which is higher than that obtained in the perfused rat hind-limb (71%) (section 3.9.b.). The results suggest that degradation of threonine in sheep diaphragm is lower than that in rat hind-limb, but higher amount of threonine degraded goes to the formation of glycine in sheep diaphragm. After 3 h of perfusion in the sheep diaphragm, about 66% of the initial serine radioactivity remained as such, which suggests that in sheep diaphragm (as in rat hind-limb) serine is metabolised to a greater extent than is threonine.

3.18. EFFECT OF BRANCHED-CHAIN KETO ACIDS (BCKAs)

The perfusions of sheep diaphragm were carried out using BCKAs in the standard perfusion medium. The objectives of this experiment were the same as mentioned in section 3.10. for the rat hind-limb.

3.18.a. Efflux of amino acids from the perfused sheep diaphragm

Table 47 shows the efflux of amino acids from the perfused sheep diaphragm. There was a significant decrease in the efflux of glutamine, alanine and methionine in the

Table 47. Effect of addition of branched-chain keto acids (BCKAs) in the standard perfusion medium (SPM) containing 0.2mM serine on the efflux of amino acids from the sheep diaphragm (Mean values with pooled standard error of the difference by analysis of variance)

	<u>μmol/3h/30g muscle</u>		Significance of comparison
	<u>Muscle perfused with</u> SPM+0.2mM serine (n=5)	<u>SPM+0.2mM serine + BCKAs</u> (n=3)	
Asp	2.20 ± 0.19	2.53 ± 0.46	n.s
Thr	3.55 ± 0.29	2.06 ± 1.46	n.s
Gln	25.29 ± 2.26	14.08 ± 3.56	P < 0.05
Glu	15.56 ± 1.38	13.73 ± 4.89	n.s
Gly	19.35 ± 1.46	13.96 ± 3.86	n.s
Ala	27.26 ± 1.88	20.69 ± 2.62	P < 0.1
Val	3.89 ± 0.63	4.25 ± 0.75	n.s
Met	0.74 ± 0.06	0.48 ± 0.07	P < 0.05
Ile	2.00 ± 0.18	3.01 ± 0.38	P < 0.05
Leu	4.03 ± 0.30	8.77 ± 0.73	P < 0.01
Tyr	2.01 ± 0.14	1.71 ± 0.31	n.s
Phe	1.84 ± 0.06	1.52 ± 0.14	n.s
Lys	-	2.96 ± 0.38	-
His	-	1.30 ± 0.14	-
Arg	-	1.83 ± 0.2	-

n.s not significant

BCKAs used were α-ketoisovaleric acid, α-keto-β-methylvaleric acid and α-ketoisocaproic acid (3 mM each)

presence of BCKAs in the perfusion medium. Glycine efflux decreased (28%) in presence of BCKAs in the medium but the decrease was not significant ($P > 0.1$). The change in glycine efflux was quite variable (in two of the three perfusions the decrease was 52% and 44%, and in the third no decrease was observed). The efflux of isoleucine and leucine increased significantly on perfusion with the medium containing BCKAs. There was an increase (but insignificant) in the efflux of valine. No change in the efflux of any other amino acid was observed (Table 47). These observations suggest that some of the available nitrogen was incorporated to BCKAs. Similar results have been obtained for rat hind-limb (see section 3.10.a.).

3.18.b. Intracellular amino acids concentrations in the sheep diaphragm

The intracellular amino acid concentrations of sheep diaphragm perfused with and without BCKAs are shown in Table 48. The intracellular concentration of isoleucine and leucine was significantly higher when the perfusions were carried out with the medium containing BCKAs. Also an increase in the intracellular concentration of valine was observed on perfusion with the medium containing BCKAs, but it was not significant. There was no significant change in the intracellular concentration of any of the other amino acids studied (Table 48). These observations also suggest that ruminant muscle is also capable of transaminating the keto analogues of these three essential amino acids to their corresponding amino acids.

Table 48. Intracellular amino acid concentrations of sheep diaphragm *in vivo* and after perfusion with the standard perfusion medium (SPM) containing 0.2 mM serine and with the SPM containing both 0.2 mM serine and branched-chain keto acids (BCKAs) (Mean values with pooled standard error of the difference by analysis of variance)

	<u>μmol/g muscle</u>			SED	Significance of comparison (P values)		
	<u>In vivo</u>	<u>Perfused with</u>					
		SPM + 0.2mM serine	SPM + 0.2mM serine + BCKAs				
	n=5 (a)	n=7 (b)	n=3 (c)		avb	avc	bvc
Asp	0.278	0.084	0.114	0.054	<0.001	<0.02	n.s
Thr	0.265	0.253	0.176	0.05	n.s	n.s	n.s
Ser	0.51	0.41	0.44	0.06	n.s	n.s	n.s
Glu	2.52	1.118	1.27	0.31	<0.001	<0.01	n.s
Gly	1.40	1.22	0.89	0.24	n.s	n.s	n.s
Ala	4.01	4.70	3.12	0.98	n.s	n.s	n.s
Val	0.227	0.147	0.223	0.064	n.s	n.s	n.s
Ile	0.047	0.054	0.20	0.024	n.s	<0.01	<0.001
Leu	0.146	0.137	0.50	0.023	n.s	<0.001	0.001
Tyr	0.062	0.064	0.10	0.02	n.s	n.s	n.s
Phe	0.053	0.074	0.081	0.016	n.s	n.s	n.s
Lys	0.184	0.194	0.195	0.03	n.s	n.s	n.s
His	0.167	0.167	0.129	0.039	n.s	n.s	n.s
Arg	0.25	0.23	0.19	0.03	n.s	n.s	n.s

n.s., not significant

BCKAs used were α-ketoisovaleric acid, α-keto-β-methylvaleric acid and α-ketoisocaproic acid (3 mM each)

D. SERINE HYDROXYMETHYLTRANSFERASE (EC 2.1.2.1) ACTIVITY

3.19. SERINE HYDROXYMETHYLTRANSFERASE (SHMT) ACTIVITY OF THE RAT AND SHEEP TISSUES

The rate of organ metabolism measured using perfused organ technique is close to that expected *in vivo* (see section 1.7.). In the present study, perfused rat hind-limb and sheep diaphragm preparations were used to study the synthesis of glycine in muscle. To extrapolate some of the results obtained to diaphragm and liver of the rat, and hind-limb muscle and liver of the sheep, SHMT (EC 2.1.2.1.) activity was measured in liver, diaphragm and hind-limb muscle of both rat and sheep. SHMT is an important enzyme in the synthesis of glycine in muscle.

3.19.a. Serine hydroxymethyltransferase activity in the rat tissues

Table 49 shows the activity of SHMT in diaphragm, hind-limb muscle (gastrocnemius) and liver of rat. The activity of the enzyme in liver agrees well with the values reported by Snell (1980a). The enzyme activity was in the order: liver > diaphragm > hind-limb muscle (liver, $2.47 \pm 0.07(8)$; diaphragm, $0.13 \pm 0.01(8)$ and hind-limb muscle, $0.056 \pm 0.003(8)$ units/g wet wt.). These values represent the maximum values and not the actual *in vivo* values as the reactions were carried out under optimum conditions (saturation with substrate and cofactor). Substrate and cofactor concentrations *in vivo* are not necessarily optimal. Many enzymes operate at concentration near the K_m Value (Cleland, 1967). The synthesis of glycine in the perfused

Table 49. Serine hydroxymethyltransferase activity of diaphragm, hind-limb muscle and liver of rat

	<u>Activity</u> Units/g wet wt
Diaphragm	0.13 ± 0.01 (8)
Hind-limb muscle (gastrocnemius)	0.056 ± 0.003 (8)
Liver	2.47 ± 0.07 (8)

1 unit = 1 μ mol HCHO formed/min at 37°C

rat hind-limb observed in the present study (on using 0.2 mM serine in the perfusion medium; near the plasma concentration of serine) was found to be about 14 times lower than the glycine synthesis calculated from the *in vitro* SHMT activities (glycine synthesis : perfused hind-limb, 21.39 $\mu\text{mol}/3 \text{ h}/30 \text{ g}$ muscle (section 3.4.b.); *in vitro*, 302 (0.056 x 60 x 3 x 30) $\mu\text{mol}/3 \text{ h}/30 \text{ g}$ muscle). Such discrepancies between assayed enzyme activity and actual *in vivo* activity have been observed for many enzymes (Krebs and Lund, 1977).

3.19.b. Serine hydroxymethyltransferase activity in the sheep tissues

The enzyme activity of diaphragm, hind-limb muscle (vastus lateralis) and liver of sheep is given in Table 50. The pattern of enzyme activity was similar to that observed in rats i.e. activity in liver > diaphragm > the hind-limb muscle. The enzyme activity of both sheep diaphragm and sheep hind-limb muscle was lower than the corresponding values for rat (sheep diaphragm, $0.04 \pm 0.003(9)$ units/g; rat diaphragm, $0.13 \pm 0.01(8)$ units/g; sheep hind-limb muscle, $0.021 \pm 0.002(9)$ units/g; rat hind-limb muscle, $0.056 \pm 0.003(8)$ units/g). However, for liver the enzyme activity was higher in sheep than rat (sheep liver, $10.88 \pm 0.68(6)$ units/g; rat liver, $2.47 \pm 0.07(8)$ units/g). The glycine synthesis in the perfused sheep diaphragm observed in the present study (13.48 $\mu\text{mol}/3 \text{ h}/30 \text{ g}$ muscle; 0.2 mM serine in the perfusion medium, see section 3.12.b.) was about 16 times lower than the glycine synthesis calculated from SHMT activity of sheep diaphragm.

Table 50. Serine hydroxymethyltransferase activity of diaphragm, hind-limb muscle and liver of sheep

	<u>Activity</u> <u>(Units/g wet wt.)</u>
Diaphragm	0.04 ± 0.003(9)
Hind-limb muscle (vastus lateralis)	0.021 ± 0.002(9)
Liver	10.88 ± 0.68(6)

1 unit = 1 μ mol HCHO formed/min at 37°C

E. GLYCINE SYNTHESIS IN ANABOLIC CONDITIONS

3.20. GLYCINE SYNTHESIS IN THE TRENBOLONE ACETATE AND TESTOSTERONE TREATED RAT

During studies carried out in this laboratory on the mode of action of anabolic compounds, a consistent increase in the plasma and intracellular concentration of glycine was observed in animals treated with trenbolone acetate (TBA), an androgenic agent (see Buttery, 1978). Also the efflux of glycine from hind-limbs of TBA treated rats was higher than that from the untreated controls (Vernon, 1977). Informal discussions with other groups have suggested that they have also noted this increase. We wondered what this increase is due to. So the attempts were made to study the effects of TBA and testosterone on the activity of serine hydroxymethyltransferase (SHMT) in liver, diaphragm and gastrocnemius muscle of female rats. These two agents were chosen because of a marked difference in their actions on protein synthesis and catabolism. In rat muscle, glycine was synthesised mainly from serine by SHMT (see section 3.6.e.).

3.20.a. The trenbolone acetate treated rat

i) Effect of trenbolone acetate on growth rate of the rat

TBA was injected to rats as mentioned in section 2.2.c. The changes in body weight and growth rate are recorded in Table 51 & Fig. 22. The mean body weight of rats in the

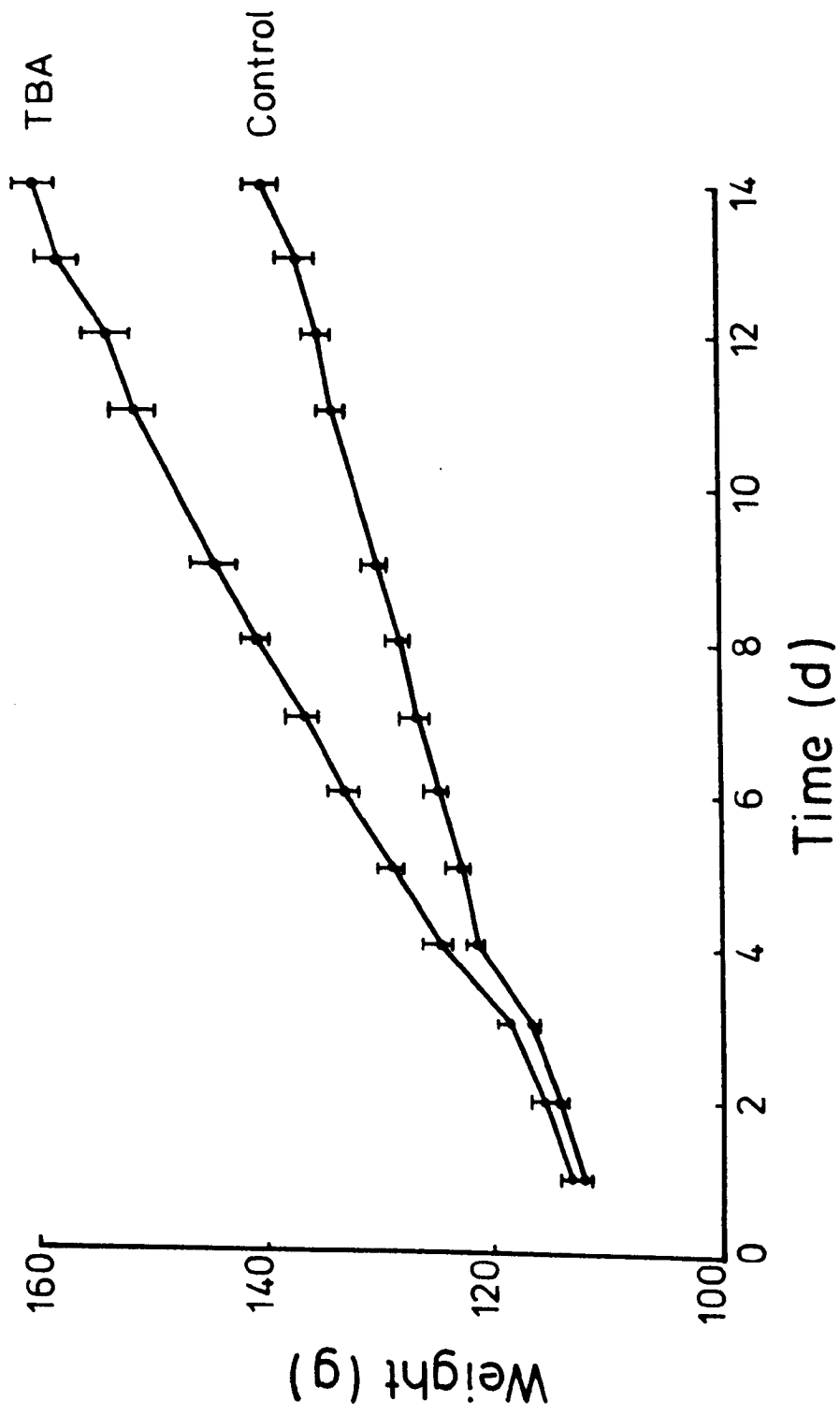

Fig. 22 Effect of trenbolone acetate on weight gain in female rats

Table 51. The effect of trenbolone acetate (TBA) on growth rate of female rat

	Oil placebo	TBA	Significance of comparison
Initial BW(g)	112.6 \pm 0.67	113.1 \pm 0.62	n.s
Final BW(g)	139.8 \pm 1.08	160.2 \pm 1.65	P < 0.001
Growth rate (g/day)	1.72 \pm 0.09	3.60 \pm 0.1	P < 0.001

BW, body weight; n.s, not significant
 The values are Means \pm SEM (n=18)

control (oil placebo) and TBA group before start of the injection was not significantly different. After 14 days of injection the mean body weight of TBA treated rats was significantly higher than that of the placebo control (control: $139.77 \pm 1.08(18)$ g, TBA: $160.24 \pm 1.65(18)$ g; $P < 0.001$). The growth rate of the TBA treated group was $3.60 \pm 0.1(18)$ g/day as compared to that of the control ($1.72 \pm 0.09(18)$ g/day). The increase in the growth rate illustrated that the rats responded to the agent.

ii) Effect of trenbolone acetate on serine hydroxymethyl-transferase activity

Table 52 shows the activity of SHMT in liver, diaphragm and hind-limb muscle (gastrocnemius) of the control and the TBA treated rats. The activity increased significantly in all the three tissues studied. The increases in activity were about 7%, 25%, and 34% in liver, diaphragm, and hind-limb muscle respectively.

iii) Effect of trenbolone acetate on water content of the tissues

The water content of liver, diaphragm, and hind-limb muscle (gastrocnemius) did not change significantly on TBA treatment (Fig. 23). These observations suggested that the increase in SHMT activity was not due to changes in water content of the tissues.

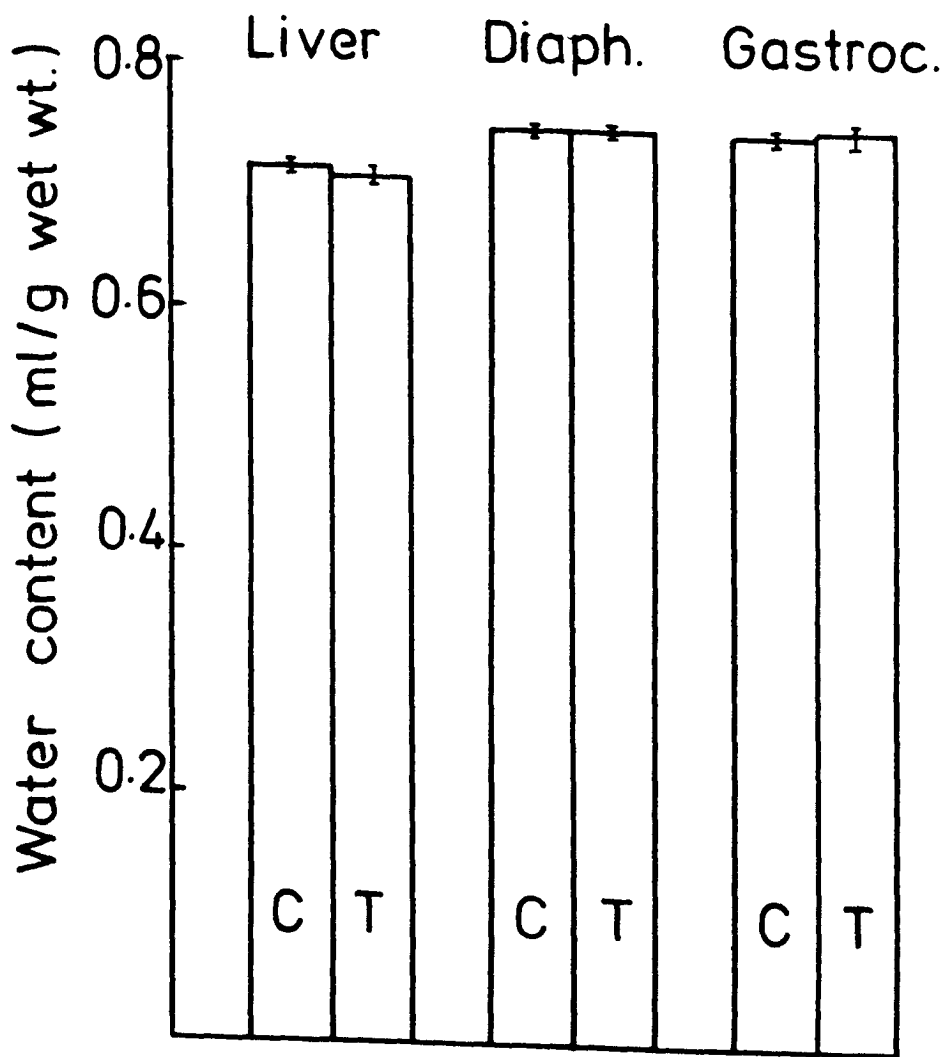

Fig. 23 Effect of trenbolone acetate on water content of tissues

3.20.b. The testosterone treated rat

i) Effect of testosterone on growth rate of the rat

The testosterone was injected to the rats as mentioned in section 2.2.c. The changes in body weight and growth rate are shown in Table 53 & Fig. 24. Before start of the injection, the mean body weight of rats in the control (oil placebo) and TBA group was not significantly different. After 14 days of the injection body weight of the testosterone treated rats was significantly higher than that of the placebo control (control: $145.2 \pm 1.08(8)$ g, testosterone: $161.8 \pm 2.82(8)$ g; $P < 0.001$). The growth rate of the testosterone treated group was about 1.7 times higher than that of the placebo control group. The stimulation in the growth rate showed that the rats were responding to the testosterone treatment.

ii) Effect of testosterone on serine hydroxymethyl-transferase activity

The enzyme activity in liver, diaphragm, and the hind-limb muscle (gastrocnemius) of testosterone treated rats was significantly higher than that of the control rats (Table 54). The increases in the enzyme activity were about 10%, 19%, and 26% respectively in liver, diaphragm, and gastrocnemius muscle.

iii) Effect of testosterone on water content of the tissues

There was no significant change in the water content of both liver and the hind-limb muscle (gastrocnemius) (Fig. 25). The water content of diaphragm could not be

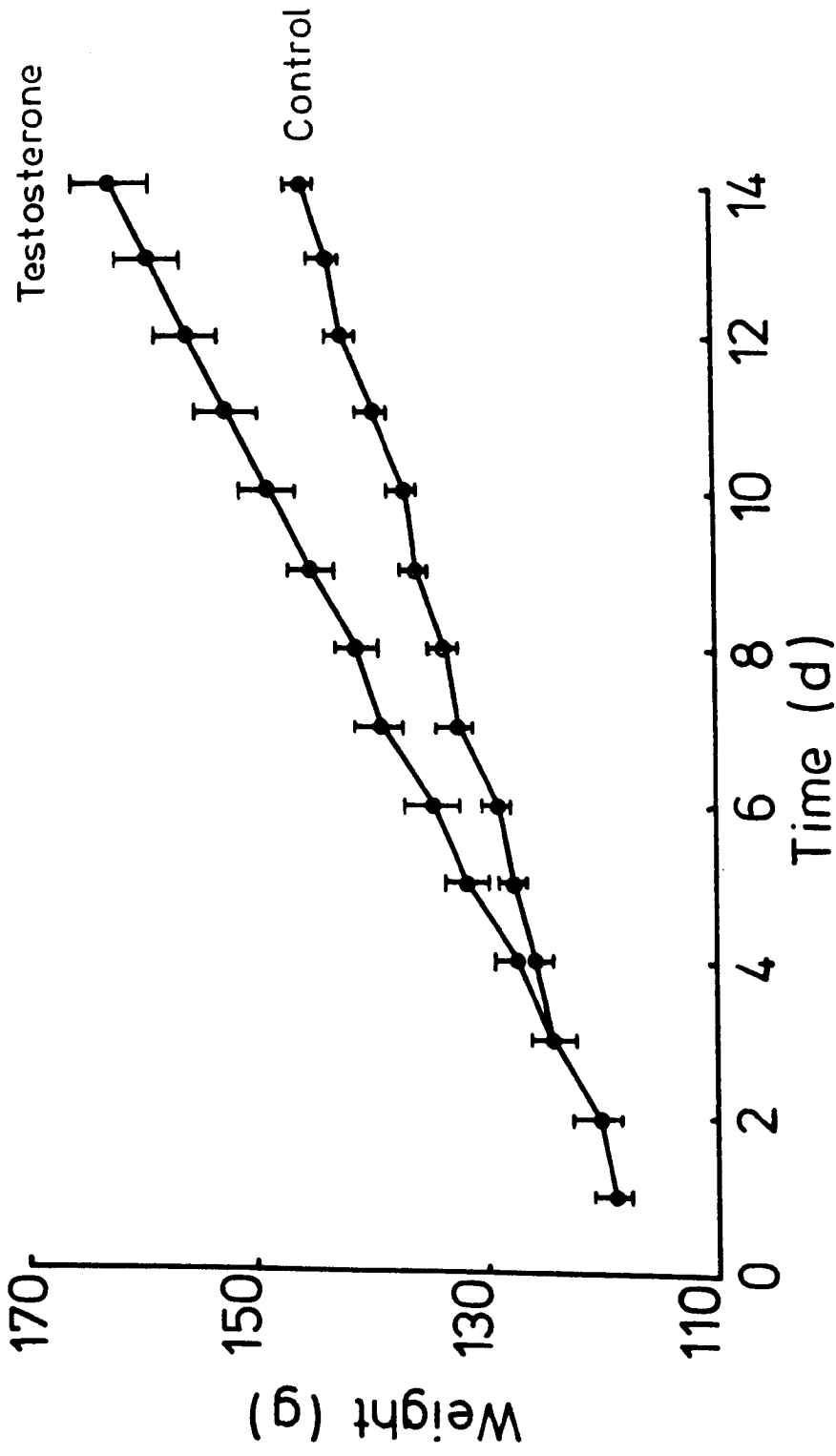

Fig. 24 Effect of testosterone on weight gain in female rats

Table 52. The effect of trenbolone acetate on the activity of serine hydroxymethyltransferase

	<u>Enzyme activity (units/g wet wt)</u>		Significance of comparison
	Control	Trenbolone acetate	
Liver (n=7)	2.23 ± 0.04	2.39 ± 0.05	P < 0.05
Diaphragm (n=8)	0.079 ± 0.005	0.10 ± 0.007	P < 0.05
Gastrocnemius muscle (n=12)	0.057 ± 0.003	0.076 ± 0.003	P < 0.001

The values are Means ± SEM
 1 unit ≡ 1 μmol HCHO formed/min at 37°

Table 53. The effect of testosterone on growth rate of female rat

	Oil placebo	Testosterone	Significance of comparison
Initial BW(g)	118.4 \pm 1.10	118.6 \pm 1.49	n.s
Final BW(g)	145.2 \pm 1.08	161.8 \pm 2.82	P < 0.001
Growth rate (g/day)	2.02 \pm 0.07	3.41 \pm 0.13	P < 0.001

BW, body weight; n.s, not significant
 The values are Means \pm SEM (n=8)

Table 54. The effect of testosterone on the activity of serine hydroxymethyltransferase

	<u>Enzyme activity (units/g wet wt)</u>		Significance of comparison
	Control	Testosterone	
Liver	2.71 \pm 0.02 (n=8)	2.98 \pm 0.04 (n=8)	P < 0.001
Diaphragm	0.082 \pm 0.004 (n=7)	0.098 \pm 0.004 (n=8)	P < 0.01
Gastrocnemius muscle	0.050 \pm 0.001 (n=7)	0.063 \pm 0.004 (n=8)	P < 0.001

The values are Means \pm SEM
 1 unit \equiv 1 μ mol HCHO formed/min at 37°

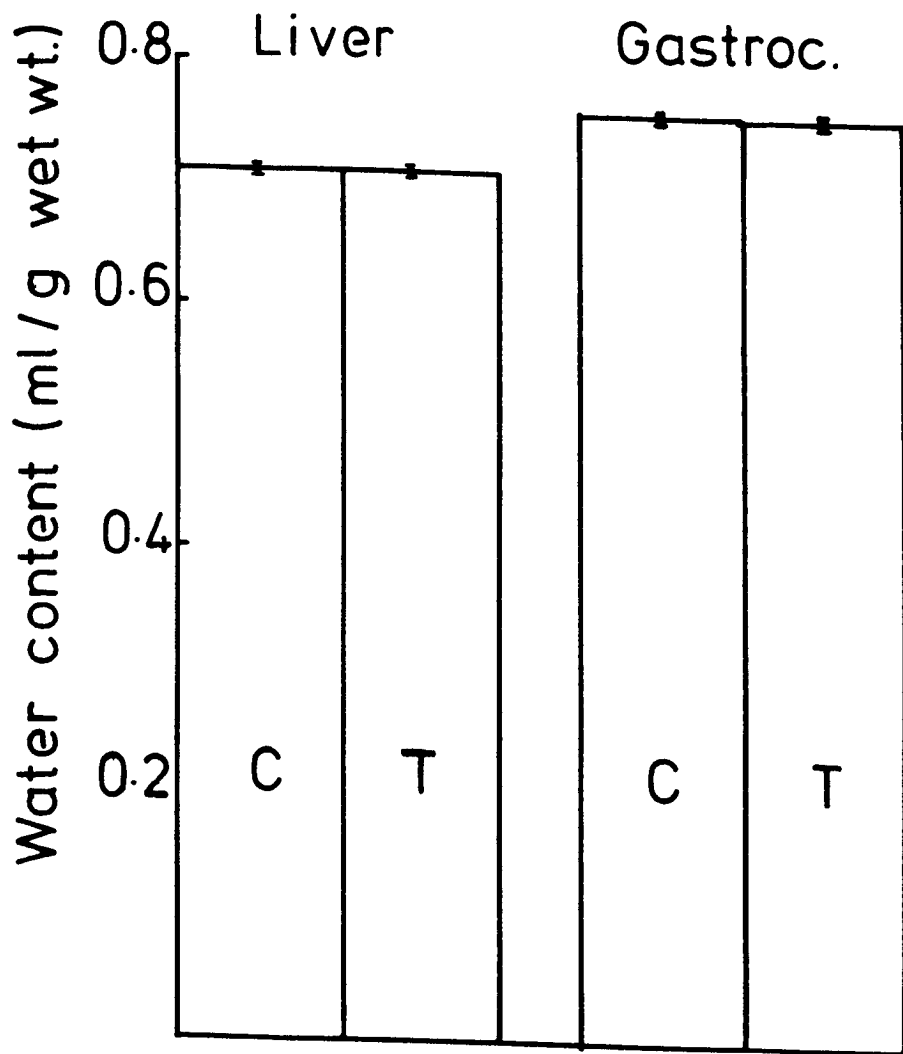

Fig. 25 Effect of testosterone on water content of tissues

determined as the weight of diaphragm obtained ranged from 150-200 mg, all of which was used for the determination of enzyme activity. In TBA trial, determination of water content of diaphragm was possible due to the large number of rats used. The lack of significant change in water content of the tissues showed that the increase in the enzyme activity on the testosterone treatment could not be attributed to this.

DISCUSSION

4.1. COMMENTS ON EXPERIMENTAL TECHNIQUES USED

4.1.a. Isolated perfused muscle preparations

The importance of perfusion techniques in studying biochemical mechanisms in muscle has long been recognised (Skutul, 1908). However, most workers found consistent and reproducible preparations difficult to produce. As a result, in earlier studies research advances were most successful using other *in vitro* methods such as the tissue slices and homogenates. In recent years simplification of the perfusion system and the careful selection of perfusion conditions have resulted in organ preparations that are reproducible. The isolated perfused muscle affords several advantages over other *in vitro* muscle preparations (see section 1.7.).

Despite a number of advantages, the isolated perfused organ can not be considered as truly physiological. There is a loss of nervous control and especially in a recirculating perfusion system there is a build-up of metabolic end products. Moreover, costs of perfusion apparatus, perfusion medium and monitoring devices are often limitations to perfusion experiments.

The procedure adopted in this study for the perfusion of isolated rat hind-limb was based on that described by Ruderman et al. (1971). On the basis of experiments carried out in this laboratory (Ward, 1976), some modifications were made to the method of Ruderman et al., which are mentioned below:

- a) The rat was hemisected to prevent blood seepage into the systemic circulation.
- b) The concentration of bovine serum albumin in the medium was increased from 4% to 8% (w/v) to reduce the extent of oedema.
- c) Freshly obtained washed rat erythrocytes were used in preference to human red cells.
- d) The haematocrit was reduced to 10 ml cell volume/100 ml perfusate.

A flow rate of 9-11 ml/min (depending on the weight of muscle perfused) was maintained. This flow rate was selected on the basis of the observations of Ruderman *et al.* (1980). These workers showed that a flow rate of approx. 0.33 ml/min/g muscle oxygenates the hind-limb adequately.

Perfusions using radiochemicals were carried out by the method of Strohfeldt *et al.* (1974) and Reimer *et al.* (1975). This method was essentially the same as that of Ruderman *et al.* (1971) or Ward and Buttery (1979) except that the perfusion medium was free of erythrocytes and the medium was passed through the organ at a higher flow rate. In the present work radiochemicals were used mainly to study the mechanisms of different reactions in the muscle. Therefore, a perfusion medium free of erythrocytes was preferred in order to eliminate any possible effects of erythrocytes (problem with erythrocytes is presumably the glutathione in the red blood cells, for other advantages of erythrocyte-free medium see section 1.8.). The procedure used in the

present study differed in the following respects from that of Strohfeltdt et al. (1974).

1. Glucose in the medium was 5.5 mM instead of 10 mM and there was no lactate or oleate in the medium. The pyruvate in the medium was 0.15 mM.
2. At a pressure of 8-9 cm of Hg (the pressure used in the present study for the preparations perfused with erythrocyte-containing medium) a flow rate of 16-19 ml/min was observed, whereas a flow rate of 40-45 ml/min was obtained at 7.5-8.5 cm of Hg by Strohfeltdt et al. (1974). No efforts were made to increase the flow rate by increasing the pressure as the organ was found to be in a viable state even at this flow rate (see the following section).

For the preparation of the isolated sheep diaphragm, the method used in the present work was based on that of Coward and Buttery (1980). Given the disadvantages of erythrocyte-containing medium (section 1.8.) efforts were made to perfuse the sheep diaphragm with erythrocyte-free medium and study the viability of the diaphragm. Similar work carried out on liver and rat hind-limb (Bloxam, 1971; Strohfeltdt et al., 1974; Reimer et al., 1975; Sugano et al., 1978) showed that the organ studied remained in a reasonably good condition. In the present work it was found that, when the diaphragms were perfused with an erythrocyte-free medium at a flow rate of 11-13 ml/min, they remained in a viable state (see section 4.1.b.ii.).

4.1.b. Tests of perfusion viability

Perfusion has been defined as the maintenance of the organ in a viable state, isolated from the animal, by means of mechanically assisted circulation of an artificial medium through its vascular bed (Ross, 1972). Before using the perfused organ for any studies, it is imperative to ensure that the organ remains in a viable state during the experimental period. The conditions necessary for adequate perfusion and the appropriate tests for perfusion viability becomes apparent when the causes and consequences of inadequate perfusions are considered (Fig. 26). These events have been particularly well defined for the perfused liver but are of general application to other organs. This sequence of events suggests that appropriate tests of perfusion viability should include the monitoring of metabolites for example tissue ATP, ADP and AMP concentrations and lactate and potassium efflux into the perfusate; these change markedly if the perfusion is inadequate. Examination of the isolated perfused tissue with naked eye and its composition also give useful information about viability of perfused organs.

i) The hind-limb preparation

An exhaustive study for determining the viability of rat hind-limb perfused with erythrocyte-containing medium was not carried out, as the method used in the present work was well established in our laboratory and was in routine use. The viability of preparation was judged by visual

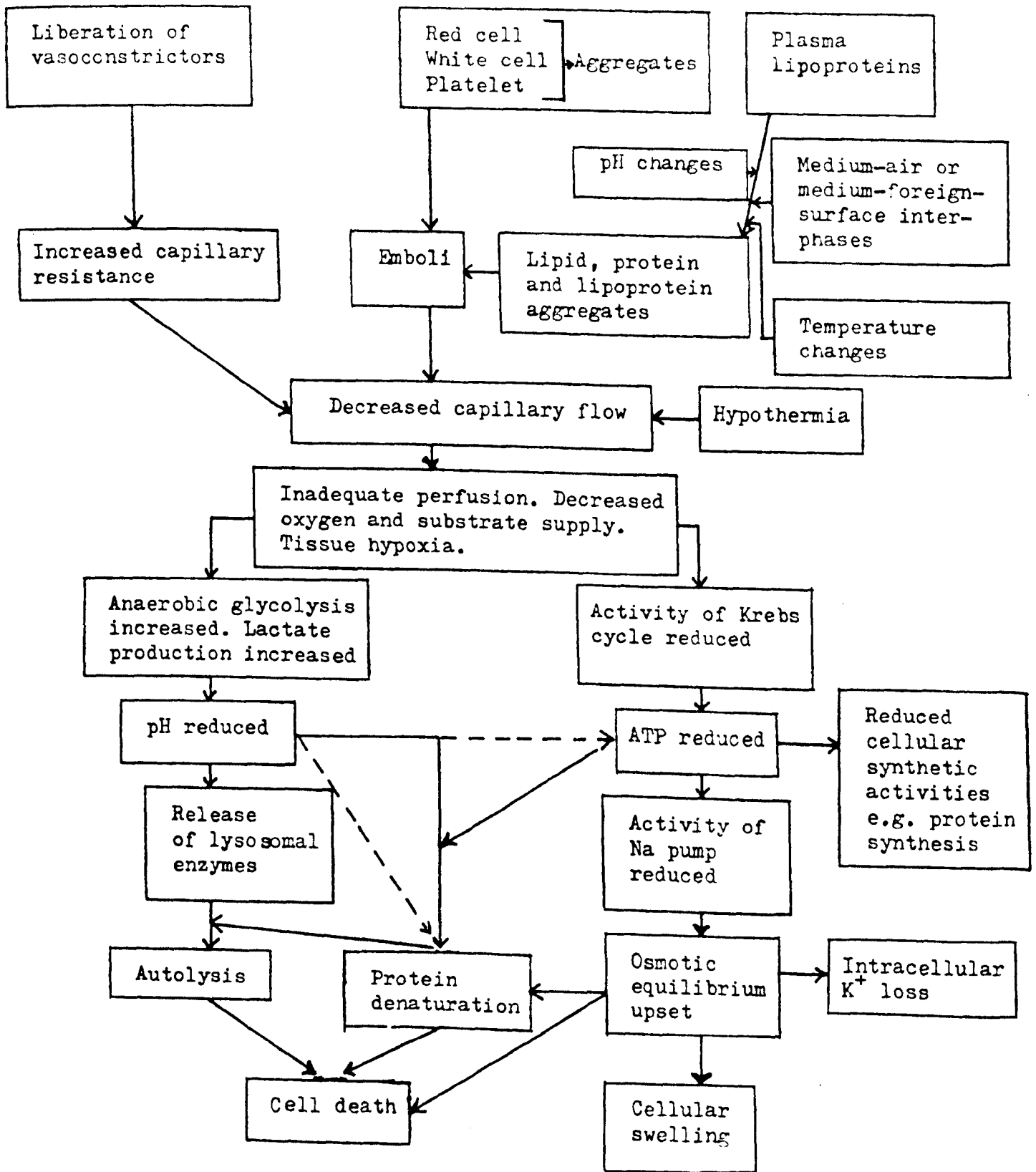

Fig. 26 The physiological causes and consequences of inadequate perfusion of an organ (Adapted from Lawrie, 1968; Belzer *et al.*, 1968; Cohen & Folkman, 1968)

examination, flow rate, pH measurements, muscle water content and potassium efflux.

During perfusion there were no signs of oedema or cyanosis. Oedema and cyanosis are observed when there is inadequate perfusion (Ruderman et al., 1971). Also the fact that a constant flow rate (9-11 ml/min) was observed at a particular pressure (8-9 cm of Hg) throughout the perfusion period suggests that the preparation remained in good condition during the period of perfusion.

The water content of the perfused muscle was almost identical to that observed *in vivo* (Table 10). Potassium efflux is one of the most sensitive indicators of decreased tissue integrity (Ruderman and Herrera, 1968). Efflux of cellular potassium from muscle deprived of oxygen has been reported by Rixon and Stephenson (1956) and potassium efflux is associated with the uptake of water by the cell (D'silva and Neil, 1954). In the present study, the efflux of potassium was $227 \pm 13.6(4) \mu\text{mol}/3 \text{ h}/30 \text{ g}$, which forms 5.5% of total muscle potassium. This loss of potassium was similar to that obtained by Ruderman et al. (1971) and Ward (1976).

However, when the perfusions were carried out using erythrocyte-free medium, the muscle ATP, ADP, lactate and pyruvate were also estimated in additions to the tests described above.

Perfused muscle ATP and ADP concentrations were not significantly different from those observed *in vivo* (Table 10). The values of ATP and ADP in perfused muscle and in

vivo found in this study were of similar magnitude to those observed previously (Ruderman *et al.*, 1971; Jefferson *et al.*, 1972; Reimer *et al.*, 1975; Jefferson *et al.*, 1977). Ruderman *et al.* (1971) have suggested that a low ATP concentration in the perfused muscle is another indication of an unsatisfactory perfusion. This view has been supported by the studies of Bloxam (1971) using perfused rat liver. However, Reimer *et al.* (1975) have questioned the validity of this parameter as only small changes in the ATP and ADP content of gastrocnemius muscle were observed during anoxic periods of upto 1 h. On the basis of their studies using N_2/CO_2 in place of O_2/CO_2 to gas the perfusate, they suggested creatine phosphate was a better parameter for the evaluation of the metabolic state of the perfused hind-limb.

It must however be acknowledged that the methods used to estimate ATP and ADP in the present study, as with other most investigations, are not entirely specific (they also estimate ITP, GTP, UDP and CDP etc.) (Jaworek, 1974a,b). However, the effect of these compounds on the results obtained was assumed to be negligible as their concentration in muscle has been reported to be very low (Schmitz *et al.*, 1954; Lawrie, 1968; Jefferson *et al.*, 1971).

Similarly, no change in muscle lactate or pyruvate or lactate/pyruvate ratio following perfusion indicated that muscle was adequately oxygenated; in 'bad' or hypoxic perfusions an increase in the ratio of tissue lactate/pyruvate occurs (Goodman *et al.*, 1973; Bloxam, 1971). In addition, there were no obvious signs of oedema or cyanosis;

there was no difference in water content between the perfused muscle and the fresh muscle and there was no significant difference in potassium loss from the muscle when the perfusions were carried out with erythrocyte-containing or erythrocyte-free medium (Table 10).

Conclusion

On the basis of comparisons made between the results obtained in the present system and those of other workers using comparable perfusion methods, and also with metabolite concentrations *in vivo*, it is concluded that the perfusion system used in these studies maintained the rat hind-limb in a viable state. Hence, it is reasonable to assume that the present isolated perfused hind-limb preparation is satisfactory, is useful for the study of muscle metabolism and that the data obtained using this system will reflect the situation *in vivo*.

ii) The sheep diaphragm preparation

A number of criteria have been used for assessing perfused preparations. These include arterial perfusion pressure, oedema or water content, intracellular space, muscle creatine phosphate, ATP, ADP, AMP, lactate and pyruvate concentrations, muscle lactate to pyruvate ratio, lactate, pyruvate and K^+ , O_2 consumption, histological and electron - microscopic examination (Ruderman *et al.*, 1971; Jefferson *et al.*, 1972; Mehl *et al.*, 1964; Barak *et al.*,

1971; Rookledge, 1971; O' Donovan *et al.*, 1975; Dohm *et al.*, 1980; Caldwell *et al.*, 1978; Rennie and Holloszy, 1977; Ruderman *et al.*, 1980, Ward and Buttery, 1979; Miller *et al.*, 1954; Strohfeltd *et al.*, 1974, Preedy *et al.*, 1984; Coward and Buttery, 1980).

In the present study, most of the above mentioned criteria (except histological and electron - microscopic examination) were used to study the viability of the sheep diaphragm perfused with erythrocyte-free medium.

An adequate supply of O₂ is essential for keeping the organ in a viable state during perfusion. The data on O₂ consumption by the perfused sheep diaphragm suggested that the preparation was adequately oxygenated at a flow rate of about 11 ml/min (Table 12). With erythrocyte-containing medium a flow rate as low as 4 ml/min appeared to keep the preparation in a viable state (Shepperson, 1983). An O₂ consumption of $8.45 \pm 0.73(5)$ $\mu\text{mol/h/g}$ muscle was observed for the diaphragm in the present study (section 3.1.b.xi.). No comparable data is available for the studies carried out with erythrocyte-containing medium. For the perfused rat hind-limb an O₂ consumption of 13-40 $\mu\text{mol/h/g}$ muscle has been recorded by different workers (Ruderman *et al.*, 1980).

No decline in the ratios of ATP/ADP and (ATP)/(ADP+AMP) nor any significant increase in the muscle lactate/pyruvate ratio was observed following 3 h perfusion (Table 11). In a 'bad' or hypoxic perfusion, a decline in the ratios of tissue ATP/ADP and (ATP)/(ADP+AMP) and increase in the ratio

of tissue lactate/pyruvate occurs (Bloxam, 1971; Goodman *et al.*, 1973). However, phosphocreatine levels decreased significantly after 3 h of perfusion in the present study. Preedy *et al.* (1984) also observed a decline in phosphocreatine levels in their normal rat hind-limb perfusions although there was no change in ATP and ADP compared with *in vivo* concentrations. Similar results to that of Preedy *et al.* (1984) were also observed by Rannels *et al.* (1975) for perfused rat heart. Ruderman *et al.* (1971) had previously reported fall in phosphocreatine during perfusion of the rat hind-limb and had deemed them inadequate on this basis.

In anoxia, a decrease in glycogen has been reported (Cornblath *et al.*, 1963). No significant change in glycogen concentration was observed following perfusion in the present study. In contrast, Coward and Buttery (1980) observed a decrease in glycogen concentration following perfusion with erythrocyte-containing medium. The difference appears to be due to the different methods used for glycogen estimation. The method used in the present study (Roehrig and Allred, 1974) is more accurate and sensitive as compared to that (Good *et al.*, 1933) used by Coward and Buttery (1980). The latter method involves the precipitation and purification of glycogen and is subject to losses at these steps.

The loss of tissue potassium over 3 h perfusion observed in this study (4.7% of total tissue K⁺ content) was

2.5 and 4 times less respectively than those observed by Shepperson (1983) and by Coward and Buttery (1980) in their perfusions with erythrocyte-containing medium. Similar losses of K^+ , 5% over 2 h of perfusion (Ruderman et al., 1971) and 7% over 3 h of perfusion (Ward, 1976) were observed with rat hind-limb perfusions.

The extent of the increase in muscle water and extracellular space was similar to those observed when perfusions were carried out with a medium containing-erythrocytes (Coward and Buttery, 1980; Shepperson, 1983). On visual examination, a small degree of fibre separation and a small retention of medium between the fibre bundles of perfused muscle was observed. Fibre separation was also observed when perfusions were done with medium containing erythrocytes (Coward, 1978). As there was very little increase in muscle water or extracellular space, this did not seem to affect the functional integrity of the muscle.

The lactate efflux ($671 \pm 28.4(3) \mu\text{mol}/3 \text{ h}/30 \text{ g muscle}$) observed in the present study was less than that observed by Coward and Buttery (1980) ($1458 \pm 89.7 \mu\text{mol}/3 \text{ h}/30 \text{ g muscle}$) but was higher than that reported by Shepperson (1983) ($327 \pm 126(4) \mu\text{mol}/3 \text{ h}/30 \text{ g muscle}$). Ruderman et al. (1971) judged their rat hind-limb perfusions hypoxic if lactate production was greater than $240 \mu\text{mol}/\text{h}/30 \text{ g muscle}$. Some workers have reported even higher rates of lactate production than this for their 'adequate' perfusions (Strohfelddt et al., 1975a,b). So solely on the basis of

lactate efflux it is difficult to judge whether the perfusions are 'adequate' or 'bad'.

The ratio of amino acid efflux to tyrosine efflux from sheep diaphragm perfused with medium absent of erythrocytes (Table 13) was the same as that observed when the perfusions were carried out with erythrocyte-containing medium (Coward and Buttery, 1982). This also suggests that a diaphragm perfused with erythrocyte-free medium behaves substantially as the one perfused with erythrocyte-containing medium from the point of view of amino acid metabolism.

Conclusion

It was concluded that sheep diaphragms perfused with medium free of erythrocytes were in an equally good state as those perfused with erythrocyte-containing medium.

4.2. RATE OF GLYCINE SYNTHESIS FROM SERINE -- WHOLE BODY

STUDIES

Arnstein and Neuberger (1953) calculated the rates of glycine and serine synthesis in rats by feeding labelled glycine and serine for a long period. However, the calculations made from these experiments imply some assumptions which are unlikely to be completely correct (Neuberger, 1981). More recently, dynamic aspects of whole body metabolism have been studied using continuous intravenous infusion of radioactive isotopes (e.g. Chochinov *et al.*, 1978; Robert *et al.*, 1982). Fern and Garlick (1974) with entirely different objectives in mind have reported data from which it is possible to calculate an estimate of total body synthesis of glycine and the proportion of this resulting from serine.

1. Per cent of total glycine-C derived from serine-C

This can be calculated from the following formula:

$$\frac{[\text{glycine equilibrium specific activity in plasma} / 2]}{[\text{serine equilibrium specific activity in plasma} / 3]}$$

After infusion with (U-¹⁴C)serine (25 μ Ci in 6 h) the ratio of the specific activities of glycine and serine in the plasma was 0.263 at 6 h (assuming that specific activity

was at a plateau at this time) (Table 3, Fern and Garlick, 1974).

$$\text{So per cent of total glycine derived from serine} = [0.263 \times 3 \times 100] / 2 = 39.5\%$$

This calculated amount of glycine derived from serine assumes that the synthesis of glycine from serine takes place only by serine hydroxymethyltransferase and the 3-C of serine does not contribute to the glycine formation. However, it appears glycine synthase is not involved in glycine synthesis at least in muscle, kidney and brain (see section 4.13.). The synthesis of glycine from serine by glycine synthase has been reported in rat liver mitochondria, however, it does not appear to take part in glycine synthesis to any appreciable extent *in vivo* (Kikuchi, 1973).

2. Rate of glycine production

This can be calculated by the formula:

$$\frac{[\text{infusion rate of (U-}^{14}\text{C)glycine (dpm/min)}]}{[\text{glycine equilibrium specific activity in plasma (dpm/nmol)}]}$$

When (U-¹⁴C)glycine was infused, the specific activity of glycine in the plasma reached a plateau at 2 h. At this time the specific activity was 185 dpm/nmol (Fig.1, Fern and

Garlick, 1974). Labelled glycine (25 μ Ci) was infused in 2 h.

Glycine production rate = 3.57 mmol/24 h/100 g body wt.

This value obtained is higher than that (2.5 mmol/24 h/100 g body wt.) obtained by Arnstein and Neuberger (1953).

3. Amount of glycine derived from serine

This can be calculated by the following formula:

(fraction of glycine derived from serine \times glycine production rate)

$$= 0.395 \times 3.57 = 1.41 \text{ mmol/day/100 g body weight}$$

From the data of Wolff and Bergman (1972b) it is calculated that the glycine production in sheep is about 6.5 mmol/24 h/Kg body wt. (assuming weight of mature sheep, 50 Kg; Wt. of sheep used in Wolff and Bergman (1972b) has not been mentioned). In young men, the glycine production was 7.6 mmol/24 h/kg body wt (Robert *et al.*, 1982).

The above values obtained for the rate of glycine production in whole rat and sheep have been used in the following section to estimate the contribution of glycine released by muscle towards the glycine production by the whole body.

4.3. EFFLUX AND SYNTHESIS OF GLYCINE FROM ISOLATED MUSCLES

4.3.a. The rat hind-limb

The glycine efflux observed from the isolated hind-limb could arise from i) degradation of glutathione present in the muscle and erythrocytes, ii) 'leaching out' of intracellular muscle glycine, iii) degradation of bovine serum albumin in the muscle (muscle is known to be a site of albumin degradation (Yedgar et al., 1983)), iv) proteolysis of muscle protein, and v) *de novo* synthesis. The present study showed that neither degradation of muscle and erythrocyte glutathione nor 'leaching out' of intracellular muscle glycine gave rise to any significant amount of glycine release by the isolated perfused rat hind-limb; no significant changes either in the glutathione content of muscle and erythrocytes or the intracellular glycine concentration were observed over the perfusion period (Table 17 & 19). The glycine efflux was $28.37 \pm 1.8 \mu\text{mol}/3 \text{ h}/30 \text{ g}$ muscle (on using the standard perfusion medium, SPM), which formed 11% of the total amino acid efflux. Since glycine comprises only 4% of total residues in muscle protein and there is no evidence of a specific labile glycine-rich protein in muscle (Komiz et al., 1954; section 3.11.f.), synthesis of glycine in perfused hind-limb must be taking place. Furthermore, the increase in the rate of glycine efflux on using serine in the perfusion medium and the observed decrease in the rate of glycine efflux on

addition of 5-formyl tetrahydrofolate, a specific inhibitor of serine hydroxymethyltransferase (SHMT) (Barman, 1969) (see sections 3.4.b. & 3.4.c.) do not suggest the production of glycine from any glycine-rich protein of muscle. After accounting for the glycine resulting from proteolysis of muscle protein and bovine serum albumin, the isolated rat hind-limb synthesised a minimum of $12.27 \mu\text{mol glycine}/3 \text{ h}/30 \text{ g muscle}$, which formed about 43% of the total glycine released. While the present study was carried out, another report appeared (Ebisawa *et al.*, 1983) which also showed a small neogenesis of glycine ($1.5 \mu\text{mol}/\text{h}/100 \text{ g muscle}$) from isolated perfused rat hind-limb. However, it is difficult to compare the two results, as unlike the present study Ebisawa *et al.* (1983) starved the rats for 24 h before perfusion. In addition the composition of perfusion medium was different. Addition of glycine to the blood by the hindquarters of rat (Bronsan *et al.*, 1983) and sheep (Heitmann and Bergman, 1980) and also by the human forearm (Pozetsky *et al.*, 1969) has been reported. In addition, muscle is shown to be quantitatively the most important site of glycine synthesis in *Caiman latirostris* (Coulson and Hernandez, 1967).

From the data of Fern and Garlick (1974) it was calculated that glycine is produced in the rat at a rate of $3.57 \text{ mmol}/24 \text{ h}/100 \text{ g body wt.}$ (see section 4.2.). In the present study, glycine produced from rat hind-limb on using 0.2 mM serine (near the plasma serine concentration, see section 3.4.b.) was $37.84 \mu\text{mol}/3\text{h}/30\text{g muscle}$. If glycine is produced by the hind-limb at the same rate as *in vivo*, the

contribution of muscle towards total glycine production by the rat would be about 13% (assuming that the muscle comprises about 45% of body weight). This is the minimum amount which is contributed by the muscle as the glycine could be utilised for the synthesis of various substances in muscle. Recently, *de novo* synthesis of purines in muscle has been demonstrated (Sheehan and Tully, 1983).

4.3.b. The sheep diaphragm

The results showed that the degradation of muscle glutathione or 'leaching out' of intracellular muscle glycine did not give rise to any glycine released by the isolated perfused sheep diaphragm, as no change in both the glutathione content of muscle and intracellular glycine concentration was observed before and after the perfusion (Table 32 & 34). The total release of glycine from the sheep diaphragm on using the standard perfusion medium was $16.54 \pm 1.9 \mu\text{mol}/3 \text{ h}/30 \text{ g}$ muscle. After accounting for the glycine resulting from proteolysis of muscle protein and bovine serum albumin, the isolated sheep diaphragm synthesised a minimum of $10.29 \mu\text{mol}$ glycine/ $3 \text{ h}/30 \text{ g}$ muscle, which formed about 62% of the total glycine released.

From the data of Heitmann and Bergman (1980), the glycine synthesised by sheep hindquarters can also be calculated by taking into account the tyrosine efflux and glycine to tyrosine ratio in muscle protein. The calculations have been presented in Table 55. The synthesis of glycine ($\mu\text{mol}/3 \text{ h}/30 \text{ g}$ muscle) from sheep hindquarters

Table 55. Calculation of glycine synthesis by sheep hindquarters from the data of Heitmann and Bergman (1980)

<u>Net hindquarters metabolism (mmol/h)</u>			
	<u>Fed</u>	<u>Fasted</u>	<u>Acidotic</u>
	Added*	Added*	Added*
Glycine	0.85 ± 0.14	1.88 ± 0.27	0.93 ± 0.26
Tyrosine	0.08 ± 0.04	0.24 ± 0.03	-0.03 ± 0.09

*, added to the blood

Glycine released due to proteolysis =

Release of tyrosine x glycine to tyrosine ratio in muscle (as tyrosine is not metabolised in muscle)

(Glycine to tyrosine ratio in muscle is 3:1)

Glycine synthesised =

Total glycine released - glycine released due to proteolysis

Glycine synthesised in fed condition = $0.85 - (0.08 \times 3) = 0.61$ mmol/h (4.58 μ mol/3 h/30 g muscle)

Glycine synthesised in fasted condition = $1.88 - (0.24 \times 3) = 1.16$ mmol/h (8.7 μ mol/3 h/30 g muscle)

Glycine synthesised in acidosis = $0.93 + (0.03 \times 3) = 1.02$ mol/h (7.65 μ mol/3 h/30 g muscle)

(The weight of muscle from which the above quantities were added to the blood was 12 Kg, E. Bergman personal communication)

under different conditions was as follows: fed, 4.6; fasted, 8.7; acidotic, 7.65). In the present study the minimum synthesis of glycine from rat hind-limb was 12.27 $\mu\text{mol}/3\text{ h}/30\text{ g}$ muscle and for the sheep diaphragm it was 10.29 $\mu\text{mol}/3\text{ h}/30\text{ g}$ muscle. Therefore, on the basis of the above, it appears that both release and synthesis of glycine from rat hind-limb, sheep diaphragm and sheep hind-limb are in the order rat hind-limb > sheep diaphragm > sheep hind-limb. Of course the data has been obtained using different techniques and the influence of these techniques is difficult to assess. Fasting and acidosis increased the efflux and synthesis of glycine from sheep hindquarters (Heitmann and Bergman, 1980; Table 55).

Total glycine production by sheep was 6.5 mmol/day/Kg body wt. (see section 4.2.). By taking the glycine production by sheep diaphragm to be 19.35 $\mu\text{mol}/3\text{h}/30\text{g}$ muscle (obtained in the present study on using 0.2 mM serine in the perfusion medium), the contribution of muscle towards total glycine production was about 24% (assuming muscle comprises about 30% of body weight).

From above, it is concluded that glycine released by muscle contributes significantly to the total glycine production by the whole rat or sheep.

4.4. GLYCINE FORMATION FROM SERINE IN RAT HIND-LIMB AND SHEEP DIAPHRAGM

The higher rate ($P < 0.01$) of glycine efflux from the perfused rat hind-limbs on using the 'standard perfusion medium' (SPM) containing 0.2 mM serine as compared to that with SPM alone, and the increase ($P < 0.01$) in the rate of glycine efflux on addition of serine (5 mM) after 75 min of perfusion, suggested that serine is a substrate for glycine in muscle (see sections 3.4.a. & 3.4.b.). In sheep diaphragm, the mean rate of glycine efflux also increased on addition of 0.2 mM serine to the SPM, although this increase was not statistically significant ($P > 0.05$). Similarly, addition of 0.2 mM serine did not significantly increase the total glycine efflux, although the mean value was higher when 0.2 mM serine was added to the SPM (see sections 3.12.a. & 3.12.b.). These results suggested that there was a conversion of serine to glycine in sheep diaphragm, but the conversion was not very efficient. Further, serine to glycine conversion in sheep diaphragm appeared to be much smaller than that in rat hind-limb, as in the perfused rat hind-limbs addition of 0.2 mM serine significantly stimulated the rate of glycine efflux and there was a significant increase in the total efflux of glycine (see sections 3.4.a. & 3.4.b.).

After 3 h perfusion of the rat hind-limb, a total of 35% of initial serine radioactivity left in serine suggested that 65% of the added serine was metabolised in the muscle in 3 h. A total of 21.61% of initial serine radioactivity was recovered in glycine (see section 3.6.c.). Since 1 carbon is lost when serine is converted to glycine (SHMT reaction) this is equivalent to about 32% of the original serine radioactivity. From this data it is calculated that about 49% of serine metabolised in muscle is converted into glycine. This is the minimum estimate of serine converted to glycine as some glycine is utilised in muscle for purine synthesis (Sheehan and Tully, 1983; Brosh *et al.*, 1982) and a small amount is also oxidised in muscle (Manchester, 1965; Golgberg and Odessey, 1972; Beatty *et al.*, 1974). The rest of the serine metabolised probably goes to the formation of cysteine, aspartate, alanine, glutamate + glutamine and methionine (label was recovered in these amino acids from labelled serine, see section 3.6.a.). A simultaneous synthesis of serine in rat hind-limb also appears to take place since the specific activity of ($U-^{14}C$)serine decreased with time in the perfusion medium (83% in 3 h, see section 3.6.d.). This could explain higher release of glycine from muscle than the uptake of serine observed by other workers (Pozefsky *et al.*, 1976; Felig, 1981; Brosnan *et al.*, 1983) and the higher neogenesis of glycine than the catabolism of serine recorded in rat muscle (Ebisawa *et al.*, 1983).

About 35-40% of glycine released in the perfusion medium of the rat hind-limb is synthesised from serine (see section 3.6.e.). However, it is conceded that this value may be an underestimate as the specific activity of the precursor in the perfusion medium decreased with time (see section 3.6.d.). In the whole rat also about 40% of total glycine released originated from serine (from the data of Fern and Garlick, 1974; see section 4.2.).

The studies with cold serine had previously suggested that the serine to glycine conversion in sheep muscle was not as effective as that of the rat. This suggestion was confirmed with the studies using ^{14}C -serine. Only 3.25% of the original label in serine was found in glycine (\approx to 4.88% of the original serine radioactivity, see above). This corresponds to about 14% of the original serine metabolised (about 34% of serine was metabolised in sheep diaphragm, see section 3.14.e.). As mentioned above for rat hind-limb, this value may be the minimum estimate of the serine metabolised which is converted to glycine). The rest of the serine metabolised could go to the formation of cysteine, aspartate, alanine, glutamate + glutamine and methionine (as the label was also recovered in these amino acids in the sheep diaphragm; see section 3.14.a.). A simultaneous synthesis of serine in muscle could also take place in the sheep diaphragm as the specific activity of (U- ^{14}C)serine decreased in perfusion medium with time (36% in 3 h, see section 3.14.c.). This might explain the higher release of

glycine observed from the muscle of sheep than the uptake of serine (Heitmann and Bergman, 1980). The synthesis of serine in muscle could take place from glucose or muscle glycogen. However, unlike rat hind-limb no label was incorporated into serine from (U- 14 C)glucose in sheep diaphragm (see section 3.13.).

In sheep diaphragm, about 2.5-4% of total glycine efflux appears to originate from serine (see section 3.14.d.). Again it may be noted that this value is an approximate estimate of serine to glycine conversion, as the specific activity of added (U- 14 C)serine decreased as the perfusion progressed. In the whole sheep about 11% of total glycine released is derived from serine (Wolff and Bergman 1972b).

The results suggested: i) the degradation of serine in sheep diaphragm is lower than that in rat hind-limb, ii) the per cent of the metabolised serine converted to glycine is higher in rat hind-limb than in sheep diaphragm, iii) the radioactive experiments confirmed the results obtained using cold serine in the perfusion medium, that serine to glycine conversion in sheep diaphragm is lower than that in rat hind-limb, and iv) the per cent of glycine derived from serine in rat hind-limb and sheep diaphragm appeared to be the similar order of magnitude to the values observed in the entire rat and sheep.

4.5. PATHWAYS OF GLYCINE SYNTHESIS FROM SERINE IN MUSCLE

In the rat hind-limb, addition of 5-Formyl tetrahydrofolate, a specific inhibitor of serine hydroxymethyltransferase (SHMT) at a concentration of 2.5 mM inhibited the rate of glycine efflux by 36%. Glycine synthesis decreased by about 28% in presence of the inhibitor (section 3.4.c.). In the sheep diaphragm, a decrease of about 25% was observed in the rate of glycine efflux on addition of the inhibitor (section 3.12.c.). These observations suggested that serine hydroxymethyltransferase is taking part in the conversion of serine to glycine in both rat hind-limb and sheep diaphragm. It may be noted that 5-formyl tetrahydrofolate can be converted to tetrahydrofolate in the tissues. The enzyme, N-formylglutamate : THF transformylase catalysing this reaction has been reported in hog and rat liver (Blakely, 1969).

In mammalian liver, the synthesis of glycine is known to take place not only by SHMT but also by glycine synthase— a reverse of glycine cleavage reaction. There is a formation of 2 moles of glycine from one mole of serine by combination of the reactions catalysed by SHMT and glycine synthase.

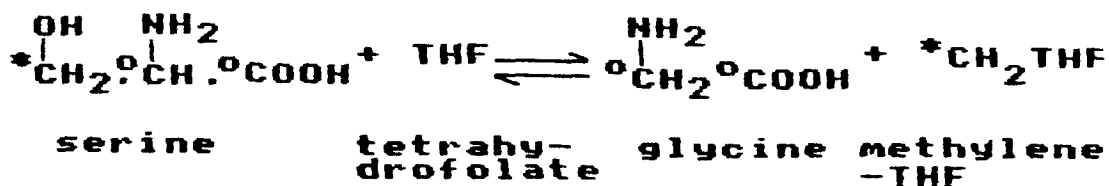

----- (I)

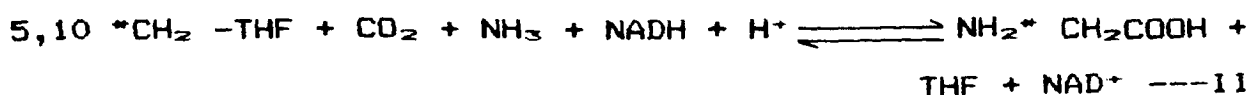

The first reaction is catalysed by SHMT and the second by an enzyme complex called glycine synthase (Kikuchi et al., 1980). In addition, glycine can be synthesised from serine by the following reaction (Ando et al., 1968):

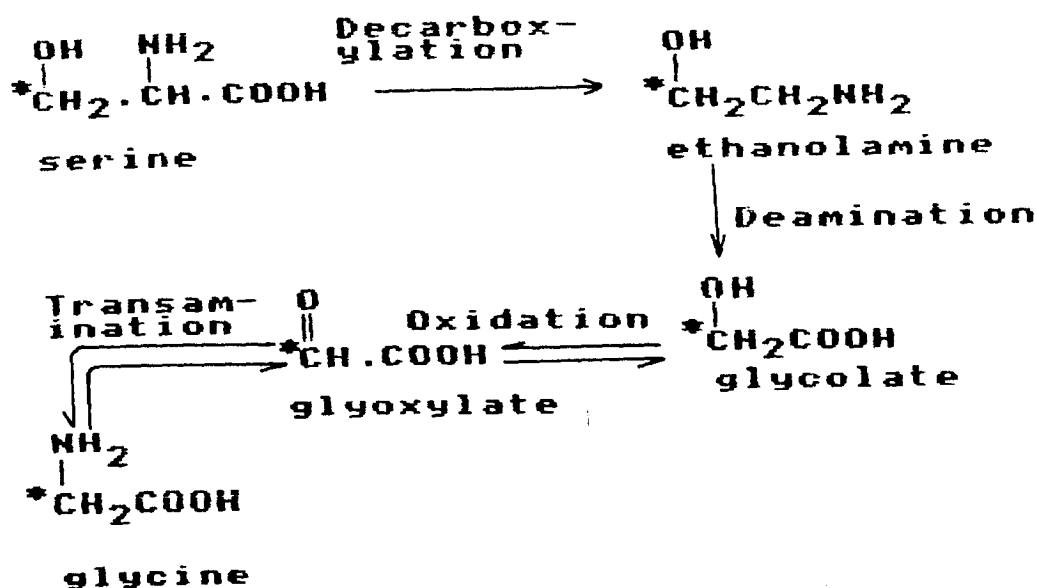

Radiolabelled glycine obtained following perfusion with (U- ^{14}C)serine together with the increase in the rate of glycine efflux on addition of 0.2 mM serine (near the plasma concentration of serine) and the decrease in rate of glycine efflux on addition of 5-formyl tetrahydrofolate to the perfusion medium provide evidence of glycine synthesis from serine *in vivo* in rat hind-limb. Patridge et al. (1982) also showed the conversion of (U- ^{14}C)serine to radioactive glycine in cultured rat skeletal cells. (U- ^{14}C)serine incorporation studies, considered in isolation, provide evidence for the presence of SHMT activity in muscle. However, they do not show whether the normal conversion is from serine to glycine or *vice versa*. SHMT catalysis a

freely reversible reaction and there could be exchange of isotope without any net conversion of serine to glycine. (Aqvist (1951) showed that ^{15}N is readily transferred from glutamate to branched-chain amino acids (BCAAs) and vice versa in rat, but there is no net synthesis of these BCAAs). During the present study no radioactive glycine was obtained following perfusion with (3- ^{14}C)serine. This suggested that in rat hind-limb, the formation of glycine from serine was only by reaction I (catalysed by SHMT) and not by reaction II (catalysed by glycine synthase). The presence of SHMT in muscle extract has been demonstrated (Yoshida and Kikuchi, 1973). The labelling of methionine (see section 3.6.a.) indicated that in muscle the methylene-THF pool was being labelled by reaction I to enable glycine to be labelled from (3- ^{14}C)serine had reaction II been operative.

The radioactivity in C-1 and C-2 of glycine isolated following perfusion with (U- ^{14}C)serine was almost equal, which also suggested that the conversion of serine to glycine was by SHMT and not by glycine synthase (see reaction I and II; had reaction II been operative, the radioactivity in C-2 should have been greater than that in C-1). The equal radioactivity in C-1 and C-2 of glycine also suggested that there was no exchange of the glycine carboxyl with CO_2 which is catalysed by P-protein and modulated by H-protein of glycine synthase (Kikuchi et al., 1980). Consistent with these observations is the negligible exchange reaction between the carboxyl group of glycine and bicarbonate observed in rat muscle extract by Yoshida and

Kikuchi (1973). A high exchange activity was recorded in liver and kidney of the rat (Yoshida and Kikuchi, 1973).

In addition, absence of labelled glycine following perfusion with (3-¹⁴C)serine suggested that glycine synthesis from serine via ethanolamine and glyoxylate (reaction III) is also not of physiological significance.

Similar results were observed for the sheep diaphragm. These results suggested that serine to glycine conversion takes place by serine hydroxymethyltransferase and not by glycine synthase. Also glycine synthesis from serine via glyoxylate (reaction III) does not appear to be of any physiological significance. Furthermore, there is no exchange of glycine carboxyl with CO₂.

4.6. EFFECT OF BRANCHED-CHAIN KETO ACIDS (BCKAs) ON GLYCINE SYNTHASE IN RAT HIND-LIMB AND SHEEP DIAPHRAGM

BCKAs activate glycine synthase in liver by about 4-fold (O'Brien, 1978). When the perfusions were done using (3-¹⁴C)serine the label was not transferred to glycine. The 3-C of serine is transferred to glycine by glycine synthase. In the previous perfusions, (section 3.6.a.), the perfusion medium did not contain branched-chain amino acids (BCAAs). The only source of BCKAs was the degradation of muscle protein BCAAs. So the concentration of BCKAs could be expected to be lower than that *in vivo*. Therefore, the perfusions were conducted following addition of the BCKAs to the perfusion medium containing (3-¹⁴C)serine. In presence

of the BCKAs, again no label was transferred to glycine, suggesting that there was still no synthesis of glycine from serine by glycine synthase in either rat hind-limb or sheep diaphragm. The label incorporated into methionine (section 3.7. & 3.15.) suggested that the muscle had the activity to release 3-C of serine as active 'one-carbon' units. This again gives confidence that glycine synthase is not operating in either of the muscles.

4.7. GLYCINE AND SERINE FORMATION FROM GLUCOSE IN RAT HIND-LIMB AND SHEEP DIAPHRAGM

The production of labelled alanine and glutamine from (U-¹⁴C)glucose by muscle has already been reported (Grubb, 1976; Odessey et al., 1974; Manchester and Young, 1959). Based on the specific activity of precursor glucose in the medium at start of the perfusion and that of alanine at 3 h of perfusion, it was found that about 25% of alanine released by the perfused rat hind-limb was derived from the exogenous glucose. Slightly higher values, 29% in the rat diaphragm and 33% in the perfused rat hind-limb have been reported (Grubb, 1976; Odessey et al., 1974). The presence of radioactivity in serine, and to a small extent in glycine, is interesting to note. In mammals there are few sources of 'one-carbon' units apart from serine and glycine, and quantitatively the most important pathway for generating 'one-carbon' units is the synthesis of serine and glycine

from carbohydrate (Blakely, 1969). The muscle appears to be a site of biogenesis of 'one-carbon' units from glucose. There are two pathways (Fig. 27) by which biosynthesis of serine from glucose takes place: i) from D-glycerate, called 'non-phosphorylated' pathway and ii) from 3-phosphoglycerate and called 'phosphorylated' pathway, both arising from glycolysis (Neuberger, 1981; Blakely, 1969; Evered, 1981). The relative contribution of these pathways differs from tissue to tissue (Walsh and Sallach, 1966). However, no information is available for muscle. A common feature of both the pathways is that the nitrogen of the serine formed is derived from amino acids— glutamate, glutamine and alanine (Blakely, 1969; Walsh and Sallach, 1966). Whatever be the pathway of serine biosynthesis in muscle, the nitrogen of serine would be derived from these amino acids. Furthermore, in muscle the nitrogen of alanine, glutamine and glutamate is derived from the catabolism of other amino acids (Ruderman, 1975). This suggests that the nitrogen of glycine released from muscle may be derived from the catabolism of amino acids, and the carbons from glucose or muscle glycogen. In a number of bacteria as well, glycine derives its amino group from glutamate (Umbarger, 1981). Thus glycine, like alanine and glutamine, can also act as a nitrogen carrier from muscle to other organs. This is substantiated by the observation that a large increase in the release of amino nitrogen from rat hind-limb takes place in acidosis, and after glutamine, glycine forms the major part of nitrogen release from the hind-limb. Moreover,

'Phosphorylated'
pathway

'Non-phosphorylated'
pathway

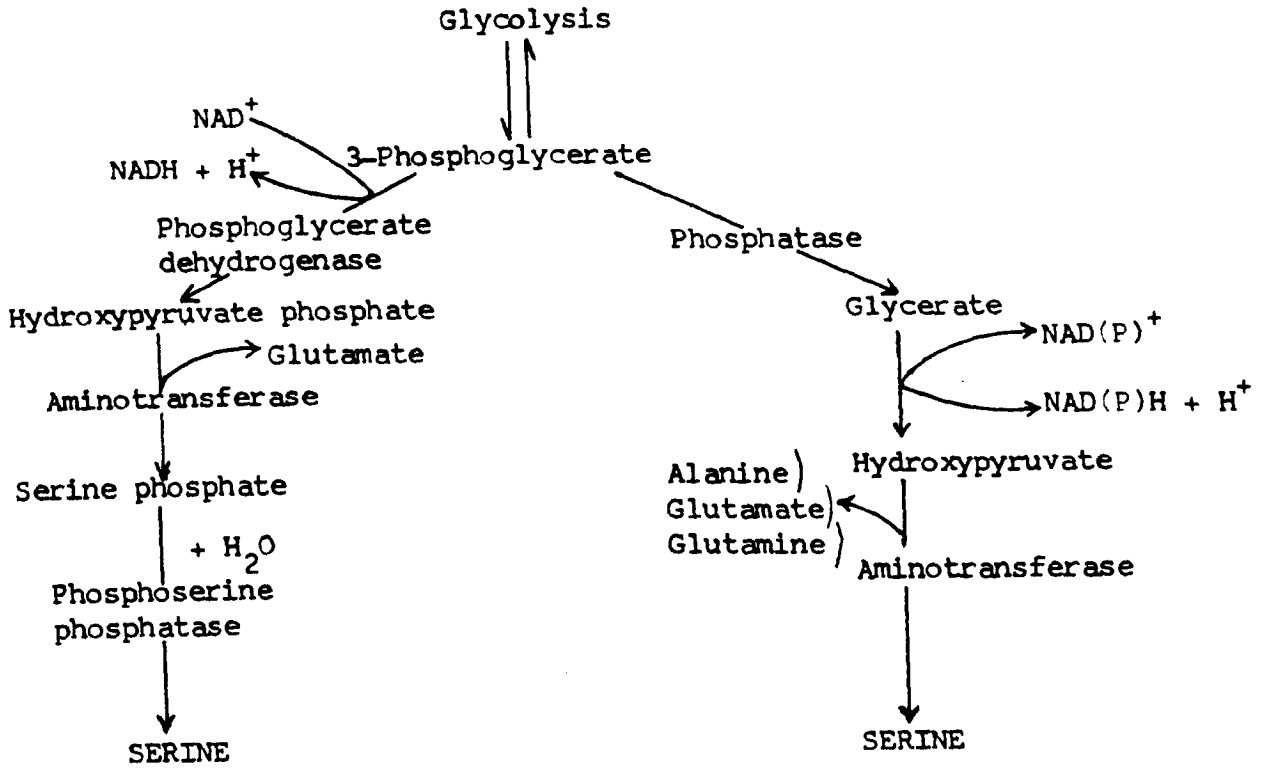

Fig. 27 Pathways of serine biosynthesis

(from Blakley, 1969)

glycine is extracted by the rat kidney (Goldstein et al., 1980) and derivation of ammonia intrarenally from glycine has been demonstrated (Pitts and Pilkington, 1966).

In sheep diaphragm, the results obtained were similar to those for the rat hind-limb, except that no radioactivity was detected in serine or glycine following perfusion with (U- 14 C)glucose. The serine to glycine conversion is not very efficient in sheep diaphragm (see section 4.4.). In addition, glucose is poorly utilised by the ruminant muscle (Lindsay and Buttery, 1980). Therefore, generation of 'one-carbon' units from glucose via serine would be expected to be very low in sheep diaphragm.

In sheep diaphragm, it was shown that about 4.2% of total alanine efflux comes from exogenous glucose. This value is quite close to the 5.2% obtained by Coward and Buttery (1982). However, this value for sheep diaphragm is much lower than the value of 25% found in the present study for rat hind-limb.

4.8. INCORPORATION OF LABEL FROM (U- 14 C)SERINE AND (3- 14 C)SERINE INTO AMINO ACIDS IN RAT HIND-LIMB AND SHEEP DIAPHRAGM

Label was recovered in glycine, methionine, cystine, aspartate, alanine, and glutamate and glutamine. The transfer of label to glycine has been dealt with in the previous sections (4.4 & 4.5.). The specific activities of

labelled amino acids obtained after perfusion with (U-¹⁴C)serine and (3-¹⁴C)serine were consistent with the pathways of serine metabolism (shown below) known to occur in a number of tissues (Meister, 1965). The higher specific activity of any amino acid in the medium following perfusion of rat hind-limb as compared to that obtained from perfused sheep diaphragm does not necessarily imply a higher rate of incorporation of label from serine to that particular amino acid in rat hind-limb as compared to that in sheep diaphragm and vice versa. Several factors may affect the specific activity. One such factor is the pool size of serine and the intermediates in the two tissues, on which no data is available. In addition, different rates of release of amino acids into the medium due to proteolysis could affect the specific activities (in perfused rat hind-limb the rate of proteolysis was approximately 2 times that in perfused sheep diaphragm, as judged by the efflux of tyrosine; see Table 14 & 31). Therefore, no effort has been made to come to any conclusion on the comparative rates of transfer of serine carbons to the amino acids in the tissues.

4.8.a. Incorporation of label into aspartate and alanine

The higher specific activities of aspartate than those of alanine both in rat hind-limb and sheep diaphragm were interesting to note (Table 23 & 39).

Serine dehydratase is not present in muscle (Yoshida and Kikuchi, 1973) therefore incorporation of label from serine into alanine and aspartate could not be via the

pyruvate synthesised from serine by this enzyme. The other known pathway (b) of serine catabolism is via the formation of hydroxypyruvate by a serine aminotransferase. Oxaloacetate and hence aspartate could be formed from hydroxypyruvate by the sequence of reactions mentioned in Fig. 28. The reactions: serine \longrightarrow hydroxypyruvate \longrightarrow glycerate \longrightarrow 2-phosphoglycerate take place in mitochondria (Rowell et al., 1972, 1982a). 2-Phosphoglycerate appears to move to the cytosol (Snell, 1975; Beliveau and Freeland, 1982a) and is converted into phosphoenolpyruvate by the enzyme phosphopyruvate hydratase. The phosphoenolpyruvate formed is converted to oxaloacetate by phosphoenolpyruvate carboxykinase which is known to be present in muscle (Snell and Duff, 1985). Aspartate aminotransferase which is also present in the cytosol (Snell and Duff, 1985) converts oxaloacetate to aspartate. Pyruvate could also be formed from phosphoenolpyruvate in cytosol by pyruvate kinase (Snell and Duff, 1985) and this pyruvate, originating as a result of pathway (b), could give rise to labelled alanine. The higher specific activity of aspartate as compared to that of alanine suggested that the flux of phosphoenol pyruvate was higher towards oxaloacetate and aspartate than it was towards pyruvate. Probably, the enzyme activity of pyruvate kinase was lower than that of phosphoenolpyruvate carboxykinase and cytosolic aspartate aminotransferase.

The higher specific activity of aspartate also suggested that in both ruminant and non-ruminant muscle the catabolism of serine by a serine aminotransferase was higher

Fig. 28 Formation of alanine and aspartate from serine

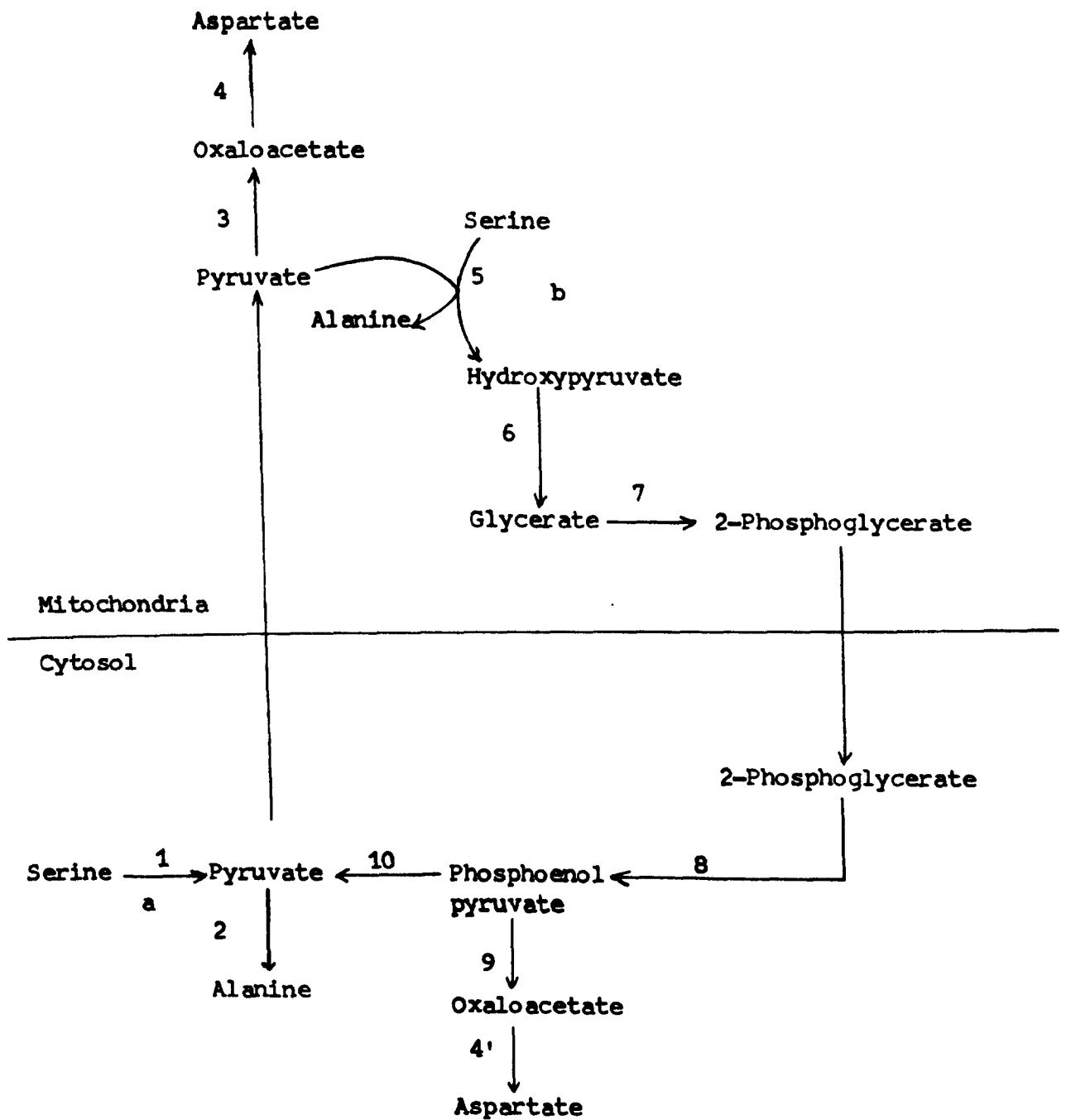

1. Serine dehydratase (EC 4.2.1.13)
2. Alanineaminotransferase (EC 2.6.1.2)
3. Pyruvate carboxylase (EC 6.4.1.1)
4. Mitochondrial aspartate aminotransferase (EC 2.6.1.1)
- 4'. Cytosolic aspartate aminotransferase (EC 2.6.1.1)
5. Serine aminotransferase (EC 2.6.1.51)
6. D-glycerate dehydrogenase (EC 1.1.1.29)
7. Glycerate kinase (EC 2.7.1.31)
8. Phosphopyruvate hydratase (EC 4.2.1.11)
9. Phosphoenolpyruvate carboxykinase (EC 4.1.1.32)
10. Pyruvate kinase (EC 2.7.1.40)

than that by serine dehydratase. Had the major catabolic pathway for serine been by serine dehydratase, the specific activity of alanine should have been higher than that of aspartate. These observations throw light on the route by which serine could be converted into glucose in muscle *in vivo*. Glycogen synthesis from serine in the isolated perfused hindquarters of acutely uraemic rats has been demonstrated (Djovkar *et al.*, 1983). The label was recovered in aspartate and alanine from both (U- ^{14}C)serine and (3- ^{14}C)serine. This observation does not suggest the incorporation of label from serine to aspartate and alanine via conversion of serine to glycine and then to glyoxylate, as the label was not transferred to glycine from (3- ^{14}C)serine.

4.8.b. Incorporation of label into methionine

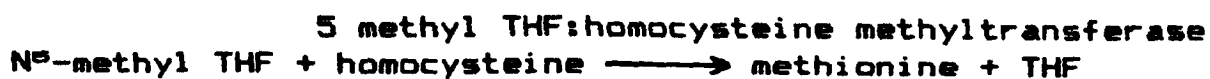
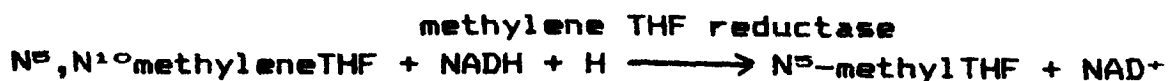
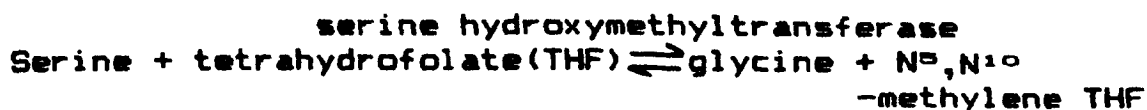

Theoretically, the specific activity of methionine obtained following perfusion with (3- ^{14}C)serine should be 3 times that of the methionine obtained following perfusion with (U- ^{14}C)serine with the same specific activity ($\mu\text{Ci}/\mu\text{mol}$). In rat hind-limb the ratio of specific activity was 2.85, very close to the theoretical value. For perfused

sheep diaphragm, the specific activity of methionine from (3-¹⁴C)serine was higher than that of the methionine obtained from (U-¹⁴C)serine, but the ratio of specific activities (1.75) was much lower than the theoretical value. The reason for this appeared to be the large variation in the results obtained, as is evident from the standard error (Table 39). The variability of results from ruminant muscles appears to be greater than that from non-ruminant muscle (Coward, 1978; Lindsay et al., 1976; Wolff and Bergman, 1972b). In light of the observation of Xue and Snoswell (1985) that the activity of 5-methyltetrahydrofolate-homocysteine methyl transferase in sheep muscle is 2.5 times that of rats, it is interesting to note almost the equal specific activities of methionine in perfused rat hind-limb and sheep diaphragm despite a substantially lower conversion of serine to glycine and 'one-carbon' units in sheep diaphragm.

The conversion of homocysteine to methionine in muscle by homocysteine methyltransferase besides, incorporating 3-C of serine, would regenerate tetrahydrofolate in muscle. The results of Yoshida and Kikuchi (1973) suggest that tetrahydrofolate could also be regenerated in muscle by sequential actions of methylene tetrahydrofolate dehydrogenase, cyclohydrolase and 10-formyl tetrahydrofolate: NADP⁺ oxidoreductase. The amount of tetrahydrofolate in the tissues is very limited (Blakely, 1969; Krebs and Hems, 1975), free tetrahydrofolate must be regenerated in tissues for carrying out a number of important reactions. Muscle does not degrade to any significant extent the carbon skeleton of methionine (Goldber and Chang, 1978).

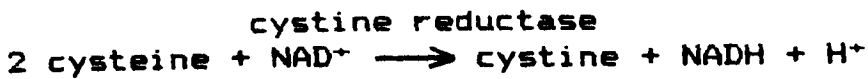
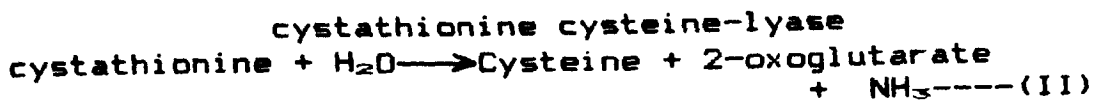
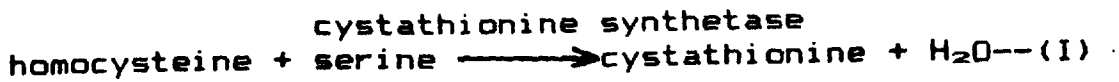
4.8.c. Incorporation of label into cysteine

The net effect of reactions I and II is an exchange of the sulfhydryl group of homocysteine with hydroxyl group of serine in a process termed *transsulfuration*. Thus in biosynthesis of cysteine the carbon chain, including the amino group, arises from serine, whereas sulfur is derived from methionine. Radcliffe and Egan (1974) could not demonstrate the activity of cystathionine γ -lyase (EC 4.4.1.1) (formerly known as L-homoserine hydrolyase (EC 4.2.1.15) in skeletal muscle of goat, neonatal lambs, lambs, sheep, calves and steers. In rat skeletal muscle they did not determine the enzyme activity. However, the present results suggested that this enzyme was present both in rat hind-limb and sheep diaphragm. It could be that the activity of cystathionine γ -lyase in ruminant muscle was very low and was below the limit of detection of the assay used by Radcliffe and Egan (1974).

4.8.d. Incorporation of label into glutamate and glutamine

The transfer of label from serine to glutamate and hence to glutamine appears to take place by conversion of serine to oxaloacetate (as mentioned above) and then the conversion of the latter to 2-ketoglutarate by citric acid cycle enzymes. 2-Ketoglutarate is transaminated to glutamate.

oxaloacetate \longrightarrow citrate \longrightarrow 2-ketoglutarate \longrightarrow
glutamate

Glutamine is synthesised in muscle from glutamate by glutamine synthetase (Ruderman, 1975; Smith et al., 1984).

Although the enzymes capable of catalysing the above reactions have been demonstrated in tissue extracts, evidence that similar reactions occur *in vivo* is indirect and moreover these studies are limited to only liver. The present study demonstrated that these reactions also occur in both ruminant and non-ruminant muscle. Since these results are obtained using the perfused organ technique, it is safe to conclude that the above reactions exist in muscle *in vivo*.

4.9. GLYCINE SYNTHESIS FROM THREONINE IN RAT HIND-LIMB AND SHEEP DIAPHRAGM

In rat 20-33% of dietary threonine is degraded to glycine (Meltzer and Sprinson, 1952). Threonine can be

converted to glycine in tissues by threonine aldolase (L-threonine \longrightarrow glycine + acetaldehyde; EC 4.1.2.5) and by the coupled activities of threonine dehydrogenase (L-threonine + NAD⁺ \longrightarrow 2-amino-3-oxobutyrate + NAD + H⁺; EC 1.1.1.103) and 2-amino-3-oxobutyrate CoA-ligase (2-amino-3-oxobutyrate + CoA \longrightarrow glycine + acetyl-CoA; EC 2.3.1.29) (Bird and Nunn, 1983; Bird et al., 1984). Until recently, it was often assumed that the activity of hepatic threonine aldolase accounts for the synthesis of glycine from threonine observed in rat. However, the activity of aldolase is very low in rat liver and 90% of threonine catabolised in normally fed state is through threonine dehydrogenase (Bird and Nunn, 1983). Recently, Bird et al. (1984) have shown that glycine formation from threonine in the rat is primarily by the coupled activities of threonine dehydrogenase and 2-amino-3-oxobutyrate CoA-ligase. However, in the chicken, the activity of threonine aldolase in both liver and muscle is much higher than that of threonine dehydrogenase (Davis and Austic, 1982).

The present results showed that there was a synthesis of glycine from threonine in both the rat hind-limb and sheep diaphragm, as radiolabelled glycine was obtained following perfusion with (U-¹⁴C)threonine. However, the conversion of threonine to glycine was very small. From the specific activities of threonine and glycine in the medium it was calculated that only about 0.2% of glycine released by the perfused rat hind-limb was derived from threonine (see section 3.9.a.). This value for the sheep diaphragm was 0.4% (see section 3.17.a.). It may be noted that these are

approximate estimates of the glycine derived from threonine. The results of the present study (see section 3.9. & 3.17) suggested: i) threonine was a poor precursor for glycine synthesis as compared to serine in both rat hind-limb and sheep diaphragm, ii) threonine might be a better precursor for glycine synthesis in sheep diaphragm as compared to rat hind-limb, iii) degradation of threonine in both rat hind-limb and sheep diaphragm was lower than that of serine, and iv) the catabolism of threonine in sheep diaphragm was lower than that in rat hind-limb. However, a higher per cent of the threonine metabolised in sheep diaphragm was converted to glycine.

4.10. EFFECT OF BRANCHED-CHAIN KETO ACIDS (BCKAs) ON THE METABOLISM OF GLYCINE IN RAT HIND-LIMB AND SHEEP DIAPHRAGM

The experiments using BCKAs in the perfusion medium were not designed to study the effects of BCKAs on the metabolism of glycine or any other amino acids (see sections 3.10.a. & 3.15.). However, the changes in the efflux and intracellular concentrations of amino acids were estimated, as these could provide valuable information on the role of amino acids in nitrogen transport from muscle; the addition of BCKAs would create a state of nitrogen deficiency in muscle due to their conversion to branched-chain amino acids by the transaminases.

In rat hind-limb, the perfusion with BCKAs significantly increased the efflux as well the intracellular

amino acid concentration of valine, isoleucine and leucine (Table 29 & 30). In perfused sheep diaphragm there was a significant increase in the efflux as well as the intracellular concentration of isoleucine and leucine following perfusion with BCKAs (Table 47 & 48). The efflux as well as the intracellular concentration of valine increased but the increase was not significant ($P > 0.05$). The results suggested an increase in the synthesis of valine, isoleucine and leucine in both perfused rat hind-limb and sheep diaphragm from BCKAs, obviously by transaminases. On the other hand, there was a significant decrease in the efflux of glutamine and alanine from both the perfused rat hind-limb and sheep diaphragm on perfusion with BCKAs. The glycine efflux decreased from both the rat hind-limb (about 25%) and sheep diaphragm (about 28%). However, for both the muscles, the decrease was not statistically significant. This non-significant decrease in the glycine efflux could be attributed to the presence of 0.2 mM serine in the medium (see sections 3.7. & 3.15.) i.e. simultaneous synthesis of glycine from added serine, and the large variation in the results obtained (see section 3.18.a.). Similar changes have been observed in the plasma amino acid concentrations when BCKAs were infused in female subjects. There was increase of leucine, isoleucine and valine and decrease of serine, glycine, alanine, threonine and methionine; however, there was no change in glutamine (Sapir and Walser, 1977). The observed decrease in the efflux of methionine from the sheep diaphragm could be due to transamination of BCKAs by methionine (Harper et al., 1984).

The results suggested that the synthesis of glutamine, alanine and glycine in muscle is a nitrogen dependent process and they transport nitrogen from muscle to other organs. The role of alanine and glutamine as a vehicle for nitrogen transport from muscle is well known (Lindsay and Buttery, 1980; Ruderman, 1975). The present results confirm this and suggest that glycine could also play a part in the process.

4.11. SERINE TO GLYCINE CONVERSION IN RAT AND SHEEP TISSUES

Serine hydroxymethyltransferase (SHMT) activity was estimated in liver, diaphragm and hind-limb muscle of both rat and sheep (Table 49 & 50). It has been shown in section 3.19. that glycine synthesis observed from the perfused organs was much lower than that calculated from *in vitro* SHMT activities. Therefore, the estimation of glycine synthesis from serine in the rat diaphragm and sheep hind-limb using the activities of SHMT in the corresponding tissues may not represent the values expected *in vivo*. However, the SHMT activities would indicate the relative rates in which serine is converted into glycine in these tissues. Also the activities would allow a comparison of the capacity of muscle and liver for the conversion of serine into glycine.

Both in rat and sheep the enzyme activity was in the order liver > diaphragm > hind-limb muscle. Also the

activity of SHMT in diaphragm and hind-limb muscle of rat was higher than the values in corresponding tissues of sheep. In addition, SHMT activity of rat hind-limb muscle was greater than that of sheep diaphragm ($0.056 \pm 0.003(8)$ units/g wet wt or $302.4 \pm 16.2(8)$ $\mu\text{mol}/3 \text{ h}/30 \text{ g}$ muscle; sheep diaphragm $0.04 \pm 0.003(9)$ unit/g wet wt. or $216 \pm 16.2(9)$ $\mu\text{mol}/3 \text{ h}/30 \text{ g}$ muscle). It is concluded that *in vivo*, the rate of conversion of serine to glycine (and also the synthesis of 'one-carbon' units from serine) could be expected to be in the order rat diaphragm > rat hind-limb > sheep diaphragm > sheep hind-limb.

The SHMT activity of sheep liver was about 4 times that of rat liver (Table 49 & 50). In sheep liver the contribution of glycine to glucose is low (Wolff and Bergman, 1972a). So the high rate of conversion of serine to glycine in sheep liver may be associated with the higher need of glycine for conjugation of bile salts and for detoxification of the phenylalanine end products, benzoic acid and phenylacetic acid to form hippurate and phenaceturate (Heitmann and Bergman, 1980).

In sheep, 5-methyltetrahydrofolate-homocysteine methyltransferase plays a significant role in hepatic methionine synthesis. In contrast, in the rat hepatic system methionine synthesis is virtually dependent on betaine-homocysteine methyltransferase (Xue and Snowswell, 1985). On the basis of these observations Xue and Snowswell have suggested that sheep are adapted to low activity of hepatic betaine-homocysteine methyltransferase by means of raising the 5 - methyltetrahydrofolate - homocysteine methyltrans-

ferase activity in order to maintain the physiological level of methionine for various methylations. High activity of SHMT in sheep liver as compared to that in rat liver is consistent with the suggestion. It is interesting to note that the activity of methylene-tetrahydrofolate dehydrogenase (which converts methylene-tetrahydrofolate to methenyl-tetrahydrofolate, Fig. 2) is also higher in sheep liver as compared to that in rat liver (Kikuchi, 1973).

4.11.a. Capacity of serine to glycine conversion of liver and muscle

i) Rat

The approximate weight of the liver of a rat weighing about 225 g is 9.42 g (Bird and Nunn, 1983) and that of the skeletal muscle is 90-113 g (as skeletal muscle weight comprises about 40-50% of total body weight). In a rat weighing about 225 g, total capacity of liver for serine to glycine conversion is about $9.42 \times 2.47 = 23.27 \mu\text{mol}/\text{min}$, whereas that of skeletal muscle is 90×0.056 to 113×0.056 i.e. 5.04 to 6.33 $\mu\text{mol}/\text{min}$ (the values were obtained for the gastrocnemius muscle, as this can be taken as indicative of skeletal muscle as a whole (Waterlow et al., 1978)). Therefore, the maximum capacity of skeletal muscle for serine to glycine conversion is 22-27% of that of liver.

ii) Sheep

In a sheep the relative weight of the muscle is about 20-fold that of liver (Xue and Snoswell, 1985). Hence the total capacity of muscle for serine to glycine conversion is about 4% ($0.021 \times 20 \times 100/10.88$) of that of liver.

4.12. SYNTHESIS OF GLYCINE IN RAT UNDER VARIOUS METABOLIC CONDITIONS

4.12.a. Trenbolone acetate (TBA) treatment

Serine hydroxymethyltransferase (SHMT) activity increased in the liver, diaphragm and hind-limb muscle of TBA treated rats. This suggested that glycine synthesis by muscle of the TBA treated rats is higher than that of the control rats, as in the rat, the majority of glycine is synthesised from serine by SHMT (see sections 4.4. & 4.5.). The increase in muscle SHMT activity explains the higher intracellular muscle concentration of glycine observed in the TBA treated rats by Vernon and Buttery (1978) and also the higher efflux of glycine observed from the perfused rat hind-limbs of TBA treated rats (Vernon, 1977).

The physiological role of SHMT is not only the interconversion of serine and glycine but is the generation of 'one-carbon' units in the form of 5,10-methylene-tetrahydrofolate. Considerable indirect evidence suggests that generation of 'one-carbon' units is the primary role of SHMT (Schirch, 1982). 'One-carbon' units are required in the biosynthesis of purines, thymidylate, methionine, lipids etc. (see Fig. 2). Increased supply of folic acid stimulated renal growth with a concomitant increase in RNA and DNA synthesis of the tissue (Kremzner and Cote, 1968). It is well known that RNA, DNA, and protein synthesis are folate-dependent processes (Marchetti et al., 1980). The

de novo synthesis of purines in muscle has recently been demonstrated (Sheehan and Tully, 1983).

4.12.b. Testosterone treatment

SHMT activity increased in liver, diaphragm, and hind-limb muscle after testosterone treatment. The synthesis of glycine and 'one-carbon' units in muscle would increase as a result of this increase in the enzyme activity. Sanborn *et al.* (1975) showed that, when testosterone stimulates growth in its target organ, and there is a requirement for 'one-carbon' units and amino acids respectively for the synthesis of purines and protein; not only is SHMT activity increased, but also the enzymes of serine biosynthesis from glycolytic intermediates are stimulated. In male rats SHMT activity is known to decrease in the prostate on castration, and treatment with testosterone completely restores the activity to normal values. However, in the liver these treatments did not have any effect. Although castration and testosterone treatment did not have any effect on SHMT activity in liver, it did affect folate metabolism in the liver as well as the prostate (Rovinett *et al.*, 1972). In addition, testosterone increases the synthesis of serine by increasing the activity of 3-phosphoglycerate dehydrogenase, a key enzyme in the synthesis of serine in both liver and prostate (Sanborn *et al.*, 1975). The various biological effects of testosterone on liver and also the change in the activity of SHMT in muscle and liver observed in the present study both show that testosterone can affect different

metabolic processes not only in the accessory sex organs, which are recognised target organs, but also in other organs as well. The same appears to be true for estrogens (see below).

The level of activity of SHMT and the incorporation of (3-¹⁴C)serine into purine bases in the uterus has also been shown to increase after the estrogen treatment (Herranen and Mueller, 1956,1957). Jamdar and Greengard (1969) also reported effects of estrogen on another enzyme, phosphoserine phosphatase in another organ, the kidney.

The increase in activity of SHMT on TBA and testosterone treatment supports the theory (see Schirch, 1982) that in a tissue undergoing rapid growth an increased supply of 'one-carbon' units is required and they are generated by an increase in the activity of SHMT. Similar arguments have been put forward for the higher activity of SHMT observed in stimulated human lymphocytes (Haurani and Masse, 1977) and chronic lymphocytic leukemic patients (Thorndike et al ., 1979). The estimation of muscle SHMT activity could possibly be a test for determining the potency of anabolic agents. However, more research is required to explore this possibility.

Both TBA and testosterone acted similarly on the key enzyme of glycine and 'one-carbon' unit synthesis (SHMT), in contrast to their different effects on muscle protein turnover. The increase in muscle SHMT activity on TBA or testosterone treatment was consistent with the increase in RNA synthesis observed in muscle of both TBA and

testosterone treated rats (Breuer and Florini, 1966; Vernon and Buttery, 1978). However, the reduction in protein synthetic activity in muscle on TBA treatment is not entirely consistent with the concept of the activity of RNA (Millward et al ., 1975). In testosterone treated rats there is increase in protein synthetic activity in muscle (Martinez et al ., 1984).

i) Action of trenbolone acetate and testosterone on muscle serine hydroxymethyltransferase activity— some speculations

Androgen may act on muscle by aromatization to oestrogen (see Buttery, 1983). Administration of testosterone increases the specific activity of glucose-6-phosphate dehydrogenase in rat muscle and it has been proved that this effect is mediated by aromatization of testosterone to estradiol which exerts direct effect on muscle causing an increase in specific activity of glucose-6-phosphate dehydrogenase (Knudsen and Max, 1980). The increase in SHMT activity observed with both androgens (TBA and Testosterone) and with estrogen (Herranen and Mueller, 1956,1957) suggest that the effect on SHMT activity of TBA and testosterone could be an estrogen effect, presumably mediated by aromatization. However, it is difficult to see how TBA could be aromatised. This may be explored by conducting studies using TBA and testosterone in conjunction with estrogen and androgen antagonists and selective androgen aromatase inhibitor (Knudsen and Max,

1982). The activities of androgen aromatase is quite high in muscle (MaDonald et al., 1971) and muscle possesses receptors for both testosterone and estrogen (see Knudsen and Max, 1980; Olsen et al., 1977; Dahlberg, 1982; Dionn et al., 1979; Sinnett-Smith et al., 1983; Krieg, 1976; Dube et al., 1976). However, it may be noted that all the effects of testosterone are not mediated by aromatization to estrogen (Powers and Florini, 1975; Shields, 1978).

SHMT is a regulatory enzyme and its activity is regulated by a number of metabolites like 5-formyl-tetrahydrofolate, 5-methyltetrahydrofolate, glycine, NAD⁺, NADH, NADPH etc. (Krebs and Hems, 1975; Ramesh and Rao, 1978, 1980). Hormones (insulin, cortisol, tri-iodothyroxine) are known to change the redox state (NADH and NAD⁺ content) of muscle (Aoki et al., 1977; Tomos et al., 1979; Goldberg et al., 1980). It is quite likely that, at a molecular level one of the factors controlling the activity of SHMT is mediated via changes in the concentrations of NAD⁺ and NADH. The other point of regulation of SHMT by TBA and testosterone in muscle could be at the level of enzyme synthesis. In prostate and liver, testosterone is suggested to regulate the activity of enzymes of serine and 'one-carbon' metabolism (including SHMT) at the level of enzyme synthesis (Sanborn et al., 1975).

4.12.c. Protein deficiency

Neogenesis of glycine and catabolism of serine increases in the hind-limbs of protein deficient rats (Ebisawa *et al.*, 1983). A decrease in RNA and protein synthesis in muscle, liver and heart of rats on protein-deficient diets has been reported (Millward *et al.*, 1974; Cooper *et al.*, 1969; Wannemacher *et al.*, 1971). In addition, it is interesting to note that the activities of the enzymes of serine biosynthesis increase in the liver of protein-deficient rats (Fallon *et al.*, 1966). On the basis of these observations it is tempting to speculate that there could be an accelerated synthesis of serine and its increased conversion to glycine and 'one-carbon' units in muscle of protein-deficient rats; and probably the increased supply of glycine and 'one-carbon' units act towards repletion of RNA, DNA, protein and methionine, as glycine and 'one-carbon' units take part in the synthesis of purine, thymidylate, protein and methylation of homocysteine to methionine. In addition, in protein deficiency the activity of branched-chain amino transferases decreases (Mimura *et al.*, 1968; Adibi *et al.*, 1975), thereby increasing the availability of branched-chain amino acids (BCAAs). The increased availability of BCAAs could also act towards repletion of protein, as BCAAs and particularly leucine is known to increase the protein synthesis (Fulks and Goldberg, 1975; Buse and Reid, 1975; Buse and Weigand, 1977; Li and

Jefferson, 1977; Buse et al., 1979). The increase in the specific activity of hepatic 5-methyl tetrahydrofolate-homocysteine methyltransferase, which forms methionine is also observed in protein deficiency (Finkelstein et al., 1971).

4.12.d. Starvation and diabetes

Ruderman et al. (1974) did not observe any significant increase in the efflux of glycine from the hind-limbs of 48 h starved or diabetic rats. These observations suggest that SHMT activity of the muscle does not change in starvation or diabetes.

4.12.e. Control of serine metabolism in rat muscle — an hypothesis

The present study showed that testosterone and trenbolone acetate (TBA) treatment increased the SHMT activity of rat muscle. The SHMT activity does not appear to change in starvation or diabetes. There are several examples of regulation of the enzymes of serine and 'one-carbon' unit metabolism (including SHMT) by the sex steroids, not only in their target organs, but also in the liver and kidney. The regulation of serine and 'one-carbon' unit metabolism has also been shown in states like fasting and diabetes (Sanborn et al., 1975). In rat liver the activity of serine dehydratase and serine:pyruvate transaminase increases in fasting and diabetes (Sallach et al., 1972). So it is

tempting to speculate that at least in rat, a fine regulatory mechanism could exist in muscle for the metabolism of serine. Whenever there is a need for the synthesis of nucleic acids and protein, SHMT activity increases, whereas in fasting and diabetes when glucose is required, the activity of serine dehydratase and serine:pyruvate transaminase increases. (Serine is converted to pyruvate by the former and to hydroxypyruvate by the latter; hydroxypyruvate is ultimately converted to 2-phospho-D-glycerate). However, information about the effect of diabetes and starvation on the activities of serine dehydratase and serine:pyruvate transaminase in muscle are necessary for proof of this hypothesis. Furthermore, it would be interesting to investigate the synthesis *de novo* of serine in muscle in conditions such as testosterone and TBA treatment in light of the observations of Sanborn et al. (1975) and Snell (1980), who showed that in liver, whenever there is increased need of 'one-carbon' units and glycine, the biosynthesis of serine from glycolytic intermediates increases.

4.13. ROLE OF GLYCINE SYNTHASE (EC 2.1.2.10) IN GLYCINE BIOSYNTHESIS

In the present context it is worth quoting Neuberger (1981), "A very important question which is still unresolved is, how far the glycine cleavage system is used for the synthesis of glycine". From the information available from

the present study in muscle together with the information available in the literature on glycine synthase in different organs, it may be possible to attempt to answer this question. The present study has shown that glycine synthase does not take part in glycine synthesis in muscle. The synthesis of glycine from serine by glycine synthase has been reported in rat liver mitochondria; however, it does not appear to take part in glycine synthesis to any appreciable extent *in vivo* (Kikuchi, 1973). In central nervous system, there is a *de novo* synthesis of glycine. However, the synthesis by glycine synthase does not appear to be important (Aprison and Daly, 1978). Glycine is not synthesised in the kidney; instead it is converted to serine (Rowell et al., 1982b; Pitts et al., 1970; Lowry and Brosnan, 1983; Lowry et al., 1985).

On the basis of this information, it appears that glycine synthase (reverse of glycine cleavage system) does not take part to any significant extent in the synthesis of glycine in the rat.

The role of glycine synthase in the synthesis of glycine in sheep is not clear. The present study has shown that there is no synthesis of glycine by this pathway in sheep muscle. In sheep liver, glycine synthase does not appear to be active to any appreciable extent (Kikuchi, 1973). However, information on glycine synthesis by glycine synthase in other organs is not available. Unlike in the rat, there is a large addition of glycine to the blood by sheep kidney (Heitmann and Bergman, 1980), the origin of which is not known.

4.14. 'SERINE - GLYCINE' CYCLE—AN HYPOTHESIS

The release of glycine from human and rat muscle *in vivo* is accompanied by the removal of serine (Felig et al., 1970; Aikawa et al., 1973; Brosnan et al., 1983). The present study showed that rat muscle synthesises glycine mainly from serine by serine hydroxymethyltransferase (SHMT). An uptake of glycine and release of serine is observed in the rat, dog and human kidney under normal as well as under various other metabolic conditions (Brosnan et al., 1983; Seitz et al., 1977; Squires et al., 1976; Oven and Robinson, 1963; Pitts and MacLeod, 1972). In the rat kidney serine is mainly formed from glycine by the coupled action of the glycine cleavage complex and SHMT (reaction I & II, Fig. 29) (Rowell et al., 1982b). The significance of formation of serine in the kidney from glycine appears to be conservation of 'one-carbon' units generated from 2-C of glycine by the glycine cleavage complex (reaction I, Fig. 29), which is known to occur in kidney (Rowell et al., 1982b; Kikuchi, 1973). This reaction appears to incorporate nitrogen from glycine into urinary ammonia in the kidney (Pitts and Pilkington, 1966) besides generating energy in the form of ATP (Jackson and Golden, 1981). Thus it appears that glycine while acting as a carrier of nitrogen from muscle to kidney, also helps as a generator of 'one-carbon' units in the kidney. These

Fig. 29 'Serine-glycine' cycle — an hypothesis

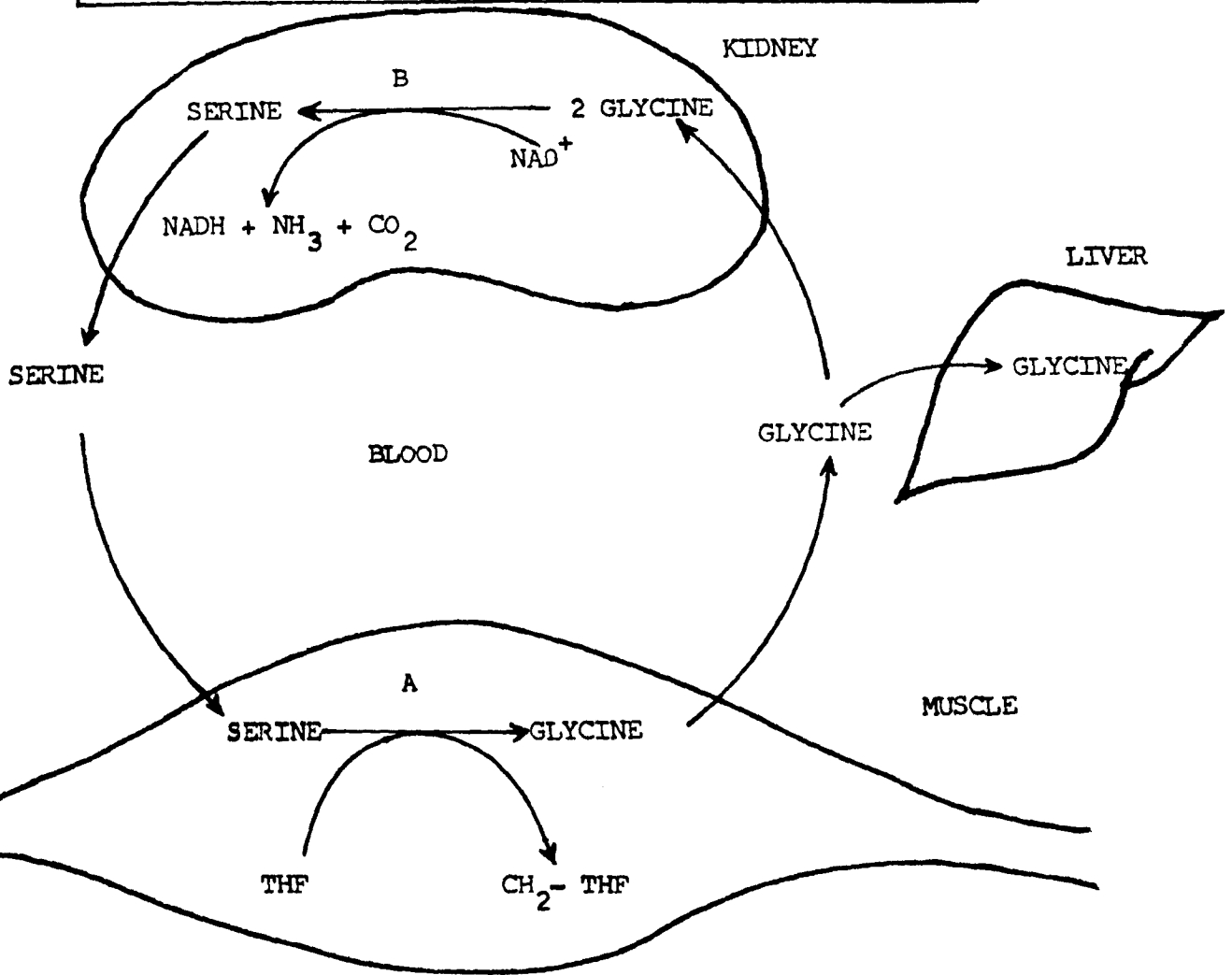
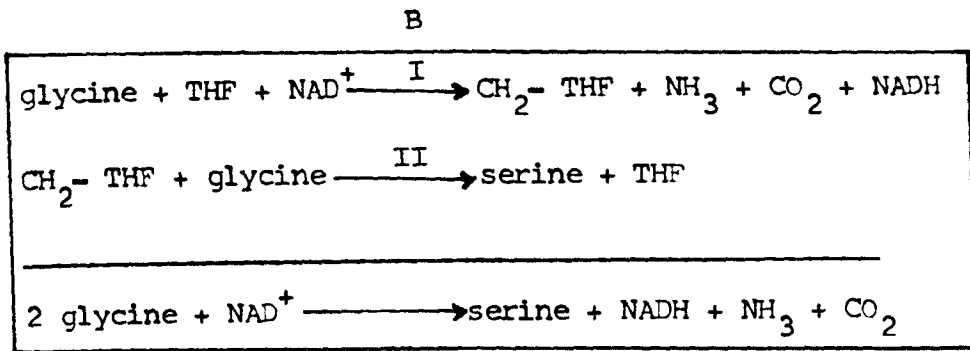

A catalysed by serine hydroxymethyltransferase (EC 2.1.2.1)

B catalysed by coupled action of glycine cleavage system(I). (EC 2.1.2.10) and serine hydroxymethyltransferase(II)

'one-carbon' units are added to the blood by the kidney in the form of 3-C of serine (3-C of serine originates from 2-C of glycine by the coupled action of glycine cleavage complex and SHMT). The 3-C of serine can yield 'one-carbon' units in other tissues.

It is thus tempting, at least in the rat, to propose the existence of 'serine-glycine' cycle; serine is converted to glycine and 'one-carbon' units in muscle by SHMT, and the glycine after its transportation to the kidney is converted to serine by the combined action of the glycine cleavage system and SHMT. The significance of this cycle, as mentioned above, appears to be the transport of nitrogen from muscle to kidney and generation of 'one-carbon' units in muscle. The function of muscle in serine to glycine conversion does not appear to be primarily nitrogen transportation from muscle. Since glycine synthesis is by SHMT only, one N is exported per serine consumed unlike coupled action of SHMT and glycine synthase which yields two glycine molecules per serine. The coupled action of SHMT and glycine synthase does not produce any extra 'one-carbon' units. The suggestion that muscle appears to be an important site of 'one-carbon' unit production is consistent with the results of Brosh et al. (1982) who showed that skeletal muscle is a major site of *de novo* purine synthesis. The results from trenbolone acetate or testosterone treated rats obtained in the present study (see section 4.12.) also support the suggestion that muscle plays an important role

in the synthesis of 'one-carbon' units.

Because the serine to glycine conversion in sheep diaphragm is much lower, it is difficult to be so confident about proposing a 'serine-glycine' cycle involving kidney and muscle in sheep. Unlike rat kidney, there is a release of both serine and glycine from the sheep kidney; however, the release of glycine from sheep muscle is accompanied by removal of serine (Heitmann and Bergman, 1980). More research is needed before the cycle is proposed in the sheep.

4.15. POSSIBLE PHYSIOLOGICAL SIGNIFICANCE OF GLYCINE RELEASED BY THE MUSCLE

The direct cleavage of glycine by the glycine cleavage system constitutes the most significant pathway of glycine catabolism in the rat (Yoshida and Kikuchi, 1970). The activity of this enzyme system is very low in muscle (Yoshida and Kikuchi, 1973) and so is the oxidation of glycine (Manchester, 1965; Goldberg and Odessey, 1972; Beatty *et al.*, 1974). This may have some rationale, i.e. use of glycine for various synthetic processes. In addition, 'one-carbon' units generated along with the glycine take part in various synthetic processes in the body. The utilisation of glycine and 'one-carbon' units in muscle for purine synthesis has been demonstrated (Sheehan and Tully, 1983). To what extent glycine, and 'one-carbon' units

synthesised in muscle are used there or exported to other organs is not known. The glycine efflux from muscle could contribute towards the synthesis of glucose, purines, creatine, porphyrin, glutathione and be used for conjugation of bile acids and other toxic substrates in the liver (glycine is taken up by rat liver, Brosnan et al., 1983; Yamamoto et al., 1974). It also acts as a carrier of nitrogen to the kidney and is used for generation of energy and 'one-carbon' units in this organ.

From the present study, the origin of glycine released by the sheep muscle is not entirely clear. It has been shown that serine to glycine conversion is very low in sheep muscle; therefore, the synthesis of glycine is not accompanied by the synthesis of the same amounts of 'one-carbon' units in sheep muscle as rat muscle. Glycine release from sheep hindquarters increases in fasting and acidosis as does the removal of glycine by liver (Heitmann and Bergman, 1980). Glycine released by the sheep muscle may be used for glucose production, conjugation of bile salts and also the detoxification of the phenylalanine end products, phenylacetic acid and benzoic acid to form aceturate and hippurate in the liver. Glycine released by the sheep muscle appears only to transport nitrogen to the liver and not to the kidney, as sheep kidneys release glycine (Heitmann and Bergman, 1980).

4.16. ORIGIN OF GLYCINE IN RAT AND SHEEP MUSCLE

Glycine synthesis from serine and threonine has been studied. In the rat hind-limb, about 35-40% of the total glycine released was derived from serine and only about 0.2% from threonine. Glycine released due to proteolysis formed about 44% of the total glycine efflux. Although these values are an approximate estimate of glycine derived from the different sources, the results do suggest that glycine in rat muscle is synthesised mainly from serine. In sheep diaphragm, about 4% of the total glycine released was derived from serine. Threonine contributed only 0.4% of the total glycine release, and the proteolysis of the muscle formed about 30%. The origin of the rest of glycine released (about 65%) from the sheep diaphragm is not known. The other source of glycine in rat hind-limb and sheep diaphragm could be glyoxylate (In rat muscle, L-alanine-glyoxylate-aminotransferase activity is absent, Rowsell et al., 1969; however, no information is available for sheep muscle. A glutamate-glycine transaminase with high activity has been demonstrated in pigeon breast muscle, D'Abramo and Tomazos, 1959). The sources of glyoxylate could be glutamate (Rowsell et al., 1975), ascorbate and hydroxyproline (Neuberger, 1981; Rowsell et al., 1972; see Lowry et al., 1985), hydroxypyruvate and isocitrate (Aprison and Daly, 1978) and citrate (Rowsell et al., 1972). (Fig. 30).

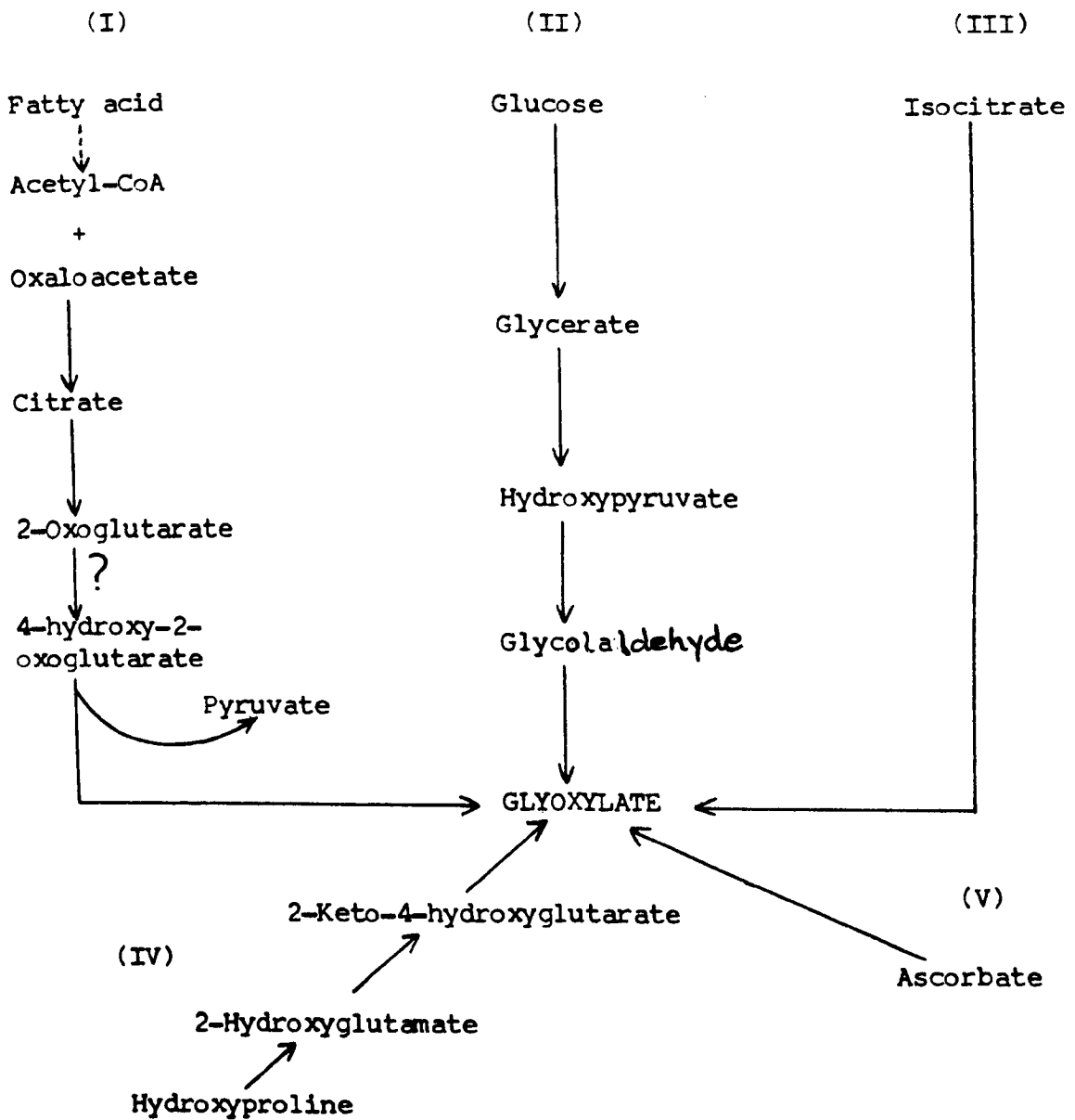

Pathway (I) from Rowsell et al (1972)

Pathway (II) & (III) from Aprison and Daly (1978)

Pathway (IV) & (V) from Meister (1965) & Lowry et al (1985)

Fig. 30 Sources of glyoxylate

The observed lower synthesis of glycine from serine (per unit weight of tissue) in sheep diaphragm as compared to that in rat hind-limb may be due to the difference in the body weight of the rat and the sheep—the metabolic rate per unit body weight of big mammal is lower than that of small mammal. Furthermore, in sheep diaphragm, a lower per cent of the total glycine synthesised was derived from serine. This may be a reflection of lower glucose utilisation by ruminants and a lower rate of glucose uptake by ruminant muscle as compared to that of rat (Buttery, 1979). The rat hind-limb comprises 82% muscle and the rest is skin and adipose tissue (Vernon, 1977), whereas the sheep diaphragm is almost 100% muscle. The big difference observed in serine to glycine conversion between rat hind-limb and sheep diaphragm could not be entirely due to the difference in the composition of the two tissues. The results obtained from the whole body studies showing that the per cent of the total glycine produced which is derived from serine is much higher in the whole rat than in the whole sheep (see sections 4.2. & 4.4) gives further confidence to the data obtained on muscle metabolism from the perfused rat hind-limb and sheep diaphragm preparations.

Almost the same amount of glycine is synthesised by the sheep and rat muscles ($12.3 \mu\text{mol}/3 \text{ h}/30 \text{ g}$ muscle, section 3.3.d.; $10.3 \mu\text{mol}/3 \text{ h}/30 \text{ g}$ muscle, section 3.11.e. respectively). The rate of glycine synthesis in ruminant muscle from carbohydrate is lower. These together with the

observation that the rate of glucose uptake and glucose utilisation by ruminant muscle is lower than that of rat muscle, suggest that ruminant muscle is adapted to a low rate of glycine production from carbohydrate by means of raising the activity of some other pathways of glycine synthesis (via glyoxalate ?) in order to maintain the levels of glycine necessary for various synthetic processes and for the transport of nitrogen. The same could be the case for the synthesis of 'one-carbon' units in ruminant muscle.

4.17. POSSIBLE EXTENSIONS OF THE PRESENT STUDY

The present study has raised more questions than it has answered. The results of the study are likely to foster more research in the following fields.

1. The role of muscle as a site of 'one-carbon' unit synthesis (hitherto, it is accepted that in mammal, liver tissue is the main site of *de novo* 'one-carbon' unit synthesis).
2. The existence of 'serine-glycine' cycle involving kidney and muscle and the significance of the cycle under different physiological conditions.
3. The involvement of kidney in the regulation and metabolism of 'one-carbon' units under different physiological conditions.
4. The origin of glycine in ruminant muscle (which would give better insight into the physiological significance of

glycine synthesised by the ruminant muscle).

5. The action of trenbolone acetate and testosterone on muscle serine hydroxymethyltransferase and 'one-carbon' unit metabolism.

6. The regulation of metabolism at the site of serine in muscle.

7. The role of muscle in glycine synthesis for local use and/or for transport to other organs under different physiological conditions.

BIBLIOGRAPHY

Titles of journals are abbreviated in accordance with the *World List of Scientific Periodicals* (1963) (Brown, P. and Stratton, G.B., Eds.), 4th Edition, Butterworths, London and subsequent supplements.

- Adibi, S.A., Peterson, J.A., Krzysik, B.A. (1975) Modulation of leucine transaminase activity by dietary means. *Am. J. Physiol.* 228, 432-435
- Aikawa, T., Matsutaka, H., Takezawa, K. and Ishikawa, E. (1972) Gluconeogenesis and amino acid metabolism. *Biochim. Biophys. Acta* 279, 234-244
- Aikawa, T., Matsutaka, H., Yamamoto, H., Okuda, T., Isikawa, E., Kawano, T. and Matsumura, E. (1973) Gluconeogenesis and amino acid metabolism. II. Interorgan relations and role of glutamine and alanine in the amino acid metabolism of fasted rats. *J. Biochem.* 74, 1003-1017
- Akhtar, M., El-Obeid, H.A. and Jordan, P.M. (1975) Mechanistic, inhibitory and stereochemical studies on cytoplasmic and mitochondrial serine hydroxymethyltransferase. *Biochem. J.* 145, 159-168
- Ando, T., Nyhan, W.L., Gerritsen, T., Gong, L., Heiner, D.C. and Bray, P.F. (1968) Metabolism of glycine in the nonketotic form of hyperglycinemia. *Pediat. Res.* 2, 254-263
- Andrews, R.P. (1981) Protein Chemistry Notes. LKB 4400 Amino acid Analyser. Instruction manual. PCN 12
- Aoki, T.T., Toews, C.J., Rossini, A.A., Ruderman, N.B. and Cahill, G.F.Jr. (1975) Glucogenic substrate levels in fasting man. *Adv. Enzyme Reg.* 13, 329-336
- Aprison, M.H. and Daly, E.C. (1978) Biochemical aspects of transmission at inhibitory synapses: the role of glycine. *Adv. Neurochem.* 3, 203-294
- Aqvist, S. (1951) Metabolic interrelationships among amino acids studied with isotope nitrogen. *Acta Chem. Scand.* 5, 1046-1064
- Arnstein, H.R.V. and Neuberger, A. (1953) The synthesis of glycine and serine by the rat. *Biochem. J.* 55, 271-280
- Atkin, G.E. and Ferdinand, W. (1970) Accelerated amino acid analysis: studies on the use of lithium citrate buffer and the effect of n-propanol in the analysis of physiological fluids and protein hydrolysates. *Anal. Biochem.* 8, 313-329
- Ballard, F.J., Filsell, D.H. and Jarett, I.G. (1976) Amino acid uptake and output by the sheep hindlimb. *Metabolism* 25, 415-418

- Barak, A.J., Beckenhauer, H.C. and Tuma, D.J. (1971) A method for studying the uptake of creatine by a perfused hind limb preparation. *Can. J. Physiol. Pharmacol.* 49, 612-614
- Barman, T.E. (1969) *Enzyme Handbook*. Vol 2. Berlin, Springer-verlag.
- Barratt, E., Buttery, P.J. and Boorman, K.N. (1974) Urate synthesis in the perfused chick liver. *Biochem. J.* 144, 189-198
- Beatty, C.H., Curtis, S., Young, M.K. And Bocek, R.M. (1974) Oxidation of amino acids by red and white muscle fibre groups. *Am. J. Physiol.* 227, 268-272
- Beckerton, A. (1976) Protein turnover in sheep. *Ph.D Thesis*. University of Nottingham
- Beliveau, G. and Freedland, R. (1982a) Effect of starvation and diet composition on two pathways of L-serine metabolism in isolated rat hepatocytes. *J. Nutr.* 112, 686-696
- Beliveau, G. and Freedland, R. (1982b) Metabolism of serine, glycine and threonine in isolated cat hepatocytes *Felis domestica*. *Comp. Biochem. Physiol.* 71B, 13-18
- Bell, A.W., Gardner, J.W., Manson, W. and Thompson, G.E. (1975) Acute cold exposure and the metabolism of blood glucose, lactate and pyruvate, and plasma amino acids in the hind leg of the fed and fasted young ox. *Br. J. Nutr.* 33, 207-217
- Belzer, F.O., Ashby, B.S., May, R.E. and Dunphy, J.E. (1968) Isolated perfusion of whole organs. In *Organ perfusion and preservation* (Norman, J.C., Ed.), pp. 3-12, Appleton Century Croft N. York
- Berger, M., Hagge, S. and Ruderman, N.B. (1975) Glucose metabolism in perfused skeletal muscle, interaction of insulin and exercise on glucose uptake. *Biochem. J.* 146, 231-238
- Bergman, E.N. and Heitmann, R.N. (1978) Metabolism of amino acids by the gut, liver, kidneys and peripheral tissues. *Fed. Proc.* 37, 1228-1232
- Bergmeyer, U., Bernt, E., Grassl, M. and Michal, G. (1974) in *Methods in Enzymatic Analysis* (Bergmeyer, H.U., Ed.), 2nd Edition, vol 1, pp. 308-317, Academic Press, London

- Bernt, E. and Bergmeyer, U. (1974) in *Methods in Enzymatic Analysis* (Bergmeyer, H.U., Ed.) vol. 4, pp. 1643-1647, Academic Press, Inc. London
- Beutler, E., Duron, O. and Kelly, B.M. (1963) Improved method for the determination of blood glutathione. *J. Lab. Clin. Med.* 61, 882-888
- Bird, M.I. and Nunn, P.B. (1979) Glycine formation from L-threonine in isolated rat liver mitochondria. *Biochem. Soc. Trans.* 7, 1276-1277
- Bird, M.I. and Nunn, P.B. (1983) Metabolic homeostasis of L-threonine in the normally-fed rat. *Biochem. J.* 214, 687-694
- Bird, M.I., Lord, L.A.J. and Nunn, P.B. (1982) Catabolism of L-threonine in rat and human liver: importance of threonine dehydrogenase. *Biochem. Soc. Trans.* 10, 130
- Bird, M.I., Nunn, P.B. and Lord, L.A.J. (1984) Formation of glycine and aminoacetone from L-threonine by rat liver mitochondria. *Biochim. Biophys. Acta* 802, 229-236
- Blakely, R.L. (1969) In *The Biochemistry of Folic acid and Related Pteridines*. North-Holland Publishing Company, Amsterdam-London
- Block, R.J. and Weiss, K.W. (1956) Methods and results of protein analysis. *Amino Acid Handbook*, pp. 341-346, Springfield II. Thomas.
- Bloxam, D.L. (1971) Nutritional aspects of amino acid metabolism. I. A rat liver perfusion method for the study of amino acid metabolism. *Br. J. Nutr.* 26, 393-422
- Breuer, C.B. and Florine, J.R. (1966) Effect of ammonium sulfate, growth hormone and testosterone propionate on ribonucleic acid polymerase and chromatin activities in rat skeletal muscle. *Biochemistry* 5, 3857-3865
- Breuer, C.B. and Florini, J.R. (1965) Amino acid incorporation into protein by cell-free systems from rat skeletal muscle. IV. Effect of animal age, androgens, and anabolic agents on activity of muscle ribosomes. *Biochemistry* 4, 1544-1549
- Brosh, S., Boer, P., Zoref-shani, E. and Sperling, D. (1982) *De novo* purine synthesis in skeletal muscle. *Biochim. Biophys. Acta* 714, 181-183

- Cheng, M.S. and Schirch, L. (1973) Serine transhydroxymethylase. *J. Biol. Chem.* 248, 3631-3635
- Chochinov, R.H., Perlman, K. and Moorhouse, J.A. (1978) Circulating alanine production and disposal in healthy subjects. *Diabetes* 27, 287-295
- Clark, L.C.Jr., Wesseler, E.P., Miller, M.L. and Kaplan, S. (1974) Ring versus straight chain perfluorocarbon emulsions for perfusion media. *Microvasc. Res.* 8, 320-340
- Cleland, W.W. (1967) Enzyme kinetics. *Annu. Rev. Biochem.* 36, 77-112
- Cohen, B.E. and Folkman, M.J. (1968) Cell death and the measurement of oxygen consumption in the isolated perfusion organ. In *Organ Perfusion and Preservation* (Norman, J.C., Ed.), pp. 471-486, Appleton Century Crofts. N. York
- Cooper, W.K., Wannemacher, R.W.Jr. and Raica, N. Jr. (1969) Ribosomal quantity and quality and amino acid levels in muscles from hypophysectomized and protein-deficient rats. *Fed. Proc.* 28, 755 (abstr)
- Cornblath, M., Randle, P.J., Parmeggiani, A. and Morgan, H.E. (1963) Regulation of glycogenolysis in muscle. *J. Biol. Chem.* 238, 1592-1597
- Coulson, R.A. and Hernandez, T. (1967) Site of synthesis of amino acids in intact cayman. *Am. J. Physiol.* 213, 411-417
- Coward, B.J. (1978) Ruminant muscle metabolism. *Ph.D Thesis.* University of Nottingham.
- Coward, B.J. and Buttery, P.J. (1980) A perfused ruminant muscle preparation. *J. Agric. Sci.* 95, 7-16
- Coward, B.J. and Buttery, P.J. (1982) Metabolism of perfused ruminant muscle *J. Agric. Sci.* 98, 307-316
- Creese, R. and Northover, J. (1961) Maintenance of isolated diaphragm with normal sodium content. *J. Physiol. (London)* 155, 343-353
- Cross, D.L., Boiling, J.A., Ely, D.G. and Baker, J.P. (1974) Isolation-perfusion of ovine hindlimb. I. Development procedures. *J. Anim. Sci.* 39, 893-897

- Crouse, J.D., Smith, S.B. and Prior, R.L. (1984) Bovine muscle glycogen as affected by fasting and refeeding. *J. Anim. Sci.* 59, 384-387
- Cunningham, E.B. (1978) Mechanism of Metabolism. In *Biochemistry* McGraw-Hill Book Company, N. York
- Czok, R. and Lamprecht, W. (1974) Pyruvate, phosphoenolpyruvate and D-glycerate-2-phosphate. in *Methods Of Enzymatic Analysis* (Bergmeyer, H.U., Ed.) 2nd Edition, vol 3, pp. 1446-1451, Academic Press, N. York
- D'Abramo, F. and Tomazos, E. (1959) Distribution of glutamic-glyoxylic and glutamine-glyoxylic transaminases in animal tissues. *Ital. J. Biochem.* 8, 173
- D'Silva, J.L. and Neil, M.W. (1954) The potassium, water and glycogen content of the perfused liver. *J. Physiol. (London)* 124, 515-527
- Dahlberg, E. (1982) Characterization of the cytosolic estrogen receptor in rat skeletal muscle. *Biochim. Biophys. Acta* 717, 65-75
- Davis, A.T. and Austic, R.E. (1982) Threonine-degrading enzymes in chicken. *Poultry Sci.* 61, 2107-2111
- Dionne, F.T., Lessage, R.L., Dube, J.Y. and Tremblay, P.L. (1979) Estrogen binding proteins in rat skeletal and perineal muscles: *in vitro* and *in vivo* studies. *J. Steroid. Biochem.* 11, 1073-1080
- Djovkar, A., Hörl, W.H. and Heidland, A. (1983) Glycogen synthesis from serine in isolated perfused hindquarters of acutely uraemic rats. *Nephron* 34, 164-167
- Dohm, G.L., Kasperek, G.J., Tapscott, E.B. and Beecher, G.R. (1980) Effect of exercise on synthesis and degradation of muscle protein. *Biochem. J.* 188, 255-262
- Domingo, W.R. and Klyne, W. (1949) A Photoelectric flame photometer. *Biochem. J.* 45, 400-408
- Dube, J.Y., Lesage, R. and Tremblay, R.R. (1976) Androgen and estrogen binding in rat skeletal and perineal muscle. *Can. J. Biochem.* 54, 50-55
- Ebisawa, H., Yamoto, S., Yamamoto, T., Kishi, K. and Inoue, G. (1983) Effect of muscle amino acid metabolism on plasma free amino acids in normal and protein deficient adult rats. *Nutr. Rep. Int.* 27, 485-498

- Ellman, G.L. (1959) Tissue sulfhydryl groups. *Arch. Biochem. Biophys.* 82, 70-77
- Evered, D.F. (1981) Advances in amino acid metabolism in mammals. *Biochem. Soc. Trans.* 9, 159-169
- Exton, J.H. and Park, C.R. (1967) Control of gluconeogenesis in liver. *J. Biol. Chem.* 242, 2622-2636
- Fallon, H.J., Hackney, E.J. and Byrne, W.L. (1966) Serine biosynthesis in rat liver: regulation of enzyme concentration by dietary factors. *J. Biol. Chem.* 241, 4157-4167
- Felig, P. (1981) Inter-organ amino acid exchange. In *Nitrogen metabolism in man* (Waterlow, J.C. and Stephen, J.M.L., Eds.) Applied Science Publishers, London and North Jersey
- Felig, P. and Wahren, J. (1971) Amino acid metabolism in exercising man. *J. Clin. Invest.* 50, 2703-2714
- Felig, P., Pozefsky, T., Marliss, E., Cahill, G.F. Jr. (1970) Alanine: key role in gluconeogenesis. *Science* 167, 1003-1004
- Fern, E.B. and Garlick, P.J. (1974) The specific radioactivity of the tissues free amino acid pool as a basis for measuring the rate of protein synthesis in the rat *in vivo*. *Biochem. J.* 142, 413-419
- Finkelstein, J.D., Kyle, W.E. and Harris, B.J. (1971) Methionine metabolism in mammals. Regulation of homocysteine methyltransferase in rat tissue. *Arch. Biochem. Biophys.* 146, 84-92
- Frisell, W.R. and Mackenzie, C.G. (1958) The determination of formaldehyde and serine in biological systems. In *Method Biochemical Analysis* (Glick, D., Ed.) vol. 6, pp. 63-77, Interscience Publishers, Inc., N. York, London
- Fujioka, M. (1969) Purification and properties of serine hydroxymethylase from soluble and mitochondrial fractions of rabbit liver. *Biochim. Biophys. Acta* 185, 338-349
- Fulks, R.H., Li, J.B. and Goldberg, A.L. (1975) Effect of insulin, glucose and amino acids on protein turnover in rat diaphragm. *J. Biol. Chem.* 250, 290-298
- Garber, A.J., Karl, A.E. and Kipnis, D.M. (1976) Alanine and glutamine synthesis and release from skeletal muscle. I. Glycolysis and amino acid release. *J. Biol. Chem.* 251, 826-835

- Gerritsen, T., Waisman, H.A. (1978) Hypersarcosinemia. In The Metabolic Basis of Inherited Disease. 4th Edition (Stanbury, J.B., Wyngaarden, J.B., Fredrickson, D.S., Eds.), pp. 514, McGraw-Hill Book Co., N. York
- Glorieux, F.H., Scriver, C.R., Delvin, E. and Mohyuddin, F. (1971) Transport and metabolism of sarcosine in hypersarcosinemic and normal phenotypes. *J. Clin. Invest.* 50, 2313-2322
- Goldberg, A.L. and Chang, T.W. (1978) Regulation and significance of amino acid metabolism in skeletal muscle. *Fed. Proc.* 37, 2301-2307
- Goldberg, A.L. and Dice, J.F. (1974) Intracellular protein degradation in mammalian and bacterial cells. *Annu. Rev. Biochem.* 43, 835-869
- Goldberg, A.L. and Odessey, R. (1972) Oxidation of amino acids by diaphragm from fed and fasted rats. *Am. J. Physiol.* 223, 1384-1391
- Goldstein, L.H., Schrock, H. and Cha, C. (1980) Relationship of muscle glutamine production to renal ammonia metabolism. *Biochem. Soc. Tran.* 8, 509-510
- Good, C.A., Kramer, H. and Somogyi, M. (1933) The determination of glycogen. *J. Biol Chem.* 100, 484-491
- Goodman, M.N., Parrilla, R. and Toews, C.J. (1973) Influence of flourocarbon emulsions on hepatic metabolism in perfusate rat liver. *Am. J. Physiol.* 225, 1384-1388
- Griffith, D.W. and Meister, A. (1979) Glutathione: interorgan translocation, turnover, and metabolism. *Proc. Natl. Acad. Sci. U.S.A.* 76, 5606-5610
- Grubb, B. (1976) *De novo* synthesis of alanine by the perfused rat hind limb. *Am. J. Physiol.* 230, 1379-1384
- Hagge, W., Brodehl, J. and Gellissen, K. (1967) Hypersarcosinemia. *Pediat. Res.* 1, 409 (Abstr)
- Härdig, J. and Höglund, L.B. (1983) Seasonal and ontogenetic effects reared baltic salmon. *Comp. Biochem. Physiol.* 75A, 27-34

- Harper, A.E., Block, K.P., and Cree, T.C. (1983) Branched chain amino acids: nutritional and metabolic interrelationships. *4th International Symposium on Protein Metabolism and Nutrition* (European Association for Animal Production), vol 1, pp. 159-182, Clemont Ferrand, France.
- Harper, A.E., Miller, R.H., and Block, K.P. (1984) Branched-chain amino acid metabolism. *Annu. Rev. Nutr.* 4, 409-454
- Haurani, F.I. and Masse, A.T. (1977) Serine hydroxymethyltransferase and the stimulated human lymphocyte. *J. Reticulendo. Soc.* 21, 231-235
- Heitmann R.N. and Bergman E.N. (1980) Integration of amino acid metabolism in sheep: effects of fasting and acidosis. *Am.J Physiol.* 239, E250-254
- Heitmann, R.N., Hoover, A W.H. and Sniffen, C.J. (1973) Gluconeogenesis from amino acids in mature wether sheep. *J. Nutr.* 103, 1587-1593
- Hems, R., Stubbs, M. and Krebs, H.A. (1968) Restricted permeability of rat liver for glutamate and succinate. *Biochem. J.* 107, 807-815
- Herbert, V. and Das, K.C. (1976) The role of vitamin B12 and folic acid in hemato and other cell-poesis. In *Vitamins and Hormons* (Munson, P.L., Glover, J., Diczталusy, E. and Olson, R.E., Eds.) Academic Press, N. York
- Herranen, A. and Mueller, G.C. (1956) Effect of estradiol on the metabolism of serine-3-¹⁴C in surviving uterine segments. *J. Biol. Chem.* 223, 369-375
- Herranen, A. and Mueller, G.C. (1957) The effect of estradiol pretreatment on serinealdolase activity of rat uteri. *Biochim. Biophys. Acta* 24, 223-224
- Hider, R.C., Fern, E.B. and London, D.R. (1971) Identification in skeletal muscle of a distinct extracellular pool of amino acids and its role in protein synthesis. *Biochem. J.* 121, 817-827
- Hohorst, H.J. (1962) In *Methoden der Enzymatischen Analyse* (Bergmeyer, H.U., Ed.) 1st Edition, pp. 226, Verlag Cshemie, Weinheim
- Ichihara, A. and Koyama, E. (1966) Transaminase of branched-chain amino acids. I. Branched chain amino acid α - ketoglutarate transaminase. *J. Biochem.* 59, 160-169

- Ikeda, T., Konishi, Y. and Ichihara, A. (1976) Transaminase of branched-chain amino acids. XI. Leucine (methionine) transaminase of rat liver mitochondria. *Biochim. Biophys. Acta* 445, 622-631
- Ishikawa, E., Aikawa, T. and Matsutaka, H. (1972) The role of alanine and serine in hepatic gluconeogenesis. *J. Biochem.* 71, 1093-1095
- Jackson, A.A. and Golden, M.H.N. (1981) Deamination versus transamination. In *Nitrogen Metabolism in Man* (Waterlow, J.C. and Stephen, J.M.L., Eds.), pp. 203-213, Applied Science Publishers, London
- Jamdar, S.C. and Greengard, O. (1969) Phosphoserine phosphatase: development and hormonal regulation in rat tissues. *Arch. Biochem. Biophys.* 134, 228-232
- Jarrett, I.G., Filsell, D.H. and Ballard, F.J. (1976) Utilization of oxidizable substrates by the sheep hind-limb: Effect of starvation and exercise. *Metabolism* 25, 523-531
- Jaworek, D., Gruber, W. and Bergmeyer, H.U. (1974a) Adenosine-5-triphosphate: Determination with 3-phosphoglycerate kinase. In *Methods of Enzymatic Analysis* (Bergmeyer, H.U., Ed.) 2nd Edition, vol 4, pp. 2095-2101, Academic Press, N. York
- Jaworek, D., Gruber, W. and Bergmeyer, H.U. (1974b) Adenosine-5'-diphosphate and adenosine-5'-monophosphate. In *Methods of Enzymatic Analysis* (Bergmeyer, H.U., Ed.) 2nd Edition, vol 4, pp. 2127-2131, Academic Press, N. York
- Jefferson, L.S., Koehler, J.O. and Morgan, H.E. (1972) Effect of insulin on protein synthesis in skeletal muscle of an isolated perfused preparation of rat hemi-corpus. *Proc. Natl. Sci. U.S.A.* 69, 816-820
- Jefferson, L.S., Li, J.B. and Rannels, S.R. (1977) Regulation by insulin of amino acid release and protein turnover in the perfused rat hemi-corpus. *J. Biol. Chem.* 252, 1476-1483
- Jefferson, L.S., Wolpert, E.B., Giger, K.E. and Morgan, H.E. (1971) Regulation of protein synthesis in heart muscle. III. Effect of anoxia on protein synthesis. *J. Biol. Chem.* 246, 2171-2178
- Jordan, P.M. and Akhtar, M. (1970) The mechanism of action of serine transhydroxymethylase. *Biochem. J.* 116, 277-286

- Kadowaki, M., Noguchi, T. and Naito, H. (1984) Regulation of plasma amino acid level by perfusion of hindquarters of rats. *J. Nutr. Sci. Vitaminol.* 30, 187-198
- Kawasaki, H., Sato, T. and Kikuchi, G. (1966) A new reaction for glycine biosynthesis. *Biochem. Biophys. Res. Commun.* 23, 227-233
- Kielley, W.W. (1963) Preparation and assay of phosphorylating submitochondrial particles: Sonicated mitochondria. *Methods Enzymol.* 6, 272-277
- Kikuchi, G. (1973) The glycine cleavage system: composition, reaction mechanism, and physiological significance. *Mol. Cell. Biochem.* 1, 169-187
- Kikuchi, G., Hiraga, K. and Yoshida, T. (1980) Role of glycine-cleavage system in glycine and serine metabolism in various organs. *Biochem. Soc. Trans.* 8, 504-506
- Kirton, A.H., Bishop, W.H., Mullord, M.M. and Frozerhurst, L.F. (1978) Relationship between time of starving and time of throat-cutting and their effect on blood pressure and blood splash in lambs. *Meat Sci.* 2, 199-207
- Knudsen, J.F. and Max, S.R. (1980) Aromatization of androgens to estrogen mediates increased activity of glucose-6-phosphate dehydrogenase in rat levator ani muscle. *Endocrinology* 106, 440-443
- Komiz, D.R., Hough, A., Symonds, P. and Loki, K. (1954) The amino acid composition of actin, myosin, tropomyosin and the meromyosin. *Arch. Biochem. Biophys.* 50, 148-159
- Kondrashova, M.N. and Rodionova, (1971) Realization of the glyoxylate cycle in animal cell mitochondria. *Dokl. Akad. Nauk. SSSR*, 196, 1225-1227
- Krebs, H.A. and Hems, R. (1975) The regulation of the degradation of methionine and of one-carbon units derived from histidine. *Adv. Enz. Reg.* 14, 493-514
- Krebs, H.A. and Henseleit, K. (1932) Untersuchungen uber die harnstoffbildung im tierkorper. *Hoppe-Seyler's Z. Physiol. Chem.* 210, 33-45
- Krebs, H.A. and Lund, P. (1977) Aspects of the regulation of the metabolism of branched-chain amino acids. *Adv. Enzym. Reg.* 15, 375-394
- Kremzner, L.T. and Cote, L.J. (1968) Relationship of polyamines to nucleic acids in folic acid induced renal growth. *Fed. Proc.* 27, 839(abstr)

- Kretchmar, A.L. and Price, E.J. (1969) Use of respiration pattern analysis for study of serine metabolism *in vivo* *Metabolism* 18, 684-691
- Krieg, M. (1976) Characterization of the androgen receptor in the skeletal muscle of the rat. *Steroids* 28, 261-274
- Lamprecht, W., Stein, P., Heinz, F. and Weisser, H. (1974) In *Methods in Enzymatic Analysis* (Bergmeyer, H.U., Ed.) 2nd Edition, vol 4, pp. 1777-1783
- Landaas, S. (1977) Inhibition of branched chain amino acid degradation by ketone bodies. *Scand. J. Clin. Lab. Invest.* 37, 411-418
- Langer, B.J. Jr. (1965) The biochemical conversion of 2-hydroxy-4-methylthiobutyric acid into methionine by the rat *in vitro*. *Biochem. J.* 95, 683-687
- Lawrie, R.A. (1974) In *Meat Science* 2nd Edition, Pergamon Press, Oxford, N. York, Toronto, Sydney, Braunschweig
- Leuthardt, F. (1941) Über hippursäurebildung aus glutamine. *Hoppe-Seyler's Z. Physiol. Chem.* 270, 113-124
- Li, J.B. and Jefferson, L.S. (1977) Protein synthesis, protein degradation and lysosomal cathepsin d activity in skeletal muscle of fed and fasted rats. *Fed. Proc.* 36, 585 (Abstr)
- Lindsay, D.B. and Buttery, P.J. (1980) Metabolism of ruminant muscle. In *Protein Deposition in Animals* (Buttery, P.J. & Lindsay, D.B., Eds.), pp. 125-146 Butterworths, London.
- Lindsay, D.B. (1980) Amino acids as energy sources. *Proc. Nutr. Soc.* 39, 53-59
- Lindsay, D.B. (1978) Gluconeogenesis in ruminants. *Biochem. Soc. Trans.* 6, 1152-1156
- Lindsay, D.B., Steel, J.W. and Buttery, P.J. (1976) The output of amino acids from muscle of fed and starved sheep. *Proc. Nutr. Soc.* 36, 33A
- London, D.R. and Foley, T.H. (1965) Evidence for the release of individual amino acids from the resting human forearm. *Nature* 208, 588-589
- Long, C., King, E.J. and Sperry, W.M. (1961) In *Biochemists' Handbook*, p. 793, E. and F.N. Spon Ltd., London

- Lowry, M. and Brosnan, J.T. (1983) Serine synthesis by rat kidney; metabolic fluxes and enzyme activities. *Fed. Proc.* 42, 2236 (Abstr)
- Lowry, M., Hall, D.E. and Brosnan, J.T. (1985) Metabolism of glycine- and hydroxyproline-containing peptides by the isolated perfused rat kidney. *Biochem. J.* 229, 545-549
- Macdonald, P.C., Grodin, J.M. and Siiteri, P.K. (1971) In *Dynamics of Androgen and Estrogen Secretion*. Edinburgh University Press, Edinburgh, pp158
- Manchester, K. and Young, F. (1959) Location of ^{14}C protein from isolated rat diaphragm incubated *in vitro* with ^{14}C amino acids and with CO_2 . *Biochem. J.* 72, 136-141
- Manchester, K.L. (1965) Oxidation of amino acids by isolated rat diaphragm and the influence of insulin. *Biochim. Biophys. Acta* 100, 295-298
- Manohar, R. and Rao, N.A. (1984) Identification of active-site residues of sheep liver serine hydroxymethyl transferase. *Biochem. J.* 224, 703-707
- Marchetti, M., Tolomelli, B., Formiggini, G., Brown, C. and Barbiroli, B. (1980) Distribution of pteroylglutamates in rat liver during regeneration after partial hepatectomy. *Biochem. J.* 188, 553-556
- Martinez, J.A., Buttery, P.J. and Pearson, J.T. (1984) The mode of action of anabolic agents: The effects of testosterone on muscle protein turnover in the female rat. *Br. J. Nutr.* 52, 515-521
- Mcgilvray, D. and Morris, J.G. (1969) Utilization of L-threonine by a species of arthrobacter. *Biochem. J.* 112, 657-671
- Mehl, R.L., Paul, H.A., Shorey, W.D., Schneewind, J.H. and Beattie, E.J. (1964) Patency of the microcirculation in the traumatically amputated limb-- a comparison of common perfusates. *J. Trauma* 4, 495-505
- Meister, A. (1965) *Biochemistry of the Amino Acids*. Academic Press, N. York
- Meister, A. (1975) In *Metabolic Pathways*, 3rd Edition, vol 7 (Greenberg, D.M., Ed.), Academic Press, N. York
- Meltzer, H.L. and Springson, D.B. (1952) The synthesis of 4- ^{14}C , ^{15}N -L-Threonine and a study of its metabolism. *J. Biol. Chem.* 197, 461-474

- Miller, L.L., Bly, C.G. and Bale, W.F. (1954) Plasma and tissue proteins produced by non-hepatic rat organs as studied with lysine-C gamaglobulins produced by non-hepatic tissues. *J. Exp. Med.* 99, 133-153
- Millward, D.J., Garlick, P.J., Nnanyelugo, D.O. and Waterlow, J.C. (1976) The relative importance of muscle protein synthesis and breakdown in the regulation of muscle mass. *Biochem. J.* 156, 185-188
- Millward, D.J., Garlick, P.J., Stewart, R.J.C., Nnanyelugo, D.O. and Waterlow, J.C. (1975) Skeletal muscle growth and protein turnover. *Biochem. J.* 150, 235-243
- Millward, D.J., Nnanyelugo, D.O., James, W.P.T. and Garlick, P.J. (1974) Protein metabolism in skeletal muscle the effect of feeding and fasting on muscle RNA, free amino acids and plasma insulin concentrations. *Br. J. Nutr.* 32, 127-142
- Mimura, T., Yamado, C. and Swenseid, M.E. (1968) Influence of dietary protein levels and hydrocortisone administration on the branched-chain amino acid transaminase activity in rat tissues. *J. Nutr.* 95, 493-498
- Morton, J.L. (1980) Gluconeogenesis in sheep (1975) *Ph.D. Thesis*. University of Nottingham
- Neuberger, A. (1981) The metabolism of glycine and serine. *Coop. Biochem.* 19A, 257-303
- Nyhan, W.L. (1982) Metabolism of glycine in the normal individual and in patients with non-ketotic hyperglycinaemia. *J. Inher. Metab. Dis.* 5, 105-110
- Nyhan, W.L. (1983) Non-ketotic hyperglycinemia. In *The Metabolic Basis of Inherited Disease*. (Stanbury, J., Wyngaarden, J. and Frederickson, D., Eds.) 5th Edition, pp. 518-527, McGraw-Hill, N. York
- O'Brien, W.E. (1978) Inhibition of glycine synthase by branched chain α -keto acids. *Arch. Biochem. Biophys.* 189, 291-297
- O'Donovan, M.J., Rowlerson, A. and Taylor, A. (1975) The perfused isolated human limb: An assessment of its viability. *J. Physiol. (London)* 256, 27P-28
- Odessey, R., Khairallah, E.A., Goldberg, A.C. (1974) Origin and possible significance of alanine production by skeletal muscle. *J. Biol. Chem.* 249, 7623-7629

- Olsen, R.F., Wangness, P.J., Martin, R.J. and Ghagan, J.H. (1977) Effect of zeranol on blood metabolites and hormones in wether lambs. *J. Anim. Sci.* 45, 1392-1396
- Owen, E.E. and Robinson, R.R. (1963) Amino acid extraction and ammonia metabolism by the human kidney during prolonged administration of ammonium chloride. *J. Clin. Invest.* 42, 263-276
- Palekar, A.G., Tate, S.S. and Meister, A. (1973) Rat liver aminomalonnate decarboxylase. *J. Biol. Chem.* 248, 1158-1167
- Patridge, W.M., Duducgian-Vartavarian, L., Casanells-Ertl, D., Jones, M.R. and Kopple, J.D. (1982) Arginine metabolism and urea synthesis in cultured rat skeletal muscle cells. *Am. J. Physiol.* 242, E87-92
- Pawlak, M. and Pion, R. (1968) Influence de la supplementation des protein de ble par des doses croissants de lysine sur la teneur en acides amines libres du sang et du muscle du rat en croissance. *Biochim. Biophys.* 8, 517-530
- Pennington, R.J. (1952) The metabolism of short-chain fatty acids in the sheep. I. Fatty acid utilization and ketone body production by rumen epithelium and other tissues. *Biochem. J.* 51, 251-258
- Pitts, R.F. and Pilkington, L.A. (1966) The relationship between plasma concentration of glutamine and glycine and utilization of their nitrogen as sources of urinary ammonia. *J. Clin. Invest.* 45, 86-93
- Pitts, R.F., Damian, A.C. and Macleod, M.B. (1970) Synthesis of serine by rat kidney *in vivo* and *in vitro*. *Am. J. Physiol.* 219, 584-589
- Pitts, R.F. and MacLeod, M.B. (1972) Synthesis of serine by the dog kidney *in vivo*. *Am. J. Physiol.* 222, 394-398
- Powers, M.L. and Florini, J.R. (1975) A direct effect of testosterone on muscle cells in tissue culture. *Endocrinology* 97, 1043-1047
- Pozefsky, T., Felig, P., Tobin, T.D., Soeldner, J.S. and Cahill, G.F.Jr. (1969) Amino acid balance across tissues of the forearm in postabsorptive man. Effects of insulin at two dose levels. *J. Clin. Invest.* 48, 2273-2282
- Pozefsky, T., Tancredi, R.G., Moxley, R.T., Dupre, J. and Tobin, J.D. (1976) Effects of brief starvation on muscle amino acid metabolism in nonobese man. *J. Clin. Invest.* 57, 444-449

- Preedy, V.R., Pain, V.M. and Garlick, P.J. (1984) The metabolic state of muscle in the isolated perfused rat hemicorpus in relation to rates of protein synthesis. *Biochem. J.* 218, 429-440
- Pycock, C.J. and Kerwin, R.W. (1981) The status of glycine as a supraspinal neurotransmitter. *Life Sci.* 28, 2679-2686
- Radcliffe, B.C. and Egan, A.R. (1974) A survey of methionine adenosyltransferase and cystathione γ -lyase activities in ruminant tissues. *Aust. J. Biol. Sci.* 26, 653-659
- Ramesh, K.S. and Rao, N.A. (1980) Purification and physicochemical, kinetic and immunological properties of allosteric serine hydroxymethyltransferase from monkey liver. *Biochem. J.* 187, 623-636
- Ramesh, K.S. And Rao, N.A. (1978) Regulation of monkey liver serine hydroxymethyltransferase by nicotinamide nucleotide. *Biochem. J.* 174, 1055-1058
- Rannels, D.E., Kuo, R. and Morgan, H.E. (1975) Effect of insulin on protein turnover in heart muscles. *J. Biol. Chem.* 250, 1694-1701
- Ratner, S., Rittenberg, D., Keston, A.S. and Schoenheimer, R. (1940) Studies in protein metabolism. XIV. The chemical interaction of dietary glycine and body protein in rats. *J. Biol. Chem.* 134, 665-669
- Reeds, P.J. (1981) Creatine and creatine metabolism. In *Metabolism in Man* (Waterlow, J.C. and Stephen, J.M.L., Eds.), pp. 263-268, Applied Science Publishers, London, U.K.
- Reimer, F., Löffler, G., Hennig, G. and Wieland, D.H. (1975) The isolated perfused rat hind quarter. *Hoppe-Seyler's Z. Physiol.* 356, 1055-1066
- Remesy, C., Fafournoux, P. and Demigne, C. (1983) Control of hepatic utilization of serine, glycine and threonine in fed and starved rats. *J. Nutr.* 113, 28-39
- Rennie, M.J. and Holloszy, J.O. (1977) Inhibition of glucose uptake and glucogenolysis by availability of oleate in well-oxygenated perfused skeletal muscle. *Biochem. J.* 168, 161-170
- Riess, J.G. and LeBlank, M. (1982) Solubility and transport phenomena in perfluorochemicals relevant to blood substitution and other biomedical applications. *Pure Appl. Chem.* 54, 2383-2406

- Rixon, R.H. and Stephenson, J.A.F. (1956) The water and electrolyte metabolism of rat diaphragm *in vitro*. *Can. J. Biochem. Physiol.* 34, 1069-1083
- Robert, J.J., Bier, D.M., Zhao, X.H., Matthews, D.E. and Young, V.R. (1982) Glucose and insulin effects on *de novo* amino acid synthesis in young men: Studies with stable isotope labeled alanine, glycine, leucine and lysine. *Metabolism* 31, 1210-1218
- Robins, R.J. and Davies, D.D. (1985) Stimulation of glutathione degradation by amino acids: Lack of stereospecificity. *Comp. Biochem. Physiol.* 80B, 831-837
- Robins, S.P. (1982) In *Collagen in Health and Disease* (Weiss, J.B. and Jayson, M.I.V., Eds.), pp. 160-178, Churchill-Livingstone, Edinburgh, London, Melbourne and N. York
- Roehrig, K.L. and Allred, J.B. (1974) Direct enzymatic procedure for the determination of liver glycogen. *Anal. Biochem.* 58, 414-421
- Rookledge, K.A. (1971) Comparison of some metabolic parameters in the perfused and the incubated rat diaphragm muscle with diaphragm muscle *in vivo*. *Biochem. J.* 125, 93-96
- Ross, B.D. (1972) In *Perfusion Techniques in Biochemistry*. Clarendon Press, Oxford
- Ross, B.D., Hems, R. and Krebs, H.A. (1967) The rate of gluconeogenesis from various precursors in the perfused rat liver. *Biochem. J.* 102, 942-951
- Rovinett, C., Bovina, C., Tolomelli, B. and Marchetti, M. (1972) Effect of testosterone on the metabolism of folate coenzymes in the rat. *Biochem. J.* 126, 291-294
- Rowell, K.V., Al-Naama, L.M.R. and Bennett, P. (1982a) The subcellular distribution of rat liver serine-pyruvate aminotransferase. *Biochem. J.* 202, 483-490
- Rowell, E.V., Al-Naam, M.M. and Rowell, K.V. (1982b) Glycine metabolism in rat kidney cortex slices. *Biochem. J.* 204, 313-321
- Rowell, E.V., Carnie, J.A. and Snell, K. (1969) An assay for L-alanine-glyoxylate aminotransferase. *Biochem. J.* 112, 7P

- Rowell, E.V., Snell, K., Carnie, J.A. and Rowell, K.V. (1972) The subcellular distribution of rat liver L-alanine-glyoxylate aminotransferase in relation to a pathway for glucose formation involving glyoxylate. *Biochem. J.* 127, 155-165
- Rowell, K.V., Ali, T.A.J. and Rowell, E.V. (1975) A difference in the incorporation of ^{14}C into hippurate glycine from DL-(2- ^{14}C)-glutamate and DL-(5- ^{14}C)-glutamate in guinea pigs. *Biochem. J.* 152, 357-363
- Ruderman, N.B. (1975) Muscle amino acid metabolism and gluconeogenesis. *Ann. Rev. Med.* 26, 245-257
- Ruderman, N.B. and Berger, M. (1974) The formation of glutamine and alanine in skeletal muscle. *J. Biol. Chem.* 249, 5500-5506
- Ruderman, N.B. and Herrera, M.G. (1968) Glucose regulation of hepatic gluconeogenesis. *Am. J. Physiol.* 214, 1346-1351
- Ruderman, N.B. and Lund, P. (1972) Amino acid metabolism in skeletal muscle-- regulation of glutamine and alanine release in the perfused rat hindquarter. *Israel. J. Med. Sci.* 8, 295-302
- Ruderman, N.B., Houghton, C.R.S. and Hems, R. (1971) Evaluation of isolated rat hindquarter for the study of muscle metabolism. *Biochem. J.* 124, 639-651
- Ruderman, N.B., Kemmer, F.W., Goodman, M.N. and Berger, M. (1980) Oxygen consumption in perfused skeletal muscle. *Biochem. J.* 190, 57-64
- Sallach, H.J., Sanborn, T.A. and Bruin, W.J. (1972) Dietary and hormonal regulation of hepatic biosynthetic and catabolic enzymes of serine metabolism in rats. *Endocrinology* 91, 1054-1063
- Sanborn, T.A., Kowle, R.L. and Sallach, H.J. (1975) Regulation of enzymes of serine and one-carbon metabolism by testosterone in rat prostate, liver and kidney. *Endocrinology* 97, 1000-1007
- Sandoval, I.V. and Sols, A. (1974) Gluconeogenesis from serine by the serine-dehydrogenase-dependent pathway in rat liver. *Eur. J. Biochem.* 43, 609-619
- Sapir, D.G. and Walser, M. (1977) Nitrogen sparing induced early in starvation by infusion of keto-analogues of branched-chain amino acids. *Metabolism* 26, 301-308

- Sardesai, V.M. and Provido, H.S. (1970) The determination of glycine in biological fluids. *Clin. Chem. Acta* 29, 67-71
- Sato, T., Kochi, H., Motokawa, Y., Kawasaki, H. and Kikuchi, G. (1969) Glycine metabolism by rat liver mitochondria. I. Synthesis of two molecules of glycine from one molecule each of serine, biocarbonate and ammonia. *J. Biochem.* 65, 63-70
- Schirch, L. (1982) Serine hydroxymethyltransferase. *Adv. Enzymol.* 53, 83-112
- Schirch, L. and Gross, T. (1968) Serine transhydroxymethylase. *J. Biol. Chem.* 243, 5651-5655
- Schirch, L., Mozzarelli, A., Ottonello, S. and Rossi, G.L. (1981) Microspectrophotometric measurements on single crystals of mitochondrial serine hydroxymethyltransferase. *J. Biol. Chem.* 256, 3776-3780
- Schmitz, H., Van Potter, R., Hurlbert, R.B. and White, D.M. (1954) Alternative pathways of glucose metabolism. II. Nucleotides from the acid-soluble fraction of normal and tumour tissues and studies on nucleic acid synthesis in tumours. *Cancer Res.* 14, 66-74
- Schwerin, P., Bessman, S.P. and Waelsh, H. (1950) The uptake of glutamic acid and glutamine by brain and other tissues of the rat and mouse. *J. Biol. Chem.* 184, 37-44
- Sedlak, J. and Lindsay, R.H. (1968) Estimation of total, protein-bound, and nonprotein sulfhydryl groups in tissue with Ellman's reagent. *Anal. Biochem.* 25, 192-205
- Seitz, H.J., Muller, M.J., Krone, W. and Tarnowski, W. (1977) Rapid conversion by insulin of hepatic intermediary metabolism from glucose production to glucose utilization in the liver of alloxan-diabetic rats. *Diabetes* 26, 1159-1174
- Sheehan, T.G. and Tully, E.R. (1983) Purine biosynthesis *de novo* in rat skeletal muscle. *Biochem. J.* 216, 605-610
- Shemin, D. (1949) Some aspects of the biosynthesis of amino acids. *Cold Spring Harbor Symp. Quant. Biol.* 14, 161-167
- Shepperson, N.P.G. (1983) Control of amino acid metabolism in sheep muscle. *Ph.D Thesis.* University of Nottingham

- Shields, R. (1978) Pleiotypic effects of hormones. *Nature* 276, 440-441
- Sinnott-Smith, P.A., Palmer, C.A. and Buttery, P.J. (1983) Androgen and oestrogen binding in sheep skeletal muscle cytosol after treatment with trenbolone acetate. *Proceedings of the 4th EAAP Symposium on Protein Metabolism and Nutrition*, pp. 77-80, Clermont-Ferrand, France
- Skutul, K. (1908) Ueber durchstromungsapparate pfluegers. *Arch. Gesamte Physiol. Menschen Tiere* 123, 249 (Cited: *Fed. Proc.* 36, 159-160, 1977)
- Smith, R.J., Larson, S., Stred, S.E. and Durschlag, R.P. (1984) Regulation of glutamine synthetase and glutaminase activities in cultured skeletal muscle cells. *J. Cell. Physiol.* 129, 197-203
- Snell, K. (1975) Mitochondrial-cytosolic interrelationships involved in gluconeogenesis from serine in rat liver. *FEBS Lett.* 55, 202-205
- Snell, K. (1980a) Liver enzymes of serine metabolism during neonatal development of the rat. *Biochem. J.* 190, 451-455
- Snell, K. (1980b) Muscle alanine synthesis and hepatic gluconeogenesis. *Biochem. Soc. Trans.* 8, 205-213
- Snell, K. and Duff, D.A. (1980c) Alanine and glutamine formation by muscle. *Biochem. Soc. Trans.* 8, 501-504
- Snell, K. and Duff, D.A. (1985) Branched-chain amino acid metabolism mitochondrial-cytosolic interrelationship. *Biochem. J.* 225, 737-743
- Speisky, H., Mac-Donald, A., Giles, G., Orrego, H. and Israel, Y. (1985) Increased loss and decreased synthesis of hepatic glutathione after acute ethanol administration. Turnover studies. *Biochem. J.* 225, 565-572
- Squires, E.J., Hall, D.E. and Brosnan, J.T. (1976) Arteriovenous differences for amino acids and lactate across kidneys of normal and acidotic rats. *Biochem. J.* 160, 125-128
- Stein, W.H. and Moore, S. (1954) The free amino acids of human blood plasma. *J. Biol. Chem.* 211, 915-926
- Strohfeldt, P., Kette, H., Obermaier, U and Weinges, K.F. (1975a) Immediate effects of buformin on muscle metabolism. *Horm. Metab. Res.* 7, 355

- Strohfeldt, P., Kette, H., Obermaier, U. and Weinges, K.F. (1975b) Effect of buformin on the metabolism of the isolated hemoglobin-free perfused hind-limb of normal rat. *Diabetologia* 11, 187-189
- Strohfeldt, P., Kettl, H. and Weinges, K.E. (1974) Perfusion of the isolated rat hind-limb with a synthetic medium. *Hora. Metab. Res.* 6, 167-168
- Stryer, L. (1981) In *Biochemistry*. W.H. Freeman and Company
- Sugano, T., Suda, K., Shimada, M. and Oshino, N. (1978) Biochemical and ultrastructural evaluation of isolated rat liver systems perfused with a hemoglobin-free medium. *J. Biochem.* 83, 995-1007
- Swierczynski, J. and Makarewicz, W. (1978) Glutaminase activity in rat skeletal muscle mitochondria. *Experientia* 34, 165-166
- Tait, G.H. (1978) In *Heme and Hemoproteins* (Matteis, F. De and Aldridge, W.N., Eds.), pp. 1-48, Springer, Heidelberg
- Takahashi, J. (1983) Effect of intra-pregastric administration of nitrite on erythrocyte GSH and GSSG content of male golden hamster. (*Mesocricetus auratus*). *Comp. Biochem. Physiol.* 76B, 1-4
- Tao, R.C., Asplund, J.M. and Kappel, L.C. (1974) Response of nitrogen metabolism, plasma amino acids and insulin levels to various levels of methionine infusion in sheep. *J. Nutr.* 104, 1646-1656
- Taylor, R.T. and Jenkins, W.T. (1966) Leucine aminotransferase. II. Purification and characterization. *J. Biol. Chem.* 241, 4396-4405
- Taylor, R.T. and Weissbach, H. (1965) Radioactive assay for serine transhydroxymethylase. *Anal. Biochem.* 13, 80-84
- Teanne, B.L. and Goldberg, A.L. (1976) Effect of food deprivation on protein synthesis and degradation in rat skeletal muscle. *Am. J. Physiol.* 231, 441-448
- Teteni, E. and Annison, E.F. (1983) Catabolism of branched chain acids by ruminant muscle. *Proc. Nutr. Soc.* 42, 92A
- Teteni, E., Annison, E.F. and Lindsay, D.B. (1983) Valine catabolism in sheep hindlimb muscle. *4th International Symposium on Protein Metabolism and Nutrition (EAAP)*, vol2, pp. 89-92, Clermont-Ferrand, France.

- Thomas, P.A. (1973) Monitoring. In *Isolated Organ Perfusion* (Ritchie, H.D. and Hardcastle, J.D., Eds.), pp. 60-67, Crosby Lockwood Staples, London
- Thorndike, J., Pelliniemi, T.T. and Beck, W.S. (1979) Serine hydroxymethyltransferase (EC 2.1.2.1) activity and serine incorporation in leukocytes. *Cancer Res.* 39, 3435-3440
- Tomas, F.M., Munro, H.N. and Young, V.R. (1979) Effect of glucocorticoid administration on the rate of muscle protein breakdown *in vivo* in rats, as measured by urinary excretion of N'-methylhistidine. *Biochem. J.* 178, 139-146
- Triner, L., Verosky, M., Habif, D.V. and Nahas, G.G. (1970) Perfusion of isolated liver with fluorocarbon emulsions. *Fed. Proc.* 29, 1778-1781
- Ullrich, V. and Dielh, H. (1971) Uncoupling of monooxygenation and electron transport by fluorocarbons in liver microsomes. *Europ. J. Biochem.* 20, 509-512
- Umbarger, H.E. (1981) Regulation of amino acid metabolism. In *Comprehensive Biochemistry* 19A, pp. 1-49 (Neuberger, A. and Van Deenen, L.L.M., Eds.), Elsevier North-Holland Inc., N. York
- Van slyke, D.D., Dillon, R.T., Macfadyen, D.A. and Hamilton, P. (1941) Gasometric determination of carboxyl groups in free amino acids. *J. Biol. Chem.* 141, 627-669
- Vernon, B.G., Buttery, P.J. (1978) The effect of trenbolone acetate with time on the various responses of protein synthesis of the rat. *Br. J Nutr.* 40, 563-572
- Vernon, B.G. (1977) The effect of trenbolone acetate on protein turnover. *Ph.D Thesis.* University of Nottingham
- Walser, M., Lund, P., Ruderman, N.B. and Coulter, A.W. (1973) Synthesis of essential amino acids from their α -keto analogues by perfused rat liver and muscle. *J. Clin. Invest.* 52, 2865-2877
- Walsh, D.A. and Sallach, H.J. (1966) Comparative studies on the pathways for serine biosynthesis in animal tissues. *J. Biol. Chem.* 241, 4068-4076
- Wannemacher, R.W.Jr. (1975) Protein Metabolism. In *Total Parental Nutrition Premises and Promises* (Ghadimi, H., Ed.), pp. 85-153, J. Wiley and Sons Inc., N. York

- Wannemacher, R.W.Jr., Wannemacher, C.F. and Yatvin, M.B. (1971) Amino acid regulation of synthesis of ribonucleic acid and protein in the liver of rats. *Biochem. J.* 124, 385-392
- Ward, L.C., and Buttery, P.J. (1979) The kinetics of myofibrillar protein breakdown in perfused skeletal muscle. *Biochim. Biophys. Acta* 587, 415-423
- Ward, L.C. (1976) Muscle Protein Metabolism. *Ph.D Thesis.* University of Nottingham
- Ward, L.C., Boorman, K.N. and Buttery, P.J. (1982) Amino acid supply and protein metabolism in isolated perfused rat skeletal muscle. *Horm. Metab. Res.* 14, 30-33
- Waterlow, J.C. and Stephen, J.M.L. (1968) The effect of low protein diets on the turnover rates of serum, liver and muscle proteins in the rat, measured by continuous infusion of L-¹⁴C lysine. *Clin. Sci.* 35, 287-305
- Waterlow, J.C., Garlick, P.J. and Millward, D.J. (1978) In *Protein Turnover in Mammalian Tissues and in the Whole Body.* pp. 626-696. Amsterdam, Elsevier-North Holland
- White, A., Handler, P. and Smith, E.L. (1964) *Principles of Biochemistry.* McGraw-Hill Book Company, N. York
- Williamson, D.H., Lund, P. and Krebs, H.A. (1967) The redox state of free nicotinamide adenine dinucleotide in the cytoplasm and mitochondria of rat liver. *Biochem. J.* 103, 514-527
- Wijayasinghe, M.S., Thompson, J.R. and Milligan, L.P. (1984) The metabolic fate of leucine in muscle and adipose tissue of sheep. *Can. J. Anim. Sci.* 64 (supplement) 283-284
- Wolff, J.E. and Bergman, E.N. (1972a) Gluconeogenesis from plasma amino acids in fed sheep. *Am. J. Physiol.* 223, 455-460
- Wolff, J.F. and Bergman, E.N. (1972b) Metabolism and interconversion of five amino acids by tissues of the sheep. *Am. J. Physiol.* 223, 447-454
- Wynngaarden, J.B. and Kelly, W.N. (1982) Gout. In *The Metabolic Basis of Inherited disease* (Stanbury, J.B., Wynngaarden, J.B., Fredrickson, D.S., Goldstein, J.L. and Brown, M.S., Eds.), 5th edition, pp. 1043-1114, McGraw-Hill, N.York

- Xue, G-P. and Snoswell, A.M. (1985) Comparative studies on the methionine synthesis in sheep and rat tissues. *Comp. Biochem. Physiol.* 80B, 489-494
- Yamamoto, H., Aikawa, T., Matsutaka, H., Okuda, T. and Ishikawa, E. (1974) Interorgan relationships of amino acid metabolism in fed rats. *Am. J. Physiol.* 226, 1428-1433
- Yedgar, S., Carew, T.E., Pittman, R.C., Beltz, W.F. and Steinberg, D. (1983) Tissue sites of catabolism of albumin in rabbits. *Am. J. Physiol.* 244, E101-107
- Yoe, J.H. and Reid, L.C. (1941) Determination of formaldehyde with 5,5-dimethylcyclohexane-1,3. *Ind. Eng. Chem.* 13, 238-240
- Yoshida, T. and Kikuchi, G. (1970) Major pathways of glycine and serine catabolism in rat liver. *Arch. Biochem. Biophys.* 139, 380-392
- Yoshida, T. and Kikuchi, G. (1973) Major pathways of serine and glycine metabolism in various organs of the rat and cock. *J. Biochem.* 73, 1013-1022
- Yu, Y.M., Yang, R.D., Matthews, D.E., Wen, Z.M., Burke, J.F., Bier, D.M. and Young, V.R. (1985) Quantitative aspects of glycine and alanine nitrogen metabolism in postabsorptive young men: Effects of level of nitrogen and dispensable amino acid intake. *J. Nutr.* 115, 399-410