

Saunders, Gabrielle H. (1989) Determinants of objective and subjective auditory disability in patients with normal hearing. PhD thesis, University of Nottingham.

Access from the University of Nottingham repository:

<http://eprints.nottingham.ac.uk/12959/1/235439.pdf>

Copyright and reuse:

The Nottingham ePrints service makes this work by researchers of the University of Nottingham available open access under the following conditions.

This article is made available under the University of Nottingham End User licence and may be reused according to the conditions of the licence. For more details see:
http://eprints.nottingham.ac.uk/end_user_agreement.pdf

A note on versions:

The version presented here may differ from the published version or from the version of record. If you wish to cite this item you are advised to consult the publisher's version. Please see the repository url above for details on accessing the published version and note that access may require a subscription.

For more information, please contact eprints@nottingham.ac.uk

**Determinants of Objective and Subjective Auditory
Disability in Patients with Normal Hearing**

by

Gabrielle H. Saunders BSc.

Thesis submitted to the University of Nottingham
for the degree Doctor of Philosophy, May, 1989

Contents		i
Acknowledgements		xii
Abstract		xiv
CHAPTER 1		1
1.1	Introduction	2
1.2	Literature Review	3
1.2.1	Research Directly Related to OAD	3
1.2.1.1	Psychoacoustic Studies	4
1.2.1.2	Central/Cognitive Studies	7
1.2.1.3	Multifactorial Studies	9
1.2.2	Research Hypothetically Related to OAD	10
1.2.2.1	Psychoacoustic Research	10
	(a) Frequency Resolution	10
	(b) Excessively Strict Clinical Definition of Normality	11
1.2.2.2	Central/Cognitive Research	12
	(a) Lipreading Ability	12
	(b) Linguistic Abilities	12
	(c) Central/Linguistic Deficits due to Childhood Otitis Media	13
1.2.2.3	Personality-related research	14
	(a) Personality Factors Relating to General Health Beliefs	14
	(b) Personality Factors Relating directly to Hearing Problems	16
	(c) Personality Altering Judgement of Hearing	17
1.2.3	Summary	18

CHAPTER 2		19
2.1	Introduction	20
2.2	Factors Investigated	20
2.2.1	General Factors	20
	(a) Subjective Disability	20
	(b) Performance Disability	21
2.2.2	Minor Auditory Pathology	22
	(a) Poor Frequency Resolution	22
	(b) 'Incorrect' Definition of Normality	23
	(c) Minor Auditory Damage due to Noise Exposure	24
2.2.3	Central/Cognitive Processing Deficits	25
	(a) Poor Lipreading Skills	25
	(b) Poor Linguistic Ability	25
	(c) Central Auditory Deficit	26
2.2.4	Personality-Related Factors	26
	(a) Personality and Concern about Health/Hearing	26
	(b) Personality Altering Perception of own Hearing Ability	27
2.3	Methods	27
2.3.1	Subjects	27
2.3.2	General Procedure	28
2.3.3	Test Battery	30
2.3.3.1	General Tests	30
	(a) Special OAD Interview	30
	(b) IHR Hearing Questionnaire	31
	(c) Performance Test - the PFFIN Test	31
2.3.3.2	Psychoacoustic Tests	33
	(a) Pure Tone Audiogram	33
	(b) Tympanogram	33
	(c) Frequency Resolution (PTC)	34
	(d) Comparison of Forced-Choice and Clinically determined Thresholds	35
	(e) Noise Immission Rating (NIR)	36

2.3.3.3	Central/Cognitive Tests	36
	(a) BKB Audiovisual Test	36
	(b) Sentence Completion Test	37
2.3.3.4	Personality-related Tests: Crown-Crisp Questionnaire	39
2.4	Results	39
2.4.1	OAD Status	40
2.4.2	Psychoacoustic Factors	40
	(a) Auditory Thresholds	40
	(b) Tympanometry	42
	(c) Frequency Resolution	42
2.4.3	Performance Tests	42
	(a) PFFIN Test	42
	(b) BKBAV Test	43
2.4.4	Central/Cognitive Test: Sentence Completion Test	44
2.4.5	Personality-Related Factors: Crown-Crisp Questionnaire	45
2.4.6	Otological History	45
2.4.7	Reported Disability and Handicap: IHR Hearing Questionnaire	46
2.5	Discussion	46
2.5.1	Determinants of OAD Status	46
2.5.2	Psychoacoustic Factors	47
	(a) Pure Tone Thresholds	47
	(b) Frequency Resolution	47
2.5.3	Performance Factors	48
2.5.4	Personality-Related Factors	50
2.5.5	Otological History	50
2.6	Summary and Conclusions	51
2.7	Implications for Stage II	52

CHAPTER 3		53
3.1	Introduction	54
3.2	Determination of the Stage II Test Battery	55
3.2.1	Psychoacoustic Measures	55
	(a) Frequency Resolution	55
	(b) Temporal Resolution	57
	(c) Binaural Hearing	59
	(d) Evoked Otoacoustic Emissions (EOEs)	60
	(e) Diminished Pure Tone Sensitivity at 'Unconventional' Frequencies	61
3.2.2	Central/Cognitive Factors	61
	(a) Lipreading Test	61
	(b) Linguistic Processing	62
	(c) Dichotic Listening Test	65
3.2.3	Performance Measures	66
	(a) PFFIN Test	66
	(b) Four Alternative Auditory Feature Test (FAAF) of Speech-in-Quiet	69
3.2.4	Tests Repeated from Stage I	69
3.3	Methods	70
3.3.1	Setting up of the OAD Clinic	70
3.3.2	Subjects	71
3.3.3	General Procedure	72
3.3.4	Test Battery	74
3.3.4.1	General Tests	74
	(a) + (b) OAD Interview and Hearing Questionnaire	74
	(c) Adaptive PFFIN Test - Self-Assessed and Performance Conditions	74
	(d) The FAAF Test - Band-Filter Version	81
3.3.4.2	Psychoacoustic Tests	82
	(a) Pure Tone Audiogram	82
	(b) Frequency Resolution	82
	(c) Temporal Resolution	83
	(d) Binaural Masking Level Difference	83
	(e) Measurement of EOEs	88

3.3.4.3	Central/Cognitive Tests	90
	(a) Audiovisual Test	90
	(b) Dichotic Listening Test	91
	(c) Sentence Monitoring Test	93
3.3.4.4	Tests of Personality-Related Factors	96
	(a) Crown-Crisp Questionnaire	96
	(b) Mis-judgement of Hearing Ability	96
3.4	Results	97
3.4.1	Patient Profile	97
3.4.2	Univariate Analyses	102
3.4.2.1	OAD Status	103
3.4.2.2	Psychoacoustic Factors	104
	(a) Auditory Thresholds	104
	(b) Psychoacoustic Tests	104
	(c) Evoked Acoustic Emissions	107
3.4.2.3	Performance Tests	109
	(a) PFFIN	109
	(b) Band-Filtered FAAF Test in Quiet	113
	(c) Audiovisual Test	114
3.4.2.4	Central/Cognitive Factors	114
	(a) Dichotic Listening Test	114
	(b) Sentence Monitoring Test	115
	(c) Cognition-Related Factors from the Interview	116
3.4.2.5	Personality-Related Factors	117
	(a) Crown-Crisp Questionnaire	117
	(b) Health Beliefs	117
3.4.2.6	Factors Associated with a History of Ear Disorder	117
3.4.2.7	Reported Auditory Disability and Handicap	118
3.4.3	Multivariate Analyses	118
3.4.3.1	Modelling using the Whole OAD Group	119
3.4.3.1.1	Accounting for OAD Status	119
3.4.3.1.2	Modelling of the PSRTN and PS-DISN	128

3.4.3.2	Modelling using Possible Sub-groups	130
3.4.3.2.1	Accounting for OAD Status in Sub-groups	131
3.4.3.2.2	Modelling of the PSRTN and PS-DISN within the OAD sub-groups	136
3.5	Discussion	140
3.5.1	Discussion of Univariate Analyses	140
3.5.1.1	Determinants of OAD Status	140
3.5.1.2	Psychoacoustic Factors	140
	(a) Pure Tone Sensitivity	140
	(b) Masked Thresholds	142
	(c) Frequency Resolution	143
	(d) Temporal Resolution	145
	(e) Binaural Masking Level Difference	145
	(f) Evoked Otoacoustic Emissions	146
3.5.1.3	Performance Tests	147
	(a) PFFIN	147
	(b) FAAF Test	151
	(c) Audiovisual Test	152
3.5.1.4	Central/Cognitive Tests	152
	(a) Dichotic Listening Test	153
	(b) Sentence Monitoring Test	154
	(c) Cognition-related Factors from the Interview	154
3.5.1.5	Personality-Related Factors: Crown-Crisp Questionnaire and Health Beliefs	155
3.5.1.6	Factors Associated with an Otological History	156
3.5.1.7	Reported Auditory Disability and Handicap	156
3.5.1.8	Summary and Conclusions	157
3.5.2	Discussion of Multivariate Analyses	158
3.5.2.1	Accounting for OAD Status	159
3.5.2.2	Modelling of Abilities	162
3.5.2.2.1	Modelling of the PSRTN	163
	(a) Degree Variance Explained by Models	163
	(b) Variables in the Models of the PSRTN	163

3.5.2.2.2	Modelling of the PS-Discrepancy	165
	(a) Degree Variance Explained by Models	165
	(b) Variables in Models of the PS-DISN	166
3.5.2.3	Summary and Conclusions	168
3.6	General Summary and Conclusions	169
CHAPTER 4		170
4.1	Introduction	171
4.2	Evaluations	172
4.2.1	Consultants' Evaluation	172
4.2.1.1	Subjects	172
4.2.1.2	Procedure	172
4.2.1.3	Results	173
	(a) General Communication with IHR	173
	(b) Consultants' Comments on Patients' Reports	174
	(c) General Comments	174
4.2.1.4	Discussion and Conclusions	175
4.2.2	Patients' Evaluation	177
4.2.2.1	Subjects and Procedure	177
4.2.2.2	Results	177
	(a) Test Battery	177
	(b) Results and Advice	178
4.2.2.3	Discussion and Conclusions	179
4.3	OAD Course for Consultants	180
4.4	Clinical Test Package	181
4.4.1	Introduction	181
4.4.2	Theoretical Considerations behind the Clinical Package	182
4.4.3	Tests in the Clinical Package	183
4.4.4	Using the Clinical Package	184

4.4.4.1	Contingency Pathways - Set A	186
4.4.4.2	Contingency Pathways - Set B	188
4.4.4.3	Theoretical Comparison of Sets A and B	190
4.4.5	Contingent versus Battery Testing	193
4.4.6	Future Research	193
CHAPTER 5		195
5.1	Introduction	196
5.2	Literature Review	196
5.3	Method	199
5.4	Results	200
5.4.1	Homogeneity of the OAD and Random-Control Sub-samples	201
	(a) Comparison of OAD and Random-Control sub-samples with the Remainder of their Sample	201
	(b) Comparison of the OAD Sub-Sample and the Random-Control Sub-Sample	202
5.4.2	Comparison of Patient-Controls with the OAD and Random-Control Sub-Samples	204
	(a) Patient-Controls vs Random-Controls	204
	(b) Patient-Controls vs OAD Sub-Sample	206
5.5	Discussion	207
5.5.1	Homogeneity of the OAD and Random-Control Populations	207
5.5.2	Comparisons of the OAD and Random-control Sub-samples with the Patient-controls	208
5.6	Summary and Conclusions	211

CHAPTER 6		212
6.1	Introduction	213
6.2	Relations Between Self-rated Auditory Disability/Handicap and Psychoacoustic, Cognitive/Central and Personality-Related Variables	214
6.2.1	Literature Review	214
6.2.2	Expected Relationships	219
6.2.2.1	Psychoacoustic Correlates	219
6.2.2.2	Central/Cognitive Correlates	221
6.2.2.3	Personality-related Correlates	222
6.2.3	Method	223
6.2.4	Results and Discussion	224
6.2.4.1.1	Results: Psychoacoustic Correlates of Self-rated Disability and Handicap	224
6.2.4.1.2	Discussion: Psychoacoustic Correlates of Self-rated Disability and Handicap	227
6.2.4.2.1	Results: Central/Cognitive Correlates of Self-rated Disability and handicap	231
6.2.4.2.2	Discussion: Central/Cognitive Correlates of Self-rated Disability and handicap	233
6.2.4.3.1	Results: Demographic and Personality-Related Correlates of Self-rated Disability and Handicap	235
6.2.4.3.2	Discussion: Demographic and Personality-Related Correlates of Self-rated Disability and Handicap	236
6.2.5	General Summary and Conclusions	238
6.3	Relations between Performance Ability and Psychoacoustic, Cognitive and Personality-related Variables	240
6.3.1	Literature Review	240

6.3.1.1	Studies of Hearing-Impaired Individuals	241
6.3.1.2	Studies of Normally-Hearing Individuals	243
6.3.1.3	Central/Cognitive, Personality-Related and Demographic Studies	244
6.3.2	Expected Relationships	246
6.3.2.1	Psychoacoustic Correlates	246
6.3.2.2	Central/Cognitive Correlates	247
6.3.2.3	Demographic and Personality-Related Correlates	248
6.3.3	Method	248
6.3.4	Results	249
6.3.4.1.1	Results: Psychoacoustic Correlates of Performance Measures	249
6.3.4.1.2	Discussion: Psychoacoustic Correlates of Performance Measures	252
6.3.4.2.1	Results: Central/Cognitive Correlates of Performance Measures	258
6.3.4.2.1	Discussion: Central/Cognitive Correlates of Performance Measures	259
6.3.4.3.1	Results: Demographic and Personality- Related Correlates of Performance Measures	260
6.3.4.3.2	Discussion: Demographic and Personality- Related Correlates of Performance Measures	262
6.3.5	General Summary and Conclusions	264
CHAPTER 7		265
7.1	Final Summary and Conclusions	266

Appendices		268
Appendix 2.1	Final Form of OAD Interview	269
Appendix 3.1	Information sent to Consultants about the Special Investigative Clinic	279
Appendix 3.2	Typical Clinical Report about an OAD Patient	285
Appendix 3.3	Clinical Report of a non-OAD Patient	287
Appendix 3.4	Instructions for Stage II Tests	289
Appendix 3.5	Preparation of the PFFIN Test	301
Appendix 3.6	Sentences for the Lipreading Test	308
Appendix 3.7	Preparation of the Dichotic Test	310
Appendix 3.8	Preparation and Piloting of the Sentence Monitoring Test	317
Appendix 3.9	List of Variables from Stage II	325
Appendix 3.10	Reliability Matrices	329
Appendix 4.1	Questionnaire for Consultants' Assessment of the OAD Clinic	335
Appendix 4.2	Questionnaire for Patients' Assessment of the OAD Clinic	339
Appendix 4.3	Programme for OAD Course	341
Appendix 5.1	Letter sent to Patient-Controls	342
Appendix 6.1	Self-Rated Auditory Disability and Handicap Sub-scales	343
Appendix 6.2	Distributions of scores on variables from stage II	345
BIBLIOGRAPHY		365

ACKNOWLEDGEMENTS

I would like to thank all friends and colleagues at the Institute of Hearing Research for their helpful comments, but in particular:

Mark Haggard for his support, encouragement and enthusiasm with the supervision of this work, and for his amusing comments on some draft versions of the thesis.

Poul Lyregaard for his valuable comments and advice throughout the project, and Oticon for part-funding this work.

Dave Bullock for his invaluable technical assistance, especially in times of crisis.

John Foster for callibration and much other practical assistance.

Diana Field and Eileen Sloan for their help with the testing of subjects.

Stuart Gatehouse and Mark Lutman for their helpful comments about various portions of the thesis.

Angela Perdue, Christine Holland and Sue Corner for typing umpteen appointment letters and patient reports.

All ENT Consultants from the Trent Region Health Authority who referred patients to the Special Investgative Clinic.

Mr Sears, Mr Edington, Sister Dallison and the Nurses of Ward C31 for providing me with names and addresses of one subject group.

Finally, I would like to thank my family and friends for their encouragment and support while I remained "the eternal student".

ABSTRACT

A proportion of individuals consulting audiology clinics complain of difficulties discriminating speech in noisy environments but have clinically 'normal' hearing, do not have signs of middle ear pathology, nor any other obvious basis for their complaints. The syndrome was named 'Obscure Auditory Dysfunction (OAD)'.

Following a small scale study, a Special Investigative Clinic was started to investigate factors underlying OAD. Patients' performance on psychoacoustic, central/cognitive and personality-related tests was compared with the performance of matched controls. Results showed OAD to be a multifactorial syndrome. Patients have a genuine performance deficit for discrimination of speech-in-noise, influenced by a combination of psychoacoustic and central/cognitive deficits. Patients' relatively minor performance deficit did not completely explain their reported disability and handicap; this was mainly influenced by their underestimating their hearing ability. Anxiety-related factors and a history of otological disorder were found to underlie the seeking of medical attention. Based on these results, a clinical package was devised to enable diagnosis and understanding of OAD in individuals consulting in the clinic.

The parallels between OAD and another syndrome without obvious organic pathology (women complaining of lower abdominal pain) were investigated. A double dissociation between personality-related factors and psychoacoustic/cognitive factors was demonstrated. It was concluded that personality factors should be considered

when dealing with individuals seeking medical advice for minor organic pathology, but that such individuals should not simply be dismissed as being neurotic.

Finally, correlational analyses using the combined data of all subjects, were carried out to investigate relationships between self-rated auditory disability/handicap, psychoacoustic, central/cognitive and personality-related variables. Self-rated disability/handicap were found to correlate best with performance on a test of speech-in-noise, less well with subtle auditory function but not with pure tone sensitivity. Cognitive function also correlated with reported disability/handicap, as did anxiety level and otological history. It was concluded that performance measures could be used to validate reports of disability/handicap, but that personality factors should be taken into account when interpreting such reports. Performance on a speech-in-noise test correlated with psychoacoustic and central/cognitive functions, but not with personality factors. It was concluded that minor sensory dysfunction can be reflected in a sensitive performance test but that performance is not affected by 'normal' personality traits.

CHAPTER 1

1.1 INTRODUCTION

This thesis concerns the investigation and characterisation of a sub-group of the many adult ENT patients who complain of considerable difficulties hearing speech in the presence of background noise. The individuals in this sub-group are audiometrically normal, i.e. they are found to have pure tone thresholds within clinically defined "normal limits". Normality is not always defined precisely, but a fairly stringent definition, as used in this study, is similar to that recommended by the British Society of Audiology (BSA, 1988): no threshold greater than 20dB for frequencies 0.25, 0.5, 1.0, 2.0 & 4.0kHz¹. In addition patients do not have signs of middle-ear pathology, nor are there any other obvious causes (e.g. stroke) for their difficulties. These patients constitute a small but non-trivial proportion of ENT consultations. An unpublished study by Coles et al found that of those adult otological referrals to an ENT clinic in the UK not having specific middle-ear pathology (i.e. about half) approximately 10% (i.e. 5% of all adult referrals) had pure tone audiograms with a better-ear average of ≤ 20 dBHL at 0.5kHz, 1kHz, 2kHz and 4kHz. I have called this previously unlabelled syndrome 'Obscure Auditory Dysfunction - OAD²'. This name is deliberately non-specific to avoid implying any one particular cause of the syndrome, especially given the likelihood of several underlying factors, as discussed below.

¹The BSA definition uses average threshold rather than individual thresholds.

²From here onwards, the term 'OAD' is used to refer both to the syndrome itself and to patients with the syndrome - i.e. OADs

The aims of the thesis are both scientific and clinical. In the absence of any conventional explanation for these patients' hearing difficulties, the first aim is to understand the bases of the syndrome, in particular, to specify the factors which prompt OAD patients to seek medical attention for their hearing difficulties. This latter information can then be used to address the second aim - to devise a short package of tests and interviews to enable quick diagnosis, characterisation and improved counselling of OAD patients in ENT clinics.

1.2 LITERATURE REVIEW

The following literature review is divided into two sections: (i) the few studies relating directly to the investigation of individuals with OAD-like symptoms, and (ii) studies that cover issues hypothetically related to OAD.

1.2.1 RESEARCH DIRECTLY RELATING TO OAD

Otolaryngologists readily acknowledge the existence of, and the difficulty of dealing with, OAD patients in the clinic. However, OAD has not, until very recently, been recognised as a syndrome in its own right; hence past research relating directly to OAD is scant. I have found only one reference in a standard text book, to date, referring to the existence of the syndrome (Byrne & Kerr, 1987). It is brief and only refers to one empirical study (Pick & Evans, 1983). Byrne & Kerr suggest three possible

causes of the syndrome: an 'auditory inferiority complex', a loss of frequency resolution or an early stage of tumour affecting the auditory pathway. They point out that such patients are usually given simple reassurance that their hearing is normal and then dismissed from the clinic; and that in the last (rare) sub-group, patients may be experiencing the early symptoms of sinister pathology and should, therefore, not be dismissed as being neurotic.

A small number of empirical studies have addressed restricted aspects of the OAD problem. These studies can be divided into three categories.

1.2.1.1 Psychoacoustic Studies

A single study, published prior to the commencement of this work, involved a group of individuals that may be retrospectively classified as having OAD (Pick & Evans, 1983) by the above criteria. This study was not a clinical characterisation but a psychophysical investigation of an apparent dissociation between auditory sensitivity and other psychoacoustic functions. They tested 16 patients, referred by hospital consultants, whom they 'felt were suitable to take part'. Each carried out a small battery of tests: pure tone audiometry for frequencies between 0.1 and 10kHz, frequency resolution at 1kHz and 4kHz, and speech perception in noise and in quiet. They found that, although patients had pure tone audiograms within 'normal limits', they often displayed high-frequency notches. Patients were found to have widened auditory filters at 4kHz (although not at 1kHz) and significantly poorer than

normal speech perception ability in quiet (although, surprisingly, not in noise). Pick & Evans conclude that poor frequency resolution can account for the patients' poor speech perception in quiet.

The majority of subjects in Pick & Evan's study had a significant history of noise exposure. This may well have influenced their findings since many studies, for example, Liberman & Beil (1979), Harrison et al, (1981) and Rutten & Kuper (1982) have shown that, in both animals and humans, noise damage causes a widening of the auditory filters. In some circumstances measurement of frequency resolution could well be a more sensitive reflection of minor auditory dysfunction than is pure tone sensitivity. This might explain the basis of OAD in some patients, but it is not likely a priori that the majority have noise-related dysfunction, else the syndrome would mainly be restricted to males who work in noisy industries.

Narula & Mason (1988) have also suggested that the basis of OAD is poor frequency resolution. They compared the frequency resolution of 10 patients with OAD symptoms with 10 unmatched controls, using both a behavioural and an electrophysiological technique. A psychophysical tuning curve (PTC) was measured at 2kHz using a psychophysical paradigm, and an action potential tuning curve (APTC) was measured at 4kHz using extratympanic electrocochleography. They also tested speech audiometry and tone- and reflex- decay. They found that patients had normal speech audiometry, no significant tone or reflex decay and normal PTCs. Abnormalities of the APTC, both in width and in elevation in relation to threshold, were seen in the patient group. However, no details were given of the distributions of the APTC parameters nor the

relevant selection characteristics of the control group. They conclude that the basis of OAD in some patients is poor frequency resolution, but they acknowledge an earlier suggestion (Saunders & Haggard, 1987) that this cannot explain the basis of OAD in all patients. While this study does not assist with the general problem of clinical assessment and management of OAD patients, it is valuable in showing that a physiological method of measurement can be more sensitive to certain minor abnormalities of function than a behavioural method.

One study has shown an OAD-like phenomenon to exist in a population that had not sought clinical investigation. Earl et al (1987) administered a questionnaire on perceived auditory disability to 27 subjects (6 male and 21 female) with clinically normal audiometry (pure tone thresholds of ≤ 15 dBHL). No other information about the selection of subjects is given. Nine subjects reported significantly more auditory disability than normal. They labelled these 'normal-abnormals (NAs)'. The remaining 18 were labelled 'normal-normals (NNs)' and were used as controls. They measured masking level differences (MLD¹) at 0.25kHz, 0.5kHz and 1.0kHz, the bandwidth of effective masking and the slope of the masking curve for a 100Hz wide narrow-band noise at centred at 2kHz, frequency of the peak of the masking curve, monaural and binaural word identification in noise, both with and without reverberation, and the improvement in performance for binaural over monaural presentation. They found that the NA group had significantly lower MLDs at all frequencies tested, and significantly greater upward spread of masking plus a higher peak frequency of the masking curve

¹ A measure of ability to use subtle interaural difference cues in detection and localisation

(both manifestations of poor frequency resolution). Performance on the speech tests did not differ significantly between the 2 groups. Discriminant function analysis showed that MLD and masking curve data are able to correctly classify all 18 of the NN subjects and 7/8 of the NA subjects into their appropriate group; this is an overall percent-correct classification of 96.3%. They conclude that patients complaining of auditory disability with normal pure-tone thresholds have degraded frequency resolution and poor binaural abilities, and should, therefore, be administered these tests on presentation at a clinic.

Studies on animals by Evans (1975) showed that chronic poisoning of the cochlear with kanamycin can cause a deterioration of tuning bandwidth before substantial change in hearing threshold occurs. Similarly, Young & Wilson (1982) showed that after ingestion of large quantities of acetylsalicylic acid (Aspirin) speech perception in noise deteriorated, but hearing threshold and speech perception in quiet did not. Thus there is evidence suggesting that some measures of frequency resolution can detect some forms of mild pathology, other than noise damage, when tests of pure tone sensitivity cannot. Furthermore, these forms of ototoxicity occur from commonly used drugs, and so are worth considering as the basis of OAD in at least some cases of OAD.

1.2.1.2 Central/Cognitive Studies

Cunningham et al (1987) suggest that deprivation of oxygen to healthy tissue of the brain may explain the presentation of some patients classifiable as OAD. They

tested this hypothesis by comparing the auditory abilities of 15 men diagnosed as having a history of chronic obstructive pulmonary disease (COPD) with a group of 15 healthy, non-smoking controls. All participants in the study had normal pure-tone thresholds for their chronological age. Tests of central auditory function, speech discrimination in quiet, pulmonary function tests and arterial blood analyses were carried out. The COPD group performed significantly more poorly than controls on a competing message test when the competing message was ipsilateral to the target message, and on a test of auditory attention span. Correlations among the COPD group suggested that relatively poor tissue oxygenation and heavier cigarette smoking are associated with poorer central auditory function. They conclude that subclinical oxygen deprivation due to smoking, high dietary fat intake, sedentary life-styles and airborne pollutants could also explain minor sub-clinical cognitive deficits, and hence the presence of some OAD-like patients in the clinic.

While effects of oxygen deprivation are generally assumed to affect the central nervous system, peripheral effects cannot be ruled out since all tissues are dependent upon oxygen supply for metabolism. Nevertheless, I later classify the variables referred to by Cunningham et al as potentially having influence upon central, rather than peripheral processing.

Quaranta (1988) found that young audiometrically normal individuals with hypothyroidism had central auditory deficits during their illness. Quaranta (personal communication) suggests subclinical hypothyroidism could have similar effects.

1.2.1.3 Multifactorial Studies

Stephens & Rendell (1988) report a study of 12 patients they refer to as having 'Auditory Disability with Normal Hearing' (ADN) - equivalent to OAD. The approach and some of the tests used in that study were made available to Stephens & Rendell following stage I of the present project. Stephens & Rendell's aim was to clinically classify patients as having psychological, cognitive or acoustic problems. They did not compare ADN patients with a control group. They conclude that the majority of patients have mild cochlear dysfunction in association with psychological problems. This clinical study is of relevance here, in that it confirms the *a priori* assumption that OAD is multifactorial. However, the lack of a control group, the small sample size, and the large number of tests in their battery mean that no firm conclusions can be drawn about causal factors or about appropriate cut-off points for test scores.

The above short literature review covers all known past and present publications on OAD. The only publication, directly or indirectly, tackling the issue of OAD at the start of this project was that of Pick & Evans (1983); all the other work reviewed above has been published since.

1.2.2 RESEARCH HYPOTHETICALLY RELATED TO OAD

1.2.2.1 Psychoacoustic Explanations

(a) Frequency Resolution

Frequency resolution is the ability to separate out the different frequency components of a complex sound; it is the main factor determining which sounds mask one another and which do not. It is accepted that frequency resolution is a peripheral mechanism taking place in the cochlear. The basilar membrane in the cochlear acts as a bank of highly tuned, overlapping bandpass filters (Moore, 1985). Damage to the cochlear causes both an elevation of the thresholds required for neural responses, and a broadening of the auditory filters. The latter damage causes increased masking from non-signal sources, and hence difficulties with hearing speech in noise. Some of the psychophysical procedures for measuring frequency resolution ability are reviewed in the section 2.2.2(a). Much psychoacoustic research on cochlear-impaired listeners has demonstrated a relationship between frequency resolution, pure tone sensitivity and speech in noise discrimination (e.g. Tyler et al, 1982a; Moore 1985; Haggard et al, 1986). Evidence is equivocal, however, as to how independent frequency resolution is of hearing sensitivity. Tyler et al (1982a) and Lyregaard (1982) for example, suggest they are highly interrelated, while Festen & Plomp (1983), Pick & Evans (1983) and Haggard et al (1986) have shown instances where this is not so. These discrepancies are probably due to the measures and subject populations used. To the extent that the two are independent, deteriorated frequency resolution in the OAD syndrome is

a highly plausible explanation.

(b) Excessively Strict Clinical Definition of Normality

There are various definitions of clinically 'normal' hearing. 'Normal' hearing implies that the listener has no material impairment great enough to cause material auditory disability - i.e. no material restriction of normal activity or ability as a result of impairment; likewise no material handicap - no restriction of role or socioeconomic function as a result of a disability (World Health Organisation, 1980a). Auditory normality is defined in terms of the level of pure tone threshold that does not cause impairment. The most commonly used definition in the UK is that recommended by the British Society of Audiology - thresholds of less than 20dB at frequencies of 250, 500, 1000, 2000 and 4000Hz (BSA, 1988). The World Health Organisation, on the other hand uses the less stringent definition of thresholds of 25dB or less for frequencies of 500, 1000 and 2000Hz (WHO, 1980b). However, recent work, using measures of pure tone sensitivity, speech perception in noise and self-assessed auditory disability suggests that the low fence or "onset" of disability occurs at pure tone losses of between 10 and 20dBHL (e.g. Smoorenburg, 1986; Lutman et al, 1987; Haggard et al, 1987). It is possible that those OAD patients meeting the BSA definition of normality, but with pure tone averages at the upper end of the 'normal' range, in the region of 15-20dB, experience auditory disability as a direct consequence. This explanation seems particularly plausible when findings of Merluzzi & Hinchcliffe (1973) are considered. They report that the cut-off point, in terms of hearing level, at which an individual replies positively to the question "my hearing

is not a good as it used to be" increases as a function of age. Individuals seem to expect less from their hearing they get older. The age of all OADs in this study is restricted to between 15 and 55, i.e they are all relatively young, and therefore probably have high expectations about their hearing, and so might 'perceive' auditory disability/handicap at lower thresholds than do older individuals.

1.2.2.2 Central and Cognitive factors

(a) Lipreading Ability

At adverse signal-to-noise ratios, visual cues (i.e. lipreading) contribute considerably to audiovisual speech intelligibility (e.g Sumbly & Pollack, 1954; McLeod & Summerfield, 1987). It is therefore possible that OAD patients are poor lipreaders; and that their reported disability arises particularly from experiences of difficult acoustical conditions where audiovisual perception is called for, and where better lipreaders do not have evident problems.

(b) Linguistic Abilities

Speech processing involves the use of both auditory and linguistic abilities. Under good acoustic conditions, when the S/N ratio is favourable, auditory abilities can be relied upon. However, when the acoustic signal is poor, such as in conditions of adverse S/N ratio, auditory abilities must be supplemented by linguistic abilities. General linguistic processing ability has been

shown to vary considerably between individuals. Some examples are as follows: Geer et al (1972) demonstrated large individual differences in the ability to produce and recognise paraphrases of novel compound nouns; Murphy (1973) discusses individual differences that influence 'general linguistic fluency'; and Marslen-Wilson (1975) has shown that individuals vary considerably in the speed with which they can 'shadow' a spoken sentence, i.e give simultaneous spoken feedback. This relates to speed of linguistic processing. It is possible that OAD patients are generally poor linguistically, and therefore, when these skills are required in for processing in adverse signal conditions they are at a disadvantage compared to normal individuals.

(c) Linguistic/Cognitive Deficits due to Childhood

Otitis Media

The importance of early auditory input for later cognition, language development and social growth has been well documented (e.g Horowitz & Leake, 1980). Therefore, the fluctuating, though mild, conductive losses caused by childhood otitis media, may, through auditory deprivation, have adverse consequences for later achievement, both linguistically and socially. The literature in this area is wide ranging and controversial (See Haggard & Hughes, 1988 for review). They point out that interpretation of the majority studies encounters problems such as failure to control for socio-cultural factors and/or hearing at the time of the test, non-blind ratings, and small numbers of subjects, to mention but a few. Nevertheless, some well controlled studies (e.g Silva et al, 1982; Gottlieb et al, 1979) report that in young children there is an association between recurrent

otitis media and significant linguistic and cognitive deficits. However, Silva et al, (1986) found that by the age of 7 many differences had disappeared, and by age 9, only differences in speech articulation remained significant. There is the possibility that a proportion of OAD patients suffer long-term consequences of childhood otitis media in their language processing and in general social skills. This would, however, be very difficult to prove with a small number of patients. It would be necessary to show them to have poor verbal intelligence, but average non-verbal intelligence, and a strong, well-documented history of otitis media, but to rule out any residual organic pathology, which is in principle virtually impossible.

1.2.2.3 Personality-Related Factors

(a) Personality Factors Relating to General Health Beliefs

Factors such as 'perceived vulnerability' and 'perceived severity' of a potential health problem determine whether or not an individual seeks medical attention for a set of symptoms (Janz & Becker, 1984, review this literature.) In a study of children and adolescents, Gochman & Saucier (1982) showed that an individual's perceived vulnerability is positively related to anxiety, and negatively related to self-concept. In a questionnaire study on preventive health behaviour (PHB), Kristiansen (1985) found that introversion, rather than extroversion, led to greater PHB. Mechanic (1980) reports three main factors that lead individuals to classify themselves as ill, of which one is the lack of 'a general sense of

well-being'. OADs could be anxious introverts who have a high perceived vulnerability and hence seek medical attention for relatively mild symptoms; or they could be slightly depressed, with a poor sense of well-being and, hence, have noticed symptoms of illness. The factors mentioned are not specific to hearing but are general to all types of illness. Noticing and reporting hearing problems might be just one of many manifestations.

A familial history or a childhood history of a particular illness might cause an individual to feel more vulnerable to that illness later in life. Wielgosz & Earp (1986) showed this among individuals experiencing persistent chest pain in the absence of coronary disease. They found that those who identified with a close relative who had serious heart disease felt more vulnerable to coronary disease than those who did not. Likewise OAD patients could well have a strong familial or childhood history of hearing disorder and hence feel vulnerable to it now. However, this suggestion is not supported by the findings of Swan & Gatehouse (1988). They found no significant differences in the prevalence of family history or personal history of ear disorder, between groups of 'complainers' and 'noncomplainers' of auditory disability, both of which had conventional hearing losses. Their results had been controlled for the actual impairment of the subject groups. Similarly, Lutman et al (1987) report that past consultation for hearing-related disorders did not correlate with self-rated disability or handicap.

(b) Personality Factors Relating Directly to Hearing Problems

It has been argued that there is a link between personality and susceptibility to noise-induced hearing loss (Ickes & Nader, 1982; Dengerink et al, 1982). Both sets of authors suggested that the degree of vasoconstriction of the inner ear blood vessels would influence noise-induced temporary threshold shifts. Ickes & Nader postulated that type A individuals (i.e. ambitious, competitive and pressured, allegedly prone to cardiovascular disease), who show a greater degree of noise-induced peripheral vasoconstriction, would therefore be more susceptible to noise-induced hearing loss than type B individuals. Their results, however, showed a significant difference in the non-predicted direction. Dengerink et al suggested this could be because peripheral vasoconstriction is accompanied by central vasodilation and therefore type B individuals would be more susceptible. However, on investigation they were unable to show a relationship between personality type and noise-induced threshold shift. Temporary threshold shift was negatively correlated with peripheral vasoconstriction, suggesting that any different set of personality factors found to be associated with vasoconstriction might still be linked with susceptibility to noise-induced hearing loss.

Anxiety has been associated with some types of ear disorder, for example vertigo. Fowler & Zeckel (1952, 1953), for instance, showed that an attack of vertigo could be induced in Meniere's patients by exposing them to emotional stress. Hinchcliffe (1967) found Meniere's patients to have significantly more psychosomatic symptoms (as defined by the MMPI) than otosclerotic

patients. He also found that more severe physiological symptoms in Meniere's patients were associated with less severe psychological disturbances and vice versa (Hinchcliffe, 1965), suggesting an interplay of abnormal physiology with abnormal psychological makeup.

Jakes (1987) suggests that emotional distress might act upon hearing performance by causing a vicious circle involving expectation of failure. He says that all people have difficulty hearing speech-in-noise sometimes. In some that difficulty might cause anxiety and hence worsen the problem. These individuals might then begin to experience anxiety every time they are required to hear speech-in-noise, regardless of their actual performance, and hence perform more poorly than they would have without the anxiety. Some OAD patients might experience a cycle of this sort when in certain situations, but ones that are not encountered in the clinic, hence their normal performance.

(c) Personality Altering Judgement of Hearing

Personality traits may cause an individual to judge their hearing ability incorrectly, or to subjectively experience greater disability and handicap than another individual with the same degree of actual impairment. Marcus-Bernstein (1986), for instance, showed that self-assessed hearing handicap among a hearing impaired elderly population, was positively related to level of depression and paranoia, but negatively related to life satisfaction. She suggests that these findings are applicable to other populations as well. OAD patients might have these traits, and therefore, experience auditory disability and handicap, even though they have

normal hearing.

If overall associations between personality-related factors and OAD are established it will be almost impossible to determine whether they are the cause or effect of the problem, or are an independent parallel influence.

1.2.3 SUMMARY

This literature review strongly suggests that it is likely no single underlying basis for OAD will be found, but that there will be a spectrum of explanations, ranging from those mainly sensory in nature, with only minor psychological influences, to those mainly psychological in nature in which sensory factors play little role. It also highlights the importance of adopting an multidisciplinary stance when commencing a project such as this.

CHAPTER 2

2.1 INTRODUCTION

This chapter describes the first stage of the OAD project. The aim of stage I one was to carry out a small scale study to elucidate the types of factors involved in the syndrome that would be investigated in greater depth in stage II.

As the literature review in chapter 1 suggests, there are many factors that possibly influence self-rated disability/handicap and OAD status. In the following section is a description of those factors investigated in stage I of the study. In addition to investigating the underlying influences on OAD, the protocol must include a check that all referred patients have true OAD status, i.e. all patients must have thresholds within the given criteria (as defined in section 1.1), confirmable subjective disability to account for their referral and no other obvious cause for their complaints.

2.2 FACTORS INVESTIGATED

2.2.1 General Factors

(a) Subjective Disability

Subjective disability is commonly assessed with a self-report questionnaire. There are numerous such scales (e.g High et al, 1964; Noble & Atherley, 1970; Giolas, 1979). These have been mainly employed clinically in the assessment of hearing aid benefit (Brooks, 1976) and in

research to underpin medico-legal procedures, such as defining the audiometric "onset" of auditory disability (Parving & Ostri, 1983; Lutman et al, 1987). Self-report scales are convenient to use, but are subject to bias from factors such as deliberate exaggeration, personal opinion, incorrect self-perception and invalidity of the test scale itself. A self-report scale was employed here for three reasons: first, to check for OAD status; i.e to check that patients do have a higher level of self-reported disability and handicap than controls; second, to test whether OADs report relatively greater disability/handicap than would be expected from their actual performance disability, and thirdly as a indication of the 'severity' of OAD in a particular patient (This is discussed further in section 4.4.4.)

(b) Performance Disability

It is of importance to learn whether patients have a genuine, as well as a reported, deficit for speech discrimination in noise. This will reveal whether the OAD syndrome has a performance basis or whether it is purely psychological. There are many tests of speech-in-noise, employing various stimuli and maskers (See Lutman, 1987 for review). An ideal test would reproduce perfectly the auditory conditions of the real environment, for example stereophony and reverberation. Free-field presentation of stimuli can do precisely this, however, such tests are difficult to calibrate and have poor reproducibility, due to room acoustics and subject positioning. Gatehouse (1988) designed a speech-in-noise test that was recorded from microphones in the ears of an artificial head. These recordings retain realistic free-field localisation cues

when replayed through headphones. The test has the benefits of being pre-recorded, while offering the realism of free-field presentation. The test was used in the investigation of OAD.

The following factors were investigated to learn the underlying influences on OAD. For ease of understanding they are divided into three major categories or domains.

2.2.2 Minor Auditory Pathology

While OAD patients by definition have audiometrically 'normal' hearing, there exists the possibility that minor peripheral auditory dysfunction influences OAD in one of the following three ways:

(a) Poor Frequency Resolution

As described in chapter 1, research, both directly and indirectly addressing OAD, suggests that poor frequency resolution may be a major component (e.g. Narula & Mason, 1988; Moore, 1985). There exist many ways to measure frequency resolution ability, for example, the notched-noise technique developed by Patterson (1976), and the 'comb-filtered noise' method used by Houtgast (1977) and Pick & Evans (1983) and the electrophysiological technique used by Narula & Mason (1988). Moore (1985) has provided a review and critique of some of these methods. A fourth technique was developed by Zwicker (1974) and Vogten (1974) to measure a psychoacoustical tuning curve (PTC). The subject is presented with a tone of fixed

frequency and level. The masked threshold of that tone is determined for narrow-band maskers of different frequencies. A plot of masked threshold against masker frequency constitutes the PTC. When tone and masker are of the same or similar frequency masker level is necessarily low, as the difference between frequency of the tone and masker increases, a greater level of noise can be tolerated. Lutman & Wood (1985) developed a simple clinical method using an adaptive procedure¹ for measurement of a three-point approximation to a PTC. Their method is quick, simple (even for naive listeners) and can be used for individuals with differing pure tone sensitivities. This method was employed to test frequency resolution ability.

(b) 'Incorrect' Definition of Normality

As described in chapter 1 there are various definitions of clinically 'normal' hearing; the World Health Organisation, for instance, uses the definition thresholds of ≤ 25 dBHL for frequencies of 0.5, 1.0 and 2.0 kHz (WHO, 1980b), while the most commonly used definition in the UK, as recommended by the the British

¹In an adaptive procedure the difficulty level of a stimulus is determined by the accuracy of the response to the previous trial, so that the difficulty of the task converges upon a specific point on the psychometric function. This point is the level of difficulty at which the individual would correctly identify a specific percentage of the stimuli if the test was run at a constant level. The precise point on the psychometric function that is reached depends upon the particular rules used for altering the signal intensity. The accuracy of the result depends upon the asymptotic step-size employed and the stringency of the criterion for convergence, such as the number of reversals (Levitt, 1971).

Society of Audiology, is average threshold of ≤ 20 dB for frequencies of 0.25, 0.50, 1.0, 2.0 and 4.0kHz (BSA, 1988). Most researchers in the auditory disability field believe that this 'fence' is set too high, and that the onset of auditory disability/handicap occurs below this (e.g. Smoorenburg, 1986). OAD patients might meet the BSA definition of normality, yet have pure tone averages of between 10 and 20dBHL; if so some of them would experience auditory disability due to mild impairment. There is the second possibility that OAD patients could have 'normal' pure tone thresholds at the frequencies conventionally used to define normality, yet have pure tone losses at other frequencies, for example at 3 or 6kHz. Therefore, pure tone thresholds were carefully measured at frequencies of 3 and 6kHz, in addition to the conventional frequencies of 0.25, 0.5, 1.0, 2.0, 4.0 & 8kHz.

(c) Minor Auditory Damage due to Noise Exposure

Long term exposure to high levels of noise can lead to significant damage to the auditory system (see Alberti, 1987 for review), in particular it can lead to permanent high-frequency hearing losses at 4 and 6kHz. Other work has shown that noise damage causes structural damage to hair cells (Saunders et al, 1985), neural damage (Liberman & Mulroy, 1982) and biochemical damage (Schacht & Canlon, 1985). Pick & Evans (1983) concluded that noise caused cochlear damage in the form of poor frequency resolution, before it caused an elevation of pure tone thresholds. It is possible that, like many of Pick & Evans' subjects, some OAD patients have auditory dysfunction caused by noise exposure, but have normal pure tone thresholds. An account of each individual's

history of noise exposure was therefore taken, because even in the absence of present physiological evidence, there might be a tendency for subjects to have a history of noise exposure, that eventually will manifest itself physiologically.

2.2.3 Central/Cognitive Processing Deficits

(a) Poor Lipreading Skills

Both normal-hearing and hearing-impaired individuals use visual clues (i.e lipreading) to supplement auditory information during speech processing. Early work on individual differences in lipreading ability was assessed using 'visual-only' conditions (e.g Utley, 1946) However, it has been realised more recently that lipreading is used as a supplement to, rather than a substitute for, auditory information (Jeffers & Barley, 1971). Therefore, as suggested by, for example, Erber (1975) and McCormick (1979), lipreading ability was measured using an audiovisual test.

(b) Poor Linguistic Ability

As mentioned in Chapter 1, individual differences occur in linguistic ability, in terms of size of vocabulary, ability to manipulate language, and in the speed and efficiency of language processing. Individual differences in some aspects of linguistic ability could, therefore, be measured in a variety of ways. The Wechsler Adult Intelligence Scale - WAIS (Wechsler, 1958), for which

there are established norms, includes a subset of tests that result in scores of overall verbal IQ. However, to carry all of them out would be time-consuming. It is also not clear whether these tests reflect real-time and real-life linguistic processing. For the purposes of this project a quick and simple test was used that gave a measure of overall ability, combining speed of processing, use of contextual information and linguistic versatility.

(c) Central Auditory Deficit

The work of Silva (1988), Quaranta (1988) and Cunningham et al (1987) reviewed in chapter 1, showed that otological, general medical and dietary history respectively can affect central auditory processing. Questions relating to each of these factors were included in an interview.

2.2.4 Personality-Related Factors

(a) Personality and Concern about Health/Hearing

As discussed in chapter 1, certain clusters of personality traits seem to give rise to excessive concern about health; while past experiences cause an individual to feel particularly vulnerable to hearing disorders. Therefore questions about general health and past, present and familial hearing disorder were incorporated in the interview.

(b) Personality Altering Perception of Own Hearing Ability

Depression and anxiety have been shown to affect the degree of hearing disability an individual reportedly experiences. A personality questionnaire, including scales of depression and anxiety was included in the test battery.

2.3 METHODS

2.3.1 Subjects

OAD patients were referred to a clinic at the Institute of Hearing Research by 10 ENT consultants in the Trent Health Region of England. This region approximates a circle of about 40 miles radius in the North-East Midlands, centered on Nottingham. ENT consultants were informally told of the research project during a regional meeting and then in a follow-up circular. They were given details of the aim of the project and of the patients they should refer. The age range of the 20 patients included was 16 to 55 years. An upper limit of 55 was set in order to avoid cases of degenerative, neural or cardiovascular pathology. It was required that each patient had proved audiometrically and otologically 'normal' on all tests in the hospital clinic. For each patient, two control volunteers, matched for age, sex, educational level and noise exposure were tested, giving a total of 40 matched controls. They were recruited by placing advertisements in various locations around the city and the university campus of Nottingham.

The educational level of individuals was classified on a scale of 1 - 6 by the highest qualification obtained, as follows:

1 = Degree	2 = Diploma	3 = 'A' Level
4 = 'O' Level	5 = CSE	6 = No qualifications

2.3.2 General Procedure

Before each test subjects were given standard verbal instructions by the investigator. In addition, a summary 'prompt sheet' of instructions was left in the test room with the subject. Table 2.1 summarises the test battery.

Testing was carried out in one session for all OAD patients and most controls. When necessary testing took place in two sessions. The total testing time was 2 hours, including a short refreshment break. Tests were carried out in the same order for most subjects, to minimise the effects of fatigue. All participants were paid travel expenses. In addition controls received payment for taking part.

All tests of psychoacoustic and performance ability were carried out in a sound-attenuated room.

Table 2.1
Summary of tests in the OAD Test Battery Stage I

TEST	EXPLANATION
Interview	Biographical, health and information about past and present ear disorder. Patients' response to, and acceptance of their problem.
IHR Hearing Questionnaire	Self-rated auditory disability and handicap
Pure Tone Audiogram	Pure tone threshold determination
Tympanometry	Test of middle ear function
Psychoacoustic Tuning Curve (PTC)	Frequency resolution ability
Noise Immission Rating	Quantification of noise exposure
Pseudo-free-field in Noise Test (PFFIN)	Test of speech-in-noise under spatially realistic conditions
Audiovisual Test (BKBAV)	Test of audiovisual ability
Sentence Completion Test	Measure of general linguistic ability
Crown-Crisp Questionnaire	Personality Inventory

2.3.3 Test Battery

2.3.3.1 General Tests

(a) Special OAD Interview

The interview was designed to incorporate questions on 5 types of information:

(i) Biographical Information:

Age, sex, educational qualifications, employment

(ii) Medical History:

General physical health, personal opinion of own health, specific cardiovascular and respiratory pathology, present medications, past and present otological symptoms, family history of otological disorder, and attitudes to preventive health.

(iii) Personality Scales of:

Somatic anxiety symptoms, extroversion traits

(iv) Factors that Might Influence Central Auditory Function:

History of smoking and/or working in poorly ventilated workshop, linguistic learning difficulties.

(v) Details of Hearing Difficulty:

Symptoms of problem, history of problem, reaction to problem, factors associated with seeking medical assistance, handicap caused by problem (only applicable to patients)

The final interview is in appendix 2.1.

Procedure

The interview questions were read from a printed sheet in order to standardise the wording. The subject was prompted with examples when there seemed to be uncertainty as to the meaning of the question. Section (e) relating to hearing difficulty was omitted when testing control subjects.

(b) IHR Hearing Questionnaire

This questionnaire has been widely used in the NSH (Davis 1983a). It indicates the level of auditory disability and handicap an individual reportedly experiences. Its purpose here is two-fold: first to confirm that OAD patients report a higher level of disability and handicap than controls, and second to investigate whether among OADs there is a mis-alignment between self-rated disability and measured disability. The questionnaire consists of 3 types of questions with multiple-choice answers. Type (i) comprises 14 disability questions, type (ii) 3 handicap questions; and type (iii) 2 questions that attempt a comparison with others' hearing ability. Subjects completed the questionnaire by circling the appropriate answers.

(c) Performance Test - the Pseudo-Free-Field in Noise Test (PFFIN)

This test is intended to be a sensitive and realistic test of auditory disability for speech-in-noise. Its

purpose is to learn whether OAD patients have a genuine disability for comprehension of speech-in-noise, and therefore, a genuine basis for their reported disability.

Stimuli

The stimuli are 5 lists of 16 simple English sentences (BKB sentences) devised by Bench & Bamford (1979). Sentences were played from master tapes into a sound-treated room and re-recorded from microphones in the ears of a dummy head, as described by Gatehouse (1988). On replay through headphones these recording conditions result in the speech stimuli seeming to be distinctly spatially located. Depending on the azimuth of the source of the speech with respect to the dummy head, this localisation was 45 degrees to the left or to the right of the head, called 'left ipsi' or 'right ipsi' respectively. Speech-spectrum noise was played through 6 loudspeakers surrounding the head at recording, so that at replay noise appears to be located all around the head (see figure 2.1 for the setup during recording). The equipment was calibrated so that channels 1 and 2 (speech signals) were at a level of 70dB, while channel 3 (noise) total output was 64.5dB, i.e. an overall S/N ratio in all conditions of +5.5dB.

Procedure

The sentences were played to the subject through Sennheiser HB414 headphones. Subjects were required to repeat back each sentence after they had heard it. The first list of sentences was run as practice. Sentences 1-5 had only signal. Noise was then introduced for the remaining sentences. In the 4 test lists, 'left ipsi' and

Figure 2.1 Recording Conditions for the Pseudo-Free-Field Speech-in-Noise Test

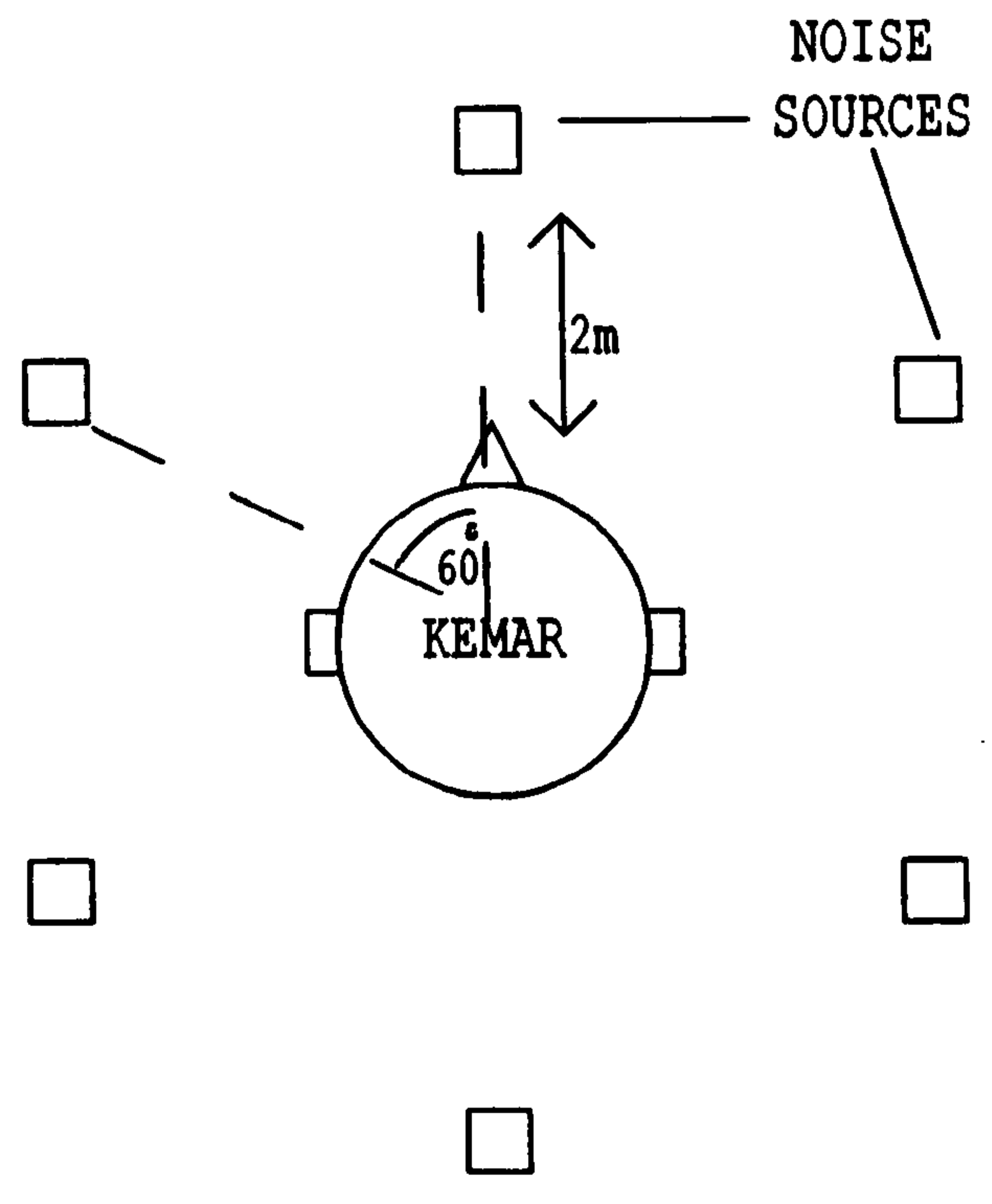
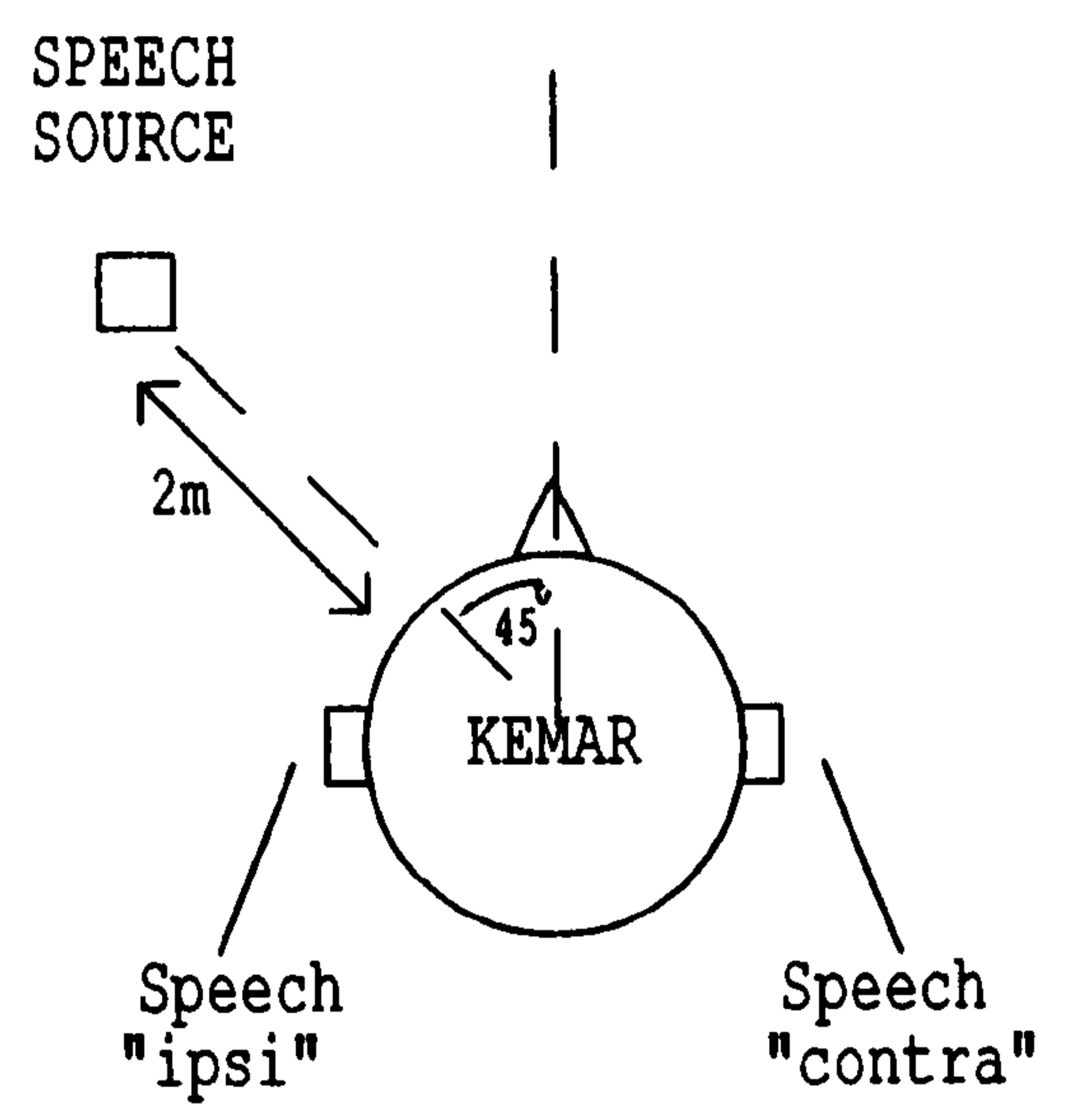

'right ipsi' conditions were presented counterbalanced across subjects in ABBA or BAAB sequence. Sentences were scored on the number of key words correct out of a possible 50. The 'loose key-word' method of scoring was used¹.

2.3.3.2 Psychoacoustic Tests

(a) Pure Tone Audiogram

Absolute thresholds were determined using a conventional clinical technique, as recommended by the British Society of Audiology (BSA, 1981). Both ears were tested at frequencies of 250 & 500 Hz, and 1, 2, 3, 4, 6, & 8 kHz. A Kamplex AC4 audiometer was used with TDH-49P headphones.

(b) Tympanogram

Tympanometry was carried out with a Grason-Statler 1723 tympanometer. Meatal pressure was varied between +/- 200mm H₂O. From this, the middle ear pressure and maximum compliance were measured.

¹The 'loose' method of scoring requires only that the root of the key-word be reported correctly, tense and singular/plural do not matter (Bamford & Wilson, 1979).

(c) Frequency Resolution (PTC)

Frequency resolution ability was measured in the form of a 3-point approximation to the psychophysical tuning curve - the PTC (Lutman & Wood, 1985). A probe tone is presented in the presence of one of three narrow-band maskers, one on-frequency and two off-frequency. Differences between masker levels for on- and off-frequency masking are calculated to approximate a measure of the lower and upper slopes of the PTC. A large difference in masked threshold between on- and off-frequency maskers denotes good frequency resolution.

Equipment

Figure 2.2 shows the experimental setup. The equipment was calibrated at the start of each experimental session using a voltmeter. Filter shapes were checked on a spectrum analyser. Stimulus presentation was controlled via a Z-2 micro-computer, output was through TDH-49P headphones.

Stimuli

The probe tone of 2kHz was generated by a Hewlett-Packard 3325A tone generator. Its level was fixed during the procedure at 10dB above threshold. Tone duration was 400ms, with a rise-fall time of 20ms. It was gated on 50ms after the start of the masker. Maskers were 500Hz wide centered on 1600Hz, 2000Hz, and 2200Hz, generated by an IHR Noise Generator. Masker levels varied throughout the procedure (see below). Masker duration was 500ms, with a rise-fall time of 20ms. Figure 2.3(a) gives the spectral representation of the stimuli, and figure 2.3(b) gives the temporal structure of the experiment.

Figure 2.2 Experimental Setup for Measurement of the Psychoacoustic Tuning Curve

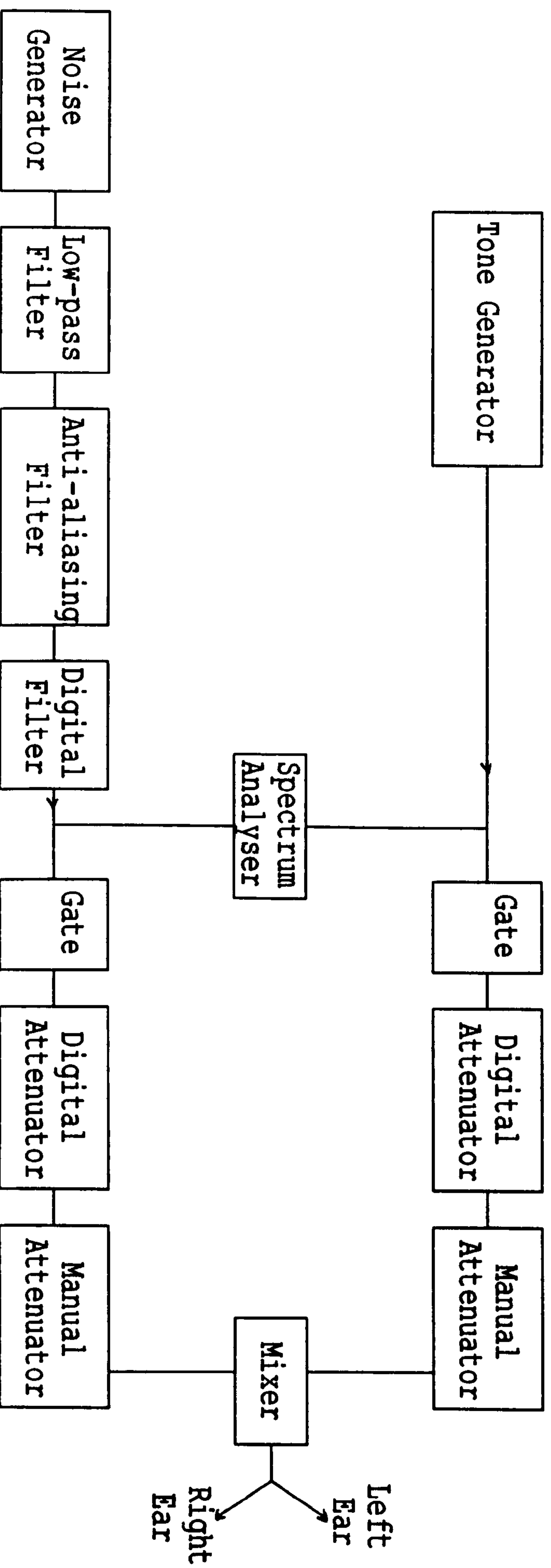

Figure 2.3(a) Spectral Representation of Stimuli for Measurement of the Psychophysical Tuning Curve

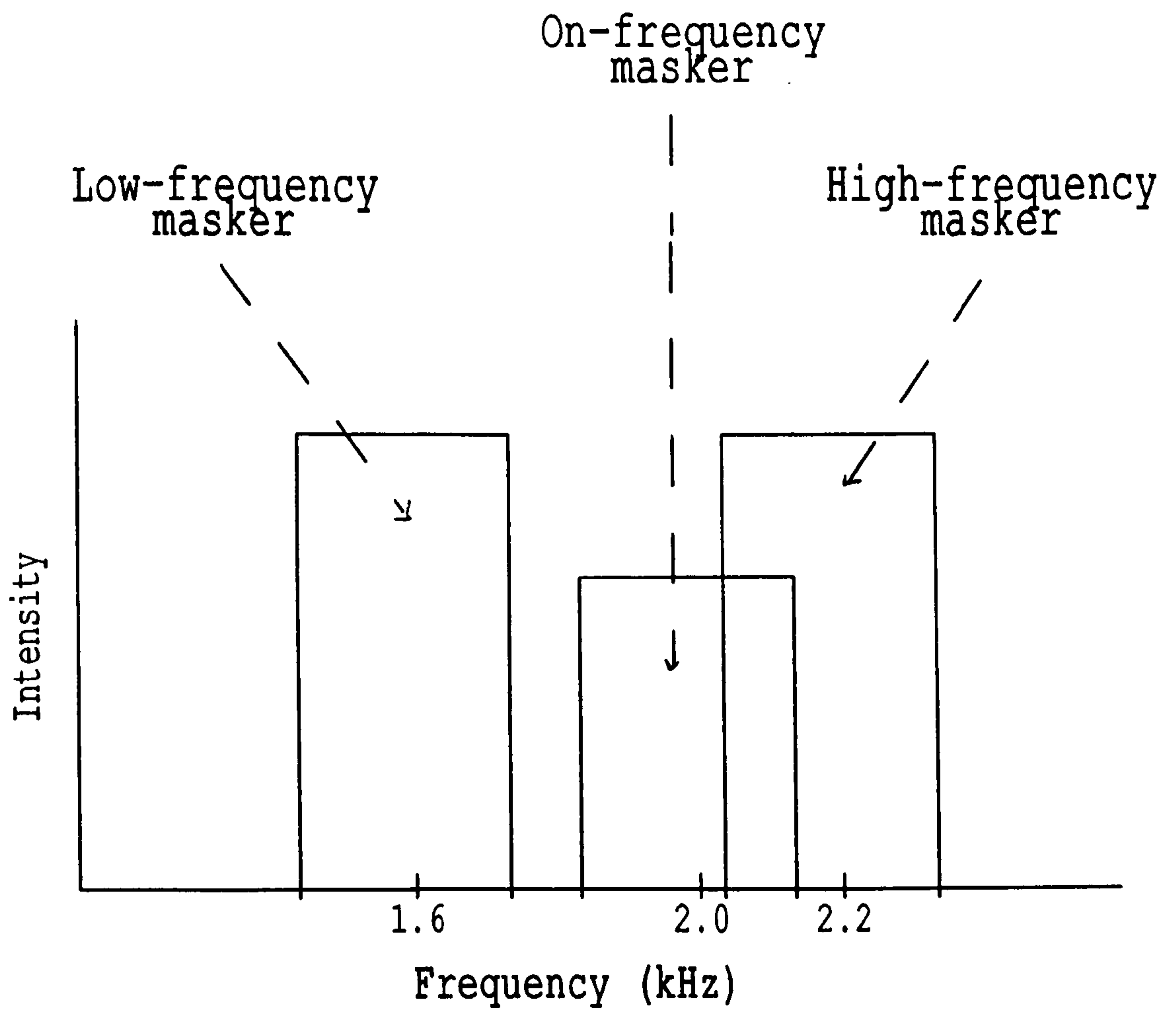
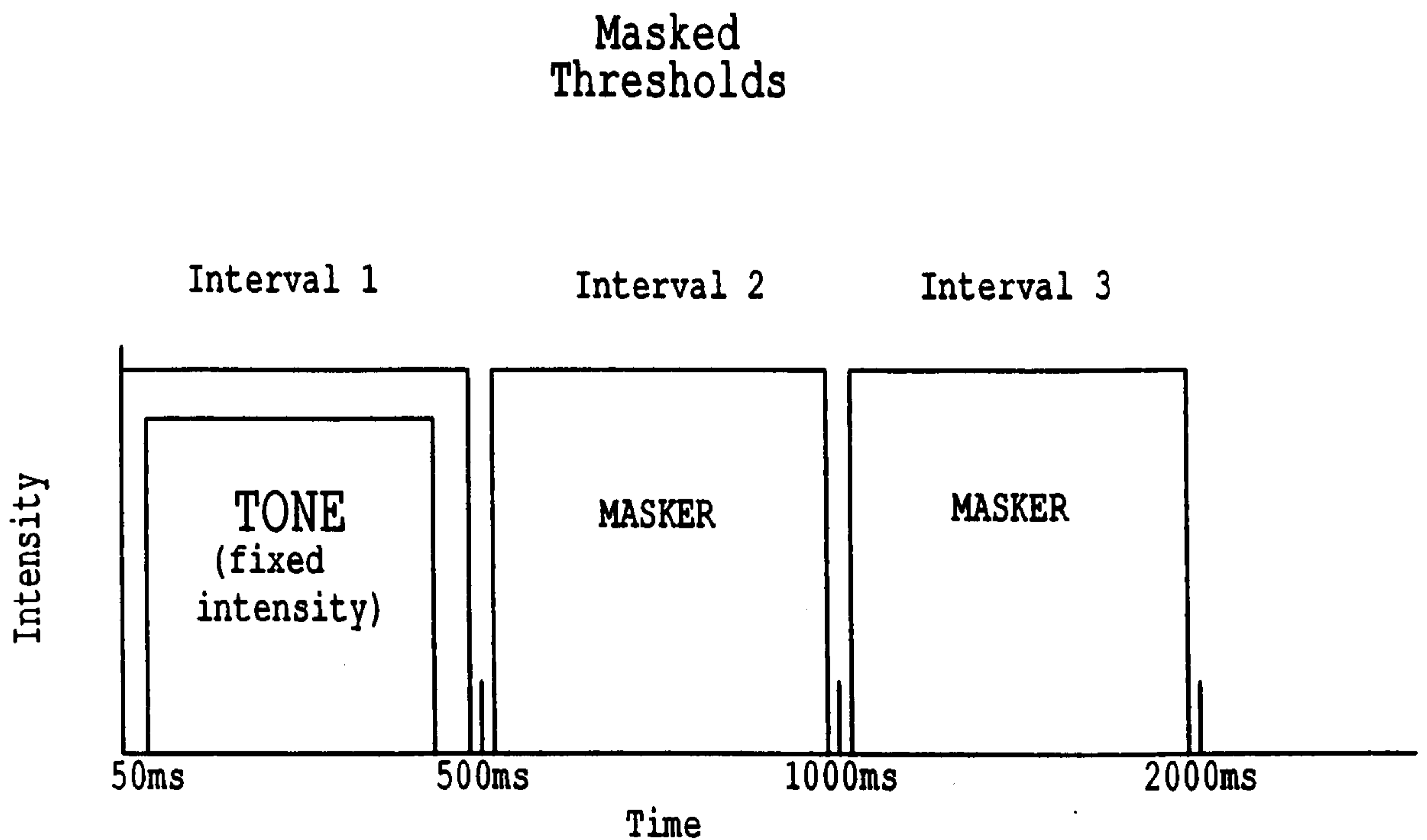
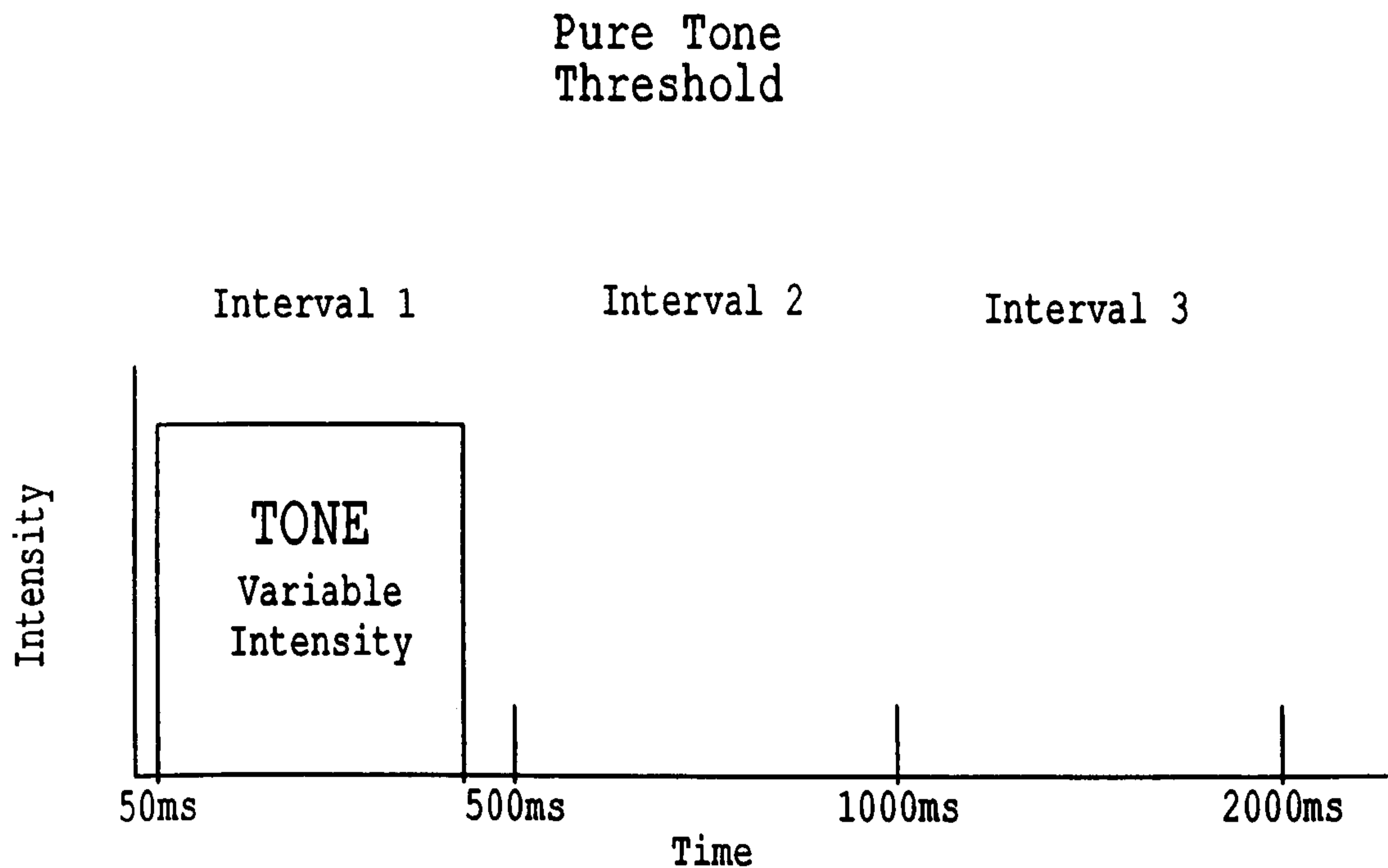

Figure 2.3(b) Temporal Representation of Stimuli for Measurement of the Psychophysical Tuning Curve



Procedure

Monaural thresholds for the probe tone and masked thresholds for the probe tone at 10dBHL were determined with an adaptive procedure, using a 3-interval forced choice (3IFC) paradigm to estimate the 79.4% correct threshold. The level of the tone was kept constant. Masker level was increased after three correct responses, and decreased after one incorrect response. Initial step-size was 8dB for the first 3 reversals, and 2dB for the remaining 4 reversals. Masked threshold was calculated by averaging the masker level at the last 4 reversals. Differences between the on-frequency and each of the two off-frequency masked thresholds were calculated to give separate measures of upward and downward spread of masking.

(d) Comparison of Forced-Choice and Clinically Determined Thresholds

Forced-choice threshold determination is more precise and criterion-free than that determined by the clinical procedure. The 2kHz threshold determined by the 3IFC method (necessary for PTC investigation) was compared with the 2kHz threshold determined by the clinical technique (in the pure-tone audiogram). This provided an opportunity to test the possibility that, for psychometric reasons alone, OADs might produce pure-tone thresholds equivalent to those of controls on a *clinical* test while actually having worse hearing, as shown by a 3IFC determination, i.e. there might be a subtle interaction between cognitive style and implementation of the clinical test procedure.

(e) Noise Immission Rating (NIR)

The NIR form is used to classify and quantify past noise exposure from three sources: occupational, social, and gunshot plus explosives.

Procedure

The form was completed in accordance with the protocol used in the UK National Study of Hearing - NSH (Davis 1983b). Individuals are questioned about the nature of the noise source(s) to which they have been exposed, duration per day over the years, and the use of ear protection for any noise they have been exposed to for long periods of time that was "loud enough to disrupt normal communication". Gunshot is quantified by size of gun-bore, the number of rounds fired and the use, or otherwise, of hearing protection. The cumulative total from each category is calculated resulting in NIR values on a 5-point scale, from 0 (no material noise exposure) to 4 (extreme noise exposure).

2.3.3.3 Central/Cognitive Tests

(a) BKB Audiovisual Test (BKBAV)

Subjects are presented with sentences audiovisually at an adverse auditory S/N ratio, so that the use of visual information is required for sentence discrimination. Overall score, therefore, reflects the ability to use and combine visual information with minimal auditory information.

Stimuli

Thirty BKB sentences were video-taped as described in McLeod and Summerfield (1987). The particular sentences used here were selected from their large corpus of reference data on the basis of displaying the largest advantages when presented audiovisually as compared to auditorily alone. Speech and white noise were recorded at a S/N ratio of -16dB. The tape was played to the subject at 60dB SL.

Procedure

The subject was seated in a sound-attenuated chamber, 1.5 meters away from a 21-inch (53cm) television screen wearing Sennheiser HB414 headphones. After each sentence was presented subjects wrote down as much as they had understood. The first 10 sentences were run as practice, the remaining 20 for the test. The sentences were scored as the number of key words (loose) correctly reported out of 60.

(b) Sentence Completion Test

The Sentence Completion Test was used to assess an individual's ability to build a sentence around a partially complete sentence frame. This test is thought to test fluency, grammatical knowledge and use of contextual information.

Stimuli

The stimuli were 20 sentence frames, 10 of 3 words, 10 of 4 words. In each sentence two of the words were represented by only an initial letter. The subject's task was to complete the missing words in order to make a grammatically correct sentence. Proper names were permitted and subjects were allowed to insert punctuation to meet grammatical constraints. For example:

B..... made T.....

could have been validly completed as:

BOB made TEA

Procedure

Subjects were instructed to complete the sentences as quickly as they could, leaving out any sentences with which they were experiencing a complete 'blockage'. They were given a time limit of 10 minutes to complete the task but were encouraged to give up if they were agonising over only 1 or 2 unfinished sentences. In order to be scored as correct the sentence simply had to make syntactic and semantic sense; the content did not have to be pragmatically likely. The number of sentences correctly completed after 2.5 minutes was noted, as was the total score and completion time (when available).

2.3.3.4 Personality-Related Tests

(a) Crown-Crisp Questionnaire

This questionnaire is designed to give a profile of psychoneurotic personality traits. It consists of six personality sub-scales with 8 questions in each, as devised by Crown & Crisp (1966). The scales are:- free-floating anxiety, phobic symptoms, obsessive symptoms, somatic anxiety symptoms, depressive symptoms and hysterical personality traits (extroverted neurosis). Appendix 2.2 contains the questionnaire.

Procedure

Subjects were asked to complete the questionnaire in relation to how they generally felt. They completed the questions in accordance with the instructions printed on the questionnaire. It was emphasised that they should answer every question, and that they should not think for too long about each.

2.4 RESULTS

Univariate analyses were carried out to test for group differences between OADs and controls on the many variables measured. It is hypothesised that OADs as a group will have poorer performance on psychoacoustic, cognitive and performance measures, while also having more extreme values on tests of personality-related factors. Analyses of variance (ANOVAs), t-tests and chi-

square analyses were carried out to look at raw group differences. Analyses of covariance (ANCOVAs) were used to investigate interrelations between certain variables. In all cases, where the results of ANCOVAs are reported covariates are statistically significant; their effects upon the group differences are also reported.

2.4.1 OAD Status

OAD status was confirmed in all patients. That is, (a) all had pure tone thresholds of less than or equal to 20dB for the average of both ears at all frequencies up to and including 4kHz, and (b) OADs as a group reported significantly greater handicap and disability than controls for hearing in a variety of circumstances (overall disability, $t=9.75$, $p<0.001$; handicap, $t=13.76$, $p<0.001$).

2.4.2 Psychoacoustic Factors

(a) Auditory Thresholds

Mean audiogram (binaural average of thresholds for all frequencies tested - AVAUDIO) and mean low-frequency audiogram (binaural average of thresholds at 250 and 500Hz - AVLOW) did not differ significantly between the groups. The OAD group did, however, have significantly worse thresholds at frequencies of 0.25 kHz and 3 kHz for averages of left and right ears and for average high-frequency audiogram (binaural average of 3, 4, and 6kHz -

AVHIGH) (see figure 2.4 and Table 2.2). Pure-tone thresholds as determined by the clinical method were significantly higher (worse) overall than those determined by the criterion-free 3IFC for both OADs and controls; OADs did not differ from controls in the size of this discrepancy. This latter result suggests that an interaction of psychophysical method with the subject's criterion for making a response is not a factor in OAD.

Table 2.2

Means, standard deviations (in brackets) and differences between OAD patients and controls in pure tone thresholds

Frequency (kHz)	Mean threshold (dBHL)		t	p
	OADs	Controls		
0.25	11.8 (6.9)	7.7 (6.1)	2.32	0.02
3.0	10.3 (7.7)	5.5 (6.8)	2.47	0.02
AVAUDIO ¹	10.9 (6.8)	7.9 (4.8)	1.81	0.08
AVHIGH ²	13.8 (8.4)	9.2 (6.7)	2.68	0.01
AVLOW ³	9.8 (6.7)	7.5 (5.4)	1.60	0.11

¹ Mean thresholds for both ears at 0.25, 0.5, 1, 2, 3, 4, 6 & 8kHz.

² Mean thresholds for both ears at 3, 4 & 6kHz

³ Mean thresholds for both ears at 250 & 500 Hz

Figure 2.4 Average Audiograms of OADs and Matched Controls

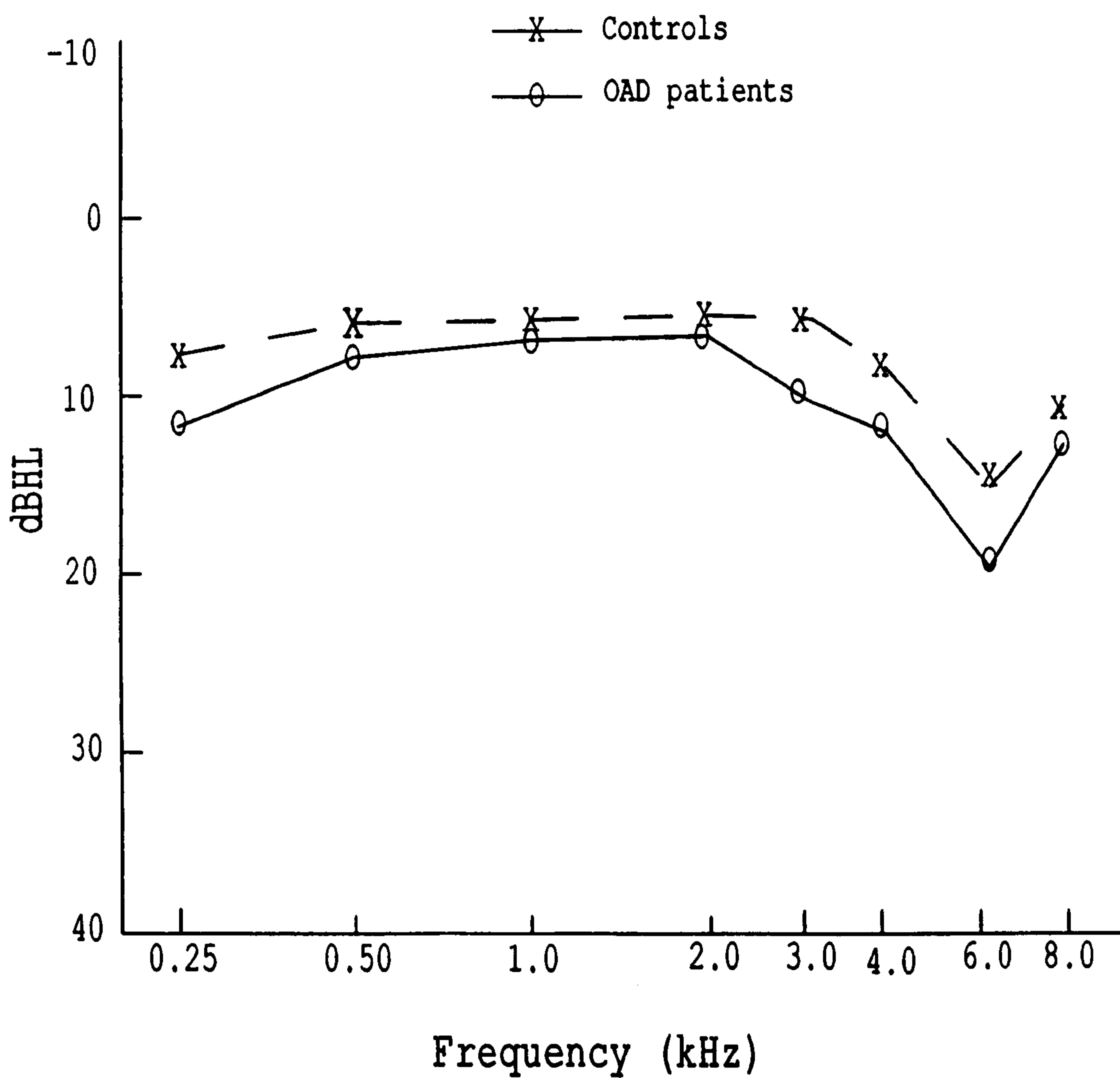

(b) Tympanometry

All OADs were found to have normal middle ear pressure and compliance. No further analyses were done with these parameters.

(c) Frequency Resolution

Somewhat surprisingly, no differences were found between OADs and controls on any parameter measured for the PTC, i.e on- and off-frequency masked thresholds, the computed values corresponding to upward and downward spread of masking, or the difference between masked and non-masked on-frequency threshold.

2.4.3 Performance Tests

(a) PFFIN Test

OADs performed more poorly on the PFFIN test ($t=-2.43$; $p<0.02$) than controls. Group differences were considerably diminished when AVAUDIO, or AVHIGH, or AVLOW were taken account with ANCOVA (columns 2 & 3 table 2.3). This occurred even though, in the cases of AVAUDIO and AVLOW, the group differences in the raw covariates were not statistically significant.

(b) BKBAV Test

OADs also performed more poorly than controls on the BKBAV audiovisual test ($t=-2.30$; $p<0.05$). Again, AVAUDIO, AVHIGH and AVLOW diminished group differences when taken into account with ANCOVA (columns 3 & 4 table 2.3).

Comparison of the effects on the PFFIN and BKBAV group differences for ANCOVA with pure tone thresholds shows that group differences in PFFIN score are diminished more than group differences in BKBAV score. However, the expectation that hearing levels at different frequency regions would differentially affect these two tests was not confirmed (Table 2.3). There was a significant correlation between performance on these two disability tests among the OADs ($r=0.69$; $p<0.001$); this remained significant when partialling for age, hearing level and linguistic ability. It indicates that there is a dimension of variation in disability within the OAD group, i.e some patients perform consistently better than others. Such a correlation was not present among the control group. This suggests that it might be necessary and useful to distinguish those OADs with measurable performance disability from those without.

Table 2.3

Differences in percent-correct on the PFFIN and BKBAV tests between patients and controls before and after partialling for various auditory thresholds. Mean difference favours controls over OADs

Partialled Variable	PFFIN mean diff	P-value	BKBAV mean diff	P-value
None (raw)	+5.8	0.02	+12.9	0.03
AVAUDIO ¹	+3.7	0.11	+11.3	0.06
AVHIGH ²	+4.3	0.08	+11.6	0.05
AVLOW ³	+4.3	0.08	+12.0	0.04

¹ Mean thresholds for both ears at 0.25, 0.5, 1, 2, 3, 4, 6 & 8kHz

² Mean thresholds for both ears at 3, 4 & 6kHz

³ Mean thresholds for both ears at 0.25 & 0.5kHz

2.4.4 Central/Cognitive Tests - Sentence Completion Test

OADs performed slightly less well than controls on the sentence completion task, in that they had acceptably completed fewer sentences after 2.5 minutes than had controls (mean score at 2.5 minutes: OADs 38.9%, Controls 46.6%). However, this difference was only on the margin of significance ($t=-1.82$, $p<0.07$). As a covariate, sentence completion is non-significant when used to account for group differences on the two performance tests (PFFIN and BKBAV), although it does diminish the group differences in performance (final p-value after taking sentence completion into account with ANCOVA - PFFIN: $p<0.08$; BKBAV: $p<0.13$).

2.4.5 Personality-Related Tests - Crown-Crisp Questionnaire

OADs were found to be more anxious than controls in their levels of free-floating anxiety and phobic anxiety ($t=1.78$, $p<0.08$; $t=2.56$, $p<0.01$), and consequently on an equally-weighted combined scale of free-floating, phobic and somatic anxiety ($t=2.21$, $p<0.03$). This combined scale of the three forms of anxiety did not significantly alter group differences in performance on either performance test (PFFIN or BKBAV). This indicates that the personality differences between the groups are largely independent of the performance differences. Thus individuals might qualify for OAD status on performance grounds or personality-related grounds, or both. Anxiety level was positively correlated with BKBAV score within the patient group ($r=0.39$; $p=0.05$), though not among the controls. When overall otological history was used as a covariate, the group differences in anxiety level were completely removed. Thus among this sample and its controls, differences in otological history (or at least in the tendency to remember and report symptoms) are so closely tied to anxiety that it is impossible to separate out their role.

2.4.6 Otological History

More patients than controls complained of experiencing tinnitus and of suffering from earache as an adult ($X^2=7.21$, $p<0.007$; $X^2=8.93$, $p<0.003$ respectively). In addition, there was a greater reported prevalence of ear disorder among the families of OADs than among the families of controls ($X^2=5.74$, $p<0.017$). Hence, the

combined variable of overall otological history is also significantly higher among the patient group than among the controls ($X^2=11.40$, $p<0.002$).

2.4.7 Reported Disability and Handicap - IHR Hearing Questionnaire

As noted in (1) above, OADs reported significantly greater disability and handicap than did controls. These group differences in self-reported handicap and disability were not diminished when anxiety level, performance disability, hearing levels and otological history were taken into account, either independently or combined, in an ANCOVA. Self-rated disability was significantly correlated with anxiety level among the OAD group ($r=0.64$, $p=0.002$), but not among the controls.

2.5 DISCUSSION

2.5.1 Determinants of OAD Status

OADs performed less well than controls on the two disability tests (PFFIN and BKBAV). This presumably contributes to the patients' self-reported handicap and disability. However, this true performance deficit does not completely explain patients' reported disability/handicap, as is shown by the fact that group differences in reported disability/handicap were not diminished when PFFIN score was incorporated as a covariate.

2.5.2 Psychoacoustic Factors

(a) Pure Tone Thresholds

By definition and by selection, OAD patients have audiograms within 'normal' limits. They do, however, have on average slightly worse thresholds than controls at all frequencies, and significantly worse thresholds at frequencies of 250Hz and 3KHz. These two significantly differing frequencies are not usually tested during a routine clinical audiogram. It is not likely that these non-standard frequencies have particular weight in determining self-rated and/or performance disability, but the finding does show that some patients have worse hearing than others within the 'normal' range. Inclusion in the study is based on 'normal hearing' at a subset of frequencies. Some patients therefore qualified who would not have done so had other frequencies been used to decide inclusion. This type of selection artifact is unavoidable in any study where a cut-off is imposed upon a subset of variables. The finding implies that during stage II, thresholds for all frequencies should be measured.

(b) Frequency Resolution

It is surprising that there were no group differences in frequency-resolving ability in view of past work relating speech discrimination to frequency resolution (Tyler et al, 1982a; Lyregaard, 1982) and in view of the specific findings of Pick & Evans (1983) and Narula & Mason (1988). The controls in the latter study, however, were all young, unlike the patients themselves, and the abnormalities of shape obtained included abnormalities

additional to a loss of tuning. This null finding at 2kHz does not rule out abnormalities of frequency resolution in OAD, possibly the use of an alternative measure or measurement at a different frequency might have given results more in line with past work. This finding was borne in mind when choosing the psychoacoustic tests for stage II. More important than this null finding, however, are the many positive results which clearly demonstrate that frequency resolution can only be one component of the OAD syndrome.

2.5.3 Performance Factors

The demonstration of a performance deficit among the OAD group on both the PFFIN and BKBAV tests shows that the syndrome is not purely personality-related, and that at least some patients have a measurable basis for their complaints. This implies that present audiometric and other clinical assessments, (such as those used by Pick & Evans, 1983; Earl et al, 1987; Narula & Mason, 1988 with their OAD-like patients) are not sufficiently sensitive to minor, but genuine, performance deficits. Group differences in PFFIN and BKBAV scores were reduced, although not completely removed, when hearing levels were taken into account with ANCOVA. This finding shows that auditory factors, shown here as reduced sensitivity, contribute some of the performance disability in OAD. However, the psychoacoustic factors measured here did not entirely explain this performance deficit. It suggests that other psychoacoustic abilities should be measured in stage II of the study.

Although patients performed less well than controls on the BKBAV it is unlikely that a lipreading deficit is the major reason for this, for two reasons. First, if lipreading ability were the main explanation for performance on the BKBAV test one would have expected no diminution in group differences when incorporating high-frequency sensitivity as a covariate, but a large diminution in group difference when incorporating low-frequency sensitivity. This expectation arises because high-frequency auditory information is facially visible; hence the auditory information becomes redundant. On the other hand, low-frequency information is not facially visible; hence the auditory information becomes valuable (Summerfield, 1987). The results here showed no differences when incorporating high- or low-frequency sensitivity as a covariate. This is probably in part because the group difference in AVLOW is not statistically significant. However, this cannot be the only reason, since as a covariate of the performance tests AVLOW is significant. Second, the scores on the PFFIN and BKBAV tests were highly correlated within the OAD group, implying that there are common factors determining the patients' performance upon them. Linguistic ability is one factor they have in common, since the group differences in performance are diminished, although not completely removed, when sentence completion score is taken into account as a covariate. Linguistic skill possibly acts upon performance ability by enabling the use of top-down processing when bottom-up processing is insufficient, such as in the presence of background noise (This is discussed further in section 3.3.4.3(b).) During stage II, then, it is necessary to use a measure of lipreading that can differentiate between a general performance deficit influenced by linguistic skill, and a pure

measure of lipreading ability, not confounded by other factors.

2.5.4 Personality-Related Factors

OADs were found to be slightly more anxious than controls, although actual performance was independent of anxiety. It would therefore seem that anxiety influences OAD status by enhancing patients' concern about their general health or specifically about otologically-related factors (see 2.5, below); anxiety may hence have prompted the seeking of medical investigation. Surprisingly, anxiety level is positively correlated with performance on the BKBAV test within the patient group. This probably reflects general arousal and motivation during the test, rather than an effect of anxiety on audiovisual ability *per se*.

2.5.5 Otological History

A history of past otological disorder plays a role in differentiating the two groups, with OAD patients having a higher incidence of current and past disorder. This probably acts to increase the likelihood of seeking medical advice for a given level of current symptoms. However, when otological history is taken into account with ANCOVA, group differences in anxiety level are removed. There are at least three possible interpretations of this finding: first, that anxiety enhances a patient's awareness of his or her hearing and any possible dysfunction of it. Second, that the report

of a history of otological (or any other) problems is made more likely by an anxious personality. (Independently confirmed histories were not a practical possibility, so there is no good evidence for this). Third, that the patient's anxiety influences the strength with which symptoms are described, which then increases the likelihood of referral by the general physician. Although it cannot be conclusively demonstrated here, the first of these possibilities is the more likely, particularly in the light of past research (Gochman & Saucier, 1982) showing that anxiety influences an individual's perceived vulnerability to illness. These interpretations in terms of anxiety and history may contribute to the presence of OAD patients in the clinic, but cannot be associated with their actual performance deficit.

2.6 SUMMARY AND CONCLUSIONS

In summary, OAD patients as a group have a degree of performance disability, which can in part be explained by a combination of minor auditory dysfunction (here showing as slightly elevated pure-tone thresholds) and poor linguistic ability. This performance deficit alone is too small to explain the high level of disability and handicap reported by OAD patients. Self-reported disability is determined by anxiety level. Anxiety level and overall history of otological disorder are also inter-related. Hence, a history of otological disorder in conjunction with an anxious personality type partly explains the presentation of OAD patients at the clinic.

These findings show that as hypothesised at the start, OAD is a complex multifactorial problem, with no single underlying characterising factor. Figure 2.5 summarises the relationships and their interactions as described in the text above. The solid lines depict relationships demonstrated by this study; the broken lines depict relationships that remain hypothetical.

2.7 IMPLICATIONS FOR STAGE II

The many positive findings from this small study of twenty patients demonstrate that the test battery approach is useful for investigating the OAD syndrome, and that a similar approach should be taken in stage II. The finding that as a group OAD patients do have a performance deficit implies that it would be valuable to investigate other factors that potentially influence speech discrimination in noise, such as temporal resolution and selective attention skills. Also in stage II a different measure of frequency resolution should be incorporated in the test battery, since past work has shown frequency resolution to be relevant to OAD, as should a measure of lipreading that is not confounded by linguistic factors.

Figure 2.5 Relationships between Factors Shown to Influence OAD Status

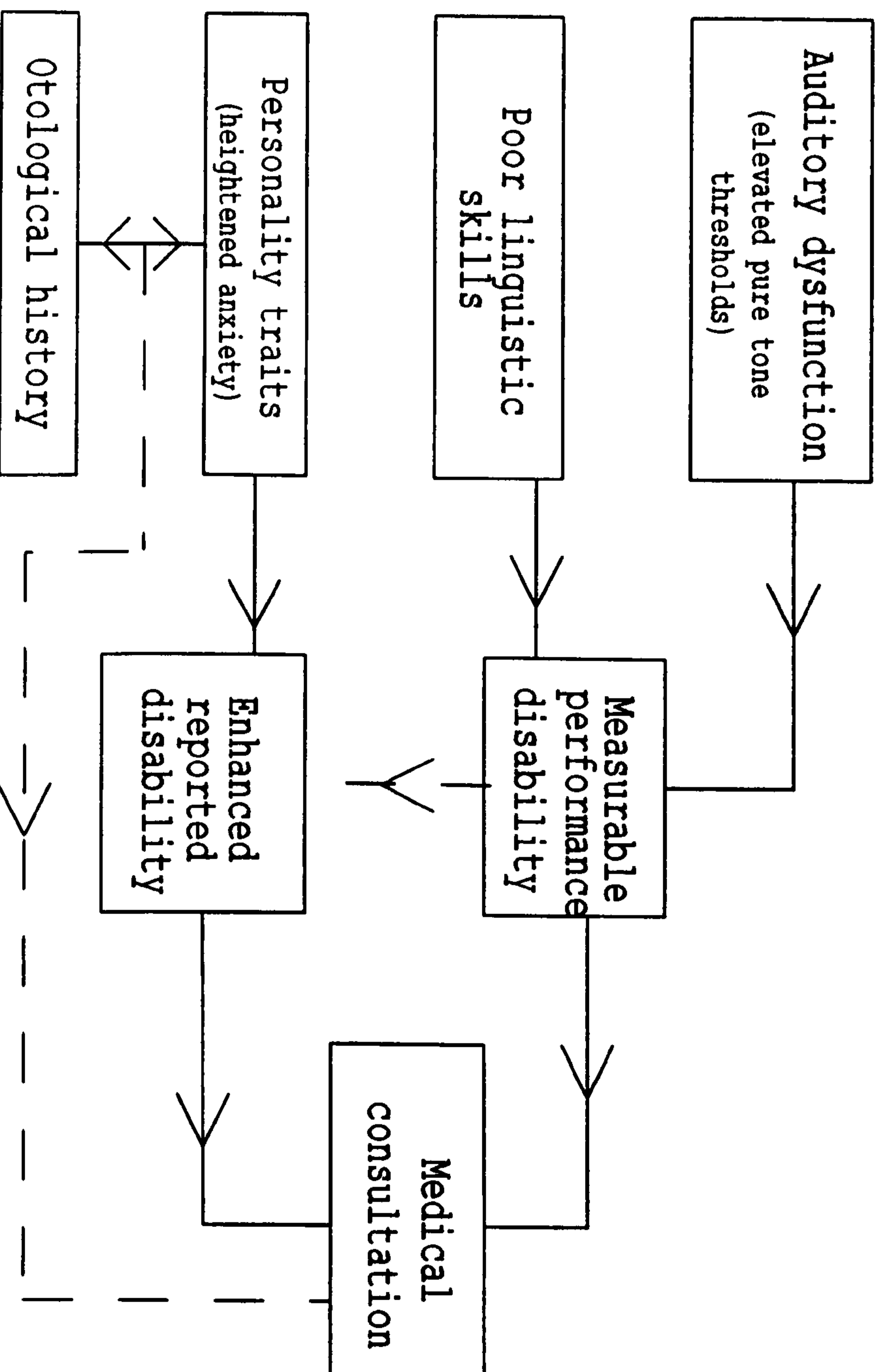

CHAPTER 3

3.1 INTRODUCTION

This chapter describes the methodology and results of stage II of the OAD study. It includes further evidence to support the multifactorial model suggested by stage I, and the data from which the clinical test package was devised. The number of parameters measured requires that the results section is necessarily detailed and long. The clinical or general reader might, therefore, find it profitable to read only sections 3.5.1 and 3.5.2.1 of the results section and then proceed to later chapters.

Stage I of the project demonstrated that the OAD syndrome is multifactorial, and gave a general impression of the important factors, but the subject numbers were too small to quantify their relative importance. The aim of stage II was to test a larger number of subjects so that the relative importance of each factor could be quantified, and to test additional factors, potentially important in OAD. The test battery of stage II was structured in the same general way as that for stage I. The findings from stage I were used to determine which tests were added, omitted or improved. In the following section I describe in detail the rationale with which the stage II tests were chosen. They are listed in Table 3.1 in the 'methods' section.

3.2 DETERMINATION OF THE STAGE II TEST BATTERY

3.2.1 Psychoacoustic Measures

In stage I OAD patients were found to have a measurable performance deficit that was not entirely due to pure tone sensitivity nor frequency resolution (as measured by the PTC). This justified inclusion of different psychoacoustic tests to those investigated in Stage 1. These tests are discussed below.

(a) Frequency Resolution

Past research, reviewed in chapters 1 and 2, highlights the importance of frequency resolution for discrimination of speech-in-noise. It was therefore surprising to find that OAD patients as a group did not differ from controls in the shape of their PTC, and hence, in their frequency-resolving abilities. However, the shape of the auditory filter derived from the PTC technique is confounded by two factors. First, the technique does not well differentiate between the frequency selectivity of an individual's auditory system and the 'internal noise' or 'processing efficiency' of that system. The PTC technique assumes that the general processing efficiency of the auditory system is fixed for all frequencies and signal levels, and that it can be corrected for by adding a constant to all masked thresholds, whether they arise from on- or off-frequency maskers. However, if the processing efficiency were in part peripheral, processing efficiency might differ between on- and off-frequency conditions. These differences are not accounted for in the measurement of a PTC.

The second confounding factor is that of off-frequency listening (Patterson, 1976). During processing of a signal in noise it is assumed that the subject listens to the output of the auditory filter giving the best S/N ratio. Under most conditions this will be the filter centered at the signal frequency. However, due to the shape of the auditory filter, the S/N ratio output may be higher at filters not centered on the signal frequency for certain shaped maskers. Performance will be improved by listening through these off-frequency filters, by the process known as off-frequency listening. Patterson (1976) devised a technique for measuring frequency resolution that restricts off-frequency listening by masking above and below the centre frequency. It is known as the "notched-noise technique". The width of an auditory filter is estimated by determining the masked threshold of a signal of interest, in the presence of a masker with a notch of varying width centered at this frequency. The technique works on the principle that a high level of signal is required when the notch is narrow, since almost all the noise will pass through the auditory filter; however, as the width of the notch is increased, signal threshold decreases, because less noise passes through the filter located at the signal frequency. By differencing thresholds for maskers containing notches of differing bandwidths, a measure of frequency resolving ability is obtained. This differencing technique distinguishes between the frequency selectivity and the processing efficiency of the auditory system. Patterson et al (1982) report that a one-point estimate of filter width can be made with this technique. It requires measurement of just two thresholds, one in the presence of a masker with no notch, the other in the presence of a masker with a notch that must be narrower than a 'normal' auditory filter.

The difference in masked thresholds for the notch and no-notch noise maskers are greater for narrower auditory filters than for wider ones. Figure 3.1 gives a diagrammatic representation of this. Patterson et al showed that this one-point estimation is sensitive, reliable and quick. This test was used in preference to the PTC to measure frequency resolution.

(b) Temporal Resolution

An individual requires the ability to analyse rapid changes in a waveform in order to distinguish different speech sounds, and hence to process speech successfully. This analysis is known as temporal resolution. Good temporal resolution ability is especially important for the processing of speech in noise, for which it is necessary to distinguish between the temporal ordering of the speech and noise signals. Temporal resolution ability can be assessed with a variety of methods (see Moore, 1985 for review), measurement of gap detection thresholds is the most straight forward of them. The subject is presented with at least two long-duration signals, one of which has in it a short silent interval, or temporal gap; this signal must be identified by the subject. The gap detection threshold is defined as the shortest duration gap the subject can identify. It is unclear exactly where within the auditory system temporal resolution takes place. Work with normally-hearing listeners suggests it is a peripheral process, as seen from the finding that gap thresholds vary with the centre frequency of the signal. The threshold becomes longer as frequency decreases (e.g. Shailer & Moore, 1983). This is thought to be due to the temporal response of the auditory filters. At low frequencies, where auditory filters are

Figure 3.1 Diagrammatic Representation
of the additional Masking due to
Widened Auditory Filters

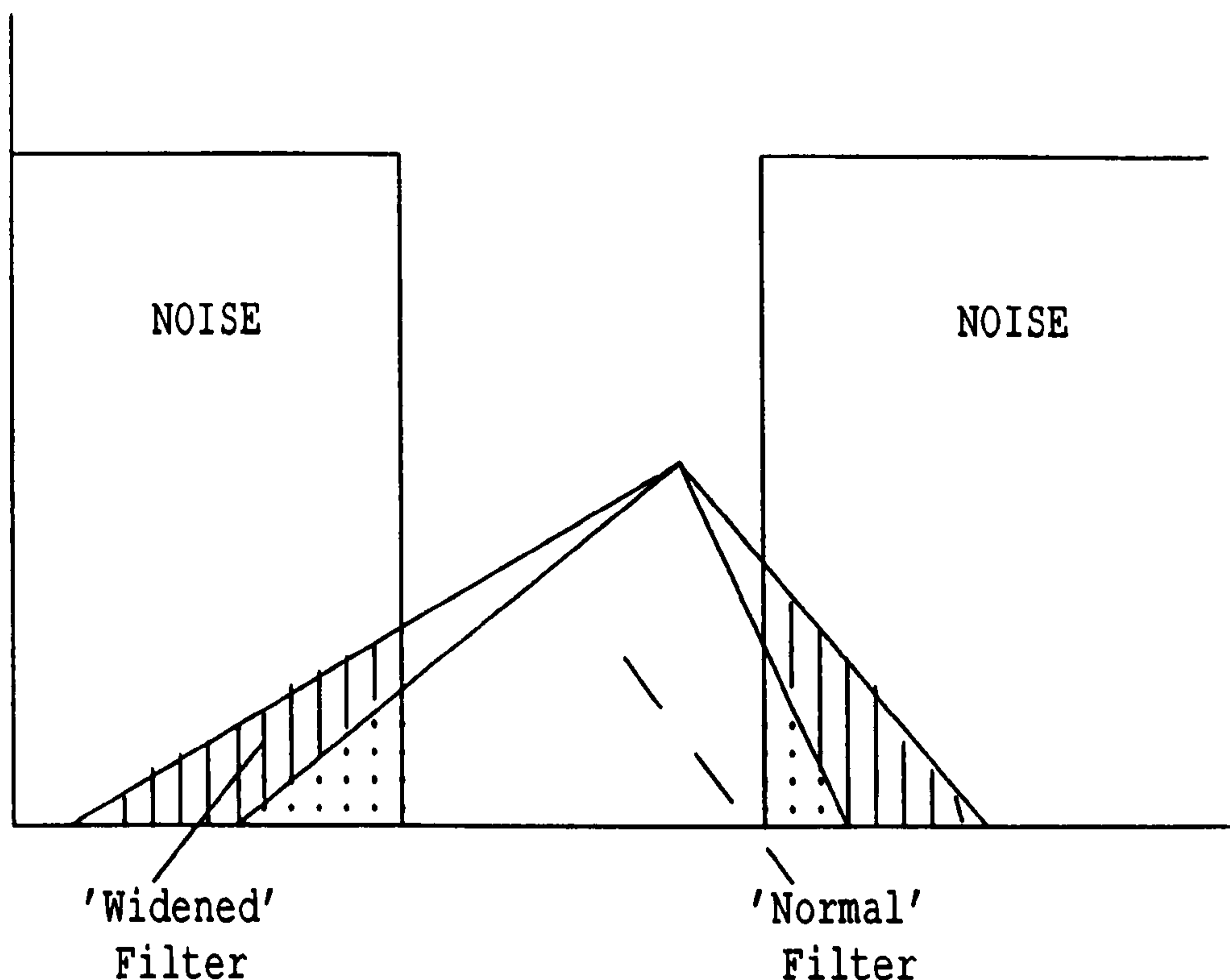

Dotted region depicts masking that would occur with an auditory filter of 'normal' width

Vertical shading depicts the additional masking that would occur with a 'widened' auditory filter

comparatively narrow, the signal continues to 'ring' in the auditory filter after the signal has ceased; this ringing partially fills in the brief gap. At higher frequencies, where the auditory filters are comparatively wide, there is less ringing after the signal offset, and so gap thresholds are shorter. Work with the hearing-impaired, however, suggests central influences on temporal resolution, as follows. First, temporal resolution in sensorineurally-impaired listeners is worse than in normally-hearing listeners (Fitzgibbons & Wightman, 1982; Tyler et al, 1982b). If temporal resolution were of purely peripheral origin these listeners might be expected to have better than normal temporal resolution, mediated through their widened auditory filters. Second, individuals with cerebral injury (Lackner & Teuber, 1973) and lobectomised patients (Efron et al, 1983) show reduced temporal resolution in the presence of normal thresholds, as do individuals with retrocochlear losses (Zwicker & Schorn, 1982). Moore (1985) suggests that temporal resolution is probably associated with centrally-based function, and that in sensorineural listeners this impairment is sufficient to outweigh any improvement that might have resulted from a broadening of the auditory filters. Studies of the relationship between temporal resolution and speech-in-noise comprehension are somewhat equivocal. Tyler et al (1982b) showed high correlations between gap detection and speech perception in noise, even after the effects of pure tone sensitivity had been removed. Tompkinson (1985) found gap detection at 4kHz to correlate with speech discrimination ability, but once high-frequency sensitivity had been taken into account this relationship disappeared. On the other hand, Festen & Plomp (1983) found no correlation between temporal resolution and speech perception, nor did Lutman & Clark (1986).

Nevertheless, it was decided to measure frequency resolution ability in stage II as a possible explanation for the measurable disability of OAD patients.

(c) Binaural Hearing

In stage I OADs performed more poorly than controls on the PFFIN test, but the psychoacoustic factors measured were unable to fully explain the deficit. The special recording of the test (see section 2.3.3.1(c)) means that binaural cues are necessary for good performance. A possible explanation for patients' poor performance, therefore, might be a deficit in these skills. This could explain why the studies by Pick & Evans (1983, Earl et al (1987) and Narula & Mason (1988) failed to find a performance deficit for speech-in-noise among their OAD-like patients. Binaural hearing cues are used mainly for sound localisation. This is particularly important for the processing of speech in noise, which requires the ability to distinguish between the signal source and the noise source by locating their respective positions in space. This is done by comparing information arriving at the two ears, i.e by binaurally differentiating and integrating the different aspects of the sound. Two types of information are used for this: (1) the difference in the time of arrival of the sound at each ear, and (2) the difference in intensity of the sound at each ear. Stevens & Newman (1936) were the first to fully separate these two mechanisms, by showing that one operates at high frequencies and one at low. Sandel et al (1955) confirmed that intensity differences are the cues used to locate high frequency sounds, while phase differences are used to locate low frequency sounds. These findings have since been reproduced (e.g. Yost et al, 1971).

A second phenomenon of binaural hearing, partly related to localisation abilities, is that of the binaural masking level difference (BMLD). It reflects a process by which interaural time and intensity differences, as mentioned above, are used to extract a signal from noise. The phenomenon was first reported by Hirsh (1948) and Licklider (1948). The BMLD is a measure of an improvement in detectability of a signal which can occur under specific binaural listening conditions. (A non-BMLD improvement in detection arises by summation when identical signal and noise are presented to the two ears). Although there are other conditions that generate BMLDs, the BMLD is most generally defined as the difference in threshold of the signal for the case where the signal and masker have the same phase and level relationships at the two ears, and the case where the interaural phase relationships of the signal and masker are reversed (Moore, 1977). Research shows that BMLDs are smaller than normal in cochlea-impaired listeners (Hall et al, 1984; Quaranta & Cervellera, 1974), in patients with Meniere's disease and in eighth nerve tumour groups (Olsen et al, 1976), and in aphasic children (Rosenthal & Wohlert, 1973). In order to study binaural processing abilities BMLDs were measured in stage II.

(d) Evoked Otoacoustic Emissions (EOEs)

Kemp (1978) demonstrated that acoustic signals, thought to originate in the cochlea, could be recorded from the ear canal. He referred to them as 'acoustic emissions'. Three major types of emission have been measured: (1) spontaneous emissions that occur without external stimulation, (2) distortion product emissions that occur after stimulation with two continuous tones of similar

frequency, f_1 and f_2 . (the emitted sound is at intermodulation frequencies, such as f_1+f_2 , or $2f_1-f_2$); and (3) evoked emissions, after stimulation by a click or tone burst. It has been shown that emissions cannot be evoked from ears with hearing impairments of greater than about 20dBHL (Kemp, 1986; Probst et al, 1987; Lutman & Fleming, 1988). (For further information see the review by Cope & Lutman (1988).) Since evoked otoacoustic emissions seem to be a sensitive indicator of mild cochlea impairment they were measured in stage II of this study.

(e) Diminished Pure Tone Sensitivity at 'Unconventional' Frequencies

In stage I OAD patients were found to have significantly poorer pure tone sensitivity at frequencies of 3 & 6kHz, these frequencies are not conventionally tested in the clinic. These frequencies, plus others not conventionally tested (125, 750 & 1500Hz) were measured during stage II.

3.2.2 Cognitive/Central Measures

(a) Lipreading Test

In stage I OADs performed more poorly than controls on a test of audiovisual ability. However, even after analyses of covariance, it was not possible to be certain whether this performance deficit was due to poor lipreading ability *per se*, or whether it was due to a more general performance deficit, probably influenced by a combination

of auditory, visual and linguistic factors. OADs also were marginally poorer at the test of linguistic processing than controls. It is necessary, then, to assess lipreading ability independently of linguistic ability. McLeod & Summerfield (1987) postulate a 3-stage model of audiovisual speech perception, involving auditory analysis, visual analysis and linguistic analysis. The model postulates that during audiovisual perception, visual and auditory analyses proceed independently of each other, but that linguistic processing ability is involved in both. A true measure of visual benefit during audiovisual presentation requires that the confounding effects of linguistic ability on auditory and visual analysis are removed. McLeod (1988) devised an audiovisual test that fulfills this requirement, in which speech reception thresholds in noise (SRTNs) are measured under auditory-alone and audiovisual presentation. The improvement in performance during the audiovisual presentation over auditory-alone presentation gives a measure of visual benefit that is not confounded by linguistic ability. This test was therefore used in place of the BKBAV to investigate the hypothesis that OAD patients are poorer lipreaders than controls.

(b) Linguistic Processing

OADs performed more poorly than controls on the sentence completion test in stage I. This test measured ability to generate whole sentences from sentence frames. Various factors, such as vocabulary size, syntactic ability, use of contextual clues and power of imagination could all have influenced scores on this test. In stage II it was decided to investigate just one of these factors - the

use of linguistic context. The rationale behind this was as follows. There are two components to language processing, top-down and bottom-up. In bottom-up processing, the listener analyses the constituents of a sentence in the order of their acoustic input and hence, relies mainly on the acoustic content of the speech. In top-down analysis the listener accesses additional linguistic knowledge to constrain, and even potentially determine, what has been said. Final decisions about the content of the speech are not necessarily made in the order of input of its elements. The listener uses at least three levels of information concurrently to arrive at the content of the speech: syntactic constraint, semantic constraint, and a hierarchy of its likely content, given a knowledge of the topic/social situation etc. Past research has demonstrated that contextual information is used during speech processing. First, Tyler & Wessels (1983, 1985), using a gating paradigm, showed that the isolation point of a word (the point at which the word is correctly identified) comes sooner as semantic and syntactic constraints become greater. They also found that semantic constraints influence the isolation point more than do syntactic constraints. Secondly, using a sentence-shadowing technique, Marslen-Wilson (1973, 1975) showed that close shadowers (who are able to shadow a spoken sentence at a latency of just 250ms - a lag of approximately one syllable) can shadow a passage of normal prose significantly more quickly than when the sentence is semantically uninterpretable. They found shadowing latency was increased further still when the passage was both syntactically and semantically uninterpretable. In addition they found that mistakes made during shadowing of normal prose were, in 98% of cases, substitutions with a word both semantically and syntactically congruous with the prior input. In other

words it appeared that the subject was using prior context to help in responding. Thirdly, the use of context has been shown during sentence monitoring experiments (Marslen-Wilson & Tyler, 1975, 1980), during which the subject's task is to monitor a sentence for a specified word, or category of word, and then to respond to that word as quickly as possible. Marslen-Wilson & Tyler showed that monitoring time decreases as contextual constraints upon the sentence and upon the target word are increased.

The relative importance of top-down analysis in speech processing increases as the acoustic signal becomes less well defined. Miller et al (1984) and Garnes & Bond (1976) demonstrated this by altering the voice-onset-times (VOTs) of the stop-consonants of pairs of words. Under some conditions the words were acoustically very dissimilar, while under other conditions the words were acoustically very similar and hence, ambiguous. They each showed that when the acoustic signal was unambiguous (i.e the VOT was at extremes of length) the surrounding sentence did not affect word identification, but when the word became ambiguous, due to an intermediate length of VOT, the surrounding sentence did affect word identification.

In order to investigate the possibility that OADs are poorer than average at using contextual information for language processing a sentence monitoring task replaced the sentence-completion test of stage 1.

(c) Dichotic Listening Test

The term dichotic refers to the simultaneous presentation of two different auditory signals, one to each ear of the listener. The test procedure usually measures performance under one of three conditions: (1) report of right ear input only, (2) report of left ear input only or (3) report of input to both ears. The former tasks require an ability to selectively attend to one stimulus, the latter task requires an ability to divide attention efficiently between two stimuli. Both tasks also require perceptual skills, memory and binaural separation abilities, with performance on the divided condition also limited by overall processing capacity of the system (Kahneman, 1973). Right-handed individuals (and some left-handed individuals) are usually found to perform better with the right ear than with the left on language-based dichotic listening tasks (e.g. Kimura, 1961). This right ear advantage is thought to arise because the left hemisphere of the brain, with a direct dominant pathway to the right ear, is specialised for linguistic processing (see Springer & Deutsch, 1985 for review). As pointed out by Repp (1977), however, right ear advantages for the processing of language are dependent on the material and task employed. It is only during particularly difficult tasks, and tasks with interaural competition that strong right ear advantages emerge (Darwin & Baddeley, 1974).

Dichotic listening ability might reveal a minor linguistic disorder in OAD patients in one or both of the following ways. Firstly, overall performance might suffer in a language-disordered individual once the task becomes taxing (as in the divided attention condition), because of the limited capacity of the central processing system. This implies that when a task requires more processing

capacity in terms of effort than that available, performance on that task will deteriorate. A language-disordered individual, who needs more effort on baseline conditions for language processing than a normal individual, will reach the limit of their capacity sooner and hence perform less well on a taxing task than a normal individual (see Butler, 1983 for discussion). The divided condition can provide these taxing conditions. Secondly, the right ear advantage for language processing during dichotic listening tasks might not exist in language-disordered individuals, due to breakdown in certain areas of the brain. Bamford & Saunders (1985) suggest this is the rationale behind the use of dichotic tests in assessment of central auditory dysfunction. For these reasons a dichotic listening test was incorporated into the stage II test battery.

3.2.3 Performance Measures

(a) PFFIN Test

In stage I OADs were found to perform less well than controls on a test of speech-in-noise. This test was run using a fixed-difficulty procedure. That is, performance was measured in terms of the percentage of sentences correctly reported at a fixed level of difficulty. However, this type of procedure does not permit interpretation of contrast between different pairs of scores, because the percent scale is not necessarily an interval scale. For example, it is not possible to be sure whether the difference between 70% and 80% is approximately equivalent to that between 30% and 40%. Second, a fixed-difficulty measure is complicated by

floor and ceiling effects, and hence different test materials or different test conditions are required when investigating individuals of widely differing abilities. Adaptive testing procedures overcome these problems by fixing the percent-correct that is scored and altering some universal metric, such as S/N ratio; hence the level of difficulty of the test can be altered on an almost unlimited scale. For these reasons the PFFIN test was modified for stage II to enable the use of an adaptive procedure.

Despite the well-known advantages described above, only in recent years have adaptive procedures become popular in audiological speech tests (e.g Plomp & Mimpen, 1979; Laurence et al, 1983; Bronkhorst & Plomp, 1988; McLeod, 1988). One probable reason is the difficulty involved in constructing sentence material for the test. An adaptive procedure requires that items within the test are of equivalent difficulty, because the presentation level of each item is determined by performance on, and therefore the difficulty of, the preceding item. If this does not hold, the threshold estimate will be unstable and inaccurate. Correction factors can be applied to each sentence after the test to correct for deviations in difficulty (Laurence et al, 1983). However, this method is inconvenient and it does not account for the bias that arises through the relationship of one sentence to another during testing. Plomp & Mimpen (1979) developed a set of Dutch sentence lists in which individual sentences were shown to be of equal difficulty. McLeod (1988) developed English sentence lists in the same way for her test of lipreading ability. Modified BKB sentence lists were used as stimuli for this version of the PFFIN test.

Self-Assessed versus Measured Speech Discrimination Ability

In stage I OAD patients were found to have a genuine performance deficit for speech comprehension in noise. However, this deficit was too small to explain their reported disability/handicap. This might arise because patients genuinely believe their hearing ability to be worse than it really is. As mentioned in chapter 2.2.1(a) self-assessed auditory disability is conventionally measured in the form of responses to a questionnaire, while actual disability is measured with some type of performance test. Individual differences in the relationship between the two measures could be difficult to interpret, since the units and methods of measurement are radically different. The discrepancy might reflect genuine misperception on the part of the listener about his/her own hearing ability. On the other hand it might reflect general inappropriateness of the performance test or misinterpretation of the questions. A well-controlled way to investigate the former possibility, without the confounding effects of the latter two, would be to measure self-assessed disability and actual disability using the same test materials that provide results in the same units of measurement. The PFFIN test was modified to run under a self-assessment condition, as well as the performance measurement condition.

**(b) Four Alternative Auditory Feature Test (FAAF) of
Speech in Quiet**

Speech audiometry in quiet is routinely carried out in many audiology clinics. Many of the OAD patients referred to IHR were described as having normal scores on a clinical test of speech-in-quiet by their referring consultant. It was felt nothing would be gained by replicating these findings using a conventional test of speech-in-quiet, but that it would be of interest to learn whether, *in comparison to controls*, OADs did show a deficit for discrimination of speech-in-quiet on a sensitive test, as well as showing a deficit for discrimination of speech-in-noise. Most tests of speech-in-quiet strongly reflect pure tone sensitivity (see Noble, 1978 for review). The Four Alternative Auditory Feature (FAAF) test, however, developed by Foster & Haggard (1979), has been shown to be sensitive to other types of minor psychoacoustic disability. It was, therefore, incorporated into the test battery as a sensitive measure of speech discrimination in the absence of noise.

3.2.4 Tests Carried Over from Stage I

In addition to these tests, results of stage I showed the OAD interview, the IHR hearing questionnaire and the Crown-Crisp Questionnaire to be valuable in characterising OAD. Hence these were re-used in stage II.

3.3 METHODS

3.3.1 Setting up of the OAD Clinic

In order to gain access to large numbers of patients a 'Special Investigative Clinic' was set up at the Institute of Hearing Research in Nottingham to serve ENT departments in the Trent Health Region. Each ENT consultant in the region (n = 33) was sent an introductory letter defining OAD, explaining the aims of the study and informing them about the clinic. They were given details of the type of patients that should be referred and informed that patients should have undergone, and proved normal upon, basic audiological/otological investigation in the ENT department. The letter and enclosures are in appendix 3.1.

The experimenter then contacted all referred patients by letter. The letter made clear the dual purpose of the clinic (i.e an audiological service in conjunction with a research element). After investigation patients were given an explanation of the findings, basic counselling/reassurance and advice about the problem. The referring consultant was sent a detailed report of the findings, and, when appropriate, given advice about patient follow-up. Appendix 3.2 contains an example of a patient report.

The running of a clinic in this way had three advantages over a more informal arrangement:

- (1) Adequate numbers of patients became accessible over a short period of time, relative to the fairly low

prevalence and incidence of the condition.

(2) Patients attending the clinic were of varied age and socio-economic group, probably because the patients themselves expected to benefit from the clinic. Possibly any bias towards a highly educated and mobile group would have been greater had the project been run only on a purely research basis in a university.

(3) It enabled an assessment of patients' and consultants' satisfaction with the testing and counselling procedures. This information was valuable when deciding elements of the test package to recommend for clinical use.

3.3.2 Subjects

OAD patients were referred to the Special Investigative Clinic by consultants in the Trent Health region. It was required that they all fit the criteria set out in a circular sent to each consultant. Any patients later found not to fit these criteria were omitted from analyses. They were, however, given appropriate clinical investigation at the Institute, and were followed-up. Appendix 3.3 contains an example of a case report of a patient visiting the clinic who was excluded from the analyses. Of 79 patients referred, 18 did not wish to attend or did not reply to our letter, 11 did not fit our criteria and so were excluded from the analyses, leaving 50 patients in the final sample. For each patient one control volunteer, matched for age, sex, educational level and noise exposure was tested. This group consisted of recontacted controls from stage 1, personal friends of

the controls and respondents to adverts placed in various locations around the city of Nottingham. Both patients and controls received travel expenses, in addition controls received payment for taking part. It is realised that these controls might not be wholly representative of the general population in all personality-related factors; (Rosnow & Rosenthal (1970) review the characteristics of volunteers). However, their willingness to volunteer can justifiably be seen to parallel the willingness of OAD patients to attend the clinic, and would therefore reduce the differences.

3.3.3 General Procedure

As in stage 1, subjects were given standard verbal instructions by the investigator before each test and there was a written summary of each test available to them in the test room. (Test instructions may be found in appendix 3.4.) Testing was carried out in a single session for the vast majority of individuals. In the case of a few controls, testing took place over two sessions. The whole procedure lasted 4 hours, this included a tea/lunch break of approximately 20 minutes. To minimise the influence of fatigue effects, the order of tests was kept the same for all subjects. Tests of similar nature were interspersed with tests of a different nature so that a subject did not remain in one testing room for longer than 30 minutes at a time. The tests are listed in table 3.1 in their order of administration.

Table 3.1 Summary of the Stage II Test Battery

OAD Interview	As for stage I, with addition of: somatic anxiety and self-confidence ratings
Pure Tone Audiogram	Pure tone threshold determination
Notch-Noise Filter Shape	Frequency resolution ability
Otoacoustic Emissions	Minor peripheral dysfunction
Self-assessed PFFIN	Measure of SELF-RATED hearing ability
Performance PFFIN	Measure of ACTUAL hearing ability, also for comparison with above
Sentence Monitoring Test	Use of context in linguistic processing
Noise Immission Rating	Quantification of noise exposure
IHR Hearing Questionnaire	Self-rated auditory disability and handicap
Crown-Crisp Q.naire	Personality inventory
BMLD	Central binaural integration
FAAF Test	Measure of speech in quiet
Lipreading Test	Measure of lipreading ability
Dichotic Listening	Central processing ability
Gap Detection Task	Temporal resolution

3.3.4 Test Battery

3.3.4.1 General Tests

(a) + (b) The OAD Interview and the Hearing questionnaire

These were administered as in stage 1 (section 2.3.3.1(a) & (b)).

(c) Adaptive PFFIN Test - Self-Assessed and Performance Conditions

Speech discrimination in noise involves, among other factors, frequency and temporal resolution and the use of binaural cues in order to locate the speech source. To date, the test that best reconciles listening in a real environment with experimental control is the Pseudo-Free-Field Speech-in-Noise test, described in section 2.3.3.1(c) and in Gatehouse (1988). The PFFIN test used in stage I was modified in stage II in order to test the following three hypotheses about OAD:

- (1) Patients have a performance deficit for speech comprehension in presence of any type of background noise.
- (2) Patients have a performance deficit for speech comprehension only in the presence of other speech.
- (3) Patients mis-judge their hearing ability, perceiving it to be worse than it really is, regardless of their actual performance ability.

The PFFIN test from stage 1 was altered in the following four ways:

(a) The test was run adaptively, rather than at a fixed S/N ratio. An explanation and the benefits of adaptive testing is given in section 3.2.3(a). Adaptive testing required the preparation of four new lists of the BKB sentences, so that sentences within, as well as between, lists were of comparable difficulty. The new lists were compiled from the original BKB lists that were used in stage 1 (Appendix 3.5 gives details of the preparation of these new lists).

(b) The test was re-recorded replacing the speech-shaped noise masker in stage I by two maskers - a white noise masker and a backwards speech babble masker. This enabled a test of hypotheses (1) and (2).

(c) The test was re-recorded under different spatial conditions from those in stage I. The speech and noise signals were symmetrical, rather than asymmetrical, around the head (figure 3.2). This simplification was felt to be suitable, because the results of stage 1 gave no indications of ear asymmetries in OAD, neither in the sense of there being consistent subjective reports of one ear being worse than the other, nor in the sense of a measurable asymmetry on any of the psychoacoustic tests.

(d) The test was run in two conditions - a 'self-assessed' condition, in which a self-assessed speech-reception threshold (SSRT) was obtained, and a 'performance' condition, in which a performance speech reception threshold (PSRT) was obtained. The SSRT is a measure of the listener's perceived hearing ability for speech-in-noise. The PSRT is a measure of the listener's

actual hearing ability for speech-in-noise. Comparison of the PSRT with the SSRT enabled hypothesis 3 to be tested.

Stimuli and Test Preparation

(i) SSRT Condition

8 original BKB sentence lists (3,7,10,11,13,14,15,16) were recorded for the SSRT condition from a sub-master copy of the BKB sentence lists. Four blocks, of two lists each, were copied onto tape. The silent interval after each sentence, present in the original recording, was removed, so that sentences followed one after the other, as in real-speech. The resulting tape consisted of four blocks of continuous speech, each 32 sentences long.

(ii) PSRT Condition

The four new BKB sentence lists were recorded as above onto the same tape. Three seconds of silence were inserted after each sentence.

(iii) Maskers

White noise was generated from an IHR noise generator. Speech babble was generated from the recording of continuous speech (used for the SSRT). It was recorded onto six tracks of an 8-channel tape recorder, the speech on each track was temporally offset so that silences in the speech did not overlap. The six tracks were then played simultaneously and recorded onto a single track of a 4-channel Revox recorder. This resulted in speech babble in which no words were individually discernible. This tape was then played backwards, creating a modulated masker of speech-like quality, that would not act as an

attentional distraction to the listener.

Recording of the Modified PFFIN Test

Recording was carried out in a sound-attenuating room through Zwislocki Couplers in the ears of a KEMAR manikin. One speaker was placed 1.5m directly in front of the KEMAR head, two other speakers were placed at 45 degrees behind KEMAR at a distance of 1.5m (speaker to KEMAR ear). The centre of the speaker was placed at a height level with KEMAR's ears (1.32m from floor). The speech and two maskers were recorded in three separate passes onto 4-channel tape. SSRT and PSRT conditions were recorded onto the same tape. The sentence lists were played through the speaker in front of KEMAR, while the two maskers were played through the two speakers to the left and right. The recording arrangements are summarised in figure 3.2. Both speech and maskers were recorded at 80dB SPL. The final recorded tape consisted of:

60 seconds of silence on all channels, followed by 60 seconds of a 1kHz calibration tone on each channel, then a further 20 seconds of silence.

Channel 1 consisted of four blocks of continuous BKB sentences (for the SSRT), followed by the four new BKB sentence lists (for the PSRT).

Channel 2 consisted of continuous speech babble, channel 3 of continuous white noise.

Figure 3.2 Recording Conditions for the Modified Pseudo-Free-Field Speech-in-Noise Test

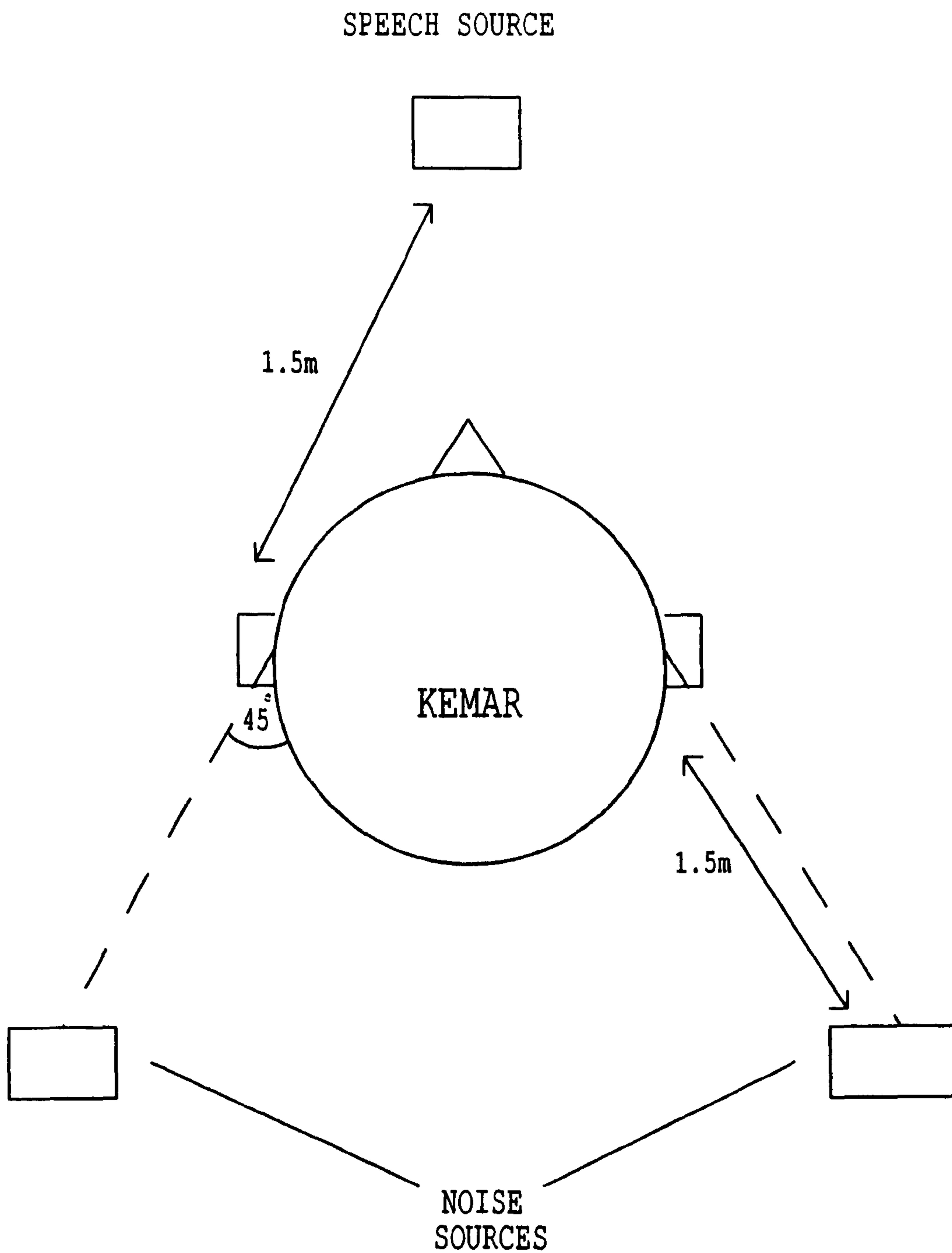

Testing Procedure

Four types of SRTs were obtained: SSRT with white noise masker (SSRTN), SSRT with speech babble masker (SSRTB), PSRT with white noise masker (PSRTN) and PSRT with babble masker (PSRTB).

SSRTs were always obtained before PSRTs. Two replicate SRTs for each masker were obtained in both conditions, resulting in four SSRTs and four PSRTs. Sentence lists were always played in the same order. To prevent effects of interactions between list and masker type, the order of masker type was used in ABBA fashion; ABBA and BAAB conditions were alternated between patients. A patient and his/her matched control always underwent testing with the same order of maskers.

For both conditions subjects listened to the sentences through TDH-49 headphones while seated in a sound-attenuating room.

(i) SSRT Condition

The SSRTN/B was obtained to determine the S/N ratio at which the listener felt just able to understand the speech signal in the presence of the masker. Masker was played at a fixed level of 65dB SPL, the speech level was altered manually in 2dB steps by the experimenter on instruction from the subject. The subject's task was to instruct the experimenter to make the speech signal 'louder' or 'quieter' until it reached a level at which he/she could "just understand everything that was being said". The term "understand" rather than "hear" was used in order that there be no ambiguity between audibility and comprehensibility. Subjects were asked to give

feedback every three or four sentences and were prompted to do so if not giving it spontaneously. The test was always started at a very favourable S/N ratio.

Attenuator levels during the first 16 sentences in each block of sentences were not noted; the attenuator level during the final 10 sentences was averaged to obtain the SSRTs.

(ii) Objective Condition

The PSRTN/B was obtained to measure the listener's actual speech discrimination ability in the presence of noise. The adaptive procedure recommended by Plomp & Mimpen (1979) was used to determine the 50% SRT. The noise level was kept constant at a level of 65dB SPL, the speech level was altered in 2dB steps manually by the experimenter. Plomp & Mimpen's paradigm is as follows:

1. The first sentence in each list is presented repeatedly, starting with an adverse S/N ratio (S/N ratio of -20dB in the presence of the noise masker, and -10dB in the presence of the babble masker). The S/N ratio is then made less adverse in 2dB steps until all three key-words in the sentence are correctly reported.
2. The S/N ratio is then made more adverse by 2dB, and sentence 2 is presented.
3. On the following trials the S/N ratio is made more adverse by 2dB if the subject reports the key-words in the sentence correctly, and is improved by 2dB if the subject reports the key-words incorrectly.

The SRT is calculated by averaging presentation levels over sentences 6-16. Sentence 16 is not actually presented, but its level is known from the subject's response to sentence 15.

The key-word 'loose' method of scoring was used.

The following variables were obtained from this test:

- (1) SSRTN (Self-assessed speech reception threshold in noise) Mean of the two SRTNs for noise masker in SSRT condition
- (2) SSRTB (Self-assessed speech-reception threshold in babble) = Mean of the two SRTs for babble masker in the SSRT condition
- (3) PSRTN (performance SRTN) = Mean of the two SRTs for the noise masker in the PSRT condition
- (4) PSRTB (performance SRTB) = Mean of the two SRTs for the babble masker in the PSRT condition
- (5) PS-DISN (Performance - self-assessed discrepancy with the noise masker) = PSRTN minus SSRTN
- (6) PS-DISB (performance - self-assessed discrepancy with the babble masker) = PSRTB minus SSRTB

**(d) The Four Alternative Auditory Feature Test
the Band-Filter Version**

The Four Alternative Auditory Feature (FAAF) test was specially designed for diagnostic purposes. It is a four-alternative forced-choice test consisting of sets of minimally-paired words, in which confusions made in place, manner and voicing can be analysed. The test can be presented under a variety of conditions (Foster & Haggard, 1979 and 1984 give further details). Here, the band-filtered version presented in quiet is used as measure of speech processing in quiet. The band-pass filtering leaves signal present between 0.1-0.6kHz and 4.8-6.0kHz. This enables a test of two hypothesis, although they cannot be dissociated from one another: (i) that OADs are unable to use extremely high- and/or low-frequency energy for speech processing, but rely on high to mid-frequency energy, which is often of low intensity, and masked in noisy situations; and (ii) that OADs are less good at extrapolating information from partially missing auditory signals.

Stimuli

The stimuli consist of 20 sets of four minimally-paired words, in the carrier sentence "Can you hear x clearly?", giving a total of 80 stimuli (see Foster & Haggard, 1979). The stimuli were band filtered. The remaining signal contains energy between 0.1-0.6kHz and 4.8-6.0kHz. Sentences were digitised as described in Foster & Haggard (1984) into a Z-2 computer. They were played from the computer, via IHR Universal filters to Sennheiser HB414 headphones.

Procedure

The subject was seated in a sound-attenuating room, in front of a VDU. The sentences were played diotically through the headphones at a level of 70dB SPL. 3 seconds before each, the test word and three other words appeared on the screen. Subjects had to decide which of these words they had heard, and respond by pressing the appropriate button on a response-box. The subsequent stimulus did not begin until a response to the prior one had been made.

The FAAF scoring programme analyses the results by error-type, as well as by overall performance. For the purposes of this investigation only overall score was used in the statistical analyses.

3.3.4.3 Psychoacoustic Tests

(a) Pure Tone Audiogram

This was carried out as in stage I; additionally thresholds at frequencies of 125Hz, 750Hz and 1500Hz were obtained.

(b, c, d) Frequency Resolution, Temporal Resolution and Binaural Masking Level Difference (BMLD)

(b) Frequency resolution was measured using a two-data-point estimation of filter width by the notched-noise technique (Patterson et al, 1982). Masked thresholds are determined for a pure tone (probe tone) in the presence

of a low-pass masker, and a low-pass masker with a wide notch centered on the probe tone frequency. In normally-hearing listeners the masked threshold for the notch condition is lower than for the no-notch condition. In listeners with widened auditory filters, however, the difference between masked thresholds for the two conditions is less.

(c) **Temporal Resolution** was measured using a gap detection test. The subject is presented with three long duration signals of narrow-band noise, one of which contains short temporal gap. The shortest duration of gap that the subject can reliably detect is determined, this is the gap detection threshold. Poor temporal resolution is shown by longer gap detection thresholds.

(d) **The Binaural Masking Level Difference (BMLD)** was measured for a tone in narrow-band noise, for N_0S_0 and N_0S_{Pi} conditions. Release from masking (a BMLD) occurs for binaural presentation when the tones to the two ears are out of phase. Reduced BMLDs are found in individuals with impaired binaural integration, fusion and separation ability.

Equipment

Figure 3.3(a) shows the experimental setup for measurement of frequency and temporal resolution, figure 3.3(b) shows that for BMLD determination. Calibration of the equipment was carried out before each test session, using a voltmeter. Filter shapes were checked on an oscilloscope. Stimulus presentation was controlled via a Z-2 micro-computer. Output was through TDH-49 headphones.

Figure 3.3(a) Experimental Setup for Measurement of Frequency and Temporal Resolution

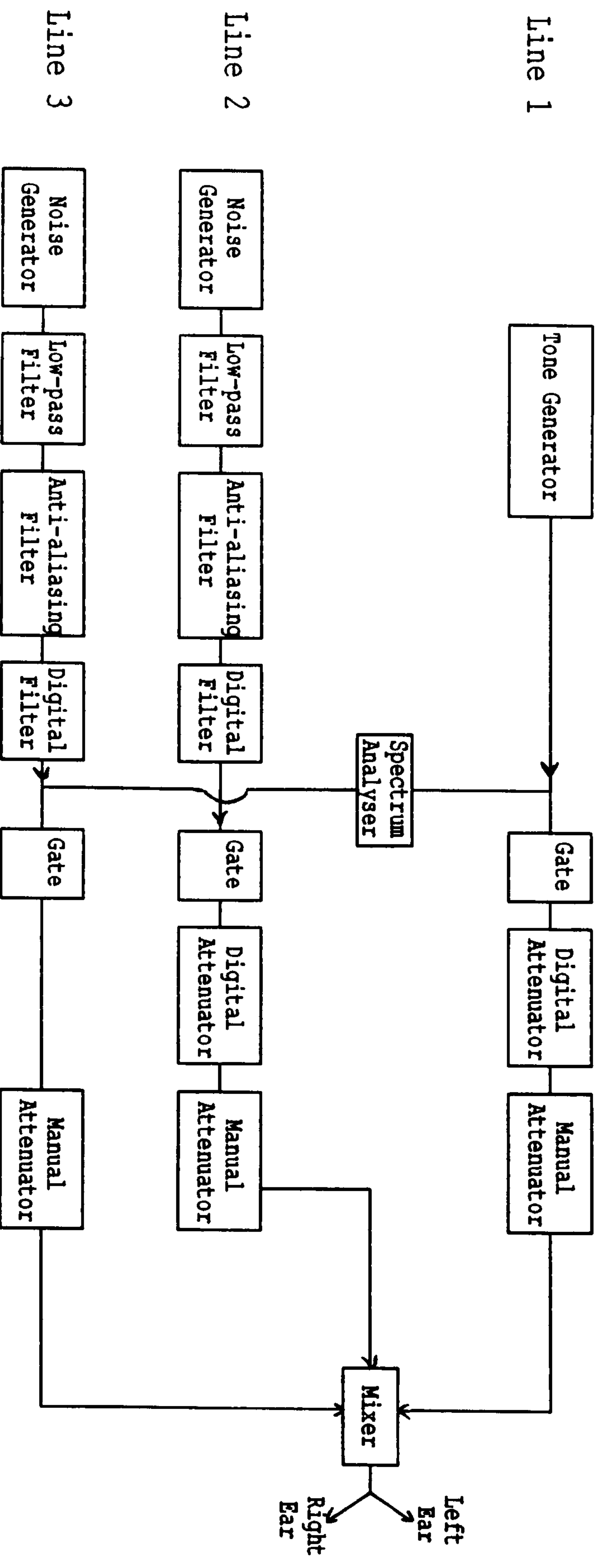

Frequency Resolution: Lines 1, 2, and 3

Temporal Resolution: Lines 2 and 3

Figure 3.3(b) Experimental Setup for Measurement of Binaural Masking Level Difference (BMLD)

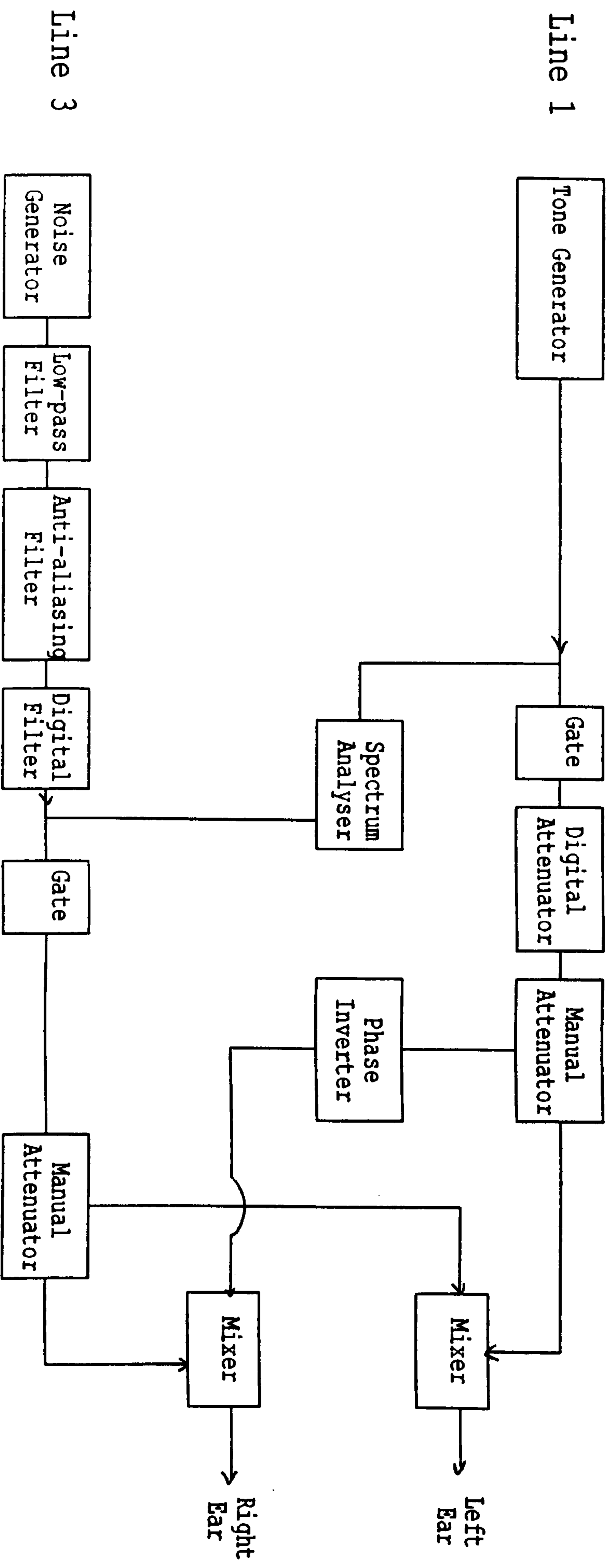

Stimuli

Levels of all stimuli were calibrated using manual attenuators, but controlled during the experimental procedure by a digital attenuator. Stimuli for frequency resolution and BMLD measurement were presented at spectrum levels of 58.8dB SPL. Spectrum levels were raised slightly in the temporal resolution experiment so that the signals were clearly audible. Figure 3.4a gives a schematic representation of spectra of the stimuli in each experiment, and figure 3.4b gives a schematic representation of the temporal structure of each experiment.

(b) Frequency Resolution

A probe tone of 2kHz tone was generated from a Hewlett-Packard 3325A tone generator. Its level was varied adaptively throughout the experiment. The tone burst was 200ms, occurring 400ms into the 1000ms masker burst. Tone and masker(s) had a rise-fall time of 20ms. The no-notch masker was a low-pass 8kHz filter. The notch-masker was a band-pass filter to 8kHz, containing a 1000Hz-wide notch centered at 2kHz. Spectrum levels of the maskers were uniform at 35dB/Hz. The low-pass masker for the no-notch condition was presented at 74.0dB SPL, the notch condition masker was presented at 73.3dB SPL.

(c) Gap Detection

The signal was a band-limited noise of 250Hz wide, centered on 500Hz. It was gated on and off with a rise-fall time of 5ms. The gap began 480ms into a 1000ms tone

Figure 3.4(a) Spectral Representation of the Stimuli used for measurement of Frequency Resolution, Temporal Resolution and Binaural Masking Level Difference (BMLD)

(i) Frequency Resolution

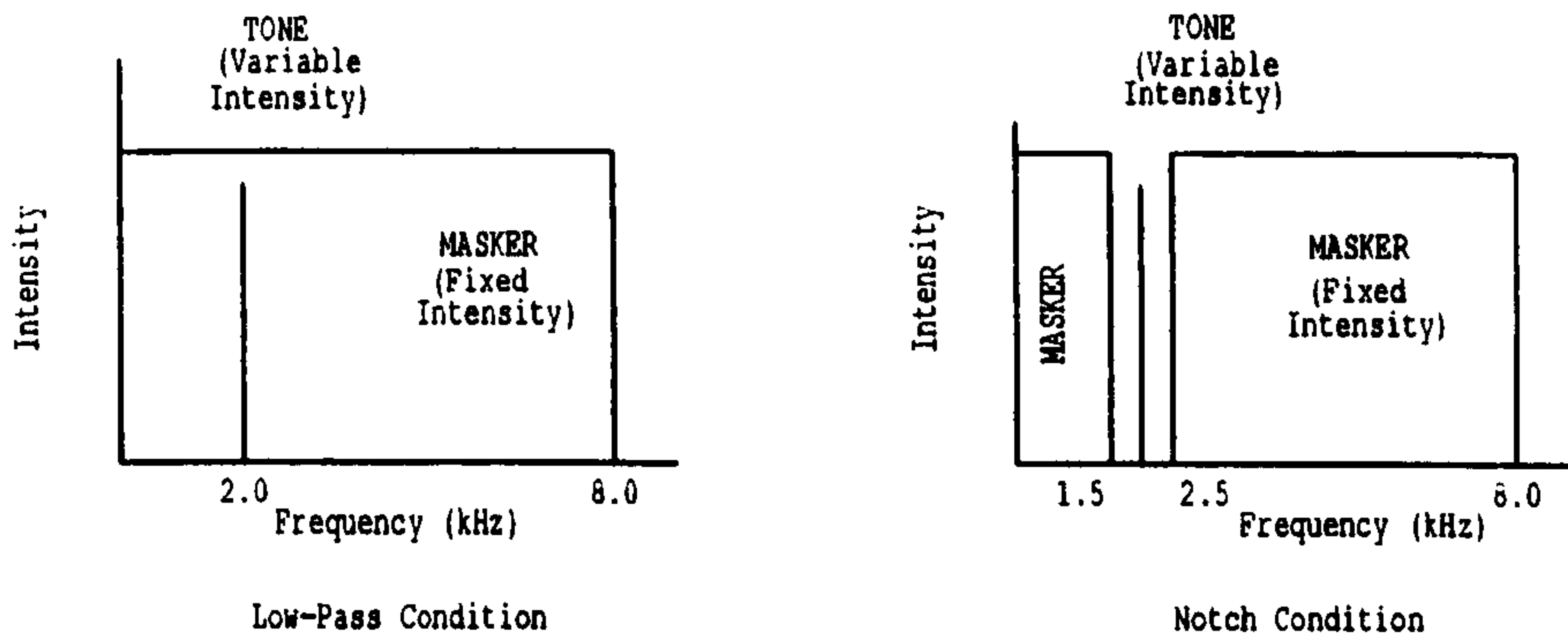

(ii) Temporal Resolution

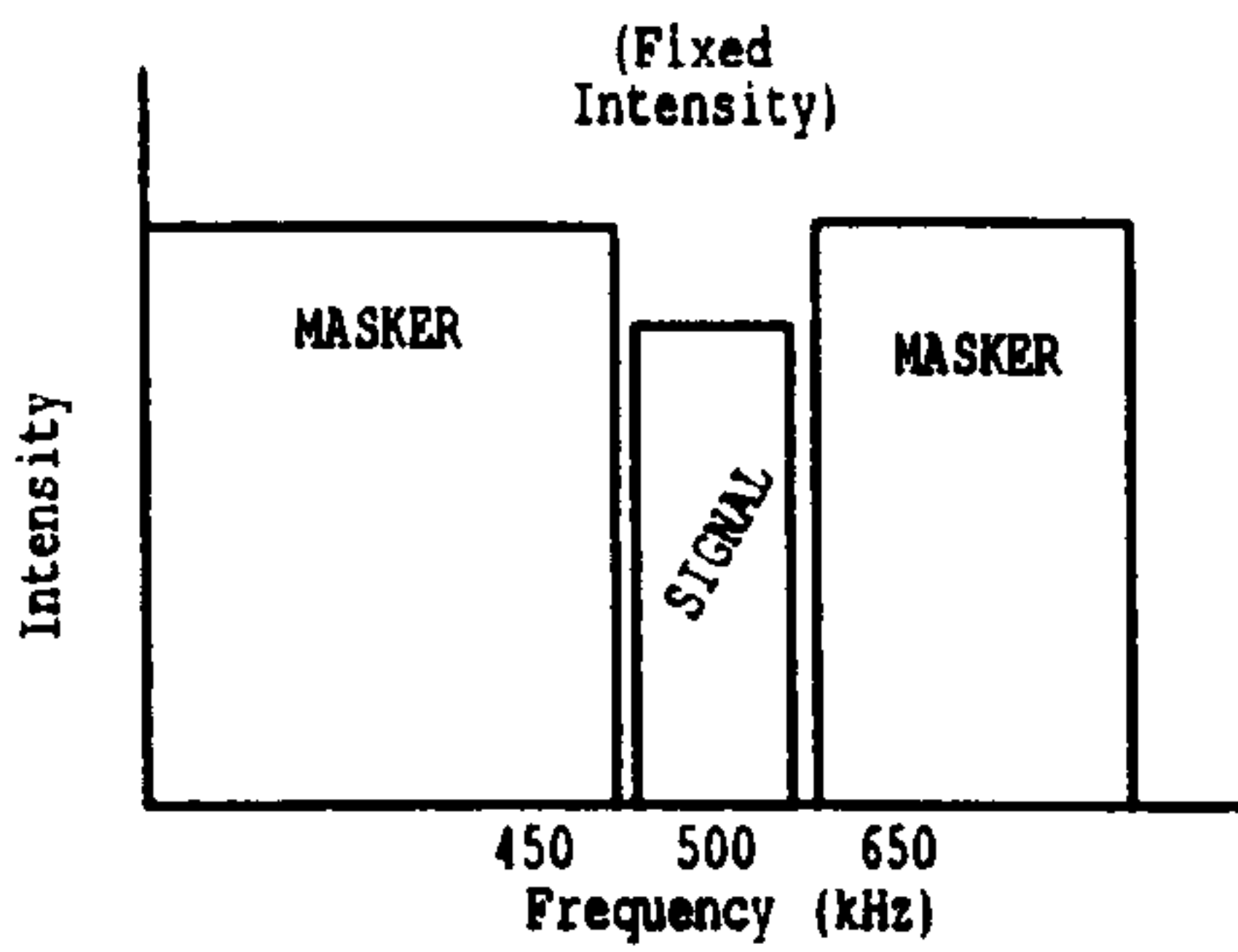

(iii) BMLD

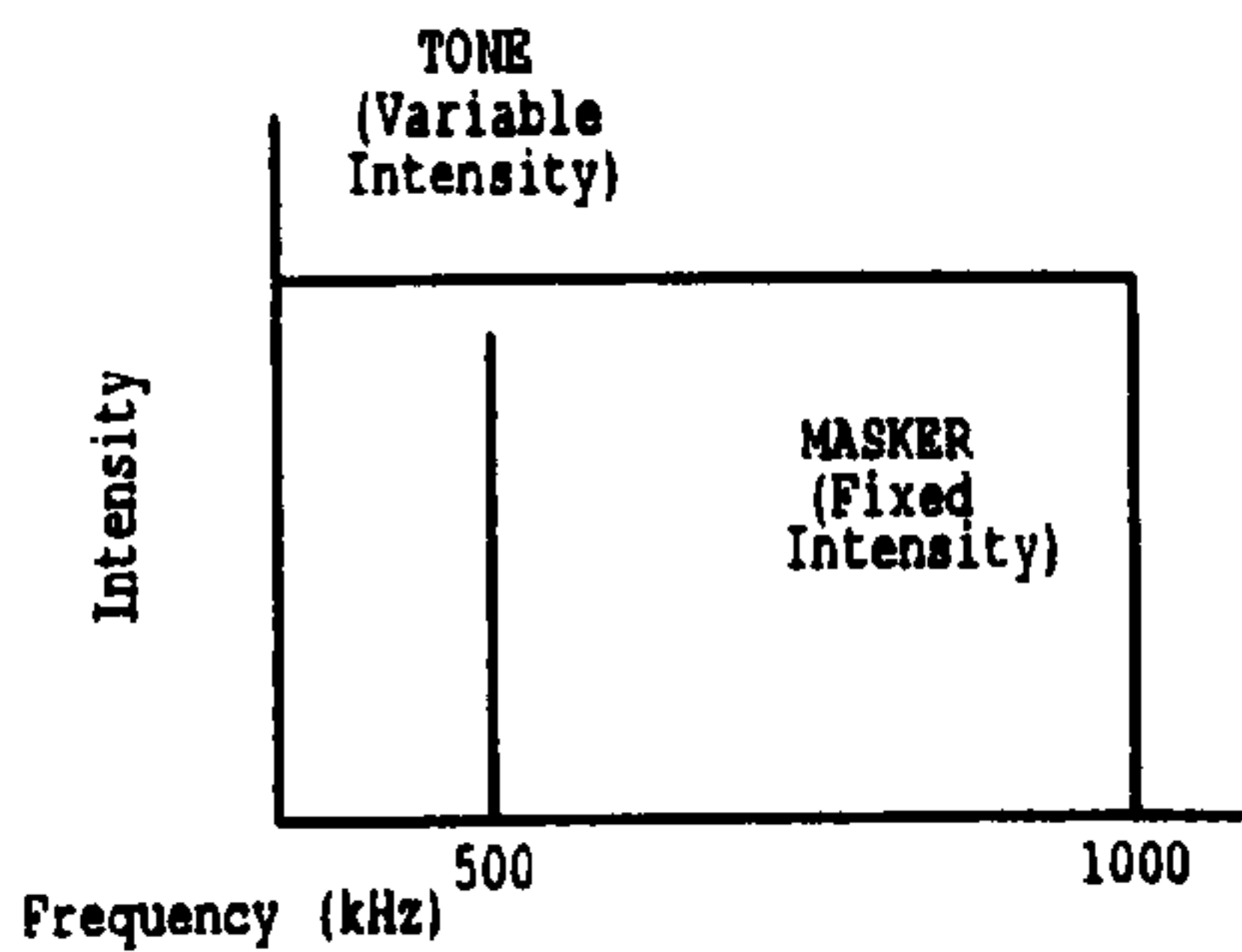
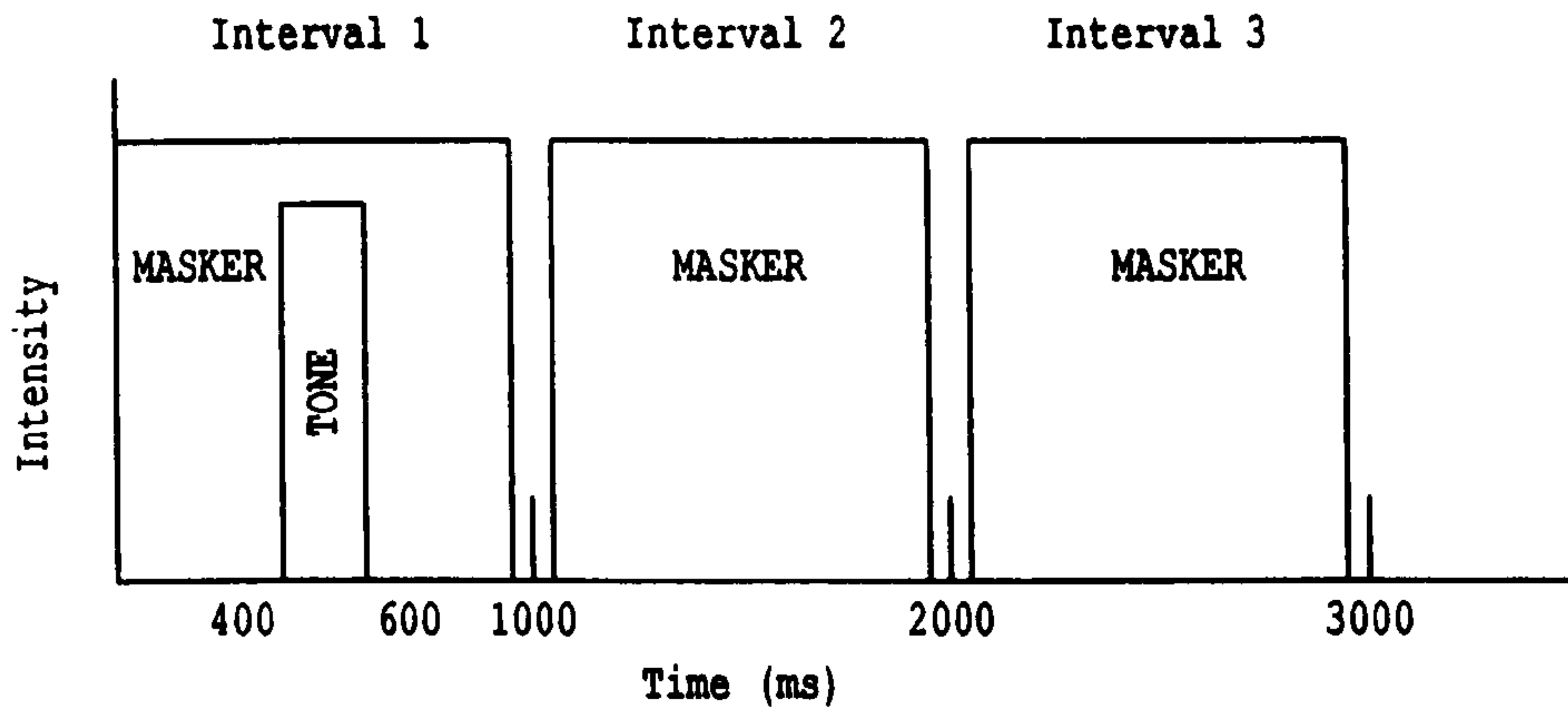
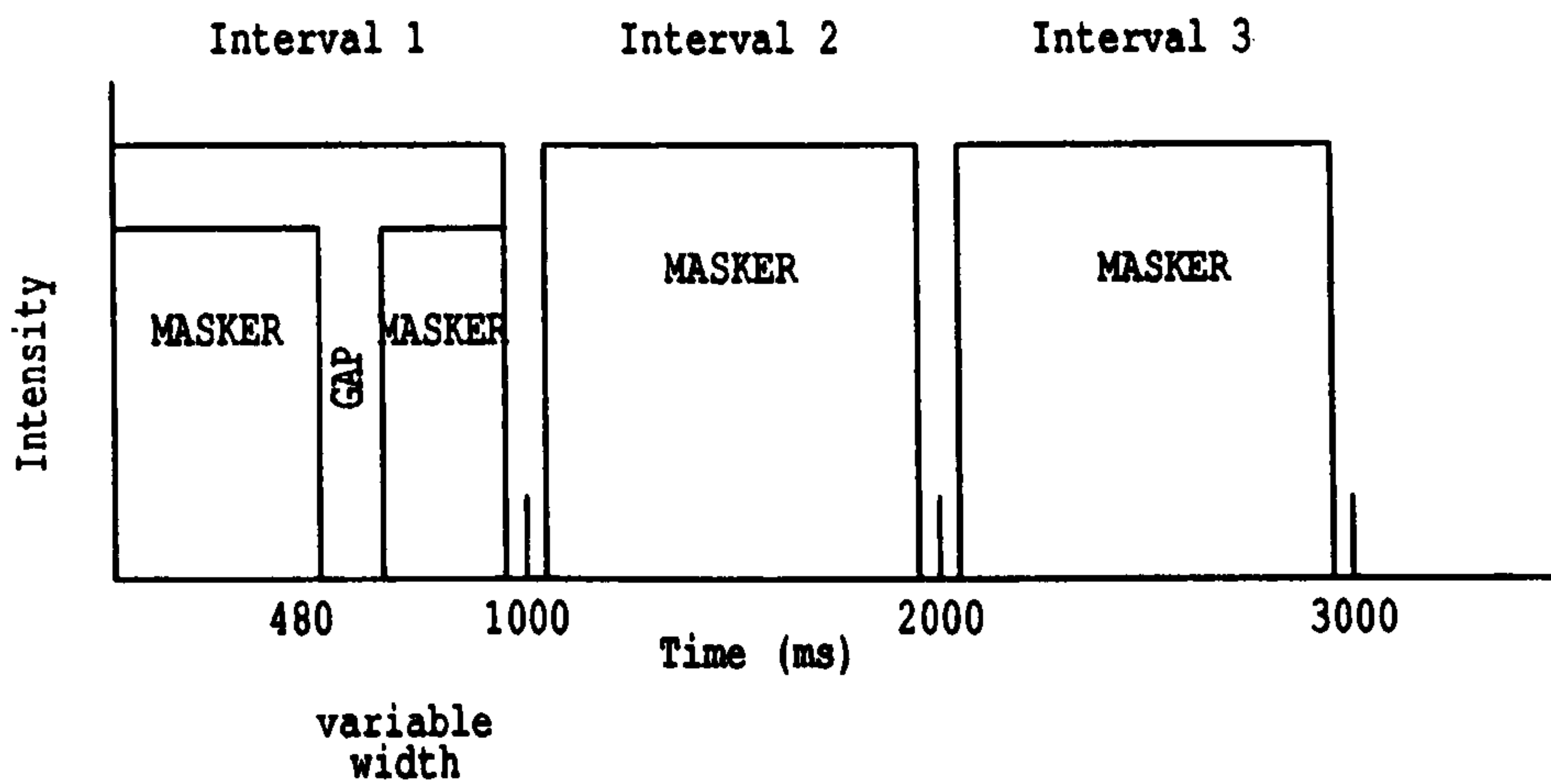

Figure 3.4(b) Temporal Representation of Stimuli used for Measurement of Frequency Resolution, Temporal Resolution and Binaural Masking Level Difference

(i) Frequency Resolution



(ii) Temporal Resolution



(iii) BMLD

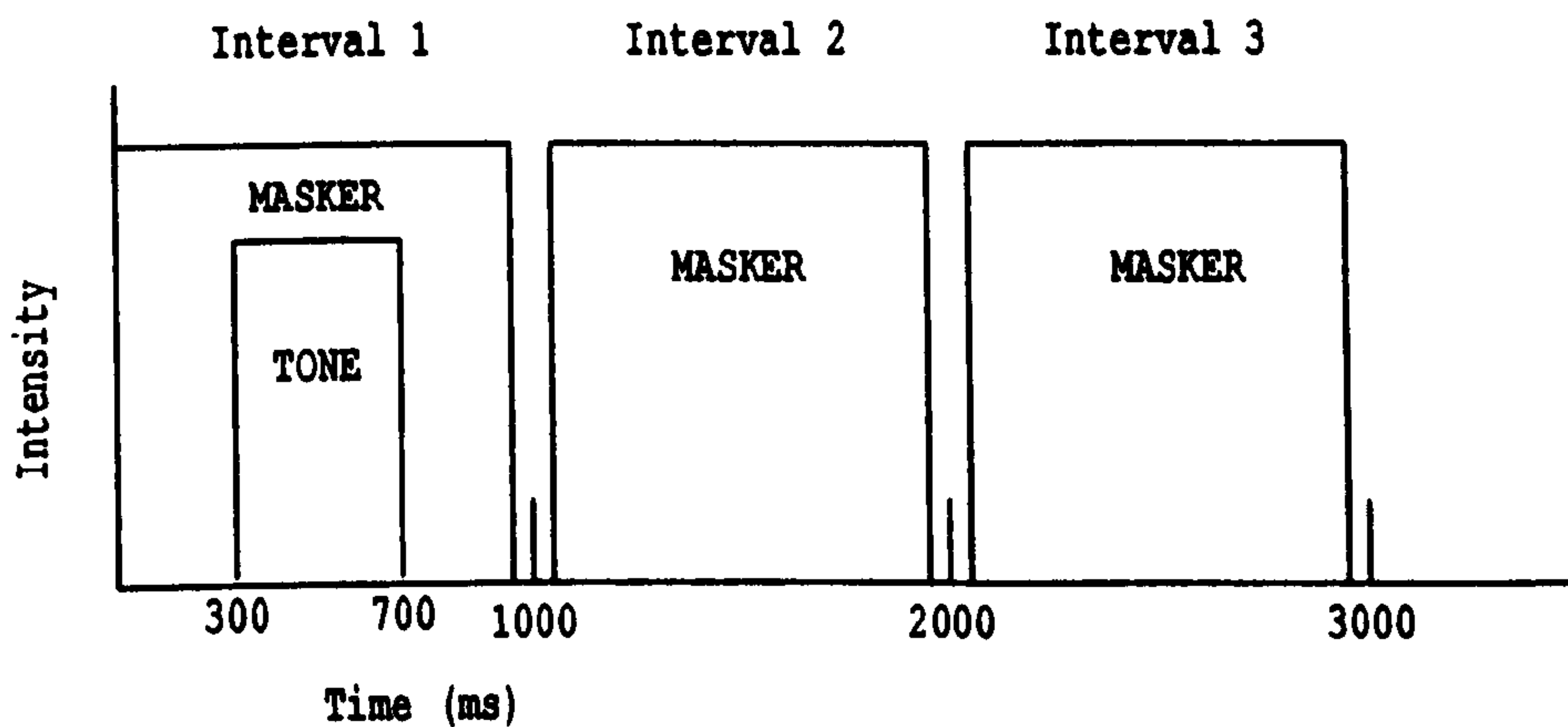

burst. Its duration was varied adaptively through the experiment. A low-pass filter 0-900Hz, with a 300Hz notch centred on 500Hz was used to prevent off-frequency listening. Spectrum levels were uniform for signal and masker at 40dB/Hz. The signal was presented at a level of 69.0dB SPL, the masker at a level of 72.dB SPL.

(d) BMLD

The signal was a 500Hz pure tone, presented in either N_0S_0 or N_0S_{Pi} conditions. The level of the tone was varied adaptively during the experiment. It was gated on for 400ms with a rise-fall time of 20ms. A 1kHz low-pass filter with a uniform spectrum level of 35dB/Hz was used a the masker. It remained on continuously throughout each run at a level of 70dB SPL.

General Procedure

Subjects were tested in a sound attenuated booth. Stimuli were presented monaurally in the frequency resolution and gap detection experiments, and binaurally in the BMLD determination. A 3IFC paradigm (described in chapter 2) was used to determine the 79.4% threshold; it varied slightly for each experiment:

(b) Frequency Resolution

Masker levels were kept constant. The level of the probe tone was decreased after three correct responses, and increased after one incorrect response. Initial step-size was 8dB for the first 3 reversals and 2dB for the

remaining 4 reversals. Threshold was calculated by averaging the tone level at the final four reversals.

(c) Gap Detection

All levels were kept constant throughout the experiment. Gap duration in the signal was decreased after 3 correct responses and increased after 1 incorrect response. The step-size for the first 3 reversals was 6ms, and 1ms for the following 4 reversals. Gap threshold was calculated by averaging the gap duration at the final 4 reversals.

(d) BMLD

Masker level was kept constant throughout the experiment. The level of the probe tone was decreased after 3 correct responses and increased after one incorrect response. Initial step-size was 8 dB for 3 reversals, and 3dB for the remaining 4 reversals. Masked threshold was calculated by averaging the tone level at the final 4 reversals.

Sequencing and Counterbalancing within Experimental Tasks

(b) Frequency Resolution

Masked thresholds were determined in the order:

1. Notch masker left ear
2. Low-pass masker right ear
3. Low-pass masker right ear
4. Notch masker left ear.

This achieves order counterbalancing of ear and condition at the expense of the interaction of ear x condition.

(c) Temporal Resolution

Gap detection thresholds were determined in the order:

1. Left ear
2. Right ear
3. Right ear
4. Left ear.

(d) BMLD

Masked thresholds for BMLDs were determined in the order:

1. N_0S_0
2. N_0S_{Pi}
3. N_0S_{Pi}
4. N_0S_0

The following variables were obtained from these tests:

(b) Frequency Resolution

- (1) Mean of notch left and notch right thresholds
(Mid-frequency notch condition masked threshold)
- (2) Mean of no-notch left and no-notch right thresholds
(Mid-frequency low-pass condition masked threshold)
- (3) Mid-frequency notch minus mid-frequency low-pass
masked threshold (Frequency resolution)

(c) Temporal resolution

- (1) Mean of left and right gap thresholds (gap detection
threshold)

(d) BMLD

- (1) Mean of $N_0 S_0$ thresholds (Low-frequency 1
masked threshold)
- (2) Mean of $N_0 S_{Pi}$ thresholds (Low-frequency 2
masked threshold)
- (3) Low-frequency 2 minus low-frequency 1 masked
threshold (BMLD)

(e) Measurement of Evoked Otoacoustic Emissions (EOEs)

This is a physiological, rather than a psychoacoustic test to measure evoked otoacoustic emissions from the ear. The mechanism generating the echos is not yet understood, but appears to be susceptible to the same treatments as those known to affect function of the cochlear (Anderson & Kemp, 1979). Rutten (1980) found that in some individuals EOEs were absent at frequencies where thresholds were between 15 and 20dB. EOEs were, therefore, measured to investigate the possibility that

OADs have minor cochlear pathology that manifests itself as an absence or incoherence of EOE's, in the same way as that found by Rutten.

Procedure

EOEs were measured using the IHR Programmable Otoacoustic Measurement System (POEMs) equipment and testing protocol (Cope & Lutman, 1988). A small microphone is placed in the subject's ear canal. 1024 click stimuli are played to the ear at a rate of 50 clicks per second, the response of the ear is recorded and averaged by computer. The test is carried out at stimulus intensities of 40, 50, 60 and 70dB SPL; each intensity is repeated once. The averaged emission is printed on the computer screen, as is the correlation between the replicates at each intensity. The acoustic emissions were then analysed by Lutman's acoustic emission analysis programme.

The following variables were obtained from this test:

- (1) Expert ratings of the presence of an emission in each trace
- (2) Fsp values (S/N ratio values for each trace)
- (3) Correlations between replicates
- (4) Coherence functions of replicates
- (5) Power spectra of the averaged replicates

3.3.4.3 Central/Cognitive Tests

(a) Audiovisual Test

The hypothesis that OAD patients are below average lipreaders was tested using this audiovisual test. A measure of lipreading ability is obtained that is neither confounded by the subject's psychoacoustic ability nor linguistic skill. The rationale behind the test is described in section 3.2.2(a). and in more detail in McLeod (1988). Some of the sentences developed by McLeod (1988) are played in the presence of a white noise masker of fixed level. Two binaural speech reception thresholds in noise are determined, one for audiovisual presentation (VSRTN) and the other for audio-alone presentation (ASRTN). By subtracting the ASRTN from the VSRTN a measure of lipreading benefit is gained. See McLeod (1988) for further details and for development of the test.

Stimuli

Three lists of McLeod's sentences, with 16 sentences in each, were selected on the basis of their being of equivalent difficulty. See appendix 3.6 for the sentences. They were copied from her sub-master video-tape onto another video-tape. The first list, presented always under audiovisual conditions, was used as practice, lists 2 and 3 were test lists always presented in the order auditory-alone followed by audiovisual presentation. Between each sentence there was a silent interval of 10s seconds, to allow time for responding. A white-noise masker served as background noise.

Procedure

Subjects were seated in a sound-attenuating room, approximately 1.5 metres from a 21-inch monochrome video monitor. Sentences were played through Sennheiser HB414 headphones in the presence of white noise at a fixed level of 60dB SPL. The subject's task was to repeat aloud as much of each sentence as they heard. The adaptive procedure recommended by Plomp & Mimpen (1982) was used to determine the 50% SRT (section 3.3.4.1(c) gives details).

The following variables were obtained from this test:

- (1) Auditory-alone SRTN (ASRTN)
- (2) Audio-visual SRTN (VSRTN)
- (3) Lipreading ability = VSRTN minus ASRTN

(b) Dichotic Listening Test

This test was designed to test the possibilities that OAD patients have a mild form of central auditory dysfunction or a mild linguistic deficit that will manifest itself when the auditory system is placed under difficult perceptual conditions. Subjects were presented with lists of dichotic word pairs. Their task was to monitor the input to either the left ear, or to the right ear, or to both ears simultaneously, and to report aloud words in two types of category. Category 1 was a semantic category for which food and drink words were monitored, category 2 was a phonemic category for which words beginning with a specified letter of the alphabet were monitored, this

letter changed with each list.

Stimuli

3 lists of dichotically presented pairs of words (56 pairs in each) were recorded onto tape, at a rate of 60 pairs/minute. Appendix 3.7 gives details about the preparation and the final lists of stimuli used. Each list contained 8 words in the semantic category food and drink, and 5 to 8 words in a phonetic category¹. Each test list was heard three times, once under each condition, giving a total of 9 lists. List order and condition order were balanced as follows:

LIST	CONDITION
1	Left
2	Right
3	Both
1	Right
2	Both
3	Left
1	Both
2	Left
3	Right

¹The number of phonetic targets in each list differed because the test was originally designed with just 8 semantic targets (of which there are equal numbers in each list), based upon the work of Johnston & Wilson (1980). However, piloting showed this task was too easy. In order to make the task more difficult the phonetic category was introduced, but after the test materials had been recorded. The phonetic category was chosen so that lists were as equivalent as possible in terms of the number of phonetic targets. It was not possible, however, to achieve perfect balancing between lists (Appendix 3.7 gives details).

In addition to the test lists, a practice list of 20 word pairs was prepared. The first 10 pairs were played at a rate of 20 pairs/minute, the remaining 10 pairs were played at the test rate (60 pairs/minute). During the practice list subjects monitored just the left ear for words in the semantic category 'relatives'.

Procedure

Word pairs were played from a two-channel Revox tape recorder to TDH-49 headphones. Prior to the start of each list the subject was told which ear(s) of input to monitor and which categories of word to report. Subjects were told that if they should forget which ear or category they were monitoring part way through a list, they should ask the experimenter to remind them.

The following variables were obtained from this test:

- (1) Percent correct left ear report
- (2) Percent correct right ear report
- (3) Percent correct both ears report = percent correct divided attention condition
- (4) Percent correct for focussed attention condition = average of percent correct for left and right ear report.

(c) Sentence Monitoring Test

This test was designed to test the hypothesis that OAD patients are less able than controls to use contextual information to aid linguistic processing. The subjects' task was to monitor a spoken sentence for a target word

in a pre-specified semantic category (e.g a vehicle, food etc). On hearing the target word they had to respond as quickly as possible, by pressing a button on a response box. There are four test conditions between which the 'predictability status' of the target word differs. In condition 1 the target word is syntactically and semantically predictable, in condition 2 it is syntactically predictable, but semantically unpredictable, in condition 3 the target word is neither semantically nor syntactically predictable, and in condition 4 there are no target words. This condition was included to check that subjects were not responding randomly.

Stimuli

The test consisted of 20 sentences per condition, giving a total of 80. There were 10 categories of target word, 8 noun categories, 1 verb category and one adjectival category. In each category there were 2 different target words. Every target word appeared once in each condition (excepting the "null" condition). Appendix 3.8 contains details of the construction, piloting and final sentences.

Procedure

Sentences were recorded onto a Z-2 computer. They were then played from the computer in a pseudo-randomised order, through IHR attenuators into Sennheiser HB414 headphones. The subject was seated in a sound-attenuating room, in front of a VDU and a response box. Sentences were played diotically through the headphones at 70dB SPL. 3.5 seconds prior to the playing of each sentence

the target category appeared on the screen of the VDU. On hearing the target word the subject responded as quickly as possible by pressing a button on the response-box. If no response was made within approximately 2.5 seconds of the target word, the subsequent trial began. At the onset of each sentence presentation a software timer on the computer was triggered. The timer was stopped when the response-box had been pressed. This is referred to below as 'raw reaction time'.

Scoring of the test

Positions of target words in ms from the onset of the sentence were calculated using a wave-form analyser programme on a Z-2 computer. Real reaction-time was calculated by subtracting target word position from the raw reaction time for each sentence. Real reaction times were average for each sentence within one condition.

The following variables were obtained from this test:

- (1) MEANP = mean reaction times for sentences in the 'predictable' condition.
- (2) MEANU = mean reaction times for sentences in the 'unpredictable' condition.
- (3) MEANN = mean reaction times for sentences in the 'nonsense' condition.
- (4) MEANNULL = mean reaction times for sentences in the 'null' condition.
- (5) MEANPUN = mean of MEANP, MEANU, and MEANN
- (6) PUDIFF = difference in reaction times for the 'predictable' and 'unpredictable' conditions
- (7) PNDIFF = difference in reaction times for the 'predictable' and 'nonsense' conditions

- (8) UNDIFF = difference in reaction times for the 'unpredictable' and 'nonsense' conditions

3.3.4.4. Tests of Personality-Related Factors

(a) The Crown-Crisp Questionnaire

This was used as in stage I (section 2.3.3.4a).

(b) Mis-judgement of Hearing Ability

The degree to which an individual mis-judges their hearing ability is measured as described in section 3.3.4.1(c) above, by the discrepancy between self-assessed and performance speech reception thresholds in noise.

Appendix 3.9 contains a summary of all variables obtained during stage II that are referred to below. These sheets can be removed from the plastic folder so that the reader can easily refer to the list while reading the remainder of the thesis.

3.4 RESULTS

3.4.1 Patient Profile

The following paragraphs summarise the clinical and demographic profile of the 50 OADs in stage II, and gives a breakdown of the diagnoses made about each individual, as reported to the referring ENT consultant. This information is presented before the test results and discussion of group differences to give the reader a general understanding of the type of individual involved.

The average age of the OADs in this sample was 31.2 years. Although the cut-off criterion for age was 55, the sample is still biased to younger individuals. This is probably because pure tone sensitivity deteriorates with age, hence many older individuals would have had a minor peripheral loss at the initial consultation and so would not have been referred to the clinic. It is unlikely that OAD is a syndrome specifically found in young individuals.

The ratio of women to men was 33:17, i.e women are more strongly represented in this sample than men. This is consistent with other literature showing that medical consultation rates are higher among women than among men (Bucquet & Curtis, 1986; Hunt et al, 1981, 1985)

42% of OADs had qualifications of degree/diploma level, 46% had school-level qualifications (CSE, 'O' or 'A' level), while 12% had no educational qualifications. As compared to the general population OADs are a very highly educated group. These findings are not consistent with

those of Bucquet & Curtis, (1986) or Hunt et al (1981, 1985) who report that individuals of social classes IV and V tended to report greater morbidity than those in classes I and II. Similarly the Office of Population Census and Surveys (1979) and Crombie (1984) found individuals in social classes IV and V consulted medical advice more frequently than those in social classes I and II. These conflicting group compositions are possibly understandable in terms of the nature of OAD (see below). Another factor that should be considered here, however, is the possibility that there are similar numbers of OADs in all educational groups, but that those who declined to attend the clinic were the less well-educated individuals. This could not be empirically investigated in detail because the information about non-attenders was obviously missing. However a fair proportion of those who did not reply to our invitation did not have a telephone (5/19 - suggesting they were from a lower socio-economic group) and a further 4 were known to have manual jobs. No details are known about the other 10 individuals that did not attend the clinic. Although this evidence is far from conclusive, there does seem to be an educational bias in terms of those who did not attend the clinic. This should be considered when describing the profile of a typical OAD patient, and when considering the location of future OAD clinics (section 4.2.1.4).

Comparison of the NIR ratings of OADs with those obtained by the National Study of Hearing for the general population showed OADs as a group to have significantly higher ratings (Men: $X^2=10.7$, $p<0.01$; Women: $X^2=8.0$, $p<0.02$). Pick & Evans (1983), in their study of individuals with OAD-like symptoms, found all of their subjects had a strong history of noise exposure in conjunction with poor frequency resolution. In this

population, however, frequency resolution ability and noise exposure were not as strongly linked, as shown by the nonsignificant difference in frequency resolution ability among OADs with a history of noise exposure and those without. Similar results were obtained before and after taking pure tone sensitivity into account with ANCOVA (without accounting for pure tone sensitivity: $F=0.01$, n.s; accounting for pure tone sensitivity: $F=0.00$, n.s). Results were also null for comparison of controls with and without a history of noise exposure (without accounting for pure tone sensitivity: $F=0.01$, n.s; accounting for pure tone sensitivity: $F=0.03$, n.s).

Regarding the main clinical complaints expressed, 64% of patients reported difficulties hearing speech in all types of background noise; the remaining 36% report that their problems are specific to speech-noise. Those with the former complaint mainly found party/pub-noise disturbing, but also factory machinery. Many of those with the latter complaint noticed their problem in the work environment (meetings, classrooms, lecture-halls). These are the sort of circumstances primarily faced by professional people such as teachers, and by businessmen. This possibly explains the bias to a well-educated group of individuals. Chi-square analysis, however, showed a non-significant relationship between educational level and type of complaint. Similarly, there was no relationship between type of complaint and psychoacoustic abilities (frequency and temporal resolution, masked thresholds nor SRTN score) as calculated by dividing the group into good versus poor performers at the median value, and then doing a chi-square analysis.

The majority of OADs (60%) had noticed their problem within the last three years and of these, 90% had then

consulted a doctor within 1 year. 28% of patients had noticed their problem more than 5 years ago. Chi-square analysis showed no relationship between anxiety level and the length of time since noticing the problem, nor between anxiety level and time to consultation. Similarly there was no relationship between self-rated disability/handicap (i.e. perceived 'severity' of the problem) and either of these variables.

The reasons given by patients for consulting a doctor were diverse: 30% consulted because of worries that their hearing was deteriorating, 26% reported that they had become 'fed-up' with not hearing properly and so had consulted with the aim of having the problem 'cured', a further 12% consulted because they assumed wax in the ear canal was causing their hearing problems, 12% mentioned their hearing difficulties while consulting the doctor about an unrelated problem, 18% were prompted by others to seek attention, and one individual (2%) consulted as a possible means to get compensation for noise-induced hearing loss (not, in fact present in conventional form).

28% of patients reported an asymmetry in their hearing, although only half of these mentioned the asymmetry spontaneously. The remaining 74% of patients had not noticed any asymmetries in their hearing abilities. Chi-square analysis showed no relationship between psychoacoustic abilities and reports of asymmetrical hearing, however the analysis was not done by matching ear of complaint to psychoacoustic ability in that ear.

The majority of patients (62%) reported they were not concerned about comments made by others about their hearing, 8% became upset by such comments, 10% felt

angered, and 6% were embarrassed. The remaining 14% had never received comments.

In summary, subject to the caution about a possible educational bias in attendance of the clinic, this profile shows OAD patients to be a well-educated group whose work/social activities often rely upon verbal communication. This possibly explains why they were particularly aware of minor hearing difficulties (real or perceived), and hence why they consulted a doctor almost immediately they had noticed the problem. The absence of strong reports of ear asymmetry tends to imply that a purely psychoacoustic explanation of OAD is unlikely. The fact that the majority did not seek consultation primarily because of serious worries about their hearing deteriorating suggests that these patients are not simply an over-anxious group. The finding that the majority are not bothered by others' comments suggests that they are not an exceptionally shy/sensitive group of individuals. Finally, the finding that some had not received any comments from others about their hearing possibly suggests a mis-alignment of perceived versus actual hearing ability.

A breakdown of the diagnoses for each individual, given in the report to the referring consultant can be broadly summarised in table 3.2. The test battery enabled a given diagnosis to have a psychoacoustic basis, a cognitive basis, a personality-related basis, a lipreading basis or some combination of two or more of these.

Table 3.2

Summary of diagnostic profile of patients as given in report to referring consultant

Number of domains in diagnosis	Percent of patients
1	36
2	58
3	4
unconfirmed basis	2

Specific domains in diagnosis	Percent of patients
Psychoacoustic (PA)	6*
PA + cognitive	10*
PA + personality-related (PR)	12*
PA + lipreading deficit (LR)	2
PA + cognitive + PR	2
PA + LR + PR	2
Cognitive alone	-
Cognitive + PR	2
Cognitive + LR	10
LR alone	2*
LR + PR	22*
PR alone	28*
Unidentified basis	2

*=one individual (2%) with this diagnosis was referred for neuro-otological and/or electro-physiological investigation on the basis that the findings were unable to explain all of his/her reported symptoms.

3.4.2 UNIVARIATE ANALYSES

As for stage I, univariate analyses were carried out to test for group differences between OADs and controls on the many variables measured. On the basis of stage 1 it was hypothesised that OADs as a group would have poorer performance on psychoacoustic and cognitive measures, while also having more extreme values on tests of

personality-related measures. ANOVAs, t-tests and chi-square analyses were carried out to look at raw group differences, ANCOVAs were used to investigate interrelations between certain variables. Appendix 3.10 contains a reliability correlation matrix and other within-test reliability indices. The test-retest correlations are sufficiently high as to validate the between group analyses.

3.4.2.1 OAD Status

11 patients were rejected from the sample on the basis that they did not satisfy our OAD criteria, although they did receive an appropriate clinical service. OAD status was confirmed in the remaining 50 patients. That is, (a) all patients had "normal" pure tone sensitivity (pure tone thresholds of less than or equal to 20BHL in each ear for each of the frequencies 0.25, 0.50, 0.75, 1.0, 2.0, 3.0 & 4.0kHz); (b) patients reported significantly greater auditory disability and handicap than controls for a variety of situations (General disability - 7 questions: $t=12.63$; $p<0.0000$; Handicap- 3 questions: $t=9.74$; $p<0.0000$); and (c) none had any obvious cause for their difficulties.

3.4.2.2 Psychoacoustic Factors

(a) Auditory Thresholds

There was a significant difference in the mean pure tone thresholds of the groups (binaural average of all thresholds measured). This was mainly due to a significant difference averaged across frequencies of 0.75, 1.0 & 1.5kHz (AVMID). Average low audiogram (AVLOW) showed marginal group differences, average high audiogram (AVHIGH) did not (Table 3.3 and figure 3.5); the group x audiogram-average interaction was not significant. When a 3-point scale of past or present ear disorder¹ was taken into account with ANCOVA the low- and mid-frequency group differences were not diminished, suggesting their basis does not lie in a conductive component due to ear pathology.

(b) Psychoacoustic Tests

(i) Masked Thresholds

OADs had significantly worse masked thresholds than controls. The group differences remained significant after pure tone threshold at the probe frequency had been accounted for by ANCOVA (500Hz for low-frequency thresholds, 2kHz for mid-frequency thresholds) - Table 3.4

¹This is not the 4-point scale of otological history used elsewhere, but a 3-point scale composed of (i) reported ear disorder in childhood, (ii) reported ear disorder in adulthood, and (iii) reported tinnitus. Reported family history of ear disorder was excluded here as it is likely to have psychological, rather than psychoacoustic influence.

Table 3.3
Means and standard deviations (in brackets) and results of t-tests between OADs and controls for pure tone averages

Variable	Mean threshold (dBHL)		t-value	p<
	OADs	Controls		
AVAUDIO ¹	10.19 (3.7)	8.60 (4.0)	2.07	0.040
AVLOW ²	11.63 (4.2)	9.80 (5.4)	1.91	0.060
AVMID ³	8.65 (4.2)	6.37 (3.9)	2.81	0.006
AVHIGH ⁴	11.00 (4.9)	10.20 (4.9)	0.81	n.s.

- ¹ average of all frequencies measured
- ² average of 125, 250 & 500Hz
- ³ average of 750, 1 & 1.5kHz
- ⁴ average of 3, 4, 6 & 8kHz

Figure 3.5 Average Audiograms of OADs and Matched Controls

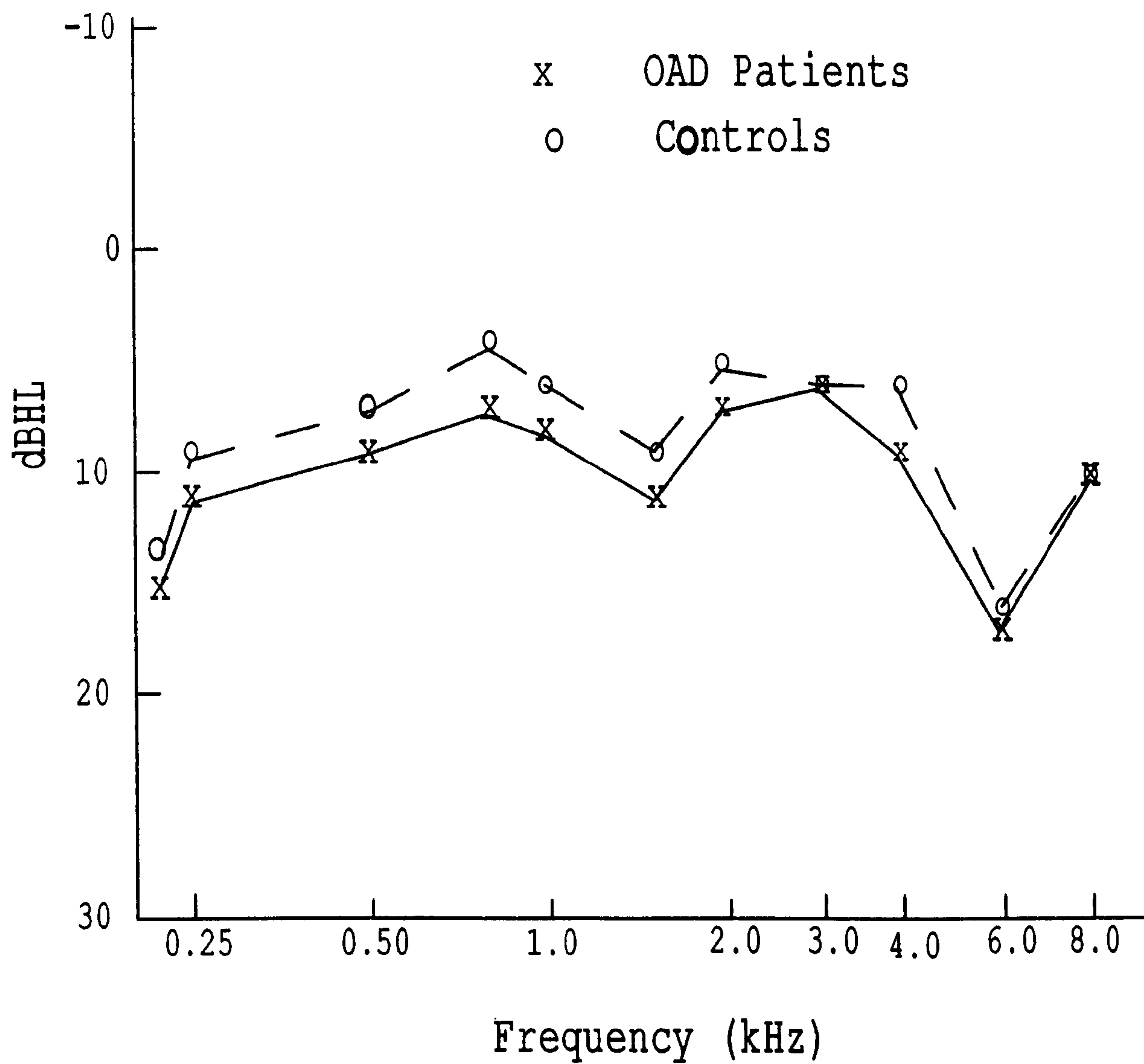

Table 3.4

Adjusted group means and group differences between OADs and controls on masked thresholds (dB attenuation) after ANCOVA accounting for pure tone sensitivity at the probe frequency

Variable	Mean level (dB attn)		F-value	p<
	OADs	Controls		
*Low-freq ¹ (1)	21.2	22.9	14.04	0.0003
*Low-freq ¹ (2)	33.5	35.5	11.90	0.0008
*Mid-freq ² wide-band	30.4	31.7	9.98	0.0030
*Mid-freq ² notch	57.3	59.9	9.16	0.0020

¹Probe tone 500Hz, ²Probe tone 2kHz; *=masked threshold

(ii) Resolution Measures

Patients had marginally worse frequency resolution and significantly worse temporal resolution than controls, but did not differ in the size of their BMLDs. Threshold at the probe frequency was a significant covariate of frequency resolution; group differences were completely removed after ANCOVA. Neither threshold at the probe frequency, nor any other pure tone average, was a significant covariate of temporal resolution (Table 3.5).

Gap thresholds correlated more strongly with peripheral factors among the OAD group than among the control group (Table 3.6). Conversely they correlated more strongly

with central/cognitive factors among the control group than among the OADs (Table 3.11 below). Gap thresholds did not correlate significantly with frequency resolution within either group (OADs: $r=-0.13$, n.s.; Controls: $r=-0.10$, n.s.). Further correlational data between gap thresholds and other variables for OADs and controls combined are presented in tables 6.2 and 6.6.

(c) Evoked Otoacoustic Emissions

There were no differences in any parameters of the evoked acoustic emissions, i.e as a group, OADs had apparently normal emissions present. When more refined analysis techniques are available, perhaps more subtle gradations between EOE's will replace the present dichotomy of normal versus abnormal. Possibly then the present data will reveal group differences.

Table 3.5

Adjusted group means and group differences between OADs and controls on psychoacoustic tests after accounting for pure tone sensitivity at the probe frequency with ANCOVA

Variable	Corrected group mean ¹		F-value	p<
	OADs	Controls		
Frequency (dB resolution attn)	26.9	28.2	2.65	0.110
Temporal resolution (ms)	17.0	13.6	8.58	0.004
BMLD (dB attn)	12.3	12.7	0.76	n.s.

¹For frequency resolution and BMLDs the units are dB attenuation, therefore larger values reflect better ability. For temporal resolution units are gap threshold (ms), therefore smaller values reflect better ability.

Table 3.6
Correlations between gap detection threshold and other
psychoacoustic variables among 50 OADs and among
50 controls. For N=50, $p < 0.05$ if $|r| > 0.27$

Variable correlated with gap thresholds			
	*Mid-freq notch	*Mid-freq. low-pass	PSRTN
Controls	-0.19	-0.28	-0.06
OADs	-0.38	-0.44	-0.31

*=masked threshold

3.4.2.3 Performance Tests

(a) PFFIN

(i) Objective Condition

OADs performed more poorly than controls on the objective condition of the PFFIN test in the presence of both the white noise and babble maskers (PSRTN and PSRTB, respectively) Table 3.7

Two-way ANOVAs showed that OADs' decrement was significantly larger (worse) than that of controls for the PSRTN than for the PSRTB (Group x variable interaction: $F=4.25$, $p<0.04$).

Table 3.7

Mean SRTs in S/N ratio with standard deviations in brackets) and results of t-tests between OADs and controls

TEST	OADs	Controls	t-value	p<
PSRTN	-12.4	-14.9 (3.8)	-3.92 (2.1)	0.0002
PSRTB	-3.1	-4.1 (2.4)	-2.34 (1.3)	0.0020

Accounting for pure tone averages (AVAUDIO or AVLOW or AVMID or AVHIGH), for frequency resolution, for mid-frequency masked thresholds or for BMLDs with ANCOVA did not alter the group differences in PSRTN or PSRTB. However, when gap detection or low-frequency masked thresholds were accounted for by ANCOVA, the above group differences in PSRTN were diminished, and those in PSRTB were removed. Table 3.8 shows adjusted group means and group differences after removing the effects of average audiogram and either gap detection or low-frequency

masked thresholds. Although pure tone thresholds are not directly related to the SRTs, they are related to gap detection and masked thresholds; therefore average audiogram was also used as a covariate.

Table 3.8

Adjusted group means (S/N ratio) and group differences between OADs and controls on the PSRTs after ANCOVA with average audiogram and either low-frequency masked threshold or gap detection threshold

	Partialled variables	Adjusted S/N ratio		F-value	p<
		OADs	controls		
PSRTN	AVAUDIO & low-freq masked threshold	-12.9	-14.3	5.31	0.020
PSRTB		-3.5	-3.7	0.50	n.s.
PSRTN	AVAUDIO & gap detection threshold	-12.9	-14.6	7.21	0.009
PSRTB		-3.4	-3.9	1.15	n.s.

Both anxiety and performance on the dichotic listening test were significant covariates of the PSRTN but not the PSRTB; they both reduced group differences in performance when accounted for by ANCOVA. In contrast, history of otological disorder completely removed group differences on the PSRTB but did not affect them on the PSRTN (Table 3.9). No other cognitive or personality-related covariate affected group differences in performance.

Table 3.9

Adjusted group means (S/N ratio) and group differences between OADs and controls on the performance SRTs after accounting for significant cognitive and personality-related variables with ANCOVA

	Partialled variables	Mean score S/N ratio		F-value	p<
		OADs	controls		
PSRTN	combined dichotic	-12.6	-14.7	11.60	0.001
PSRTN	anxiety	-12.8	-14.6	9.56	0.003
PSRTN	otol history	-12.4	-14.8	13.49	0.000
PSRTB	combined dichotic	-3.2	-4.0	4.49	0.040
PSRTB	anxiety	-3.2	-4.0	4.22	0.040
PSRTB	otol history	-3.4	-3.9	1.90	n.s.

(ii) Subjective Condition

OADs set significantly less adverse S/N ratios than controls for both the self-assessed SRTN and SRTB (SSRTN: $F=58.6$, $p<0.000$; SSRTB: $F=46.2$, $p<0.000$). As with the performance SRTs, two-way ANOVAs showed OADs to have a larger decrement (worse value) compared to controls on the SSRTN than the SSRTB ($F=99.0$, $p<0.0005$). Correcting the self-assessed SRTs for performance SRTs diminished the group differences, but they still remained highly significant. This demonstrates that, as expected, the SSRT is influenced by both actual performance ability and a personality-related factor that influences an individual's judgement of his/her hearing ability. Group differences in this personality-related element were investigated by calculating the PS-Discrepancy (PS-DIS),

subtracting self-assessed ability from actual ability.

(iii) PS-Discrepancy

There were highly significant group differences in the PS-DIS for both noise and babble maskers (PS-DISN and PS-DISB, respectively - Table 3.10) . Average PS-DIS values of controls were almost zero; that is the control subjects' interpretation of the verbal instruction to 'just understand everything' coincides closely with the formal criterion in the adaptive algorithm (50% correct threshold). On the other hand, the average PS-DISN/B values of OADs were positive; that is, OADs set a lower level (less adverse S/N ratio) than that at which they could perform, indicating they were less accurate at estimating their hearing ability, in the direction of underestimating it.

The PS-DISN/B values were derived from the PSRTN/B values and the SSRTN/B values. PSRTs would, therefore, not normally be considered appropriate covariates of the PS-DIS. However, the use of the PSRTs as covariates of the PS-DIS gives an indication of whether the group difference in PS-DIS is performance-based or personality-related. After such an ANCOVA the group difference in PS-DISN/B was increased, rather than diminished, indicating that the group difference is more personality-related than performance-based. No other psychoacoustic variables were significantly related to the PS-DISN/B once PSRTs were taken into account. This implies that actual performance reflects psychoacoustic

Table 3.10

Mean group values of the PS-Discrepancy, standard deviations (in brackets) and results of t-tests between OADs and controls

Test	Objective-subjective attenuation difference		t-value	p<
	OADs	Controls		
PS-DISN	3.56 (4.42)	-0.71 (3.68)	5.25	0.0000
PS-DISB	2.87 (2.01)	0.60 (1.63)	6.15	0.0000

effects upon the PS-DIS. Scores on the dichotic listening test were significantly related to the PS-DISN, and as above, group differences were increased, rather than diminished, when performance on either the focussed or divided attention condition was taken into account. No other cognitive or personality-related variable was significantly related to the PS-DISN or PS-DISB. The fact that group differences in PS-DIS are not diminished, but enhanced when performance and psychoacoustic variables are accounted for by ANCOVA shows that the degree of mis-judgement of hearing among OADs is greater than would be expected from subtle associations with sensory factors that might arise through poor speech-in-noise discrimination.

(b) Band-filtered FAAF Test in Quiet

OADs had significantly lower overall scores on the FAAF test (speech-in-quiet) than controls (OADs: 76.9%, Controls: 79.7%, $F=3.95$, $p<0.05$). None of the audiogram

averages were significant covariates of the FAAF score. However, low-frequency and mid-frequency (low-pass) masked thresholds were significant covariates, as was the gap detection threshold and scores on all both conditions the dichotic test; in each case the group difference was diminished to non-significance when these variables were taken into account alone.

(c) Audiovisual Test

OADs performed significantly more poorly than controls on the audio-visual SRTN (VSRTN) and on the auditory alone SRTN (ASRTN) from the same test, although not on the lipreading variable derived by differencing them (VSRTN: $t = -2.21$, $p < 0.03$; SRTN: $t = -2.59$, $p < 0.01$; Lipreading: $t = 0.05$, n.s.). Since the group deficit for OADs was no larger for the VSRTN than for the SRTN (the t -value was actually lower), lipreading is clearly not a major factor in OAD.

3.4.2.4 Central/Cognitive Tests

(a) Dichotic Listening Test

(i) Focussed versus Divided Conditions

OAD patients scored less well on the focussed attention condition (left and right ears combined) of the dichotic listening test than did controls; but there was no difference in performance on the divided attention condition (Focussed: $t = -2.63$, $p < 0.01$; divided: $t = -0.87$, n.s.). The corresponding group x condition interaction

was not significant. Group difference in performance on the focussed condition was diminished, but remained significant when gap detection was accounted for with ANCOVA; it was completely removed when the occurrence of childhood reading/writing difficulties was partialled.

(ii) Ear Advantages

The control group showed significant right ear advantages (REA) for overall performance - combining scores from the focussed and divided conditions ($t=2.55$, $p<0.01$), and for right ear report during the divided attention condition ($t=3.46$, $p<0.001$). OADs did not show an REA for the former condition, but did for the latter ($t=3.26$, $p<0.002$). The group x REA interaction was not significant, although there was a slight trend for controls to show greater REAs than OADs.

(b) Sentence Monitoring Test

There were no significant differences in raw reaction times on any condition of the sentence-monitoring test, nor on the variable combining reaction times from all three conditions, nor on the derived variables of reaction time differences between conditions. However, there were significant differences in reaction times between the predictable, unpredictable and nonsense conditions for both groups; i.e the test conditions were sufficiently reliable as to show between-condition differences (appendix 3.10).

(c) Cognition-Related Factors from the Interview

More OADs reported having had reading/writing difficulties as children than controls ($X^2=8.3$, $p<0.004$), and more reported cardiovascular and respiratory illnesses than controls ($X^2=3.7$, $p<0.05$). There were no more OADs who were regular smokers than controls, nor did OADs have a greater history of exposure to toxic fumes. The basis for classifying the latter three factors as 'cognition-related' came from work by Cunningham et al (1987), (see section 1.2.1.2).

Central/cognitive factors correlated more strongly with gap detection thresholds within the control group than within the OAD group (table 3.11). This is in direct contrast to the relationship between gap thresholds and peripheral factors (table 3.6, above).

Table 3.11
Correlations between central/cognitive variables and gap detection thresholds among 50 OADs and among 50 controls. For $|r| > 0.27$, $p < 0.05$

	Variable correlated with gap thresholds		
	Reading/writing difficulties	Focussed attn	Divided attn
Controls	0.56	-0.35	-0.44
OADs	0.35	-0.15	-0.19

3.4.2.5 Personality-Related Factors

(a) Crown-Crisp Questionnaire

OADs had marginally higher scores than controls on the phobic anxiety scale and obsessive scale than controls (Phobic scale: $t=1.91$, $p<0.06$; Obsessive scale: $t=1.72$, $p<0.09$). On the combined scale of general anxiety, phobic anxiety and somatic anxiety, OADs and controls differed at only the $p<0.1$ level of significance, with OADs having the higher ratings.

(b) Health Beliefs

There were no group differences on the preventive health scale (from the OAD interview), nor in replies to the question 'do you tend to worry about your health' (also from the interview). General over-concern about health does not, therefore, seem to be an important factor.

3.4.2.6 Factors Associated with a History of Ear Disorder

More OADs than controls mentioned experiencing tinnitus ($\chi^2=8.4$, $p<0.004$), and having a family member with hearing problems ($\chi^2=5.8$, $p<0.020$); but OADs did not report having experienced ear disorder in childhood or adulthood more frequently. On the 4-point combined scale of otological history (combining past and present ear disorder, familial history and tinnitus) OADs had marginally higher ratings ($\chi^2=9.0$, $p<0.060$).

3.4.2.7 Reported Auditory Disability and Handicap

As mentioned in the section confirming OAD status (1 above), OADs reported significantly greater auditory disability and handicap than controls. Performance SRTs, anxiety level, and educational level were all significant covariates of self-reported disability. However after partialling for the effects of these variables, both individually and combined, the group difference in reported disability remained very highly significant. (Reported disability after removing the combined effects of PSRTN, anxiety and educational level with ANCOVA: $F=71.3$, $p<0.000$). The only significant covariate of self-reported handicap was anxiety level, but again after partialling for anxiety, the group difference remained highly significant (Reported handicap after removing the effects of anxiety level with ANCOVA: $F=154.5$, $p<0.000$).

3.4.3 MULTIVARIATE ANALYSES

Univariate analyses demonstrated that patients differed from controls on many types of variable, confirming that a broadly appropriate set was developed from stage I. However, such analyses give little information about the relative importance of each variable in explaining the basis of OAD, nor of the minimum or optimum set of variables distinguishing the OADs from controls. Multivariate analysis is a more appropriate tool for doing this, because it determines combinations of independent variables that explain the variance in a dependent variable, taking into account inter-correlations between the independent variables.

Specifically, multivariate analyses were used to learn (a) what clusters of variables best differentiated OADs from controls, and (b), what factors influenced the performance of OAD patients upon these differentiating variables.

3.4.3.1 Modelling using the whole OAD Group

3.4.3.1.1 Accounting for OAD Status

Logistic regression analysis was used to determine the combination of factors differentiating OADs from controls, i.e to determine the factors best describing OAD status. Logistic regression, like multiple linear regression, determines the set of independent variables that best explain or predict the deviance (variance) in a dependent variable. As the variable of OAD versus control is binary, not continuous, the logistic version of regression was required. Discriminant function analysis (DFA) was then used to determine the classification matrix (i.e the numbers of patients and controls correctly classified as patients or controls by the independent variables¹). This provided an index for comparison of how well the independent variables jointly distinguished the two groups by maximising the ratio of between-group to within-group variance. Although the statistical procedure for determining the discriminant function differs from that determining the regression

¹In all analyses identical independent variables were entered into the regression and discriminant function analyses.

equation, and is in a sense less sensitive, its classification matrices are easy to understand. They are presented here as useful supplements to the information provided by the regression analysis, in particular when comparing between analyses, even though the percent correct classification is an underestimate. All tables presenting results of OAD status description contain both the logistic regression and DFA results. Logistic regression results are presented first. Column 1 lists the independent variables in the order they entered the step-wise regression; column 2 gives the additional percentage of the group deviance explained by that variable; column 3 shows the significance of the variable on entry; and column 4 gives the regression coefficient of that variable in the final equation. Patients are coded as 0, controls are coded as 1, therefore a positive regression coefficient denotes that controls have a higher value on the test variable in question. High values on masked thresholds, frequency resolution, the BMLD and on the PSRTN indicate good performance. Low values on gap detection and average audiogram indicate good performance, and a low value on the PS-DIS indicates accurate estimation of hearing ability. Following the logistic regression results, in the same table, the classification matrix from DFA is presented. Only those variables that entered the logistic regression equation with a significance of $p \leq 0.05$ are included in the results tables.

In order to decide which of the many possible independent variables to enter into the final regression analysis, three types of preliminary analyses were done. Preliminary analysis 1 determined the psychoacoustic variables that best differentiated OADs from controls. Preliminary analysis 2 determined the main cognitive

variables, and preliminary analysis 3 determined the most important personality-related variables. (See tables 3.12a,b and c below.) A fourth preliminary analysis was carried out to determine which performance measure best differentiated the two groups. (See table 3.12d.) These preliminary analyses seemed logically the best way to deal with the large number of variables potentially available for inclusion in the final analysis. It is acknowledged that some variables could have been excluded from the final analysis on the basis that they did not explain OAD status in their own right, but they could still have contributed in conjunction with a variable from a different domain. However, it is unlikely that any important factor was missed given that when an analysis was done using all possible variables, the first four to enter the regression equation were the same as those that entered the final equation in table 3.13. In addition, one variable from each domain entered (i.e the contributions from each domain are independent of one another) and variables from each domain act independently upon status (table 3.14).

Table 3.12

Account of OAD status using logistic regression
and discriminant function analysis

(a) Preliminary Analysis 1 - All Psychoacoustic
Variables

Variable entering equation	% total deviance explained	Significance of variable at entry	Regression coefficient
Low-freq. masked thresh	13.5	0.000	-0.352
Mid-freq notch masked thresh.	5.1	0.008	-0.145

TOTAL: 18.6%

Classification Matrix:

	OADs	CONTROLS
OADs	60%	40%
CONTROLS	26%	74%

(b) Preliminary Analysis 2 - All Cognitive Variables

Variable entering equation	% total deviance explained	Significance of variable at entry	Regression coefficient
Focussed attention	5.0	0.01	-0.006

TOTAL: 5.0%

Classification Matrix:

	OADs	CONTROLS
OADs	46%	54%
CONTROLS	28%	72%

(c) Preliminary Analysis 3 - All Personality-related Variables

PS-DIS	17.8	0.000	0.278
¹ Somatic	3.8	0.040	0.278

TOTAL: 21.6%

Classification Matrix:

	OADs	CONTROLS
OADs	74%	26%
CONTROLS	70%	30%

¹A 9-point scale from the OAD interview

(d) Preliminary Analysis 4 - All Performance Variables

Variable entering equation	% total deviance explained	Significance of variable at entry	Regression coefficient
PSRTN	10.4	0.000	-0.314
TOTAL	10.4%		

Classification Matrix:

	OADs	CONTROLS
OADs	60%	40%
CONTROLS	42%	58%

The preliminary analyses showed that at least one independent variable from each domain played a role in explaining OAD status, although some of these were weak.

The final account of OAD status was run with all variables that entered the preliminary analyses. The total explained in this analysis is close to the sum of that explained by individual preliminary analyses (table 3.13). This is further evidence that contributions from each domain are independent. The most important single set of findings in this thesis is that in table 3.13.

Table 3.13

Account of OAD Status with logistic regression and discriminant function analysis using variables from each domain.

Final account of status

Variable entering equation	% total deviance explained	Significance of variable at entry	Regression coefficient
PS-DIS	17.8	0.000	0.477
PSRTN	19.6	0.000	-0.463
Focussed attention	6.5	0.003	-0.114
Mid-freq notch masked thresh.	5.9	0.004	-0.224

TOTAL: 49.8%

Classification Matrix:

	OADs	CONTROLS
OADs	80%	20%
CONTROLS	10%	90%

The combined explanatory effect of the variables 'PSRTN' and 'PS-DISN' would be equivalent to that of the single variable 'SSRTN' as it is logically equivalent to the other two. However by using the pair of variables in the analysis, rather than the single variable, information is gained about the relative importance of psychoacoustic/cognitive factors, as compared with personality-related factors in OAD (represented by the

PSRTN and PS-DISN respectively). This information would not have been available had only the SSRTN been entered.

Self-rated disability/handicap scores were not included in the analysis to account for OAD status because they are almost equivalent to a definition of OAD. This is evidenced by the high correlation between OAD status and self-rated disability/handicap (Correlation of status with self-rated disability: $r=-0.70$; with self-rated handicap: $r=-0.79$). The deviance explained would clearly have been greater had the account of status included these variables. But as they essentially reflect the patient's own definition of the problem, the result would not have given a greater understanding of the basis of the problem.

Table 3.14 shows raw correlations of OAD status with each of the variables that entered the final logistic regression to account for OAD status. All correlations have the same sign as the regression coefficients. This shows that each variable contributes directly to OAD status, and that the role of each variable is fairly independent of others in the equation.

Table 3.14

Table of raw correlations of OAD status with the four variables best differentiating OADs from controls. For $n=100$, $p>0.05$ if $|r|0.195$.

Variable	r	p<
PS-DIS	-0.47	0.001
PSRTN	0.37	0.001
Focussed attention	0.34	0.001
*Mid-freq. notch	0.26	0.001

*=masked threshold

One psychoacoustic variable (the low-frequency masked threshold) and one personality-related variable (somatic anxiety) that entered the preliminary analyses dropped out of the final equation, because their roles had been preempted by other variables.

In summary, OAD status was determined by a combination of psychoacoustic, cognitive, personality-related and performance variables. Of the variables measured, the best combination was that of poorer masked thresholds (psychoacoustic), poorer ability to direct attention appropriately (cognitive), incorrect assessment (underestimation) of own hearing ability (personality-related) and poorer ability to hear speech-in-white noise (performance).

3.4.3.1.2 Modelling of the PSRTN and PS-DIS

Description of OAD status established the factors most important in differentiating OADs from controls. Following this, it was important to learn what factors determined OAD patients' performance upon these differentiating variables. In particular, to learn what factors determined actual scores on the PSRTN and the PS-DISN, since these variables were the most important descriptors of OAD status. Multiple linear regression was used for this purpose. Preliminary analyses determining which independent variables to use in the final regressions of the PSRTN and PS-DISN were carried out (as in the preliminary analyses above for status description). An additional preliminary analysis was done to learn whether any socio-demographic matching variable(s) also played a role in determining PSRTN and PS-DISN values. Table 3.15 shows results of the final multiple linear regressions. Variables listed make a significant contribution (at $p < 0.05$) to explaining the total variance.

Table 3.15

Modelling of PSRTN and PS-Discrepancy using multiple linear regression (N=50 OAD patients)

DEPENDENT VARIABLE PSRTN			DEPENDENT VARIABLE PS-DISN		
Variable	Adj. R ² change	Regn Coeffic.	Variable	Adj. R ² change	Regn Coeffic.
*Low-freq.	0.23	0.38	Focused attention	0.11	0.36
Sex of subject	0.07	-0.31			
TOTAL: 0.30			TOTAL: 0.11		

*=masked threshold

In total, only 30% of the within-group variance in PSRTN, and 11% of the variance in PS-DISN was explained in these analyses. The variables explaining a significant amount of the variance in PSRTN were the low-frequency masked threshold and sex; they explained 23% and 7%, respectively. Sex has a negative coefficient, implying that men (coded as 1) perform better than women (coded as 2). The focussed attention variable was the only variable to explain a significant amount of the variance in PS-DIS; it explained 11%. This low accountability of the variance could be due to one of three things: (i) none of the other variables in the stage II test battery relate to either the PSRTN or PS-DISN; (ii) the PSRTN and PS-DISN tests are unreliable; or (iii) in the whole OAD population there exist sub-groups, within which performance on the PSRTN and PS-DIS is determined by

similar factors, but between which the factors differ. In view of there being correlations between the PSRTN, PS-DISN and other variables (see tables 6.6, 6.8 and 6.9), the former explanations seemed unlikely. Accordingly the latter explanation was further investigated.

3.4.3.2 Modelling using Possible OAD Sub-Groups

The OAD population was divided into sub-groups on a variety of dichotomies, each of which could have potentially been useful in clinical practice (see section 3.6.2). The population was therefore dichotomised by age, sex, pure tone sensitivity, noise exposure history (no exposure versus some exposure) and on the PFFIN (good versus poor performance). While dichotomisation might not give the optimum division for the actual variance structure, it enables the sample sizes within each sub-group to remain large enough to avoid unreliability. For division by a continuous variable (age and pure tone sensitivity) the cut-point was, therefore, located as near to the 50th percentile as the actual distribution permitted. This maximised statistical efficiency without greatly diminishing statistical validity. The findings presented are from sub-division by age and by pure tone sensitivity, because these sub-divisions gave the greatest increases in variance explained in the final models over that for the group as a whole. The variance explained by the models after division by sex and noise exposure was not substantially increased. In 2.4.3 it was postulated that OADs with a performance deficit might differ from those without a deficit. However the models of OAD status, PSRTN and PS-DIS did not explain substantially more of the total variance than that

explained for the group as a whole.

3.4.3.2.1 Accounting for OAD Status within Sub-Groups

First, logistic regression and DFA were used to account for OAD status of patients and their matched-controls within each sub-group. Preliminary analyses, analogous to those in tables 3.12a,b,c and d above, were carried out before the final analyses. These revealed that the variables describing OAD status within each of the sub-groups were, in the main, the same as those describing status among the group as a whole (tables 3.16a & b). The PSRTN and PS-DISN entered the regression equation in all four final analyses, the measure of focussed attention ability entered the equation in three of the four, and the mid-frequency masked threshold entered the equation in two of the four. There were just two instances in which additional variables entered the equations: (a) within the worse-hearing sub-group, gap-detection ability entered in addition to the other four variables, although it only explained a further 3.9% of the group deviance; (b) in the older sub-group somatic anxiety entered the equation in addition to the PSRTN and PS-DISN, explaining 7.4% of the group deviance.

Table 3.16a(i)

Accounting for OAD status with multiple logistic regression within the better-hearing OAD sub-group

(i) Better-hearing sub-group (n=26, AVAUDIO<=10dBHL)

Variable entering equation	% total variance explained	Significance of variable at entry	Regression coefficient
PS-DIS	14.4	0.008	0.382
Focussed attention	18.6	0.003	-0.161
PSRTN	6.4	0.050	-0.316

TOTAL: 39.4%

Classification Matrix:

	OADs	CONTROLS
OADs	77%	23%
CONTROLS	19%	81%

Table 3.16a(ii)

Accounting for OAD status with multiple logistic regression within the worse-hearing OAD sub-group

(ii) Worse-hearing sub-group (n=24, AVAUDIO>10dBHL)

Variable entering equation	% total variance explained	Significance of variable at entry	Regression coefficient
PS-DISN	24.3	0.003	1.07
PSRTN	25.5	0.001	-0.892
*Mid-freq. notch	8.0	0.050	-0.597
Focussed attention	8.4	0.020	-0.229
Gap threshold	3.9	0.030	-0.262

TOTAL: 70.1%

Classification Matrix:

	OADs	CONTROLS
OADs	83%	17%
CONTROLS	17%	83%

*=masked threshold

Table 3.16b(i)

Accounting for OAD status with multiple logistic regression within the young OAD sub-group

(a) Young sub-group (n=24, <=32 years)

Variable entering equation	% total deviance explained	Significance of variable at entry	Regression coefficient
PS-DIS	17.5	0.005	0.326
PSRTN	18.9	0.003	-0.383
¹ Somatic anxiety	7.5	0.030	0.695

TOTAL: 43.9%

Classification Matrix:

	OADs	CONTROLS
OADs	73%	27%
CONTROLS	23%	77%

¹9-point scale from the Interview

Table 3.16b(ii)

Accounting for OAD status with multiple logistic regression within the older OAD sub-group

(b) Old sub-group (n=26, >32 years)

Variable entering equation	% total deviance explained	Significance of variable at entry	Regression coefficient
PS-DIS	18.9	0.001	0.924
Focussed attention	23.1	0.003	-0.451
PSRTN	16.5	0.004	-0.713
*Mid-freq.	11.1	0.030	-0.487

TOTAL: 69.6%

Classification Matrix:

	OADs	CONTROLS
OADs	83%	17%
CONTROLS	17%	83%

*=masked threshold

A considerably more accurate account of OAD status was obtained within the worse-hearing and older sub-groups than within the group as a whole (70.1% and 69.6% group deviance explained respectively, as compared to 49.8%). In the better-hearing and younger sub-groups slightly less group deviance was explained than for the group as a whole (39.4% and 43.9% respectively). Identical numbers of cases were correctly classified by DFA as for the group as a whole, when numbers from both sub-groups were totalled. There was inevitably a loss of reliability in the results for the small sub-groups, as compared with the results for the group as a whole, but there is no precise way to quantify this. Nevertheless, taking the results at face value, comparison of the results from all sets of analyses suggests that, when accounting for OAD status, there is only slight benefit to be gained from sub-dividing the population. The main determinants of OAD status remain fairly stable across age and pure tone sensitivity, although, when dealing with a particularly old or marginally-impaired individual there may be some benefit in using the results gained after the appropriate sub-division.

3.4.3.2.2 Modelling of the PSRTN and PS-DIS within the OAD Sub-Groups

The independent variables that determined actual scores on the PSRTN and PS-DISN were next modelled for OADs within each of the four sub-groups, using multiple linear regression. Once again, prior to final analysis, preliminary analyses were used to determine the set of independent variables to enter into the final analysis. Tables 3.17a & b show results of the final analyses for

modelling of the PSRTN within the four sub-groups of the OAD population. Tables 3.18a & b show the results for modelling the PS-DISN.

Table 3.17a
Modelling of the PSRTN with multiple linear regression for OAD patients with good (10dBHL, N=26) versus poor 10dBHL, N=24) pure tone sensitivity.

Average audiogram <=10dB

Average audiogram >10dB

Variable	Adj.R ² change	Regn Coeffic.	Variable	Adj.R ² change	Regn Coeffic.
*Low-freq.	0.48	0.80	BMLD	0.10 (n.s.)	0.37
Average audiogram	0.12	0.38			
TOTAL: 0.60			TOTAL: 0.10		

Table 3.17b
Modelling of PSRTN with multiple linear regression among young age<=32, N=24) versus old (age >32, N=26) OAD patients

Young patients

Older patients

BMLD	0.52	0.57	Sex of subject	0.37	-0.63
*Low-freq.	0.15	0.43			
TOTAL: 0.67			TOTAL: 0.37		

*Masked Threshold

Table 3.18a

Modelling of the PS-DIS with multiple linear regression for OAD patients with good (10dBHL, N=26) versus poor (10dBHL, N=24) pure tone sensitivity.

Average audiogram <= 10dBHL

Average audiogram >10dBHL

Variable	Adj.R ² change	Regn Coeffic.	Variable	Adj.R ² change	Regn Coeffic.
*Low-freq.	0.11	0.56	Focussed attention	0.32	-0.34
Gap threshold	0.16	0.46	Sex of subject	0.12	0.38

TOTAL: 0.27

TOTAL: 0.44

Table 3.18b

Modelling of PSRTN with multiple linear regression among young (age<=32, N=24) versus old (age >32, N=26) OAD patients

Young patients

Old patients

Otological history	0.20	0.48	Focussed attention	0.27	0.55
--------------------	------	------	--------------------	------	------

TOTAL: 0.20

TOTAL: 0.27

*Masked Threshold

Within the better-hearing sub-group and the younger sub-group the variance explained in the model for the PSRTN was considerably greater than within the group as a whole (60% and 67% group deviance explained respectively, as compared with 30% within the whole group). Within the older sub-group the variance explained by the model for

the PSRTN was marginally improved (37%), and within the worse-hearing sub-group it diminished (10%). The variables in the model for both the better-hearing and worse-hearing sub-groups, and for the younger sub-group were of psychoacoustic nature. In section 3.6.2.2.1(b) a probable explanation for the paradoxically positive regression coefficient of average audiogram in the model for the better-hearing sub-group is discussed. Within the older sub-group the only variable significantly explaining the group variance was the sex of the individual. It had a positive coefficient, implying that older men have poorer performance than older women.

The models of the PS-DISN in all four sub-groups were substantially better in terms of the variance explained than for the group as a whole. This was particularly so within the worse-hearing sub-group (better-hearing: 27%, worse-hearing: 44%, younger: 20%, older: 27%, as compared with 11% for within the group as a whole). Psychoacoustic variables entered the model for the better-hearing sub-group, while a central measure and the sex of the individual entered for the worse-hearing sub-group. Here sex had a positive coefficient, implying that worse-hearing women underestimate their hearing to a greater extent than worse-hearing men. In the younger sub-group, otological history entered the model, while a central/cognitive variable entered for the older sub-group.

It is of interest to note that sex, one of the variables on which controls were matched, entered the models of the PSRTN and PS-DIS in three final analyses. This illustrates the importance of having matched on sex when accounting for OAD status.

To summarise, performance on the PSRTN and PS-DIS was improved after sub-division by pure tone sensitivity and by the age of an individual, as evidenced by the models explaining more of the total variance (in 7 of 8 instances) after sub-division by one of these factors.

3.5 DISCUSSION

3.5.1 DISCUSSION OF UNIVARIATE ANALYSES

3.5.1.1 Determinants of OAD Status

As in stage I, OADs performed less well than controls on the speech-in-noise test. This presumably explains in part their reported auditory disability and handicap. However, ANCOVA using the performance SRTs as covariates shows that the disability/handicap reported by patients is far from being explicable by their performance deficit.

3.5.1.2 Psychoacoustic Factors

(a) Pure Tone Sensitivity

Although within conventionally defined 'normal limits', the average audiogram of patients was significantly higher than that of controls, the difference between the average audiogram of the groups is 2dB. This minor difference is not sufficient to explain patients'

perceived disability, as confirmed by accounting for pure tone sensitivity. The basis of OAD in some patients with thresholds on the margin of normality (i.e those who just qualify for inclusion in the study) might lie largely in psychoacoustic factors of which pure tone sensitivity is an imperfect reflection. This notion is further discussed in section 6.2.1. sp 2 Pure tone sensitivity of the groups differed more at low- and mid-frequencies than at high-frequencies, although these group x frequency interactions were not significant. The tendency is slightly surprising, however, because thresholds at high-frequencies (above 4kHz) are known to deteriorate before those at low-frequencies with both age (Robinson & Sutton, 1979), and noise exposure (Taylor et al, 1965). Marginal pathology associated with one or both of these factors was a plausible explanation of OAD (Pick & Evans, 1983). However, the results imply that neither early onset of deterioration, nor noise-induced hearing loss is the basis of OAD. Mild conductive loss due to childhood or adult otological pathology is not a satisfactory explanation for the comparatively larger low- and mid-frequency loss among the OADs, since ANCOVA correcting for otological disorder did not diminish the group differences significantly.

In stage I there was a marginal group difference in average audiogram ($p < 0.08$), and in average low- and average high-frequency audiograms ($p < 0.06$ and $p < 0.05$, respectively), while thresholds at 250Hz and 3kHz were significantly different ($p < 0.02$ for both). The findings of stage II are generally in close agreement. The slightly more stringent criteria used for inclusion in

stage II¹ of the study probably explains why there was no group difference in the high-frequency average in stage II.

(b) Masked Thresholds

ANCOVA showed that group differences in masked thresholds were partly mediated through pure tone sensitivity, although after sensitivity was taken into account with ANCOVA the group differences did remain significant. The masked threshold measures a combination of frequency resolution and random physiological noise in the auditory system. Their resultant effects are the same (to decrease the detectability of a tone in noise) but their physiological bases are different. Of the four raw masked thresholds measured, the mid-frequency notch condition is weighted more toward a measure of frequency resolution *per se* than the other three. The group difference on this masked threshold is less than that for the other three. For this reason, and because frequency resolution (calculated from the mid-frequency masked thresholds) was a non-significant covariate of the low-frequency masked thresholds, it appears that the internal noise component of the masked threshold had a greater influence upon the group differences than the frequency resolution component. It should be noted, however, that frequency resolution was measured at 2kHz, while the low-frequency masked thresholds were measured at 500Hz. Patterson et al (1982) pointed out that the internal S/N ratio is an important determinant of masked thresholds.

¹In stage II no individual had thresholds of >30dB at 6 & 8kHz, in stage I 20% of individuals did have thresholds >30dB at 6 and/or 8kHz.

Frequency resolution *per se* cannot be completely ruled out as a factor in OAD, given the findings that (a) there were group differences in frequency resolution ability (see next section) and (b) the mid-frequency notch condition masked threshold entered the logistic regression equation accounting for status, as opposed to the mid-frequency low-pass condition (table 3.13, above). Thus frequency resolution does play a role in OAD, although this role is by no means major.

In stage I no group differences were found in on- or off-frequency masked thresholds for a probe tone of 2kHz. One reason for these contradictory results might be because during stage I some test equipment was unreliable and hence, possibly, the data also.

(c) Frequency Resolution

OADs had worse frequency resolution than controls. This is consistent with suggestions from less well controlled studies using patients comparable to OADs (Pick & Evans, 1983; Narula & Mason, 1988; Earl et al, 1987). However, the presence of many group differences in each of the domains investigated, demonstrates that minor auditory dysfunction in the form of poor frequency resolution is by no means the only, or even a major factor in explaining OAD. Such a proposition would leave the group inadequately characterised. The unifactorial explanation originally proposed by Pick & Evans (1983) and Narula & Mason (1988) probably arose because they only tested a unifactorial hypothesis.

In stage I there were no group differences in frequency resolution ability. The use of the notched noise

technique rather than measurement of a PTC might in part explain these contradictory findings. In the introduction to this chapter the relative merits of using the notched-noise technique over the PTC method were discussed. In particular it pointed out that the PTC method does not take into account the effects of off-frequency listening, nor the possibility that the internal S/N ratio might differ when listening through an off-frequency filter. As applied to this situation, in which a poorer internal S/N ratio was shown to differentiate OADs from controls, the use of the PTC technique for frequency resolution would place OADs at a greater disadvantage relative to controls, since controls could make use of off-frequency listening and a comparatively advantageous internal S/N ratio. From this it would follow that OADs would show comparatively worse frequency resolution when measured with the PTC method (stage I) as compared to the notched-noise technique (stage II). The opposite was in fact found. It must be concluded that either measurement during stage I was less well made, or that the PTC and notched-noise techniques measure somewhat different processes. One study reporting correlations between these two measures (Tuplin, 1985) showed that only the upward spread of masking measure from the PTC correlated with notched noise results. In stage I, however, upward spread of masking was not more sensitive to group differences, nor did it correlate better with other variables than downward spread of masking.

(d) Temporal Resolution

The difference between OADs and controls in temporal resolution ability is highly significant. Gap detection scores among the OAD group correlate significantly with peripheral factors (masked thresholds, and performance), but less well with central/cognitive factors (reading and writing difficulties as a child, dichotic scores); the converse relationship was found among the control group. This suggests that gap detection in the OAD group is mediated, and hence limited, to a greater extent by peripheral auditory dysfunction than it is among the control group. The absence of a correlation between frequency resolution and gap detection within both groups does not enable these results to be interpreted in terms of widened auditory filters facilitating gap detection.

(e) Binaural Masking Level Differences (BMLDs)

The null finding of a group difference in BMLDs is surprising in view of the work of Earl et al (1987). They report that their OAD-like subjects had significantly poorer BMLDs at 250, 500 and 1000Hz and that discriminant function analysis distinguished the OAD-like group from controls on the basis of BMLDs and masking measures akin to frequency resolution. The explanation for this discrepancy might lie in one or more of the following bases. First, the reliability correlations for replicates of the BMLD in this study range from 0.58 (for controls) to 0.75 (for OADs); these are moderate values, probably because subjects were not trained before testing. Earl et al do not mention reliability correlations nor whether subjects underwent training prior to testing. However, in view of the narrow and specialised psychoacoustic test

battery, it is likely that their subjects were better trained, and hence their results more reliable. Secondly, the most significant BMLD group difference in Earl et al's study was that at 1000Hz ($p < 0.0000$), while the BMLD values that entered their discriminant function analyses were those at 1000Hz and 250Hz. In this study the BMLD was measured only at 500Hz - the frequency having least importance in Earl et al's work. Finally, unlike OADs, none of the individuals in Earl et al's study had sought clinical attention for their hearing. Personality-related factors play a major role in determining whether or not an individual seeks medical attention for a given symptom, and so it is important to consider this when comparing the two studies. Some of the factors differentiating OADs from controls, are therefore likely (and indeed have been shown) to be personality-related. In Earl et al's study these factors would be absent, so reported difficulties are more likely to be of a psychoacoustic nature.

(f) Evoked Otoacoustic Emissions

The group differences on many psychoacoustic variables demonstrates that to a degree OAD patients as a group have minor peripheral auditory dysfunction. However, the absence of differences on all parameters derived from the EOE data suggests the peripheral dysfunction in the OAD group is too minor to be detected by EOE's. This null finding suggests that peripheral dysfunction, at the level detectable by EOE's, cannot be the major cause of OAD.

3.5.1.3 Performance Tests

(a) PFFIN Test

(i) Objective Condition

ANOVAs show that OADs have a genuine performance deficit and hence a measurable basis for their complaints, on both the PSRTN and PSRTB. This study, and those of Pick & Evans (1983), Earl et al (1987) and Narula & Mason (1988), found OAD patients to have minor psychoacoustic deficits. These should be reflected in a performance deficit; in this study they were. The null findings of the latter three studies, probably reflect insensitive performance tests. The degree of measured deficit, however, is too small to fully explain patients' reported disability/handicap. It seems that a personality-related element has a major influence upon the reporting of symptoms by OADs. ANCOVAs showed the poorer PSRTN and PSRTB were in part due to minor peripheral auditory dysfunction, in the form of poor masked thresholds and poor gap-detection ability. Also, the PSRTN was influenced by a central processing factor (ability on the dichotic listening test) and a personality-related factor (anxiety level), while the PSRTB was influenced by a history of otological disorder. The central factor probably reflects a limited capacity for processing under difficult conditions (Kahneman, 1973). It probably did not play a role in explaining the group differences in PSRTB because the babble masker is a very effective peripheral masker, and hence the effects of subtle central deficits would not be seen. However, in the white noise masked condition (PSRTN), where less peripheral masking is occurring, minor central deficits would be measurable. A similar explanation might hold for the

finding that anxiety was a significant covariate of the PSRTN but not the PSRTB. On the other hand, otological history was a significant covariate of the PSRTB and not the PSRTN. A history of otological disorder might be associated with generally poorer peripheral function, and, hence might compound the masking effects of babble.

OADs performed more poorly than controls on the PSRTN than the PSRTB. This is probably related to the masking function of the white-noise as compared with the speech-shaped babble. White noise has a uniform spectrum level at all frequencies, while speech-shaped noise (and of course speech itself) has more energy in the low frequencies. Figure 3.6 gives a graphic representation. This, and because auditory filters are wider at higher frequencies, causes most high-frequency speech energy to be masked in the presence of white noise, leaving only some low-frequency information available. In the presence of a speech-shaped masker, all speech frequencies are masked to an equal extent. OADs are known to have relatively poorer hearing than controls at low- to mid-frequencies. In terms of both acuity and frequency resolution ability these are the frequencies required for the processing of speech in the presence of white-noise. It is therefore not surprising that OADs are relatively worse than controls on the PSRTN as compared with the PSRTB. This explanation is supported by the finding that accounting for average low-frequency audiogram with ANCOVA significantly diminishes the group difference in PSRTN but not the PSRTB.

Most importantly, the objective PFFIN test has shown that OADs do have a measurable basis for their reported auditory disability and handicap, even though their complaints are out of proportion to the actual deficit.

Figure 3.6 Representation of the Differential Effects of Masking Speech with White Noise versus Speech-Shaped Noise

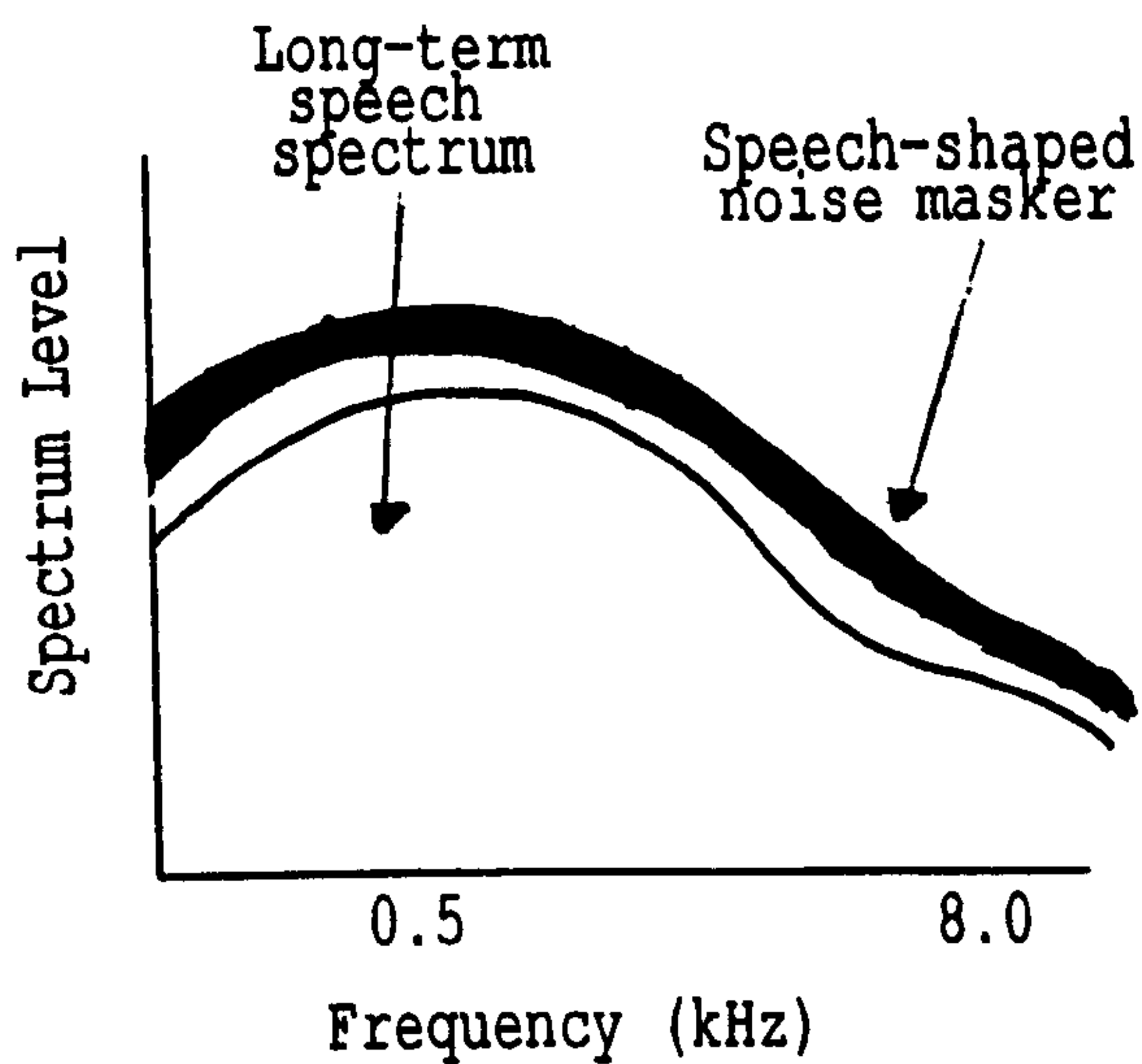
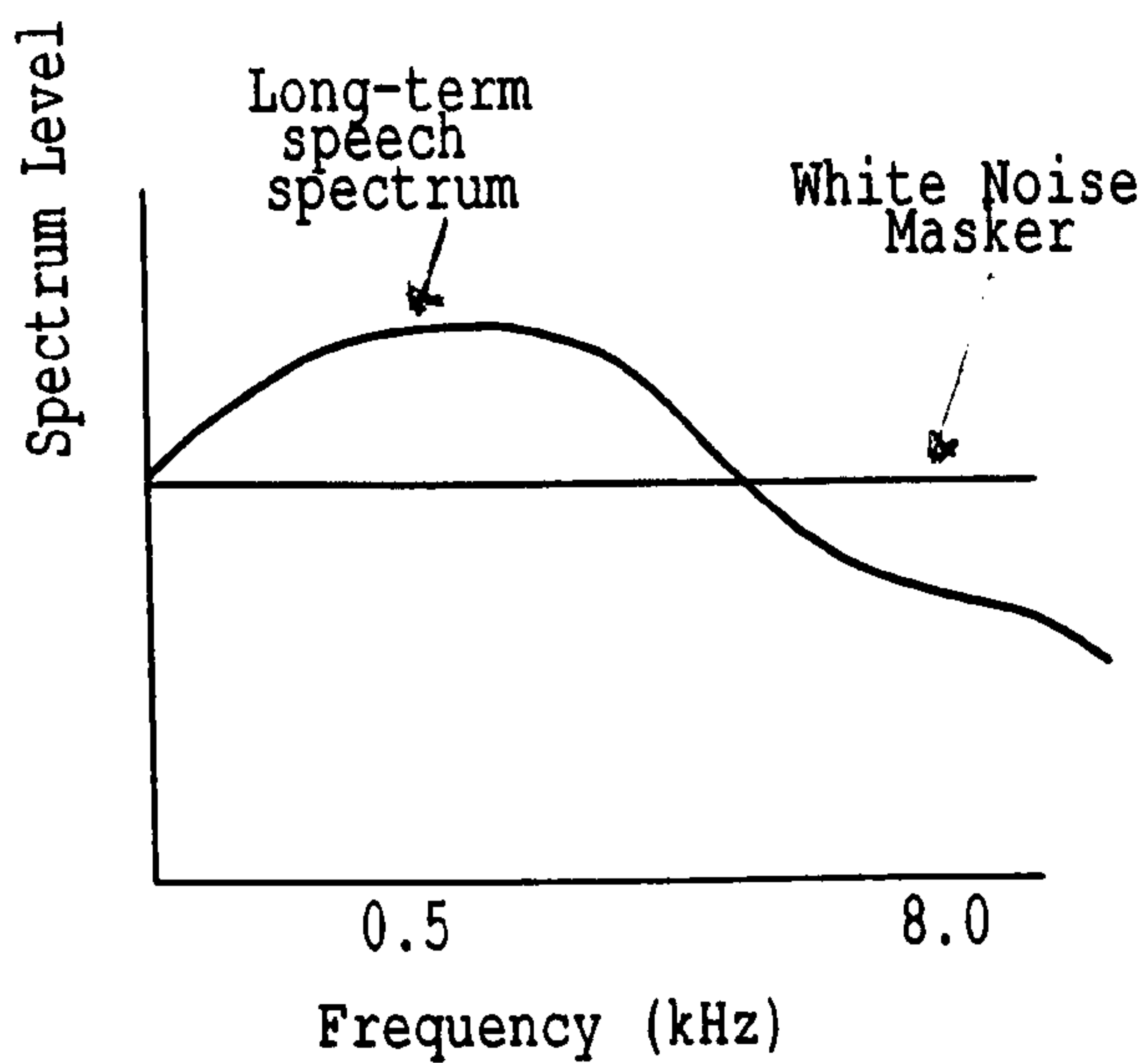

In other words OAD cannot be interpreted as being of a "purely psychological" nature.

(ii) Subjective Condition

The subjective condition of the PFFIN test measures a combination of actual performance ability and perceived ability. It is not surprising that OADs set significantly less adverse S/N ratios than controls during the SSRTN and SSRTB in view of their measured performance deficit. However, group differences in SSRTN/B were only partially accounted for by the PSRTN/B and other psychoacoustic and cognitive factors. This clearly shows that personality-related factors also influence the SSRTN/B. (This is discussed below.)

(iii) PS-discrepancy.

The PS-DIS was calculated from the PSRTs and SSRTs in order to distinguish between the effects of actual performance ability and personality-related influences upon the SSRTs. Essentially then, the PS-DIS is a measure of the degree to which the PSRTN/B and SSRTN/B differ. A large PS-DIS might originate from one of two sources, either from a mis-interpretation of the instructions for the SSRTN/B "to set a level at which you can just understand everything that is being said", or from a mis-judgement of actual hearing ability. Both would result in the SSRT differing from the PSRT. For both the PS-DISN and PS-DISB OADs had larger positive values. This implies that relative to controls they underestimate their hearing ability.

The nature of such underestimation can be explained in terms of signal detection theory (TSD), as proposed by Tanner & Swets (1954). TSD states that all signals have to be detected against a background of noise, originating from within, and possibly also from outside the (auditory) system. At stimulus presentation an individual must decide whether a signal was present in that stimulus. When the signal is weak, non-sensory factors, such as probability of the signal being present or the outcome of making a false positive/negative response, play a major role in whether or not an individual decides that a signal was/was not present. These factors lead the individual to develop an internal criterion for deciding whether or not a stimulus was present. Personality traits such as neuroticism (Stephens, 1969) have also been shown to influence the criterion. As applied to the PFFIN test, the listener's task was to decide whether or not he/she heard the speech signal correctly or not. Individuals with a strict internal criterion would interpret the instruction to "just understand everything" more strictly, and due to lack of self-confidence or to being more neurotic, would be more likely to underestimate their hearing ability, relative to an individual with a less strict criterion. This would lead them to set a less adverse S/N ratio for the SSRTs than they required during the PSRTs. It might be concluded that OADs have a stricter internal criterion than controls. Since no other measure was made of self-confidence nor of neuroticism *per se*, it is not possible to suggest the underlying cause of such a strict internal criterion. Further support for this TSD-based explanation for the PS-DIS comes from the finding of a positive correlation between age and PS-DIS ($r=0.33$, $p<0.001$) among the combined group of 50 controls and 15 patient-controls¹. It is well

¹Chapter 5 describes the patient-controls

established that decision criteria become more strict with increasing age (Botwinick, 1966). There could be no such correlation between age and PS-DIS among the OAD population because, as described above, factors acting upon the internal criterion are present in individuals, regardless of age ($r=0.19$, n.s.).

Despite the strong arguments in favour of the above, there was no detailed investigation into why the OAD population have come to use a relatively strict criterion. Clinically, counselling can be sufficiently general as to make this unnecessary. However, scientifically it would be of interest to confirm this hypothesis with some signal detection experiments and to elucidate its basis with a wider range of personality measures.

(b) FAAF Test

The significant group difference on the FAAF test shows that OADs have a small deficit for discrimination of filtered speech in quiet, even though their complaints are specific to speech-in-noise. Comparison of the p-values, however, shows that relative to controls, OADs performed more poorly at the speech-in-noise task than at the filtered speech task. Conventionally hearing-impaired individuals also tend to notice difficulties hearing speech-in-noise before other types of difficulties, possibly because it is the most frequently occurring of adverse circumstances for hearing. The finding that audiogram measures were not significant covariates of the group differences in FAAF scores, but that psychoacoustic variables were, shows that the FAAF test does reflect subtle auditory factors, for which it was initially

designed. The dichotic listening conditions were also significant covariates. Dichotic are unlikely to be reflecting linguistic processing ability, since the test is a forced-choice closed-set test. They must, therefore, reflect overall processing capacity.

(c) Audiovisual Test

Significant group differences were found in the VSRTN and ASRTN, but not in the derived variable of lipreading. This gives further weight to the finding that OADs have a measurable basis for their complaints of difficulty hearing speech-in-noise. On the other hand, it rules out lipreading as a basis for patients' reports of auditory disability. This is not to deny that poor lipreading ability may explain OAD in some individuals, but rather to assert that within the general population there are many individuals as poor at lipreading as some OADs. It would seem that a lipreading deficit alone will not lead to OAD, but that it can influence OAD status when it is present with some other trait (such as anxiety or a mild psychoacoustic deficit). Table 3.2 shows that 19 patients (38%) who attended the clinic were found to have a lipreading deficit, but that 18 of these (36%) had additional factors influencing their OAD).

3.5.1.4 Central/Cognitive Tests

(a) Dichotic Listening Test

There was a group difference in performance on the focussed attention condition of the dichotic test, but

not in the divided attention condition. However, level of performance among OADs did not differ significantly between the two conditions. It cannot, therefore, be conclusively claimed that OADs have a deficit specific to attentional abilities. Their deficit might equally lie in general linguistic/cognitive processing ability. The finding that group differences in dichotic ability are removed when the occurrence of reading/writing difficulties in childhood is taken into account tends to favour the latter explanation. So does the trend (although non-significant) for OADs to have less strong REAs than controls, in that an REA is thought to reflect brain lateralisation, which in turn is thought to influence linguistic processing (Kinsbourne, 1973). The finding that controlling for gap-detection ability removes the group differences in dichotic performance is not surprising in view of research showing gap detection ability to have a central, as well as a peripheral, basis (Lackner & Teuber, 1973; Zwicker & Schorn, 1982). This does not, however, help to determine the actual nature of the OADs' deficit for dichotic listening.

It has been shown that OADs as a group have a form of mild central dysfunction. This work did not aim to specify its nature any further. From an ENT clinician's point of view this is probably not of practical importance, since the deficit is sufficiently mild as to require no special treatment, just appropriate explanation and counselling. However, further work to learn more about the actual nature of this deficit would be of interest from a scientific point of view.

(b) Sentence Monitoring Test

The null findings on the sentence-monitoring test leave it unclear as to whether OADs have poorer linguistic ability than controls. The experimental findings here suggest not. However, the simpler test used in stage I did show a marginal group difference. It is possible that the test devised here was insensitive to small differences in ability. The general validity of the test is not in question, since reaction times differed in the expected direction with each condition (appendix 3.10, table 3). However, there may have been insufficient stimuli to obtain a reliable group difference in measurements; or else the factors influencing reaction-time, independently of linguistic processing, have confounded the results. The data of Sin (1987), who independently altered linguistic context and sentence rate, give evidence for this. On the other hand the nature of the linguistic deficit in OAD might not be based specifically in a poor use of context (as measured by this test) but in some other aspect, such as overall rate of processing. Further work is therefore required to confirm or otherwise that linguistic skill is not a factor in OAD.

(c) Cognition-Related Factors from the Interview

More OADs than controls reported difficulties learning to read and write when young, although the actual number of individuals reporting such difficulties was small (12 OADs versus 2 controls). Reports were not validated externally; therefore these data might be influenced by a reporting bias. Nevertheless, the finding suggests a mild central processing disorder might be influencing OAD in

some individuals. This interpretation is further supported by the finding that group differences in performance on the dichotic listening test were removed when learning difficulties were taken into account with ANCOVA. It would be useful to further investigate this finding in the future.

The finding that more OADs than controls reported respiratory and/or cardiovascular illness might lend further support to the suggestion of Cunningham et al (1987) that respiratory disease is associated with central auditory dysfunction. However, there was no correlation between report of cardiovascular disease and performance on the dichotic listening test, nor were reports of cardiovascular disease validated externally.

3.5.1.5 Personality-Related Factors

(a) Crown-Crisp Questionnaire and Health Beliefs

OADs had marginally higher scores on the phobic and obsessive anxiety scales than controls, and on the combined scale of general anxiety, phobic anxiety and somatic anxiety. This shows that to a degree OADs are more anxious than controls. These findings are consistent with those of stage I, in which OADs had higher scores on the phobic, somatic and combined anxiety scales. It is of interest that in both stages I and II of the study, it is the phobic anxiety scale on which the two groups most differed. General anxiety, and phobic anxiety in particular, probably causes OADs to feel vulnerable to health problems and hence to seek medical attention for milder symptoms than less anxious/phobic individuals,

(Gochman & Saucier, 1982). The link between phobic anxiety and OAD is discussed further in section 5.3.3.2.

3.5.1.6 Factors Associated with an Otological History

Tinnitus and familial hearing disorder were reported more frequently by OADs than by controls, although childhood and adult ear disorders were not. As in stage I the combined scale otological history (combining past and present ear disorder, familial disorder and tinnitus) was strongly correlated with anxiety among the combined OAD and control groups ($r=0.32$, $p<0.001$). Bearing this in mind, and given the fact that reported otological history was not confirmed by external sources, three possibilities arise to explain the group differences in otological history: (i) Patients may genuinely have experienced a greater past history of ear disorder, due to which the individual has become more anxious, (ii) anxiety might enhance a patients awareness of his/her hearing and hence influence recall of symptoms that might not actually differ between the groups, or (iii) phobic anxiety in an individual might influence the vehemence with which symptoms are described, and hence increase the likelihood of referral. The second of these explanations seems most likely.

3.5.1.7 Reported Auditory Disability and Handicap

OADs had significantly higher self-rated auditory disability and handicap than their matched controls; this confirms their OAD status. However, the finding that

these group differences remained highly significant when performance on the various psychoacoustic, cognitive and performance tests were taken into account as covariates, both individually and combined, shows that these self-ratings are out of proportion to any measurable impairment that exists. This confirms that an element of OAD is, indeed, psychological in nature. A variety of performance measures significantly diminished the group difference in self-rated disability, while only anxiety did for self-rated handicap. First, this confirms the validity of the questionnaire, in so far as disability seems to reflect actual performance ability, while handicap does not. Self-rated handicap would appear to be influenced by non-performance factors, of which only anxiety is measured here. Second, it emphasises the need to consider personality variables when interpreting self-rating scales, both when dealing with OAD patients and with other individuals. (Section 6.2.4.3.2 discusses this further.) Finally, the group difference in self-rated handicap is larger than that for self-rated disability; this is additional evidence that OAD is strongly influenced by performance factors.

3.5.1.8 Summary and Conclusions

In summary, univariate analysis has confirmed the findings of stage I, that OADs differ from their matched controls on variables from each domain investigated.

3.5.2 DISCUSSION OF MULTIVARIATE ANALYSES

As mentioned above, multivariate analyses were used to learn (a) which variables best differentiated OADs from controls, and (b) what factors influenced OADs' actual scores on some of these differentiating variables. Clinically these findings could be applied as follows: first a patient's performance on the variables known to differentiate OADs from controls could be used to determine whether an individual was sufficiently like an OAD to warrant OAD management. Then, once this had been confirmed, the factors known to influence performance of OAD patients could then be investigated, to learn the particular basis of OAD in that individual. The discussion below centres on the interpretation of findings of the multivariate analyses. Their further incorporation into a clinical package is discussed in section 4.4.

Initially, all multivariate analyses were carried out for the group as a whole. It was then decided to investigate the possibility that within the population there were sub-groups of individuals with different forms of OAD, i.e to learn whether or not OAD consisted of different syndromes. If such sub-groups did exist, distinguishing them would have clinical application; for example individuals in one sub-group could undergo different forms of investigation and management from those in another. This would enable a more specific set of tests to be used for each individual. The sub-divisions investigated were therefore chosen for their potential practicality in a clinical setting; i.e on variables that would be known at the start of OAD investigation (age,

sex, noise exposure and pure tone sensitivity). Results showed that only sub-division by age and by pure tone sensitivity gave an improvement over the group as a whole in the modelling

3.5.2.1 Accounting for OAD Status

The four-factor model describing OAD status, derived by logistic regression, explained 49.8% of the total group deviance. Bearing in mind the general variability of health-related behaviour this figure is high enough to accept the model as valid and useful. The adequacy and validity of this model was further confirmed by DFA. By DFA the same four-factor model correctly classified 80% of patients and 90% of controls. (Note that the statistical procedure used was different.) Comparison of the final analysis with results from each of the preliminary analyses confirms that OAD is multifactorial. Only when variables from each domain were considered jointly was the optimal model achieved. The PSRTN and the PS-DISN each explained almost 20% of the total group variance, the cognitive and psychoacoustic determinants explained only about one third of this each. This is partly because the role of the psychoacoustic variable was pre-empted by the entry of the PSRTN, while the role of the cognitive/central variable was in part pre-empted by the PS-DISN. (For evidence see table 3.15, showing that within the OAD group the model of the PSRTN was based on psychoacoustic factors, while the model of the PS-DISN was based on the cognitive/central variable of focussed attention.)

The 80% of patients correctly classified here appears slightly lower than the 87.5% (i.e 7/8) NA subjects correctly classified in Earl et al's (1987) study. This difference, however, is very slight, especially when their sample size is considered. However, the slightly better classification probably lies in the fact that, unlike OADs, none of Earl et al's subjects had sought medical attention for their hearing difficulties. Thus, in their population there is no added source of variance stemming from individuals with relatively good psychoacoustic function, but having personality traits that predispose them to seek medical attention. That is, the balance of factors among Earl et al's subjects is probably more weighted to purely psychoacoustic explanations. Although in this study personality factors have been taken into account there are inevitably some aspects of personality/behaviour not covered by the test battery.

Accounting for OAD status after sub-division of the OAD group by age and by pure tone sensitivity was considerably improved within two of the four sub-groups (poorer-hearing and older sub-groups), but slightly diminished within the better-hearing and younger sub-groups. The improved accountability of status within the worse-hearing sub-group probably arose because OADs and controls were not matched for pure tone sensitivity, so the group difference between OADs and controls, in terms of peripheral auditory function, was increased relative to that in the group as a whole. In the better-hearing group, however, accountability diminished relative to that for the group as a whole, because, assuming that abnormalities other than reported severity increase with hearing level, the OAD and control groups became more similar in terms of peripheral auditory function. A

parallel explanation cannot hold for the young versus older sub-groups since OADs and controls were matched for age.

The variables PSRTN and PS-DIS entered the regression equation for status within the group as a whole, and within all four sub-groups. The focussed attention variable also entered the regression equation for status within the group as a whole and within three of the four sub-groups. When accounting for status within the group as a whole, the deviance explained by the PSRTN and PS-DISN was of similar magnitude. This relationship also held for three of the four sub-groups (worse-hearing, younger and older). Within the group as a whole and within the worse-hearing group the focussed attention variable explained about one third less of the deviance than the PSRTN and PS-DISN. Within the better hearing group, however, the relative amounts of deviance explained by the PSRTN and focussed attention variables was reversed. In other words, in a group of OADs selected for good peripheral auditory function, cognitive variables become relatively more important in explaining OAD status. Within the younger group the PSRTN and focussed attention variables explained similar amounts of group deviance. It suggests that there was also some variation in peripheral function among the younger OADs, else factors in the model would have been more similar to that of the better-hearing sub-group.

It is of importance that OAD status can be accounted for by similar variables within each sub-group (even though their relative importance changes) since it implies that the actual determinants of status do not change substantially with pure tone sensitivity or with age. This simplifies any clinical procedure, in that these

factors need not be considered when confirming a diagnosis of OAD.

In summary, accounting for OAD status confirms that OAD is a multifactorial syndrome in which psychoacoustic, cognitive, and personality-related factors all play a role. These factors do not change substantially with age or with pure tone sensitivity.

3.5.2.2 Modelling of Abilities

Modelling of the PSRTN and the PS-DISN with multiple linear regression revealed that within the OAD group as a whole, performance on these variables is only modestly explainable from the other variables in the test battery. After sub-division by pure tone sensitivity and by age, considerably more of the total variance was explained by the models for the PSRTN and PS-DIS in six of the eight (overlapping) sub-divisions. This general trend of improvement could justify sub-division by these variables as being valid. However, there was no statistical procedure available to test whether this improvement was statistically significant. Nevertheless, globally it confirms the hypothesis that there are sub-groups within the OAD population, within which the factors influencing performance, but not OAD status, are similar, and between which they differ.

3.5.2.2.1 Modelling of the PSRTN

(a) Degree of Variance Explained by the Models

As compared with the group as a whole, more variance in PSRTN was explained by the model within the better-hearing group, but less was explained within the worse-hearing group. This is probably because standard deviation (S.D.) in PSRTN scores was greater in the better-hearing group than in the group as a whole, while the converse was true for the worse-hearing group (S.D. of PSRTN scores within whole group: 3.8; within the better-hearing sub-group: 4.2; within worse-hearing sub-group: 3.3).

For division by age the model explained substantially more of the total variance within the younger sub-group, and marginally more within the older sub-group, probably for similar reasons to those above (S.D. of PSRTN scores within the whole group: 3.8; within the younger sub-group: 4.1; within the older sub-group: 3.2).

(b) Variables in the Models of the PSRTN

Pure tone sensitivity, low-frequency masked threshold and the BMLD all entered one or more of the models of the PSRTN. Globally the entry of these psychoacoustic variables confirms that sensory abilities are necessary for discrimination of speech-in-noise. More specifically, the entry of the masked threshold reflects the need for good frequency resolution and/or a good internal S/N ratio. The entry of the BMLD probably reflects the binaural nature of the PFFIN test. The only other variable to enter a model was sex. This is almost

certainly acting as a carrier for another variable.

(i) Within the Whole Group

Within the group as a whole the PSRTN is determined by a combination of psychoacoustic factors and sex. The negative coefficient of sex implies that men perform better than women. In view of the entry of the masked threshold, it is likely that sex is carrying a variable of cognitive nature (also important for discrimination of speech-in-noise).

(ii) Within the Better- versus Worse-Hearing Sub-Groups

Within both the better-hearing and worse-hearing sub-groups, variables in the model of the PSRTN were of psychoacoustic nature. In the better-hearing group average audiogram enters the model after the masked threshold with a paradoxically positive regression coefficient. This is probably correcting for the fact that some of these individuals have worse masked thresholds than would be expected from their pure tone sensitivity. This points to a psychoacoustic explanation of OAD in better-hearing individuals.

In both sub-groups, then, performance on the PSRTN is determined by psychoacoustic ability, especially within the better-hearing sub-group. This demonstrates that minor deficits in psychoacoustic function can affect discrimination of speech-in-noise, even for individuals with pure tone sensitivity well within the normal range. The pattern of determinants was similar within both sub-groups (mainly psychoacoustic variables entered the regression equations). Clinically, therefore, these

particular results do not have practical application.

(iii) Within the Young versus Older Sub-Groups

The variables in the model of the PSRTN within the younger sub-group were of psychoacoustic nature. In the older sub-group sex is almost certainly acting as a correction for another variable. However, it is not possible to determine the actual nature of that variable.

Thus, in the younger sub-group psychoacoustic variables are influential in explaining the PSRTN, but in the older sub-group, sex is the only significant variable. However, there is the possibility that is correcting for a variable of psychoacoustic nature. Therefore one cannot conclude with certainty that variables of a different nature have entered the models. Once again, therefore these results do not have clinical application.

3.5.2.2.2 Modelling of the PS-discrepancy

(a) Degree of Variance Explained by the Models

Within the group as a whole, the model explained only 11% of the overall variance in PS-DISN. When the population was sub-divided by hearing sensitivity and by age, the models explained substantially more of the variance within all four sub-groups, but especially within the worse-hearing sub-group. This justifies the sub-dividing of the population for analysis.

(b) Variables in the Models of the PS-DISN

The focussed attention variable, sex and otological history all explain the PS-DISN in one or more of the groups.

The PS-DISN (i.e the extent to which an individual misjudges his/her hearing ability) probably reflects lack of self-confidence or lack of confidence in hearing ability *per se*. This probably leads to the individual developing a stricter internal criterion for positive acceptance of hearing a signal. The entry of otological history into the model is understandable in that a history of ear disorder might cause individuals to worry about their hearing at present; they could hence lose confidence in their ability to hear, although this is not the only possible interpretation. The entry of sex, with a positive regression coefficient shows that women underestimate their hearing to a greater extent than men. OAD women were more anxious than the OAD men (correlation of sex with anxiety: $r=0.44$, $p<0.001$). Hence, the entry of sex into the regression equation probably reflects the influence of anxiety level upon the PS-DISN. The explanation for the entry of the focussed attention variable is a little more difficult. This variable probably reflects general linguistic processing ability. The effect of poor linguistic processing ability might possibly be overcome during actual performance if the individual uses much effort. However, under the self-assessment conditions, when the individual might be less motivated to use effort, poor linguistic processing abilities begin to have an influence. A similar argument can be applied to the entry of gap detection into the regression equation within the better-hearing group.

(i) Better- versus Worse-Hearing Sub-Groups

The entry of psychoacoustic variables in the better-hearing group might suggest that the effects of mild peripheral deficits (e.g minor dysfunction of frequency and/or temporal resolution) can be overcome during performance, if that individual has good pure tone sensitivity, but that under the less motivating self-assessment conditions these minor deficits have an influence. This seems unlikely, however, in view of the entry of psychoacoustic variables into the model of the PSRTN within the better-hearing group. In the worse-hearing group any minor psychoacoustic deficits would be compounded by poorer pure tone sensitivity, and hence central/linguistic deficits might begin to influence subjective assessment but can be overcome during actual performance by putting extra effort into listening; nevertheless, their effects would still be felt subjectively.

(ii) Young versus Older Sub-Groups

A similar explanation to that above for the worse-hearing group can probably be applied to the entry of the focussed attention variable into the regression equation for the older group. Otological history in the younger sub-group might reflect long-term worries about their hearing, originating from clinical interest in otitis media in childhood that became widespread in the 1960s and 1970s, when these individuals would have been children.

To summarise, different patterns of variables entered the regression equations within each sub-group for modelling

of the PS-DISN. However, their particular patterns are not easily rationalised and therefore are not applicable to clinical practice.

3.5.2.3 Summary and Conclusions

Multivariate analysis once again confirmed the multifactorial nature of OAD and the importance of considering the influences of variables from psychoacoustic, cognitive and personality-related domains on OAD. The four variables best differentiating OADs from controls are not conditioned by age or pure tone sensitivity. This is a clinically useful finding, suggesting that a common test battery is appropriate for all sub-groups when investigating OAD status in an individual.

Modelling of the PSRTN and PS-DISN for the sub-groups shows that within the OAD population there do exist groups which can be differentiated by age and pure tone sensitivity. Scientifically, therefore, these analyses are useful and informative. However, from a clinical point of view the variables influencing the PSRTN and PS-DISN do not differ between the sub-groups sufficiently to justify structuring, or even modifying, the clinical package on these differences.

3.6 GENERAL SUMMARY AND CONCLUSIONS

The first aim of the study, to understand the basis of OAD has been completed. The study has shown that OAD is a syndrome in its own right, for which a reliable statistical model has been defined. The findings of stage I have largely been confirmed, and elaborated upon. As a group, patients have a measurable performance deficit, hence their reported disability has a sensory basis. However, this reported disability/handicap cannot be entirely explained by peripheral or central impairment, but is also influenced by personality factors. The statistical model shows that patients' performance deficit is due to a combination of a psychoacoustic impairment (poor frequency resolution and/or a poor internal S/N ratio) and a central/cognitive processing deficit (poor ability to focus attention). The single most important personality-related factor influencing patients' reported disability/handicap is a mis-judgement (underestimation) of hearing ability. Aside from these four main factors, poorer temporal resolution and lipreading ability and a more common history of otological disorder (among others) also differentiate patients from controls.

Figure 3.7 depicts the model of OAD, as determined by the multivariate analyses. Its similarity with the model devised after stage I (figure 2.5) should be noted.

The finding that OAD can be reliably modelled has enabled the second aim of the study (to devise a package of tests and interviews for diagnosis of OAD in the clinic) to be completed. This is described in chapter 4.

Figure 3.7 Factors shown by Multivariate Modelling to Influence OAD Status and Performance

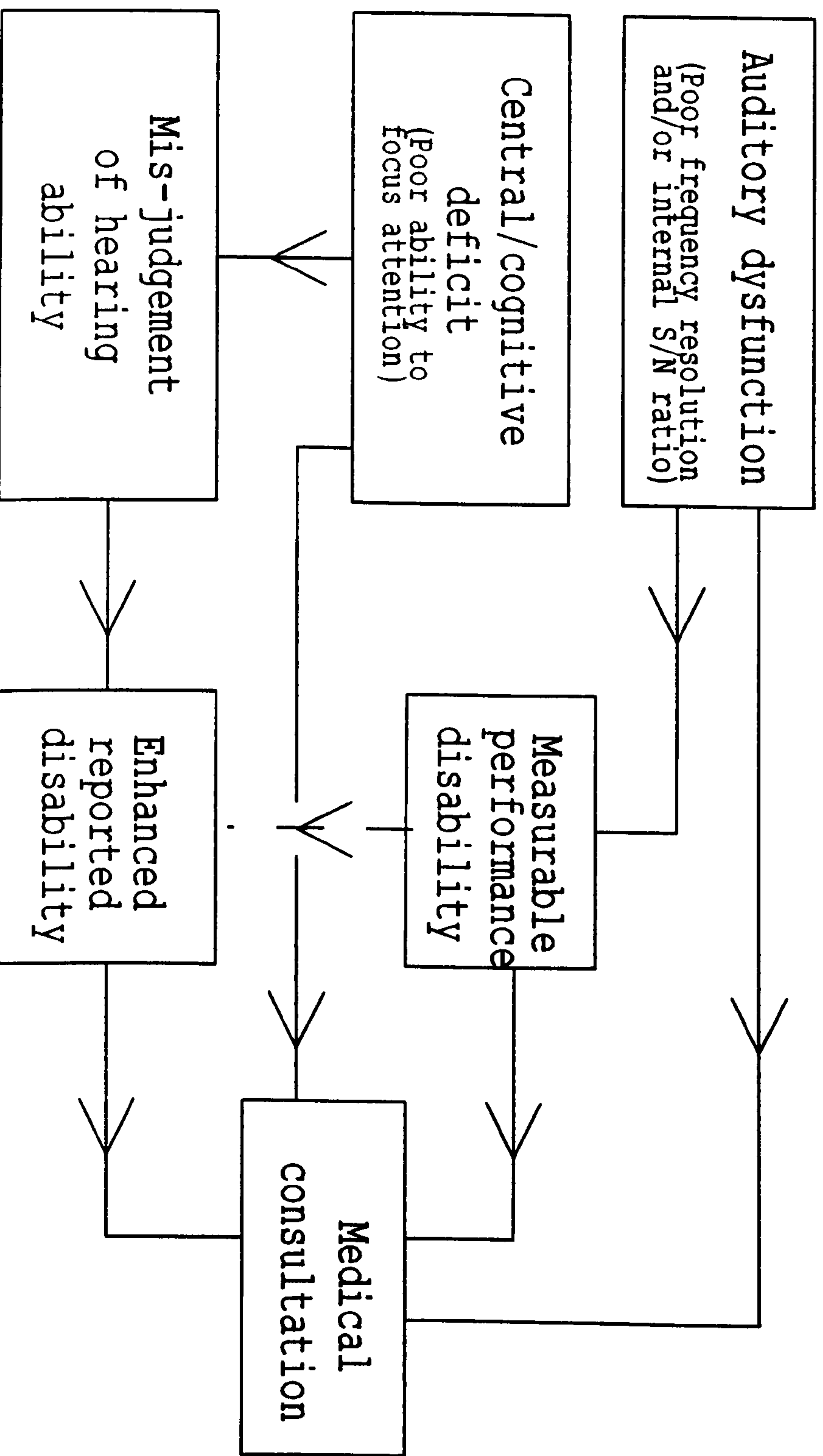

CHAPTER 4

4.1 INTRODUCTION

Clinical Consequences of the OAD Project

As described in section 3.3.1, OAD patients were referred to a Special Investigative Clinic set up at the MRC Institute of Hearing Research in Nottingham. In addition to its research aims, the clinic was run as a service to ENT consultants in the Trent Health Region for the assessment of OAD patients, because consultants were unable to investigate them satisfactorily in their own clinics. This was either because they lacked testing facilities/materials, or an appropriate clinical protocol, or because insufficient numbers of OAD patients attended their clinic to make the adoption of a protocol practical.

After assessment at the clinic, each patient received an explanation of their results and was given counselling in the form of reassurance and advice on hearing tactics. Following this, the referring consultant received a report that was about two pages long, detailing the following: the patient's reported difficulties, the test findings, advice given by us to the patient, and, where relevant, advice on appropriate follow-up. (Appendix 3.2 contains a typical patient report.) These reports were written by the experimenter, with supplementary advice from senior staff where necessary, in particular, from the Institute's consultant audiological physician in cases where the possibility of neuro-otological or other conventional auditory pathology was indicated.

As described in chapter 1, one aim of the project was to devise a simple test package for assessment of OAD patients that could be used by the consultant in his/her own clinic. It was felt important, therefore, to assess the opinions of both consultants and patients on the clinical service provided; to this end two questionnaires were compiled and sent to consultants and patients respectively.

4.2 EVALUATIONS

4.2.1 Consultants' Evaluation

4.2.1.1 Subjects

15 consultants, who had referred one or more patients to the Special Investigative Clinic, were sent the appropriate questionnaire to assess their satisfaction or otherwise with the clinical service.

4.2.1.2 Procedure

Simple direct questions were designed by the experimenter to elicit in a consultants' opinions on three main topics in a quantifiable way. These topics were:

- (a) General communication with the Institute of Hearing Research

(b) Reports on patients

(c) General factors - any feedback from patients, personal comments and preferences for the future of the clinic

(Appendix 4.1 contains the complete questionnaire.)

To retain the anonymity of individual consultants, Mr J.T. Buffin (FRCS), Chairman of the Trent Regional Health Authority's Audiology Working Party (a sub-committee of its ENT Advisory Committee), received the replies. He then sent coded copies of the questionnaires to the Institute of Hearing Research for evaluation by the experimenter, retaining the key as to the identity of each. From the 15 questionnaires sent, 14 replies were received.

4.2.1.3 Results

This section contains a summary of a report presented to the Trent Regional Health Authority Working Party, 20th June 1988.

(a) General Communication with the Institute of Hearing Research

10 consultants felt the material introducing the clinic and interim reports about progress was very clearly presented; 4 felt it adequate.

Only 2 consultants wanted to receive regular reports on research findings, the remaining 12 wished only to receive patient reports.

(b) Consultants' Comments on Patient Reports

12 consultants felt the patient reports provided about the right quantity of information, the remaining 2 felt the reports were too detailed.

11 found the implications of the clinic findings were made 'as clear as the condition permits'; 2 felt they were made fairly clear, while 1 felt they were not made clear enough.

10 consultants did not feel the reports lacked any particular information. Among the remaining 4 consultants, 3 felt that the reports lacked a firm diagnosis and conclusion, and 1 requested more information on the assessment methods, their development and limitations.

(c) General Comments

Among the 6 consultants that had received patients' comments about the *clinic procedures*, 2 reported that comments had all been favourable, 1 found comments had mostly been favourable. The remaining 8 consultants had not received any patients' comments.

6 consultants received comments from patients about the *overall value* to that patient of attending the clinic, among these 2 reported comments had been wholly

favourable, 3 had been mostly favourable, and 1 had received neutral or contradictory feedback. The remaining 8 consultants had not received any patient feedback.

When invited to make suggestions for improving the service, 2 wanted firmer diagnoses and conclusions, 1 requested more information about numbers that could attend the clinic, and 1 thought the clinic would be of interest in head and neck oncology. The remaining 10 consultants did not offer any comments.

When asked for preferences of how the service for OAD patients should continue, 7 preferred the continuation of a regional clinic along the existing lines, 5 preferred the provision of a package of tests for use within local hospitals, and 2 did not have a strong preference.

4.2.1.4 Discussion and Conclusions

The overall reaction of consultants to the clinic was generally very favourable, in terms of provision of information about the clinic, reports on patients, and patient feedback to consultants by patients. Some consultants felt that the reports could have had clearer diagnostic conclusions and implications. This only real criticism might, perhaps, have been anticipated in view of the following. First, re-reading the early reports show this criticism is justified. This was inevitable, however, because although the syndrome had been previously recognised, it had never been investigated in a multifactorial manner, so at the start of testing there was no information about the relative importance of each type of factor. Second, there are no studies

detailing any form of follow-up on patients with OAD symptoms, so the course of any progression of the condition is unknown; hence a firm prognosis was inevitably lacking. Finally, although the tests were piloted with normally-hearing individuals, they were specially designed for the clinic and, therefore, had never been used before for clinical evaluation. Diagnostic conclusions, therefore, were necessarily based on relatively little data to begin, and, hence, were made with caution. As the number of patients visiting the clinic increased, it became possible to make firmer conclusions, based on more empirical data. In order that in the future diagnostic and prognostic implications can be given with more certainty, patients from stages I and II are to be followed-up and a new form of the clinic has recently begun using the Clinical Test Package (section 4.4).

The majority of consultants reported they would prefer to refer patients to a regional clinic for OAD investigation, rather than to test patients themselves (7 versus 5). This is probably because ENT departments do not have sufficient time to take on extra testing. While referral to the Institute is a practical possibility for patients from local hospitals, it is not so convenient for those living further away. The Institute is continuing a clinical to cater for local patients, and for some living further away who are willing to travel some distance. A clinical test package has been designed for use in regional centres so that less mobile patients living further away can also benefit from the study. Tests in the package can be run using standard audiological equipment in a short period of time - about 40 min (see below for details).

4.2.2 Patients' Evaluation

4.2.2.1 Subjects and Procedure

All stage II patients attending the clinic were sent a questionnaire to assess their satisfaction, or otherwise, with the clinic. It included questions under two main headings:

- (i) The test battery
- (ii) Results and advice

Appendix 4.2 contains the questionnaire

Anonymity was not retained for evaluation by the patients. This should be considered when interpreting the replies.

4.2.2.2 Results

37 out of 50 questionnaires were returned, a response rate of 74%. No reminders were sent to patients.

(a) Test Battery

36 respondents found the tests interesting; 1 did not.

31 found the testing time to be as expected, while 6 found the testing time too long. All but one person felt that the test instructions were easy to follow, and that the explanations of the purpose of each test were about right. One person found the instructions and explanations too complex.

(b) Results and Advice

32 respondents found the explanations of the results to be about right; 4 felt the explanations were too simple, and one person found them too complex.

27 respondents felt the advice given at the end of the testing was useful; among the remaining 10, 9 found the advice of no use because they already knew it, one person found it of no use even though he did not know it before.

36 respondents found the Hearing Tactics Leaflet clear and easy to follow, the remaining individual had not looked at the leaflet.

Regarding how worthwhile individuals found their visit to the clinic, 21 found it a very worthwhile visit, 12 found it fairly worthwhile, and the remaining 4 were equivocal over its worth.

Additional comments were offered by 19 patients. All but two were very complimentary. Patients' comments broadly fell in two categories: (1) the benefit they felt from receiving individual attention and acknowledgement of their problem from someone with specialised interest and knowledge of it; and (2) the confidence they had gained since their visit, plus the positive acceptance of their problem now they understood it better. 7 patients offered comments of the former type, 5 of the latter, and 5 of both types. Of the two non-complimentary comments, one was negative about the test battery (she found the tests too confusing and complicated), and one was negative about the management (he would have liked more information about present day hearing-aid technology).

4.2.2.3 Discussion and Conclusions

Interpretation of the highly favourable responses received should be slightly moderated in view of the lack of anonymity of the questionnaire replies and of there being no follow-up of non-respondents. Nevertheless, as with the consultants' evaluation, patients generally gave very favourable feedback on the clinic facilities, with 33 finding their visit was made worthwhile by the advice and reassurance they received. It was not unexpected that some patients found the testing time too long. However, at the research stage a long and diverse test battery was required so that many hypotheses could be investigated, in order that a shorter set of the most relevant tests could justifiably be put together for the clinical package (see section 4.4).

The majority of patients found the advice and counselling useful. Of the 10 individuals that did not, 7 still found the overall visit very or fairly worthwhile. That is, these individuals gained some form of satisfaction from their visit NOT based upon practical advice. A major benefit from most medical consultation is reassurance or the dispelling of anxiety (Berkhout, 1984). This is probably what these individuals gained from their visit. Both this, and the additional comments made by patients, support the view that there is much to be gained by spending some time investigating and reassuring a patient, even if the practical advice that can be given is somewhat restricted. At present, a study to evaluate counselling procedures is under way to optimise this practical advice. An element of patient satisfaction is probably based in a 'relief reaction' at finding someone with a specialised knowledge of, and interest in their condition. When evaluating the usefulness of advice given

in the present study care must be taken not to over-interpret psychological benefit from such a personalised service as being actual practical benefit. While the former is very valuable, a distinction must be preserved and practical benefit should also be aimed for.

4.3 OAD COURSE FOR CONSULTANTS

Once the research had been completed a course was run at the Institute of Hearing Research on the clinical implications and applications of the study. Its purpose was three-fold: first, it aimed to bring the OAD syndrome to the attention of clinicians as a syndrome that should be recognised in its own right. Second, it served as an opportunity to explain the content and uses of the clinical package and the counselling procedures, that arose out of the research. Finally it gave an opportunity to learn the views of those who would ultimately use the clinical package on practical issues such as the availability of time and equipment.

Course details were sent to all ENT consultants in the Trent region, any other consultants who had referred patients, to members of the British Association of Audiological Scientists and to members of the British Association of Audiological Physicians. 20 people attended the course on 14th September 1988, leaving a number of others who could not attend on that date, but would if the course were run again.

The course lasted one full day (Appendix 4.3 contains the course programme).

A major part of the course was spent describing and demonstrating the clinical test package, the development of which is described below.

4.4 CLINICAL TEST PACKAGE

4.4.1 Introduction

The clinical package was designed to allow investigation of OAD by clinicians in their own clinics. The final test package consisted of:

- (i) a cassette tape of four recommended tests (their selection was derived from the results of stage II)
- (ii) protocols and answer sheets for each recommended test
- (iii) a shortened version of the Special OAD interview and recommended interpretation of responses
- (iv) a shortened version of the IHR Hearing Questionnaire
- (v) a set of contingency pathways outlining appropriate management for each individual.

These contingency pathways were originally designed to determine the actual tests a patient would undergo; results from one test determine the next test in the sequence so that not every patient need have carried out every test. This type of testing makes the most efficient use of limited clinic testing time. However, discussions with various clinicians revealed that technicians are often reluctant to carry out tests contingently; they prefer to run tests in a battery. Clinicians report more consistent results from battery administration, and a smoother procedure through not having to correct misapplications of the contingency rules. Therefore it is now envisaged that, in the majority of clinics, these

pathways will be used only by the clinician to determine management regimes. In clinics where contingent testing is possible, the option remains for these pathways to be used as originally planned.

- (vi) recommendations about counselling and follow-up
- (vii) a circuit diagram for an adapter box (in order to enable the running of the recommended tests from a standard clinical audiometer and cassette player)

The rationale with which the package was developed is described below.

4.4.2 Theoretical Considerations in for devising the Clinical Package

In order for any tests to be clinically useful and practical two factors need to be considered:

(a) The time a clinician can spend with a patient is limited, as is the time available for testing. The tests in the package were, therefore, designed to be used contingently, so that not every patient needs to do every test, thus making the most efficient use of limited time.¹

(b) The relevant test equipment available in an average clinic is limited to a cassette recorder and audiometer. Any test from the OAD stage II battery that could not be adapted to run on this equipment was not considered for

¹See (v) above for a qualification of this.

inclusion in the package (these were: the gap detection test, the sentence-monitoring test and the audiovisual test). Fortunately analysis showed that none of these tests played sufficient explanatory role to warrant inclusion anyway (table 3.13) so no efficiency was lost by this limitation.

The selected tests were recorded onto cassette from copies of the test materials used in stage II of the project. A biological calibration, using the equipment and procedures recommended in the package, was carried out with 50 normally-hearing listeners, to obtain norms for performance for running the tests from the audiometer, as opposed to the more sophisticated laboratory equipment used in stage II.

4.4.3 Tests in the Package

The variables finally recommended for the package were those that entered the four-factor model for prediction of OAD status (table 3.13). They are:

- (i) The performance SRTN - a performance test of disability for speech-in-noise (PFFIN test).
- (ii) The PS-discrepancy - a test of the degree to which an individual misjudges their hearing ability (also from the PFFIN test).

The whole PFFIN test takes 10 min to carry out, and results in the performance SRTN (PSRTN) and the PS-discrepancy (PS-DIS).

- (iii) The focussed attention condition of the dichotic listening test - a measure of central auditory ability. (10 min test time)

- (iv) Mid-frequency masked threshold (low-pass condition)
- a combined measure of frequency resolution and effective internal S/N ratio. (5 min test time)

In addition the handicap questions from the IHR Hearing Questionnaire (approximately 2 min test time) and a shortened version of the OAD interview (10 min test time) were included in the package.

Sections 3.3.4.1(a), 3.3.4.3(b), 3.3.4.2(b) and 2.3.3.1(a) & (b) give further details about these tests.

4.4.4 Use of the Clinical Package

During a typical testing routine, all patients will undergo all tests. A set of contingent pathways is provided for interpretation of the results to determine the appropriate management regimes for individual patients. However, in clinics that can cope with contingent testing, these pathways can be used to determine the actual tests a patient undergoes. Initially two such sets of pathways were devised, both of which were potentially acceptable. Ultimately one was discarded. The rationale with which they were devised and their relative merits weighed up is described below.

Both sets of contingency pathways used the following four general 'rules', but in different orders:

- (a) The handicap questionnaire determines the severity of OAD in an individual. This rating determines the amount, rather than type of counselling or further investigations

an individual undergoes, since it was felt that someone reporting severe OAD required more counselling and explanations than someone reporting less severe OAD.

(b) The size of the PS-discrepancy determines the type of counselling that an individual receives.

(c) All patients displaying a measurable performance deficit (low PSRTN), not explained by tests in the recommended battery, undergo referral to identify an explanation for their performance deficit.

(d) The criterion for normal performance on each test is defined as a score above the 90th percentile of control values. Any score below this figure is defined as 'abnormal'. For scores on the PS-DIS, where a high score is 'abnormal', this rule is inverted.

In the next sections the two sets of contingency pathways are described. The first decision in pathway Set A is based upon the reported severity of OAD by individuals; in Set B the first decision is based upon the performance ability.

After each pathway is described the percentage of the total number of patients from stage II of the study (n=50) fitting that description is given in brackets. Figure 4.1 shows Set A and figure 4.2 shows Set B.

Figure 4.1 Contingency Pathways - Set A

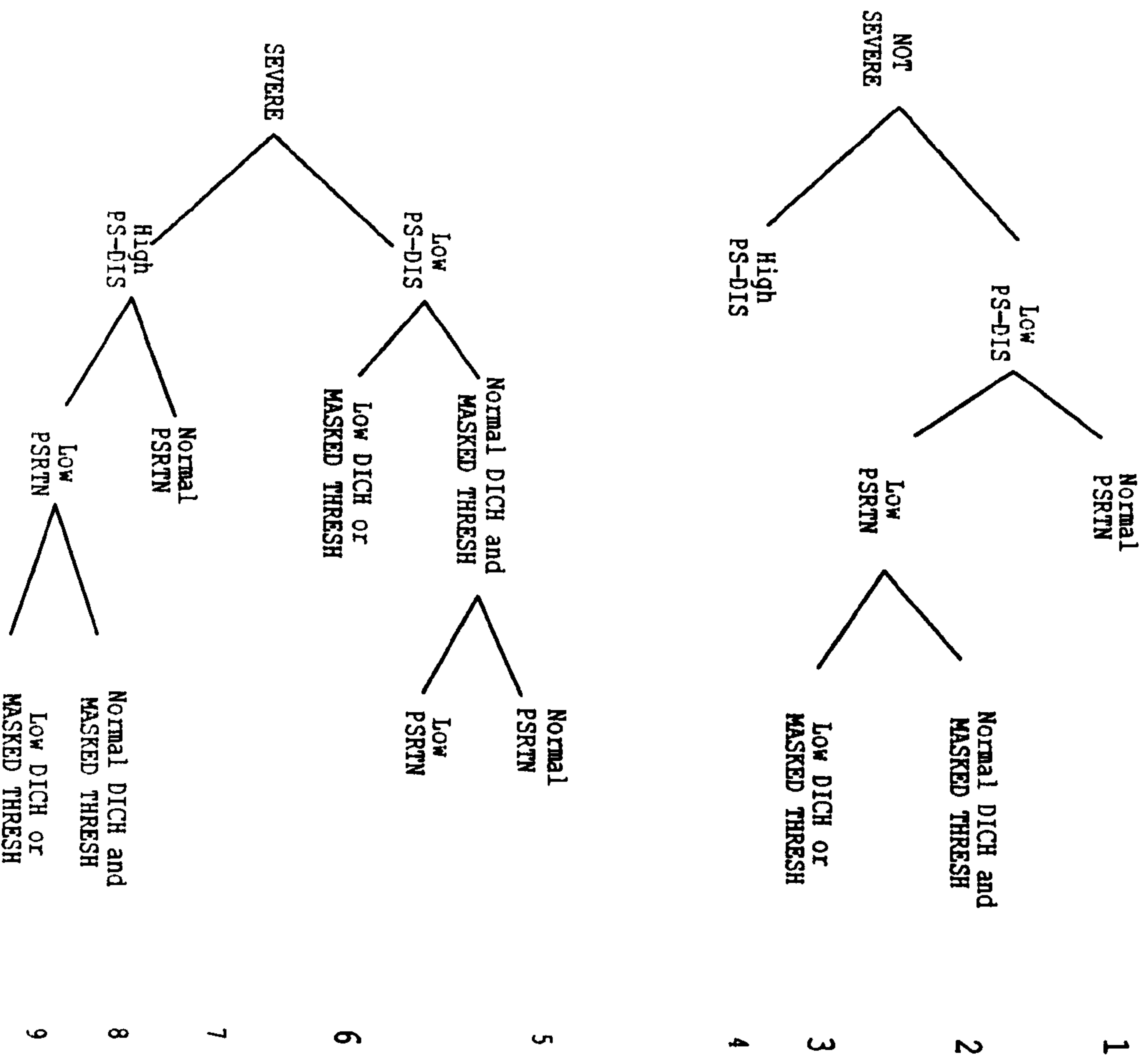
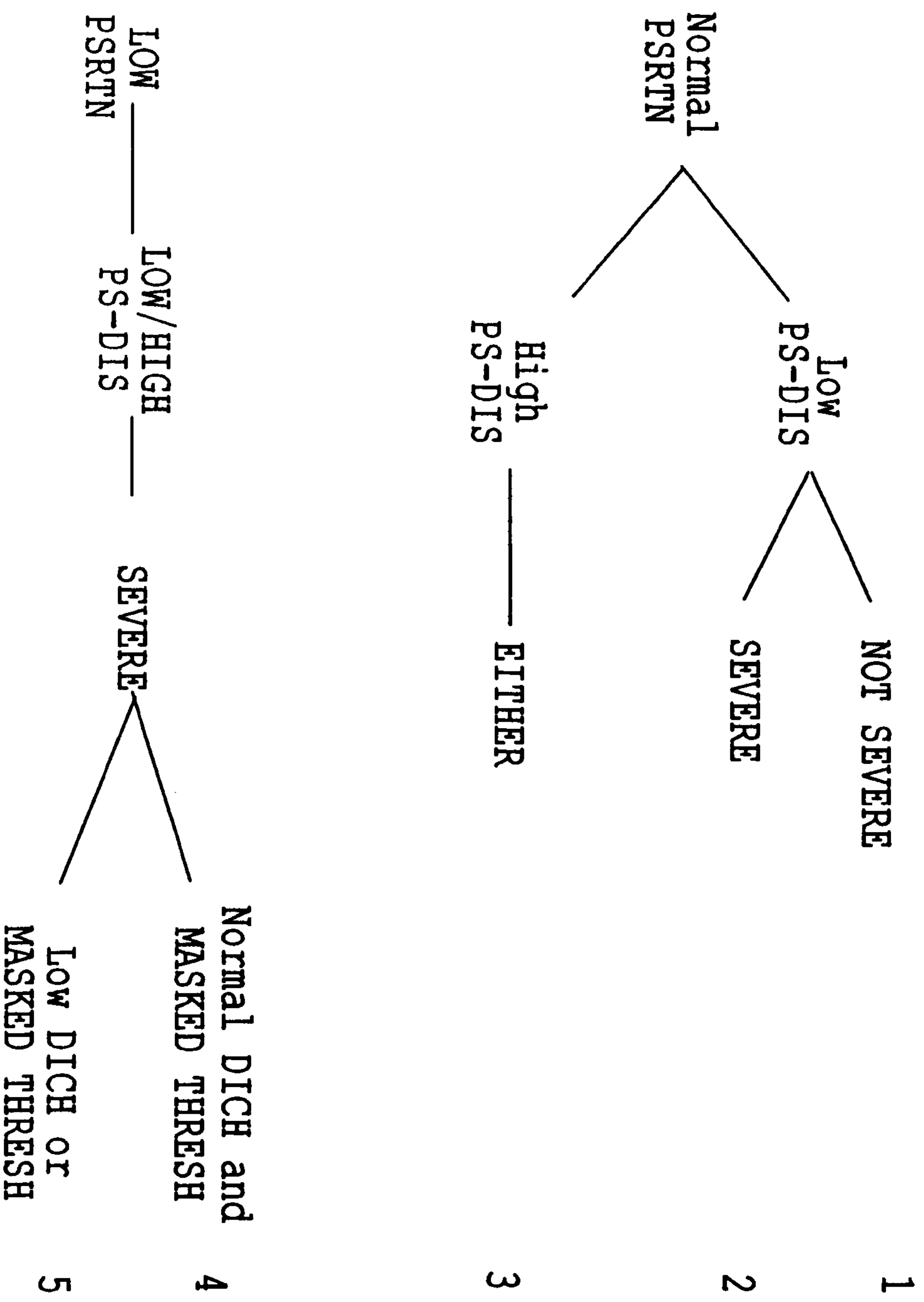

Figure 4.2 Contingency Pathways - Set B



4.4.4.1 Contingency Pathways - Set A

The first step in this set of pathways is determined by the reported 'severity' of OAD in the patient. More test results are considered when counselling patients experiencing severe OAD than when counselling those with relatively mild OAD.

Pathway 1 is for individuals with a low PS-DIS and normal PSRTN in whom there is no measurable disability. These individuals receive reassurance on the basis of their being no performance disability and relatively mild complaints [12%].

Pathway 2 is for those non-severe individuals with a low PS-discrepancy, normal PSRTN and normal performance on both the dichotic test and masked thresholds. These individuals are referred for further investigation, such as audiovestibular or electrophysiological investigation, since they have measurable disability whose cause has not been identified by the recommended tests [4%].

Pathway 3 is for those individuals with non-severe OAD, a low PS-DIS, a low PSRTN who performed poorly on one or both of the dichotic test and masked thresholds. These individuals receive counselling about how to cope with their disability. It would in part be based upon the particular form of the disability as shown by their masked thresholds and/or performance on the dichotic listening test [8%].

Pathway 4 is for non-severe individuals with a large PS-discrepancy. They receive counselling about their misjudgement of their hearing ability, as a large PS-DIS is thought to be a sufficient explanation for their

perceived handicap [14%].

Pathway 5 is for severe patients with a low PS-DIS, normal dichotic scores and masked thresholds with a normal PSRTN. These individuals receive reassurance on the basis of their not having measurable disability [6%]. This pathway differs from pathway 1, in that performance on the masked thresholds and dichotic listening test are considered in addition to that of the PSRTN because these individuals have more severe complaints.

Pathway 6 is for severe patients with a low PS-DIS, normal dichotic scores and masked thresholds with a low PSRTN. Like those in pathway 2, these individuals are referred for further assessment since the basis of their measurable disability has not been identified with the recommended tests [14%].

Pathway 7 is for severe patients with a low PS-DIS and poor performance on one or both of the dichotic and masked threshold tests. These individuals receive counselling about how to cope with their disability, partly based upon its identified cause. The PSRTN of these patients is not considered, since their poor dichotic and masked threshold results can be assumed to be the basis of their OAD. [18%].

Pathway 8 is for severe patients with a high PS-DIS but a normal PSRTN. They receive counselling regarding their mis-judgement of their hearing. (Unlike non-severe patients in pathway 4, the PSRTN of these patients is considered because it is thought less likely that severe OAD could be solely explained by a large PS-DIS. However, if the PSRTN does prove to be normal, their PS-DIS is assumed to be the sufficient explanation.) [16%].

Pathway 9 is for severe patients with a high PS-DIS, low PSRTN but normal performance on both the dichotic and masked threshold tests. These patients are referred for further assessment with the aim of understanding the basis of their measured disability but are also counselled regarding their mis-judgement of their hearing [2%].

Pathway 10 is for those patients with a high PS-DIS and a low PSRTN who perform poorly on one or both of the dichotic and masked threshold tests. These individuals receive counselling on their mis-judgement of their hearing and on coping with their disability that would in part be based on its identified basis [6%].

4.4.4.2 Contingency Pathways - Set B

The first step in this set of pathways is determined by the PSRTN. Individuals with a low PSRTN, not explained by results of tests in the recommended battery, are referred for further investigation to find an explanation for their measured disability; those without a measurable disability undergo counselling based upon fewer results.

Pathway 1 is for those individuals with a normal PSRTN, a low PS-DIS and non-severe OAD. These individuals receive reassurance on the basis of there being no measurable disability and relatively mild complaints [12%].

Pathway 2 is for those patients with a normal PSRTN, a low PS-DIS and severe OAD. These individuals are referred for further assessment in order to understand the basis

of their severe subjective handicap [16%].

Pathway 3 is for individuals with a normal PSRTN and a high PS-DIS. These patients receive counselling based upon their misjudgement of their hearing [26%].

Pathways 4 and 5 are for individuals with a measurable disability (low PSRTN). The size of the PS-DIS in these individuals influences their counselling. Severity ratings are not relevant to the counselling, because it is the low PSRTN that requires explanation, not their subjective opinion about it.

Pathway 4 is for individuals with a low PSRTN and normal performance on the dichotic and masked threshold tests. These patients are referred for further investigation to explain the basis of their measurable disability [18%].

Pathway 5 is for individuals with a low PSRTN and poor performance on one or both of the dichotic or masked threshold tests. These patients receive counselling on coping with their disability, in part based upon its identified cause [28%].

(The counselling regarding results from the dichotic test and the masked threshold test is at present based on a general theoretical understanding of what these tests measure. The project did not aim to cross-validate these measures. In the future it would be useful to investigate the practical implications of poor performance on these two tests in real-life settings.)

4.4.4.3 Theoretical Comparison of Sets A and B

Set A of these contingent decision pathways was preferred and recommended after taking the following considerations into account:

(1) Simplicity of Use

The fewer the possible pathways, the easier the interpretation of the results, and hence the more satisfactory a protocol is for use in a busy clinic. Both sets of pathways involve the same four tests, however they differ in the number of decisions a clinician must make when counselling a patient. Set A has a total of 10 possible pathways, with a maximum of 4 sets of results to consider. Set B has a total of 5 possible pathways, with a maximum of 3 sets of results to consider. On the basis of this alone, set B would be the more appropriate set.

(2) Testing Time

Discussions with various clinicians lead to the suggestion that tests should be run in battery form, rather than in the contingent manner initially intended. Therefore, each set of pathways takes the same time to run - a total of 37 minutes (including the OAD interview).

In clinics where testing can be carried out contingently pathway set A would take an average of 30.7 minutes, pathway set B would take an average of 27.5 minutes. On the basis of this set B would be the more appropriate set, but only marginally. The average testing time for an individual in each set of pathways was calculated by

multiplying the percent of patients (from stage II) that would have passed down each pathway by the time taken to carry out all tests in that pathway. Table 4.1 below shows the data for this calculation for sets A and B. The 10 minute period taken to do the OAD interview is included in these calculations.

Table 4.1

A breakdown of the testing time required for each pathway in set A and set B, if testing were carried out contingently

Pathways Set A			Pathways Set B		
Pathway no.	Testing time (min)	Percent patients	Pathway no.	Testing time (min)	Percent patients
1	22	12	1	22	12
2	37	4	2	22	16
3	37	8	3	20	26
4	22	14	4	35	18
5	37	6	5	35	28
6	37	14			
7	37	18			
8	22	16			
9	37	2			
10	37	6			

Average test time = 30.7min

Average test time = 27.5min

(3) Regimes of Management

After investigation, patients require some form of management. There are three forms of management recommended in each set of pathways: (i) simple reassurance to the patient that they have no measurable disability or other identified impairment, (ii)

counselling the patient for a measurable disability whose underlying basis has been identified, or (iii) referral of the patient for additional investigation to identify the basis of a measured disability of unidentified cause. From a clinical point of view it is desirable that the majority of patients receive management regime (ii); in other words the cause of their OAD status should be identified and explained. Fewer patients should receive regimes (i) and (iii). From the range of performance abilities of patients in stage II, it can justifiably be said that testing were to result in the majority of patients simply receiving reassurance it is likely that the test protocol is insensitive or the criterion for normal performance is too lax; on the other hand, if the majority of patients require referral, it is likely that the test protocol is too stringent or the criterion for normal performance is too strict, leading to an excess of referrals and inefficient use of clinical resources. This consideration is more important than those of time and simplicity. Comparison of the numbers of patients from stage II that would have received each of these treatment regimes within each set of pathways is as follows:

Pathways set A		Pathways set B	
Treatment	Percent patients	Treatment	Percent patients
Reassurance	18	Reassurance	12
Counselling	62	Counselling	54
Referral	20	Referral	34

The distribution of patients over the management regimes can be altered to an extent by shifting the various cut-off criteria; the differences between the sets of pathways are therefore not necessarily permanent. Nevertheless, on the presently imposed criteria, pathway Set A is the more satisfactory since it is able to explain OAD sufficiently for counselling in the majority of patients, (62% as compared to 54% in Set B). Only 38%, as compared to 46% in Set B are simply reassured or require referral. For this reason set A of the contingent pathways was recommended in the final clinical package.

4.4.5 Contingent versus Battery Testing

As mentioned above, the contingent pathways were initially designed to minimise clinical testing time, although discussions with clinicians revealed that in most clinics contingent testing would be impractical. Using the tests in battery form will add on an average of 7 minutes to the procedure. However, this small disadvantage might be outweighed by the benefit of fewer mistakes during application of the contingency rules.

4.4.6 Future Research

It is likely that this initial set of pathways will require amendment because the present process for deciding the treatment regimes (referral versus counselling versus reassurance) was necessarily retrospective. The decisions were based on experience of testing and counselling patients that attended the

Special Investigative clinic during stage II. The recommendations and such decisions require validation by further research in (a) understanding what, in practice, poor performance on the dichotic test and on the masked thresholds implies, and (b) the assessment of the success of the recommended counselling to reveal whether there is a subset of patients that benefit from counselling and a subset that do not. Any such findings could be incorporated into the pathways as an additional decision, determining the appropriate treatment regime of patients. This assessment might also help in improving the counselling recommended in the package.

Two other aspects of research that will influence the clinical package also require investigation. They are: (a) Follow-up of all patients to reveal whether OAD in some patients progresses into conventional auditory pathology. It might then be possible to identify certain indications of this, visible at the patient's initial visit. Any such findings would require incorporation into the decision pathways. (b) Investigation of sensory cognitive and psychological factors additional to those in the stage II battery, to reveal (or otherwise) other important factors in OAD. Tests for any such factors would then be added to the recommended battery. Additional factors to measure could include a simpler linguistic test, other personality measures, e.g. extroversion/introversion, general health questionnaire, and a hypochondriasis scale.

Further research at the Institute of Hearing Research will be directed towards these problems.

CHAPTER 5

5.1 INTRODUCTION

In section 1.2.2.3(a) the literature linking personality factors to the seeking of medical attention showed that anxiety and introversion were positively associated with report of symptoms. Consistent with this is the finding that in stages I and II OAD patients were found to be more anxious (especially in respect of phobic anxiety) than their matched controls.

The use of a second control group, of patients with symptoms in some other sphere but of unconfirmable organic origin, offers the possibility of studying the relevance of anxiety to OAD. It would enable investigation of whether there is a dissociation between psychological factors underlying referral as such, and psychoacoustic/cognitive factors contributing to a genuine disability and hence to objectively justified referral. Thus it was decided to test a second group of individuals seeking medical attention for a possibly 'non-organic' complaint in another sphere on the OAD stage II test battery, with the purpose of learning whether the personality traits distinguishing OADs from their matched controls were also present in the second group of patients.

5.2 LITERATURE REVIEW

A syndrome that seems to have many parallels with OAD, documented for about 100 years, has been variously labelled as the 'syndrome of pelvic congestion and

fibrosis' (Taylor, 1949), 'pelvic sympathetic syndrome' (Theobald, 1951), 'enigmatic pelvic pain' (Editorial BMJ, 1978), and 'chronic pelvic pain without obvious pathology - CPPWOP' (Renaer, 1981). For ease of reference the most recent term 'CPPWOP' will be used below. Patients are women who complain of lower abdominal pain. It tends to be localised to one or both iliac fossae (the areas to the left and right, below the uterus), or be generalised to the whole of the lower abdominal area. Gynaecological investigation, using conventional examination techniques, including laparoscopy, fails to identify any acknowledged cause of the pain. There have been various explanations for the syndrome, such as traumatic laceration of the supporting structures of the uterus (Allen & Masters, 1955), circulatory disturbances (Jeffcoate, 1975), and structural or functional modifications of internal genital organs (Taylor, 1949). However, after a review of the literature, Renaer et al (1980) felt that there was no clear-cut organic explanation for the syndrome and so investigated the psychological factors involved.

Renaer et al (1980) tested 3 groups of individuals: (I) 24 CPPWOP patients, (II) 22 patients with pain of a gynaecological organic basis, and (III) 23 control patients with minor documented gynaecological organic pathology but without any pain. The patients underwent various tests of a psychological nature. The results showed that: groups (I) and (II) (i.e all individuals experiencing pain) did not differ in psychological profile from each other in terms of their high neuroticism, but did differ from group (III) (the non-pain group). In addition, an evaluation by psychiatrists found group (I) patients to be more neurotic than individuals who had consulted a gynaecology clinic for

voluntary sterilisation (i.e. individuals with no pathology or pain, but who had sought treatment and were willing to undergo an operation). In a second empirical study using groups similar groups to those of Renaer et al, Castelnovo-Tedesco & Krout (1970) found that: group (I) patients were depressed and detached, as compared to normals. Group (I) and (II) patients had elevated scores on almost all scales of the Minnesota Multiphasic Personality Inventory - MMPI (a multi-scale inventory of psychiatric symptoms), as compared with group (III), in particular they had higher hypochondriasis, hysteria, paranoia and schizoid scores. In a third study (Beard et al, 1977), three groups of individuals were studied, two groups were analogous to groups (I) and (II) above, the third was a control group without any medical complaints. In addition to extensive gynaecological investigation, patients were given the Eysenck Personality Inventory (EPI) for neuroticism and extroversion, the MHQ (see section 2.3.3.4a) and a psychosocial questionnaire. They found that group (I) patients were significantly more neurotic than the controls; group (II) patients fell mid-way between, and were not significantly different from either of the other two. Group (I) patients also had less positive attitudes towards themselves and their partners than did the control group.

In summary, all three studies report that CPPWOP patients (lower abdominal pain in the absence of organic pathology) have more psychiatric symptoms than individuals not experiencing pain. However, in two of the studies, the CPPWOP patients are indistinguishable, in terms of psychological profile, from patients experiencing pain with organic pathology. It is important not to interpret findings such as the above as implying that every patient with no identifiable organic pathology

and greater than average anxiety levels should be viewed as simply neurotic. Renaer (1981) suggests that patients with CPPWOP constitute a heterogeneous group, made up of a spectrum of miscellaneous conditions. At one end of the spectrum are individuals with very little organic basis to their pain, in whom psychological factors play a major role, while at the other end are individuals with a greater degree of organic symptoms, and fewer psychological bases. Such a picture is highly consistent with that found in stages I and II for OAD.

Individuals with CPPWOP were found to be accessible, and so were used as subjects in this study to investigate the hypothesis that high anxiety levels, and general concern over health are common to all patients seeking help for non- or mildly-organic illness. Obviously this control investigation is restricted to women. An attempt to recruit men with 'non-organic' back-pain was unsuccessful.

5.3 METHOD

Subjects and Procedure

The gynaecology department of the University Hospital of Nottingham provided the names and addresses of about 40 women with possible CPPWOP. From the limited information available it appeared that appropriate gynaecological tests and laparoscopy had failed to find an organic basis for their lower abdominal pain. The women were each contacted by post inviting them to take part in the study. The letter explained the nature of the OAD study,

and why I was specifically interested in their taking part (see appendix 5.1 for letter). They were also sent a short questionnaire, checking that they did not have any obvious hearing difficulties. Fifteen women with CPPWOP replied and were able to take part. An additional 3 women replied in whom organic gynaecological problems had been identified; these were excluded from the sample. Some of the original group of 40 women were possibly also wrongly contacted (i.e were not CPPWOP patients) and so did not reply to the letter.

All fifteen subjects underwent the OAD stage 2 test battery, in exactly the same way as the matched controls in stage II. They were paid for taking part, and their travel expenses were paid.

5.4 RESULTS

For analyses, the patient controls were retrospectively matched on age, educational level and noise exposure to a sub-sample of 15 female OADs. Ages were matched to within 7 years, educational level to within 2 levels (see section 2.3.1), and noise exposure to within 1 NIR level. Data from the controls matched to the sub-sample of 15 OADs were also analysed. This group are called 'random controls' for this chapter, to distinguish them from the group of patient controls. Figure 5.1 gives a diagrammatic representation of these sub-samples.

There were no significant differences between patient-controls and the OAD small sub-sample on any of the matching variables (age, sex, educational level and noise

Figure 5.1 Diagrammatic Representation of OAD, Matched Control and Patient Control (Sub-) Samples

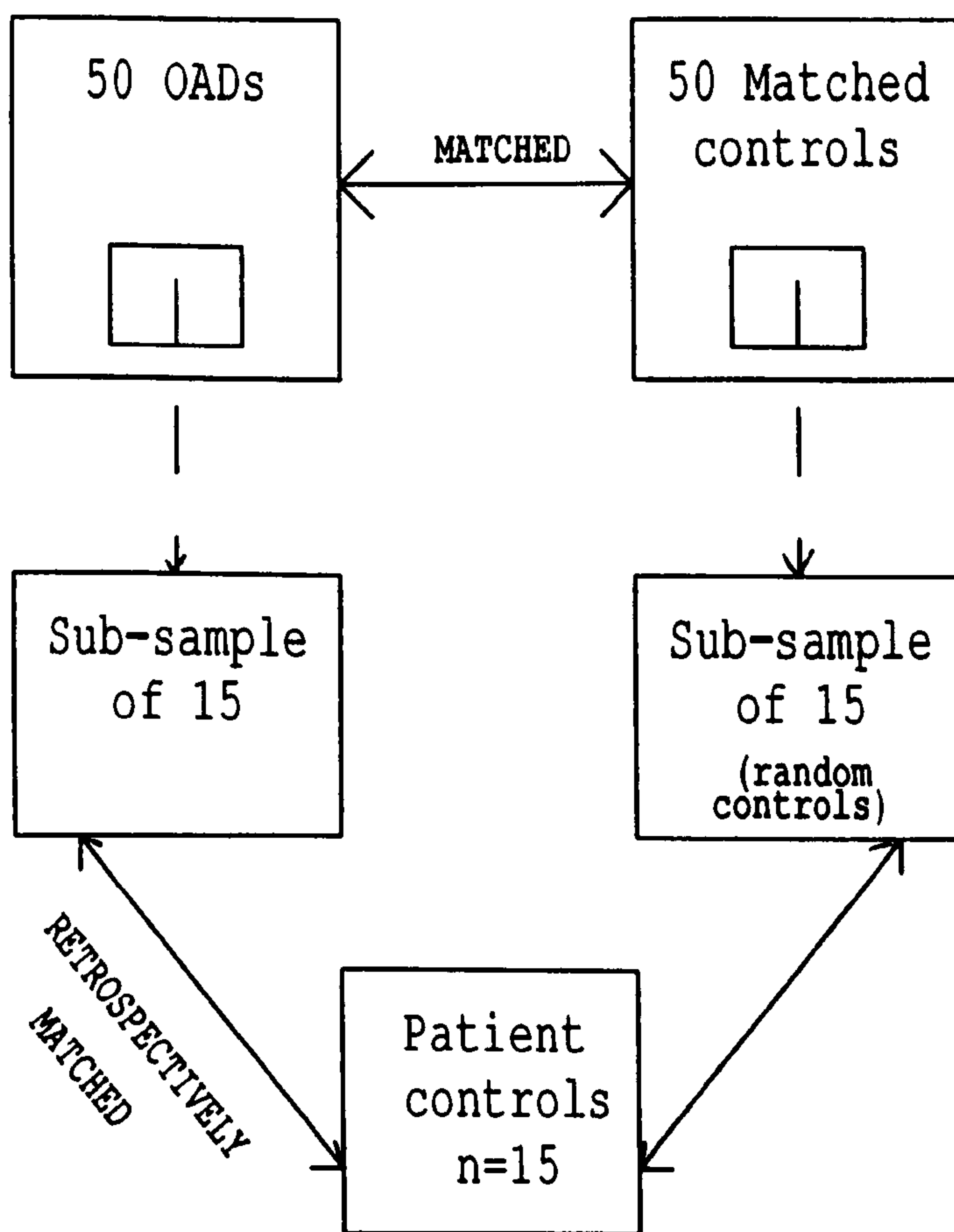

exposure history). The corresponding analysis with patient-controls versus the 15 random-controls also showed no differences. This shows that, although retrospective matching is necessarily imperfect, in this instance it was adequate, and group differences on other variables are not due to inadequate matching.

5.4.1 Homogeneity of OAD and Random-Control Sub-Samples

(a) Comparison of the OAD and Random-Control Sub-Samples with the Remainder of their Sample

The sub-sample of 15 OADs were compared with the remaining 35 OADs. The small sub-sample were all female and slightly but nonsignificantly older than the remainder of their group. Age and sex were, therefore, used as covariates when comparing the two sub-samples on continuous variables. The two sub-samples were found to differ on six variables: a greater number of OADs in the small sub-sample reported experiencing tinnitus, and having a family member with ear disorder, more found loud noises unpleasant, and more were regular smokers (table 5.1). On psychoacoustic variables the small sub-sample had marginally worse low-frequency masked thresholds (for one of the two replicates only) and significantly worse BMLDs than the remaining 35 OADs, even after age and sex had been accounted for with ANCOVA (Low-frequency masked threshold: $F=4.09$, $p<0.05$; BMLDs: $F=4.17$, $p<0.05$). On all other psychoacoustic, cognitive, psychological and performance variables the groups did not differ.

Table 5.1 Chi-square analyses for the small sub-sample of OAD patients (n=15) with the remaining OADs (n=35) on a variety of variables

Variable	χ^2 value	p
Tinnitus	6.5	0.01
Familial ear disorder	4.3	0.04
Intolerance of loud noises	5.8	0.02
Regular smoking	5.7	0.02

The 15 random-controls were next compared with the remaining 35. The small sub-sample (n=15) was found to have marginally higher depression ratings on the MHQ than the remaining controls, and to have marginally slower reaction time on the sentence monitoring task (depression score: $F=3.93$, $p<0.05$; Mean reaction time: $F=4.10$, $p<0.05$). On all other psychoacoustic, cognitive, psychological and performance measures the groups did not differ.

(b) Comparison of the OAD Sub-Sample (n=15) and the Random-Control Sub-Sample (n=15).

Univariate analyses were carried out to test whether the small sub-sample of 15 OADs differed from the random-controls on the same variables that distinguished the remaining OAD population (n=35) from their matched controls. Two-way ANCOVAs (correcting for age and sex)

showed that compared with the remaining patients (n=35), OADs in the small sub-sample (n=15) were comparatively worse than the sub-sample of controls on the performance SRTs, on the low-frequency masked threshold (one replicate) and in the size of their BMLDs. However, for all variables except the BMLD, OADs were significantly worse than controls for these comparisons within both sub-samples; only the magnitude of the difference varied. On all other variables, comparisons of OADs and controls within the two sub-samples were not significant. Table 5.2 shows group differences between the OAD sub-sample and the random-control sub-sample of anxiety scales.

Table 5.2

Means, standard deviations and t-tests between the OAD sub-sample (n=15) and the random-control group on some anxiety variables.

Variable	Sub-sample		t	p<
	OADs	Controls		
Phobic Anxiety	6.1 (2.8)	3.2 (2.9)	2.70	0.01
Somatic Anxiety	4.1 (2.5)	2.6 (2.4)	1.48	n.s
Combined anxiety ¹	5.0 (2.2)	3.7 (2.6)	1.58	n.s

¹Combined scale of general anxiety, phobic anxiety and somatic anxiety.

5.4.2 Comparison of Patient-Controls with the OAD
and Random-Control Sub-Samples

(a) Patient-Controls versus Random-Controls

Chi-square analysis showed that patient-controls had significantly higher scores on the phobic anxiety scale of the MHQ and marginally higher scores on the somatic anxiety scale than random-controls. Consequently they also had significantly higher ratings on the combined scale of general anxiety (Table 5.3). In addition, significantly more patient-controls than random-controls were regular smokers, (Regular smoking: $X^2=5.0$, $p<0.03$). Smoking and anxiety variables correlated highly within both groups (table 5.4). Marginally more patient-controls reported a childhood history of ear disorder (Childhood ear disorder: $X^2=3.34$, $p<0.07$). The combined scale of anxiety was a significant covariate of reported childhood history, the group differences were removed when it was taken into account with ANCOVA. This suggests that a psychological element may exist in the reporting of otological disorder (see discussion). Somewhat surprisingly, patient-controls had poorer mean low-frequency and mean mid-frequency pure tone audiograms than random-controls (table 5.3). These group differences were removed when history of childhood disorder was used as a covariate. This implies that the reporting of childhood ear disorder also has an otological basis, as well as a psychologically mediated element. On all other psychoacoustic, cognitive, psychological and performance variables the groups did not differ.

Table 5.3

Means, standard deviations and t-tests comparing patient-controls (n=15) and random-controls n=15) on a variety of variables

Variable	Mean score		t	p
	patient-controls	random-controls		
Phobic anxiety	5.3 (2.3)	3.3 (2.9)	-2.17	0.04
Somatic anxiety	4.5 (2.4)	2.7 (2.4)	-1.95	0.06
General anxiety	5.5 (1.8)	3.7 (2.6)	-2.24	0.03
AVMID ¹	10.8 (5.1)	7.0 (4.8)	-2.08	0.05
AVLOW ²	15.1 (5.2)	10.4 (6.2)	-2.27	0.03

¹Binaural average of thresholds at 0.75, 1.0 and 1.5 kHz

²Binaural average of thresholds at 0.125, 0.25 and 0.5 kHz

Table 5.4

Correlations of anxiety scales with smoking within the combined group of patient-controls and matched-controls. For n=30, p<0.05 if |r|>0.35

Variable	r	p <
General anxiety	0.50	0.001
Phobic anxiety	0.39	0.002
Somatic anxiety	0.43	0.002
Combined scale ¹	0.54	0.001

¹Combined scale of general, phobic and somatic anxiety

(b) Patient-Controls versus OAD Sub-Sample

The OAD sub-sample did not differ from patient controls on any scale of the MHQ, but did differ from patient controls on almost all auditory, cognitive, and performance variables, on self-rated auditory disability and handicap and on the number of individuals reporting tinnitus, finding loud noises unpleasant and having a family member with ear disorder; these differences were all in the expected direction, and in the same direction as differences between OADs and random-controls. There were two psychoacoustic variables on which OADs did not differ from the patient-controls, in the expected manner. These were frequency resolution, and one of the variables from which it is derived, the mid-frequency masked threshold (notch-condition).

In contrast to the expected direction of group differences, patient-controls had significantly worse low-frequency thresholds than OADs. This group difference remained significant after accounting for childhood ear disorder with ANCOVA. Patient-controls also reported marginally more childhood ear disorder than did OADs ($X^2=3.4$, $p<0.07$); this group difference in reported history did not diminish when anxiety was used as a covariate. OADs did not differ from patient-controls in terms of smoking habits.

Figure 5.2 gives a diagrammatic representation of the levels of anxiety on four scales of the Crown-Crisp questionnaire and on the combined anxiety scale. A hierarchy of levels can be seen: patient-controls are the most anxious group, followed by OADs and then least

Figure 5.2 Scores of OADs, Patient-Controls and Random-Controls on 4 scales of the Crown-Crisp Questionnaire

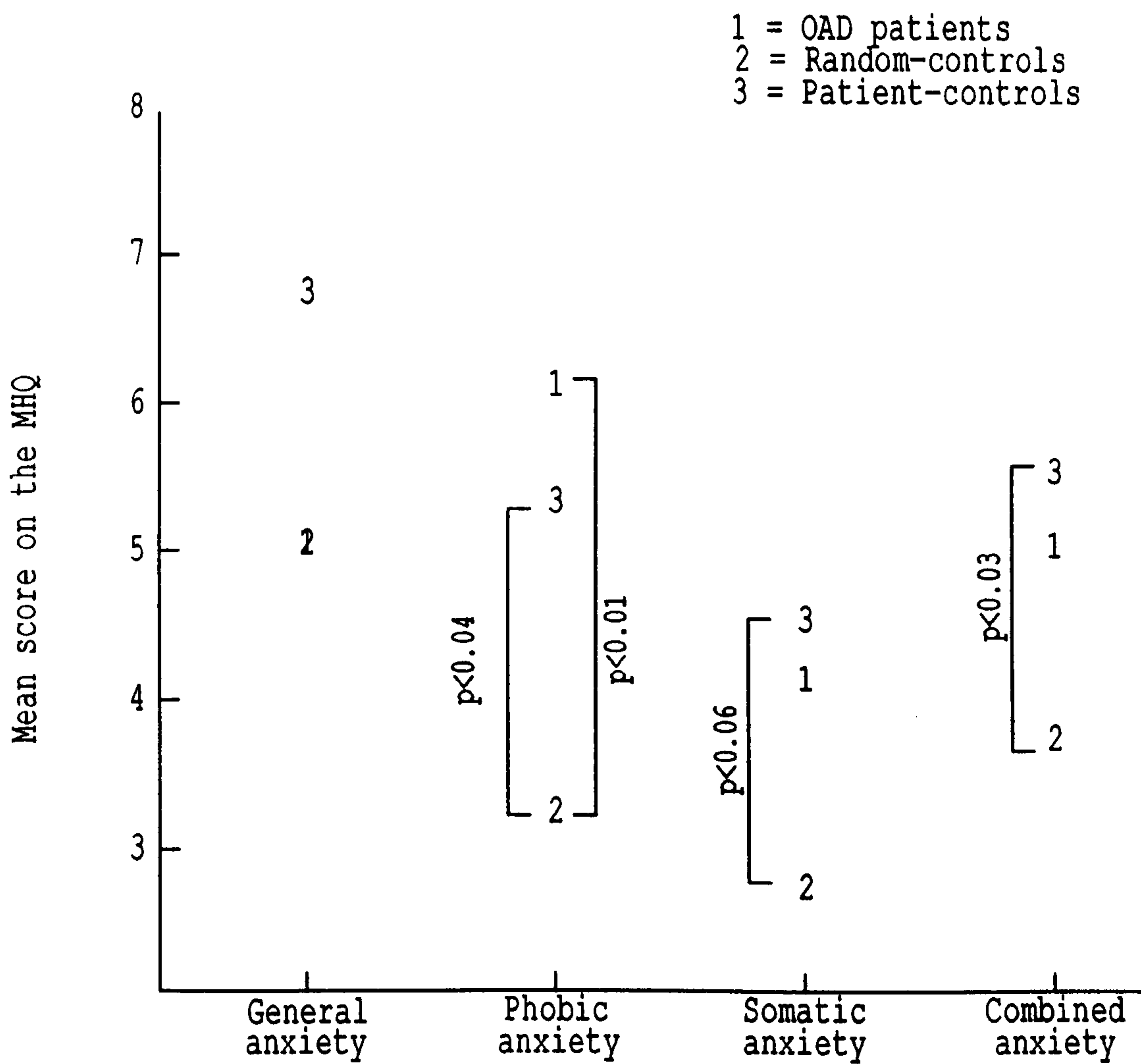

anxious are random-controls. OADs do not differ from patient-controls on any anxiety scale, but both groups differ from random-controls on one or more anxiety scales.

5.5 DISCUSSION

5.5.1 Homogeneity of the OAD and Random-Control Populations

Comparison of the small sub-sample of OADs with the remaining OADs, and of the small sub-sample of matched controls with the remaining matched controls shows that the sub-samples did not differ substantially from one another, i.e the sub-samples resulting from matching with the patient-controls were representative of their whole samples. This has two important implications. First, it suggests that there is a fair degree of homogeneity within the OAD population, and that a sub-sample has broadly the same characteristics as the larger group. This is of significance for the clinical aspects of this thesis. Second, of direct relevance to this chapter, it suggests that the comparisons of the OAD and patient-control groups were representative, despite the relatively small numbers of female subjects involved.

5.5.2 Comparisons of OAD and Random-Control
Sub-Samples with the patient-controls

In general, patient-controls differed from random-controls on anxiety-based variables, and did not differ in terms of psychoacoustic, cognitive or performance abilities; in addition, patient-controls smoked more than random-controls. The high correlation between smoking and anxiety variables shows this to be an anxiety-related behaviour. These findings demonstrate a double dissociation, as anticipated, i.e (i) the auditory capabilities of the patient-control group were comparable with those of the random-control population; (ii) anxiety and anxiety-related behaviour differentiates patient controls from random controls, as hypothesised. It is important to note, however, that this conclusion is only justified for this particular set of tests, and that other group differences could be found on a non-auditory set of tests. There were just two unexpected results: (i) patient controls had significantly worse mean low-frequency and mean mid-frequency audiograms than random controls, and (ii) more patient controls than random controls reported a history of childhood ear disorder. As pointed out in section 2.5.5, reports of childhood ear disorder were not validated externally, leaving unclear the influence of personality on recall and report of such disorder. The reduction of the patient-control/random-control group difference in reported childhood ear disorder for anxiety as a covariate demonstrates the close relationship between these variables; this finding was also present in stage I. However, childhood ear disorder among the patient-controls also appears to have a genuine basis causing material impairment. This is shown by the fact that group differences in low- and mid-frequency thresholds were removed when reported

disorder was used as a covariate. These findings suggest that childhood disorder can lead to mild low-frequency losses in adulthood.

OADs, on the other hand, differed from patient controls on most psychoacoustic, cognitive and performance variables in the expected direction, but did not differ on anxiety-based ones, nor in smoking habits. This once again confirms that patient-controls have 'normal' auditory function, and that anxiety is related to the status of patient. The three exceptions to this were: (i) no group difference in frequency resolution or mid-frequency masked threshold, (ii) poorer low-frequency audiograms among the patient controls and (ii) more reports of childhood ear disorder by patient-controls. In these groups anxiety level did not remove group differences in reported childhood ear disorder. This is not surprising in view of the groups being equally anxious. It also suggests that their reports were influenced by similar factors. The group differences in low-frequency audiogram did not diminish when history of ear disorder was taken into account as a covariate, suggesting that low-frequency threshold differences are not due to childhood ear disorder.

In conjunction with the finding that OADs are more anxious than random-controls, the following can be concluded. First, that individuals seeking medical attention for non- or minor-organically based symptoms are more anxious than individuals who have not sought medical attention. Second, that the former individuals are more similar to each other in terms of anxiety levels and anxiety-related behaviour, than they are to the latter group of individuals, even though the symptom focus of their complaints is very different. It is

interesting that the phobic anxiety scale best differentiates the patient groups from the random-controls. Phobic anxiety is the fear of specific situations (e.g. enclosed spaces, heights, illness) and so this result is not at all surprising. It is also in accordance with work by Gochman & Saucier (1982) and Mechanic (1980) showing that the seeking of medical attention is influenced by an individual's perceived vulnerability to that illness; it follows that highly phobic individuals might fear illness and hence feel more vulnerable to illness than less phobic individuals.

From these results it is not possible to be certain of the way in which anxiety is acting to prompt the patients to seek attention. The three main possibilities are: (a) anxiety is a psychosomatic cause of pathology via the sympathetic nervous system, or (b) anxiety among the patients is a result of their worrying about symptoms they have been experiencing; or (c) anxiety is a pre-existing factor triggering the patients to obtain the status of patient at a marginal level of symptoms. It is unlikely that (a) is the explanation, since the two groups report considerably different symptoms. If (b) were true it might explain why patient-controls are more anxious than the OADs, as follows. Pain in the pelvic region is often associated with life-threatening conditions, such as cancer, whereas hearing loss is unlikely to be life-threatening. Patient-controls, therefore, might have become more anxious, relative to OADs, about the symptoms they are experiencing. However, the only sure way to dissociate these three explanations would be via a prospective longitudinal study, in which a large sample of individuals, initially with no complaints in the sphere of interest, are examined, tested and interviewed regularly and carefully documented as to

anxiety level. This population would then be followed up to see who developed symptoms, with and without an organic basis.

5.6 SUMMARY AND CONCLUSIONS

The use of the patient-control group has demonstrated that there is a dissociation between psychoacoustic and cognitive factors in OAD and the influence of personality. More generally this finding reinforces the importance of considering some aspects of personality when investigating and treating certain types of symptom. However, every patient of anxious nature should not be simply labelled as neurotic, as shown by the finding of organic pathology in OAD.

CHAPTER 6

6.1 INTRODUCTION

This chapter does not present new data, but examines the data collected during stage II of the project from a different perspective. More precisely it examines relationships (a) amongst and (b) between psychoacoustic, cognitive, personality-related and performance variables; and how these relate to self-rated auditory disability and handicap. These latter issues give an understanding of the auditory disability/handicap arising from different degrees and types of peripheral and central auditory function, and hence can be of use when devising appropriate assessment and management. Tackling the former issues can give us insight into the inter-relationships of different functions within the auditory system. We can learn the level of measured impairment and performance disability beyond which individuals begin to notice disability; from this information the criterion of 'normality' can be set. Historically this has been relevant to the design of schemes for dealing with claims for industrial compensation. Since claimants might be inclined to exaggerate the disability they experience, the scale of reported disability needs to be standardised by means of performance measurement on non-claimants.

The data collected during this project offer an appropriate way of tackling the above issues, for a number of reasons. First, correlation studies require large numbers of cases in order that the results be generalisable; the number of cases with full data from the OAD stage II test battery is quite large (n=115, OADs, matched controls and patient controls). Second, a comprehensive understanding of relations between

functions in the auditory system requires measurement of many different types of function; the data here embrace diverse measures of auditory ability. Thirdly, relations between auditory functions have been fairly extensively investigated among hearing-impaired populations, but less well investigated among normally hearing individuals. Studies using normally hearing individuals have had largely null findings (e.g Festen & Plomp, 1983); this data set can be used to confirm the conclusions of such studies, or otherwise.

In section 6.2 correlations between *self-rated* disability/handicap and measured disability are discussed. In section 6.3 the correlations between *performance* measures and psychoacoustic, central/cognitive and personality-related factors are covered.

6.2 RELATIONS BETWEEN SELF-RATED AUDITORY DISABILITY/HANDICAP AND PSYCHOACOUSTIC, COGNITIVE AND PERSONALITY-RELATED VARIABLES

6.2.1 Literature Review

As mentioned in section 2.2.1(a) there are numerous self-report scales to assess auditory disability and handicap. (See Stephens, 1987 or Noble, 1979 for review). These scales have two purposes. First they are convenient for the quick assessment of an individual's auditory difficulties, and hence, in a clinical setting, they can rapidly cover much of the assessment required prior to

management of that individual in a standardised fashion. Second, they can be used to provide group data in research studies. Many studies show only modest correlations between self-assessed auditory disability/handicap and most objective measures of impairment or disability (e.g. Demorest & Walden, 1984; Hagerman, 1984, Rowland et al, 1985), although recent reports by Lutman et al (1987), and Rudin et al (1988) have shown some stronger relationships. The magnitude of the correlation appears to depend on the range of hearing sensitivity in the sample and on the variables measured.

Some research using self-assessment questionnaires has been aimed at determining what measure of impairment best relates to self-assessed disability. However, the majority of studies have compared measures of pure tone sensitivity with performance measures, e.g. the understanding of speech in quiet or in noise. This information can be used to determine which performance measure best aligns with reported disability. The results are somewhat equivocal. For instance, Demorest & Walden (1984) found self-assessed disability to correlate better with speech discrimination than with pure tone threshold, Schow & Tannahill (1977) reported the opposite result, while Tyler & Smith (1983) found little difference between the two. In a publication relating other psychoacoustic measures to self-assessed disability/handicap, Lutman (1983) found that frequency resolution ability did correlate with self-assessed disability/handicap, but that the correlation disappeared once pure tone sensitivity had been taken into account.

Self-assessment questionnaires have also been used to determine the degree of auditory impairment beyond which disability is noticed. One aim of such work is to define

an appropriate cutoff point of 'normality' of pure tone thresholds. Early work suggested a "low fence" of between 25 and 30dB (see Robinson et al, 1984 for a review). Parving & Ostri (1983) investigated a variety of different criteria of normality as defined by pure tone sensitivity. They found that the definition of pure tone thresholds of < 20dB at frequencies of 0.5, 1.0, 2.0 and 4.0kHz best corresponded with a positive report of disability on a questionnaire. The questionnaire used in that study was later validated by the finding that the mean speech-in-noise discrimination scores of individuals reporting auditory disability were significantly lower than those of individuals not reporting disability (Parving et al, 1986). Suter (1978), Smoorenburg et al (1982) and other authors have suggested that a low-fence in the range 15-19dBHL was more suitable. The most recent data from Smoorenburg (1986), have shown a relationship between pure tone sensitivity and speech-in-noise performance apparently extending down to 0dBHL, and suggest that from the point of view of preventive medicine, hearing losses of 10dB or greater (for an average of 2 and 4kHz) should be prevented in order to avoid material auditory disability. Lutman et al (1987) computed various pure tone averages using different combinations of frequencies and studied their correlations with 4 sub-scales of a hearing questionnaire. They found strong relationships between pure tone averages and self-rated disability for everyday speech, and between pure tone averages and self-rated handicap. The specific combination of low- to mid-frequency thresholds used to compute the average was of little importance. They also reported that a pure tone average of 15dBHL (for 0.5, 1 and 2kHz) is significantly disabling for everyday speech discrimination. Significant self-rated handicap occurred at losses of between 12 and

20dB, depending on the type of hearing loss (conductive/mixed losses causing greater handicap than sensori-neural losses of equal magnitude). More recent analyses, however, have shown this latter finding to be due to the confounding effects of age (Lutman, personal communication). Most importantly, they stress that the cut-off point at 15 dBHL (or anywhere else) for onset of disability has an arbitrary basis, since there is no sharp knee-point in the disability/impairment function at which there is a clear onset of disability. The function is continuous.

Throughout this project the influence of non-sensory variables on self-rated auditory disability/handicap has been emphasised. OAD patients are a group in which those variables play a particularly important role, in the sense that their self-rated disability/handicap seems to be of far greater magnitude than that which would be expected from their relatively slight measured impairment and disability. However, a causal link between self-rated disability/handicap and measured impairment still exists, to a greater or lesser extent, in any individual. The following paragraph is a short review on previous work regarding non-sensory variables.

For a given audiometric average, the subject's age is known to relate paradoxically (i.e negatively) to self-rated disability. Merluzzi & Hinchcliffe (1973) for example, found that older individuals had greater losses than younger ones when the loss was first noticed. Similarly, Lutman et al (1987) report that for a given level of impairment, older individuals report less disability/handicap than younger ones.

In two epidemiological studies, men have been found to report more disability than women. Lutman et al (1987) report this for individuals with a sloping sensorineural loss; accounting for high frequency sensitivity only partially explains this difference. Rosenhall et al (1987) found this among a group of 70- to 80- year-olds. However, actual hearing sensitivity was not taken into account in the latter study, the finding, therefore might be due to the men in their sample having genuinely worse hearing.

Lutman et al (1987) did not find a relationship between socioeconomic status and self-reported disability, although Davis (1983b), reports that socio-economic status is positively correlated with complaints about hearing speech in a noisy environment. These results, however, are not partialled for the effects of actual hearing ability. Similarly Stephens (1987) postulates that sociological and vocational factors are bound to influence the degree of loss at which disability and handicap are first noticed.

A study of the elderly by Marcus-Bernstein (1986) found that in addition the contribution of audiometric measures, self-assessed handicap was associated with having few and unsatisfactory social contacts, loneliness, depression, lethargy and paranoia; a similar pattern of results was reported by Jones et al (1984). However, in both of these studies, individuals had hearing losses. It is not possible, therefore, to conclude to what extent self-ratings were a direct result of actual hearing loss as opposed to psychological variables.

From this literature review it can be concluded that reported disability/handicap does relate to at least some auditory functions. If these past findings are a true reflection of function in the auditory system in general, and are not too tied to the particular test measures and populations used, a similar pattern of correlations should exist within the data set here. The following paragraphs summarise the correlations expected from the past literature.

6.2.2 Expected Relationships

6.2.2.1 Psychoacoustic Correlates

In table 6.1 is a summary of the relationships which past research theoretically suggests might exist between psychoacoustic variables and self-rated disability and handicap within this data set.

Table 6.1
Summary of expected relationships between psychoacoustic variables and self-rated disability/handicap

	Everyday speech	Localisation	Speech-in-quiet	General disability	Auditory handicap
Speech-in-noise	- - -	- -		- - -	- - -
Pure tone sensitivity	+		+	+	+
Low-freq. masked threshold	- -			- -	- -
High-freq. masked threshold	- -			- -	- -
Frequency resolution	- -			- -	- -
BMLD	-	- - -	-	-	-
Temporal resolution	- -		- -	- -	- -

- represents small negative correlation, - - represents moderate negative correlation, - - - represents strong negative correlation, and + represents a small positive correlation.

Self-rated disability should ideally be a direct and accurate reflection of actual disability, although as discussed below (section 6.2.2.3) there are circumstances in which this is not the case. Assuming it to be true, however, any psychoacoustic ability influencing speech comprehension (especially speech comprehension in noise) is likely also to influence general self-rated disability. In particular, frequency resolution and

temporal resolution ability, both of which relate to discrimination of speech-in-noise, should correlate negatively with self-rated disability, while BMLDs, reflecting binaural processing skills, should correlate negatively with disability for localisation. Pure tone sensitivity is a relatively poor correlate of speech comprehension among normally-hearing listeners and so probably will not correlate strongly with self-rated disability. Aniansson (1974) showed that speech discrimination in everyday listening situations required normal hearing up to 3kHz and that losses above 2kHz caused significant auditory disability for performance on a speech test. This demonstrates the importance of high-frequency acuity for speech discrimination in noise, and suggests that speech-related disability will correlate better with high frequency measures than low-frequency ones. Theoretically it is likely that individuals base their rating of auditory handicap upon the more difficult listening conditions (such as speech-in-noise), hence, those variables correlating well with disability for speech-in-noise should also correlate well with self-rated auditory handicap.

6.2.2.2 Central/Cognitive Correlates

Central/cognitive abilities are required for the processing of complex auditory stimuli such as speech, and in particular speech in noise. Lipreading ability, therefore, should correlate with reported auditory disability for speech and with auditory handicap, in situations where visual clues are available. A similar result might be expected for performance on all

conditions of the dichotic listening test and on the sentence-monitoring test of linguistic ability. In addition, the dichotic listening test requires binaural separation abilities, so performance on this should also correlate with disability for localisation.

6.2.2.3 Personality-Related Correlates

When considering personality-related correlates of reported disability/handicap the assumption that reported disability/handicap reflects actual disability/handicap should be questioned, since it is likely that personality-related variables influence these ratings, irrespective of performance. The literature reviewed above suggests that certain personality factors, such as anxiety and depression, will be positively correlated with self-ratings of disability/handicap, as might be past history of ear disorder.

The correlations between self-rated auditory disability/handicap and variables in all the three domains investigated in stage II (psychoacoustic, cognitive and personality-related) were studied. All individuals that took part in stage II were combined into a single group for analysis. Elsewhere in this thesis, where relevant, correlations within the groups are referred to (e.g. tables 3.6, 5.4).

6.2.3 Method

Data from all subjects (OADs, matched controls and patient controls) in stage II of the study were analysed. Subscales from the IHR hearing questionnaire were computed as in Lutman et al (1987) - details are given in appendix 6.1. The resulting sub-scales are:

- (a) Everyday speech disability
- (b) Disability for speech in quiet
- (c) Disability for localisation of sound
- (d) General auditory disability = (a) + (b) + (c)
- (e) Auditory handicap

Histograms of each continuous variable were plotted to check the data were normally distributed. (Appendix 6.2 contains these histograms). Two sets of raw and partial correlations between the hearing questionnaire sub-scales and the main variables from stage II of the study were carried out. In the first set, all data values were analysed. In the second set, extreme values (outside +/- 2.5 SDs from the mean) were excluded. This was done to ensure that correlations were not based on just one or two extreme data points. The data presented in the following tables are from the second set of analyses.

6.2.4 Results and Discussion

6.2.4.1.1 Results: Psychoacoustic Correlates of Self-Rated Disability and Handicap

Table 6.2 shows partial correlations between self-rated disability, psychoacoustic measures, and performance on the PFFIN test. Histograms in appendix 6.2 show that all psychoacoustic measures were normally distributed; there were very few extreme values. Re-analysis of the data excluding these values confirmed that correlations were not mediated by these values alone.

The replicates of the low-frequency masked thresholds were averaged before analysis, as were the two conditions of the mid-frequency masked thresholds. This action was justified by the finding that correlations between these computed variables and reported disability/handicap remained similar or increased when compared to using the individual replicates.

Some psychoacoustic variables (e.g. masked thresholds) are highly correlated with pure tone thresholds and with age (e.g. gap detection thresholds). Accordingly all correlations presented below are partialled for age and pure tone sensitivity¹ (average audiogram). However, in almost all cases partialled correlations differed only slightly from the raw correlations. It must be expected that all correlations will be low, relative to those that

¹Except those between self-rated disability/handicap and average audiogram. These are partialled for age alone.

would have been found if a population with a full range of hearing impairments were used. Nevertheless, about half of the tabulated correlations are significant, even if relatively small.

Table 6.2

Correlations between self-rated disability/handicap and psychoacoustic variables, after partialling for age and average pure tone sensitivity
For n=110, $p < 0.05$ if $|r| > 0.19$

	Everyday Speech	Localisation	Speech-in-quiet	General disability	Auditory handicap
PSRTN (n=113)	-0.38	-0.35	-0.03	-0.40	-0.27
PSRTB (n=112)	-0.24	-0.24	0.04	-0.27	-0.18
Average audiogram (n=114)	0.14	0.13	0.09	0.17	0.10
Frequency resolution (n=111)	-0.17	-0.12	-0.15	-0.19	-0.10
*Low-freq. (n=111)	-0.34	-0.29	-0.16	-0.36	-0.37
*Mid-freq. (n=113)	-0.31	-0.27	-0.25	-0.34	-0.26
BMLD (n=114)	-0.05	-0.08	-0.02	-0.08	-0.13
Gap threshold (n=112)	0.24	0.23	0.18	0.28	0.28

* = masked thresholds

In all cases the independent variables were correlated more significantly with general disability than with any component sub-scale of disability. This is probably

because the number of questions in the general disability scale is greater, and hence, the reliability of the scale is increased.

As predicted in table 6.1, discrimination of speech-in-noise (PSRTN) was correlated with reported disability for everyday speech and with general disability; but it was also correlated equally (rather than less so, as postulated) with reported disability for localisation, this probably reflects the binaural nature of the PFFIN test. In view of the substantial correlation between the PSRTN and everyday speech disability, the PSRTN was expected to correlate more highly with reported handicap than it did. The pattern of correlations for the PSRTB was similar to that of the PSRTN, except that correlations were generally lower.

Pure-tone sensitivity did not correlate significantly with any self-rating scale, not even with disability for speech-in-quiet. All correlations were so low that it would not have been profitable to compare correlates of high- and low-frequency averages.

Surprisingly, frequency resolution did not correlate significantly with any self-rated scale. The specific sub-scale in which the correlation neared significance was between frequency resolution and disability for everyday speech ($r=-0.17$, $p<0.075$), for which a moderate correlation was predicted.

Both low- (500Hz) and mid-frequency (2kHz) masked thresholds correlated moderately well with reported disability for everyday speech (including speech-in-noise), but less well with reported disability for

speech-in-quiet, as predicted. Mid-frequency masked thresholds appeared to correlate better than low-frequency thresholds with reported disability for speech-in-quiet; this difference in magnitude, however, was not significant (Fisher $Z=0.54$, n.s.). Masked thresholds also correlated significantly with auditory handicap, as predicted.

BMLDs did not correlate significantly with any self-rating scale, not even with disability for localisation, for which a high correlation was predicted.

As expected, gap detection thresholds correlated moderately well with all self-rated disability and handicap scales, except for speech-in-quiet. The relationship between gap detection and auditory handicap was strongest.

6.2.4.1.2 Discussion: Psychoacoustic Correlates of Self-Rated Disability and Handicap

Of the component reported disability measures, PSRTs correlated best with disability for everyday speech. There was a significantly higher correlation of the PSRTN and the PSRTB with disability for speech-in-noise than for speech-in-quiet (PSRTN Fisher $Z=8.90$, $p<0.001$; PSRTB Fisher $Z=2.48$, $p<0.025$). This lends some credence to the specific content of the questionnaire reports, vis-a-vis speech-in-quiet versus speech-in-noise, at least for this range of hearing levels. The low correlation of the PSRTs with disability for speech-in-quiet confirms Festen & Plomp's (1981) finding that factors associated with

speech-in-quiet differ from those associated with speech-in-noise. The relationship between the PSRTs and disability for localisation may lie in the pseudo-free-field recording of the performance test, since stereophonic processing of free-field sounds requires the use of the same binaural cues as localisation.

The relatively slight relationship of the PSRTs to self-rated handicap may appear somewhat surprising, but is consistent with other studies for speech-in-noise performance (e.g. Blumenfeld et al, 1968; Speaks et al, 1970). Self-rated handicap was clearly not based upon performance alone. This was also seen in Lutman et al's (1987) study, in which age and sex were found to influence ratings of auditory handicap.

It is not immediately clear why the PSRTB correlated less well than the PSRTN with all disability/handicap scales. The explanation might, in part, be that there is less across-subject variance in PSRTB as compared to PSRTN (PSRTN variance: 9.9, PSRTB variance: 3.6).

The absence of significant correlations between pure tone sensitivity and self-rated disability is in contrast to much literature, for example, Lutman et al (1987), Demorest & Walden (1984) and Tyler & Smith (1983). However, all of these studies included individuals with a range of hearing abilities. The correlations here were not significant, probably because all subjects had 'normal' hearing, and hence there was little variation in their thresholds. This suggests that pure tone sensitivity is not a good predictor of the self-reported auditory disability that can be found in the presence of minor auditory dysfunction.

An alternative predictor of auditory disability/handicap was suggested by Pick & Evans (1983) in the form of a measure of frequency resolution; however their suggestion is not supported here. The absence of correlations between frequency resolution and all self-rated scales is also surprising in view of theoretical literature suggesting that processing of speech-in-noise requires good frequency resolving ability (see Gelfand, 1981 for review), and in view of some empirical studies supporting it (e.g. Tyler et al, 1982(a); Dreschler, 1983; Stelmachowicz et al, 1985). The findings here might be due in part to low reliability of the particular measure of frequency resolution, since it is derived from two other measures; hence, despite removing the individual covariance, it combines two sources of measurement uncertainty. This is unlikely to be the only explanation, however, because in stage 1 of the study there was also no correlation between frequency resolution and self-rated variables. The measure of frequency resolution used for stage 1 was different from that used here, yet the correlations between self-reported disability/handicap and frequency resolution were also null (Frequency resolution with disability: $r=0.010$, n.s.; with handicap: $r=0.13$, n.s.). A second explanation might be that, because frequency resolution and pure tone sensitivity are generally closely related, there was relatively little variance in frequency resolving ability in this normally-hearing population, and hence correlations between frequency resolution and other variables could not emerge. Some evidence for this comes from the finding that the within group variance of frequency resolution is similar to that for left versus right ear replicates (Within group variance: 18.6; left-right variance: 26.5). Further support for this notion comes from Festen & Plomp (1981) who found no correlation between frequency

resolution and pure tone sensitivity in a normally-hearing population, but did in a hearing-impaired population (Festen & Plomp, 1983). Secondly, Tyler et al (1982a) point out they were unable to distinguish the exact relationship between speech intelligibility in noise and frequency resolution because they both correlated highly with pure tone sensitivity. Finally, Lutman (1983) found no correlation between frequency resolution and self-rated disability within a hearing-impaired population, once pure tone sensitivity had been partialled.

Masked thresholds correlated well with reported disability for everyday speech; this is consistent with psychoacoustic theory, and also explains why they correlated well with reported handicap.

Gap detection ability was moderately well correlated with all self-rating scales. This reflects a non-specific influence on all types of auditory processing. Festen & Plomp (1981) using factor analysis similarly found temporal resolution (measured as the width of the temporal window) to be relatively independent of other clusters of variables. The strong relationship between gap threshold and auditory handicap is possibly understandable in terms of a central component in gap detection, a finding suggested in some neuropsychological literature (e.g Efron et al, 1983; Lackner & Teuber, 1973).

In summary, individuals' reports of, and hence presumably their experiences of, auditory disability that are accompanied by measurable disability for speech-in-noise, are related to some, but not all, basic psychoacoustic

abilities. Performance measures of speech-in-noise here were more effective than raw psychoacoustic measures at reflecting reported auditory disability. One reason for this might be because minor auditory pathology is caused by slight deterioration in many psychoacoustic abilities, the combined effect of which might cause poor performance. Impairment in a specific ability might be too slight to measure with a specific test of that ability. Alternatively, auditory performance might also be influenced by non-sensory variables.

One disadvantage of using a performance test in a clinical context to validate reports of auditory disability is that it would not specify the precise cause of that measured disability. Self-rated handicap in part also reflects measured disability, but appears to be influenced by other, non-sensory variables.

6.2.4.2.1 Results: Central/Cognitive Correlates of Self-Rated Disability and Handicap

Table 6.3 presents age-partialled correlations of self-rated disability and handicap with cognitive variables from all subjects in stage II of the study (n=115). The histograms in appendix 6.2 show the distributions of the central/cognitive variables. Re-analysis after excluding extreme scores altered the correlation only between lipreading and disability for localisation. The re-analysed results are presented.

Table 6.3

Correlations between self-rated disability/handicap and cognitive variables, after partialling for age.
For n=110, p<0.05 if |r|>0.19

	Everyday speech	Localisation	Speech-in-quiet	General disability	Auditory handicap
Lip-reading (n=111)	0.03	0.17	-0.01	0.06	-0.06
*Focus (n=111)	-0.25	-0.25	0.01	-0.25	-0.27
*Divide (n=115)	-0.22	-0.34	-0.02	-0.26	-0.22
*All (n=111)	-0.26	-0.32	-0.01	-0.28	-0.28

* = from dichotic listening test

The variables derived from the dichotic listening test are significantly and negatively correlated with age, while the remaining variables are not. Nevertheless, all correlations are partialled for the effects of age.

Linguistic ability did not correlate significantly with any reported disability sub-scale, so these results are omitted from the table.

Surprisingly, lipreading (as measured by the difference between the VSRTN and ASRTN) did not correlate significantly with any of the self-report sub-scales of disability/handicap.

Fisher Z-tests show that the correlations between different conditions of the dichotic test (focussed versus divided attention) and the different disability/handicap sub-scales were not significant. Therefore results are discussed in terms of correlations for the combined scores (row labelled '*All' in table 6.3). As predicted, the dichotic scores correlated moderately with all disability sub-scales except for speech-in-quiet. The former sub-scales include tasks that require central processing ability.

6.2.4.2.2 Discussion: Central/Cognitive Correlates of Self-Rated Disability and Handicap

Extreme linguistic deficits can cause auditory disability and handicap (Lubert, 1981). However, minor linguistic deficits that might exist within a sub-clinical population not reporting frank language symptoms are probably too small to cause material auditory disability on their own. This could explain why there was no relationship between self-rated disability and linguistic performance.

The unexpectedly poor relationship between lipreading and self-rated auditory disability (particularly for speech) might have occurred because the disability questions emphasised difficulties with 'hearing', rather than with 'understanding'. Some light could have been thrown upon this had the correlation between lipreading and self-reported disability for watching television (appendix 6.1, question 1) differed from that between lipreading and self-reported disability for listening to the radio

(appendix 6.1, question 2). However, in both instances the correlations were near zero, (question 1: $r=0.02$, n.s.; question 2: $r=0.01$, n.s.).

The finding that the dichotic scores correlated strongly with all the self-rating subscales (except speech-in-quiet) suggests that here dichotic listening ability reflects general central processing ability. This is supported by the finding that correlations increased slightly when scores from the two conditions were combined into a single variable. The slightly (but non-significantly) stronger correlation of the divided attention condition over the focussed attention condition with disability for localisation probably arose because both focussing of attention and localisation ability required the use of binaural listening skills, in particular binaural integration and separation. Disability for speech-in-quiet did not correlate with the dichotic listening variables, probably because processing of speech-in-quiet did not require any very complex central discrimination processes.

In summary, central processing abilities correlated with self-rated disability and handicap, confirming that reported auditory disability in normally-hearing individuals is influenced by non-sensory variables to a material extent. The range of central tests used was not sufficient to conclude whether central or peripheral variables play the major role.

6.2.4.3.1 Results: Demographic and personality-related correlates of self-rated disability and handicap

In table 6.4 are age-partialled correlations of anxiety and otological history with self-rated disability and handicap. Demographic variables (age and educational level) are omitted because no correlation reached significance. Data here are from all 115 subjects in stage II of the study. Once again the data presented are the re-analysed results after excluding extreme values (appendix 6.2).

Table 6.4

Partial correlations between self-rated disability/handicap and personality-related variables. For $n=115$, $p<0.05$ if $|r|>0.185$

	Everyday speech	Localisation	Speech-in-quiet	General disability	Auditory handicap
<u>General Anxiety partialled for age and:</u>					
None (n=114)	0.24	0.37	0.21	0.30	0.20
PSRTN (n=112)	0.16	0.32	0.21	0.23	0.14
<u>Otological History partialled for age and:</u>					
None (n=115)	0.29	0.29	-0.01	0.32	0.20
Anxiety (n=114)	0.25	0.21	-0.07	0.26	0.16
PSRTN (n=113)	0.26	0.26	-0.02	0.29	0.17
Anxiety & PSRTN (n=112)	0.23	0.20	-0.07	0.25	0.15

As expected from past literature, anxiety was positively correlated with all sub-scales of self-rated disability/handicap. The finding that some of these correlations remained significant (although they were diminished) when performance on speech-in-noise was partialled, indicates that anxiety acts on self-ratings somewhat independently of performance. It is of interest that all correlations between anxiety and self-report were reduced by partialling PSRTNs, except that for speech-in-quiet. This suggests that unreliability is probably not the explanation for the generally low correlations between speech-in-quiet and other variables.

The significant correlations between reported otological history and all self-rating scales (except for speech-in-quiet) were also anticipated. These correlations were diminished, and in the case of auditory handicap became non-significant, when anxiety was partialled, and when PSRTN was partialled. Partialling anxiety tended to have a slightly greater effect than did partialling PSRTN. Partialling both anxiety and PSRTN together did not substantially diminish the correlations further.

6.2.4.3.2 Discussion: Demographic and Personality-Related Correlates of Self-Rated Disability and Handicap

Unlike past work, this study found no relationship between self-rated disability/handicap and either age (Lutman et al, 1987; Merluzzi & Hinchcliffe, 1973), nor socio-economic status (Lutman et al, 1987) - defined here by educational level. However, the subjects here were of a restricted age (≤ 55 years) and had less variation in pure tone sensitivity than those in the above studies.

Both of these factors probably explain the null relationships in the present study.

Anxiety level correlated significantly with all self-rated disability scales, thus highlighting the subjectivity of self-report questionnaires, as discussed by, for example, Stephens (1987). Partialling of the PSRTN gave an indication of whether anxiety level and performance ability were independent in their relationship with self-rated disability/handicap. The finding that correlations diminished, but still remained significant after partialling shows that to an extent they were independent, but not completely so. This might suggest that: (i) anxiety level directly influences self-rated disability/handicap, and (ii) through its effect upon performance, anxiety level indirectly influences self-rated disability/handicap. Such effects must be considered when interpreting self-rating scales. Regarding the indirect influence of anxiety, from these results it is not possible to show whether anxiety has caused a deterioration in performance and hence an increase in self-ratings, or whether, as a result of poor performance, individuals have become more anxious and hence rate their disability/handicap higher. A distinction between these two causal influences would be useful for the counselling of patients.

As anticipated, otological history correlated well with self-rated disability and handicap; however, these correlations were diminished when anxiety was partialled out. This can be understood by bearing in mind that the otological history of subjects was learned from self-report; it was not practical to validate these reports from medical notes. Hence, it seems that recall of a history of ear disorder (and possibly of other conditions

too) is positively associated with anxiety, irrespective of actual effects of the conditions. As above, it is not possible to say what is cause and what is effect. The diminution of the correlations after partialling PSRTN suggests that a history of otological disorder is genuinely associated with performance ability, and hence with self-rated disability. This might occur through mild central disorder or minor conductive pathology. Correlations amongst all the disability sub-scales did, however, remain significant after partialling both anxiety and PSRTN, suggesting that otological history also acts directly on self-rated disability. These findings are in contrast to those of Swan & Gatehouse (1988) who showed that hearing-impaired individuals consulting a clinic did not have a stronger history of active ear disease, family history of ear disease or tinnitus than hearing-impaired individuals (with similar loss) not consulting a clinic. This discrepancy may have arisen through the effect being swamped by other factors in their hearing-impaired population.

In summary, self-rated disability questionnaires were related to both personality variables and history of ear disorder. These factors should be borne in mind when interpreting such questionnaires.

6.2.5 General Summary and Conclusions

The correlational aspects of the data have demonstrated the following four main points.

First, within this normally-hearing population there are small, but significant correlations between self-rated

auditory disability/handicap and performance, psychoacoustic, cognitive and personality-related variables. Findings of this nature have not previously been reported for an audiometrically normal population, but have been among the hearing impaired. The existence of these correlations implies a continuum, rather than a cut-off point, for the onset of auditory disability/handicap due to minor psychoacoustic and/or cognitive impairment. This therefore implies that the presently used criterion of 'normality' (thresholds of ≤ 20 dBHL) is arbitrary. However, in clinical practice self-reports cannot always be relied upon as being accurate, and hence a working definition of normality is required. The presently used criterion of 20dBHL is under debate as being too high. Figures around 15dBHL have been forwarded as being more appropriate. This study did not directly tackle the issue of an appropriate cut-off point for normality.

Second, pure-tone sensitivity was a very poor predictor of self-rated disability/handicap among these normally-hearing individuals, even though minor auditory dysfunction clearly existed (see the correlations of self-rated disability with the PSRTs). In order to validate clinical reports of auditory disability/handicap, a test of speech discrimination in noise, rather than pure tone sensitivity, should therefore be used.

Third, self-rated handicap generally correlated less well with psychoacoustic and cognitive variables than did self-rated disability. This implies that the handicap experienced by an individual is influenced more by social and personality-related factors than is the disability they experience. In contrast, when dealing with normal to

mildly-impaired individuals (OAD patients, for example) experienced handicap, rather than disability appears to be the factor that should play the major role in determining the degree of investigation and counselling given. For evidence see section 3.5.2.1.1, which showed that OAD status correlates more highly with self-rated handicap than self-rated disability. Thus, the possible influences of personality should always be borne in mind when interpreting hearing questionnaires.

6.3 RELATIONS BETWEEN PERFORMANCE ABILITY AND PSYCHOACOUSTIC, COGNITIVE AND PERSONALITY-RELATED VARIABLES

6.3.1 Literature Review

Difficulty hearing speech, particularly speech-in-noise, is the main complaint of hearing-impaired individuals. The cause of this disability can arise from a variety of sources: psychoacoustic (e.g poor frequency resolution or temporal resolution), cognitive (e.g a central auditory processing deficit) or personality-related factors (e.g anxiety). An understanding of the relationships of psychoacoustic variables to speech processing ability gives information about the level and forms of difficulty that different types of hearing loss will cause. Cognitive correlates of speech comprehension are of particular interest when dealing with learning-disabled children and with the elderly. Personality-related correlates are of general interest when counselling and advising hearing-impaired individuals.

6.3.1.1 Studies of Hearing-Impaired Listeners

Relations between psychoacoustic abilities and speech-in-noise comprehension have mainly been investigated in hearing-impaired populations. For example, Smoorenburg (1986) measured speech-reception thresholds in 200 individuals exposed to high levels of noise, with hearing levels ranging from normal to the highest measurable loss at 4kHz. He found that SRTs for speech-in-quiet correlated best with low-frequency pure tone thresholds, while speech-in-noise SRTs correlated with high-frequency thresholds. A similar finding was also reported by Parving et al (1986). In their normal to mildly impaired population, 2kHz thresholds correlated best with speech-in-quiet performance and 3kHz thresholds with speech-in-noise performance. Tyler & Smith (1983), on the other hand, using 30 individuals of mixed hearing ability, did not find clear differences when comparing correlations of high- and low-frequency pure tone averages with speech-in-noise ability (no measure of speech-in-quiet ability was made in that study). Lutman & Clark (1986) found that threshold at 2kHz was the best sensitivity correlate of speech-in-noise for a group of listeners with mild to moderate sensorineural loss. Multiple regression showed that adding additional frequencies did not improve the correlation. This is in contrast to Haggard et al's (1986) report that, for a population with a similar range of hearing-impairments, predictability was increased from including additional frequencies in the regression.

It is well documented that in hearing-impaired listeners, speech-in-noise intelligibility is closely related to frequency resolution, as frequency resolution deteriorates so does performance (Festen & Plomp, 1983; Dreschler & Plomp, 1980). Lutman and Clark (1986)

however, found that when age and sensitivity were partialled the relationship between frequency resolution and speech-in-noise was removed.

Temporal resolution has also been found to correlate with speech-in-noise comprehension (e.g Tyler et al, 1982(b); Moore, 1985). Tyler et al found this relationship to remain, even after partialling the effects of pure tone sensitivity. The initial analyses of Lutman & Clark (1986) found temporal resolution to be a major predictor of speech-in-noise ability, however, they point out that this relationship was based on the data of two subjects (out of 23) with the poorest temporal resolution; when these values were removed from the analyses, temporal resolution no longer entered the regression equation predicting speech-in-noise ability. They suggest that Tyler et al and Moore's correlations with temporal resolution are also inflated by a few extreme values.

Festen & Plomp (1983) carried out a study of relations between many psychoacoustic functions among the hearing impaired. They tested 22 sensorineurally hearing-impaired individuals on 18 psychoacoustic abilities and on two speech tests. Factor analysis showed the presence of two distinct clusters of tests - those related to frequency resolution and those related to audiometric threshold. Within each cluster variables were highly correlated, but between clusters variables were not. Comprehension of speech-in-noise was in the former group with other variables associated with frequency selectivity (low-frequency edge of the PTC, and bandwidth in simultaneous masking). Speech-in-quiet comprehension fell in the latter cluster, along with variables such as slopes of forward and backward masking. Temporal resolution ability was found to be only weakly related to frequency

resolution and was independent of hearing loss.

In summary, studies employing individuals with a range of hearing impairments tend to show fairly high correlations between speech intelligibility in noise and pure tone sensitivity, frequency resolution and temporal resolution. However, these studies also show the need to check that correlations are not mediated by just a few extreme values.

6.3.1.2 Studies of Normally-Hearing Listeners

Studies of correlations among auditory functions in normally hearing listeners are less common, one reason being that correlational analyses require considerable variation in the parameters being correlated. By the very nature of a normally-hearing population this variation is small. The earliest accessible study on relations between auditory functions was by Elliot et al (1966). They measured a variety of psychoacoustic and performance abilities, and gained socio-demographic data from a large sample of normally-hearing young adults. They found frequency, intensity and temporal discrimination measures to be largely independent of each other; socio-demographic data were also independent of auditory measures. However, educational aptitude and linguistic tests (vocabulary and word fluency) were positively correlated with speech discrimination. The most thorough recent study of correlations among auditory functions in normally hearing individuals was carried out by Festen & Plomp (1981). They measured 12 different psychoacoustic abilities, including frequency and temporal resolution,

using simultaneous and non-simultaneous masking. Factor analysis showed no structure within the data. They found a reciprocal relationship between frequency resolution and temporal resolution (also shown by Shailer & Moore, 1983), but the remaining auditory functions were independent of each other. The data of Haggard et al (1988) have also shown there to be little relationship between psychoacoustic functions in normally-hearing listeners. Data from the National Study of Hearing - NSH (a large cross-sectional epidemiological study) showed low, but significant, age-partialled correlations between pure-tone sensitivity and performance on a speech-in-noise task. The correlations increased as the audiometric cut-off point was raised from <20dBHL, through <25dBHL, to <30dBHL. Reported in the same publication are results from another large set of data showing age-partialled correlations between speech-in-noise and pure tone sensitivity; these were non-significant until the audiometric cut-point was raised to <30dBHL. Regarding the relationship of other psychoacoustic abilities to speech comprehension, Haggard et al's data showed no relationship between speech-in-noise ability and frequency or temporal resolution for individuals with thresholds <20dbHL.

6.3.1.3 Central/Cognitive, Personality-Related and Demographic Studies

Era et al (1986) studied a variety of cognitive functions and speech comprehension ability among men of different ages (31-35, 51-55, 71-75). They found that speech comprehension ability worsened with age, but that this

could not be fully explained in terms of pure tone sensitivity. A similar finding has also been reported by Dubno et al (1984) and Davis (1983a). In all age groups Era et al found poor speech understanding to be related to slow perceptuo-motor speed, even after the effects of education had been partialled. Cognitive variables (verbal fluency, general arithmetic, digit span and visuospatial ability) were positively correlated with speech understanding in each age group. Surprisingly, however, arithmetic and digit span ability appeared to be correlated more strongly with speech understanding than was verbal fluency. On the other hand, Granick et al (1976) and Thomas et al (1983) found verbal cognitive performance to be more closely associated with hearing loss than non-verbal cognitive tests. Cunningham et al (1987) report evidence that chronic pulmonary disease can lead to central auditory dysfunction, and postulate that this can lead to poor speech comprehension. They suggest that smoking, a diet high in animal fat and cholesterol and sedentary life-styles could have similar effects. However, Era et al found no association between smoking, drinking, physical activity and speech understanding in any age group.

Weinstein & Ventry (1982) report negative correlations between scales of social interaction on a questionnaire and performance on a speech discrimination task, while Era et al (1986), Norris & Cunningham (1981) and Thomas et al (1983) did not find any such relationships between psychological well-being and speech discrimination. Era et al found that socioeconomic status was positively correlated with speech understanding in all age groups, as was educational level in all but the youngest age group.

In the following paragraphs I summarise the relationships expected within the whole set of data collected for this project (n=115) between performance on three speech discrimination tasks and psychoacoustic, cognitive and personality-related variables.

6.3.2 Expected Relationships

6.3.2.1 Psychoacoustic Correlates

Table 6.5 shows the relationships predicted from past literature, that theoretically might exist between psychoacoustic measures and performance measures used in this study.

Past work has shown much stronger relationships between psychoacoustic function and speech discrimination in hearing-impaired populations than in normally-hearing populations. All correlations in this normally-hearing population might, therefore, be relatively weak. However, from past literature it is predicted that measures of speech-in-noise ability will correlate relatively strongly with frequency and possibly temporal resolution, and with all masked thresholds, but better with the mid- than the low-frequency masked threshold. In addition, it is predicted that the PSRTs from the PFFIN test will correlate moderately with the BMLD. The speech-in-quiet measure, on the other hand, should correlate moderately with pure tone sensitivity and temporal resolution, but not with any other measure.

Table 6.5
Summary of expected relationships between
psychoacoustic variables and performance measures

	PSRTN/PSRTB ¹	ASRTN ²	FAAF ³ (band-stop)
Pure tone sensitivity	+	+	++
*Low-freq.	++	++	+
*High-freq.	+++	+++	
Frequency resolution	+++	+++	
BMLD	++		
Temporal resolution	+++	+++	++

¹Measure of speech-in-noise from the PFFIN test

²Measure of speech-in-noise from the lipreading test

³Measure of speech-in-quiet

*=masked threshold. + represents small positive correlation, ++ represents moderate positive correlation, and +++ represents a strong positive correlation.

6.3.2.2 Central/Cognitive Correlates

Discrimination of speech-in-noise requires both peripheral and central auditory ability; speech-in-quiet processing also requires these abilities, but to a lesser extent. Therefore it is predicted that the dichotic scores will correlate with performance on all speech tests, but more strongly with the speech-in-noise tests, than with the test for speech-in-quiet. Performance on a sentence-based test can benefit from the use of top-down linguistic processing, while a closed-set forced-choice

test cannot. Therefore it is predicted that the speech-in-noise sentence tests will correlate negatively with reaction time on the sentence monitoring test, while the closed-set FAAF test scores will not correlate with sentence monitoring.

6.3.2.3 Demographic and Personality-Related Correlates

It is predicted that age will correlate negatively with performance on all tests due to the gradual deterioration of peripheral and central auditory functions that occurs over time. Both anxiety and depression can influence arousal level, and hence performance. It is therefore predicted that they will correlate negatively with performance on all tests, due to over-arousal and under-arousal respectively. Childhood and adult otological disorder might correlate negatively with performance due to their influencing linguistic ability and/or hearing sensitivity.

6.3.3 Method

Data from all 115 subjects in stage II of the study were used for all analyses excepting those with the FAAF test score, which are based on 105 subjects (FAAF data were not acquired for some patient-controls, and are missing for three OADs). Pearson correlation coefficients were computed between performance measures, and psychoacoustic, cognitive and personality-related variables. All correlations presented are partialled for age, sex and educational level. Correlations with

psychoacoustic measures (excluding, of course, pure tone averages) are also partialled for average pure tone sensitivity. Once again, all analyses were carried out twice, once including, and once excluding extreme values as determined by the distribution of each variable.

6.3.4 Results and Discussion

6.3.4.1.1 Results: Psychoacoustic Correlates of Performance Measures

Table 6.6 shows correlations between psychoacoustic functions and four performance measures partialled for age, sex, educational level and pure tone sensitivity¹. Partialling of pure tone sensitivity however, made little difference to the correlations. Figures in brackets are additionally partialled for frequency resolution at 2kHz. As in table 6.2 above, the low-frequency masked threshold replicates were averaged prior to analysis. The two mid-frequency masked threshold conditions were not averaged, since the correlations with the raw variables differed significantly. On re-analysis with extreme values excluded, correlations between the FAAF score and psychoacoustic variables differed, while those with the PSRTN, PSRTB and ASRTN did not. The re-analysed data are presented here.

¹Those correlations between performance measures and average audiogram are only partialled for age, sex, and educational level.

Table 6.6

Correlations between performance measures and psychoacoustic variables after partialling for age, sex, educational level and pure tone sensitivity. Bracketed figures are additionally partialled for frequency resolution at 2kHz. For n=110, $p < 0.05$ if $|r| > 0.19$, for n=98, $p < 0.05$ if $|r| > 0.195$

	PSRTN (n=110)	PSRTB (n=110)	ASRTN (n=110)	Band-stop FAAF score (n=98)
AVAUDIO ¹	0.01	-0.02	-0.18	-0.07
AVHIGH ²	-0.06	-0.08	-0.18	-0.12
AVLOW ³	0.10	-0.03	-0.13	-0.03
Freq. Res.	0.05	-0.01	0.12	-0.17
*Mid-freq. notch	0.18	0.12	0.24	-0.08
*Mid-freq. wide-band	0.34	0.33	0.32	0.20
*Low-freq.	0.50 (0.50)	0.40 (0.40)	0.40 (0.40)	0.29 (0.28)
BMLD	0.30	0.09	0.11	0.10
Gap detection	-0.30	-0.24	-0.38	-0.14

¹Binaural average of all frequencies measured,

²Binaural average of 3, 4, 6 kHz, ³Binaural average of 0.125, 0.25 & 0.50 kHz. *=masked threshold

No pure-tone average correlated significantly with any performance measure, nor did the computed measure of frequency resolution.

Masked thresholds in the low-frequency and mid-frequency low-pass conditions correlated well with all speech-in-noise measures. Contrary to predictions based on past literature, however, it was the low-, rather than mid-frequency thresholds that were best correlated. The notch condition of the mid-frequency masked threshold only

correlated significantly with the audiovisual ASRTN, although the difference in correlations for the notch and low-pass conditions were only significant for the performance SRTB (Fisher $Z = 2.37$, $p < 0.025$). Masked thresholds correlated less well with the FAAF scores, although two of the three correlations were significant.

As predicted, BMLD correlated significantly more strongly with the PSRTN than with the ASRTN (Fisher $Z = 2.15$, $p < 0.05$). Contrary to expectation, the BMLD did not correlate with the PSRTB.

Gap detection correlated well with each speech-in-noise measure, as expected, but did not with the FAAF score.

Factor analysis of the 6 different psychoacoustic variables (average audiogram, mid-frequency masked threshold both notch and wide-band conditions, average of low-frequency masked threshold (1) and (2), BMLD and gap detection threshold) using the principle components method with varimax rotation, showed the presence of two distinct clusters of variables (Table 6.7)

Factor 1 included masked thresholds and gap detection. These can all be interpreted as reflecting random noise within the nervous system. Factor 2 incorporated a mixture of psychoacoustic variables, from a peripheral measure (pure tone sensitivity) to one with a strong central loading (BMLD). This factor possibly reflects processing of low- to mid-frequency information.

Table 6.7
 Factor analysis using varimax rotation of
 the 6 different psychoacoustic variables
 Factor loadings <0.5 are excluded

Factor 1		Factor 2	
Variable	Loading	Variable	Loading
*Mid-freq. wide-band	0.824	BMLD	-0.881
Gap detection threshold	-0.758	*Low-freq. ¹	0.630
*Mid-freq. notch	0.713	Average audiogram	-0.509
*Low-freq. ¹	0.630		

% variance explained: 27%

11%

*=masked threshold. ¹=average of low-frequency masked threshold replicates.

6.3.4.1.2 Discussion: Psychoacoustic Correlates of Performance Measures

The finding that none of the pure tone averages related significantly to actual performance, even to speech-in-quiet, is not surprising in view of past work on groups with a small variance in pure tone thresholds as found in a normally hearing population (Haggard et al, 1988). Similarly Smoorenburg (1986) found little relationship between SRTs and pure-tone sensitivity in subjects with pure tone averages of <10dBHL (average of 2 and 4kHz),

but in subjects with pure tone averages above this, the SRT obviously rose. Some individuals in this study have thresholds above 10dBHL, but there are comparatively few of them (n=29). There is a slight trend for high-frequency sensitivity to correlate better with all performance tests than low-frequency sensitivity. From the work of Aniansson this trend might have been expected to be stronger. The null findings here suggest that in cases of marginal pathology, pure tone sensitivity is not a useful predictor of speech comprehension.

The relationship between masked thresholds and speech-in-noise ability is in accordance with much psychoacoustic literature (Moore, 1985). This is further supported by the finding that masked thresholds correlated better with the measures of speech-in-noise than with the measure of speech-in-quiet (FAAF). In section 3.6.1.2(b) it was pointed out that masked thresholds are a combined measure of two factors: frequency resolution and a general processing efficiency that can be interpreted as random noise within the auditory system. Again, as pointed out in section 3.5.1.2(b), the latter would seem to be the more important factor, as suggested by the following observations. First, the present measure of frequency resolution per se was not correlated with any performance measure. This implies that either the measure of frequency resolution, or frequency resolution itself, is not closely associated with speech-in-noise comprehension. Only very low correlations between frequency resolution and speech-in-noise were also found in stage I of this study, using a different measure of frequency resolution. It seems, therefore, that the null finding is due to the absence of any important relationship. Second, when frequency resolution ability

(as calculated from the mid-frequency masked thresholds) was partialled, correlations between the low-frequency masked thresholds and speech-in-noise performance remained almost unchanged. If frequency resolution were playing a large role this partialling would have diminished them. It should be noted, however, that frequency resolution was measured at 2kHz, while the low-frequency masked thresholds were tested at 500Hz. The higher correlations between performance and the wide-band condition, as compared to the notch condition, might also reflect the relative loading of the correlations on internal noise (predominantly measured by the wide-band condition) rather than frequency resolution *per se* (predominantly measured by the notch condition).

Surprisingly, low-frequency masked thresholds correlated significantly better with the PSRTN, PSRTB and FAAF than did mid-frequency masked thresholds. In the case of the PSRTN, the white noise might have masked all high-frequency speech information, forcing subjects to rely on low-frequency energy. If this were the only explanation, however, a similar result would have been expected with the ASRTN, but this was not found. In the case of the FAAF test, the higher correlation of the low-frequency masked threshold might have been the result of filtering the stimuli between 0.6 and 4.8kHz, reflecting low-frequency sensitivity.

The absence of correlations between frequency resolution *per se* and performance measures is in accordance with other studies of normally-hearing individuals (Haggard et al, 1988; Festen & Plomp, 1981; Lutman & Clark, 1986). The latter report that correlations of speech-in-noise performance with frequency resolution are removed once the effects of pure tone sensitivity and age are

partialled. It must be concluded that frequency resolution ability is so strongly associated with age and sensitivity that it is not possible to separate out their individual effects.

BMLDs were significantly more closely associated with the PSRTN than with the ASRTN, probably reflecting the binaural nature of the PFFIN test, and strongly suggests that pseudo-free-field recording (Gatehouse, 1988) reproduces some free-field processing conditions. It is surprising, however, that this result was not replicated in the correlation with the PSRTB, although this finding is consistent with generally weaker relationships with the PSRTB seen throughout the data. Possibly the less homogeneous envelope of the babble masker has attention effects that override the binaural effects common to the PSRTN and BMLD.

As expected, gap detection ability was strongly associated with all tests of speech-in-noise, reflecting the need for temporal resolution for speech-in-noise processing (see section 3.2.1(b)). Temporal resolution would appear to be less important for processing of speech-in-quiet, as evidenced by the non-significant correlation between FAAF score and gap threshold.

The white noise masked SRTs (PSRTN and ASRTN) correlated better with all psychoacoustic variables than the babble-masked SRT (PSRTB). There are two fundamental differences between these two maskers: first, white noise has a flat spectrum, while babble has a speech-shaped spectrum; second, white noise has a homogeneous envelope, while babble contains conjoint spectro-temporal variations. The spectral differences lead to different masking effects: white noise acts in a similar way to a

low-pass filter, leaving only some mid- to low-frequency speech information available; babble masks the speech signal uniformly at all frequencies (see figure 3.6). Low- and mid-frequency stimuli (0.5 and 2kHz) were used for the psychoacoustic tests. Any variation in psychoacoustic abilities would, therefore be reflected more by the PSRTN than the PSRTB. This would explain the higher correlations of peripheral psychoacoustic processes with the PSRTN than with the PSRTB. On the other hand, the envelope difference between the two maskers might be influencing the correlation pattern. The modulated speech babble might influence central, as well as peripheral factors, while the homogeneous white noise might have mainly peripheral effects. Psychoacoustic variables mainly reflect peripheral processes, which would explain why they relate more closely to white noise than to modulated babble. It is impossible to be certain about which of these explanations is correct; however, the former suggestion seems more likely. In order to confirm this, an unmodulated speech-shaped masker would have to be used.

The PSRTN correlated more strongly with the psychoacoustic variables did the ASRTN. The fundamental difference between these two measures is the recording conditions of the test. The pseudo-free-field recording appears to have given greater sensitivity, and hence stronger relationships to psychoacoustic variables, than did conventional recording.

The relatively low correlations of the FAAF test with all variables shows that measures of speech-in-quiet, even particularly sensitive ones (Foster & Haggard, 1979), are not sensitive to minor auditory dysfunction in a 'normally-hearing' population.

In contrast to the findings of Festen & Plomp (1983), factor analysis of psychoacoustic variables here revealed relations between auditory functions in this normally-hearing population. Although the combined factors did not explain much of the total variance (38%). Factor 1 included variables mainly associated with random noise within the auditory system. Factor 2 seemed to include a mixture of variables, that might be associated with the processing of low-frequency information. Subjects in Festen & Plomp's study had thresholds of ≤ 15 dBHL. In this study the criterion for inclusion was slightly less strict (≤ 20 dB). The additional variance in abilities found in subjects with thresholds between 15 and 20 dBHL might explain the positive findings here.

In summary, pure tone sensitivity did not reflect performance in noise in this normally-hearing population. However, both masked thresholds and gap detection ability did. In a population with 'normal hearing', therefore, tests of subtle psychoacoustic function could be used to understand minor performance deficits, where pure tone sensitivity cannot. A white noise masker (i.e flat-spectrum and with a homogeneous envelope) would appear to be more sensitive to minor psychoacoustic dysfunction than a speech-babble modulated masker. The filtered FAAF score did not appear to be sensitive to minor dysfunction in a 'normally-hearing' population. Nevertheless, associations among psychoacoustic abilities, that to date have only been seen in samples with a range of conventional hearing impairments have been clearly demonstrated in this normally-hearing population as well.

6.3.4.2.1 Results: Central/Cognitive Correlates of Performance Measures

Table 6.8 shows correlations between cognitive variables and performance tests that are partialled for age, sex and educational level. Correlations with mean reaction time on the linguistic test are excluded because no correlation reached significance. Once again, re-analysis of the data excluding extreme values altered correlations between score on the FAAF test and other central/cognitive variables. These re-analysed correlations are presented.

The PSRTN was significantly correlated with performance in all dichotic listening conditions, as was the FAAF score on two of the three conditions, and the ASRTN on one of the three. The PSRTB did not correlate with any dichotic condition. The various conditions of the dichotic test did not display markedly different patterns of correlation.

Table 6.8

Correlations between performance measures and cognitive variables after partialling age, sex and educational level. For n=110, $p < 0.05$ if $|r| > 0.19$, for n=98, $p < 0.05$ if $|r| > 0.195$

	PSRTN (n=110)	PSRTB (n=110)	ASRTN (n=110)	Band-stop FAAF score (n=98)
*Focus	0.29	0.10	0.11	0.21
*Divide	0.26	0.09	0.21	0.19
*All	0.32	0.11	0.16	0.23

* = from dichotic listening test

6.3.4.2.2 Discussion: Central/Cognitive Correlates of Performance Measures

Reaction-time on the linguistic test did not correlate with any sentence-based performance measure. This was probably due to a combination of the linguistic test being insufficiently sensitive to minor differences in ability within a 'linguistically normal' population, and performance on speech tests not being related to reaction-time tasks, which are relatively artificial. However, even considering this, correlations might still have been expected in view of Elliot et al's (1966) finding of correlations between performance on a speech-in-noise test and performance on linguistic tests, and Era et al's (1986) finding that perceptuo-motor speed is associated with speech understanding (in quiet and in

noise). However, the reaction-time variable here was confounded by the linguistic element of the test, this probably explains the null findings.

Regarding the dichotic variables, it was predicted that both conditions (combined and separate) would correlate more strongly with speech-in-noise than with speech-in-quiet because of the greater central loading on a taxing speech-in-noise task. In the case of the PSRTN this prediction was confirmed. However, in comparison to the PSRTB and ASRTN, the PSRTN and FAAF score correlated well with all dichotic conditions. This implies that the PSRTN and FAAF tests are relatively sensitive to cognitive function. The reasons why these tests should be more sensitive than the PSRTB and ASRTN is not entirely clear. However, it does seem that the test most sensitive to psychoacoustic function was also that which most reflected general cognitive function, and a more complete battery would be needed to dissociate the two levels of function.

6.3.4.3.1 Results: Demographic and Personality-Related Correlates of Performance Measures

Table 6.9 shows raw correlations of demographic variables with performance measures, once again extreme values on the performance measures are excluded. The figures in brackets are partialled for the effects of age and average audiogram.

Table 6.9
 Correlations between performance measures and demographic variables. Figures in brackets are partialled for pure tone sensitivity. For n=110, $p < 0.05$ if $|r| > 0.19$ for n=98, $p < 0.05$ if $|r| > 0.195$

	PSRTN (n=110)	PSRTB (n=110)	ASRTN (n=110)	Band-stop FAAF score (n=98)
Age	0.10 (0.11)	0.08 (0.09)	0.17 (0.21)	0.04 (0.07)
Education level	-0.07 (-0.06)	-0.06 (-0.05)	-0.08 (-0.03)	-0.25 (-0.22)

Age was not significantly correlated with performance in this sample. Educational level was only correlated with score on the FAAF test, in the direction that better educated individuals scored more highly. Once pure tone sensitivity was partialled, the correlation between age and ASRTN became just significant, while that between educational level and FAAF was diminished. The remaining correlations did not change.

Table 6.10 shows correlations of anxiety, depression and otological history with performance tests. All correlations are partialled for age, sex and education level. Figures in brackets are additionally partialled for the effects of hearing sensitivity. Once again, the results presented are those excluding extreme values.

All performance tests correlated with anxiety and depression in the expected direction. However, only in three out of eight instances were the correlations

significant, and then only marginally. The partialling of hearing sensitivity did not alter any of the correlations. Otological history also correlated with performance in the expected direction, but again correlations were either marginal or non-significant. Partialling of hearing sensitivity had no consistent effects.

Table 6.10

Correlations between performance measures and personality-related variables after partialling age, sex and educational level. Bracketed figures are additionally partialled for pure tone sensitivity.

For n=110, $p < 0.05$ if $|r| > 0.19$,
for n=98, $p < 0.05$ if $|r| > 0.195$

	PSRTN (n=110)	PSRTB (n=110)	ASRTN (n=110)	FAAF Score (n=98)
General anxiety	-0.20 (-0.20)	-0.11 (-0.11)	-0.23 (-0.22)	-0.01 (-0.01)
Depression rating	-0.19 (-0.19)	-0.10 (-0.10)	-0.18 (-0.17)	-0.20 (-0.20)
Otological history	-0.09 (-0.09)	-0.21 (-0.22)	-0.20 (-0.17)	0.05 (0.08)

6.3.4.3.2 Discussion: Demographic and Personality-Related Correlates of Performance Measures

Unlike other studies (Davis, 1983a; Era et al, 1986) this investigation found only one significant correlation between demographic variables and performance, after the

appropriate variables had been partialled, that between FAAF scores and educational level. The reason probably lies in the constraint placed upon age and hearing levels for inclusion in the study, and the possible artifactual selecting out of the lower socio-economic groups in the clinical referral process (section 3.5.1) An explanation for the finding that better-educated individuals performed better on the FAAF test might be that these individuals were able to adjust to the unusual speech signal more quickly than the less educated (and possibly, also, less intelligent) individuals.

Anxiety and depression were negatively associated with performance, as also shown by others (e.g Weinstein & Ventry 1982; Marcus-Bernstein, 1986). However, correlations here were only marginally significant (if at all). Studies showing significant effects of anxiety and depression on performance have generally used elderly individuals with hearing losses. Aging and hearing loss are both associated with increased depression (Moore & Whanger, 1983; Gilholme Herbst & Humphrey, 1980 respectively), and anxiety. It is not surprising that correlations here were of marginal significance, since all individuals had normal hearing, and few were known to be clinically depressed or clinically neurotic. The finding that correlations between anxiety/depression and performance were not diminished when hearing sensitivity was partialled, suggests that anxiety and depression were a psychological reaction to actual hearing loss.

Reported otological history was not associated with performance either. If reported history is taken as an indication of actual early middle-ear disorder this gives support to recent work (Silva et al, 1986) that effects of middle ear disease in childhood hearing disorder on

auditory performance are not long lasting. This is only partly consistent with the findings for the OAD-control group difference (section 3.5.2.3, table 3.9), in which otological history was not associated with performance on the PSRTN, but was for the PSRTB; the group difference was removed when the effect of otological history (higher among the OADs) was removed with ANCOVA.

In summary, demographic variables were not associated with performance in this population, although anxiety and depression were. Past otological disorder did not appear to have lasting auditory effects.

6.3.5 General Summary and Conclusions

Four main points have emerged from the correlational aspects of the data. First there were clear relationships between performance and auditory function in normally-hearing individuals. Past work has not found this (Festen & Plomp, 1983). The positive findings here are probably the result of using a highly sensitive performance test - the white-noise masked adaptive PFFIN test. Second, as other studies have shown, there was no relationship between pure tone sensitivity and performance in normally-hearing subjects. This suggests that more subtle tests of psychoacoustic function are required for investigation of poor auditory performance in individuals with normal hearing. Thirdly, correlations between cognitive variables and performance highlight the importance of non-sensory variables in speech perception. Finally, the marginal correlations of anxiety and depression with performance suggests that only in extreme cases do personality traits influence performance and/or vice versa.

CHAPTER 7

FINAL SUMMARY AND CONCLUSIONS

The initial aims of this thesis were (a) to learn the factors underlying OAD and (b) to devise a package of tests to enable ENT clinicians to diagnose and investigate OAD in patients presenting at their clinics. Both of these aims were reached, in addition the influence of personality on health-related behaviour was demonstrated, as were a number of relationships between self-rated disability/handicap, performance ability, psychoacoustic function and central/cognitive abilities.

In chapters 2 and 3 the factors underlying OAD status were investigated and elucidated. It can be concluded that OAD is a multifactorial syndrome, in which psychoacoustic, cognitive/central and personality-related factors all play a role. Both stages I and II produced this conclusion. In addition, the stage II modelling suggests that the roles of variables explaining OAD status are independent between domains, yet are not independent within each domain. In the majority of cases, factors from two or more of these domains appears to be necessary before individuals become OAD patients. This strongly supports the need for multi-disciplinary investigations when health-related behaviour is being considered. The finding that OAD patients as a group have a measurable performance deficit, as well as various forms of minor auditory dysfunction, implies that clinical tests used at present are not sufficiently sensitive to measure subtle dysfunction, and that therefore, many individuals presenting with specific complaints (such as difficulty hearing speech-in-noise) do warrant further, more sensitive, investigations. However, it must be emphasised that loss of frequency

resolution is not a necessary prerequisite for OAD status, and may not even be a sufficient one.

Anxiety level differentiated two groups of individuals who had sought medical attention from those who had not (OAD and patient-controls from normals, i.e. random-controls). The patient controls were, however, similar to the random controls in terms of psychoacoustic and cognitive function. This shows the influence of personality upon health behaviour, and highlights the importance of considering such factors during medical investigation and management. This conclusion was further emphasised in chapter 6, where self-rated auditory disability and handicap were found to correlate with anxiety level.

Finally, the demonstration of relationships between some psychoacoustic abilities and performance, but not between pure tone sensitivity and performance suggests that pure tone sensitivity is not a good indicator of relatively slight auditory impairment, but that other measures, such as actual performance, masked thresholds and gap detection thresholds, can be.

APPENDICES

APPENDIX 2.1 - FINAL FORM OF OAD INTERVIEW

SECTION A - Biographical Information

Name _____ Gender M/F Date _____

1.1 What is your date of birth? D _____ M _____ Y _____

1.2 Was English your first language Y N

2.1 (a) Are you aware of having had any particular difficulties learning to read or write as a child? Y N

(b) If yes, what were they?

3.1 (a) At what age did you finish full-time education?

(b) What is your highest educational qualification?

3.2 (a) What job do you do now or when last employed?

(b) How many people are/were you responsible for?

4.1 (a) Have you ever worked in a workshop with fumes or chemicals with poor ventilation Y N

(b) If so, for how long?

(c) What job were you doing?

SECTION B - Health Information

1.1 (a) Are you generally a healthy person? Y N

(b) If not, what forms of ill-health do you have?

1.2 (a) Do you tend to worry about your health? Y N

(b) If so, about what in particular?

1.3 If family doctors offered a regular check-up service would you be inclined to take advantage of them? Y N

1.4 (a) Have you had any major illnesses occurring within the last 2 years? Y N

(b) If so, what?

1.5 (a) Do you have any respiratory or heart problems?
Y N

(b) If so, what?

Have you ever suffered from:

2.1 (a) Fainting/blackouts regularly? Y N

(b) Is so, when?

(c) What happened?

2.2 (a) Giddiness or loss of balance? Y N

(b) If so, when?

(c) What happened

2.3 (a) Fits? Y N

(b) If so, when?

(c) What type?

2.4 (a) Concussion?

(b) If so, when?

(c) Were you unconscious? Y N

(d) Was your skull fractured? Y N

(e) Did it have any temporary or permanent
effects on your hearing? Y N

6.6	Do you get flustered if you have to act quickly?	Y		N
6.7	Do things easily get on your nerves?	Y		N
6.8	Is it often hard for you to make up your mind?	Y		N
6.9	Do you often have difficulty falling or staying asleep?	Y		N
7.1	Do you drink more alcohol when you are under stress	Y		N
7.2	Do you smoke more when under stress	Y	N	NA
8.1	Do you take regular exercise to keep fit?	Y		N

4.1 (a) What did the doctor say when you raised the problem?

(b) How did you get referred to the hospital?

5.1 (a) Had you ever had a hearing test before going to the doctor? Y N

(b) If so, what was the result?

6.1 (a) Does your hearing tend to vary from day to day? Y N

(b) If so, is there anything that causes it to vary? Y N

(c) What?

(d) How is it today as compared to usual?

6.2 (a) Do you feel you can hear equally well with both ears? Y N

(b) If not, which is your better ear? L R

7.1 (a) Does any member of your family have hearing problems? Y N

(b) if so:

Relationship	Age of onset	Cause
--------------	--------------	-------

8.1 By comparison with others are you particularly intolerant to loud noises? Y N

9.1 (a) Do you find the mood you are in affects your hearing? Y N

(b) How?

10.1 (a) Does your mood then get affected by your hearing problems? Y N

(b) How?

11.1 (a) Has the problem had any effect on your work? Y N

(b) If so, what?

11.2 (a) Has the problem had any effect on your social
life? Y N

(b) If so, what?

12.1 (a) Have other commented about your hearing?
Y N

(b) If so, how do you feel about such comments?

13.1 Do you avoid unfamiliar people or places? Y N

13.2 Do you enjoy meeting new people? Y N

13.3 At social occasions do you prefer someone
else to take the lead? Y N

13.4 Would you describe yourself as a confident
person? Y N

13.5 All in all, are you happy with yourself
and your life? Y N

APPENDIX 3.1 - INFORMATION SENT TO TRENT ENT CONSULTANTS
OAD - OBSCURE AUDITORY DYSFUNCTION

Background

We define 'obscure auditory dysfunction' (OAD) as "discrimination loss" in the under-55s accompanying an audiogram within normal limits and in the absence of neural or middle-ear signs. Among referrals for hearing loss, people fitting the above description are by no means uncommon - about 10% in one adult clinical sample recently analysed. Here "normal" has traditionally not been defined with great precision, but might comprise hearing threshold levels of not greater than 20 dB at any frequency up to 2 KHz but perhaps allowing a slightly greater loss at 4, 6 and 8 KHz.

OAD patients are often not investigated further on the grounds that nothing can currently be done to help them. This position has in turn led to a virtually total lack of research on the problem. The Institute of Hearing Research is now doing further investigations on patients in this OAD category for four reasons: (1) Several investigations have now suggested that the general "threshold" or "onset" of auditory disability lies somewhat below 20 dB HL; (2) new tests are available that might allow more to be said about the OAD problem, (including the possibility of delineating sub-groups that would in the future merit further investigation); (3) there is a need at very least for somewhat more definitive and standardised counselling than can at present be given, and which would need to be based upon a firmer understanding; (4) new noise-stripping techniques for speech enhancement are likely to become available in the next few years which might give this patient-group some relief from their feelings of effort and difficulty (although it would be some years before these could be provided as a wearable aid.)

New Clinic and the associated service-development project

Following the approval of an outline proposal by the Trent Regional ENT Advisory Committee, the Institute of Hearing Research proposes to start a regional clinic for investigating OAD patients in mid March 1987. A trial stage of the clinic is nearing completion; the test battery and protocols are currently being refined on the basis of comparisons with control subjects.

(a) Objectives

- (1) The first objective is to understand the problem better i.e. to find out what particular combination of clinical features characterises this clinical group

(see "Hypotheses" below). This knowledge is being sought because it should yield eventual benefits to patients i.e. better guidelines for diagnostic decisions and simple robust tests that can be used in ENT practice. The characterisation will also determine whether the variables leading this group to seek assistance are the same as those influencing the highly variable tendency to seek assistance in those with some degree of conventional hearing impairment.

- (2) The second objective is, via immediate counselling and the reports back to consultants, to assist the referred patients themselves. Evidence to date suggests that the counselling is already beneficial, but without the achievement of objective 1 and a more formal evaluation we cannot make strong claims for this.
- (3) Experience with a number of the patients is leading to the development of a clinical interview technique and a set of guiding principles for counselling. The third objective is to improve and standardise these techniques and eventually to make them available to otolaryngologists via publication, and so help patients throughout the country.
- (4) The fourth objective is to determine whether any form of advanced signal-processing hearing aid could be beneficial for such cases.

All these objectives converge upon the development of a set of recommended procedures to be "given away" via publication of results and recommendations for incorporation in district ENT diagnostic services. We do not think there would be a long term need for specialised clinics of this nature.

(b) Hypotheses about OAD

Several explanations for the OAD problem are examined in the interviewing and underlie the construction of the test battery:

- Type A
- A 1 Communication skills deficit
 - A 2 Linguistic processing deficit
 - A 3 Poor lipreading
- Type B
- B 4 Discrepancy between subjective and objective (dis)ability
 - B 5 More general personality characteristics, eg anxiety, introversion
 - B 6 Inappropriate central decision criteria in auditory perception

- Type C 7 Subclinical sensory loss which the audiogram does not reflect, e.g. disturbances of frequency and/or temporal resolution
- C 8 Deficit of brainstem mechanisms of auditory localisation
- C 9 Deficit of brainstem mechanisms of auditory attention

Various possibilities can be thought of as clustering into a few main types. Type A and B would be, in different senses of the term, psychological, but nonetheless real for that. Type C is pathophysiological. Findings to date suggest that in some but not all OAD patients, Type C factors can be found. Depending upon the strongest element in our findings, or possibly upon the composition of the presenting OAD group in terms of definable sub-groups, the counselling implications would differ greatly.

(c) Referral arrangements

Once the clinic is running, reports on individual patients will be sent back to referring consultants. Immediate counselling, including advice on hearing tactics to cope in background noise will be given where possible and appropriate. It will be necessary for the clinic staff to indicate to patients whether it is likely that you, the consultant, would wish to see them again after their visit to the IHR. We can either implement your general preference in this respect or, with your agreement, judge the issue ourselves in the light of the test results. The reply slip allows for you to express your preference.

All test procedures and guidelines for counselling will be checked in advance by Dr Ross Coles, Consultant Audiological Physician and Coordinator of Clinical Studies at the Institute. He will also be directly involved where any special problems of counselling or possible referral for further investigation arises in particular patients. Thus, if there were any recommendations for further management, beyond those implicit in the test findings incorporated in the report to you, they would come from Dr Coles. From experience to date, however, the need for this is minimal. The testing will be performed on a regular basis by Diana Field (audiological scientist) and Ms Gabrielle Saunders (research psychologist), under the general supervision of Dr Coles and Professor Haggard.

A supply of reminder cards for filing or pinning up in appropriate places, giving the referral destination and the criteria for referral, is available.

It may be advisable to be cautious concerning the wording used to patients when summing up the clinical interview and mentioning referral to the IHR clinic. Of course, at the present state of knowledge, no-one can give a very clear indication of the value to them of attending our

clinic in relation to the lay concept of 'cure'. The particular way in which you report that you can find "nothing wrong with them" could adversely affect take-up of appointments at the IHR clinic, and, hence, the chance of some immediate benefit to the particular patient and long-term benefit to the whole group of patients; cautious optimism about the value of attendance seems to be the best tone to adopt. Most of the patients seen so far have found that the advice on 'hearing tactics' is helpful and that the element of reassurance has been well worthwhile attending for.

We realise that the location of the clinic in Nottingham may involve travelling some distance for many patients; in this respect the Institute of Hearing Research will pay any travel expenses incurred (train/bus or mileage at the current rate)

Please tear off and return to :- Gabrielle Saunders, Institute of
Hearing
Research, University Park, Nottingham, NG7 2RD.
(Please tick boxes as appropriate)

I would be prepared to refer
patients with apparent
I would not discrimination loss but
"normal" audiograms to the
special IHR clinic in
Nottingham.

I should anticipate from present trends wishing to refer
about such patients per year.

I should prefer to receive reports:

- (a) briefly on all patients
- (b) only on those referred back to
me or onward elsewhere for,
in exceptional circumstances,
further investigation/management

I should prefer the patients to be

- (a) counselled as fully as possible
at the IHR clinic and referred
back only in the event of
definitive signs demanding
investigation/treatment.
- (b) referred back to me in all
instances for full management
on the basis of the report,
with only restricted reassurance
and general information given
to the patient at IHR.

CONSULTANT NAME _____

HOSPITAL(S) _____

APPENDIX 3.2 - A TYPICAL PATIENT REPORT

The following is an example of a report sent to the referring consultant about a patient.

Mr X.X. FRCS
Hospital
Town

Dear X.X.

Re: Mr PH, D.O.B.

Address

You referred Mr PH to our Special Investigative Clinic for further assessment of his hearing. On April 21st we tested him on our OAD test battery.

Mr PH complains of difficulty hearing speech in the presence of background noise. He first noticed the problem about two years ago, and sought medical attention soon afterwards, because he was worried that he might have a "brain tumour". He mentioned that he sometime gets a buzzing tinnitus in both ears, but that it is very faint and does not bother him. As an adult he once had an ear infection in his right ear that caused pain and inflammation. It was successfully treated with antibiotics.

We confirmed Mr PH to have pure tone thresholds well within normal limits (see enclosed). He has normal frequency resolution, temporal resolution and normal binaural masking level differences (BMLDs). These findings are reflected in his above average performance on our speech-in-noise test ('objective' PFFIN).

Mr PH does, however, considerably underestimate his hearing ability, as seen from a comparison of results from the 'subjective' and 'objective' conditions of the PFFIN test. In the 'subjective' condition, the listener sets a signal-to-noise ratio at which he/she feels just able to discriminate speech in the presence of noise. In the 'objective' condition, the signal-to-noise ratio is determined by the listener's actual performance. relative to non-OADs, Mr PH set a considerably less adverse signal-to-noise ratio in the 'subjective' condition than that determined by his actual performance.

Mr PH also performed below average on our test of lipreading ability. It is known that poor lipreaders are

at a disadvantage to good lipreaders when in conditions of an adverse signal-to-noise ratio. In addition Mr PH is a highly anxious man, whose job causes him considerable stress. (He had a peptic ulcer at the age of 26 and now worries about all aspects of his health). Jointly these findings are sufficient to explain why he sought attention for his hearing.

We explained our findings to Mr PH, reassuring him that he need not worry that his hearing was deteriorating and that he should try to have more confidence in his hearing ability. He seemed extremely relieved to learn this. We also gave him advice on hearing tactics and a copy of the IHR Hearing Tactics leaflet. He seemed grateful for our advice.

I hope this information is useful to you in your further management of this patient.

Your sincerely

Ms Gabrielle Saunders
(Research Student)

APPENDIX 3.3 - CASE REPORT OF A PATIENT REFERRED TO THE OAD CLINIC NOT FITTING THE OAD CRITERIA

Case report of patient J.O.

A 53 year old man was referred to the OAD special investigative clinic after having fully recovered from a mild stroke. The patient had presented at the referring hospital complaining that since his stroke sound had become distorted and slowed. After ENT examination had proved normal he was referred to the IHR clinic where he reported that voices sounded "flat" and "slowed down", and that music had become "unrecognisably different". He also mentioned that his hearing varied from day to day, but that, at best, sounds became louder but not clearer. The patient did not report any past or present ear disorder nor tinnitus.

The patient proved to have normal thresholds in his right ear at frequencies of 250Hz to 3kHz, and in his left ear at frequencies of 1, 2 & 3kHz. All other thresholds were raised above normal (see figure 1). Bone conduction showed these losses to be of primarily sensorineural nature.

The patient's raised pure tone thresholds, and the origin of his complaint (i.e post-stroke) excluded him from the OAD population. Nevertheless, he was given appropriate further clinical assessment, as follows.

Measurement of frequency resolution, temporal resolution and BMLDs was carried out, along with tympanometry, acoustic reflex testing, and conventional speech audiometry - in quiet and in noise. The OAD stage II interview and the NIR form were also completed.

Results showed the patient to have normal frequency resolution and normal temporal resolution in both ears, and normal BMLDs. Tympanometry was also normal and acoustic reflexes were obtainable at typical levels ipsi- and contra-laterally. He had a normal speech audiogram and performed well on the speech-in-noise test, both monaurally and binaurally. He had a strong history of noise exposure (NIR 2), arising from work with aircraft and from gunshot.

Peripheral auditory pathology was ruled out as the main cause of this patient's problems by his normal frequency resolution and tympanometry. A lesion at the brainstem level lesion was ruled out by his normal reflexes, normal temporal resolution and normal BMLDs. His strong history of noise exposure almost certainly explained the high

frequency loss, while his age (53 years) could explain some mild loss at lower frequencies. However, these minor losses were not felt to be a sufficient explanation of the patient's reported symptoms. It was concluded that the patient's problems originated at a central level, and were probably due to minor cerebral damage following his stroke.

In the report to the referring consultant it was pointed out that a neuropsychologist or neurologist might throw further light on the patient's problem, but that often spontaneous recovery effects after a stroke are larger than any effects of intervention. A speech therapist was recommended as being a more appropriate source of help, as he/she could give the patient support and encouragement, as well as monitoring his progress.

The findings were also explained to the patient, and he was given advice on hearing tactics and reassurance about his hearing.

APPENDIX 3.4 INSTRUCTIONS FOR TESTS IN STAGE II

This appendix contains the verbal instructions given to all subjects for all psychoacoustic, central/cognitive and performance tests new to stage II.

1. PSYCHOACOUSTIC TESTS

(a) Notched Noise Technique

At the moment this flashing GREEN light means that the test is ready to start. When you begin the following will happen:-

These three ORANGE lights will flash, one after the other. At the same time as EACH of the lights flash you will hear a rushing sound.

At the same time as just ONE of the lights flashes you will ALSO hear some short bleeps; like this:-

After all three lights have flashed this RED light will light up. This means that the machine is waiting for an answer from you.

What you must then do is remember with which light flash you heard BOTH the rushing noise AND the bleeps. You should then press the pad underneath that light. You are in effect pressing the pad where you heard the ODD SOUND OUT; i.e the only sound WITH bleeps.

DO NOT press the pad until the RED light comes on, as the machine will not register your response.

When you have pressed the pad the next stimulus will start.

As the test goes on the BLEEPs will gradually get quieter, until you can no longer hear them. As this happens you'll find that you are judging more on hearing a slight difference in one of the sounds (the odd sound out) than on actually hearing the bleeps themselves.

Eventually you won't be certain where the bleeps came. When this happens I want you to make as good a guess as you can as to which light they came with. The reason for this is that the test is run by a computer. It makes the bleeps quieter and quieter until you can't hear them, then when you get an answer wrong it makes them louder again.

The test will carry on for a little while, when it is over all the lights will go out, I will then come in and instruct you further.

You'll only hear what I have described in one ear, starting with the left.

Just a couple of additional things to note:-

(i) Any time the RED light is on the machine is waiting for you to press a button. Sometimes, if you don't press quite right, the machine doesn't register your response, so if you do see the red light on (even if you have just responded) press once more on the pad where you think the bleeps came.

(ii) The pads need a fairly firm push with your finger; don't use your nails.

(iii) You will notice that immediately you have made your response, just before the next stimulus begins, one of the ORANGE lights will flash briefly. The one that lights up is the correct answer. This gives you a way of checking whether you are listening for the right sounds.

As I said at the beginning, when the GREEN light is flashing it means that the test is ready to begin. In order to start the run you must press the pad underneath it. So, when I am out of the room, and you are ready, press the pad and the test will start.

(b) Binaural Masking Level Differences (BMLDs)

This test is very similar to the last test that you did in here. It works on the same procedure as before. This time, the following will happen:-

After you have pressed the pad under the GREEN light to start you will immediately hear a continuous, fairly loud, rushing sound; you should try to ignore this.

The ORANGE lights will then flash after the other. This time though, instead of hearing some bleeps you will hear a low sound like an owl-hoot.

When the RED light comes on you must press the pad under the light where you heard the low tone in addition to the continuous rushing sound; i.e. you are again, in effect, listening for the ODD SOUND OUT.

After you have responded the RED light will go out, and the next stimulus will then start.

As the test goes on the TONE will gradually get softer, until you can no longer hear it. Once again I want you to make as good a guess as you can as to where you think it came.

This time you will be hearing the sounds in BOTH ears.

So when I am out of the room, and you are ready to begin, press the pad under the GREEN light and the test will start.

(c) GAP DETECTION TASK

Once again this test works along the same lines as the last couple you did in here. The differences this time are as follows:-

You do not have to detect a hoot or a whistle in the sound this time, but a short 'pause' instead.

At the same time as EACH of the lights flashes you will hear a rushing sound. The rushing sound that comes with one of the flashes will differ from the other two, in that it will have a short gap in it. It will sound something like this, rather than like this.....

When the RED light comes on you should press the pad under the light in which the rushing sound had the small gap in it. Again, then, you are listening for the ODD SOUND OUT; this time the odd sound out is the sound with a short gap in it.

As the test goes on, the gap will get shorter and

shorter. As it does so, you will find that you can't actually hear the gap as a clear pause, but more as a 'blip'. It is this slight difference that you should listen out for.

Throughout the whole test you might notice a fairly quiet continuous rushing sound, just ignore it.

You'll just hear the sounds in one ear at a time, starting with the left.

So again, when I am out of the room, and you are ready to begin, press the pad under the green light to start the test.

2. COGNITIVE/LINGUISTIC TESTS

Dichotic Listening Experiment

You are going to hear a series of single words spoken one after the other. You will hear different words in each ear simultaneously; for instance you may hear the word CAT in your LEFT ear, and, at exactly the same time, you may hear the word HOW in your RIGHT ear.

Your task is to listen to the words that come into your left ear or right ear or to both ears, and to report aloud any words that fall into a certain category.

To begin with, you will do a practice list during which time you should concentrate on what you hear in your LEFT ear, ignore what you hear in the right, and report aloud any words in the category "relatives" (e.g. mother,

father, brother, sister etc).

After this you will start the actual test, during which you should always report aloud words in the category "FOOD AND DRINK" (e.g peach, meat, pancake etc), but also you will be repeating aloud words that begin with a certain letter of the alphabet.

I will tell you which letter of the alphabet to listen for, and which ear or ears to concentrate upon at the start of each list.

To begin with, the words in the practice list come very slowly, after this they will speed up a bit. This is the speed they will be during the actual test.

If, during any of the lists, you forget which ear to listen to, or which letter you are monitoring for, do stop and ask, because this is not a test of your memory.

You need not worry that you will miss the next word while reporting the last one, since they are sufficiently separated as to prevent this happening.

To start with, then, I want you to concentrate on the words you hear in your LEFT ear, and report aloud any "RELATIVES".

(b) Sentence Monitoring Test

You are going to hear a series of sentences. Just before each sentence begins a word will flash up on the screen. This word defines the TARGET CATEGORY.

Shortly after you have read the word you will hear a sentence spoken over the headphones.

Your task is to press a button on the response box as quickly as you can after you have heard a word in the sentence that falls in the TARGET CATEGORY.

For instance, the TARGET CATEGORY may be "A NAME" . You may then hear the sentence:-

He was looking everywhere for his friend called JANE"

Immediately you hear the word JANE you should press the button.

There are many different sentences, and there are 10 different TARGET CATEGORIES. There are also 4 different types of sentence that you will hear:-

(i) Some sentences will sound normal and their content will be usual; for example:-

"He was looking every where for his friend called Jane"

(ii) Some sentences will sound possible but will have a fairly unusual content; for example:-

"He found Jane under the chimney"

(iii) Some sentences will definitely sound unusual because the word order will be muddled up; for example:-

"Chimney the Jane found he under"

(iv) Some sentences will sound normal, and will have normal content but will not contain a word in the TARGET CATEGORY.

So, you must listen for a word in the TARGET CATEGORY and press the button as quickly as you can but without making too many mistakes. If the sentence does not contain a word in the TARGET CATEGORY then don't press a button, the next sentence will automatically start shortly afterwards.

At the start of the test the words "PRESS ANY BUTTON TO BEGIN" will appear on the screen. When you are ready, then, go ahead and start the test.

(c) Audiovisual Test

This test is more or less the same as the one you did next door when you listened to sentences and repeated them back to me. The difference this time is that as well as hearing the sentence, you will also see a man saying it, so you'll be able to use clues from lipreading as well as hearing.

This is what will happen:

A man's face will come on the screen, he will say a sentence that you will both see on the television screen and hear through the headphones. I want you to repeat back to me what you think he said. We will then move on to the next sentence. Do not worry if you don't understand everything he said; just repeat back as much

as you can.

As well as hearing the man's voice you will also hear a hissing sound in the background. Try to ignore it.

You are going to hear three lists of sentences. The first will be as I just explained. For the second list I will turn off the vision. For the final list you will have the vision again to help you.

4. PERFORMANCE TESTS

(a) Adaptive PFFIN test

Subjective Condition

You are going to hear some short simple sentences one after another. As well as hearing the sentences you will also hear some background noise. The background noise will sometimes be a HISSING NOISE and sometimes a STRANGE SPEECH-LIKE BABBLE (it is, in fact, speech played backwards).

The loudness of the noise will remain at one level throughout the test. The loudness of the sentences, however, will vary.

What you are going to do is alter the loudness of the sentences until they reach a level at which you feel they are "just loud enough for you TO UNDERSTAND EVERYTHING THAT IS BEING SAID" .

I want you to do this in the following way:-

Listen to the sentences carefully, then say whether you need the sentences made louder or quieter in order for you to be able to JUST UNDERSTAND THE MEANING OF EVERYTHING THAT IS BEING SAID.

You should do this by saying "LOUDER" when you want the sentences made LOUDER and "QUIETER" if you feel that by forcing yourself you will be able to hear the sentences if they were made quieter.

You should carry on saying "louder" or "quieter" until we reach the end of the list. Don't give me this feedback after each sentence, but listen to two or three, make up your mind and then let me know.

We will then repeat the same procedure using a different list and a different kind of background noise.

To begin with the sentences will be loud enough for you to easily hear them, so to begin with you should say "QUIETER" a few times. Eventually the sentences will become too quiet for you to hear them, so then you should say "louder".

Objective Condition

Once again you will be hearing some sentences with two types of noise in the background. Again, I want you to listen to the sentences and ignore the background noise. This time, however, there are silent intervals between each sentence. Your task is to actually say during the silent intervals what you think you heard, not to judge how well you can hear it.

After each sentence, then, I want you to repeat back as much or as little as you heard of that sentence. Don't worry if what you heard doesn't make a complete sentence, because I score the test by counting every word you get correct, not by whole sentences.

At the end of the sentences we will move on to another list, with a different type of background noise.

(b) FAAF Test

This test is very straight forward. You are going to hear a man say the sentence:

"Can you hear clearly"

The will vary for each trial.

Just before the man says the sentence, four words will come up on the screen. One of these words will be What you must do is decide which of the four words you have just heard, then if you think it was word 1 on the screen press button 1, if word 2 press button 2, etc.

Just carry on like this until the test stops.

A couple of points to note are:

(1) You must make a decision EVERY time, even if you are not sure. The test will not continue until you have pressed a button

(2) The man's voice will sound very muffled, this is done on purpose.

When I am out of the room the instructions I just gave you will appear on the screen. Read them and then press any button to start the test.

APPENDIX 3.5 - PREPARATION OF THE LISTS FOR THE
ADAPTIVE PFFIN TEST

Rationale

Results from the PFFIN test in stage 1 showed that sentences within BKB lists 5,6,7,8 were not of equivalent difficulty. For example some sentences were reported correctly by 100% of listeners (e.g list 6, sentence 8), while other sentences were not reported correctly by any listeners (list 6, sentence 11). An adaptive procedure requires that sentences within one list be of equivalent, or at least similar difficulty, since the levels of presentation (and hence levels of difficulty) of each sentence are interrelated. For this reason results from the PFFIN test in stage 1 were used to construct new lists of BKB sentences equivalent to one another, both in terms of overall difficulty, and in terms of individual sentences within each list being of equal difficulty. Total homogeneity would be ideal but was not possible, so adjacent sentences were of nearly equivalent difficulty, i.e sentence 1 in list 1 was chosen to be of equal difficulty to sentence 1 in lists 2, 3 and 4, etc. Here 'equal' means +/- 9.8% (for test sentences) in the mean data from stage 1. Due to the variation in sentence difficulty, consecutive sentences within each list were of similar, but not identical difficulty (maximum variation between consecutive sentences was 26.3%, mean variation was 7.4%).

The relative difficulty of each sentence was determined as follows. Data from stage I, in terms of the number of key-words correctly reported for each of the 64 sentences used in the PFFIN test, were available from 56 listeners. The percentage of subjects correctly reporting all key-

words was calculated for each of the 64 sentences. These ratings were corrected for practice effects as follows:

The BKB lists used in stage I (5,6,8,9) were shown by Pearce & Coles (1980) to be of equivalent in terms of their acoustic difficulty and their contextual predictability. The lists were run in two conditions, list order remaining the same for all subjects, while conditions were counterbalanced in ABBA and BAAB fashion. Therefore lists 5 and 8 were always the first list in each condition. Mean scores on each list show this to have given a practice effect:

List Number	Mean score (%)	Standard deviation
5	63.80	10.91
6	76.98	10.70
8	65.38	10.41
9	77.24	11.35

Student's t-tests show that scores for lists 5 and 8 differ from those of lists 6 and 9 significantly, but that no differences exist between lists 5 and 8, nor between lists 6 and 9. In order to correct for this practice effect the average score on lists 5 and 8 was differenced from the average score on lists 6 and 9:

$$(76.98+77.25)/2 - (63.80+65.38)/2 = 12.52$$

For all sentences in lists 5 and 8 the percentage of subjects reporting all keywords correctly was increased by half of this difference (6.26%). For all sentences in

lists 6 and 9 the percentage of subjects reporting all keywords correctly was decreased by half of this difference (6.26%). After correcting the data for these practice effects the resulting data were used as a difficulty rating for each BKB sentence.

New lists were then compiled in the following manner:

Each list was to contain 15 sentences, 10 test sentences and 5 practice, as recommended by Plomp & Mimpen (1979). The 40 test sentences were chosen from the total of 64 BKB sentences. Any sentence containing 4 key-words was discarded, as were all sentences of extreme difficulty/ease. The 4 easiest sentences were chosen as test sentence 1 for new BKB lists 1, 2, 3, and 4. The next 4 easiest were chosen for test sentences 2, etc.. Sentences were allocated to the new lists so that, as far as possible, after each sentence was allocated, the new lists remained of equivalent difficulty. This process continued until 10 test sentences for each new list had been allocated. The remaining 20 sentences were allocated to each new list as practice sentences, in the same way as above. This time, however, the 4 most difficult sentences were placed first.

The final new lists were thus of equal difficulty to one another. Within each practice list the sentences began very difficult and became gradually easier throughout the sentences. From test sentence 1 they became gradually more difficult again. The rationale for ordering the sentences in this way was as follows. An adaptive procedure works on the assumption that by altering the S/N ratio, a threshold will be reached at which the subject is correctly scoring a predetermined percent. It requires that for some trials the S/N ratio is too easy, and then for others it becomes too adverse. If sentences

had been ordered difficult to easy (or vice versa) such points of reversal might never have been achieved. It was decided to begin the practice sentences with the most difficult sentence, followed by the easier ones, so that one a subject had correctly repeated one sentence they would gain confidence by also repeating the following few sentences correctly. The practical effects of this systematic bias will be minor in the context of this experiment, because reversals are counted for the last ten items only. Also the aim of the experiment is to compare the performance of the two groups, rather than to study an absolute level of performance. The final new sentence lists and their difficulty ratings are given below.

New BKB Lists 1 to 4

The Key-words are underlined.

LIST 1

1. The sun melted the snow
2. The clever girls are reading
3. The cook cut some onions
4. The coat lies on a chair
5. The father's coming home
6. The matches lie on the shelf
7. The five men are working
8. They went on holiday
9. The car hit a wall
10. A letter fell on the mat
11. He climbed his ladder
12. She stood near her window
13. The paint dripped on the ground
14. The three girls are listening
15. The lorry drove up the road

LIST 2

1. The naughty girl's shouting
2. The cold milk's in a jug
3. The child drank some milk
4. The kitchen sink's empty
5. The bath towel was wet
6. The train had a bad crash
7. They're climbing the tree
8. The lady packed her bag
9. A sharp knife's dangerous
10. The train's moving fast
11. The table has three legs
12. The small boy was asleep
13. The book tells a story
14. The dinner plate's hot
15. They took some food

LIST 3

1. He's bringing his raincoat
2. He listens to his father
3. The footballer lost a boot
4. The lady goes to the shop
5. Men wear long trousers
6. The train had a bad crash
7. The shoes were very dirty
8. The match boxes are empty
9. He's washing his face
10. They're shopping for cheese
11. Somebody took the money
12. They wanted some potatoes
13. The ball broke the window
14. Baby broke his mug
15. Police are clearing the road

LIST 4

1. The pond water's dirty
2. The park's near the road
3. The mother stirs the tea
4. The dog made an angry noise
5. The light went out
6. The bus stopped suddenly
7. She writes to her brother
8. The family bought a house
9. A friend came for lunch
10. The jug stood on the shelf
11. She had her pocket money
12. The woman tidied her house
13. The boy forgot his book
14. They laughed at his story
15. The broom stood in the corner

The difficulty ratings of these sentences are:

NEW LIST 1		NEW LIST 2	
Original list	% correct ¹	Original list	% correct
6.7	0.0	5.15	1.9
6.14	9.7	5.16	15.5
5.9	17.4	9.15	18.0
8.16	34.5	5.5	25.1
6.8	96.5	5.1	100.0
-----		-----	
5.2	90.7	5.4	90.2
9.7	73.8	9.3	73.8
9.10	78.8	9.12	73.8
9.16	70.6	6.12	71.4
9.6	70.6	9.14	68.9
8.4	67.3	9.5	64.0
9.4	61.3	6.5	57.9
6.1	52.1	9.1	49.2
8.15	29.5	9.13	39.4
6.10	27.0	6.13	21.2

Mean=62.17 SD = 19.5 Mean=60.98 SD = 18.9

NEW LIST 3		NEW LIST 4	
original list	% correct	original list	% correct
6.11	0.0	8.9	0.0
9.8	14.8	5.8	5.8
8.14	19.7	6.2	17.4
6.6	30.9	5.10	38.6
6.4	83.0	5.13	91.0
-----		-----	
5.4	84.9	8.12	83.7
9.9	80.4	8.13	82.0
8.3	73.8	8.5	72.2
5.11	73.4	8.2	72.2
8.8	68.9	8.6	70.6
5.12	65.6	6.9	65.6
5.14	61.8	6.16	59.9
8.7	49.2	8.1	49.2
9.11	47.6	6.3	32.8
8.11	21.3	6.15	23.2

Mean=62.69 SD=17.9 Mean=61.13 SD=19.2

¹% correct = % of subjects from OAD stage I who repeated all keywords in that sentence correctly in PFFIN test used in stage I.

PAGE

NUMBERING

AS ORIGINAL

APPENDIX 3.6 - SENTENCES USED IN THE AUDIOVISUAL TEST

Target words are underlined:

List 1 - used as practice, presented audiovisually

The girl knew the story
He reached for a cup
The lady was quite cross
The rope was too short
She's listening to the radio
The husband cleaned the car
They locked the safe
The postman leaned on the fence
The china vase was broken
The other team won
The leaves dropped from the trees
The men watched the race
The bird's building a nest
The woman called her dog
They're waving at the train

List 2 - a test list, presented auditorily only

The cat scratched the chair
She tapped at the window
The man painted the gate
He slid on the floor
They're lifting the box
The woman listened to her friend
The driver hooted his horn
The cake tasted nice
The sailor stood on the deck
The young girls were pretty
The back door was shut
They ainted the ceiling
The tree lost its leaves
The young mother's shopping

List 3 - a test list, presented audiovisually

The girl sharpened her pencil
She closed her eyes
The puppy licked his master
The plant grows on the wall
The family's having a picnic
The train arrived on time
They won the game
The lady waited for her husband
The post office was near
They rowed the boat
The old fox was sly
The baby lost his rattle
He dug with his spade
The boiled egg was soft
The two ladies were watching

APPENDIX 3.7 - PREPARATION OF THE DICHOTIC LISTENING TEST

3 different lists of 56 word pairs were prepared. Each list was presented in each of three conditions (see main text).

Preparatory Procedure

156 monosyllabic and 156 bisyllabic words common in the English language were generated, as were 12 monosyllabic and 12 bisyllabic words in the category FOOD AND DRINK. Words were paired up, monosyllabic with monosyllabic, bisyllabic with bisyllabic. Words in each pair were chosen from informal listening by the experimenter to have similarly placed p-centres (Morton et al, 1976), so that, despite slight differences in the timing of energy growth in the initial consonant and vowel, they would sound as though they had been output simultaneously. Each word was then recorded onto a single channel of a tape, in a sound attenuating room. This tape was then played into a Z-2 computer wave-form analysing package to remove the silent intervals at the start and end of each word. Three different dichotic lists, of 56 word pairs each were devised. Each included eight words in the target category. The words were then output in pairs by the computer onto tape in the following way.

Each of the three lists of word pairs output so it could be presented in each test condition. For the left ear report condition all target words were output onto the left channel of the tape from the computer, for the right ear report condition all target words were output onto the right channel of the tape from the computer, and for the both ear report condition half of the target words

were output onto the left channel, half onto the right channel. All other words were output onto the same channel for each condition. The resulting tape consisted of nine dichotic lists, with 56 word pairs in each, eight of which contained a target word. The order of conditions and of the three original dichotic lists was counterbalanced as follows:

Original List	Actual List	Condition
A	1	Left
B	2	Right
C	3	Both
A	4	Right
B	5	Both
C	6	Left
A	7	Both
B	8	Left
C	9	Right

The target words in each list were:

LIST A:-	YOGHURT CHICKEN	SOUP BREAD	CRISPS ICECREAM	JAM PIZZA
LIST B:-	CURRY EGG	TEA ONION	BISCUIT CARROT	PEAS BEANS
LIST C:-	MILK CABBAGE	APPLE SUGAR	PIE FISH	CHEESE BUTTER

Pilot tests showed the test to be very easy. To avoid ceiling effects in the final results it was desirable to make the test more difficult. In order to avoid

rerecording the test with additional target words added, it was decided to choose further target words already present in the list. This was done by adding a phonetic monitoring category in the form of 'words beginning with a specific letter of the alphabet'. The actual phonetic targets differed between lists, but were chosen so that, as far as possible, the list remained balanced in terms of the total number of target words they contained. Perfect balancing was not possible. Table 1 shows the numbers of phonetic targets, and the total number of targets in each list.

Table 1
Numbers and letter of phonetic targets in each dichotic list, and the total number of targets in each list.

List Number	Phonetic target	Number of phonetic targets	Total number of target
1	P	5	13
2	S	5	14
3	SH	5	13
4	S	6	14
5	W	5	13
6	S	7	16
7	H	6	14
8	H	5	13
9	L	6	14

In some instance a word in the semantic category began with the same letter as the phonetic category, hence the final numbers of targets in, for example, lists 1 and 2 differ.

The total number of targets (phonetic and semantic) in each condition was:

Left ear report: 42, Right Ear report: 42,

Both ears report: 40.

The final dichotic lists were as follows. All target words are underlined.

LIST 1	LIST 2	LIST 3
Left ear + P	Right ear + S	Both ears + SH
tickle/yellow	waiting/rubbish	stupid/picture
skate/knife	church/knit	fan/jet
crime/lost	mist/ <u>smile</u>	thin/milk
<u>yoghurt</u> /clever	police/ <u>today</u>	watch/ <u>leaf</u>
laughing/single	river/ <u>curry</u>	both/chair
<u>prepare</u> /hello	tailor/carpet	duster/ <u>shoelace</u>
lion/vicar	quite/bus	camera/ <u>under</u>
know/ <u>smile</u>	phone/ <u>skate</u>	wood/fault
box/east	brother/worry	teeth/come
<u>pen</u> /eye	thing/zip	silly/ <u>apple</u>
<u>soup</u> /bought	hello/ <u>sister</u>	chatter/angry
garden/doing	fault/ <u>cold</u>	sitting/likely
chair/felt	open/picture	have/new
lady/under	boy/ <u>tea</u>	present/before
shop/read	flat/ <u>star</u>	<u>sheet</u> /rich
bridge/nose	sooner/poem	<u>help</u> /tight
magic/empty	hurry/engine	daily/traffic
vacant/pillow	east/glad	dash/pot
<u>crisps</u> /stick	watch/hill	<u>pie</u> /aunt
today/guitar	postman/ <u>biscuit</u>	<u>slide</u> /late
rake/cold	event/pencil	marry/under
<u>pile</u> /cross	ladder/ <u>shoelace</u>	pillow/ladder
candle/brother	hand/more	<u>shoe</u> /band
face/ring	camera/angry	between/enough
<u>bread</u> /more	blue/gift	train/ <u>cheese</u>
<u>sheet</u> /like	tug/bull	poor/brush
late/thing	warm/ <u>peas</u>	himself/sudden
window/letter	tailor/garden	bow/tree
knit/book	homely/prepare	party/started
three/choose	you/park	told/ <u>shook</u>
concern/story	necklace/broken	lady/ <u>travel</u>
string/come	traffic/rainy	homely/faster

jam/end
happy/kitten
plug/you
muddle/puppy
marry/reason
fashion/cotton
chicken/vicar
hurry/pocket
lighthouse/blank
leaf/boy
record/stupid
faster/present
chase/teeth
dog/girl
icecream/jealous
sudden/pencil
paper/running
letter/event
rich/sale
have/slide
pizza/hiding
team/band
traffic/handle
gift/brush

egg/cross
idle/cellar
ship/felt
paper/idle
end/tree
record/story
between/chatter
sofa/onion
dog/pen
vicar/hiding
happy/carpet
running/fashion
mood/ring
mother/carrot
pile/team
day/bridge
train/church
angel/lion
string/house
mood/beans
police/away
rest/sky
peace/wind
pot/bow

cabbage/yellow
good/lost
sister/poem
key/like
park/read
mirror/open
sugar/early
rainy/angel
vest/hill
hand/square
told/shop
giving/candle
fish/deal
ladder/muddy
mist/case
sale/glad
vacant/baby
sister/ballet
drive/year
tickle/butter
moment/cellar
crime/day
reason/weather
cotton/raincoat

LIST 4

Right ear + S

tickle/yellow
skate/knife
crime/lost
clever/yoghurt
laughing/single
prepare/hello
lion/vicar
know/smile
box/east
pen/eye
bought/soup
garden/doing
chair/felt
lady/under
shop/read
bridge/nose
magic/empty
vacant/pillow

LIST 5

Both ears + W

waiting/rubbish
church/knit
mist/smile
police/today
curry/river
tailor/carpet
quite/bus
phone/skate
brother/worry
thing/zip
hello/sister
fault/cold
open/picture
boy/tea
flat/star
sooner/poem
hurry/engine
east/glad

LIST 6

Left ear + S

stupid/picture
fan/jet
milk/thin
watch/leaf
both/chair
duster/shoelace
camera/under
wood/fault
teeth/come
apple/silly
chatter/angry
sitting/likely
have/new
present/before
sheet/rich
help/tight
daily/traffic
dash/pot

stick/crisps
today/guitar
rake/cold
pile/cross
candle/brother
face/ring
more/bread
sheet/like
late/thing
window/letter
knit/book
three/choose
concern/story
string/come
end/jam
happy/kitten
plug/you
muddle/puppy
marry/reason
fashion/cotton
vicar/chicken
hurry/pocket
lighthouse/blanket
leaf/boy
record/stupid
faster/present
chase/teeth
dog/girl
jealous/icecream
sudden/pencil
paper/running
letter/event
rich/sale
have/slide
hiding/pizza
team/band
traffic/handle
gift/brush

watch/hill
postman/biscuit
event/pencil
ladder/shoelace
hand/more
camera/angry
blue/gift
tug/bull
peas/warm
tailor/garden
homely/prepare
you/park
necklace/broken
traffic/rainy
egg/cross
idle/cellar
ship/felt
paper/idle
end/tree
record/story
between/chatter
onion/sofa
dog/pen
vicar/hiding
happy/carpet
running/fashion
mood/ring
mother/carrot
pile/team
day/bridge
train/church
angel/lion
string/house
mood/beans
police/away
rest/sky
peace/wind
pot/bow

pie/aunt
slide/late
marry/under
pillow/ladder
shoe/band
between/enough
cheese/train
poor/brush
himself/sudden
bow/tree
party/started
told/shook
lady/travel
homely/faster
cabbage/yellow
good/lost
sister/poem
key/like
park/read
mirror/open
sugar/early
rainy/angel
vest/hill
hand/square
told/shop
giving/candle
fish/deal
ladder/muddy
mist/case
sale/glad
vacant/baby
sister/ballet
drive/year
butter/ tickle
moment/cellar
crime/day
reason/weather
cotton/raincoat

LIST 7

Both ears + H

tickle/yellow
skate/knife
crime/lost
clever/yoghurt
laughing/single

LIST 8

Left ear + H

waiting/rubbish
church/knit
mist/smile
police/today
curry/river

LIST 9

Right ear + L

stupid/picture
fan/jet
thin/milk
watch/leaf
both/chair

prepare/hello
lion/vicar
know/smile
box/east
pen/eye
bought/soup
garden/doing
chair/felt
lady/under
shop/read
bridge/nose
magic/empty
vacant/pillow
stick/crisps
today/guitar
rake/cold
pile/cross
candle/brother
face/ring
bread/more
sheet/like
late/thing
window/letter
knit/book
three/choose
concern/story
string/come
jam/end
happy/kitten
plug/you
muddle/puppy
marry/reason
fashion/cotton
vicar/chicken
hurry/pocket
lighthouse/blanket
leaf/boy
record/stupid
faster/present
chase/teeth
dog/girl
icecream/jealous
sudden/pencil
paper/running
letter/event
rich/sale
have/slide
pizza/hiding
team/band
traffic/handle
gift/brush

tailor/carpet
quite/bus
phone/skate
brother/worry
thing/zip
hello/sister
fault/cold
open/picture
tea/boy
flat/star
sooner/poem
hurry/engine
east/glad
watch/hill
biscuit/postman
event/pencil
ladder/shoelace
hand/more
camera/angry
blue/gift
tug/bull
peas/warm
tailor/garden
homely/prepare
you/park
necklace/broken
traffic/rainy
egg/cross
idle/cellar
ship/felt
paper/idle
end/tree
record/story
between/chatter
onion/sofa
dog/pen
vicar/hiding
happy/carpet
running/fashion
mood/ring
carrot/mother
pile/team
day/bridge
train/church
angel/lion
string/house
beans/mood
police/away
rest/sky
peace/wind
pot/bow

duster/shoelace
camera/under
wood/fault
teeth/come
silly/apple
chatter/angry
sitting/likely
have/new
present/before
sheet/rich
help/tight
daily/traffic
dash/pot
aunt/pie
slide/late
marry/under
pillow/ladder
shoe/band
between/enough
train/cheese
poor/brush
himself/sudden
bow/tree
party/started
told/shook
lady/travel
homely/faster
yellow/cabbage
good/lost
sister/poem
key/like
park/read
mirror/open
early/sugar
rainy/angel
vest/hill
hand/square
told/shop
giving/candle
deal/fish
ladder/muddy
mist/case
sale/glad
vacant/baby
sister/ballet
drive/year
tickle/butter
moment/cellar
crime/day
reason/weather
cotton/raincoat

APPENDIX 3.8 Construction and piloting of the
Sentence-Monitoring Experiment

A. Construction of 'predictable' and 'unpredictable'
sentences

Two target words, common in the English language, were chosen from each of ten simple categories (see below), giving a total of twenty different target words. Sentences were then prepared for each of four conditions, as follows:

(1) "Semantically and syntactically predictable"
sentences

20 sentences were composed by the experimenter. Each sentence contained a different target word. The content of the sentence prior to the target word was intended to make that target word highly predictable. The number of words in each sentence ranged from 7 to 12. The position of the target word varied from being the last word in the sentence to being fifth from last in the sentence.

(2) "Syntactically predictable and semantically
unpredictable" sentences

Using the same vocabulary (as far as possible) 20 more sentences were constructed, with one target word in each. The target word was unpredictable from the prior content of the sentence.

This gave 40 sentences, or 20 pairs of sentences, i.e. for each target word there was a predictable and an unpredictable sentence. Sentence length and position of target word was identical for each sentence in a pair.

B. Piloting of Sentences

A pilot experiment was carried out to check the predictability status of the target word in each sentence. Its aim was to check that target words in the newly constructed sentences differed materially in predictability as intended. For speed and ease of scoring the pilot experiment was carried out in written, rather than in the spoken form of the actual experiment. This posed one difficulty: during aural presentation words are heard sequentially, that is, a listener cannot hear words from the end of a sentence before hearing those at the start, during visual presentation there is no such constraint. As related to a reaction time experiment, then, subjects partly base their response on information heard prior to the target word. It was therefore necessary to place subjects in the visually presented pilot experiment under the same constraints. The pilot experiment was carried out as follows:

Subjects

Subjects were 24 school children of mixed sex, aged between 12 and 13 years of age, attending a local school. The experimenter was allocated one school period in which to carry out the experiment.

Procedure

Target words, and any words in the sentence occurring after the target word were removed from each of the 40 sentences. Sentences were printed in random order onto an answer sheet. Subjects were instructed by the experimenter to complete each sentence with a simple word (or, where necessary, with two or three words) that completed the sentence. It was emphasised that these words should be simple and come quickly to mind. They were asked not to think too long about any one sentence, and to work as quickly as they could.

Results

Sentences were scored as being appropriately constructed if:

(i) the subject completed the sentence with a word in the target category for a 'predictable' sentence, or

(ii) the subject did not complete the sentence with a word in the target category for a 'non-predictable' sentence.

The percentage of subjects reporting a correct answer was recorded. If this was less than 88% the sentence was replaced by one with a target word of apparently more extreme low or high predictability. This resulted in 3 sentences in the predictable set and 6 in the unpredictable set being replaced. From the 20 predictable and 20 non-predictable sentences, sentences in the remaining 2 experimental conditions were devised.

(3) "Syntactically and semantically unpredictable"
sentences

These were constructed by randomising the order of words in each predictable sentence. There were two constraints on this randomisation:

- (a) all syntactic structure was removed
- (b) the target word always fell in the same position in the new sentence as it did in the predictable sentence.

(4) "Null" sentences

These sentences were syntactically and semantically correct and likely, but no target words were included in the sentence. As far as possible, they were constructed from vocabulary used for the predictable and unpredictable sentences. They constitute stimuli for 'blank' trials.

A total of 80 sentences were constructed by this procedure (see below). The target word is printed in capital letters, in brackets at the end of each sentence is the condition number of each sentence.

Category:

ADJECTIVE OF EMOTION

- When she passed her exams she was very HAPPY (1)
- He jumped because the barking of the dog was HAPPY (2)
- She her had passed very was when she exams HAPPY (3)
- Father smiled broadly and so I knew he was right (4)

Father broke his favourite mug and so he was SAD
that night (1)
The sun was shining very brightly in the SAD sky
today (2)
The so father mug broke he was SAD and favourite (3)
The holiday ended and so everyone had to go back
home (4)

FOOD

We usually have a joint of roast BEEF for lunch on
Sunday (1)
In the old car they saw some BEEF under the seat (2)
Usually joint have we a lunch for BEEF of Sunday
on roast (3)
Father often spends a long time in our kitchen
cooking (4)

The boy hated eating greasy fried EGGS for breakfast (1)
In the old wardrobe they found EGGS to eat (2)
Eating the fried for greasy breakfast EGGS hated boy (3)
The cook wore her new clothes at work today (4)

FOOTWEAR

Mother said 'be careful not to scuff your BOOTS on the
pavement' (1)
Coming down the road the hitchiker saw a BOOT moving very
fast (2)
Careful your scuff on mother the not pavement BOOTS said
be to (3)
Our kind friend polished the big old wardrobe until it
was shiny (4)

Before an interview remember to polish your SHOES
well (1)
When you go outside always take your SHOES off (2)
Before polish interview an remember to well SHOES
your (3)
"Tie your laces in a double bow" she said (4)

VEHICLE

I was woken up by the revving of his CAR engine (1)
The cat licked his face and sat by the CAR door (2)
Was the of revving engine his I woken up CAR by (3)
They were so tired that they decided to go home
early (4)

The hitchiker was given a lift in a LORRY (1)
The football fans all greatly enjoyed watching
the LORRY (2)
A the lift a in hitchiker was given LORRY (3)
To arrive on time he took a quick route (4)

ANIMAL

They heard a soft purring from the little CAT in its
basket (1)
When people are cold they hold our CAT by its tail (2)
Purring its soft heard they in from CAT the basket
little (3)
In the garden they enjoyed watching the boy on the swing
(4)

He jumped because the barking of the DOG was loud (1)
Before his interviews he always polished the DOG very
well (2)
Barking he because loud of jumped the DOG the was (3)
Father opened a new tin of food for the baby (4)

FURNITURE

She has lots of blankets on her BED at night (1)
Yesterday it was very sunny but the BED was cold (2)
Lots night at on she her has BED blankets of (3)
My friend had a spare room where I could sleep (4)

People usually hang up their clothes in a WARDROBE (1)
The athlete always eats his food in the WARDROBE (2)
In a their hang clothes up people usually WARDROBE (3)
It is good to fold up your shirt neatly (4)

COLOUR

In the summer the sun usually shines in the clear BLUE
sky (1)
When the weather's cold she has many blankets on her
BLUE bed (2)
The summer in usually sky sun the shines clear the BLUE
in (3)
The boy laughed because the juggler looked very funny
in his hat (4)

His team always like wearing RED shorts (1)
The athlete is a fast RED man (2)
Always team his shorts wearing RED like (3)
When people blush they get very hot (4)

SPORT

The coach load of fans enjoyed the FOOTBALL match (1)
The juggler enjoyed himself very much at FOOTBALL
yesterday (2)
Fans of coach match enjoyed load the FOOTBALL the (3)
They usually play very loud music at his parties (4)

She bought a new racket specially to play TENNIS at his
house (1)
The cooks favourite pastime is watching TENNIS in the
rain (2)
Play bought a she house his at to TENNIS new specially
racket (3)
In the summer it is nice to play outside on the lawn (4)

CLOTHING

Mother washed and ironed his SHIRT before he left the
house (1)
You must capture your opponents SHIRT before you win
the game (2)
Before and ironed he left SHIRT house his the mother
washed (3)
You look very smart when you remember to brush your
hair (4)

His sister was very smartly dressed in her best SKIRT
and jacket (1)
Mother broke her favourite mug while carrying the new
SKIRT for me (2)
Her was smartly in best sister very dressed and SKIRT
his jacket (3)
Before his interview he was careful not to get at all
dirty (4)

MOTION VERB

Mother often misses the bus and must WALK home
instead (1)
She made a cup of tea and WALKED to bed (2)
Often and must bus instead the mother WALK misses
home (3)
The football fans stood in a queue for the bus (4)

The athlete is good at RUNNING very fast (1)
The wardrobe fell because he RAN into it (2)
Good the athlete very at RUNNING is fast (3)
I got home by taking the short route (4)

APPENDIX 3.9 LIST OF VARIABLES FROM STAGE II REFERRED TO
THROUGHOUT THE THESIS

The following pages contain the list of the variables from stage II that are referred to throughout the remainder of the thesis. For easy reference these sheets can be removed from this plastic folder.

Abbreviations that appear in the text are shown in brackets.

General Variable

- (1) Noise exposure history (NIR) - Scale of 0 (no noise exposure) to 4 (extreme noise exposure)

Psychoacoustic Variables

- (1) Average audiogram (AVAUDIO) = Binaural average of pure tone thresholds for frequencies: 0.125, 0.25, 0.5, 0.75, 1.0, 2.0, 3.0, 4.0, 6.0 & 8.0kHz
- (2) Average low audiogram (AVLOW) = Binaural average of pure tone thresholds for frequencies: 0.125, 0.25 & 0.5 kHz
- (3) Average mid audiogram (AVMID) = Binaural average of pure tone thresholds for frequencies: 0.75, 1.0 & 1.5kHz
- (4) Average high audiogram (AVHIGH) = Binaural average of pure tone thresholds for frequencies: 3.0, 4.0, 6.0 & 8.0kHz

(5) Masked thresholds :

- (i) 2kHz tone in bandpass noise: 0-1.5 and 2.5-8kHz
(MID-FREQUENCY NOTCH CONDITION)
- (ii) 2kHz tone in lowpass noise: 0-8kHz
(MID-FREQUENCY NO-NOTCH CONDITION)
- (iii) 500Hz tone (S_0N_0) in lowpass noise: 0-1kHz
(LOW-FREQUENCY MASKED THRESHOLD 1)
- (iv) 500Hz tone ($S_{pi}N_0$) in lowpass noise: 0-1kHz
(LOW-FREQUENCY MASKED THRESHOLD 2)

For some analyses the average of (iii) and (iv)
is used.

(6) Frequency Resolution ability

(7) Temporal resolution = Gap detection threshold

(8) Binaural masking level difference (BMLD)

Central/Cognitive Variables

- (1) Dichotic listening test focussed attention
condition (FOCUS)
- (2) Dichotic listening test divided attention
condition (DIVIDED)

- (3) Linguistic Ability = average reaction time during the sentence monitoring task under predictable, unpredictable and nonsense conditions
- (4) Audiovisual speech reception threshold in white noise (VSRTN)
- (5) Auditory speech reception threshold in white noise (ASRTN)
- (6) Lipreading ability

Personality-related Variables

- (1) 6 scales of anxiety - general, phobic, obsessive, somatic, depressive, hysterical.
- (2) Combined anxiety scale - equally weighted scale of general, phobic and somatic anxiety.
- (3) 9-point somatic anxiety scale from the OAD interview
- (4) Discrepancy between self-assessed hearing ability and actual performance ability using a white noise masker and babble masker = (PS-DISN and PS-DISB)

Performance and General variables

- (1) Speech discrimination in white noise (PSRTN)
- (2) Speech discrimination in babble (PSRTB)
- (3) Self-assessed speech discrimination ability in white noise (SSRTN)
- (4) Self-assessed speech discrimination ability in babble (SSRTB)
- (5) Speech discrimination in quiet = score on the FAAF test
- (6) Self-rated auditory disability
- (7) Self-rated auditory handicap

APPENDIX 3.10 - TEST OF RELIABILITY FOR MEASURES IN
THE STAGE II TEST BATTERY

(i) Reliability Matrices

Table 1 shows correlations between replicates of identical conditions for the OAD and control groups combined, OAD group alone and control group alone. The high correlations for both groups combined show that the tests are highly reproducible. Scores of OADs were, in all cases more reliable than those of controls. In the cases of gap left and gap right, SSRTB, PSRTN and PSRTB Fisher Z tests show these differences in reliability are significant. The standard deviation for the difference between test and retest scores are fairly similar for both groups (Table 2), except in the case of the gap thresholds and the SSRTN, this implies that differences in reliability correlations are not due to there being less variance of scores within the control group.

Table 1

Correlations between replicates of psychoacoustic and performance variables and Fisher Z test for differences in reliability between the OAD and control groups (if $Z > 1.95$ $p < 0.05$)

Variable	Correlation Coefficient			Fisher Z (btn OADs & Cons) p<
	OADs and controls	OADs alone	Controls alone	
GAPL ¹	0.81	0.84	0.66	2.07
GAPR ²	0.78	0.81	0.48	2.94
Low-freq1 ³	0.70	0.74	0.58	n.s.
Low-freq2 ⁴	0.74	0.75	0.69	n.s.
SSRTN	0.82	0.73	0.73	n.s.
SSRTB	0.81	0.82	0.51	2.89
PSRTN	0.63	0.71	0.28	2.89
PSRTB	0.76	0.87	0.49	3.81

- ¹Gap threshold left ear replicates;
²gap threshold right ear replicates;
³low-frequency masked threshold $S_0 N_0$;
⁴low-frequency masked threshold $S_{Pi} N_0$.

Table 2

Standard Deviations for the Test-Retest Results for OADs and Controls

Variable	Standard Deviation	
	OADs	Controls
GAPL ¹	4.1	3.4
GAPR ²	5.6	3.9
Low-Freq1 ³	1.9	2.2
Low-Freq2 ⁴	2.8	2.3
SSRTN	4.1	2.5
SSRTB	1.8	1.7
PSRTN	3.3	3.1
PSRTB	1.3	1.6

- ¹Gap threshold left ear replicates;
²gap threshold right ear replicates;
³low-frequency masked threshold $S_0 N_0$;
⁴low-frequency masked threshold $S_{Pi} N_0$.

Controls' gap detection thresholds were significantly less (i.e they improved) on the second replicate, but this was not the case for the OADs. This could contribute to the higher correlation between replicates seen in the OAD group.

There was a significant practice effect within both the OAD and control groups for performance on the PSRTN and PSRTB (table 3); the group by practice-effect interactions were not significant. Both groups became more conservative, i.e set less adverse S/N ratios on the second replicate of the SSRTN and SSRTB; once again, the group by practice-effect interactions were not significant.

Table 3

T-tests between replicates on the PFFIN test and the gap detection task within the OAD group and within the controls group. Group by improvement interactions are not significant

	OADs		Controls	
	t	p	t	P
GAPL	-0.29	n.s.	2.29	0.030
GAPR	-0.29	n.s	-0.51	n.s.
SSRTN	3.01	0.004	2.71	0.009
SSRTB	6.55	0.000	5.55	0.000
PSRTN	-4.41	0.001	-5.14	0.000
PSRTB	-5.88	0.000	-7.46	0.000

(ii) Ear asymmetries

(a) Pure Tone Sensitivity

Within both the OAD group and control group average pure tone audiogram was significantly lower (better) for the right ear than for the left (OADs: $t=4.53$, $p<0.0001$; Controls: $t=4.70$, $p<0.0001$). The asymmetry x group interaction was not significant. This asymmetry is probably due to a practice effect, since, unless a strong asymmetry in hearing was reported, left ear thresholds were determined before right ear thresholds.

(b) Psychoacoustic Tests

OADs had significantly better gap detection thresholds with the left ear than with right, and better mid-frequency masked thresholds (notch condition) with the left ear than with the right (Gap: $t=-2.28$, $p<0.03$; Masked threshold: $t=2.04$, $p<0.05$). No such asymmetries were found within the control group. The group x asymmetry interactions were not significant. On no other test were there left-right asymmetries.

(c) Dichotic Listening Test

Ear asymmetries (advantages) for performance on the dichotic listening test are discussed in section 3.4.2.4(a).

(iii) Differences between Conditions of the Sentence Monitoring Experiment

There were significant differences in reaction-time between the three test conditions for OADs and controls combined (Table 4). The differences in reaction time between the 'predictable' and 'unpredictable' condition, and between the 'predictable' and 'nonsense' conditions, were in the expected direction. That is, reaction time during the 'predictable' condition was faster than during the other two conditions. The difference in reaction time between the 'unpredictable' and 'nonsense' conditions were in the unexpected direction, reaction time being quickest during the 'nonsense' condition.

Table 4
Reaction-time differences between the three test conditions of the sentence-monitoring test

Condition	Mean difference (ms)	t-value	p<
Predictable/ unpredictable difference	-0.18	-17.35	0.000
Predictable/ nonsense difference	-0.13	-13.88	0.000
Unpredictable/ nonsense difference	0.05	5.20	0.000

This indicates two points. First, the significant differences between all three conditions shows that the test is valid; it does reflect linguistic processing via the use of contextual information. Second, the finding that reaction time was faster during the nonsense condition than during the 'unpredictable' condition, shows that contextual cues in this task can be so powerful that they override acoustic input.

APPENDIX 4.1 - QUESTIONNAIRE SENT TO CONSULTANTS
FOR EVALUATION OF THE OAD CLINIC

Evaluation form - IHR Clinic for Obscure Auditory
Dysfunction, Nottingham

Consultant:

Approximate number of patients referred to date:

(A) GENERAL COMMUNICATION WITH IHR

1. Did you feel that in the introductory material and interim reports that you have received the aims and purposes of the OAD clinic were explained:

- (i) Very clearly
- (ii) Adequately
- (iii) Not sufficiently clearly ?

2. The clinic serves a research function. Would you like to be kept more regularly in touch with the general findings from the research ?

- (i) Yes I would like more information
- (ii) The information implicit in the patient reports is enough
- (iii) I am only interested in the implications for individual patients.

(B) REPORTS ON PATIENTS

1. Is the quantity of information on patients:

- (i) Too detailed
- (ii) About right
- (ii) Not sufficiently detailed ?

2. In the patient reports are the implications of the findings made:

- (i) As clear as the condition permits
- (ii) Fairly clear
- (iii) Not clear enough ?

3. Is there any particular information you feel the reports lack ?

Please specify:

4. Knowing that Professor Haggard is involved in the project and that reports are checked by him, do you find it acceptable, from an etiquette point of view, that reports are now signed by Ms Saunders who is a relatively junior, though now experienced, researcher ?

- (i) Not acceptable
- (ii) Perfectly acceptable

(C) GENERAL

1. Have you received any direct and definite feedback about the quality of procedures and attention at the clinic from any patients or their GPs ?

- (i) All favourable
- (ii) Mostly favourable
- (iii) Neutral/contradictory feedback
- (iv) Mostly unfavourable
- (v) All unfavourable
- (vi) No comments received

2. Have you received any feedback about the overall value to the patient of attending the clinic?

- (i) All favourable
- (ii) Mostly favourable
- (iii) Neutral/contradictory feedback
- (iv) Mostly unfavourable
- (v) All unfavourable
- (vi) No comments received

3. Do you have any additional comments based on this feedback that might help IHR improve the service in the short term ?

4. Do you have any other comments of your own ?

A decision will eventually have to be made in the light of the research findings as to whether a service for OAD patients is in general best run on a Regional Centre basis or by ENT consultants within individual districts. The latter course, if favoured, could be assisted by a 'package' of interview guidelines, test procedures and diagnostic criteria, with appropriate briefing on their use.

5. Subject to practicalities and implications of the research findings would you prefer to:

(i) Have such a package to use within the local hospital

(ii) Don't feel strongly either way

(iii) Refer patients to a specialist regional clinic ?

6. If the service were to be devolved to the district level would you (or a suitable delegate) be able and willing to attend a one-day course in the Autumn that would present the research findings and explain the test 'package' ?

(i) Yes

(ii) Possibly, depending on the current circumstances

(iii) No

THANK YOU FOR YOUR HELP IN COMPLETING THIS QUESTIONNAIRE.

APPENDIX 4.2 - QUESTIONNAIRE SENT TO PATIENTS
FOR EVALUATION OF THE OAD CLINIC

Special Investigative Clinic in Nottingham

Name

Please circle the answer you think most appropriately describes your opinion.

Section 1 - The Test Battery

- (1) Did you find the tests interesting? Y N
- (2) In view of the variety of tests necessary to learn about your hearing, did you find the testing time:
- (i) Too long
 - (ii) About right, or as expected
 - (iii) Too short?
- (3) Were the instructions of what you had to do for each test:
- (i) Too simple
 - (ii) About right
 - (iii) Too complex?
- (4) Were the explanations of what each test was about:
- (i) Too complex
 - (ii) About right
 - (iii) Too complex?
- (5) Do you have any other comments about the tests?

Section 2 - Results and Advice

(1) After the testing the findings were explained to you. Did you find these explanations:

- (i) Too simple
- (ii) About right
- (iii) Too complex?

(2) You then received some suggestions about how to get around your difficulties. Did you find this advice:

- (i) Useful
- (ii) Of no use, because I already knew it
- (iii) Of no use, although I had not heard it before

(3) You were also sent/given a copy of the 'Hearing Tactics' leaflet with further advice about ways to get around your difficulties. Did you find this leaflet:

- (i) Clear and easy to follow
- (ii) Unclear and difficult to follow
- (ii) I have not looked at the leaflet

(4) All in all did the advice and reassurance make your visit to the clinic:

- (i) Very worthwhile
- (ii) Fairly worthwhile
- (iii) Not really worthwhile, yet not exactly a waste of time
- (iv) A waste of time?

(5) Do you have any other comments about the clinic?

APPENDIX 4.3 - PROGRAMME FOR CONSULTANTS' COURSE
ON OAD

Institute of Hearing Research 1-day Course

ASSESSMENT AND COUNSELLING FOR
OBSCURE AUDITORY DYSFUNCTION (OAD) .

"OAD" is the name given to the syndrome in patients with convincing reports of auditory disability, 'normal' audiograms, and no obvious organic cause. It is more common than formerly thought. This brief course covers theoretical and practical aspects of diagnosis and management arising from recent research, with an emphasis on setting up clinical procedures, on a scale consistent with current limitations on NHS resources.

Lecturers: MP Haggard, GH Saunders, D Field

- | | | |
|-------|---|-------|
| 9.45 | Coffee and Registration | |
| 10.15 | Background to the OAD problem: diagnostic mystery versus factors in service take-up | (MPH) |
| 10.50 | Summary of research findings and their applicability | (GHS) |
| 11.25 | Hearing tactics and their role | (DF) |
| 12.20 | Lunch | |
| 13.30 | Demonstrations of recommended tests | (GHS) |
| 14.10 | Alternative routes through clinical decisions and illustrative cases | (GHS) |
| 14.50 | Elements of counselling and questions to be answered | (DF) |
| 15.15 | Clinic planning and evaluation, and breakdown of major diagnostic categories | (MPH) |
| 15.40 | Tea and discussion | |
| 16.15 | End of course | |

APPENDIX 5.1 - LETTER SENT TO RECRUIT
PATIENT-CONTROLS

Dear

Earlier this year I understand you underwent a laparoscopy investigation in ward C31 of the Queens Medical Centre. Sister Dallison or one of her staff may have given you a letter and questionnaire from me asking whether you would kindly volunteer to take part in an investigative study about hearing. The study is taking place at the Institute of Hearing Research, which is on the University of Nottingham campus, just across the road from the Queens Medical Centre. In case you did not receive a letter I am writing ask whether you would be willing to take part in this study.

The purpose of the study is to learn about a group of people who report difficulties with their hearing, but in whom no abnormalities can be found with conventional hearing tests. It is expected that the study will enable us to advise hospitals about appropriate help for these people. I understand that the investigations you underwent led to a similar experience, in that laparoscopy examination failed to explain why you were suffering abdominal pain. For this reason it would be particularly interesting to compare your results with those of my patients.

You would do a variety of hearing tests that involve listening to quiet sounds, repeating back sentences and filling in a couple of questionnaires. None of the tests are in any way dangerous or painful. In total the tests take about 3.5 hours. You could come for testing at any time, inside or outside normal working hours, and you could do the tests in just one session or over two or three.

You will be paid 10 for taking part and will be bought lunch (if appropriate) and your travel expenses to and from the Institute will be paid.

If you are willing to take part in this study would you please complete the enclosed questionnaire and return it to me in the SAE provided. I will then get in touch to arrange an appointment for you to come for testing.

If you have any questions about the study please do not hesitate to telephone or write to me. I am grateful for your help and look forward to hearing from you.

APPENDIX 6.1 - COMPUTATION OF SELF-RATED AUDITORY
DISABILITY AND AUDITORY HANDICAP SCALES FROM THE
IHR HEARING QUESTIONNAIRE

The following nine questions from the IHR Hearing questionnaire were used by Lutman et al (1987) to compute 4 sub-scales of auditory disability and handicap.

- (1) Can you follow the television news when the volume is turned up only enough to suit other people?
- (2) Can you follow what is being said on the radio news when the volume is turned up only enough to suit other people?
- (3) Do you turn your head the wrong way when someone calls to you?
- (4) If you are with a group of people and someone you can't see starts to speak, are you able to tell where the person is sitting?
- (5) How difficult do you usually find it to follow somebody's conversation when other people are talking close by?
- (6) When in a quiet room with someone who is a clear speaker, how much difficulty do you have in understanding what they are saying?
- (7) How often does any hearing problem you may have restrict your enjoyment of social and personal life, compared to others around you?
- (8) Do you get a feeling of being cut off from things because of difficulty in hearing?
- (9) Do any difficulties you may have lead to embarrassment?

Questions 4, 5 & 6 are scored on a scale of 1-3.

Questions 1,2,3,7,8,9 are scored on a scale of 1-4.

In order that questions hold equal weight in the final sub-scale, all responses were rescaled to encompass the range 1-6.

Sub-scales were then computed by averaging the rescaled responses as follows:

- (a) Disability for everyday speech = questions 1, 2,
4 & 5
- (b) Disability for speech-in-quiet = question 6
- (c) Disability for localisation = questions 3 & 4
- (d) General disability = questions 1, 2, 3, 4, 5 & 6
- (e) Handicap sub-scale = questions 7, 8 & 9

APPENDIX 6.2 DISTRIBUTIONS OF SCORES ON VARIABLES
FROM THE STAGE II TEST BATTERY FROM 115 SUBJECTS

Values outside +/- 2.5 SDs from the mean were excluded from the analyses. These boundaries are marked on each histogram with vertical lines.

Distribution of PSRTN Scores for n=115

Mean=23.7, S.D. = 3.1

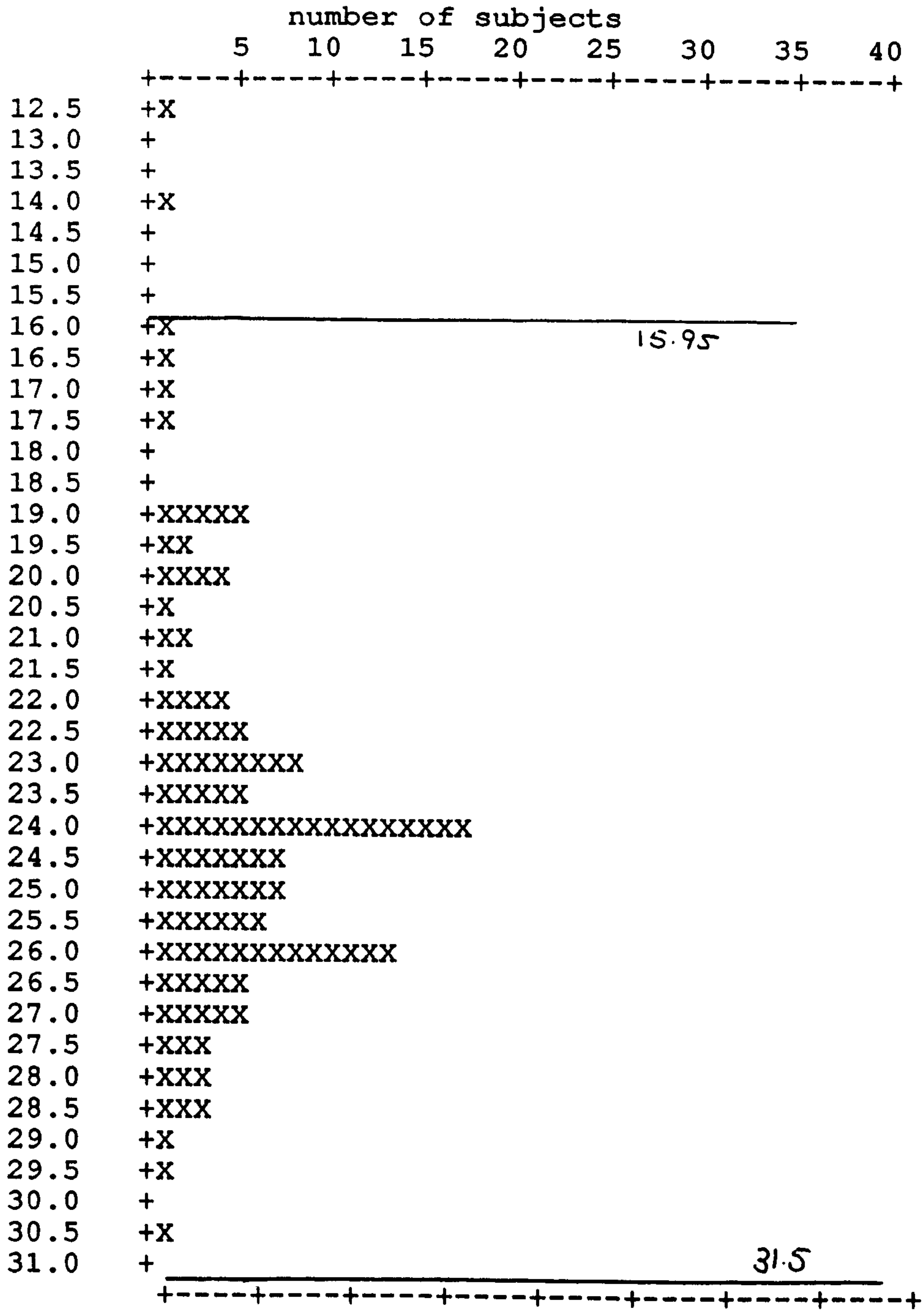

Distribution of PSRTB Scores for n=115

Mean=13.6, S.D=1.9

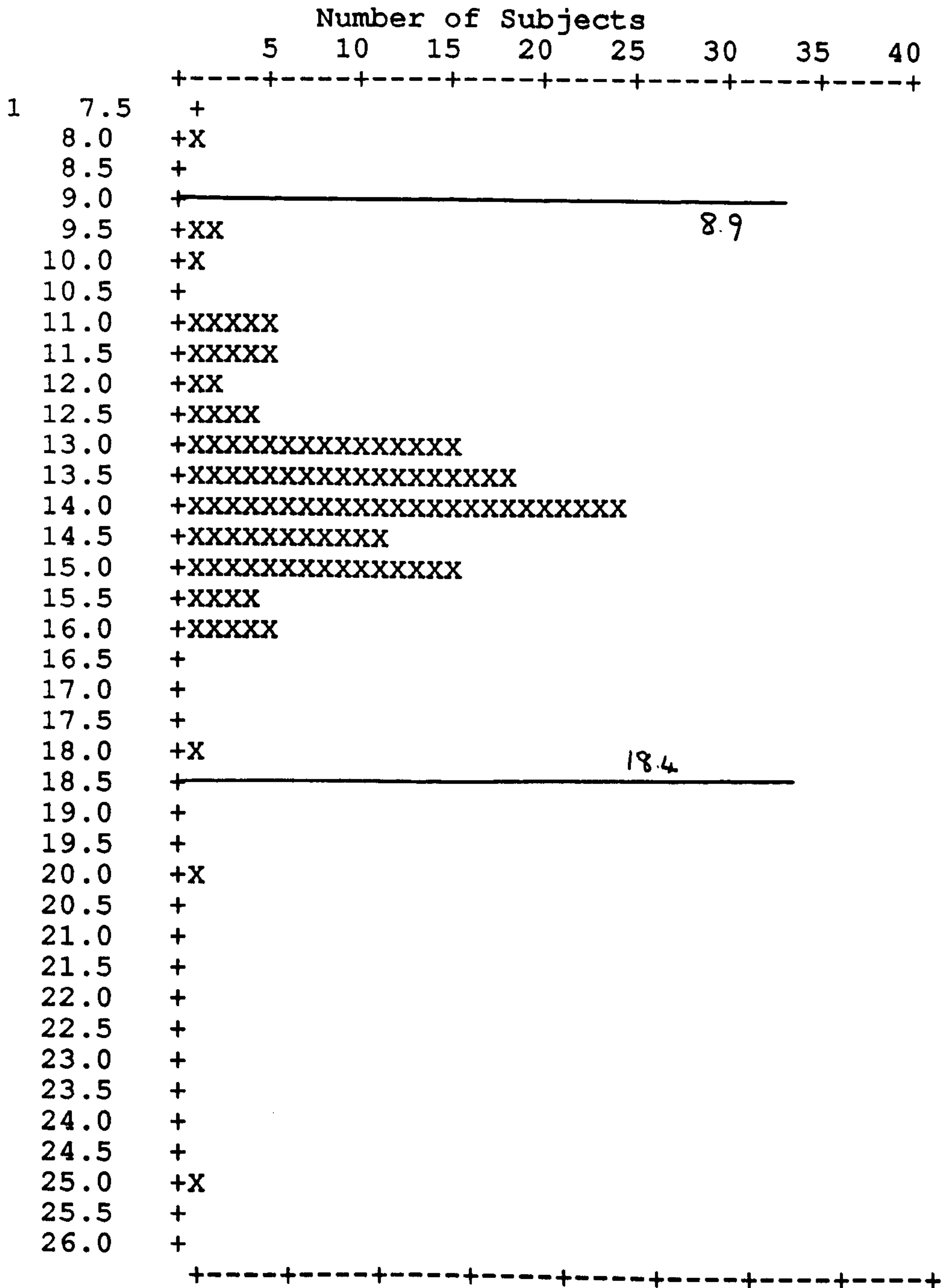

Distribution of AVAUDIO values for n=115

Mean=9.7, S.D.=4.0

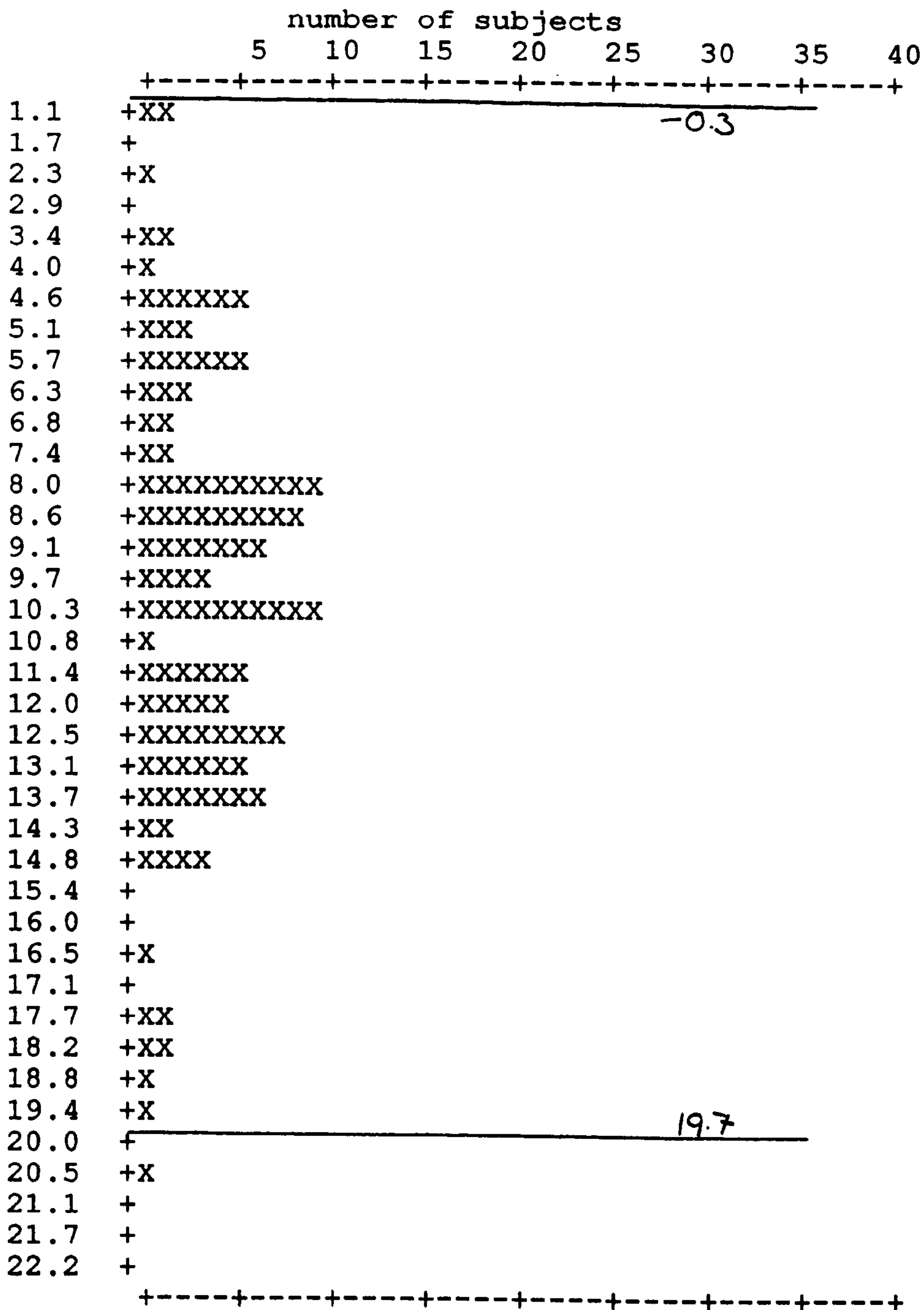

Distribution of values for the mid-frequency notch
condition masked threshold for n=115

Mean=58.6, S.D.=5.0

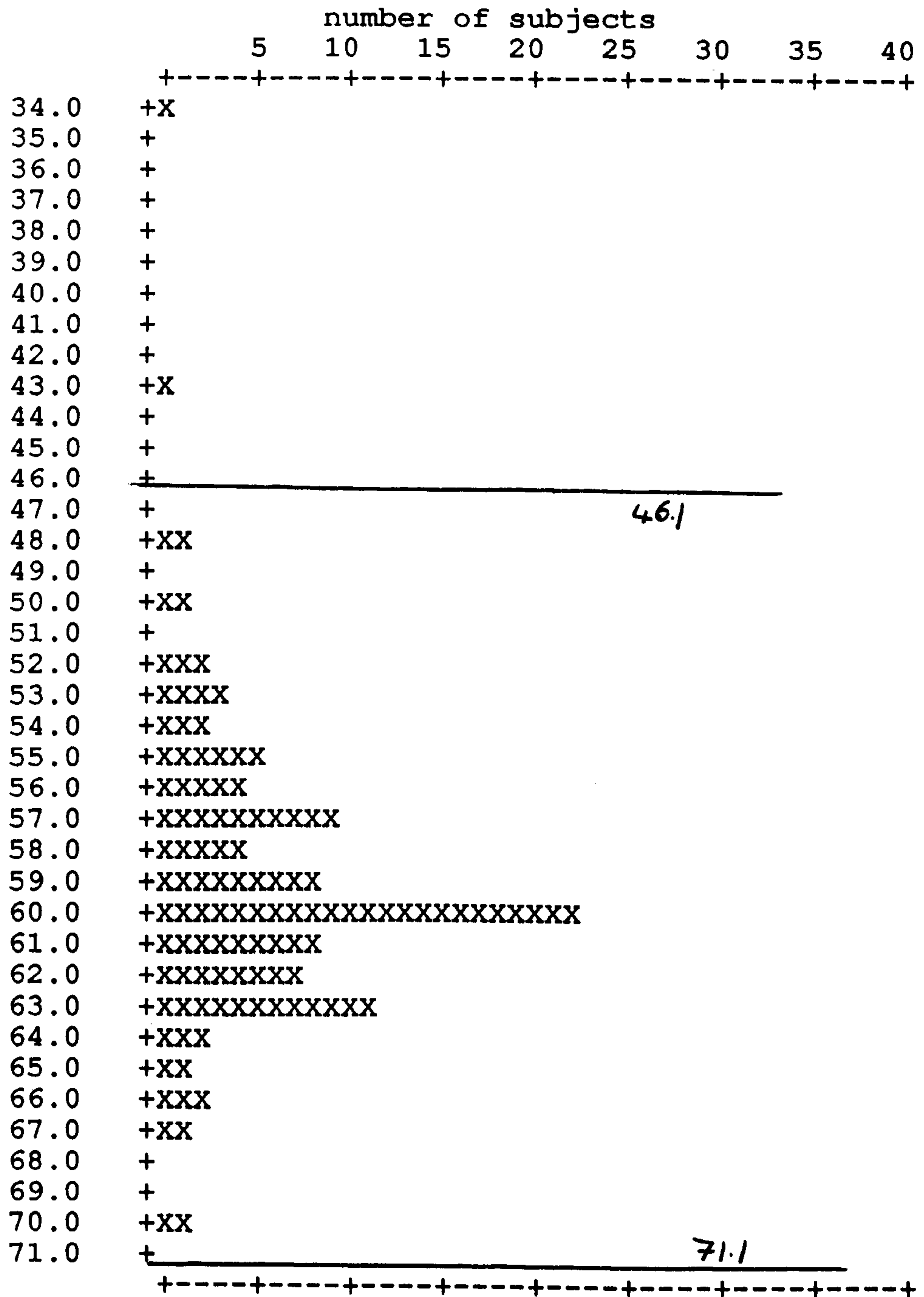

Distribution of values for the mid-frequency no-notch condition masked threshold for n=115

Mean=31.1, S.D.=2.1

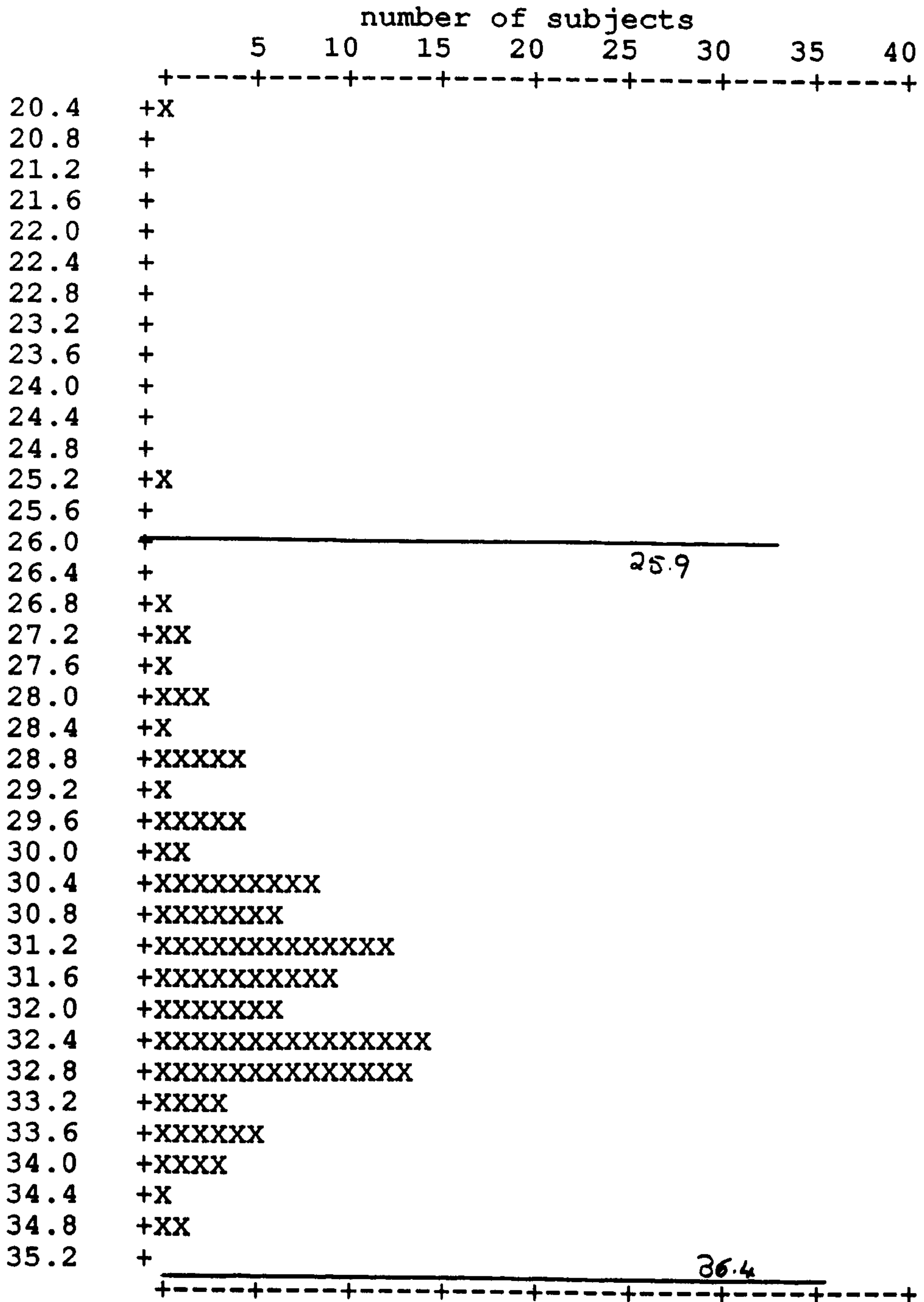

Distribution of values for the low-frequency (1)
condition masked threshold for n=115

Mean=22.1, S.D.=2.4

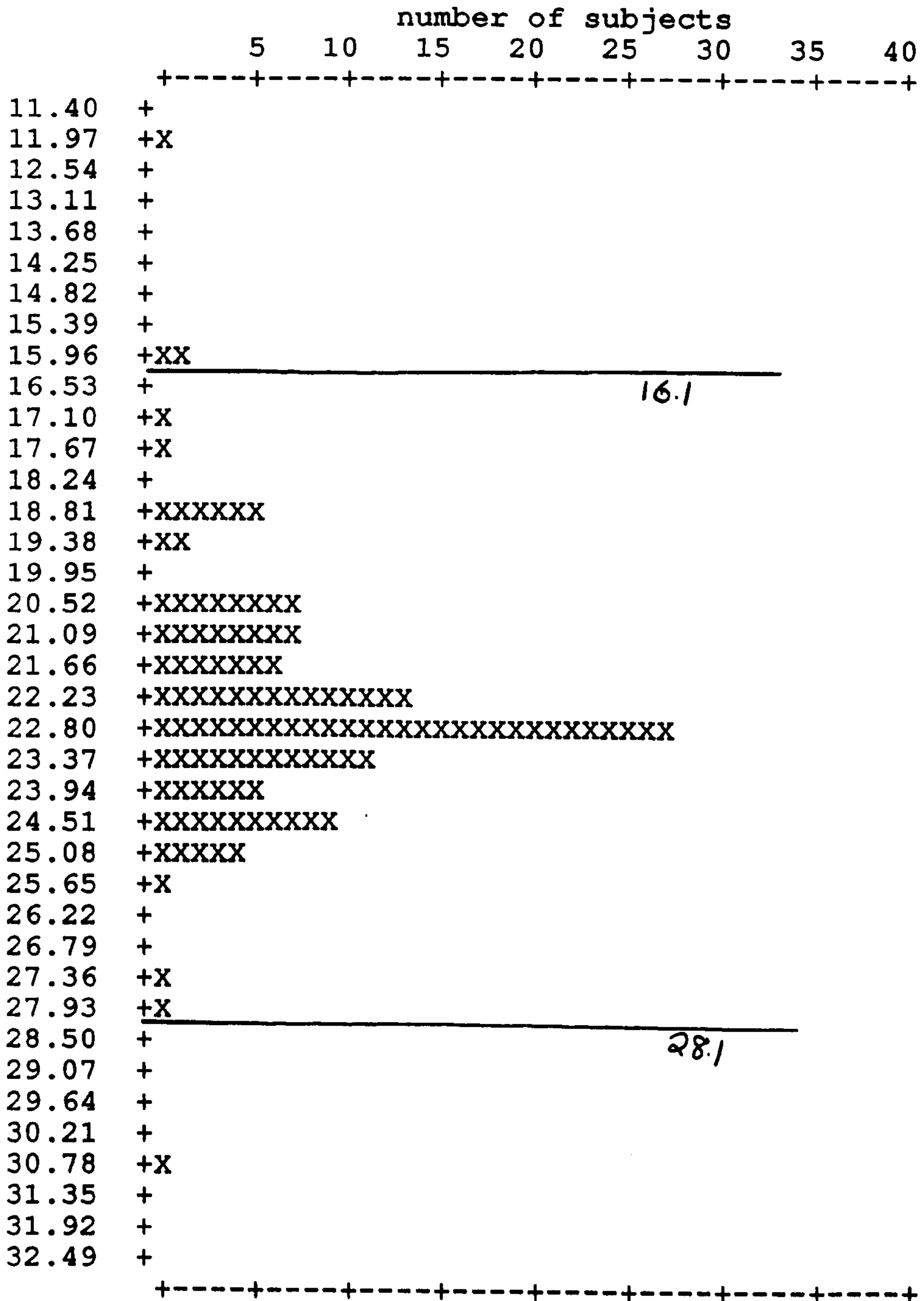

Distribution of values for the low-frequency (2)
condition masked threshold for n=115

Mean=34.6, S.D.=3.1

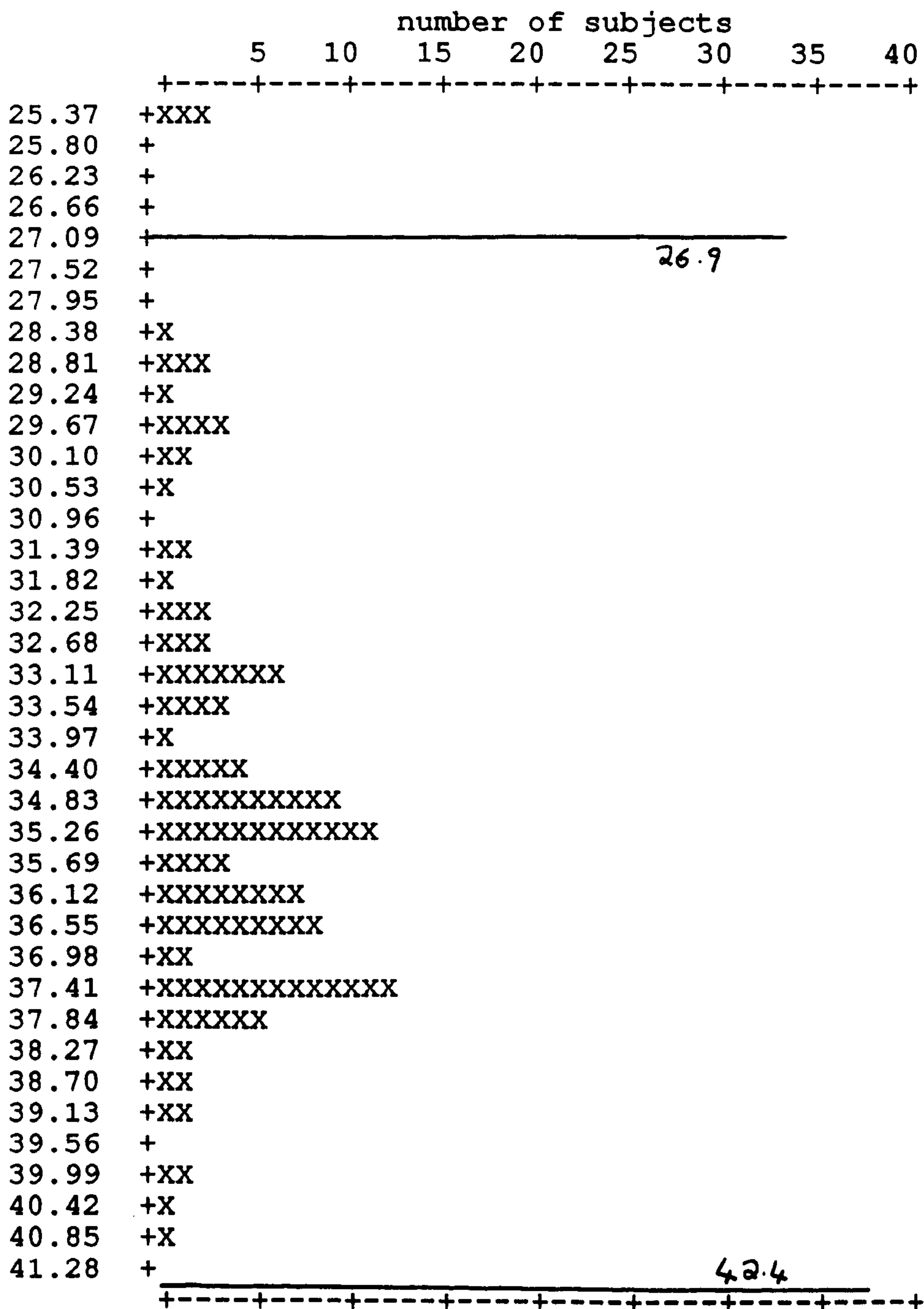

Distribution of values for BMLDs n=115

Mean=12.5, S.D.=2.2

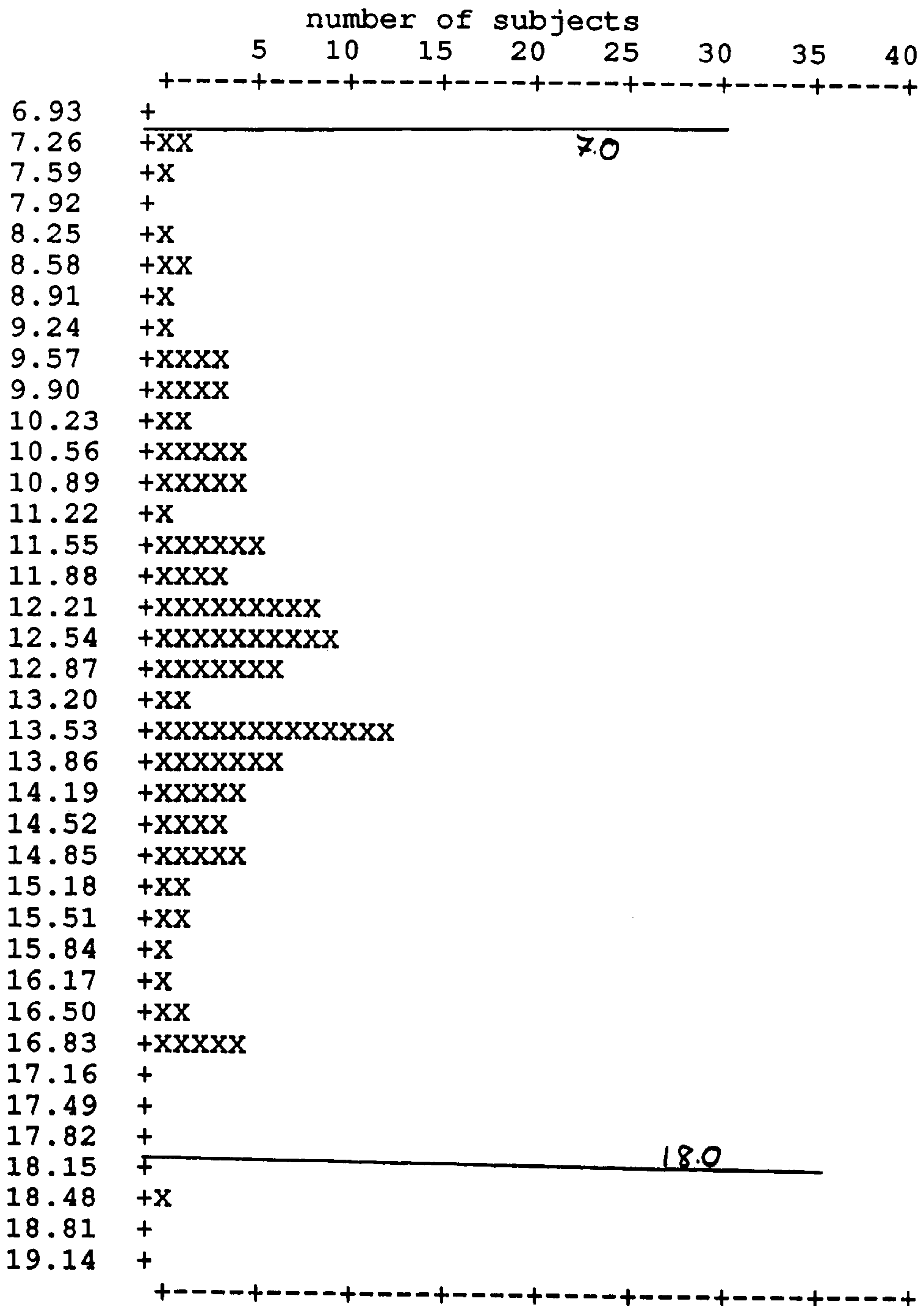

Distribution of scores on the Divided Attention Condition of the Dichotic Listening Test (n=115)

Mean=70.0, S.D.=12.2

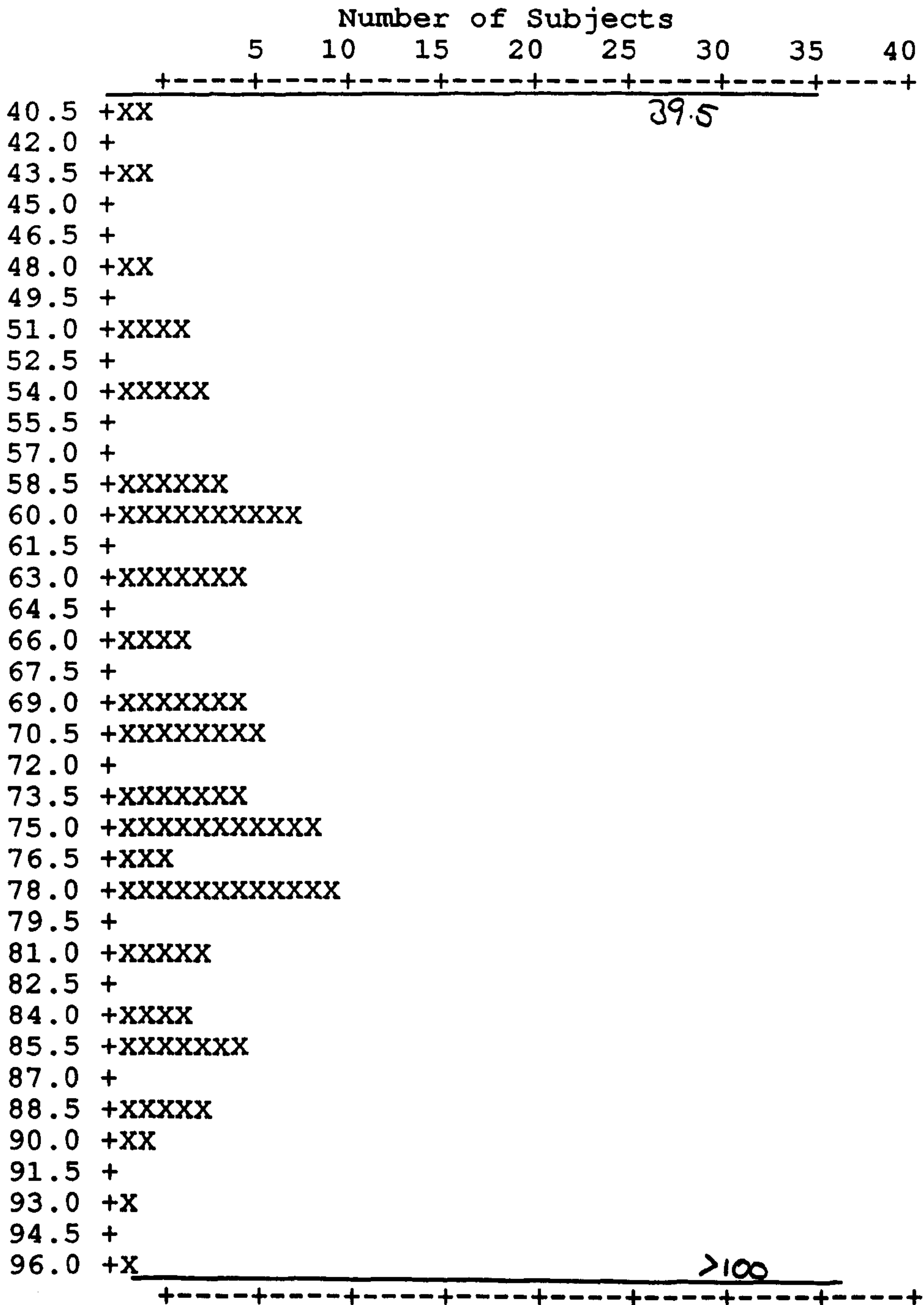

Distribution of scores on the Focussed Attention condition of the Dichotic Listening Test (n=115)

Mean=87.9, S.D.=8.5

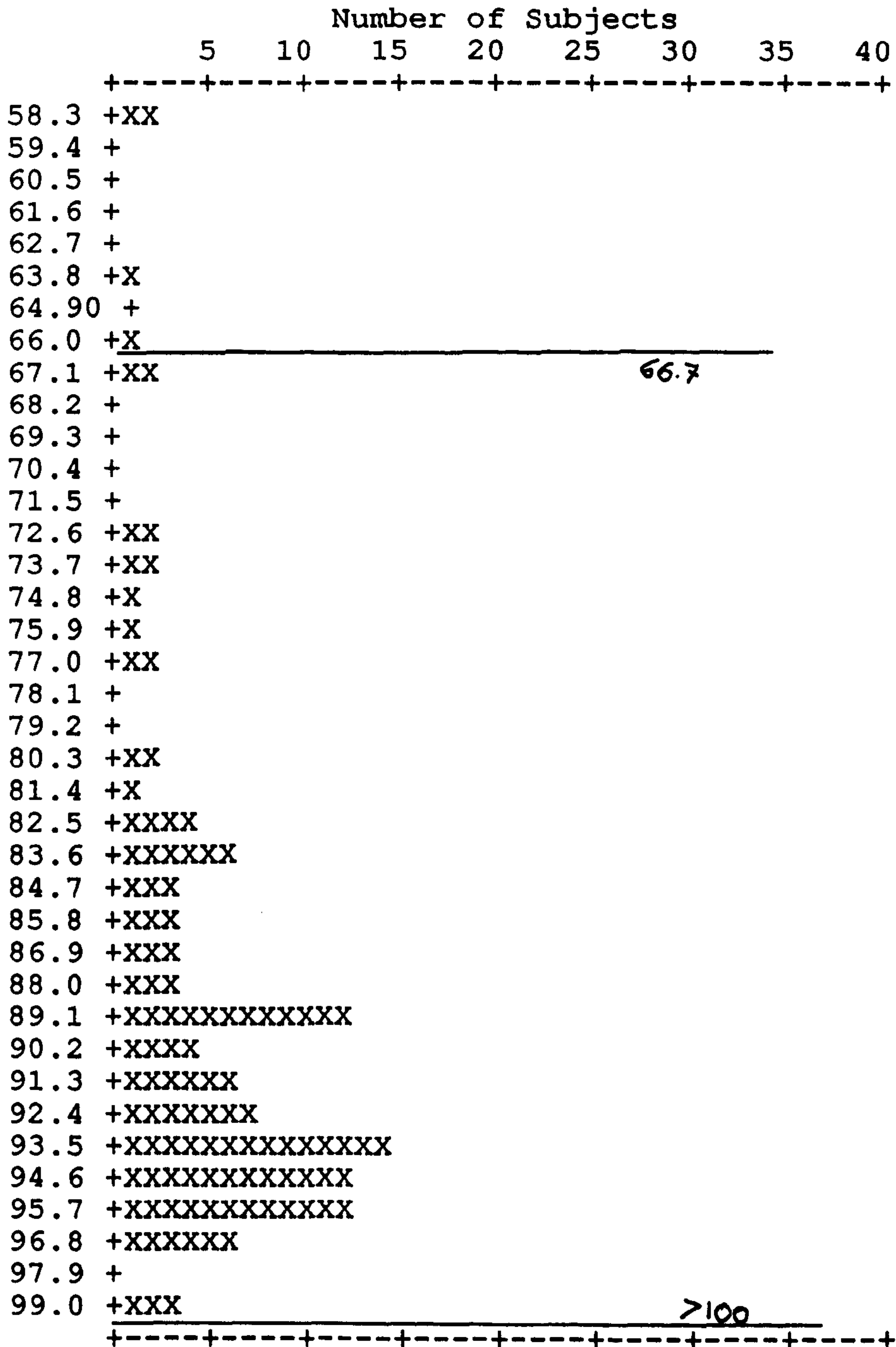

Distribution of reaction times on the Sentence Monitoring Task (predictable, unpredictable and nonsense conditions combined) n=100

Mean=0.5, S.D.=0.2

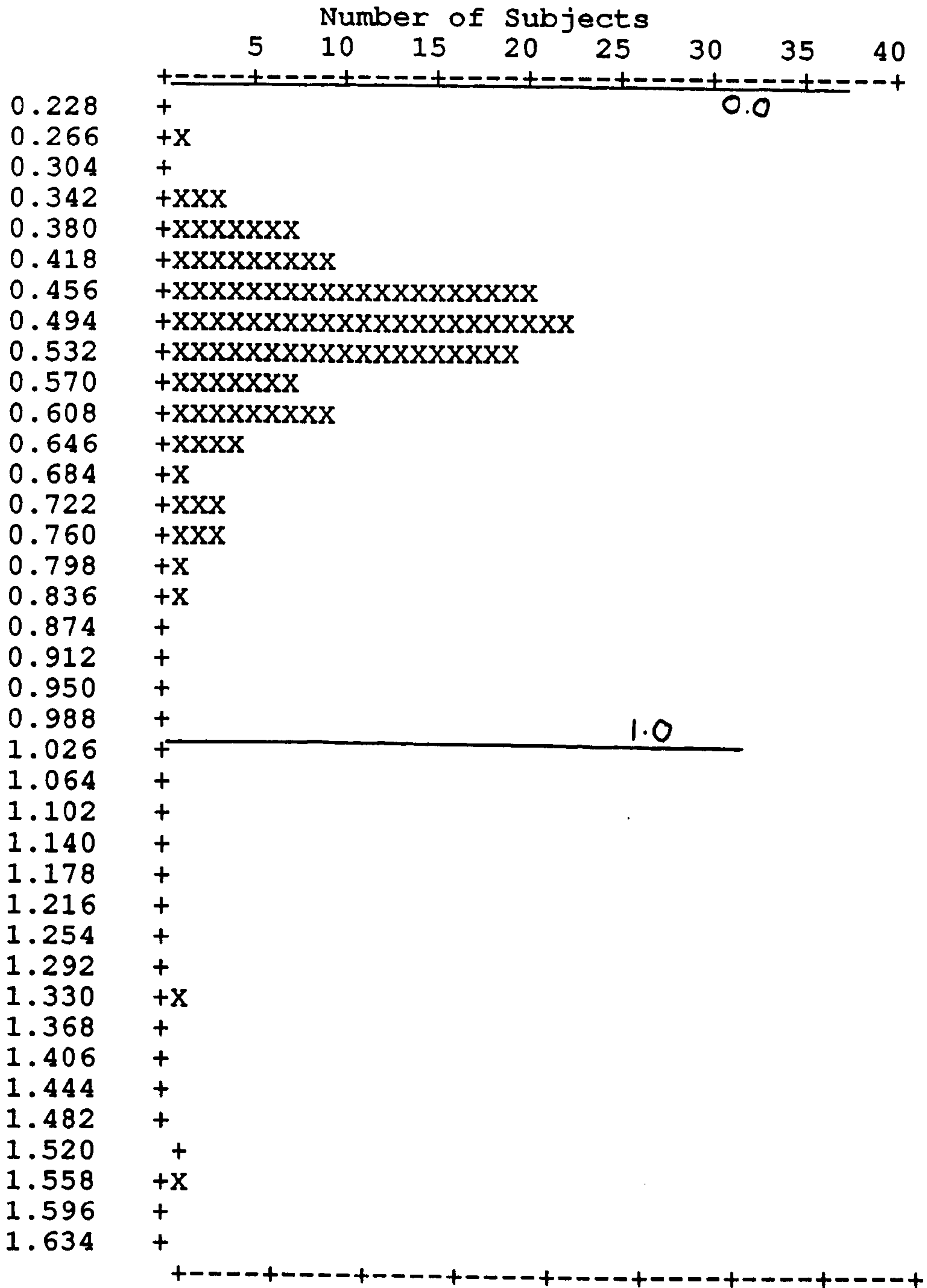

Distribution of scores on the Lipreading Test
(n=115)

Mean=5.8, S.D.=2.8

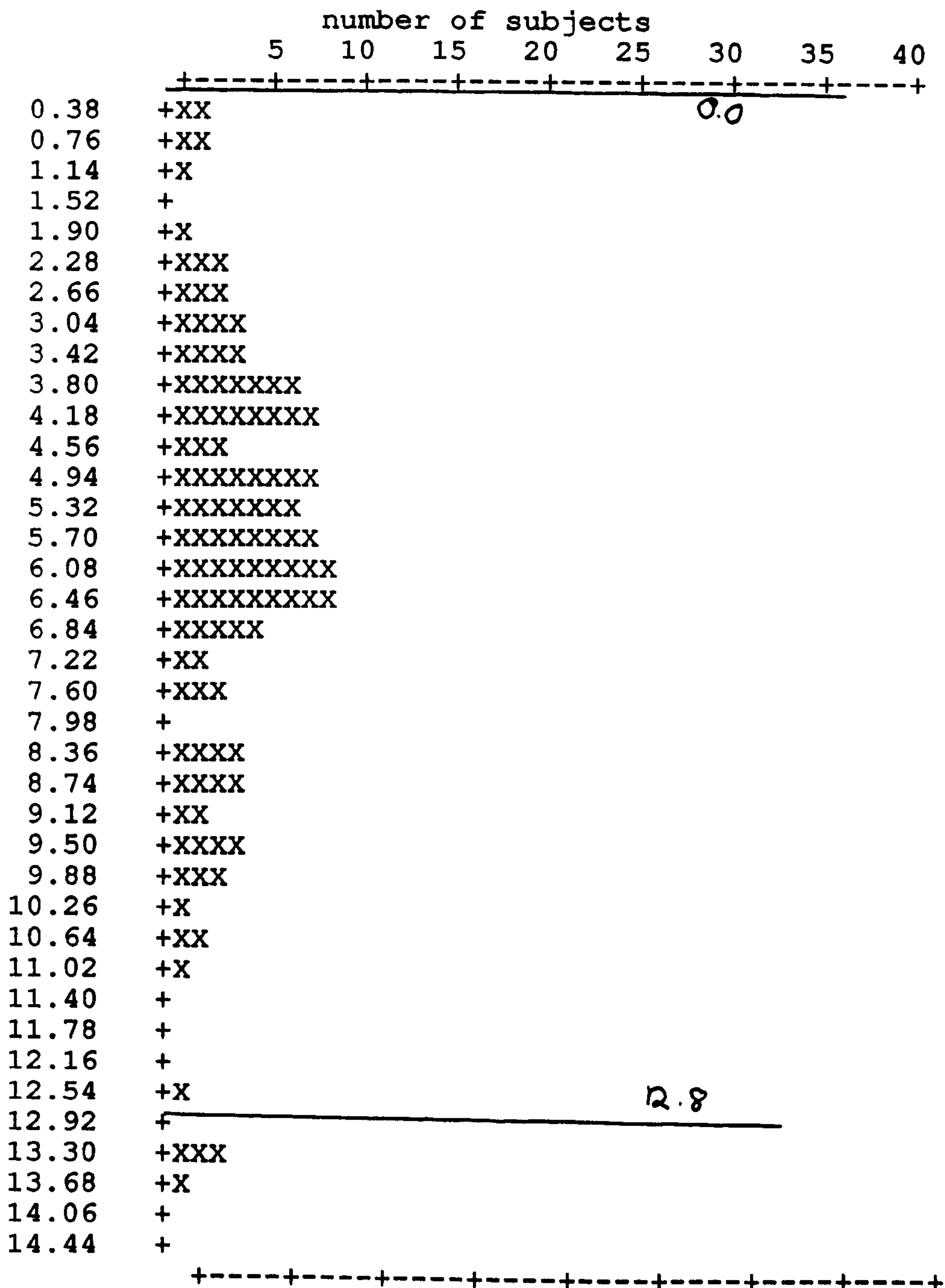

Distribution of scores on the combined anxiety scale of the Crown-Crisp Questionnaire n=115

Mean=4.3, S.D.=2.4

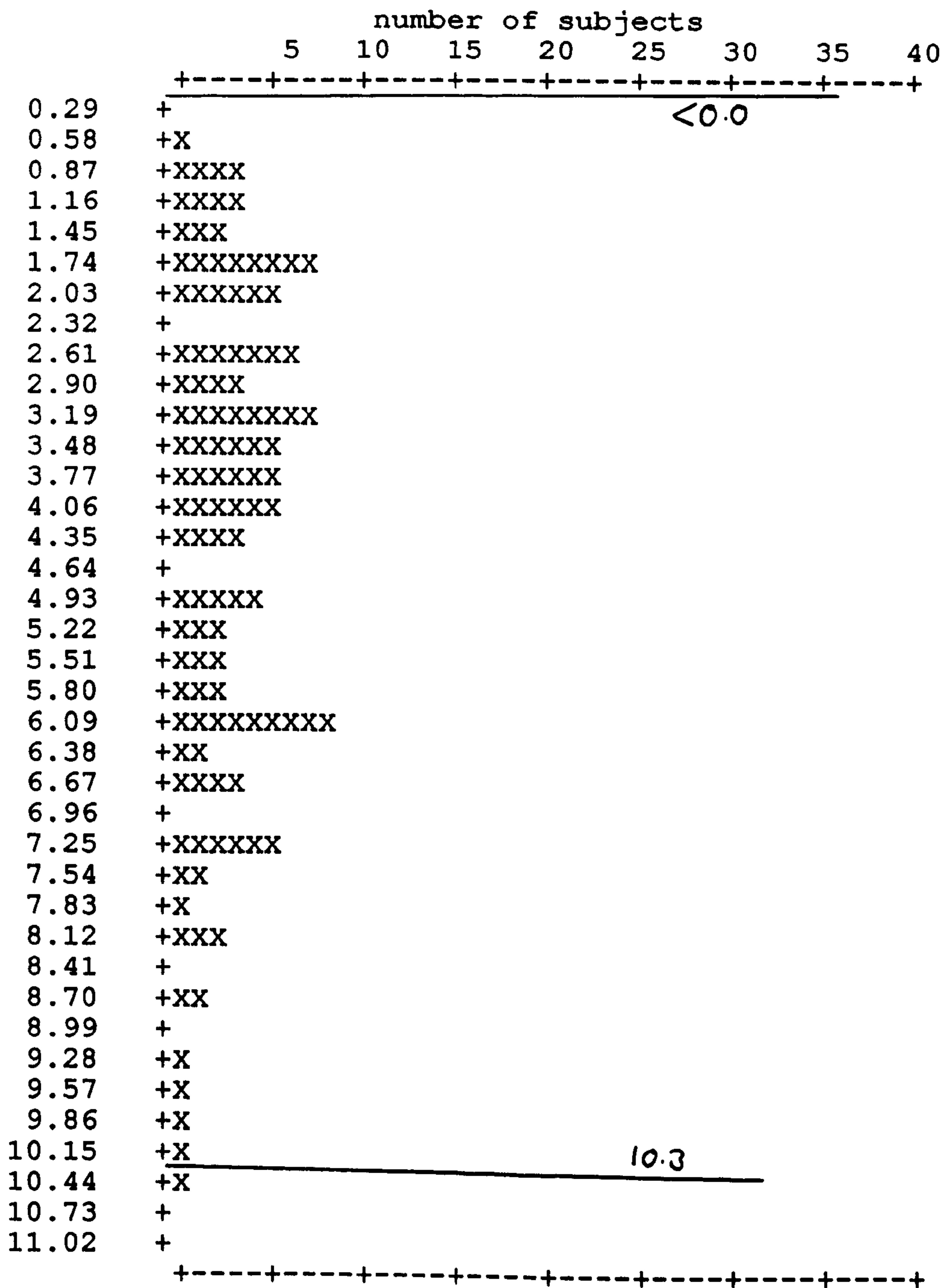

Distribution of scores on the FAAF Test n=104

Mean=75.4, S.D.=6.8

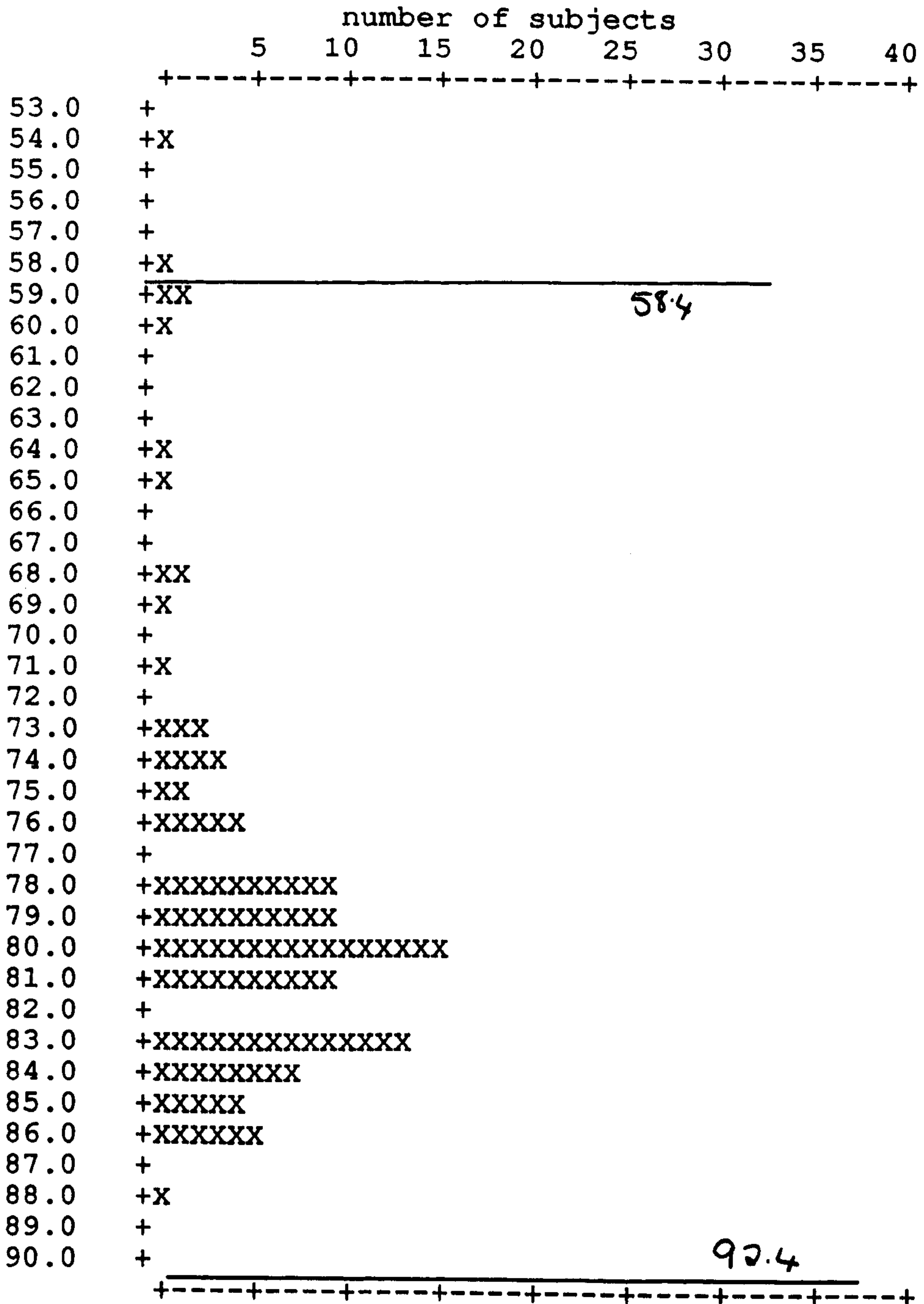

BIBLIOGRAPHY

Alberti, P.W. (1987) Noise and the Ear. In: Kerr, A.G (Ed). *Scott-Brown's Otolaryngology*. 5th Edition Volume 2 - Adult Otolaryngology. Butterworths, London, pp594-642

Allen, W.M. & Masters, W.H. (1955) Traumatic laceration of uterine support. *American Journal of Obstetrics and Gynaecology* 70, 500 - 513

Anderson, S.D. & Kemp, D.T. (1979) The evoked cochlear mechanical response in laboratory primates. *Archives of Oto-Rhino-Laryngology* 224, 47-54

Aniansson, G. (1974) Methods for assessing high-frequency hearing loss in everyday listening situations. *Acta-oto-laryngology Supplement* , 139

Bamford, J. & Saunders, E. (1985) Central Auditory Dysfunction. In: Crystal, D. & Cooper, J (Eds). *Hearing impairment, auditory perception and language disability*. Edward Arnold, London, pp230-245

Bamford J, Wilson I. (1979) Methodological considerations and practical aspects of the BKB Sentence Lists. In: Bamford J, Bench J, (Eds). *Speech-hearing tests and the spoken language of hearing-impaired children*. Academic Press, London, pp179-187

Beard, R.W., Belsey, E.M., Lieberman, B.A. & Wilkinson, J.C.M. (1977) Pelvic pain in women. *American Journal of Obstetrics and Gynaecology* 128, 566 - 570

Bench, J. & Bamford, J. (1979) *Speech-hearing tests and the spoken language of hearing-impaired children*. Academic Press, London

Berkhout (1984) Why do referral rates vary? Some theoretical considerations on the study of medical practice. Working Paper 391, School of Geography, University of Leeds

Blumenfeld, V.G., Bergman, M. & Millner, E. (1968) Speech discrimination in an aging population. Journal of Speech and Hearing Research 11, 211-217

Botwinick, J. (1966) Cautiousness in advanced age. Journal of Gerontology 12, 347-353

British Society of Audiology (1981) Recommended procedures for pure tone British Journal of Audiology 15, 213-216

British Society of Audiology (1988) Descriptors for pure-tone audiograms. British Journal of Audiology 22, 123

Bronkhorst, A.W. & Plomp, R. (1988) The effect of head-induced interaural time and level differences on speech intelligibility in noise. Journal of the Acoustical Society of America 83 (4), 1508-1516

Brooks, D.N. (1976) Counselling and its effects on hearing aid use. Scandinavian Audiology 6, 101-107

Bucquet, D. & Curtis, S. (1986) Socio-demographic variation in perceived illness and the use of primary care: the value of community survey data for primary care service planning. Social Science and Medicine 23, 737-744

Butler, K.G. (1983) Language Processing- Selective Attention and Mnemonic Strategies. In: Lasky, E.Z. &

Katz, J. (Eds). *Central Auditory Processing Disorders - Problems of Speech, Language and Learning*. University Park Press, Maryland, pp297-315

Byrne, J.E.T. & Kerr, A.G. (1987) Sensorineural Hearing Loss. In: Kerr, A.G. (Ed). *Scott-Brown's Otolaryngology*. 5th Edition, Volume 3. Butterworths, London, pp383-384

Castelnuovo-Tedesco, P. & Krout, B.M. (1970) Psychosomatic aspects of chronic pain. *Psychiatry in Medicine* 1, 109 - 126

Cope, Y & Lutman, M.E. (1988) Oto-acoustic Emissions. In: McCormick, B. (Ed). *Paediatric Audiology 0-5 Years*. Taylor & Frances, London, pp221-246

Crombie, D. cited in Bucquet & Curtis (1986)

Crown, S. & Crisp, A.H. (1966) A short clinical diagnostic self-rating scale for psychoneurotic patients - The Middlesex Hospital Questionnaire. *British Journal of Psychology* 112, 917-923

Cunningham, D.R., Cunningham, C.A. & Vise, L.K. (1987) The effects of chronic hypoxia on central auditory processing in patients with chronic obstructive pulmonary disease. *Ear and Hearing* 6 (6), 297-303

Darwin, C.J. & Baddeley, A.D. (1974) Acoustic memory and the perception of speech. *Cognitive Psychology* 6, 41-60

Davis, A.C. (1983a) Hearing disorders in the population: first phase findings of the MRC National Study of Hearing. In: Lutman, M.E. & Haggard, M.P. (Eds) *Hearing Science and Hearing Disorders*. Academic press, London,

pp35-60

Davis, A.C. (1983b) Effects of noise and socioeconomic factors on hearing impairment. In: Rossi, G. (Ed). *Noise as a Public Health Problem*. Volume 1. Centro Ricerche e Studi Amplifon, Milan, pp201-211

Demorest, M.E. & Walden, B.E. (1984) Psychometric principles in the selection, interpretation and evaluation of communication self-assessment inventories. *Journal of Speech and Hearing Research* 49, 226-240

Dengerink, J.E., Dengerink, H.A. & Chermack, G.D. (1982) Personality and vascular responses as predictors of temporary threshold shifts after noise exposure. *Ear and Hearing* 34, 196-201

Dreschler, W.A. (1983) Relations between psychophysical data and speech perception for hearing-impaired subjects. University of Amsterdam

Dreschler, W.A. & Plomp, R. (1980) Relations between psychophysical data and speech perception for hearing impaired subjects I. *Journal of the Acoustical Society of America* 65, 1608-1615

Dubno, J.R., Dirks, D.D. & Morgan, D.E. (1984) Effects of age and mild hearing loss on speech recognition in noise. *Journal of the Acoustical Society of America* 76 (1), 87-96

Earl, P., Lipscomb, D.M., Diefendorf, A.O., & Schmidhammer, J. (1987) Auditory dysfunction in subjects with normal hearing. American Speech and Hearing Association, November New Orleans.

Editorial (1978) Enigmatic Pelvis Pain. British Medical Journal 2, 1041-1042

Efron, R., Yund E.W., Nichols, D. & Crandall, P.H. (1983) An ear asymmetry for gap detection following anterior temporal lobectomy. Neuropsychologia 23, 43-50

Elliot, D.N., Riach, W.D., Sheposh, J.D. & Trahotis, C. (1966) Discrimination of high school sophomores on a battery of auditory tests. Acta-oto-laryngology Suppl. 216

Era, P., Jokela, J., Qvarnberg, Y. & Heikkinen, E. (1986) Pure tone thresholds, speech understanding and their correlates in samples of men of different ages. Audiology 25, 338-352

Erber, N.P. (1975) Auditory-visual perception of speech. Journal of Speech and Hearing Disorders 40, 481-492

Evans, E.F. (1975) Normal and abnormal functioning of the cochlear nerve. Symposium of the Zoological Society of London 37, 133-165

Festen, J.M. & Plomp, R. (1981) Relations between auditory functions in normal hearing. Journal of the Acoustical Society of America 70 (2), 356-369

Festen, J.M. & Plomp, R. (1983) Relations between auditory functions in impaired hearing. Journal of the Acoustical Society of America 73 (2), 652-662

Fitzgibbins, P.J. & Wightman, F.L. (1982) Gap detection in normal and hearing-impaired listeners. Journal of the Acoustical Society of America 72, 761-765

Foster, J.R. & Haggard, M.P. (1979) FAAF - An efficient analytical test of speech perception. Proceedings of the Institute of Acoustics pp9-12, paper 1A3

Foster, J.R. & Haggard, M.P. (1984) Introduction and test manual for FAAF II The Four Alternative Auditory Feature Test (Mark II). IHR Internal Report Series B, No 11, MRC Institute of Hearing Research

Fowler, E.P. Jr & Zeckel, A. (1952) Psychosomatic aspects of Meniere's disease. Journal of the American Medical Association 148, 1265-1268

Fowler, E.P. Jr & Zeckel, A. (1953) Psychophysiological factors in Meniere's disease. Journal of the American Medical Association 150, 127-129

Garnes & Bond (1976) The relationship between semantic expectation and acoustic information. Phonologica, 285-293

Gatehouse, S. (1988) A pseudo-free-field measure of auditory disability. Submitted to the British Journal of Audiology

Geer, S.E., Gleitman, H. & Gleitman, L. (1972) Paraphrasing and remembering compound words. Journal of Verbal Learning and Verbal Behaviour 11, 348-355

Gelfand, S.A. (1981) *Hearing - An Introduction to Psychological and Physiological Acoustics*. Dekker Inc., New York, pp239-258

Gilholm Herbst, K. & Humphrey, C. (1980) Hearing impairment and mental state in the elderly living at

home. British Medical Journal 281, 903-905.

Giolas, T.G., Owens, E., Lamb, S.L. & Schubert, E.D. (1979) Hearing performance inventory. Journal of Speech and Hearing Disorders 29, 215-230

Gochman, D.S. & Saucier, J.F. (1982) Perceived vulnerability in children and adolescents. Health Education Quarterly 9, 142-155

Gottlieb, M.I., Zinkus, P.W. & Thompson, A. (1979) Chronic middle ear disease and auditory perceptual deficits. Clinical Paediatrics 18 (12), 725-730

Granick, S., Kleban, M.H. & Weiss, A.D. (1976) Relationships between hearing loss and cognition in normally-hearing aged persons. Journal of Gerontology 31, 434-440

Hagerman, B. (1984) Clinical measurements of reception threshold in noise. Scandinavian Audiology 13 (1), 57-63

Haggard, M.P., Foster, J.R., Lutman, M.E. & Saunders, G.H. (1988) FAAF segmental errors are sensitive to minor imperfections of auditory communication. Submitted to British Journal of Audiology

Haggard & Hughes (1988) Objectives, values and methods of screening children's hearing - A review of the literature. IHR Internal Reports Series A, No. 4

Haggard, M.P., Lindblad, A.C. & Foster, J.R. (1986) Psychoacoustic and audiometric prediction of auditory disability for different frequency responses at listener adjusted presentation levels. Audiology 25, 277-298

- Haggard, M.P., Saunders, G.H. & Gatehouse, S. (1987) Correlations among auditory functions in the 'normal range'. Journal of the Acoustical Society of America 82, (S 1) S 4, ASA meeting, November, Miami
- Hall, J.W., Tyler, R.S. & Fernandes, M.A. (1984) Factors influencing the MLD in cochlear hearing-impaired and normal-hearing listeners. Journal of Speech and Hearing Research 27, 145-154
- Harrison, R.V., Aran, J.M. & Err, J.P. (1981) AP tuning curves from normal and pathological human and guinea-pig cochleas. Journal of the Acoustical Society 69, 1374-1385
- High, W.S., Fairbanks, G. & Glorig A. (1964) Scale for self-assessment of hearing handicap. Journal of Speech and Hearing Disorders 19, 215-230
- Hinchcliffe, R. (1965) A psychophysiological investigation into vertigo. Unpublished Ph.D. thesis. University of London
- Hinchcliffe, R. (1967) An attempt to classify the primary vertigos. Journal of Laryngology and Otology 81, 849-859
- Hirsch, I.J. (1948) Influence of interaural phase on interaural summation and inhibition. Journal of the Acoustical Society of America 20, 536-544
- Horowitz, F. & Leake, H. (1980) Effects of chronic otitis media on cognitive development. Annals of Otology, Rhinology and Laryngology 89 (suppl. 68), 264-268
- Houtgast, T. (1977) Auditory-filter characteristics derived from direct-masking data and pulsation-threshold

data with a rippled-noise masker. *Journal of the Acoustical Society of America* 62, 409-415

Hunt, S., McEwen, J. & McKenna, S. (1985) Social inequalities and perceived health. *Effective Health Care* 2, 151-160

Hunt, S., McKenna, S., McEwen, J. & Pappe, E. (1981) The Nottingham health profile, subjective health status and medical consultations. *Social Science and Medicine* 15a, 221-229

Ickes, W.K. & Nader, C. (1982) Noise-induced hearing loss and stress-prone behaviour. *Ear and Hearing* 34, 191-195

Jakes, S. (1987) Psychological aspects of disorders of hearing and balance pp415-445. In: Kerr, A.G. (Ed). *Scott-Brown's Otolaryngology* 5th Edition, Volume 2 - Adult Otology. Butterworths, London, pp415-445

Janz, N.K. & Becker, M.H. (1984) The Health-Belief model: A decade later. *Health Education Quarterly* 11 (1), 1-47

Jeffcoate, T.N.A. (1975) *Principles of Gynaecology*. 4th Edition, Butterworths, London.

Jeffers, J. & Barley, M. (1971) *Speechreading (Lipreading)*. Thomas, Springfield

Johnston, W.A. & Wilson, J. (1980) Perceptual processing of nontargets in an attentional task. *Memory and Cognition* 8, 372-377

Jones, D.A., Victor, C.R. & Vetter, N.J. (1984) Hearing difficulty and its psychological implications for the

elderly. *Journal of Epidemiology and Community Health* 38, 75-58

Kahneman, D. (1973) *Attention and Effort*. Prentice-Hall, New Jersey

Kemp, D.T. (1978) Stimulates acoustic emissions from within the human auditory system. *Journal of the Acoustical Society of America* 64, 1386-1391

Kemp, D.T. (1986) Otoacoustic emissions, travelling waves and cochlear mechanisms. *Hearing Research* 22, 95-104

Kimura, D. (1961) Cerebral dominance and the perception of verbal stimuli. *Canadian Journal of Psychology* 15, 166-171

Kinsbourne, M. (1973) The control of attention by interaction between the cerebral hemispheres. In: Kornblum (Ed). *Attention and Performance*. Volume IV, Academic Press, New York, pp345-362

Kristiansen, C.M. (1985) Value correlates of preventive health behaviour. *Journal of Personality and Social Psychology* 49 (3), 748-758

Lackner, J.R. & Teuber, H-L. (1973) Alterations in auditory fusion thresholds after cerebral injury in man. *Neuropsychologia* 11, 409-416

Laurence, R.F., Moore, B.C.J. & Glasberg, B.R. (1983) A comparison of behind-the-ear high-fidelity hearing aids and 2-channel compression aids in the laboratory and in everyday life. *British Journal of Audiology* 17, 31-48

Levitt, H. (1971) Transformed up-down methods in psychoacoustics. *Journal of the Acoustical Society of America* 49, 467-477

Liberman, M.C. & Beil, D.G. (1979) Hair cell condition and auditory nerve response in normal and noise-damaged cochleas. *Acta Oto-laryngologica* 88, 161-176

Liberman, M.C. & Mulroy, M.J. (1982) Acute and chronic effects of acoustic trauma: cochlear pathology and auditory nerve pathophysiology. In: Hamernik, R.P., Henderson, D. & Salvi, R (Eds). *New Perspectives on Noise Induced hearing Loss*. Raven Press, New York, pp105-135

Licklider, J.C.R. (1948) The influence of interaural phase relations upon the masking of speech by white noise. *Journal of the Acoustical Society of America* 49, 150-159

Lubert, N. (1981) Auditory perceptual impairment in children with specific language disorders. A review of the literature. *Journal of Speech and Hearing Research* 46, 3-9

Lutman, M.E. (1983) Frequency resolution, auditory disability and handicap. *Journal of the Acoustical Society of America Supplement* 1, C7, S7. ASA meeting Connecticut

Lutman, M.E. (1987) Speech tests in quiet and in noise as measures of auditory processing. In: Martin, M.C. (Ed). *Speech Audiometry*. Taylor Francis, London, pp63-74

Lutman, M.E., Brown, E.J. & Coles, R.R.A. (1987) Self-reported disability and handicap in the population in

relation to pure-tone threshold, age, sex and type of hearing loss. *British Journal of Audiology* 21, 45-58

Lutman, M.E. & Clark, J. (1986) Speech identification under simulated hearing-aid frequency response characteristics in relation to sensitivity, frequency resolution and temporal resolution. *Journal of the Acoustical Society of America* 80 (4), 1030-1040

Lutman, M.E. & Flemming, A.J. (1988) Presence of click-evoked otoacoustic emissions in adults with varying degrees of hearing impairment. Presented at the 19th International Congress of Audiology, Jerusalem, June

Lutman, M.E. & Wood, E.J. (1985) A simple clinical measure of frequency resolution. *British Journal of Audiology* 19, 1-8

Lyregaard, P. E. (1982) Frequency selectivity and speech intelligibility in noise. *Scandinavian Audiology suppl.* 15, 113-122

McCormick, B. (1979) Audio-visual discrimination of speech. *Clinical Otolaryngology* 4, 335-361

McLeod, A.S. (1988) Effective methods for measuring lipreading skills. Unpublished Ph.D. thesis, University of Nottingham

McLeod, A.S. & Summerfield, A.Q. (1987) Quantifying the contribution of vision to speech intelligibility in noise. *British Journal of Audiology* 21, 131-141

Marcus-Bernstein, C. (1986) Audiologic and non-audiologic correlates of hearing handicap in black elderly. *Journal*

of Speech and Hearing Research 29, 301-312

Marslen-Wilson, W.D. (1973) Linguistic structure and speech shadowing at very short latencies. *Nature* 244, 522-523

Marslen-Wilson, W.D. (1975) Sentence perception as an interactive parallel processing. *Science* 189, 226-228

Marslen-Wilson, W.D. & Tyler, L.K. (1975) Processing structure of sentence perception. *Nature* 257, 784-786

Marslen-Wilson, W.D. & Tyler, L.K. (1980) The processing structure of spoken language understanding. *Cognition* 8, 1-71

Mechanic, D. (1980) The experience and reporting of common physical complaints. *Journal of Health and Social Behaviour* 21, 146-155

Merluzzi, F. & Hinchcliffe, R. (1973) Threshold of subjective auditory handicap. *Audiology* 12, 65-69

Miller, J.L., Green, K. & Schermer, T.M. (1984) A distinction between the effects of sequential speaking rate and semantic congruity on word identification. *Perception and Psychophysics* 36 (4), 329-337

Moore, B.C.J. (1977) *Psychology of Hearing*. Cambridge Press, Cambridge

Moore, B.C.J. (1978) Psychophysical Tuning Curves measured in simultaneous and forward masking. *Journal of the Acoustical Society of America* 63, 524-532

- Moore, B.C.J. (1985) Frequency selectivity and temporal resolution in normal and hearing impaired listeners. *British Journal of Audiology* 19, 189-201
- Moore, J.T. & Whanger, A.D. (1983) Functional Psychiatric Disorder. In: Cape, R.D.T., Coe, R.M. & Rossman, I. (Eds). *Fundamentals of Geriatric Medicine*. Raven Press, New York, pp129-131
- Morton, J., Marcus, S. & Frankish, C. (1976) Perceptual Centers (P-centers). *Perception and Psychophysics* 83, 405-408
- Murphy, R.T. (1973) *Investigations of a Creativity Dimension*, Educational Testing Service, New Jersey, RB-73-12
- Narula, A.A., & Mason, S.M. (1988) Selective dysacusis - a preliminary report. *Journal of the Royal Society of Medicine* 81, 338-340
- Noble, W.G. (1978) *Assessment of impaired hearing*. New York, Academic Press
- Noble, W.G. (1979) *Test Manual for the Hearing Measurement Scale*. University of New England, Armidale.
- Noble, W.G. & Atherley, G.R.C. (1970) The hearing handicap measurement scale: a questionnaire for the assessment of auditory disability. *Journal of Auditory Research* 10, 229-250
- Norris, M.L. & Cunningham, D.R. (1981) Social input of hearing loss in the aged. *Journal of Gerontology* 36, 727-729

Office of Population Census and Surveys (1979). Morbidity Statistics from General Practice 1971-1972. Second National Study OPCS, HMSO, London

Olsen, W.O., Noffsinger, D. & Carhart, R. (1976) Masking level differences encountered in clinical populations. *Audiology* 15, 287-301

Parving, A. & Ostri, B. (1983) On objective criteria for hearing impairment and disability. *Scandinavian Audiology* 12, 165-169

Parving, A., Ostri, B., Katholm, M. & Parbo, J. (1986) On prediction of hearing disability. *Audiology* 25, 129-135

Patterson, R.D. (1976) Auditory filter shapes derived with noise stimuli. *Journal of the Acoustical Society of America* 59 (3), 640-654

Patterson, R.D., Nimmo-Smith, I., Weber, D.L. & Milroy, R. (1982) The deterioration of hearing with age: frequency selectivity, the critical ratio, the audiogram, and speech threshold. *Journal of the Acoustical Society of America* 72 (6), 1788-1803

Pearce, J.L. & Coles, R.R.A (1980) A contextual analysis of BKB (st) sentence lists. *Australian Journal of Audiology* 2, 63-69

Pick, G. & Evans, E. (1983) Dissociation between frequency resolution and hearing threshold. In: Klinke, R. & Hartman (Eds). *Hearing - Physiological Bases and Psychophysics*. Springer Verlag, New York, pp393-399

Plomp, R. & Mimpen, A.M. (1979) Improving the reliability

of the SRT for sentences. *Audiology* 18, 43-52

Probst, R., Lonsbury-Martin, B.L., Martin, G.K. & Coats, M.D. (1987) *American Journal of Otolaryngology* 8, 73-81

Quaranta, A. & Cervellera, G. (1974) Masking level differences in normal and pathological ears. *Audiology* 13, 428-431

Quaranta, A. (1988) Evaluation of subclinical lesions of auditory function in subjects with thyroid dysfunction. Presented at the 19th International Congress of Audiology, Jerusalem June

Renaer, M. (1981) *Pelvic pain in women*. Springer-Verlag, New York 1981

Renaer, M., Nijs, P., Van Assche, A. & Vertommen, H. (1980) Chronic pelvic pain without obvious pathology. Personal observations and a review of the problem. *European Journal of Obstetrics, Gynaecology and Reproductive Biology* 10, 415 - 463

Repp, B.H. (1977) Measuring laterality effects in dichotic listening. *Journal of the Acoustical Society of America* 62, 720-737

Robinson, D.W. & Sutton, G.J. (1979) Age effect in hearing - a comparative analysis of published threshold data. *Audiology* 18, 320-334

Robinson D.W., Wilkins, P.A., Thyer, N.J. & Lawes, J.F. (1984) Auditory impairment and the onset of disability and handicap in noise-induced hearing loss. Institute of Sound and Vibration Research Technical Report No. 126,

University of Southampton

Rosenhall, U., Pedersen, K. & Moller, M.B. (1987) Self-assessment of hearing problems in an elderly population. *Scandinavian Audiology* 16, 211-217

Rosenthal, W.S. & Wohlert, K.L. (1973) Masking level difference (MLD) effects in aphasic children. Annual convention of the American Speech and Hearing Association (1973)

Rosnow, R.L. & Rosenthal, R. (1970) Volunteer Effects in Behavioural Research. In: Newcomb, T.E. (Ed). *New Directions in Psychology* 4. Holt, Rinehart & Winston, Inc., USA, pp211-280

Rowland, J.P., Dirks, D.D., Dubno, J.R. & Bell, T.S. (1985) Comparison of speech recognition-in-noise and subjective communication assessment. *Ear and Hearing* 6 (6), 291-295

Rudin, R., Rosenhall, U. & Svardsudd, K. (1988) Hearing capacity in samples of men from the general population. *Scandinavian Audiology* 17, 3-10

Rutten, W.L.C. (1980) Evoked acoustic emissions from within normal and abnormal human ears: comparison with audiometric and electrocochleographic findings. *Hearing Research* 2, 263-271

Rutten, W.L.C. & Kuper, P. (1982) AP masking and AP tuning in normal and pathological human ears. *Hearing Research* 8, 157-178

Sandel, T.T., Teas, D.C., Feddersen, W.E. & Jeffress,

- L.A. (1955) Localisation of sound from single and paired sources. *Journal of the Acoustical Society of America* 27, 842-852
- Saunders, G.H. & Haggard, M.P. (1987) *Obscure Auditory Dysfunction in people with clinically 'normal' hearing.* Otorhinolaryngological Research Society, Bradford, April.
- Saunders, J.C., Dear, S.P. & Schneider, M.E. (1985) The anatomical consequences of acoustic injury: a review and tutorial. *Journal of the Acoustical Society of America* 78, 833-860
- Schacht, J. & Canlon, B. (1985) Noise-induced changes of cochlear energy metabolism. In: Dreschler D.G (Ed). *Auditory Biochemistry.* Springfield, USA, pp389-400
- Schow, R.L. & Tannahill, J.C. (1977) Hearing handicap scores and categories for subjects with normal and impaired hearing sensitivity. *Journal of the American Auditory Society* 3, 134-139
- Shailer, M.J. & Moore, B.C.J. (1983) Gap detection as a function of frequency, bandwidth and level. *Journal of the Acoustical Society of America* 74(2), 467-473
- Silva, P.A. (1988) The prevalence of otitis media with effusion in New Zealand children and some long-term consequences for development: A longitudinal study. Presented at the 19th International Congress of Audiology, Jerusalem June
- Silva, P.A., Chalmers, D. & Stewart, I. (1986) Some audiological, psychological, educational and behavioural characteristics of children with bilateral otitis media

with effusion: a longitudinal study. *Journal of Learning Disorders* 19, 165-169

Silva, P.A., Kirkland, C., Simpson, A., Stewart, I.A. & Williams, S.M. (1982) Some developmental and behavioural problems associated with bilateral otitis media with effusion. *Journal of Learning Disorders* 15, 417-421

Sin, G. (1987) Factors influencing the perception of spoken sentences in the elderly. Unpublished Ph.D. Thesis, University of Nottingham, pp90-91

Smootenburg, G.F. (1986) Speech perception in individuals with noise-induced hearing loss and its implication of hearing loss criteria. In: Salvi, R.J., Henderson, D. & Hamernik, R.P. (Eds). *Basic and Applied Aspects of Noise-Induced Hearing Loss*. Plenum Press, New York, pp335-344

Smootenburg, G.F., de Laat, J.A.P.M., & Plomp, R. (1982) The effect of noise-induced hearing loss on the intelligibility of speech in noise. *Scandinavian Audiology Supplement* 16

Speaks, C., Jerger, J. & Trammell, J. (1970) Measurement of hearing handicap. *Journal of Speech and Hearing Research* 13, 768-776

Springer, S.P. & Deutsch, G. (1985) *Left Brain, Right Brain*. Freeman & Co., New York

Stelmachowicz, P.G., Jesteadt, W., Gorga, M.P. & Mott, J. (1985). Speech perception ability and psychophysical tuning curves in hearing-impaired listeners. *Journal of the Acoustical Society of America* 77, 620-627

- Stephens, S.D.G. (1969) Auditory threshold variance, signal detection theory and personality. *International Audiology* 8, 131-137
- Stephens S.D.G. (1987) Audiological rehabilitation. In: Kerr, A.G. (Ed). *Scott-Brown's Otolaryngology* 5th Edition, Volume 2 - Adult Audiology. Butterworths, London, pp446-480
- Stephens, S.D.G & Rendell, R.J. (1988) Auditory disability with normal hearing. In: Quaranta, A. (Ed). *Quaderni di Audiologia*, Volume 4 - Clinical Audiology. Laterza, Bari, pp233-237
- Stevens, S.S. & Newman, E.B. (1936) The localisation of actual sources of sound. *American Journal of Psychology* 48, 297-306
- Sumby, W.H. & Pollack, I. (1954) Visual contribution to speech intelligibility in noise. *Journal of the Acoustical Society of America* 26 (2), 212-215
- Summerfield, A.Q. (1987) Speech perception in normal and impaired hearing. *British Medical Bulletin* 43, 909-925
- Suter, A.H. (1978). The ability of mildly hearing-impaired individuals to discriminate speech in noise. (EPA Report 550/9-78-100) Environmental Protection Agency, Washington DC 20460, USA
- Swan, I.R.C. & Gatehouse, S. (1988) Factors influencing consultation for management of hearing disability. In press for publication in the *British Journal of Audiology*
- Tanner, W.P. Jr., & Swets, J.A. (1954) A decision-making

theory of visual detection. Psychological Review 61, 401-409

Taylor, H.C. (1949) Vascular congestion and hyperemia I Physiologic basis and history of the concept. American Journal of Obstetrics and Gynaecology 57, 211 - 230

Taylor, W., Pearson, J.C.C., Mair, A. & Burns, W. (1965) Study of noise and hearing in jute weaving. Journal of the Acoustical Society of America 38, 113-120

Theobald, G.W. (1951) Pelvis Sympathetic Syndrome. Journal of Obstetrics and Gynaecology Br. Emp. 58, 733-761

Thomas, P.D., Hunt, W.C., Garry, P.J., Hood, R.B., Goodwin, J.M. & Goodwin, J.S. (1983) Hearing acuity in a healthy elderly population: effects on emotional, cognitive and social status. Journal of Gerontology 38, 321-325

Tompkinson, J. (1985) B. Med. Dissertation, University of Nottingham.

Tuplin, J. (1985) Comparison of two methods of measuring auditory frequency resolution and their relationship to speech identification. Unpublished HNC Dissertation, Peoples College of Further Education, Nottingham.

Tyler, L.K. & Wessels, J. (1983) Quantifying contextual contributions to word recognition processes. Perception and Psychophysics 34 (5), 409-420

Tyler, L.K. & Wessels, J. (1985) Is gating an on-line task? Evidence from naming latency data. Perception and

Psychophysics 38 (3), 217-222

Tyler, R.S. & Smith, P.A. (1983) Sentence identification in noise and hearing handicap questionnaires. *Scandinavian Audiology* 12, 285-292

Tyler, R.S., Wood, E.J. & Fernandes, M.A. (1982a) Frequency resolution and hearing loss. *British Journal of Audiology* 16, 46-63

Tyler, R.S., Summerfield, A.Q., Wood, E.J. & Fernandes, M.A. (1982b) Psychoacoustic and phonetic temporal processing in normal and hearing impaired listeners. *Journal of the Acoustical Society of America* 72 (3), 740-752

Utley, J. (1946) A test of lipreading ability. *Journal of speech disorders* 11, 109-116

Vogten, L.L.M. (1974) Pure-tone masking: a new result from a new method. In: Zwicker, E. & Terhardt, E. (Eds). *Facts and Models in Hearing*. Springer-Verlag, Berlin

Wechsler, D. (1958) *The Measurement and Appraisal of Adult Intelligence, Fourth Edition*. Williams & Wilkins, New York

Weinstein, B.E. & Ventry, I.M. (1982) Hearing impairment and social isolation in the elderly. *Journal of Speech and Hearing Research* 25, 593-599

Wielgosz A.T. & Earp, J. (1986) Perceived vulnerability to serious heart disease and persistent pain in patients with minimal or no coronary disease. *Psychosomatic Medicine* 48 (1/2), 119 - 124

World Health Organisation (1980a). International Classification of Impairments, Disabilities and Handicaps - a manual of classification relating to the consequences of disease. WHO, Geneva, 1980

World Health Organisation (1980b) Prevention of deafness and hearing. Report by the Director-General 39th World Health Assembly

Yost, W.A., Wightman, F.L. & Green, D.M. (1971) Lateralisation of filtered clicks. *Journal of the Acoustical Society of America* 50, 1526-1531

Young, L.L. & Wilson, K.A. (1982) Effects of acetylsalicylic acid on speech discrimination. *Audiology* 21, 342-349

Zwicker, E. (1974) On a psychoacoustical equivalent of tuning curves. In: Zwicker, E. & Terhardt, E. (Eds). *Facts and Models in Hearing*. Springer-Verlag, Berlin

Zwicker, E. & Schorn, K. (1982) Temporal resolution in hard-of-hearing patients. *Audiology* 21, 474-492