

Krasachol, Ladawan (1999) The development of quality management in Thailand. PhD thesis, University of Nottingham.

**Access from the University of Nottingham repository:**

<http://eprints.nottingham.ac.uk/11470/1/301664.pdf>

**Copyright and reuse:**

The Nottingham ePrints service makes this work by researchers of the University of Nottingham available open access under the following conditions.

This article is made available under the University of Nottingham End User licence and may be reused according to the conditions of the licence. For more details see:  
[http://eprints.nottingham.ac.uk/end\\_user\\_agreement.pdf](http://eprints.nottingham.ac.uk/end_user_agreement.pdf)

**A note on versions:**

The version presented here may differ from the published version or from the version of record. If you wish to cite this item you are advised to consult the publisher's version. Please see the repository url above for details on accessing the published version and note that access may require a subscription.

For more information, please contact [eprints@nottingham.ac.uk](mailto:eprints@nottingham.ac.uk)



**School of Mechanical, Materials, Manufacturing  
Engineering & Management**

**The Development of  
Quality Management in Thailand**

**by**

**Ladawan Krasachol  
BSc. , MSc.**

**Thesis submitted to the University of Nottingham for  
the degree of Doctor of Philosophy**

**June 1999**

## ABSTRACT

This thesis presents the results of an investigation into the development of quality management in Thailand. The research was conducted in order to draw up an overall picture of quality progress in Thai industry, to provide useful insights for Thai companies and policy-makers, as well as to compare Thailand with other developing countries.

This research has adopted an integrated approach to research methodology comprising both survey and case study methods. Four linked empirical research projects were conducted to obtain an insight into quality management, particularly the ISO 9000 series of quality systems standards, Total Quality Management (TQM), and a 'foundation level' quality system, within Thai industry. The in-depth study of ISO 9000 implementation identifies the driving forces encouraging Thai industry to pursue ISO 9000; four types of ISO 9000 implementation process; implementation factors and obstacles; the impact of implementation process and future plans after a company has achieved ISO 9000 registration. The study of TQM implementation in companies located in Thailand reveals that the companies studied have each adopted different, but successful, approaches to TQM implementation. The Thai Foundation Quality System Standard (TFQSS) has been proved to be suitable for Thai SMEs. Findings from the four individual research project together provide some new insights into the development and implementation of quality management in a Thai perspective.

---

As a result of the study, a TQM framework was developed. The framework identifies three broad dimensions of quality management in a Thai organisation, which are:-

- Three aspects of quality management;
- Five stages of development; and
- Four implementation paradigms.

An organisation that wishes to embark on a quality journey can examine its status against the framework in order to start, or to improve a particular aspect that is found to be unsatisfactory.

After identifying some criteria for the assessment of national quality development, a simple model of quality management in developing countries is proposed to depict comparative characteristics of quality management within these countries. It is concluded that, among developing countries in South and East Asian region, Thailand is in the middle of the spectrum of development.



## ACKNOWLEDGEMENTS

This thesis describes an extensive research programme carried out by the author. Because of the wide scope of the work, a number of people and organisations have contributed in many ways to the research. Their support, co-operation and assistance have been instrumental to the completion of this thesis. In particular, I would like to thank:

My supervisor, Dr. James D.T. Tannock for his invaluable advice, professional guidance, and unlimited support. It has been a great pleasure working with him during the 'learning' process of a PhD. Dr. Tannock had particular involvement with the 'TFQSS' project described later for which he acted as academic consultant.

Mr. Phillip Willey, who supervised the primary stages of this study and provided its initial impetus. His guidance during the early phase was greatly appreciated. Thanks also to Professor Christopher O'Brien for his support.

My sponsor, the Royal Thai Government who funded my research, and also my employer, the National Science and Technology Development Agency (NSTDA) who allowed me a long period of absence in which to complete my thesis, and gave me valuable support in data collection. I am deeply indebted to Professor Naksitte Coovattanachai, the Deputy Director of NSTDA. Without his support and continued encouragement throughout the past four years this thesis would not have been completed. I am grateful to

---

Professor Yongyuth Yuthavong, the former Director of NSTDA, who permitted me to conduct the research within NSTDA projects.

Dr. Paritud Bhandhubanyong, who provided very helpful suggestions as well as information regarding Thai quality management. I would also like to thank Dr. Sumol Pavittranon and Flt. Lt. Bunjob Suktat for their ongoing encouragement and support.

All companies involved in this research project, who provided vital opportunities for research in their organisations. This includes the 217 companies that responded to the survey questionnaire and the 13 companies that were very open and informative during the course of the research. Special thanks go to Mr. Somnuck Wiroonpong at Read-Rite (Thailand) Co., Ltd., Mr. Phaosing Nuangchamnong at Toshiba Consumer Product (Thailand) Co., Ltd., and Mr. Marut Mangklabruks at Siam Refractory Industry Co., Ltd., who allowed me to utilise their companies as successful case studies of TQM implementation in Thailand.

My colleagues at STQC section, NSTDA, who have provided so much help throughout the research project. I am especially grateful to Tipawan, Somchai, Budsaporn, Patcharee, Nattaka, Karnjana, Chittikarn and Patcharin, who assisted in the administration of the survey questionnaire, and in contacting collaborating companies. Their enthusiastic support, their excellent teamwork, and the fruitful discussion they provided were an ongoing foundation for my work. I also would like to thank Mr. George Ridge, with

---

whom I worked in a consulting team, for furnishing a helpful analysis on the ISO 9000 quality system of participating companies.

All the staff and friends in the Division of Manufacturing Engineering & Operations Management. Special thanks are due to Mrs. Ann Wright for her support, Dr. Richard Barson, Mr. Nick Cope and Mr. Matthew Sanders for their help on computing facilities. Thanks also go to Farbod, Anitha and Mary who helped me improve my English writing. I wish to thank Eric, Danupun, Sittichai, Duangpun, Thapin, Chatchalee, Pimol, Unchulee, Lorraine and Kathrin for their companionship, feedback, insights and willingness in helping me towards completion.

The final and greatest thanks go to all the members of my family. I am especially indebted to my husband, Kampanat Krasachol, and my daughter, Natchanat Krasachol, who have suffered from my long absence during the course of this study in the UK. Thanks also go to Mr. and Mrs. Luckit, my great uncle and great aunt, for their support, care and encouragement. Most of all words cannot express my gratitude to my parents, Mr. Sathien and Mrs. Naruemon Itthipathachai, who have always been there for me and to whom I dedicate this thesis.



---

**CONTENTS**

<b>Abstract .....</b>	<b>ii</b>
<b>Acknowledgements .....</b>	<b>iv</b>
<b>Contents .....</b>	<b>vii</b>
<b>List of figures.....</b>	<b>xii</b>
<b>List of tables .....</b>	<b>xiv</b>
<b>List of abbreviations .....</b>	<b>xv</b>
<b>1. Introduction.....</b>	<b>1</b>
1.1 Background to the research .....	2
1.2 Objectives of the research .....	5
1.3 Research methodology .....	6
1.3.1 <i>Research methodology framework</i> .....	7
1.3.2 <i>Research methods</i> .....	11
1.4 Structure of the thesis .....	14
<b>2. Themes in quality management - Literature review .....</b>	<b>16</b>
2.1 Introduction .....	16
2.2 Quality concepts and their development .....	17
2.2.1 <i>Evolution of quality management</i> .....	17
2.2.2 <i>Definitions of quality</i> .....	21
2.2.3 <i>Various angles on quality management</i> .....	23
2.2.4 <i>Practical aspects in TQM implementation</i> .....	31
2.2.5 <i>Research on quality management</i> .....	34
2.3 The ISO 9000 series of quality systems standards .....	37
2.3.1 <i>The concept of ISO 9000 and future trends</i> .....	38
2.3.2 <i>Research on ISO 9000</i> .....	40
2.3.3 <i>Criticisms of ISO 9000</i> .....	41
2.4 Japanese approaches to quality .....	45
2.4.1 <i>Quality control circles (QCCs)</i> .....	46
2.4.2 <i>The seven QC tools and the seven management tools</i> .....	47
2.4.3 <i>5-S practice</i> .....	49
2.4.4 <i>Suggestion systems</i> .....	50

---

---

2.4.5	<i>Company-wide quality control (CWQC)</i> .....	51
2.4.6	<i>Just-in-Time (JIT)</i> .....	52
2.4.7	<i>Total productive maintenance (TPM)</i> .....	53
2.4.8	<i>Kaizen</i> .....	55
2.5	Quality management in developing countries.....	56
2.5.1	<i>Singapore</i> .....	56
2.5.2	<i>Hong Kong</i> .....	57
2.5.3	<i>Taiwan</i> .....	59
2.5.4	<i>Korea</i> .....	60
2.5.5	<i>Malaysia</i> .....	61
2.5.6	<i>India</i> .....	63
2.5.7	<i>People's Republic of China</i> .....	64
2.6	Quality management and national traits.....	66
2.7	Summary .....	68
<b>3.</b>	<b>Quality management in Thai industry</b> .....	<b>70</b>
3.1	Background to Thai manufacturing industry .....	70
3.2	Role of quality management in Thai manufacturing industry.....	72
3.2.1	<i>The export market</i> .....	73
3.2.2	<i>Domestic demand</i> .....	74
3.3	Background to and application of quality management in general ..	75
3.3.1	<i>ISO 9000 series of quality systems standards</i> .....	77
3.3.2	<i>Total quality management (TQM)</i> .....	80
3.3.3	<i>Quality awards</i> .....	82
3.4	Summary .....	84
<b>4.</b>	<b>The Progress of quality management in Thailand</b> .....	<b>86</b>
4.1	Introduction .....	86
4.2	Questionnaire and survey .....	87
4.3	ISO 9000 in Thailand .....	90
4.4	The importance and effect of ISO 9000 implementation.....	94
4.5	Total quality management implementation.....	98
4.6	Quality management tools.....	98
4.7	TQM progress .....	98
4.8	Summary and conclusions.....	102

---



---

<b>5.</b>	<b>The implementation of ISO 9000 in Thai industry.....</b>	<b>103</b>
5.1	Introduction .....	103
5.2	Research process and analysis procedures .....	104
5.3	Background of five case companies and the general implementation process guided by consulting team.....	109
5.3.1	<i>General implementation process guided by consulting team</i> .....	111
5.3.2	<i>Company I</i> .....	116
5.3.3	<i>Company II</i> .....	119
5.3.4	<i>Company III</i> .....	122
5.3.5	<i>Company IV</i> .....	125
5.3.6	<i>Company V</i> .....	127
5.4	Drives for pursuing ISO 9000 .....	130
5.4.1	<i>External drivers</i> .....	130
5.4.2	<i>Internal drivers</i> .....	131
5.5	Implementation process.....	132
5.5.1	<i>Fast-continual implementation</i> .....	135
5.5.2	<i>Slow-continual implementation</i> .....	136
5.5.3	<i>Fast-intermittent implementation</i> .....	137
5.5.4	<i>Slow-intermittent implementation</i> .....	138
5.6	Implementation factors and obstacles .....	139
5.6.1	<i>Teamwork</i> .....	140
5.6.2	<i>Top management</i> .....	140
5.6.3	<i>Workforce</i> .....	141
5.6.4	<i>External influences</i> .....	141
5.6.5	<i>Thai companies - Language difficulty and interpretation.</i> ..	142
5.6.6	<i>Thai Infrastructure</i> .....	143
5.7	Impact of implementation process on company organisation.....	143
5.7.1	<i>Structural change</i> .....	146
5.7.2	<i>Cultural change</i> .....	147
5.7.3	<i>Management change</i> .....	148
5.7.4	<i>Process change</i> .....	149
5.8	Future plan.....	150
5.9	Summary and conclusions.....	151
<b>6.</b>	<b>The adoption of TQM in Thai industry.....</b>	<b>153</b>
6.1	Introduction .....	153
6.2	A theoretical framework for TQM implementation .....	154
6.3	Data collection and analysis method .....	157

---

---

6.4	Analysis of the case studies.....	161
6.4.1	<i>The Siam Refractory Industry Co., Ltd.</i> .....	161
6.4.2	<i>Toshiba Consumer Products (Thailand) Co., Ltd.</i> .....	163
6.4.3	<i>Read-Rite (Thailand) Co., Ltd.</i> .....	165
6.5	Common features of the TQM implementations.....	170
6.6	Conclusions .....	171
<b>7.</b>	<b>The Thai foundation quality system standard (TFQSS).....</b>	<b>173</b>
7.1	Introduction .....	173
7.2	The foundation level quality systems standard .....	174
7.3	The TFQSS development project.....	175
7.4	Developing the TFQSS requirements .....	177
7.5	Implementing the TFQSS in the collaborating companies .....	182
7.6	Conclusions .....	190
<b>8.</b>	<b>Discussion and conclusion.....</b>	<b>192</b>
8.1	Introduction .....	192
8.2	Quality management in Thailand - A TQM framework .....	194
8.2.1	<i>Aspects of quality management</i> .....	198
8.2.2	<i>Stages of development and implementation paradigms</i> ....	201
8.2.3	<i>Evaluation of companies against the framework</i> .....	205
8.3	Key elements for successful TQM.....	211
8.3.1	<i>Management commitment and leadership</i> .....	212
8.3.2	<i>Teamwork and employee involvement</i> .....	212
8.3.3	<i>Employee training and development</i> .....	213
8.3.4	<i>Effective communication within the organisation</i> .....	213
8.3.5	<i>Customer focus</i> .....	214
8.3.6	<i>Performance measurement</i> .....	214
8.3.7	<i>Continuous improvement</i> .....	214
8.4	ISO 9000 series of quality systems standards .....	215
8.4.1	<i>The implementation issue</i> .....	216
8.4.2	<i>The national impact on Thailand</i> .....	217
8.4.3	<i>Impact on organisation</i> .....	220
8.5	Basic quality system.....	220

---



---

8.6	Policy implications for Thailand .....	221
8.6.1	<i>Education</i> .....	222
8.6.2	<i>Calibration systems</i> .....	222
8.6.3	<i>Certification and accreditation systems</i> .....	223
8.6.4	<i>Professional and qualified consultants and assessors</i> .....	224
8.6.5	<i>Research and development</i> .....	225
8.7	Quality management in developing countries - A model.....	226
8.7.1	<i>Nation-wide promotion of quality through education and training</i> .....	229
8.7.2	<i>Competent consultants</i> .....	230
8.7.3	<i>Standardisation, certification and accreditation systems</i> ..	230
8.7.4	<i>The ISO 9000 series of quality systems standards</i> .....	231
8.7.5	<i>Total quality management (TQM)</i> .....	233
8.7.6	<i>National quality award (NQA)</i> .....	234
8.7.7	<i>Perceptions of quality level in the global market</i> .....	235
8.7.8	<i>Research and development (R&amp;D)</i> .....	236
8.8	Limitations of the research.....	238
8.8.1	<i>Selection of case study companies</i> .....	238
8.8.2	<i>Access to the companies</i> .....	239
8.8.3	<i>Secondary data analysis</i> .....	240
8.9	Further research.....	240
8.10	Contribution to knowledge.....	242
	<b>References</b> .....	<b>244</b>
	<b>Appendices</b> .....	<b>258</b>

---

---

**LIST OF FIGURES**

Figure 1-1	Research methodology framework .....	10
Figure 2-1	The history of quality management.....	18
Figure 2-2	Juran Trilogy .....	26
Figure 2-3	Kano's house of quality .....	30
Figure 2-4	Oakland's TQM model .....	30
Figure 2-5	Kehoe's dimensions of quality management.....	30
Figure 2-6	The TQMEX model .....	33
Figure 3-1	ISO 9000 certified companies in Thailand by year of certification .....	78
Figure 4-1	Profile of respondents .....	89
Figure 4-2	Progress of ISO 9000 implementation among respondents .....	91
Figure 4-3	Ownership of the respondents interested in ISO 9000.....	93
Figure 4-4	Size of the respondents interested in ISO 9000 implementation ..	93
Figure 4-5	Reasons for ISO 9000 certification.....	96
Figure 4-6	Relative benefits of ISO 9000 .....	96
Figure 4-7	Benefit measurement of ISO 9000.....	97
Figure 4-8	Activities after certification.....	99
Figure 4-9	TQM gurus.....	99
Figure 4-10	Progress of TQM implementation.....	100
Figure 4-11	Benefit measurement of TQM .....	101
Figure 5-1	Paradigm model .....	107
Figure 5-2	Framework of ISO 9000 implementation .....	110
Figure 5-3	General implementation process guided by consulting team.....	112
Figure 5-4	Documentation structure in the companies .....	115
Figure 5-5	Organisation chart of company I.....	118
Figure 5-6	Organisation chart of company II .....	121
Figure 5-7	Organisation chart of company III .....	124
Figure 5-8	Organisation chart of company IV .....	126
Figure 5-9	Organisation chart of company V .....	129
Figure 5-10	Progression speed and style of ISO 9000 implementation.....	132

---

---

Figure 5-11 Reversed Cause-effect diagram of impact of ISO 9000 on organisation.....	145
Figure 6-1 Case study results - implementation paradigms.....	169
Figure 8-1 Quality management concepts in Thailand - a TQM framework	197
Figure 8-2 Evaluation of TQM framework of the companies in the TQM study.....	208
Figure 8-3 Evaluation of TQM framework of the companies in the ISO 9000 study.....	209
Figure 8-4 Evaluation of TQM framework of the companies in the TFQSS study.....	210
Figure 8-5 Quality spectrum of developing countries - A proposed model .	237



---

**LIST OF TABLES**

Table 1-1	The world competitiveness of selected countries ranked by IMD ...	3
Table 1-2	Key characteristics of positivist and phenomenological paradigms.	8
Table 2-1	Evolution of quality management .....	19
Table 2-2	Some definitions of quality .....	22
Table 2-3	Approaches to quality management of selected authors .....	24
Table 2-4	The ISO survey of ISO 9000 certificates awarded worldwide.....	38
Table 2-5	5-S meanings and typical examples .....	50
Table 2-6	Kaizen vs. Innovation.....	55
Table 3-1	Number of certified companies by certifying body.....	79
Table 4-1	Number of companies interested in ISO 9000 implementation by industrial sector.....	90
Table 4-2	Quality management tools.....	100
Table 5-1	The collaborating companies.....	109
Table 5-2	Some observations of implementation process in case study.....	113
Table 6-1	Culture concepts in TQM .....	155
Table 7-1	TFQSS elements compared with ISO 9000.....	181
Table 7-2	Coverage of Q-Base Code and TFQSS compared with ISO 9000 .....	183
Table 7-3	The collaborating companies.....	184
Table 7-4	Summary of companies position .....	189
Table 8-1	Criteria for assessment of national development of quality management .....	227
Table 8-2	Share in percent of selected countries in the ISO 9000 certifications .....	233

---

**LIST OF ABBREVIATIONS**

AFTA	Asian Free Trade Agreement
APEC	Asia Pacific Economic Cooperation
ASEAN	Association of South East Asian Nations
ASQC	American Society for Quality Control
BPR	Business Process Re-engineering
BSI	British Standards Institute
CWQC	Company-wide Quality Control
EU	European Union
GMP	Good Manufacturing Practice
HKQAA	Hong Kong Quality Assurance agency
IAA	The Korean Industrial Advancement Administration
ISO	The International Organization for Standardization
JIPM	Japan Institute of Plant Maintenance
JIT	Just-In-Time
JUSE	Union of Japanese Scientists and Engineers
KSA	The Korean Standards Association
LTQ	Learning Total Quality
MBNQA	Malcolm Baldrige National Quality Award
NAFTA	North American Free Trade Agreement
NCs	Non compliances
NICs	Newly Industrialised countries
NIST	(US) National Institute of Standards and Technology
NQA	National Quality Award
NSTDA	National Science and Technology Development Agency
PSB	The Singapore Productivity and Standards Board
PTQ	Planning Total Quality
QA	Quality Assurance

---

QC	Quality Control
QCCs	Quality Control Circles
QFD	Quality Function Deployment
QI	Quality Improvement
QMR	Quality Management Representative
SIRIM	The Standards and Industrial Research Institute
SMEs	Small and Medium Enterprises
SOPs	Standard Operating Procedures
SQA	Singapore Quality Award
SQC	Statistical Quality Control
TFQSS	Thai Foundation Quality Systems Standard
TISI	Thai Industrial Standard Institute
TPI	Thailand Productivity Institute
TPM	Total Productive Maintenance
TQC	Total Quality Control
TQM	Total Quality Management
TTQ	Transformational Total Quality
VTQ	Visionary Total Quality

## 1. Introduction

This thesis is a report of an empirical study concerning quality management in Thailand. The study consisted of four linked research projects. An exploratory study was first conducted using a survey methodology in order to identify the current position and trends, as well as attitudes towards quality management within Thai industry. After gaining initial information and ideas from the survey, the researcher conducted further studies to obtain more insight into the key issues of ISO 9000 series standards and Total Quality Management (TQM) implementation in general, and the Thai context in particular. Another study aimed to develop and introduce a “foundation level” quality systems standard, called Thai Foundation Quality System Standard (TFQSS), to Thai small and medium enterprises (SMEs). The results of these four individual research projects together provided some new insights into the development and implementation of quality management in a Thai perspective. Even though the study focused on the Thai context, after a comprehensive review of the literature on quality management in developing countries, especially those in the same South and East Asian region, a comparative viewpoint was postulated, to help explain the progress of quality management in these countries.

---



This first chapter of the thesis presents the background of the study, the objectives of the research and provides an overview of the methodology employed. The chapter concludes by providing the structure of the thesis.

### **1.1 Background to the research**

It has been realised that today competitiveness in the global market is increasingly severe. Owing to the emergence of free trade areas and common markets, such as EU, AFTA and NAFTA, local as well as international markets are no longer protected. Table 1-1 illustrates the world competitiveness of selected countries, especially those in South and East Asian region, ranked by the International Institute for Management Development (IMD). Although Thailand is one of the promising developing nations in the world, in that it has enjoyed rapid economic growth over lengthy periods, its competitiveness has been constantly marginal. In 1997, an economic crisis hit Thailand first and then spread across Asia, forcing the Thai economy into a deep recession as a result of the severe financial problems facing many Thai firms. It is not surprising that Thailand's competitiveness suffered in 1998. Most other developing countries in Asia, such as Korea, Malaysia and Indonesia, had a similar or worse experience.

Generally, it can be asserted that Thailand is in the middle of the range of competitiveness amongst the "small Asian Tiger" countries. For example, its competitiveness lags continually behind Malaysia's but is in front of Indonesia's. Even though Thailand has been facing its currency and economic crisis, Thai manufacturing industry with those of the other ailing "Asian

---



Tigers” is predicted to recover its health and increasingly focus on the achievement of competitive advantage through high quality, as well as cost and productivity efforts which aim to take advantage of favourable exchange rates (Sayle, 1998).

**Table 1-1 The world competitiveness of selected countries ranked by IMD (source: from The World Competitiveness Yearbook by IMD, 1999)**

<b>Overall performance</b>	<b>1992</b>	<b>1993</b>	<b>1994</b>	<b>1995</b>	<b>1996</b>	<b>1997</b>	<b>1998</b>	<b>1999</b>
USA	5	2	1	1	1	1	1	1
Singapore	2	3	2	2	2	2	2	2
Hong Kong	-	-	-	3	3	3	3	7
UK	-	-	-	15	19	10	12	15
Japan	1	1	3	4	4	9	18	16
Taiwan	11	11	22	14	18	23	16	18
Malaysia	14	14	18	23	23	17	20	27
China	-	-	34	31	26	27	24	29
Philippines	33	35	37	36	31	31	32	32
Thailand	26	26	26	27	30	29	39	34
Korea	29	28	32	26	27	30	35	38
Indonesia	37	38	36	34	41	39	40	46

Note: 1992-1998 covers 46 countries.  
1999 covers 47 countries.

There are indeed many factors involved in achieving a competitive advantage. It has been agreed that delivery of quality products and services is a vital dimension of competition and management of quality that could provide the means for gaining and sustaining competitive advantage

(Farquhar, 1991). Many products in international markets are now very mature. Moreover, the products and services provided by different companies and from different countries are not very differentiated. Many corporate companies have discovered that the key to competitive success lies in emphasising product and service quality as a strategic issue in doing business (Belohav, 1993; Kano, 1993 and Pulat, 1994). Hence the quality of product and service is increasingly significant in global competition. Many organisations outside the developed world, especially developing countries in the South East Asian region, has increasingly realised the importance of quality (Hurd, 1992).

Management of quality is a broad subject because there are many issues and interfaces to consider as well as a considerable number of techniques which can be applied. It is an indisputable fact that the ISO 9000 series of quality systems standards (which hereinafter will be generally referred to simply as 'ISO 9000') has become a global phenomenon which cannot be disregarded. ISO 9000 has been acceptable worldwide and its effects are far-reaching. More than a hundred countries including Thailand have adopted it as a national standard. Furthermore, the effects of the adoption of ISO 9000 has and will continue to have in Thailand are significant (Krasachol *et al*, 1998).

TQM is another type of management philosophy which has also been popular in industry for some decades. It has been claimed to be a key management approach for companies to be able to compete successfully in turbulent global markets. In recent years, TQM has also attracted Thai

---

practitioners. General research on both TQM and ISO 9000 has been given wide attention by both academic and practitioners. However, there has been relatively little study on this matter, particularly empirical study, in developing countries including Thailand.

## **1.2 Objectives of the research**

The aims of the research are twofold. The main aim is to examine the development and implementation of quality management in Thailand, in general, and to investigate the ISO 9000 and TQM implementation process on Thai industry in particular, in order to draw up a picture of quality management for Thai industry. The study of overall picture of quality management in Thailand provides a useful perspective for a single nation. In addition, this may also apply to other developing countries. Therefore, the second objective is to compare the Thai perspective on quality management with the situation of other developing countries', especially those in South and East Asian region.

To achieve these aims, the following areas were investigated:

1. Background and development of Thai industry including background and development of quality management adopted in Thai industry.
  2. The current situation, implementation and approach of quality management including ISO 9000 and TQM in Thai industry.
  3. The implementation process of ISO 9000 and the results and effects which stem from the implementation process that might induce companies to change. The changes include the structure of the companies, culture,
-



behaviour and attitudes of management and workforce that may be beneficial (or indeed a drawback) to companies.

4. The implementation of TQM and the characteristics of the companies which have been successfully implementing TQM.
5. In addition a study of the development and pilot implementation of a basic 'foundation' (i.e. sub ISO 9000) model of quality management system suitable for Thai SMEs.
6. Finally, in order to compare Thai perspective on quality management with other developing countries', a literature review on quality management in other developing countries was required.

### **1.3 Research methodology**

As objectives of the research described in the previous section, research questions are formulated as follows:

1. How is quality management developing in Thailand?
  2. What are the current position and trends of quality management in Thai industry?
  3. How are the ISO 9000 standards being implemented in Thai organisations and what is the impact of the implementation?
  4. How is TQM adopted in companies located in Thailand?
  5. Can a basic quality system be developed, suitable for Thai SMEs which are not yet ready for ISO 9000?
-

6. What is the current situation of quality management in other developing countries, especially those in South and East Asian region?

To answer all above questions, research methodology framework was established. It is discussed in the following section.

### **1.3.1 Research methodology framework**

A long-standing debate on choosing a research philosophy (or paradigm) between positivism and phenomenology is still going on. The differences between these two paradigms are illustrated in Table 1-2. Nevertheless, a balance of philosophical position can be achieved in the reality of research (Easterby-Smith *et al*, 1991). This study advocates neither extreme paradigm. It seeks to create a balance between the two.

This study pursues the systematic approach for empirical research provided by Flynn *et al* (1990). It consists of six stages which are:

1. Establish theoretical foundation;
2. Design research which is appropriate to both problem and theoretical foundation;
3. Select data collection method;
4. Implement research empirically;
5. Analyse data; and
6. Prepare research report for publication.

However, since the research problem in this study comprised a number of research questions which are in different area of quality management, the

---



research strategy employed has used multiple methods, each of which is considered to be either a quantitative method within the positivist paradigm or a qualitative method in the phenomenological paradigm.

**Table 1-2 Key characteristics of positivist and phenomenological paradigms (adapted from Easterby-Smith *et al*, 1991 and Gummesson, 1991).**

Positivist paradigm	Phenomenological paradigm
<p><b><u>Basic beliefs:</u></b></p> <ol style="list-style-type: none"> <li>1. The world is external and objective.</li> <li>2. Observer is independent.</li> <li>3. Science is value-free.</li> <li>4. Distinction between science and personal experience.</li> <li>5. Research concentrates on description and explanation.</li> </ol>	<p>The world is socially constructed and subjective.</p> <p>Observer is part of what observed.</p> <p>Science is driven by human interests.</p> <p>Researcher accepts influences from both science and personal experience; they use their personality as an instrument.</p> <p>Research concentrates on understanding and interpretation.</p>
<p><b><u>Researcher should:</u></b></p> <ol style="list-style-type: none"> <li>6. Focus on fact.</li> <li>7. Look for causality and fundamental laws.</li> <li>8. Reduce phenomena to simplest elements.</li> <li>9. Formulate hypotheses and then test them.</li> </ol>	<p>Focus on meanings.</p> <p>Try to understand what is happening.</p> <p>Look at the totality of each situation.</p> <p>Develop ideas through induction from data.</p>
<p><b><u>Preferred methods include:</u></b></p> <ol style="list-style-type: none"> <li>10. Operationalising concepts so that they can be measured.</li> <li>11. Taking large samples.</li> <li>12. Using statistical techniques for quantitative processing of data.</li> </ol>	<p>Using multiple methods to establish different views of phenomena.</p> <p>Small samples investigated in depth or over time.</p> <p>Data are primarily non-quantitative.</p>

According to Flynn *et al* (1990), empirical research can be based on either “a theory-verification” or “a theory-building” approach. In a theory-verification approach, hypotheses are generated in advance of the research, and then tested with the data collected. On the other hand, a theory-building study has no hypothesis in advance. However, a previous theory or constructs which has been proposed from prior studies and from the literature can provide foundations for the research to build on. In this study, theoretical foundation lies on a theory-building approach because the aim of the research is not to test hypotheses but to explain phenomena and the intention has been to add to existing theory or knowledge with new findings based on the empirical data collected.

Figure 1-1 illustrates the research methodology framework employed in this study. Along with literature review, four individual research projects were established to tackle particular research questions. In each research project, the appropriate methods were selected. Yin (1994) pointed out that selecting a research design is very important and research questions should be considered. For research question that focuses on “what” question, a survey method is appropriate. Conversely, “how” and “why” questions can be effectively tackled using a case study approach. An explanation of the research method selection for each particular question follows.

**Figure 1-1 Research methodology framework**

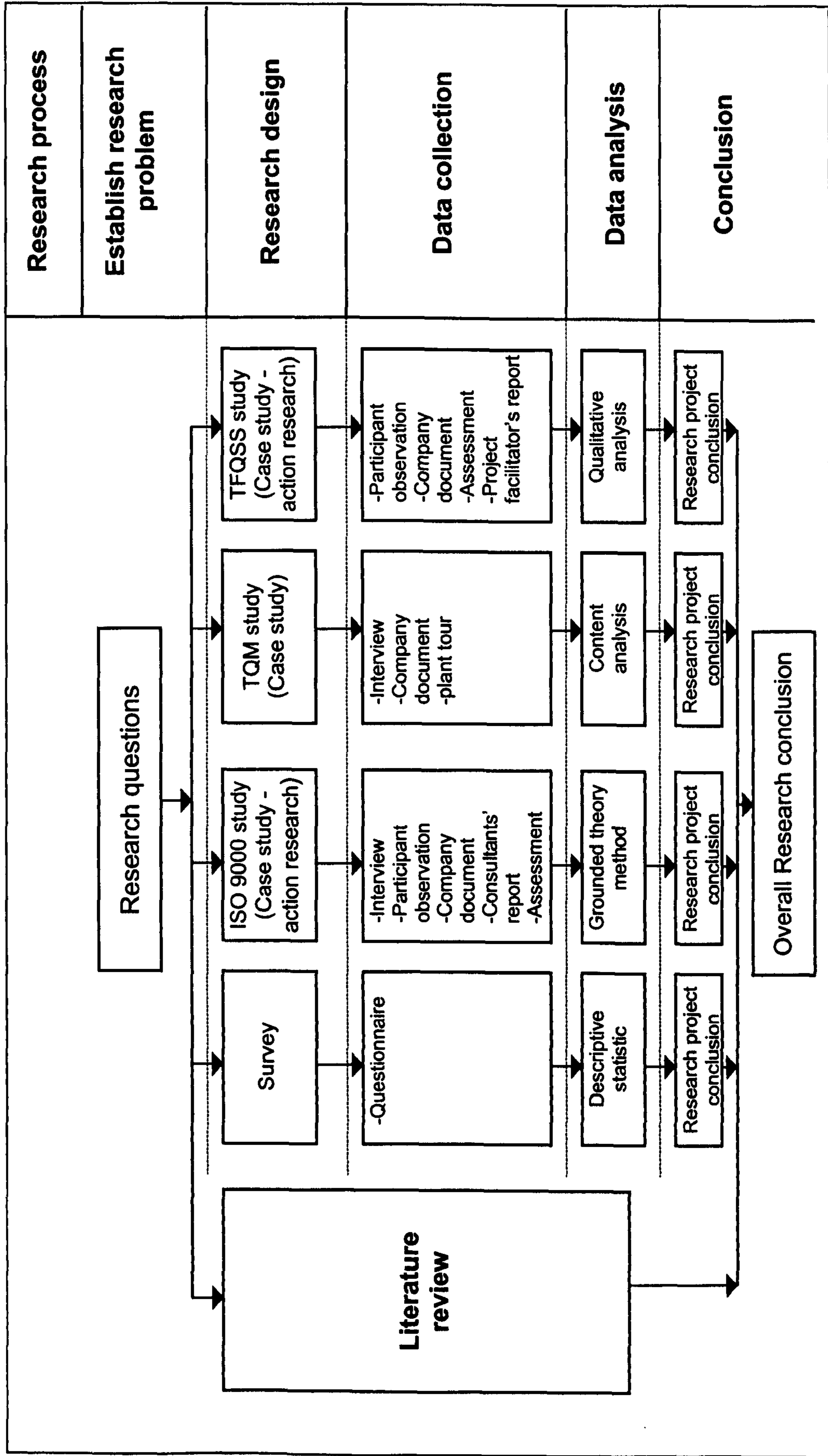



### **1.3.2 Research methods**

#### **Survey method**

A descriptive survey method is used to describe the characteristics of a specific population at a specific point in time (Gill and Johnson, 1997). Therefore, it was used, as an exploratory study, to identify the current position and trends as well as attitudes towards quality management within Thai industry (question 2). The questionnaire was used as a data collection method. Data analysis was done using descriptive statistic. The results of this research project provide background information about quality management, particularly issues about ISO 9000 and TQM, in Thailand. The details of the survey and questionnaire are provided in Chapter 4.

#### **Case study method**

Case study research is the preferred method when “how” and “why” questions are being posed and the focus is on contemporary phenomena within a real-life context (Yin, 1994). Hence, the case study approach is appropriate to investigate how ISO 9000 and TQM are implemented in Thai organisations (question 3 and 4). Both ISO 9000 and TQM research projects are explanatory studies which enlarge the results of the survey method and provide deeper insight into the ISO 9000 and TQM implementation process within Thai industry.

Multiple case study is considered as multiple experiments (Yin, 1994). Cases are chosen for theoretical reasons, not for statistical reasons (Strauss and

---

Corbin, 1990). Multiple case study is designed to produce either a literal or theoretical replication. For a literal replication, each case is selected so that it predicts similar results. On the other hand, a theoretical replication produces contrasting results but for predictable reasons.

A multiple case study approach in the TQM research project was used with the logic of a theoretical replication. The TQM companies selected for investigation gave different results according to a theoretical framework. The details of selection of companies in TQM research project are provided in Chapter 6.

The process of selecting companies in the ISO 9000 research project was described in Chapter 5. However, it is worth noting here that the companies were initially selected according to the criteria provided by a government agency, the Thai National Science and Technology Development Agency (NSTDA), which initiated and supported this project. Hence, the research was not at necessarily expected to produce either the similar or contrasting results.

NSTDA also supported the project “Establishment of a Thai Foundation Quality System Standard (TFQSS) for SMEs”. Since this researcher was responsible for the project as project manager and technical expert, the research on development and implementation of basic level of quality system was carried out using a case study method (to answer question 5). The process of company selection was similar to that of the ISO 9000

---

research project and the same comment applies. This study is described in detail in Chapter 7.

### **Action research**

Action research is accepted as one of the management research methods which not only provides solutions to the problems which are useful for practitioners but also contributes knowledge to the academic community (Jones, 1987, Bryman, 1989, Gummesson, 1991 and Gill and Johnson, 1997).

The definition of action research can be described as follow:

Action research is... processes in which researcher and research participants are working together, although perhaps in different ways and at different points, to develop understanding which both parties want and expect to have an impact on the way they conduct aspects of their lives (Jones, 1987. P.33).

Action research is far-reaching method that can be adopted when working with case study (Gummesson, 1991). It is considered that research should lead to 'change' and therefore the change which occurs should be incorporated into the research process itself (Easterby-Smith *et al*, 1991). In the ISO 9000 and TFQSS projects in which the author was involved as a project manager and technical expert, it provided the opportunity to adopt an action research approach in these two research projects.

The implementation process of ISO 9000 in the ISO 9000 research project, and the basic quality system in the TFQSS project were introduced to the companies participated in the two projects, and the researcher used various kinds of data collection methods, which are described in Chapter 5 and

---



Chapter 7 respectively for the ISO 9000 research project and the TFQSS project, to collect evidence for analysis.

It should be noted that the ISO 9000 project was carried out using a strict action research methodology. It was straightforward action research using experienced consultants. Moreover, data analysis was rigorously carried out using a grounded theory method as described by Strauss and Corbin (1990). The TFQSS project, however, mainly focused on developing a 'foundation level' quality system standard for Thai SMEs. TFQSS is a prototype of basic standard which needs to be validated its application. The action research approach employed in the TFQSS research project was more relaxed than the one in the ISO 9000 project. It aimed to develop an idea to research how things go because often when working with industry the researcher needs to adapt his or her approach to the requirements of time and of collaborators.

#### **1.4 Structure of the thesis**

This chapter has outlined the thesis, and especially highlighted the research methodology employed in the study. Having provided an overall introduction to the research, this thesis is divided into a further seven chapters.

Chapter 2 provides an overview of the literature on quality management and themes in quality management, especially the background and development of quality management in developing countries. Chapter 3

---

provides an overview of the background of the Thai economy and manufacturing development generally, as well as quality management.

Chapter 4, 5, 6 and 7 discuss the individual research projects which are respectively the survey on the progress of quality management in Thailand; the ISO 9000 research project; the TQM research project and the TFQSS research project.

Chapter 8 summarises all the research findings and discusses significant issues concerning the overall picture of quality management in Thailand. Finally the chapter ends with a more general consideration and comparison of quality management in developing countries.

## **2. Themes in quality management - Literature review**

### **2.1 Introduction**

The purpose of this chapter is to present an overview of the literature on quality management. It is necessary to understand the concepts of quality management in order to carry out research in this area. The chapter begins with an outline of basic concepts, to provide the background to the development of quality management. The areas considered are: -

Evolution of quality management;

Definitions of quality;

Various angles on quality management;

Practical aspects in TQM implementation; and

Research on quality management.

Next, the ISO 9000 series of quality systems standards are reviewed. These standards are a global phenomenon, and now represent international quality systems which is accepted worldwide and has been adopted as a national standard in more than a hundred countries. Furthermore, the ISO 9000 continues to be developed, with the new ISO 9000:2000 version coming soon.

---



Owing to Japanese success on the quality journey, it is worth reviewing the Japanese approaches to quality management some of which are well known and adopted in Western countries, but are also influential in developing countries such as Thailand.

Finally, the literature on quality management in developing countries has been reviewed and this review provides a useful comparative picture on levels of quality management development and progress.

## **2.2 *Quality concepts and their development***

### **2.2.1 Evolution of quality management**

The subject of quality management is vast, since there are many issues and interfaces to consider as well as a considerable number of techniques and tools which an organisation is able to apply in their quality journey. A review of the historical background and development of quality management can provide the researcher with good basic knowledge and understanding of these matters.

The history of quality management is well depicted by Lisiecka (1998) as shown in Figure 2-1. During the 20<sup>th</sup> century, quality management has been promoted from an operational level to a strategic management level. Figure 2-1 shows the milestones of quality management development and their leading figures, with of time frame. Alternatively, The evolution of quality management can be simply described in various ways as shown in Table 2-1.

---

**Figure 2-1 The history of quality management (adapted from Lisiecka, 1998)**

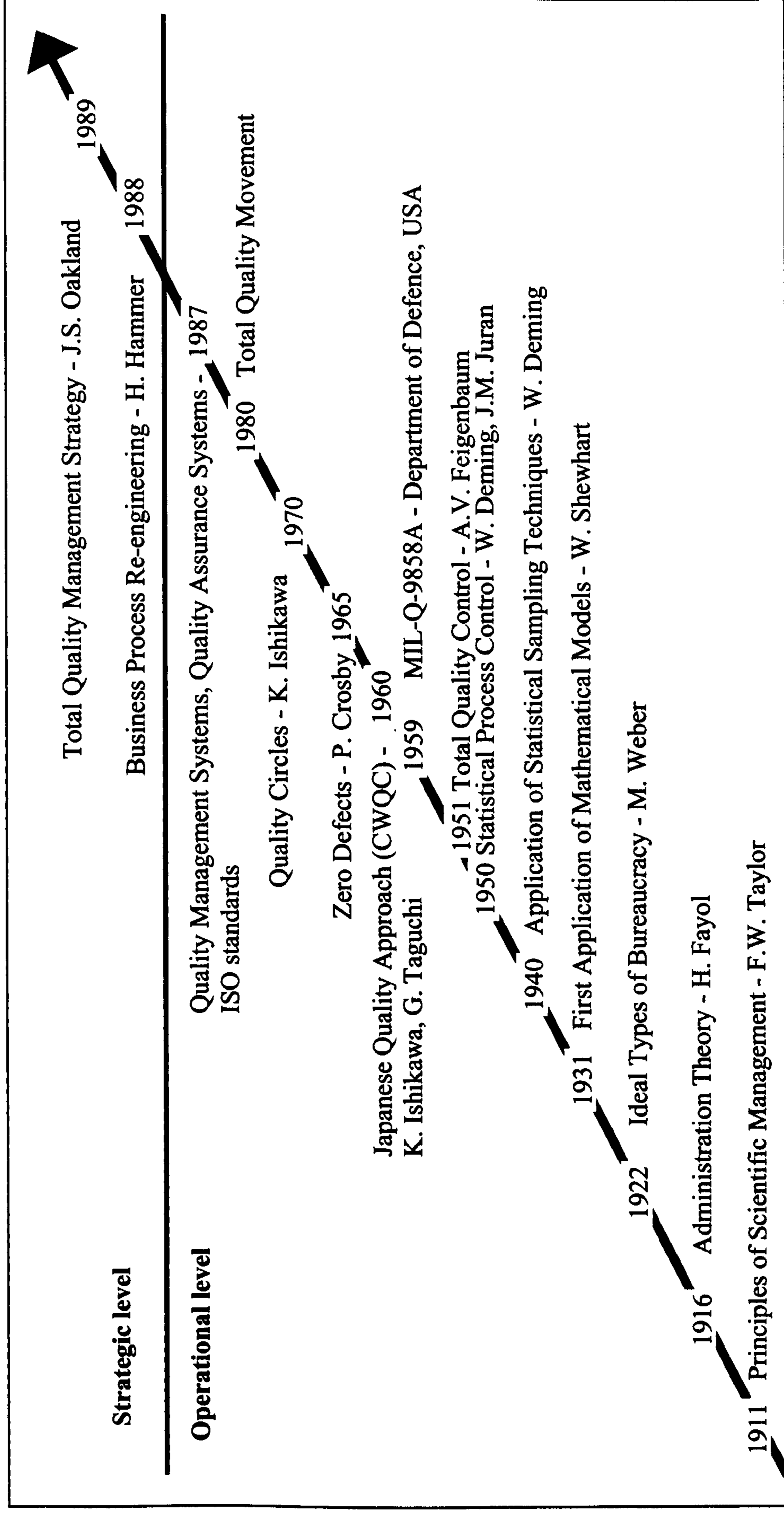

**Table 2-1 Evolution of quality management**

<b>Aspects</b>	<b>Development</b>
Implementation	Technical → Management
Product quality	Detection → Prevention → Improvement
People involvement	QC/QA personnel → Whole organisation
Sense of responsibility	QC/QA function → Whole organisation
Customer aspect	Meet specification → Customer satisfaction/delight

From this table, different aspects of the evolution of quality management may be seen; such as the way it is implemented, product quality, people involvement, sense of responsibility and the customer aspect. In the early days, it can be said that quality was seen as a technical work. Feigenbaum (1991) describes the development of quality control spanning over the 20<sup>th</sup> century. He divides the development of quality into five stages which are operator quality control; foreman quality control; inspector quality control; statistical quality control; and total quality control. In the early period of mass production influenced mainly by scientific management ideas, inspection was introduced as a separate function from production. Before that, product inspection was performed by the worker themselves (operator quality control) and by their foreman (foreman quality control).

In those periods of quality control it is usually considered that a defect-detection approach was employed, where it was an inspector's responsibility



to use various kind of techniques to inspect and identify defective products in order that those defects were separated for rework or scrap as appropriate. Since there was often great market demand, regardless of the customer the aim of many manufacturing organisations was to produce goods which simply conformed to specified requirements. Later, simple inspection activities were substituted or supplemented by quality control, quality assurance and finally total quality control (Dale *et al*, 1990). Nowadays the way people in an organisation, especially higher management, think of quality management has changed. They know that quality has to be considered at a strategic management level, not just in terms of a technical application. The detection approach to quality has developed through defect prevention in an improvement orientation, assisted by the application of Statistical Quality Control (SQC) techniques. Moreover, it has been realised that the total organisation needs to be involved in quality work. Quality is no longer the responsibility of only QC/QA function but is also the duty of everyone in an organisation. The goal of a quality organisation has moved from merely producing products which meet specifications to satisfying or even delighting their customers.

It has now been realised that quality can most effectively be tackled by the proper management of human resources. A management approach which encourages teamwork, good communication and employee involvement is at the heart of managing quality, supported by appropriate techniques and tools.

---

### 2.2.2 Definitions of quality

Many authors (for example Garvin, 1988; Ivancevich *et al*, 1994; and Kolarik, 1995) have reviewed quality definitions. Most of them relate to products and services as well as customers. Some definitions of quality suggested in the literature are shown in Table 2-2. The word ‘quality’ means different things to different people and therefore there are many definitions and interpretations (Lascelles and Dale, 1993).

The meaning of quality is related to its application. An organisation’s understanding of quality may be different from that of its customers’ (Kondo, 1995). Service quality might be defined differently from manufacturing quality. The meaning of the word quality as used for a product is not the same as the word when referring to the whole organisation. Hence, quality should be understood with reference to the type of organisation, level of organisation it refers to, and from which stakeholders’ perspective (i.e. producer or customer) it is viewed (Dotchin and Oakland, 1992). A useful classification that helps in understanding the definition of quality, provided by Garvin (1988), described five different meanings of quality. They are transcendent; product-based; manufacturing-based; user-base; and value-based. It illustrates various meanings of quality based on a different analytical framework. Understanding the meaning of quality is important because different contexts often produce different criteria to measure quality. In short, it should be noted that quality is best defined and judged by the customer. The definition of quality therefore must concern customer expectations.

---



**Table 2-2 Some definitions of quality**

Origin	Definition of quality
Crosby (1980) p. 15	Conformance to requirements.
Deming (1986) p. 168	“Quality can be defined only in terms of the agent... In the mind of the production worker, he produces quality if he can take pride in his work... Quality to the plant manager means to get the numbers out and to meet specifications.
Ishikawa (1988) p. 16	product quality, and moreover, the quality that people will buy with satisfaction.
Juran (1988), p. 2.8	Fitness for use
Juran and Gryna (1993) p. 3	Customer satisfaction
Feigenbaum (1991), p. 7	The total composite product and service characteristics of marketing, engineering, manufacture, and maintenance through which the product and service in use will meet the expectations of the customer.
ISO (1986)	The totality of features and characteristics of a product or service that bear on its ability to satisfy stated or implied needs.
The Ford Motor Company (Lascelles and Dale, 1993)	Quality is defined by the customer. The customer wants products and services that through their life meets his or her needs and expectations at a cost that represents value.
Bergman and Klefsjo (1994), p. 16	The quality of product (article or service) is its ability to satisfy the needs and expectations of the customers.
Taguchi and Wu (1979, cited by Bergman and Klefsjo (1994))	Quality, or rather non-quality, is defined as the losses of society caused by the product after its delivery.
Some Japanese companies (Ho, 1995) p. 5	Providing extraordinary customer satisfaction.
Oxford advance learner dictionary (Crowther, 1995)	1(a) the standard of something when compared to other things like it. (b) a high standard of level.  2(a) a usually good characteristic. (b) a special or distinguishing feature.



---

### 2.2.3 Various angles on quality management

Quality of product and service is the ultimate goal and outcome while quality management is “a dynamic set of activities” to achieve the goal and the outcome (Lascelles and Dale, 1993). Hence, the quality issue does not concern only the products or services which an organisation produces but also the whole organisation including the people within it. As described in section 2.2.1, since quality management started its development, it has been studied, analysed and explained from various angles. The messages of the quality gurus provide different flavour but aim for the same destination. Although the approaches of different gurus to quality management vary somewhat in terms of emphasis, practices and techniques, but they are largely complementary (Oakland, 1993). Several authors and academic have discussed the messages of the gurus and the details of the gurus’ messages have been widely described elsewhere (see for example Logothetis, 1992; Dotchin and Oakland, 1992, Flood, 1993; Bergman and Klefsjo, 1994 and Ho, 1995). They will not be rehearsed in detail here.

Instead, this section aims to identify the fundamentals of quality management which are simple for an organisation to apply. Table 2-3 outlines various frameworks of quality management of selected authors. It is worth noting that some authors use Total Quality Management (TQM) in a broad and conceptual sense. Their TQM conceptual model is incorporated into “the approaches to quality management” presented in this thesis.

**Table 2-3 Approaches to quality management of selected authors**

Crosby (1984)	Four absolutes for quality management
Ishikawa (1988)	CWQC - all functions, all employees, continuous improvement, customer orientation
Juran (1988)	Juran trilogy
Feigenbaum (1991)	Total quality control
Deming (1993)	System of profound knowledge
Kano (1993)	The house of TQM
Oakland (1993)	TQM model
Ho (1995)	The four pillars of TQM
Kehoe (1996a)	The dimensions of quality management

Crosby's (1984) approach to quality management is based on management commitment to quality goals, prevention, and the respect for employees and their efforts. Crosby's name is best known in relations to "do it right first time" and "zero defects". He also views quality management as an ongoing process which is based upon the "four absolutes":

1. Quality is defined as conformance to requirements, neither as 'goodness' nor 'elegance'.
2. The system for causing quality is prevention, not appraisal.
3. The performance standard must be zero defects, not 'that's close enough'.
4. The measurement of quality is the Price of Non-conformance, not indices.

---

Apart from his contribution to the development of problem solving techniques including cause-and-effect (or Ishikawa) diagrams, Kaoru Ishikawa (1988) is also associated with the Company-wide quality control (CWQC) movement which started in Japan in the years 1955-1960. CWQC is described in more details in section 2.4.5.

Juran (1988) emphasises that quality control should be conducted as an integral part of management control. He proposes three managerial processes necessary for quality management which are quality planning; quality control; and quality improvement. This becomes known as the “Juran trilogy” (Figure 2-2). Juran’s ‘quality planning roadmap’ is useful for an organisation starting out in quality management. It consists of the following steps:

1. Identify the internal and external customers and their needs.
2. Translate the customer’s needs into a language everyone can understand, then develop a product which can respond to those needs.
3. Optimise the product by developing and optimising the process which produces this product.
4. Once the operating conditions have been established and proved as the optimal, transfer the process to operations.

In the operation phase, it brings in the second part of the quality trilogy, ‘quality control’ which in this sense means the process of detecting and correcting ‘sporadic problems’ as soon as they occur, so that the status quo is maintained. Only a process that is in control is predictable and hence receptive to efforts for further improvement, which is the third member of the

---



trilogy. In order to reduce chronic waste substantially and achieve a new improved zone of quality control, a quality breakthrough is required which takes an organisation to an unprecedented level of performance.

**Figure 2-2 Juran Trilogy**

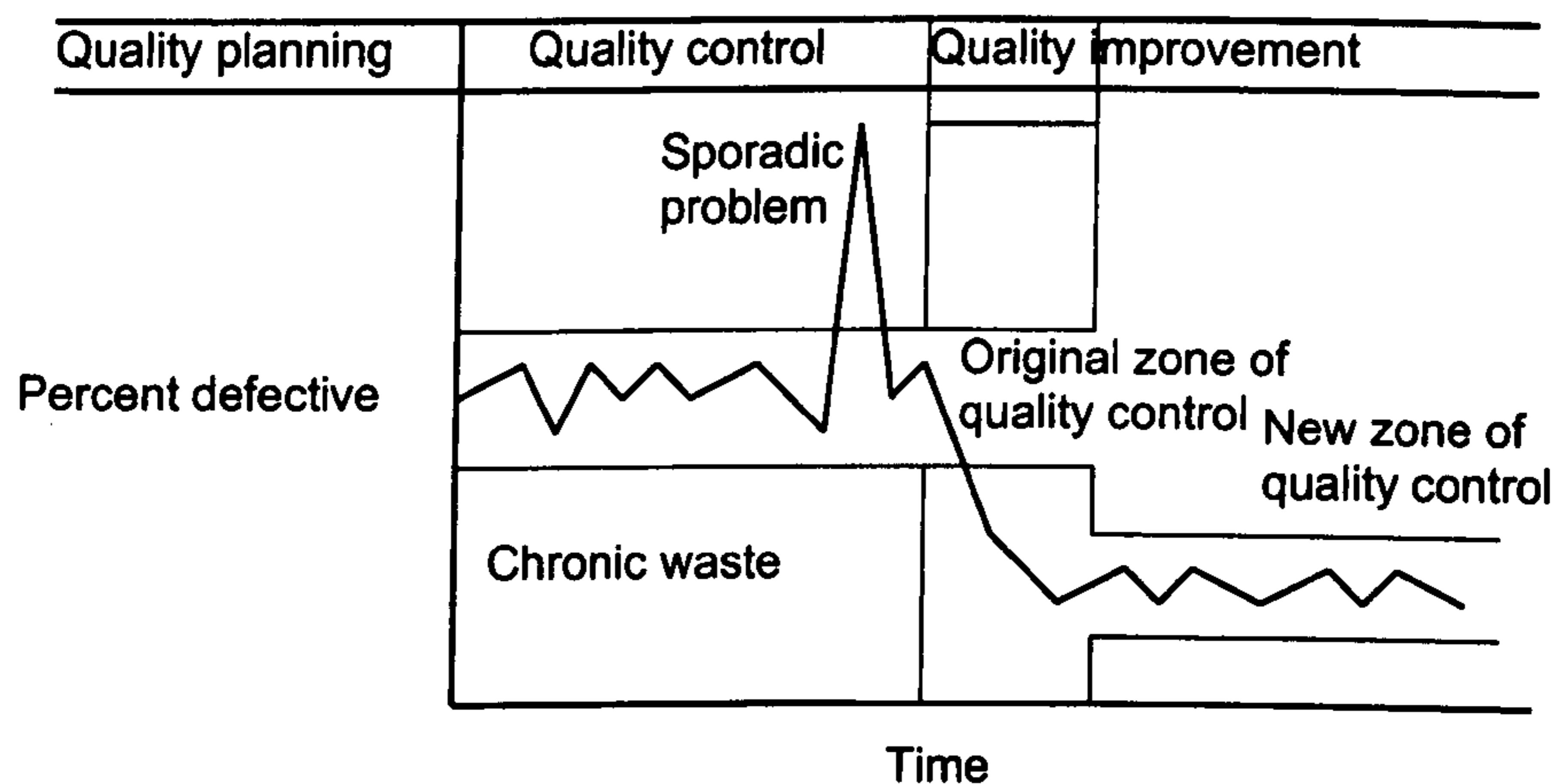

Armand V. Feigenbaum is the originator of the term 'Total Quality Control', the title of his seminal book, the first edition of which was published in 1951. He argued that a systematic or total approach to quality requires the involvement of all functions in the quality process, not just manufacturing. He presented quality control as a business method rather than a technical issue and also contended that quality has become the single most important force leading to organisational success and growth. In the latest 40<sup>th</sup> anniversary edition of his book, he further defines TQC for the 1990s in the form of ten crucial benchmarks for total quality success, and provides four management fundamentals of total quality which are:

1. There is no such thing a permanent quality level. Hence, the only way to compete with quality is with more quality.
2. Leadership in mobilising the quality knowledge, skill, and positive attitudes of all employees in the organisation to recognise that everything is better if they make quality better.
3. Quality is essential for successful innovation.
4. Quality and cost are complementary, not conflicting business objectives.

Feigenbaum consistently emphasises that total quality programmes are “the single most powerful change agent” for companies today.

Deming (1993), before his death in December 1993, summarised his seventy years’ experience and vision and called it the “system of profound knowledge” which has a broader conceptual scope than his previous teaching.

The system of profound knowledge consists four related parts which are:

1. Appreciation for a system. This emphasises the need for managers to understand the relationships between functions and activities.
  2. Knowledge about variation. This includes knowledge about variation, process capability, control charts, interactions and loss functions.
  3. Theory of knowledge. All plans require prediction based on past experience.
  4. Psychology. It is necessary to understand human interactions.
-

---

Kano (1993) explains quality management using the “house of quality” model (Figure 2-3). According to his model, the house’s foundation is the intrinsic technology which is necessary for particular industry, and the floor (which is also important in terms of foundation of the house) is the motivational approach used to create the conditions which impel management and employees to embark on quality management. The roof represents customer satisfaction as the objective of quality management. The three pillars represent the concepts, techniques and promotional vehicles. The concepts are the approaches by which employees including management think of quality. They consist of both theory of quality, such as customer satisfaction and internal-external customer approach, and theory of management, for example the PDCA cycle or management by fact. The second pillar, techniques, contains the various tools which can be used in order to work on quality management. They are for example, the seven QC tools, the seven Management and Planning tools and statistical methods. The final pillar, which is the promotional vehicles, are the methods for effectively promoting all the quality activities, such as policy management, daily management, cross functional management and bottom up activities.

In the UK, the model proposed by Oakland (1993) consists of two foundations: the soft and hard aspects. The core theme of this TQM model is the identification and management of processes within organisations in order to meet internal and external customer requirements. The processes include the ‘soft’ foundation elements, which are culture, communication and commitment, and the three ‘hard’ management necessities, which include a

---



good quality management system; tools such as SPC; and teamwork. Oakland's TQM model is shown in Figure 2-4.

Like Oakland (1993), Kehoe (1996a) states that most organisations embarking on quality journey to improve customer satisfaction and enhance business performance require development in each of the three basic dimensions of quality management which are people; systems; and techniques. The dimensions of quality management are illustrated in Figure 2-5. Through the systematic integration of all three dimensions, an organisation can achieve a breakthrough in operation performance and customer service associated with total quality. Progress in all three dimensions has a potential impact upon the satisfaction of customer, shareholders and employees. These require an understanding of the fundamental principles of quality management and an appreciation of the implementation approaches necessary for practical success.

To summarise, in the author's view the above approaches to quality management are in fact similar in terms of concepts and fundamental principles. Most of the 'total quality' models refer to systems and techniques which are essential for a quality organisation but place particular emphasis on people which are an important resource essential for quality improvement.

**Figure 2-3 Kano's house of quality**

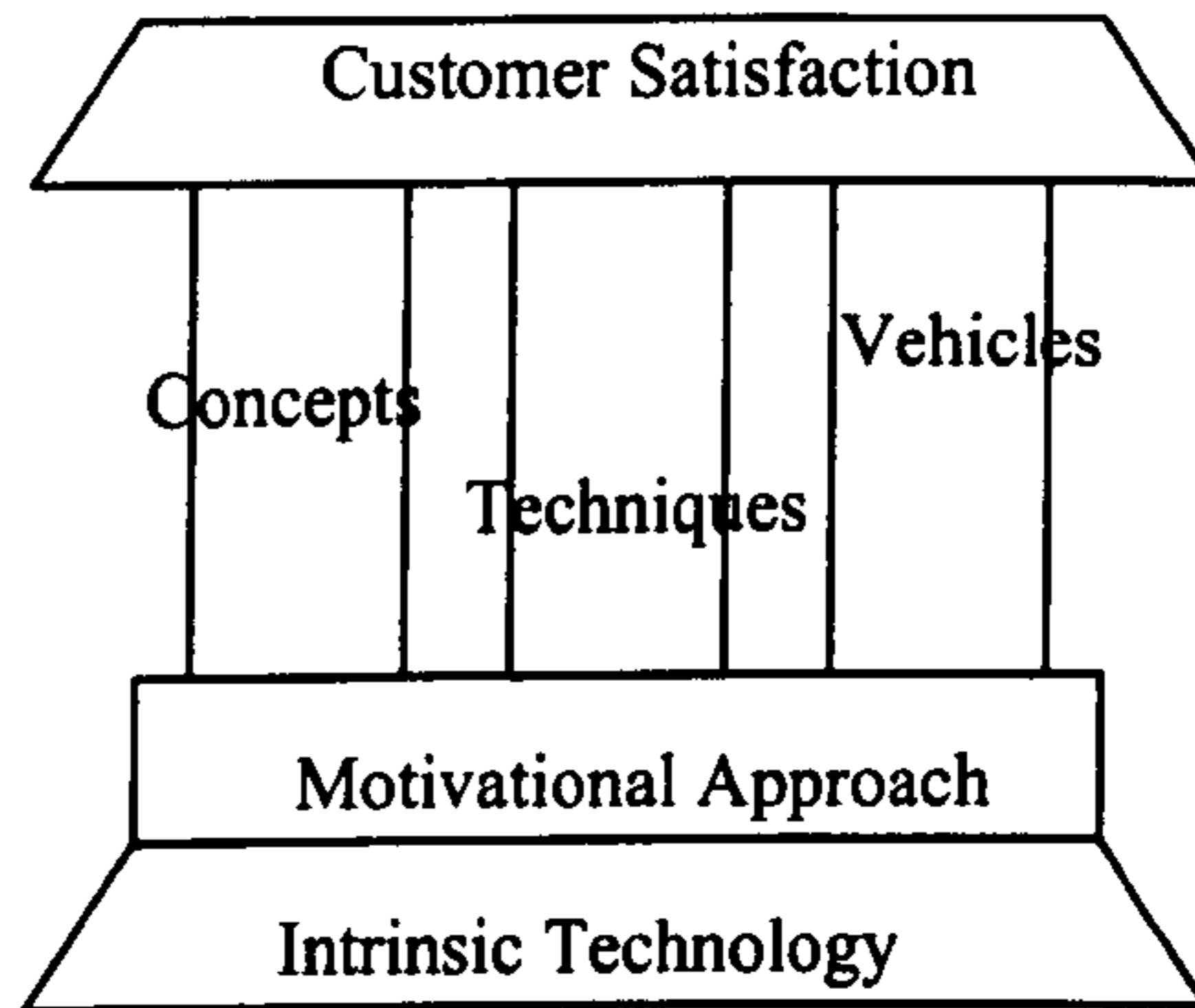

**Figure 2-4 Oakland's TQM model**

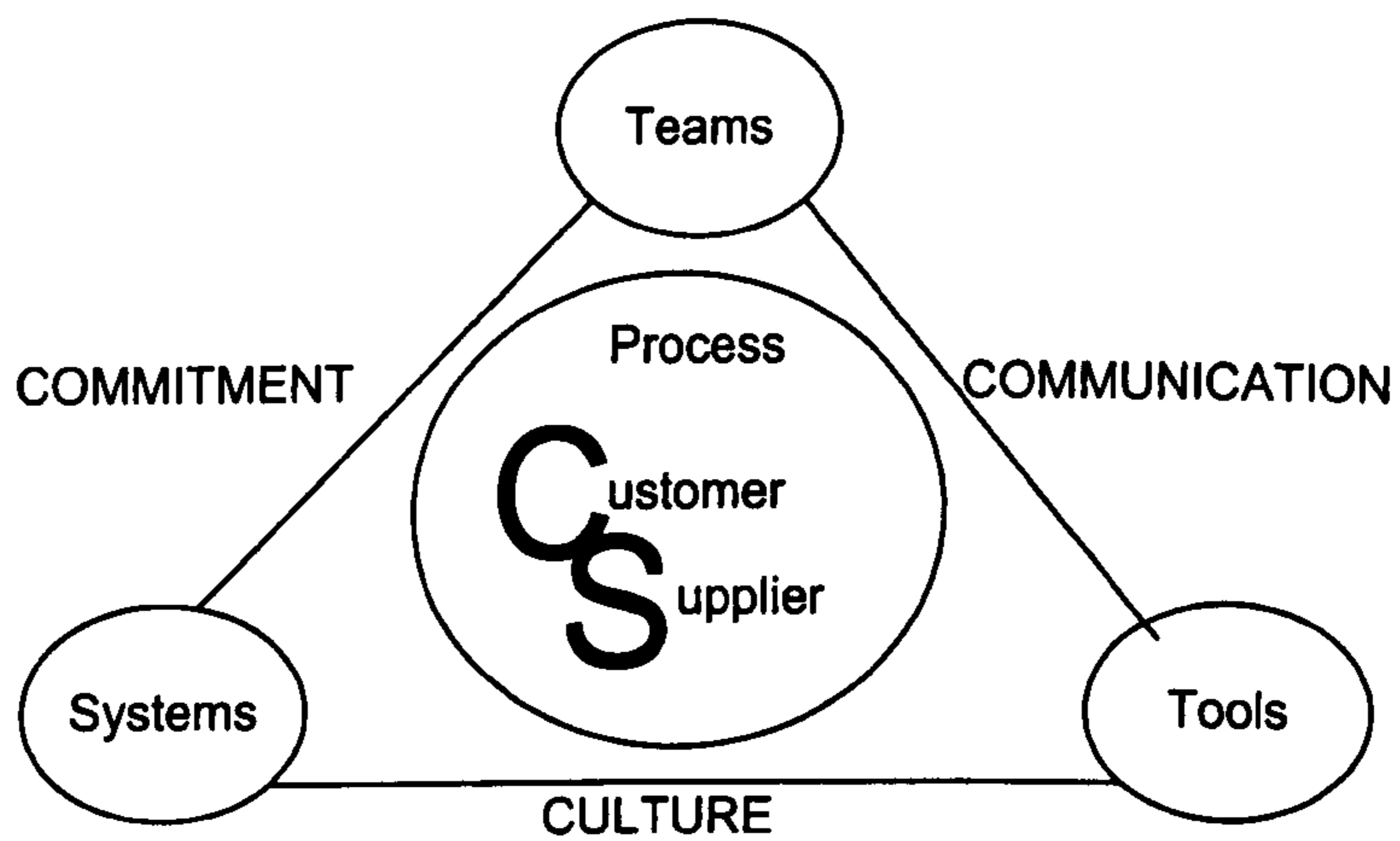

**Figure 2-5 Kehoe's dimensions of quality management**

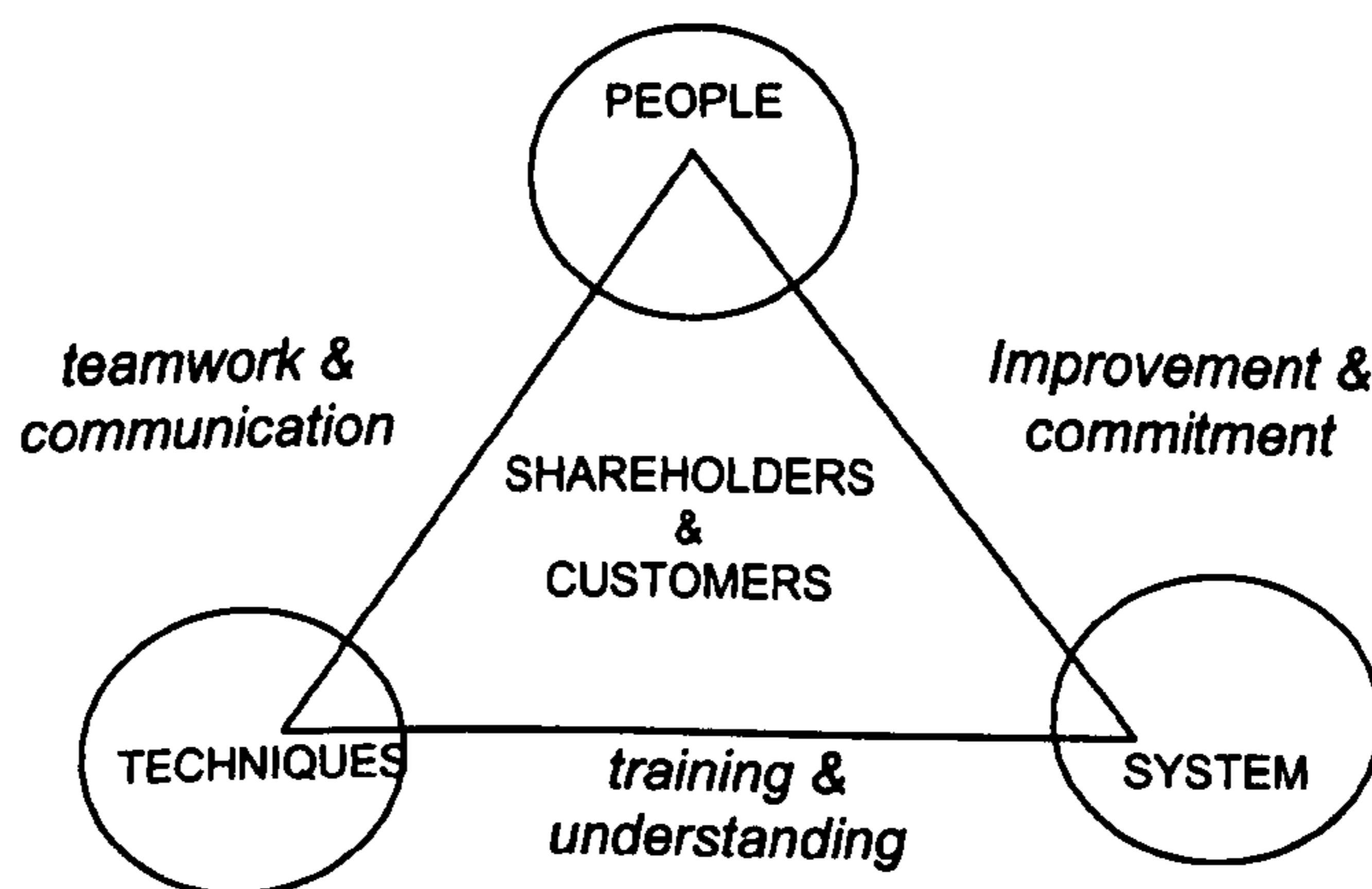

### 2.2.4 Practical aspects in TQM implementation

Total Quality Management has been widely accepted and successfully implemented in many large companies, helping them to compete in international as well as local market through the production of high quality products to satisfy needs of their customers (Dale and Plunkett, 1990). Moreover, the evidence from empirical research confirms that an improvement in quality leads to increase productivity, performance and profits (Terziovski *et al*, 1996). TQM has been described as a new way of thinking about organisation management (Chorn, 1991). The term ‘TQM’ has been widely used as a “generic descriptor of the quality development efforts” in an organisation (Kehoe, 1996a). In implementing TQM, the integrated application of various kinds of techniques should be used within a coherent implementation framework. In this section, the issues surrounding practical approaches for TQM application are reviewed.

There have been many approaches to TQM implementation presented in the literature. Some of them try to provide a recipe for success and even give a step-by-step guide for the TQM process. However, applying individual quality management techniques without first establishing framework of TQM and promoting quality awareness throughout the company can raise misconceptions and misunderstandings which then become barriers to progress (Dale *et al*, 1990).



---

As an example, Dotchin and Oakland (1992) extract ten points, from the words of wisdom in quality management and leadership of the 'gurus', for senior management to consider in their TQM implementation. These are

1. The organisation needs long term commitment to constant improvement.
2. The philosophy of zero defects must be adopted to change the culture to 'right first time'.
3. Train the people to understand the customer-supplier relationship.
4. Do not buy on price alone - look for the total cost.
5. Recognise that improvement of the systems has to be managed.
6. Adopt modern methods of supervision and training - eliminate fear.
7. Eliminate barriers between departments by managing the process - improve communication and teamwork
8. Eliminate goals without methods; work standards based only on numbers; barriers to pride of workmanship; and fiction, get facts by using the correct tools.
9. Constantly educate and retrain - develop 'experts' and 'gurus'.
10. Develop a systematic approach to manage the implementation of TQM.

Ho (1995) proposes the TQMEX Model, shown in Figure 2-6, as an integration approach to TQM implementation. He claims that the model reflects the teachings of quality gurus such as Deming, Juran, Crosby, and

---

Ishikawa. The idea was to develop step-by-step guidelines by including recognised practices in TQM which are: Japanese 5-S; business process re-engineering (BPR); quality control circles; ISO 9001/2 quality management system and TPM.

**Figure 2-6 The QMEX model (Ho, 1995)**

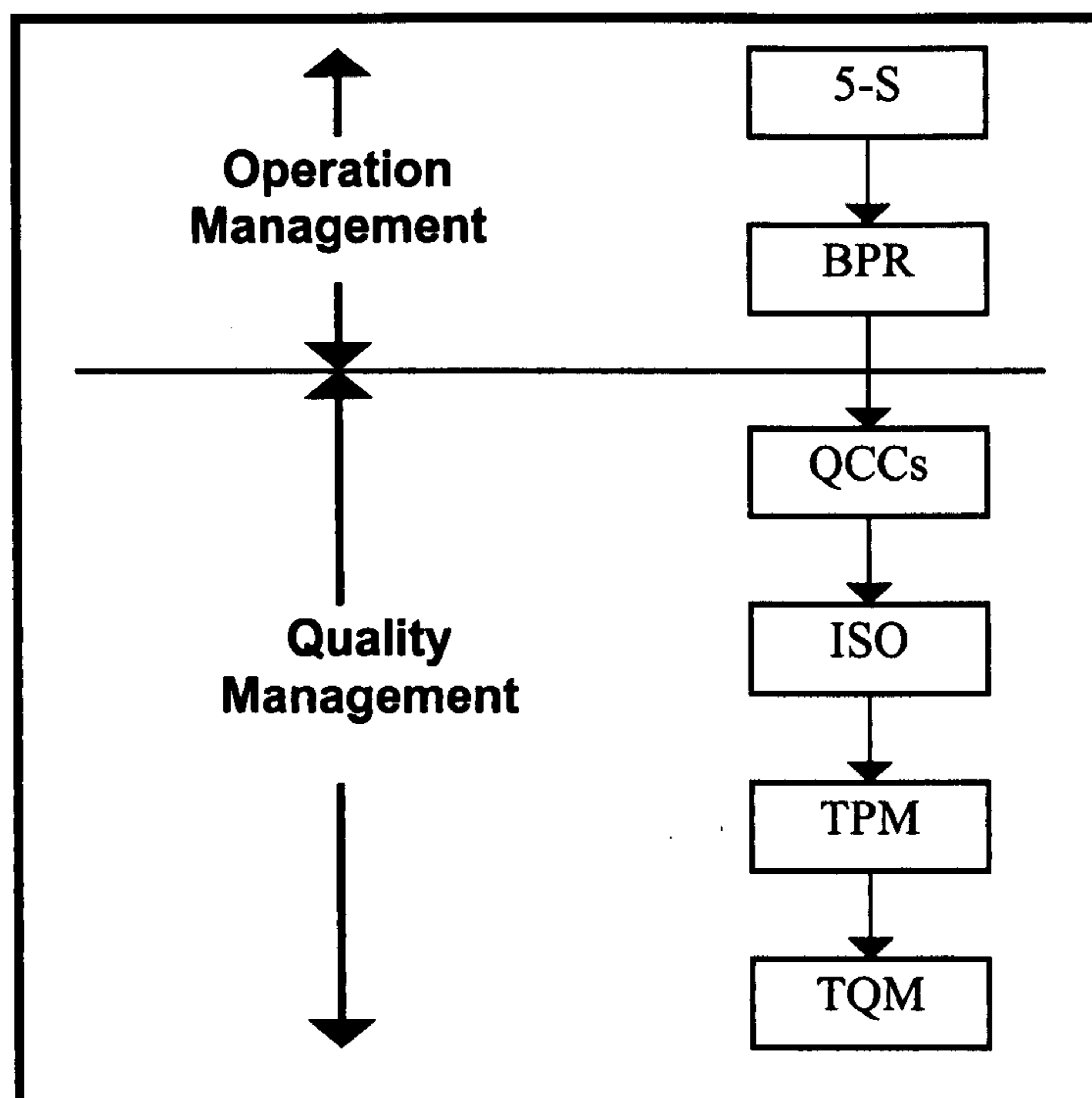

A further important approach to TQM implementation is the use, as a guide, of models underlying the quality awards such as the Malcolm Baldrige National Quality Award (NIST, 1999a), the European Quality Award (EFQM, 1992) and the Deming Prize, all of which incorporate an assessment mechanism. Many companies use the award materials not to apply for the award, but as a guide to TQM and business excellence.

Whichever basic approach of TQM is adopted, it has been widely acknowledged that TQM implementation requires a culture change in the organisation. The organisation needs to develop a suitable TQM implementation and performance improvement strategy, by adopting a change model which is culturally feasible (Kekale and Kekale, 1995). Whittle *et al* (1992) argued that the TQM implementation process is iterative, and that after the company has implemented one approach to TQM on for some time it is difficult to maintain or improve performance. Diminishing returns tend to make the approach become redundant. They propose an interesting and useful framework, based on fundamental culture change concepts, described here as the ‘Sheffield TQM Model’. A detailed description of the model is given in Chapter 7 as this model was used as a theoretical framework in the TQM study in Thailand.

### **2.2.5 Research on quality management**

A substantial amount of research on quality management has been carried out in recent years. Since the area is broad and covers many topics, not all of which are closely related to this study, it is not practical or necessary to review all of this work. This section identifies recent quality management research which is relevant to this thesis, in order to identify the extent to which quality management has developed in terms of research perspectives, approaches and outputs. However, it should be noted that a number of other studies are specifically reviewed and cited in other sections throughout the thesis wherever appropriate.

---



It can be suggested that research perspectives be classified into two broad categories. The first category includes conceptual research studies which attempt to develop new conceptual ideas and fill gaps in knowledge and understanding relating to quality management. For example, Mohd Zain (1993) proposed a method of measuring to determine the quality position of an organisation, and Kehoe (1996b) extended this study using the time dimension with respect to the development of quality activities in an organisation. Quality implementation is the focus of research in the second category. The researchers typically try to understand the complexities of various quality concepts and theories, then identify how those can be best applied and used in an organisation. Within the last decade, there are many doctoral investigations that fall into this category, such as those by Mann (1992), Black (1994), Thiagarajan (1996), Adebajo (1997) and Najmi (1998). As described in Chapter 1, the current research has examined the development and implementation of quality management in Thailand. Hence, it belongs primarily to the second category. However, the basic quality system standard in the TFQSS study (Chapter 7) could perhaps be considered as belonging in the conceptual development area.

There are many approaches that can be used in research on quality management. Gill and Johnson (1991) state that the main approaches to management research are experimental research design, action research, survey research, and ethnography. According to Flynn (1990), operations management research can be carried out using either traditional mathematical formulation and simulation approach or empirical approach. Most research on

---

quality management that the author reviewed has employed an empirical approach, many of the approaches combining qualitative and quantitative methods. Survey-based approaches are generally popular. This approach was used by many researchers, for example Mann (1992), Mohd Zain (1993), Black (1994) and Hassan (1996). As the objectives of the current research were extensive, the study was carried out using a combination of research methodologies as described in Section 1.3.1.

Quality management research usually aims to provide outputs which are useful to both academics and practitioners. Theoretical frameworks and models of implementation are popular research outputs, especially in doctoral research. Najmi (1998) developed a framework to assist in the development of quality for the ‘post-ISO 9000 organisation’. Abdul Rahman (1993) proposed a model to capture the cost of quality incurred in construction projects. Mann (1992), Black (1994), Longbottom (1995) and Thiagarajan (1996) have all proposed frameworks to assist in TQM implementation, the last making a study of Malaysian practice. However, as described in Section 2.5, quality management research based specifically on studies in developing countries is still relatively rare. Different circumstances, environment and culture prevail in developed countries. Hence establishing an overall picture of quality management in a developing country like Thailand is considered a valuable output of this study.

---

### **2.3 The ISO 9000 series of quality systems standards**

There is no doubt that the ISO 9000 series of quality systems standards is well known and accepted internationally. Up to the end of 1997, more than 226,000 ISO 9000 certificates had been awarded in 129 countries. This number was an increase of nearly forty percent over the end of 1996 when the total of certificates was approximately 162,000 in 116 countries (ISO, 1997). The results from the seventh cycle of the ISO survey (ISO, 1997), outlined in Table 2-4, indicate that Europe took over the highest share of ISO 9000 certified organisations in the world from the UK by the end of 1996. The Far Eastern countries, climbing from fifth in 1993 to third in 1996, have also shown great industrial interest in the ISO 9000 certification process. The progress of the ISO 9000 in developing countries is also mentioned in section 2.5 and more details of ISO 9000 in Thailand, in particular, are provided in Chapter 3.

The background to the ISO 9000 series and its context including requirements are well documented elsewhere (see for example Owen *et al*, 1994; Ho, 1995; Harrington & Mathers, 1997). This section aims to discuss and review the relevant literature concerning the concept of ISO 9000 quality systems and their future, research concerning the standards including criticisms which have been aimed at them.



**Table 2-4 The ISO survey of ISO 9000 certificates awarded worldwide**

Regional share (%)	Jan. 1993	Sept. 1993	Jun. 1994	Mar. 1995	Dec. 1995	Dec. 1996	Dec. 1997
Europe (UK excluded)	16.2	20.8	26.4	29.2	31.4	34.9	38.5
UK	66.7	60.3	52.3	46.3	41.3	32.6	24.7
Far East Countries	2.4	3.4	4.3	6.2	7.2	11.3	13.6
North America	4.3	5.6	6.9	7.7	8.1	10.4	11.0
Australia/New- Zealand	6.6	6.8	6.5	6.8	8.2	5.8	5.6
Africa/West Asia	3.4	2.7	2.6	2.7	2.6	3.7	4.1
Central and South Americas	0.1	0.3	0.6	0.7	0.9	1.0	1.3

### 2.3.1 The concept of ISO 9000 and future trends

The ISO 9000 series of quality systems standards appeared in the late 1980s. In fact, the concept of quality systems standards was established almost three decades before when MIL-Q-9858A was released in 1959 by the US Department of Defence. Most of the requirements of ISO 9001-1994 are similar to the ones in MIL-Q-9858A in those early days, except that some elements required by MIL-Q-9858A to maintain a very high level of quality management practice necessary for the military are not required by ISO 9001 (Harrington and Mathers, 1997). Quality management system requirements were well defined and were described by Feigenbaum as follow:

A quality system is the agreed companywide and plantwide operating work structure, documented in effective, integrated technical and managerial procedures, for guiding the co-ordinated actions of the work force, the machines, and the

---

information of the company and plant in the best and most practical ways to assure customer quality satisfaction and economical costs of quality (Feigenbaum, 1991, p 78).

Feigenbaum (1991) also comments that the ISO 9000 series, which he considers is a minimum entry-level quality concept, points toward a broad and systematic approach to quality achievement, and taken together with four management fundamentals of total quality (described in section 2.2.3) is the key to make quality the best investment in corporate competitiveness.

The definition of a quality system which is defined in ISO 8402 is “the organisational structure, procedures, processes, and resources needed to implement quality management”. Compared to Feigenbaum’s definition, ISO 8402 provides a broader and looser meaning. However, both definitions demonstrate that a quality system is important for quality management and provides formal and structural arrangements for an organisation in order to produce products and services conforming to specifications and in accordance with customer requirements. As discussed in Section 2.2.3, one of the main components of a framework of quality management as proposed by various eminent authors is “systems”. The ISO 9000 standards represent the most successful type of quality system, worldwide.

The ISO 9000 series standards, like other ISO standards which are periodically reviewed to ensure that they remain state-of-the-art, is currently in the process of revision. The year 2000 revisions of the ISO 9000 series are expected to be published in the fourth quarter of 2000 (ISO, 1999). The new version will consist of ISO 9000 which gives quality fundamentals and

---



---

vocabulary; ISO 9001 which gives quality management system requirements and consolidates the current ISO 9001/2/3 into a single document; and ISO 9004 which provides guidelines for performance improvement. The ISO 9000 year 2000 revisions has been restructured and now somewhat resembles the business excellence models such as Malcolm Baldrige National Quality Award (MBNQA) and the European Quality Award. Twenty elements in ISO 9000-1994 are substituted by five broader requirements in the year 2000 version. It appears that the new revision has also moved closer to the concept of quality improvement which is a key aspect of TQM

### **2.3.2 Research on ISO 9000**

In recent years, widespread adoption of ISO 9000 has been accompanied by increasingly attention in the literature (see for example Srivastav, 1994; Brumm, 1995; Cater and Pasqualone, 1995; Goult, 1995; IQA, 1995; Dedhia, 1996; Hind, 1996; Motwani *et al*, 1996; Tsiakals and Cianfrani, 1996 and Crowe *et al*, 1998). Most of the ISO 9000-related literature has been written by two types of authors. One is a group of practitioners and consultants (such as Fabien, 1993; Lupear, 1993; Heisey, 1994; Alcorn, 1995; French and Eltringham, 1995; Grenville and Turnbull, 1995; Yaacov, 1995; Peach, 1996 and Schottmiller, 1996). The others are academics or researchers from quality and operational backgrounds. The first group generally gives positive descriptions, which are largely prescriptive and anecdotal. The second group produces more systematic and critical work. Empirical studies on ISO 9000, mostly using survey methods, include the experience of ISO 9000 certification, the reasons to pursue ISO 9000, the costs

---



---

and benefits of ISO 9000, and the effects of certification on an organisation (Wenmoth and Dobbin, 1994; Brown and Van der Wiele, 1995; Taylor, 1995; Buttle, 1996; Carlsson and Carlsson, 1996; Mallak *et al*, 1997; Jones *et al*, 1997 and Brown *et al*, 1998).

In a survey conducted by the Manchester Business School, which is advanced as “the most comprehensive, omni-sectoral UK study” into the ISO 9000 standards, Buttle (1996) identified twenty-three benefits as results from ISO 9000 registration and presented to participating companies to determine their experience of, and the value they put on each one. The results from factor analysis showed that the benefits which companies valued are profitability improvement; process improvement and marketing opportunities. Raising awareness of quality throughout the organisation was reported as one of great benefits from the ISO 9000 certification process (Brown and Van der Wiele, 1995). Studies specifically concerning issues surrounding ISO 9000 in developing countries are reviewed later in Section 2.5.

### **2.3.3 Criticisms of ISO 9000**

As evidenced in the ISO survey by the rapid increase in the number of registered companies worldwide, it is clear that the ISO 9000 standards have enjoyed much success. However, along with the growth in certification to the standards, there are criticisms concerning the benefits of ISO 9000 and its value as a route to quality improvement.

Seddon (1997) argued that ISO 9000 belonged to a “traditional command and control” management thinking, and was based on a bureaucratic

---

---

control standard that was used in the Second World War to control suppliers who supplied the government with munitions. He is strongly opposed to ISO 9000 and gave ten arguments against ISO 9000, which are as follows:

1. ISO 9000 could make things worse for customers because people in a certified organisation might stick to contract review procedures without considering customer's requirements.
2. ISO 9000 emphasises documentation and organisations were audited according to documents established in the system. The argument was that the companies could get ISO 9000 registration with relatively poor performance, but with loads of documentation.
3. The propose of documentation in ISO 9000 systems was to establish "what we say we do" and to allow audit process to determine "whether we do it". This was a way to control work, but not the way for good quality. Quality is about improvement.
4. Implementing ISO 9000 did not mean improving performance. ISO 9000 could become viewed as "extra work" in many organisations.
5. The standards depended too much on people's, particularly assessors' interpretation of quality.
6. ISO 9000 led to sub-optimisation because optimisation was beyond the scope of the requirements.
7. Because of external control (external assessors), people tended to pay less attention to those things which were controlled by ISO 9000.
8. ISO 9000 belonged to "the inspection school". This discouraged managers from learning about the theory of variation, which was profoundly more valuable as a means to performance improvement.



9. ISO 9000 failed to foster good customer-supplier relations, if the suppliers were forced to be certified instead of working together with partnership and co-operation.
10. ISO 9000 represents traditional “command and control” management thinking, which began in mass-production systems. It was argued that changing the way of thinking about management was the key to performance improvement. ISO 9000 therefore prevented managers to think differently.

In short, Seddon (1997) contended that ISO 9000 was not at all about quality since it was not focussed on a culture of quality improvement. Other opinions against ISO 9000 are that implementing ISO 9000 requires company resources and leads to high cost, especially for small company (Fabien, 1993 and Tsiotras and Gotzamani, 1996) and that introducing ISO 9000 makes undue demands on the time of individuals and produces a large volume of paperwork (Brown and Van der Wiele, 1995 and McTeer and Dale, 1996). Litigation problems concerning product safety; not addressing continuous improvement; costs for certification process; and difficulty in maintaining ISO certification are listed as major criticisms by Motwani *et al* (1996). However, these authors try to distinguish between criticisms and misconceptions of the standard.

Other authors (see for example McLachlan, 1996; Struebing, 1996 and Ng, 1998) also suggest that many criticisms of the ISO 9000 standards are unjustified and arise from misunderstanding of the purposes and intent of the standards. Ng (1998) warns practitioners that there are many misconceptions about ISO 9000 to be aware of; for example certification is the purpose and



---

the end of the quality journey, ISO 9000 guarantees profit or means zero defects; ISO 9000 is product certification standard and it can cure anything.

From a Japanese viewpoint (Kume, 1993), ISO 9000 is constructed from the purchaser's standpoint whereas Japanese quality activities originate from the supplier's standpoint. However, Japan can get many advantages from the ISO 9000 standards by reassessing Japanese quality management in comparison with the standards and reconstructing it on the firm foundation which the standards provides Japanese quality management will then be raised to even higher levels internationally. On the other hand, the author advises that the ISO standards should be carefully used in order to achieve better and more reliable quality management.

Will a certification system based on the ISO standards really improve quality worldwide, or will it simply result in mountains of useless paperwork? This is a concern. A system is simply a means to an end, and however excellent it may be in itself, it will do more harm than good if misapplied. We must keep this fact constantly in mind when applying the ISO standards. Using them merely for the propose of gaining certification will promote a ritualized form of quality management. We must view the system as providing us with opportunities to review our maintenance and improvement of quality. (Kume, 1993, p. 87)

The criticisms mentioned above are certainly, in some points, worth being considered. The ISO 9000 standards does provide an assurance that a supplier will consistently supply product with same specifications that it promises. However, it can be the worst product quality (a 'concrete lifejacket' as Tom Peters once famously claimed) in the market, and a company who has an ISO 9000 series certificate may have high defective rate in their production,

---

---

leading to high quality costs - which are not covered by the standard. Hence, it is the responsibility of practitioners who wishes to implement ISO 9000 to correctly understand the standards and apply these tools effectively.

It is worth also considering the criticism of the complexity of the ISO 9000 standards for smaller companies. As a response, some countries have developed lower-level standards. In New Zealand, the Q-Base (Telarc, 1996) approach developed by Telarc, a New Zealand accreditation and certification body, was established as an entry-level quality systems standard. Similarly, the Irish Quality Association launched the Q-Mark standard in the 1980s as the basic standard for non-exporting companies. The issue on the foundation level of quality systems standard will be discussed in more details in Chapter 8.

#### **2.4 Japanese approaches to quality**

Despite recent setbacks, the Japanese economic miracle over recent decades continue to be much discussed. It widely is agreed that the dominant factor in the success of Japan in world markets is quality (Lascelles and Dale, 1993). In the early post-war period, Japanese quality had a reputation which was considered poor. But today “Made in Japan” is a mark of superior quality. A great transformation of Japanese goods occurred from the ‘cheap and shoddy’ product image to the “superior quality and reliability” one within a few years in the 1960s. Many authors (see for example, Garvin, 1988; Oliver and Wilkinson, 1992; and Lascelles and Dale, 1993) consider the



Japanese approach to quality management worthy of significant analysis and comment.

There are many manufacturing practices which are labelled as “Japanese”. Most of them relate to quality and the control of processes. Quality for the Japanese manufacturer is not only linked to customer satisfaction but also to the efficiency of the production process. In Japan, It is believed that maintenance of high standards of quality results in cost reduction (Oliver and Wilkinson, 1992). Westbrook (1995) stresses that there are still lessons of quality to be learned from Japan. Japanese quality practices have also been very popular in Thailand in the past decade (Tabucanon, 1993). The following sections are devoted to a review of some well-known Japanese methods, some of which have been widely accepted in Western as well as developing countries such as Thailand.

#### **2.4.1 Quality control circles (QCCs)**

The principle behind QCCs is a small group of company workers and a supervisor or facilitator who meet voluntarily to carry out various activities in order to solve quality problems relating to their work (Kondo, 1995). The concept of QCCs was developed in Japan in the 1960s and has been developed into a national issue. The Union of Japanese Scientists and Engineers (JUSE) (which is a private organisation established in 1946 with the aim of studying foreign technology that might be applied to improve the level of Japanese industrial technology) plays a very important role in the promotion of QCCs. The first QCCs conventions in Japan were established in 1963, since when up

---



to 200 conferences per year have been organised in Japan. There are over one million QCCs registered with JUSE (Ho, 1995). The main objectives of QCCs (Kondo, 1995) are to:

- improve the management abilities of front-line supervisors through self-development;
- increase quality awareness and problem-solving consciousness;
- enthuse employees including front-line workers with their full participation and to ensure that quality control and improvement are practised assiduously on the shop floor
- function as a “nucleus” for QC activities as part of a CWQC programme (described in section 2.4.5) to establish control in the workplace and to assure quality.

The foundation of successful QCCs is the training of all QCCs members. The basic knowledge that QCCs members must acquire is the application of problem solving techniques such as the seven QC tools.

#### **2.4.2 The seven QC tools and the seven management tools**

Data are required, together with an analysis of these data, as a basis for quality improvement work. In Japan, it was realised that everyone including front line operators in an organisation had to participate in the improvement programme, and that the tools which were to be used had to be simple and effective. The seven QC tools were put together by Ishikawa, among others. These tools have been taught to workers and supervisors in Japanese industry who have used them systematically for problem solving since the beginning of

---

---

the 1960s (Bergman and Klefsjo, 1994). The basic seven QC tools (Ishikawa, 1988) are as follows:

1. Pareto diagrams.
2. Cause and effect diagrams (or Ishikawa diagrams).
3. The idea of stratification.
4. Check sheets.
5. Histograms and frequency distributions.
6. Scatter diagrams.
7. Graphs and control charts.

The seven QC tools are at the heart of the QCCs programme since they are useful tools to support the quality improvement programme of an organisation. The common characteristic of the seven QC tools is that they are all visual, in the form of charts, graphs, or diagrams. Ishikawa (1988) contends that ninety five percent of a company's problems can be solved using these simple seven QC tools.

Most of the QC tools are aimed at numerical data analysis. Facts, however, are not always numerical in nature. Hence, JUSE compiled other tools from various sciences such as behavioural science, operational analysis, optimisation theory and statistics. These are called “the seven management and planning (MP) tools” or sometimes “the seven new QC tools” (Bergman and Klefsjo, 1994). The seven MP tools consist of:

1. Affinity diagrams
2. Relation diagrams
3. Tree diagrams
4. Matrix diagrams
5. Matrix data analysis
6. Process decision programme charts
7. Arrow diagrams

### **2.4.3 5-S practice**

5-S practice is a technique employed to establish and maintain a high-quality environment in an organisation. The name stands for five Japanese words: Seiri, Seiton, Seiso, Seiketsu and Shitsuke (Ho, 1995). Their meanings and typical examples are shown in Table 2-5. The logic of the 5-S practice is that basic requirements for producing quality products and services with high productivity and with little or no waste are the organisation, neatness, cleanliness, standardisation and discipline at the workplace. The 5-S technique has been widely used in Japan. The Japanese practitioners consider 5-S useful not only for improving their physical environment but also for improving their thinking processes.



**Table 2-5 5-S meanings and typical examples (Ho, 1995)**

Japanese	English	Meaning	Typical example
<b>Seiri</b>	<b>Structure</b>	Organisation	Throw away rubbish
<b>Seiton</b>	<b>Systematise</b>	Neatness	30-second retrieval of a document
<b>Seiso</b>	<b>Sanitise</b>	Cleaning	Individual cleaning responsibility
<b>Seiketsu</b>	<b>Standardise</b>	Standardisation	Transparency of storage
<b>Shitsuke</b>	<b>Self-discipline</b>	Discipline	Do 5-S daily

#### **2.4.4 Suggestion systems**

In successful Japanese companies, for example Toyota, most employees are also active in quality improvement work through company suggestion systems. The concept of suggestion systems is to stimulate employees to contribute their knowledge and experience by providing their advice to improve their work. There is no perfect organisation since there Muda (wastefulness), Muri (overburden) and Mura (unevenness) occur in every workplace and cannot be solved by machine. Only careful employees can discover deficiencies and then correct or improve them (Toyosawa, 1988). The objectives of suggestion systems are to improve the power to work and individual abilities; to promote friendly and healthy human relations among employees and to vitalise activities; and to improve the company's structure and operations (Lascelles and Dale, 1993).

Toyota introduced a suggestion system among their employees in the 1950s. The system did not work properly for the first few years but more

---

recently the system has become very efficient. The reasons why the suggestion system in Toyota is successful are that all suggestions are rapidly responded to by management; that they have a reward system for good suggestions and that management look seriously at the submitted suggestions and actually make use of the improvement ideas (Bergman and Klefsjo, 1994).

#### **2.4.5 Company-wide quality control (CWQC)**

The Japanese approach to quality management has been extended to become a concept and philosophy after the application of statistical quality control was introduced by American gurus such as Deming and Juran. It has been realised that the application of SQC techniques limited to production and inspection functions is not sufficient to achieve customer satisfaction, which is the main objective of quality control. The Japanese recognised that it is necessary not only to put more emphasis on the processes that take place before production and inspection, but also to apply the QC approach to those that take place afterward (Kondo, 1995). Therefore the concept of control evolved from SQC to become CWQC. Ishikawa sees CWQC as implying that quality does not only mean the quality of product, but also after sales service, quality of management, the company itself and indeed human life (DTI, 1991).

The CWQC concept has been associated with the term Total Quality Control (TQC) and later with Total Quality Management (TQM) in the West (Garvin, 1988; Oliver and Wilkinson, 1992; Oakland, 1993; Kondo, 1995; and Ho, 1995). However, Kondo (1995) argues that CWQC has two principal features which distinguish it from TQC and TQM. The first is the wide

---



coverage of the QC activities which involves a deep awareness of the need for teamwork not only in production and inspection process, but also in every other area in an organisation. The second principal which makes Japanese CWQC different from Feigenbaum's TQC is total employee participation in QC and ancillary activities. According to Garvin (1988), CWQC consists of four elements: the involvement of all functions apart from manufacturing (he indicates that this is an idea taken directly from Feigenbaum); the participation of employees at all levels; the goal of continuous improvement; and careful attention to customer's definition of quality.

The aim of CWQC is to create a tightly integrated organisation, with efficient usage of resources for price-competitiveness, but simultaneously flexible enough to respond to customer requirements (Oliver and Wilkinson, 1992). In Schonberger's (1982) viewpoint, Japanese TQC is a 'fundamental production function', along with many other Japanese manufacturing techniques, such as QCCs, JIT and tight in-process controls.

#### **2.4.6 Just-in-Time (JIT)**

Just-in-Time (JIT), among others, is a Japanese manufacturing approach which has caught Western interest (Oliver and Wilkinson, 1992). There are various views of the origins of the JIT concept. According to Schonberger (1982), it was first applied in the Japanese shipbuilding industry in the late 1950s or early 1960s and extended to the Japanese steel industry. Due to excess capacity, shipbuilders were able to get steel delivered virtually on demand, and consequently dropped their stocks down from about one

---



---

month's requirements to three days. Other sources suggest that JIT originated at Toyota (Voss, 1987 and Logothetis, 1992). According to Voss (1987), Toyota began experimenting with many approaches to manufacturing management, including the JIT concept, in the 1960s. JIT was later extended to suppliers and the sales department. By the mid 1970s, it had become widely known in Japan as the "Toyota Manufacturing System".

The principle aim of JIT is "to operate or produce to meet the requirements of the customers exactly, without waste, immediately on demand" (Oakland, 1993). While some authors regard JIT as a modern management principle (Voss, 1988; Oliver and Wilkinson, 1992; Lascelles and Dale, 1993 and Oakland, 1993), others simply consider it as only the kanban system (Logothetis, 1992 and Kolarik, 1995).

#### **2.4.7 Total productive maintenance (TPM)**

Total Productive Maintenance (TPM) was defined by the Japan Institute of Plant Maintenance (JIPM) in 1971 as "a system of maintenance covering the entire life of the equipment in every division including planning, manufacturing and maintenance" (Ho, 1995). Its objective is to increase the productivity of every piece of equipment. The philosophy behind it is based on autonomous maintenance activities to maximise equipment effectiveness, by the operator. It is a development of Preventive Maintenance (PM) in which activities are planned to maintain and prevent equipment from breaking down. Here the maintenance department is responsible for all equipment used in factory. In the concept of TPM, however, the maintenance department must

---

---

work with the production teams and also others such as the planning department, human resources development, etc. who are also responsible for keeping equipment in good condition. Everyone, through TPM co-operates to proactively maintain equipment in order to increase the productivity of plant and ultimately the company's profitability. The 5-S practice is also essential in activity supplementing TPM. Lascelles and Dale (1993) provide an example of the three-year TPM programme in a battery manufacturing company which consists of seven key steps as follows:

1. initial cleaning.
2. counter-measures at the source of problems.
3. cleaning and lubrication standards.
4. general inspection.
5. autonomous inspection.
6. orderliness and tidiness.
7. full autonomous maintenance.

A TPM sticker is issued and placed on a machine after each TPM step has been achieved. Employees of the company were trained on the TPM programme. TPM efficiency improvements resulted in a 20% increase in machine performance for the battery plate making line and 100% increase on the battery assembly line.

### 2.4.8 Kaizen

As literal translation from the Japanese of the word Kaizen means “change to the better” (Bergman and Klefsjo, 1994). It has also been equated with the term “continuous improvement” in English (Ho, 1995 and Kehoe, 1996a). The kaizen philosophy aims at developing improvements in all areas of the business on a continuous basis. It is based on people’s commitment and participation. Practising kaizen can be done through teamwork such as QCCs and through suggestion systems. Among the most important methods of kaizen are the seven QC tools. According to Kehoe (1996a), Japanese kaizen is different from Western innovation as shown in Table 2-6. Improving performance through innovation is mainly carried out by management who want to find new ways of doing things in order to gain advantage over competitors. Business process re-engineering and investment in new manufacturing technologies are typical approaches employed for innovation.

**Table 2-6 Kaizen vs. Innovation (from Kehoe, 1996a)**

Kaizen characteristics	Innovation characteristics
A large number of incremental improvements.	Infrequent, large-scale advance in performance.
Employee involvement through teamwork.	Management driven.
Company-wide over a long period of time.	Technology based.
Originating from Japan	Originating from USA.



---

## **2.5 Quality management in developing countries**

Studies of quality management in developing and newly industrialised countries (NICs), which include Singapore, Hong Kong, Korea and Taiwan, can help provide a perspective for this investigation. The literature in this area has until recently been relatively sparse compared with the many detailed studies of US, Japanese and European practice, but a number of developmental and comparative studies have now become available. Thai history and traditional culture has distinctive features which set it apart from those of its neighbours, and which influence the culture in the workplace. However other South and East Asian countries are of interest from a comparative viewpoint, as they share a number of important influences. In particular the researcher considers that geographical proximity and economic involvement with Japan, trends of success and failure in economic and industrial development, cultural traditions and regional business practices are significant issues for quality management. A brief survey of quality management and its background in several neighbouring developing countries are presented in the following sections.

### **2.5.1 Singapore**

Singapore is a small country which has taken a disciplined strategic approach to achieving manufacturing success, which extends to the quality area. Singapore companies have also adopted ISO 9000 series standards to a much greater extent than their Thai counterparts. The ISO 9000 certification system in Singapore is well established. The Singapore Productivity and

Standards Board (PSB) is the leading organisation for standards and conformance through its programmes in metrology, standardisation, laboratory accreditation, certification, testing and evaluation services (Hong, 1996). Since it launched its ISO 9000 certification scheme ten years ago, around 2,100 companies had been certified to ISO 9001/2 by the end of 1997, and the PSB has issued the highest number of ISO 9000 certificates to Singapore companies (PSB, 1999). In order to establish Singapore as a country committed to world-class business excellence, Singapore quality award (SQA) framework which is very similar to the US Malcolm Baldrige National Quality Award was established in 1994. The SQA model was used to developing the measuring instrument in order to measure the level of quality management practices and to identify the strengths and areas for improvement of the organisations (Quazi *et al*, 1998).

From results of a survey, Quazi and Padibjo (1998) describe the progress from ISO 9000 standards to TQM implementation among SMEs in Singapore, assisted by a government initiative. Their research showed that ISO 9000 can be a stepping stone toward TQM implementation.

### **2.5.2 Hong Kong**

The global trend towards better quality management has been realised in Hong Kong since the 1990s (Chin, 1996). The Hong Kong government has initiated many activities to support local companies in pursuit of high quality production. Earlier, the Standards and Calibration Laboratory was established in 1984 to maintain standards of measurement and provide calibration

---



---

services. In 1985, the Hong Kong Laboratory Accreditation Scheme was launched to encourage the upgrade of management and testing standards. Further, the Products Standards Information Bureau is responsible for maintaining a collection of more than 80,000 national standards. In 1989, the Hong Kong government has launched its ISO 9000 certification scheme. The Hong Kong Quality Assurance Agency (HKQAA) was established in 1990 as a national certification body governed by the Hong Kong Assurance Council. HKQAA has registered more than 1,300 companies (HKQAA, 1999).

Lee (1993) reports the finding of a survey on the use of quality management techniques in Hong Kong industry and its investment in China. It was found that the attitude of Hong Kong industry towards quality management concepts, especially ISO 9000 was positive. Moreover, TQM was frequently adopted after a company obtained ISO 9000 certification (Lee, 1998). However, the research carried out by Chiu (1998) illustrated the problems of involvement in a TQM programme in ethnic Chinese firms located in Hong Kong. The author stated that some characteristics of the Chinese culture such as face saving, low trust, conflict avoidance, high power distance, status consciousness, and “social loafing” could make the job of the facilitating teamwork and total employee involvement in TQM programmes more difficult. In this regard it should be noted that ethnic Chinese operate a large number of businesses throughout the region.

According to Lee (1995), the results from an ISO 9000 survey of Hong Kong industry showed that the companies which did not have a formal quality system and management practice before obtaining ISO 9000 certification

---



tended to have the following characteristics: employ additional staff to assist the ISO 9000 implementation, have extreme changes in organisations, involve senior management only in the ISO 9000 project, quality policy seems not to have a significant effect on the company, do not gain much benefits such as reducing waste, improving efficiency, and relationship with sub-contractors, looser control of sub-contractors' quality, have more problems with quality system maintenance, and less expectation on developing the system to TQM.

### **2.5.3 Taiwan**

From Taiwan, in an interesting case study (Chen and Lu, 1998) examined a single local company implementing TQM, and identified Taiwanese cultural issues, particularly Confucian tenets as important factors in the process. The authors also provided the background to quality management in Taiwan. Both government and industry in Taiwan have long striven for quality management. In 1967, the concept of quality control circle (QCC) was introduced and became popular in industry. TQM was first introduced around 1980 and became widely accepted after 1987. ISO 9000 certification is also well known. In 1989, the Ministry of Economic Affairs instituted the national quality award to encourage TQM implementation.

According to Jeng (1998), there were over 1,200 companies, in Taiwan, that were certified to ISO 9000. He conducted a survey to evaluate the performance of the organisations that have registered to ISO 9000. The result showed that seventy percent of the companies that achieved ISO 9000 certification had improved their performance. Another empirical research

---

project, reported by Huarng (1998), indicated that ISO 9000 implementation can help Taiwanese SMEs gain benefits in internationalisation, quality improvement, sales enhancement, and cost reduction. The author confirmed that implementing ISO 9000 with particular regard to TQM concepts and employee involvement could result in significant benefits for SMEs.

In another paper Chen (1997), reporting on a study of the human aspects of TQM implementation in Taiwan, presents a quantitative analysis based on a questionnaire and interviews, which indicates that the subsidiaries of Japanese and US companies perform more effectively in this area than do locally owned companies. Lin (1998), using a survey instrument, found some striking relationship between quality management practices and organisational climate. He reported that organisations who have high quality-tendency had loose organisational structure, less emphasis on bureaucracy and are more competitive.

#### **2.5.4 Korea**

In his paper, Kang, C.W. (1996) describes the status of quality management in Korea. At national level, since 1960s Korean government has carried out many activities to set up an infrastructure for quality. For example, a standardisation system was introduced and industrial standardisation was given a legal basis in 1961. The Korean Standards Association (KSA) was established in 1962 in order to certify products made in the country in accordance with the Korean Industrial Standards Law. The Industrial Advancement Administration (IAA), under the Ministry of Commerce and

---



---

Industry, has been actively involved in promoting quality control concept to industry since 1973. The IAA also adopted the ISO 9000 standards as Korean Industrial standards in 1992 and acts as an accreditation body to accredit certification bodies and training organisations in Korea. There were over one thousand companies that have been certified to ISO 9001 or 9002 by domestic and foreign certification bodies by February 1996 (Kang, I.K., 1996). Moreover, the IAA established the Korean quality management award system in 1975 in order to encourage and promote quality concepts in Korean industry.

### **2.5.5 Malaysia**

Quality management is relatively new to Malaysia (Idris *et al*, 1996). However, the Standards and Industrial Research Institute of Malaysia (SIRIM) has played a very active role in promoting quality issues. In 1987, SIRIM launched the quality system assessment and registration scheme. Consequently, ISO 9000 standards have been well known since the early 1990s. At present SIRIM has registered over 1,000 Malaysian companies (SIRIM, 1999). According to Ali (1994), the adoption of ISO 9000 has taken the quality movement in Malaysian industry to a higher level.

Idris *et al* (1996) conducted a survey of Malaysian manufacturing companies already registered to ISO 9000, with a view to examining their status as regards TQM implementation. Less than a third of the responding companies claimed to 'have TQM', but there was a strong minority claiming to have made substantial progress towards total quality practices. These



---

authors also describe the Malaysian SIRIM model of total quality training for a company, which is multi-step process involving the adoption of such practices as a quality improvement process, 5-S, Quality Control Circles (QCC) and TPM (Total Productive Maintenance). In their consequent study (Idris *et al*, 1997), the authors developed a conceptual model called SMET (Small and Medium Enterprises TQM Implementation) based on SIRIM model. They reported that all key activities in SMET model (5-S, Production Planning & Control, QCC, ISO 9000, TPM and TQM) were significant to business performance of SMEs. They also concluded that SMET model was workable and practical for implementing TQM.

Thiagarajan (1996) conducted an empirical study of TQM and proposed a framework of generic application for Malaysian-based organisations. He presented four critical categories for TQM implementation which were institute leadership, maximise internal stakeholders involvement, manage by customer-driven processes and adopt continuous improvement. He also concluded that the critical quality processes in Malaysian companies were similar to those found in the West countries.

Kaye and Dyason (1997) report on a comparative action-research study of quality management in Malaysia and the UK. They comment particularly on the cultural clash between traditional Malaysian managers who 'are locked into traditional autocratic management styles' and expatriate senior managers, particularly from Japan. Like most Thai companies, the Malaysian companies studied here perceived ISO 9000 as the final goal. However there was evidence that Malaysian companies made more systematic use of quantitative

---

---

quality management tools to control key processes than did the UK companies studied. In addition the Malaysian companies were assessed by these authors, using a questionnaire, to be more focused on strategic quality orientation and continuous improvement than their Western counterparts.

According to Hassan (1996), the Malaysian national social and economic objectives seem to have significant influence over the aspects of improvement of organisations which are emphasised in industry.

### **2.5.6 India**

Despite the vast size of the country, very little published information seems to be available on quality management in India. Here, where the large domestic market was long protected from international competition, the introduction of modern quality management practices was limited mainly to multinational companies. For example, Glaxo India which is the largest pharmaceutical company in India, initiated “the Glaxo Wellcome Excellence Process” as its continuous improvement programme (Blythe *et al*, 1997). With moves to liberalise the Indian economy, many more companies have felt the need to adopt ISO 9000 series standards or implement TQM. The general reputation of quality management has not been assisted by a proliferation of unregulated and unaccredited ISO 9000 ‘certification bodies’. As regards TQM, Indian companies have adopted diverse models and TQM doctrines, and quality award schemes have been introduced to raise the profile of quality in Indian business. (Ahluwalia, 1997).



---

### 2.5.7 People's Republic of China

In People's Republic of China, quality activity has begun since 1957 when Yuanzhang (1994) founded the first research group on quality control and provided training courses on SQC to industry. However, at that time SQC was not applied in industrial enterprises. When PRC started its more open policy and moved from an absolute planned economy towards a market economy, it has been realised that quality management could not be neglected.

The ISO 9000 standards were formally issued as national standards in 1993. There were more than 4,000 organisations in PRC certified by the end of 1997 (Han, 1998). This author describes the development and characteristics of PRC's ISO 9000 quality system certification. There were three stages: a preparatory stage; a development stage; and finally the stage of 'going to the world'. There has been a considerable effort in the PRC to promote ISO 9000 and encourage companies to implement the standards, but several problems have been encountered. Some company working methods do not comply with the requirements of the standards. Companies also have difficulty dealing with the multiple activities of supervision and certification. The author summarised that there still was a lot of work needed to improve the fairness, effectiveness and authority of the certification process.

Barad (1995), in a comparative study of PRC and Australian quality management practices, identified distinctive differences in rationale, objectives and the scope and practice of improvement programmes. The PRC practices exhibited a greater similarity to Japanese approaches. One



---

significant difference was in the use of quality costs, which were reported regularly in all the PRC enterprises studied.

Substantial South-East Asian countries such as Indonesia and the Philippines show very little evidence of efforts or progress in quality management. At national level, both of them do have national standards organisations. The National Standardization Agency of Indonesia (BSN) has been established to be responsible for developing standardisation in Indonesia, which include metrology, standards, testing and quality (BSN, 1999). The Bureau of Product Standards (BPS) is the Philippines' national standards body, under the Department of Trade and Industry (BPS, 1999). However, published information regarding quality management in these two countries seems to be unavailable.

Vietnam, which recently started an open economic policy and encouraged foreigners' investment in their country, has a national standards body, named the 'Directorate for Standards and Quality (STAMEQ)'. The STAMEQ, in addition to its functions as a national standards body, also certifies companies in Vietnam. According to STAMEQ report (STAMEQ, 1999a), there are 20 companies which have been certified under the STAMEQ certification scheme, and another 24 companies by other certification bodies.

In summary, quality management in developing countries has been established and developed in much the same way as with developed countries in the West and Japan. At a national level, it is the duty of government to provoke quality activities within the country. According to Sanholm (1988),

---

---

national efforts for quality include standardisation; certification; export inspection; legislation; national promotion; education and training; external assistance; institutional infrastructure; and national quality control society. Those countries mentioned above including Thailand (which is described separately in Chapter 3) have embarked on a national quality journey and made effort to promote quality management in their countries. However, some of them have done a good job while others are still struggling.

## **2.6 Quality management and national traits**

There is as yet no firm conclusion on whether national culture has a great impact on quality management. However, there have been attempts to investigate the relationship between national culture and quality practices and also to undertake comparative study on quality management. According to the study on organisational culture reported by Hofstede *et al.* (1990), the values and practices of people in organisation may be influenced by corporate factors, task and industry factors, and national factors, and the degree of influence may vary from organisation to organisation. Juran (1993) has argued that there is no need to redesign a country's culture to create the disciplines of quality improvement. Concept of quality management should be able to be universally applied, as stated by Logothetis (1992).

This is the classic excuse of Western management for refusing to accept the principles and techniques that have made Japan an economic superpower. Particular problems might indeed be different, but the principles for solving them and for satisfying the customer are universal....National culture has nothing to do with it (Logothetis, 1992, p. 51).



---

On the other hand, Kano (1993) commented that one needs to take cultural issue into account when implementing quality management. However, he also emphasised that culture is not a barrier to quality management implementation.

Harrington (1996) carried out a three-year period international study to identify the national traits in TQM practices between North America, Europe (Germany) and Japan. The international key comparisons were strategic planning, design of new products and services, use of business process improvement tools, use of teams, use of improvement tools and quality assurance's role. He concluded that Japan seems to be changing focus from a team concept to an individual excellence approach, while North America and Germany still focus on team improvement. He also states that North America and Japan focus on business process improvement but Germany does not recognise that Japan has a significant advantage in this area.

In the study of quality management practices and performance in five countries: Australia; New Zealand; Hong Kong; Korea and Taiwan, Corbett *et al* (1998) conducted mail surveys of operations managers to find out how much agreement existed around quality practices and how similar was the performance being achieved. They reported that there were more divergence by countries from the region's mean scores on practices rather than on performance. Moreover, regression analysis found only one measure of performance, which is employee satisfaction with the company, which was significantly related to practice factors.



## **2.7 Summary**

This chapter has reviewed key issues concerning quality management in general as well as quality development in developing countries. The overview has shown that there is a vast array of literature on quality management. Quality management, from Taylorism to modern “Total” management of quality, has had a long and eventful history. It is obvious that apart from ‘hard’ aspects such as systems and tools, human resources which are the ‘soft’ side are not less important to quality improvement. As there are many definitions of quality and numerous approaches to management of quality, an organisation which wishes to embark on a quality journey has to understand the concepts and approaches which they can apply in order to ensure successful implementation. In one aspect, TQM might be described as a management philosophy which has been adopted by many organisations so as to compete in the global market. Some of them are successful and gain many benefits from their quality programme, while some others fail.

The ISO 9000 series of quality systems standards has also become a major issue since it came into the history of quality management. It represents a unique global phenomenon, and more than a hundred nations have adopted it as their national standards. However, the positive and negative effect of the standards has been the subject of much debate in recent years.

Since Japan has been leading other countries in the world market and it has been widely agreed that a key success factor is quality, Japanese approaches to quality management have been reviewed here. Some of the

---

Japanese approaches have been imported to Western countries, but in developing countries in Asia such as Thailand they are very significant.

Quality management is still in its infancy in many developing countries. Literature on quality management in the developing countries is a very scant resource, and the research on this subject needs more attention. This chapter has however examined recent studies from the most significant “Asian Tigers”.

In the next chapter, quality management in Thai industry is reviewed in order to provide background information to Thai industry and economics as well as quality development.

### **3. Quality management in Thai industry**

#### **3.1 Background to Thai manufacturing industry**

Before the 1960s, Thailand had an economy based on agriculture. The biggest income was from agriculture (Manarungsan, 1989). The manufacturing sector in those days processed agricultural products and local raw materials mainly to meet domestic demand. The agricultural share of Gross Domestic Product (GDP) was overtaken by that of manufacturing in 1985 (Warr, 1993). The growth rate of exports accelerated through 1980s, and the composition of these exports tended to change from commodities to manufactured products. The proportion of agricultural exports decreased from 83 % in 1961 to 62 % and 28 % in 1971 and 1987 respectively, while manufactured exports increased from only 2.4 % in 1961 to 10 % in 1971 and 63 % in 1987 (Tambunlertchai, 1993). Manufacturing has made the largest contribution to the economy in the past three decades. The manufacturing sector, which was initially geared towards import-substitution, became more export-oriented. The textile industry was the most important foreign exchange earner in the export market, it replaced rice which had been the most significant export earner since Thailand first entered into foreign trade in the mid-nineteenth century. Thailand was one of the economies (other include South Korea, Taiwan, Singapore, Hong Kong, Malaysia, Indonesia and China)

---



---

which were among the world's thirteen most successful at raising real incomes in 1965-1990 (Rohwer, 1995). In short, Thailand manufacturing sector performance has been impressive in the last few decades.

However, the miracle of "Asia's new little dragons" (Schlossstein, 1991) ended when Thailand faced the economic crisis of 1997. According to the economic structure working group (TDRI, 1998), the causes for the economic turmoil are divided into two main groups: "immediate and root causes". As well known in general, the immediate causes included a large overseas debt burden carried by the private sector, over-investment in non-productive business, over-valuation of the baht, lack of transparency in some bank-and-business dealings and the subsequent loss of international confidence in the Thai economy as a whole. The root causes, which are as serious as the former, are a lack of competitiveness and sustainability. This is because Thailand no longer has a manufacturing base with very low cost labour and cheap raw materials as compared to other Asian countries such as the People's Republic of China (P.R.C.) and Vietnam.

During the economic boom, one key feature within the manufacturing sector was the successful combination of imported capital and technology with local labour and natural resources, and the export of resulting products through marketing ability of foreign 'partners'. But when Thailand lost the advantages of cost, its foreign 'partners' were quick to move away and invest in cheaper countries. Hence the country needs to urgently develop its own capabilities for self-reliance. Moreover, Yuthavong (1997) states that Thailand is at the stage of a "struggle for mobilisation and mastery" of which the key factors for

---

---

development of the country include market intelligence, technological forecasting and management, quality control and use of advance manufacturing technology.

Development of economic competitiveness is therefore one of the main objectives in the current Eighth National Economic and Social Development Plan (1997-2001) (NESDB, 1996). Thailand must prepare for changes in the world market, then among others it needs to enhance product standards and quality as well as quality management systems to respond to the development of free trade areas and the global market.

### **3.2 *Role of quality management in Thai manufacturing industry***

It has been accepted world-wide that one of the key factors for companies to be successful in the global market is quality. Most of the companies which are ahead their competitors and succeed in their businesses employ quality management practices. Bergman and Klefsjo (1994) suggest:

Quality has become an increasingly important means of competition on the world market. A strategy based on management commitment to continuous quality improvement has therefore to be applied more generally and systematically in any organization to enable it to keep its position on the market. Otherwise, large shares of the market will be lost to those competitors who are more aware of the importance of quality.

Quality management plays a very important role in Thai manufacturing industry for many reasons. Two key aspects are the export market and domestic demands, which will be addressed below.



### 3.2.1 The export market

As mentioned above, the manufacturing sector has been the biggest income earners in Thailand since 1985. However, the main reasons for the success of Thai manufactured exports has been the advantages of low-cost unskilled labour and an abundant supply of agricultural raw materials (Tambunlertchai, 1993, Lueprasitskul, 1997 and Sheehan, 1998). This competitive strength has gradually been eroded as countries like P.R.C., Vietnam, Indonesia and Burma begin to launch their manufactured products onto the world market. Moreover, free trade areas such as AFTA, NAFTA, APEC etc. will inevitably affect Thai exporters because of aggressive competition. Thailand needs a new strategy to compete with others in the global market. Sheehan (1998) suggests that Thailand should intensify its effort to become a "clever country" - to develop mechanisms to add value to its production and service industries. The author goes on to suggest that the ability of Thailand to become a "clever country" depends on its approach and personal development of its people. Strengthening Thai capability in science and technology and research and development (R&D) are vital so that it can have its own technology and capability to produce products to compete in the world market (TDRI, 1998 ). Apart from technology and skilled labour, Thai companies which aim to export must strengthen their knowledge and apply quality management practices in their organisations. According to Janchai *et al* (1997), manufacturing companies should increase their productivity, reduce costs, improve value-added, technology of production, use of local raw materials, introduce clean technology and go for ISO 9000 certification. Thai manufacturing companies need to compete in the aggressive competitive

---



---

environment not only by low cost production but also by improving their quality of products and services. They might first reach a competitive edge by catching customers at the low-end of the global market and later climb the ladder when they have developed the elements needed to 'raise their game' and develop competitive advantage using science and technology, human resources as well as management etc. Improving quality affects the company's success in many ways, for example a better market position, shorter lead times, reduced costs due to waste and rework, higher productivity (Deming, 1986 and Bergman and Klefsjo, 1994). The ISO 9000 series of quality systems standards is also important for Thai manufacturing exporters since it has been recognised world-wide. It has been seen as an essential prerequisite to the international trade (Ivancevich *et al*, 1994 and Kehoe, 1996). It is clear that if Thailand wants to be able to compete in the global market, among others, quality management will play a very important role in the Thai manufacturing industry.

### **3.2.2 Domestic demand**

Even though the export of manufacturing goods has grown rapidly in the past three decades, the main output of Thailand's industrial production still goes to the domestic market (Tambunlertchai, 1993). This market no longer belongs to producers, so called "production push". Now it belongs to customers who buy goods which are able to satisfy their needs, perhaps a situation closer to "marketing pull" (Nananukul *et al*, 1986a). Customers can now choose from a range of products according to perceived value, which means that they may be willing to pay more but they expect better quality and

---

service. Moreover, customer demands have become more sophisticated due to increased consumer awareness and market segregation of Thai society which is the result of the country's economic development. Markets are now educated to demand good quality, and consumers begin to appreciate quality in both imported and Thai goods. When examining a particular market, it is clear that company must develop quality management to survive in the internal market, not just for export. See Sasananan (1999), for a case study illuminating this issue in relation to the market for agricultural pumps. Low cost combined with effective quality management practices is important. In general, every country including Thailand should have the capability to produce quality products for the domestic market. A country that cannot compete in its own domestic market, cannot expect to be a fully successful exporter in the global market.

In summary, the role of quality management in Thai manufacturing industry was not clear in the past. However, it is now obvious that quality management will play a crucial role in Thai industry to help to improve its competitiveness in both domestic and external markets. To provide an overall perspective of quality management in Thailand, the next section describes the background and the application of quality management in Thailand.

### ***3.3 Background to and application of quality management in general***

The history of quality management in Thailand started a century ago in 1891, when a mineral laboratory was established to control the quality of raw

---



---

material and finished products for the Royal Mint (Arphasilp, 1980). Later this laboratory became the department of Science Services under the Ministry of Science, Technology and Environment. Its responsibility was to analyse raw materials against specification and its functions were later expanded to serve other industries as well as public. As the extent of manufacturing industry was limited in those times, most of this early control effort was led by government organisations and directed towards commercial commodities for export and import.

The management culture of Thailand's manufacturing industries has typically developed from the traditional Chinese style (family managed and owned) towards a more Western approach, but there has also been a significant movement toward the Japanese style in the last decade (Tabucanon, 1993). In the quality area, two Japanese companies in Thailand embarked on Quality Control Circle (QCC) activity as early as 1975 (Nananukul *et al*, 1986b). During the period 1986-1989, QCC were promoted and apparently prospered not only in manufacturing industry but also the service sector including banks, hospitals and government offices. After a period of strong promotion, QCC activity has since slowed down. At present, when Thai business people talk about QCC in Thailand they may well say that "QCC was born in America, was widely and successfully developed in Japan and then came to a dead end in Thailand" (Simachokdee, 1998a). However, this author also argues that there are a number of organisations, which do successfully use Japanese techniques for small group activities such as QCC, 5-S, Kaizen, etc., but they do not promote these outside the company.

---



---

Formal quality management systems are one of the approaches transferred to Thailand from the more industrially developed Western countries as well as Japan. Not until 1990 was the ISO 9000 series of quality systems standards adopted as Thai national standards, previously quality management in Thailand was usually managed informally, except in certain foreign owned and managed companies. The details of the adoption of ISO 9000 and its application in Thailand are described in the next section.

### **3.3.1 ISO 9000 series of quality systems standards**

After the publication of the ISO 9000 series of quality systems standards by the International Organisation for Standardisation (ISO) in 1987, the series was adopted and became the Thai national standards in 1990. The latter is known as ISO/TIS 9000. The Thai Industrial Standard Institute (TISI) at the Ministry of Industry which, in addition to its functions as a national standards body, also certifies companies in Thailand. In 1992, the first company to be certified was the lubricant plant of Shell (Thailand) Co. Ltd. located in Bangkok. By 1998 approximately 219 companies had been approved by TISI. In addition there are quite a number of overseas-based certification bodies operating in Thailand such as SGS, Lloyds, AJA, TUV, DNV, UL, etc. Seven hundred and twenty eight companies have already been certified by foreign certification bodies (Table 3-1). The majority of those companies manufacture their products for export to Asia, Europe or the United States of America (TPI, 1998).

The ISO 9000 series standards has now been widely accepted by Thai industry as part of an effective strategy for competitive advantage in the global market (Janchai *et al*, 1997). Despite of the fact that ISO 9000 has now become very important for Thai industry, it is still in an early stage of penetration of the large numbers of Thai SMEs (Krasachol *et al*, 1998). The number of companies in Thailand which have been certified to ISO 9000 is relatively low, compared with some other Asian countries (Krasachol *et al*, 1998 and TPI, 1998), and an ISO 9000 series certificate will often be advertised widely by its proud possessor. According to the report of NSTDA (1999), the number of certified companies was shown in Figure 3-1.

**Figure 3-1 ISO 9000 certified companies in Thailand by year of certification**

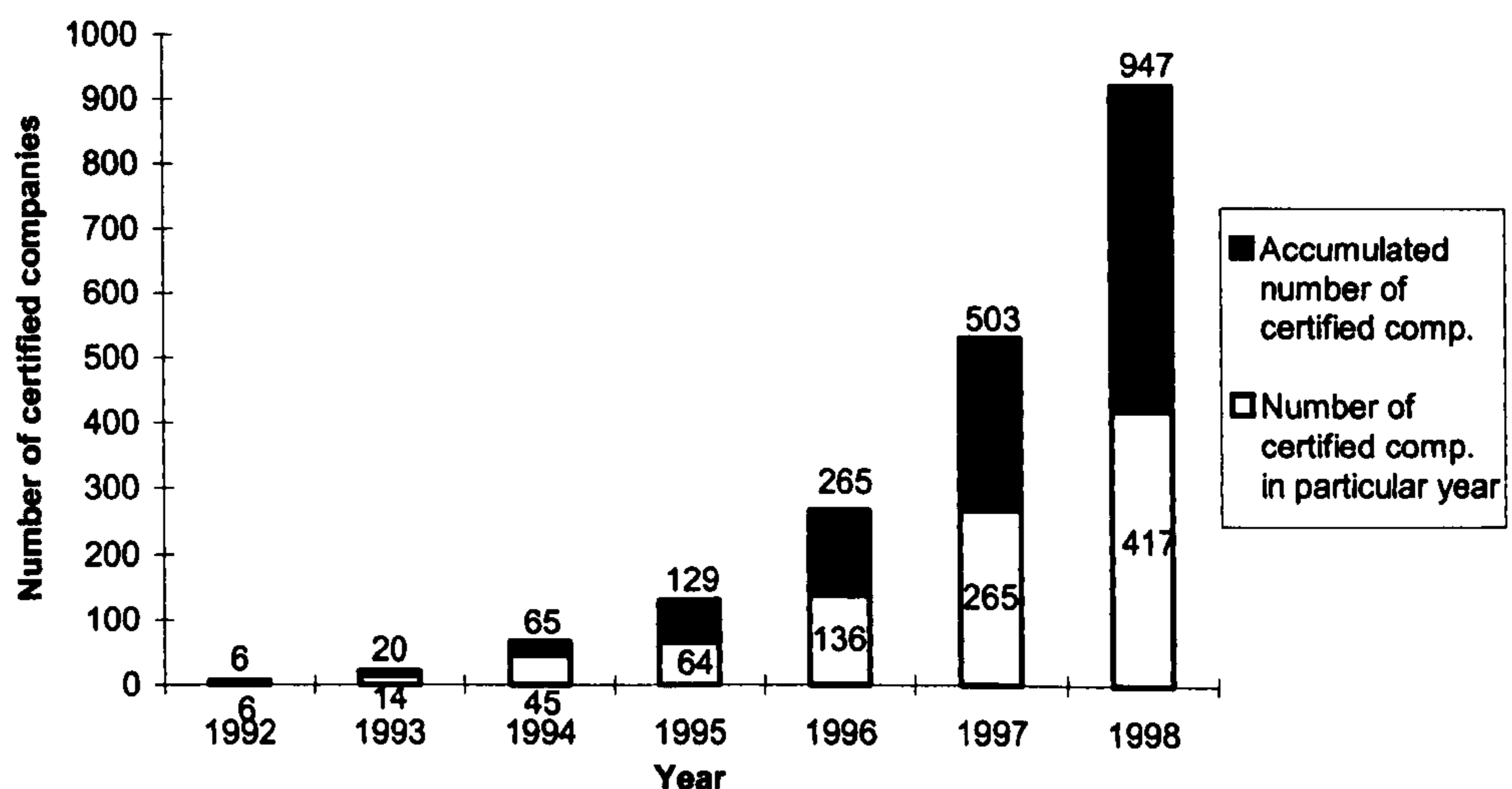

**Table 3-1 Number of certified companies by certifying body**

<b>Certifying body</b>	<b>Number of certified companies</b>
Bureau Veritas (Thailand) Ltd. (BVQI)	273
Thai Industrial Standard Institute (TISI)	219
SGS Yarsley SGS (Thailand) Ltd.	137
RWTUV (Thailand) Ltd.	114
Lloyd's Register	40
International Inspection Co., Ltd. (UL)	37
TUV Rheinland Thailand Ltd.	39
Det Norske Veritas Pte Ltd.	27
AJA EQS (Thailand) Ltd.	25
Intertek Testing Services (Thailand) Ltd.	12
British Standard Institute Quality Assurance (BSI)	6
TRADA Certification Ltd.	3
Japan Quality Assurance Organization	5
TUV Product Service	3
Quality Assurance Services PTY Ltd.	1
Reliability Centre for Electronic Components of Japan	1
BM Trada (Thailand) Ltd.	4
Bureau Veritas Quality International Ltd. (BVQI)	1
<b>TOTAL</b>	<b>947</b>

TISI plays a very important role on behalf of the Thai government to set up the national accreditation and certification system. As mentioned above, TISI have certified Thai companies against ISO 9000 since this standard was adopted to be the Thai national standard, however the ISO



---

institute was established in 1998 to take over the certification task from TISI. From May 1999, TISI no longer operates as a certification body, but as a national accreditation body for certification bodies.

As regards the plans for training of ISO 9000 consultants and assessors, The Federation of Thai Industry (FTI), co-operating with TISI, has organised many training courses for industry in order to help them implement and obtain ISO 9000 certification. The Thailand Productivity Institute (TPI) was established in 1996 to promote activities around productivity and quality management including ISO 9000 and TQM. This institute provides training and consultancy services to Thai industry. In addition, the Thai National Science and Technology Development Agency (NSTDA) gives technical and financial support for SMEs which have successfully implemented ISO 9000 and also establishes consultant training programme to develop the competence of Thai consultants.

### **3.3.2 Total quality management (TQM)**

TQM was introduced to Thailand as “Total Quality Control (TQC)” in the book of that name written by Nananukul *et al* (1986a). In their book, the authors refer to well known quality gurus such as Deming, Juran, Feigenbaum, Ishikawa, Crosby, etc. They describe the concepts of these gurus in Thai and use the term “Company Wide Quality Control (CWQC)” interchangeable with TQC. The PDCA concept is also mentioned in the book. Apart from these concepts which they provide by referring to the gurus and Western and Japanese experiences, the authors give examples of the TQC application based

---

on their own service-sector experience (banking). However, the authors seem to emphasise QCC activity rather than giving a clear account of the overall concepts of TQC. As mentioned above, QCC prospered during the 1986-1989 period, but more basic TQC concepts seem to have been neglected. Hence although TQM was introduced in Thailand several years ago, effectively it is still in its infancy (Krasachol *et al*, 1998). With the exception of a few large Thai-owned groups, TQM has been largely concentrated in foreign-owned companies. However, Thai industry is now more aware of the importance of TQM, and a number of books have been published on relevant management issues, TQM, quality tools and techniques. Most of these are translations of well-known books from either Japan or the USA and include 'In Search of Excellence' (Peters and Waterman, 1982), 'Suggestion System' (Toyosawa, 1988), 'Company-wide Quality Control' (Kondo, 1995) and '5S Techniques' (Hiroyuki *et al*, 1992) etc. Some are written by Thai authors, for example 'TQM living handbook: an executive summary' (Lueprasitskul, 1997) and 'TQM: Handbook for organisation 2000' (Simachokdee, 1998b). Those books are text or resource books that provide knowledge on management of quality to Thai academics, students in quality management, and practitioners in industry who wants to obtain knowledge and apply it in their jobs. But research literature and case studies on the application of TQM in Thai organisations is very sparse compared with that relating to developed countries like UK and USA.

Hence the introduction of quality concepts from more developed countries is essential. In this regard, Prasad *et al* (1996) have carried out an



illuminating comparative benchmarking study of US companies and their Mexican subsidiary plants. These authors make it clear that some US companies have consciously employed a dual strategy of moving manufacturing facilities to developing countries where labour costs are lower, and then applying advanced quality management practices to these plants, in order to avoid the quality problems suffered by the indigenous manufacturing industry. According to the benchmarking results described in this article, which was based on the Malcolm Baldrige award criteria, this strategy has been successful in achieving competitive quality performance.

A similar process has also operated in Thailand, and TQM has been transferred to Thailand from Western developed countries as well as Japan since the 1970s through joint partnerships or foreign-owned companies as will be seen in the case studies in chapter 7.

### **3.3.3 Quality awards**

At present, Thailand does not have a national quality award. However, a QC Project was set up in 1982 by Technology Promotion Association (Thailand-Japan) (TPA) to educate people on QC idea and method. TPA is a private organisation established by support from Japan in 1973 to transfer knowledge and new technology, particularly from Japan, to Thailand. In the QC project, one of the main activities is a "QC Prize" which is arranged every year to promote and support the QC activities of various organisations and provide recognition to those who made significant achievements.

---



Furthermore, NSTDA co-operated with TPI to form a project for setting up a National Quality Award (NQA) for Thailand in 1996. A working committee was appointed to carry out the tasks required to establish the criteria of the NQA, the process of assessment to be used and to propose guidelines to establish a formal NQA in Thailand. The working committee met many times to brainstorm and to study the quality awards of other countries such as the US Malcolm Baldrige National Quality Award (MBNQA), the European Quality Award, the Singapore National Quality Award as well as the Deming Prize (Japan). After the criteria (which were based largely on the MBNQA) had been set up, a seminar was organised to test the criteria by working with participants from Thai industry. The working committee finished their work in 1997. Unfortunately, Thailand then had to confront the economic crisis so both NSTDA and TPI could not obtain further funding to proceed with the project. However, both institutes are waiting for the appropriate time to launch the NQA for Thailand.

### **3.4 Summary**

Before the economic crisis which developed in 1997, Thailand was one of the 'small Asian Tiger' countries which had a rapid economic growth rate. It had successfully developed a substantial manufacturing industry. During this fortunate period, the successful Thai economy depended very much on its manufacturing sector, and Thailand's largest income was from export of manufactured products. More recently, the Thai economy has stagnated because of both short-term and more fundamental reasons. The immediate causes include a large overseas debt burden carried by the private sector, over-investment in non-productive business, over-valuation of the baht, lack of transparency in some bank-and-business dealings and the subsequent loss of international confidence in the Thai economy as a whole. The root causes are the lack of competitiveness and sustainability, as described above.

Management of quality will in the future play a very important role in Thai manufacturing industry because of both export and domestic market demands. Due to external pressures, Thai companies increasingly need to introduce quality management practices. As the global market constantly becomes more competitive, while customers in the domestic markets make increasingly sophisticated demands, quality management appears as a vital tools to help Thai manufacturing industry remain competitive in these turbulent circumstances. The ISO 9000 quality systems standards, TQM and the NQA for Thailand will be major themes for Thai industry as it embarks on its journey of quality improvement.

---

Like many other developing countries, Thailand started by exporting manufactured products which competed on price in the world market due to low cost labour. Inward investment and various joint venture companies took advantage of this position. It has now been realised that there is a need to move forward and embrace more advanced technology and management. It can be seen, from the discussion in Chapter 2 and from this chapter, that Thailand has exhibited similar trends and problems to other developing countries, but it also appears that each country is at a different stage in this process. Among ASEAN countries (which are Singapore, Malaysia, Indonesia, the Philippines, Brunei, Vietnam, Cambodia, Myanmar, Laos and Thailand), it might be concluded that Thailand is in the middle of the spectrum of development. Singapore and Malaysia are at the front while all the others are behind.



## **4. The progress of quality management in Thailand**

### **4.1 Introduction**

This chapter describes the progress of quality management, especially as regards ISO 9000 certification and TQM implementation, in Thailand. As mentioned in Chapter 3, Quality management is new to Thai industry, but it has been adopted with great speed in recent years. In order to identify the current position, trends and attitudes within Thai industry, an exploratory study was conducted using a survey method in August and September 1996. The result of this study provides background information about quality management in Thailand which is useful for the further studies that are described in the next three chapters (6, 7 and 8). This chapter begins with a description of the questionnaire and survey method. Then the results from descriptive statistical analysis are provided to describe issues in ISO 9000 implementation and effect of ISO 9000 implementation. TQM issues are described next in the section on TQM implementation, quality management tools and TQM progress. The chapter ends with final conclusions drawn from the survey results.

---

## **4.2 Questionnaire and survey**

A questionnaire was designed and developed from the literature review on quality issues, especially ISO 9000 and TQM. It was divided into three sections: company profile, ISO 9000 details and TQM details.

The first section provided general information concerning ownership, number of employees, capital investment, main area of manufacturing, percentage of export and level of turnover. The data in this section are used to classify the companies into different types. The ISO 9000 details section provided information on the current status of ISO 9000 in Thailand. It referred to reasons for pursuing the standards, the scope, the duration, the obstacles and benefits of ISO 9000. The TQM details section identifies the knowledge about and the implementation including benefits of TQM in Thailand as well as quality tools that are applied. The researcher contacted two companies and three academics in Thailand to review and comment on the clarification of all questions. Then the questionnaire was improved and revised.

For the survey, one thousand and two hundred modified and improved questionnaires (appendix 1) were distributed to Thai companies using the directory of the Industrial Estate Authority of Thailand (1995/1996), the Profiles of Board of Investment - Promoted Companies and Sectors (1995) and The Federation of Thai Industries Directory (1995-1995). The companies covered all types of industry and included 207 companies certified to one of the ISO 9000 series (at that time). A total of 217 companies replied to the

questionnaires which made a response rate of 18 per cent. Eighty-six per cent (187) of the responses were from companies interested in ISO 9000 implementation. Forty-one per cent (88) of the responses were from companies which were certified. According to NSTDA (1996) which reported that 207 Thai companies were certified to ISO 9000, the survey therefore covered 43 per cent of ISO 9000 registered firms.

As shown in Figure 4-1, the largest proportion of the respondents was medium and larger companies. A total of 157 companies (72 per cent) had turnovers more than one million baht. Electrical and electronic manufacturing companies were the largest group which responded to the questionnaire as illustrated in Table 4-1. All of electrical and electronic manufacturing companies were either certified or were in the process of ISO 9000 implementation.



Table 4-1 Number of companies interested in ISO 9000 implementation by industrial sector

Figure 4-1 Profile of respondents

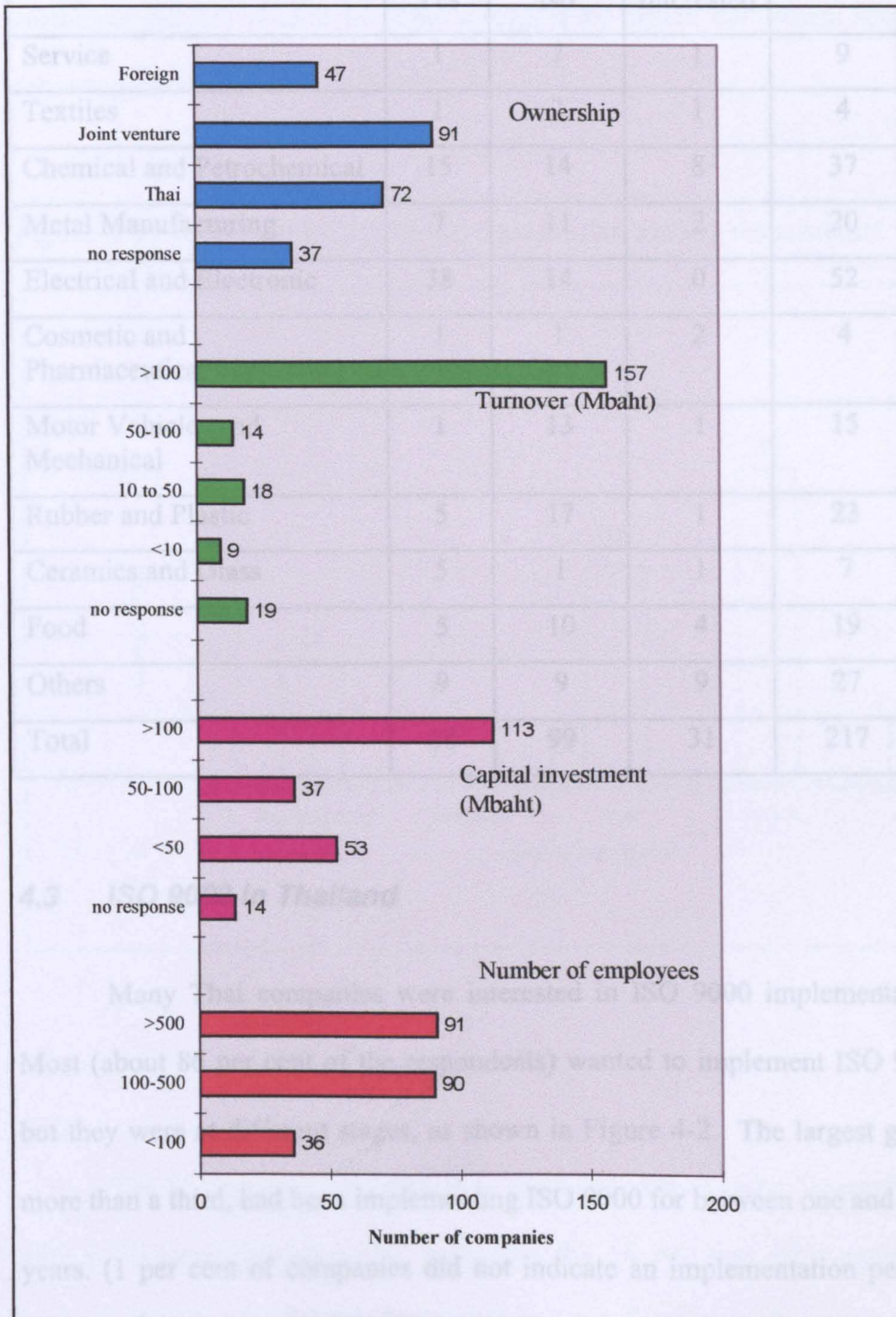



**Table 4-1 Number of companies interested in ISO 9000 implementation by industrial sector**

Industrial sector	Certified?		Not Interested	Total
	Yes	No		
Service	1	7	1	9
Textiles	1	2	1	4
Chemical and Petrochemical	15	14	8	37
Metal Manufacturing	7	11	2	20
Electrical and Electronic	38	14	0	52
Cosmetic and Pharmaceutical	1	1	2	4
Motor Vehicles and Mechanical	1	13	1	15
Rubber and Plastic	5	17	1	23
Ceramics and Glass	5	1	1	7
Food	5	10	4	19
Others	9	9	9	27
Total	88	99	31	217

### **4.3 ISO 9000 in Thailand**

Many Thai companies were interested in ISO 9000 implementation. Most (about 86 per cent of the respondents) wanted to implement ISO 9000, but they were at different stages, as shown in Figure 4-2. The largest group, more than a third, had been implementing ISO 9000 for between one and three years. (1 per cent of companies did not indicate an implementation period.) Nearly 14 per cent were not interested in ISO 9000 for various reasons, such as a commitment to a different type of quality system (e.g. GMP (Good

Manufacturing Practice) which is particularly appropriate for food, cosmetics and pharmaceutical industries). The other reasons were that they were not yet ready, not in a position to implement ISO 9000 at present or that their customers did not require it. The average time which companies spent in achieving certification was 1.5 years.

**Figure 4-2 Progress of ISO 9000 implementation among respondents**

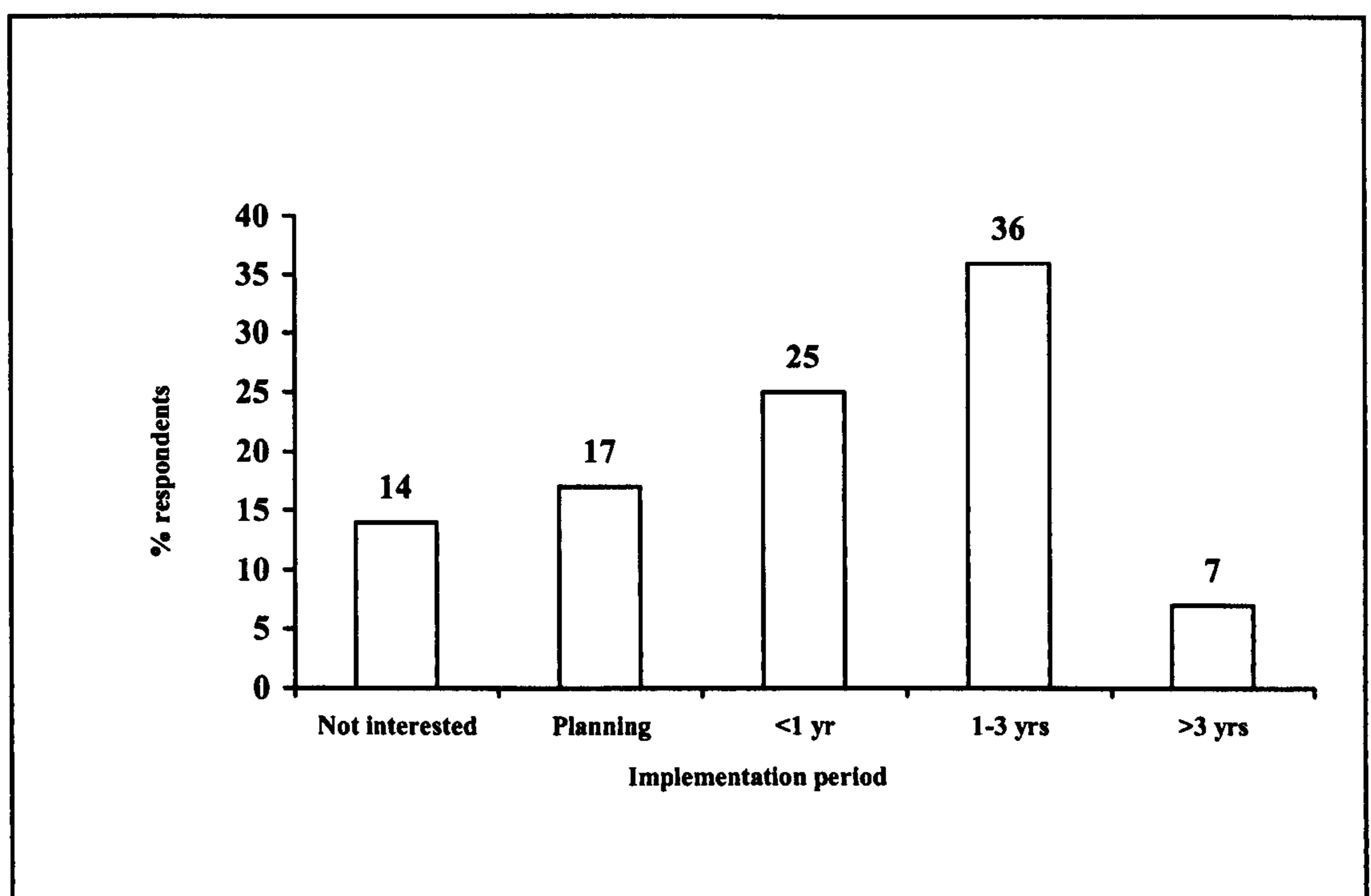

The 85 per cent of companies in Figure 4-2 which were “interested” in ISO 9000 implementation (i.e. excluding the 14 per cent who were “not interested”) are now analysed further. Figure 4-3 shows that 60 per cent of the interested respondents were joint venture or foreign owned companies and only 36 per cent were Thai companies. (Four per cent of companies did not



---

indicate ownership.) However, the largest proportions of interested companies (24 per cent) were Thai companies. The potential clearly exists for the proportion of ISO 9000 certified companies which are Thai-owned to increase, and this trend is to be anticipated in the next few years.

As in the UK and Europe, ISO 9002 has been implemented in preference to ISO 9001 and ISO 9003. Most of the respondents have been implementing ISO 9002. Only 10 per cent and 0.5 per cent were interested in ISO 9001 and ISO 9003 respectively. For joint venture and foreign companies, the design function (covered by ISO 9001) is often done abroad by the foreign parent organisations.

The electrical and electronics sector was the most interested in one of the ISO 9000 series standards. Table 4-1 shows that the largest number of certified companies belonged to that sector. Certification to one of the ISO 9000 series had mostly been achieved by large companies with more than 500 employees, as shown in Figure 4-4.



4.4 The importance and effect of ISO 9000 Implementation

Figure 4-3 Ownership of the respondents interested in ISO 9000

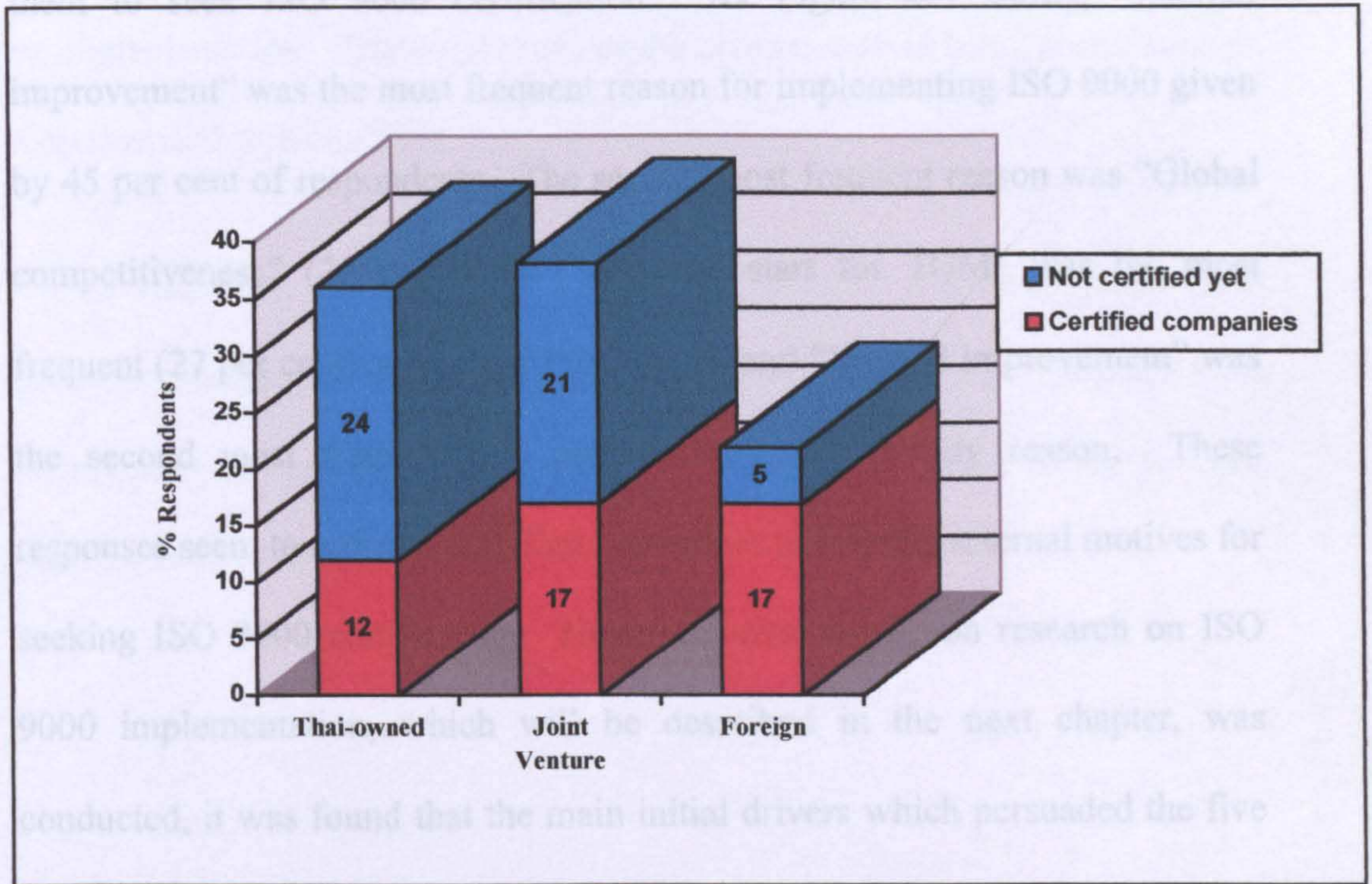
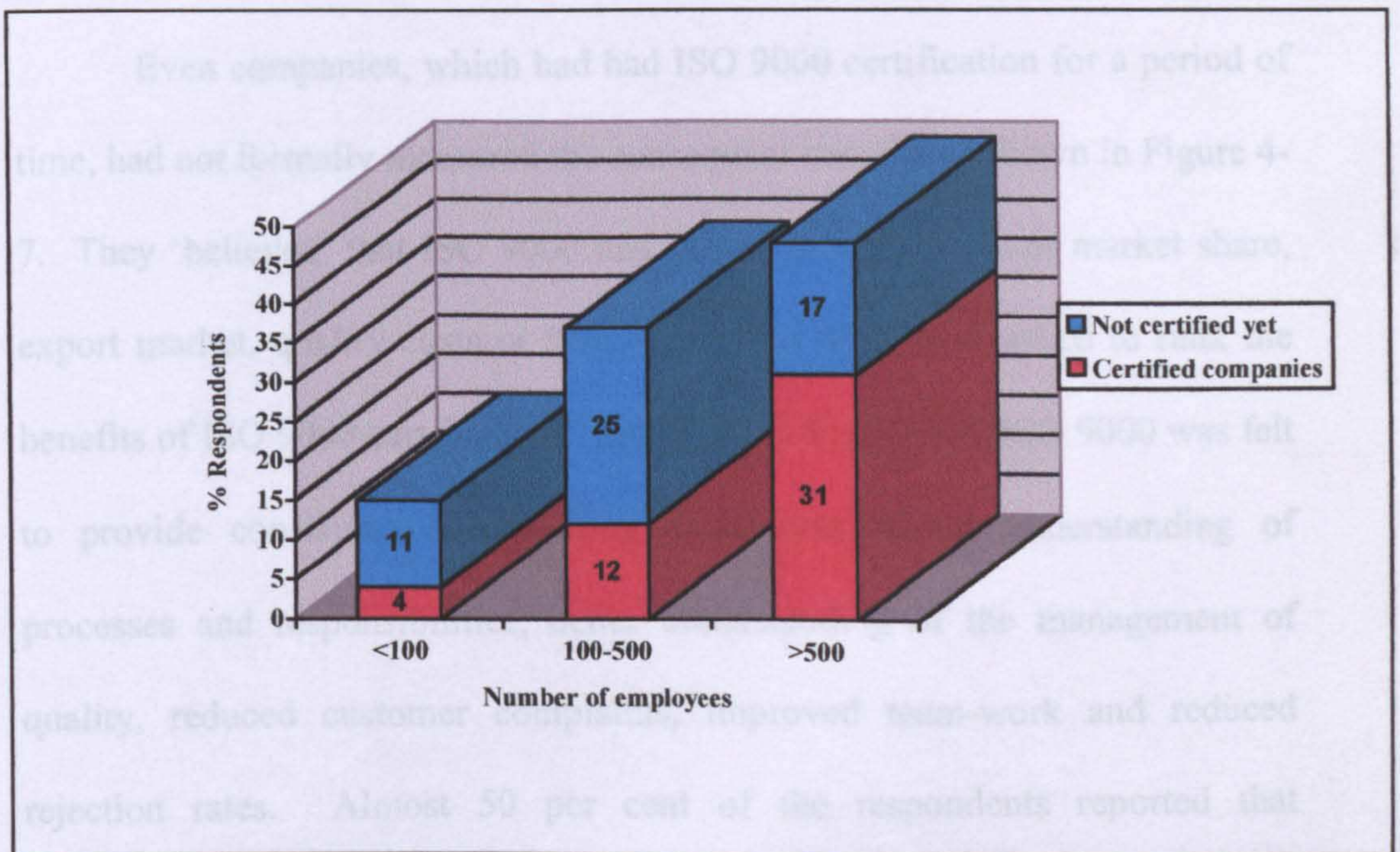

Figure 4-4 Size of the respondents interested in ISO 9000 implementation





---

#### **4.4 The importance and effect of ISO 9000 implementation**

The respondents were asked to prioritise reasons which encouraged them to seek ISO 9000 certification. As Figure 4-5 shows, "Internal improvement" was the most frequent reason for implementing ISO 9000 given by 45 per cent of respondents. The second most frequent reason was "Global competitiveness" (26 per cent). "A good start for TQM" was the most frequent (27 per cent) second priority reason, and "Internal improvement" was the second most frequent (22 per cent) second priority reason. These responses seem to indicate that Thai companies had strong internal motives for seeking ISO 9000 certification. However, after the action research on ISO 9000 implementation, which will be described in the next chapter, was conducted, it was found that the main initial drivers which persuaded the five case-study companies to go for ISO 9000 series standard, appeared to be from external influences.

Even companies, which had had ISO 9000 certification for a period of time, had not formally measured the consequent benefits as shown in Figure 4-7. They 'believed' that ISO 9000 had helped to improve their market share, export market, quality costs or turnover. They were also asked to rank the benefits of ISO 9000 certification. As shown in Figure 4-6, ISO 9000 was felt to provide consistency in working procedures, better understanding of processes and responsibilities, better understanding of the management of quality, reduced customer complaints, improved team-work and reduced rejection rates. Almost 50 per cent of the respondents reported that "Consistency in working procedures" was a very important benefit which they

---



had gained from ISO 9000 certification. The approach which most of them (59 per cent of the respondents) used was a “Top-down approach”. Sixty-two per cent reported that their management had been fully involved in the process of implementation. Fifteen per cent of the companies had hired consultants to help them achieve certification.

The most difficult task for companies was preparing quality and procedure manuals and implementing “Documentation control” (clause 4.5). “Corrective and preventive action” (clause 4.14) was also reported to have been difficult to document and implement.



Figure 4-7 Benefit measurement of ISO 9000

Figure 4-5 Reasons for ISO 9000 certification

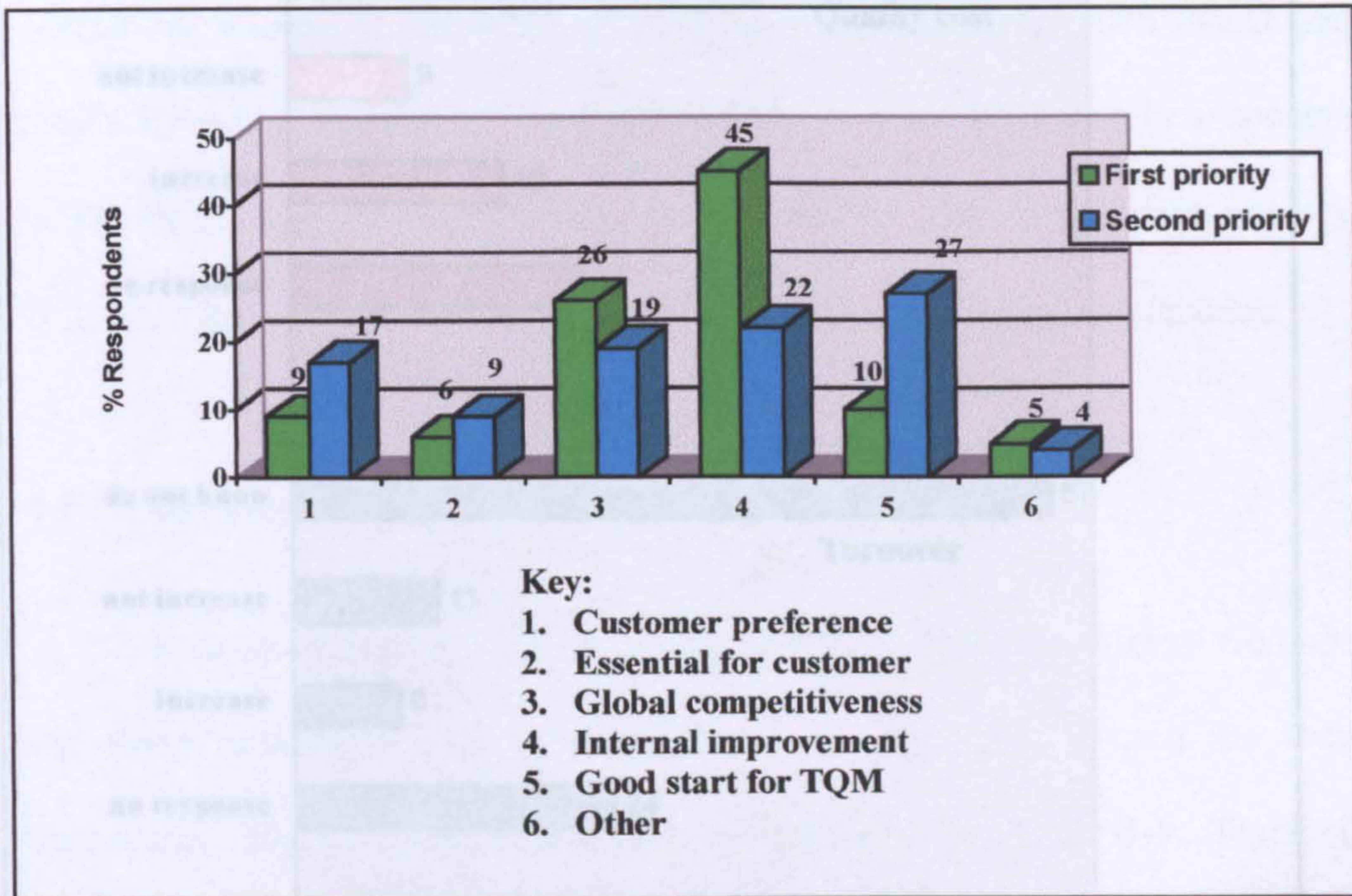
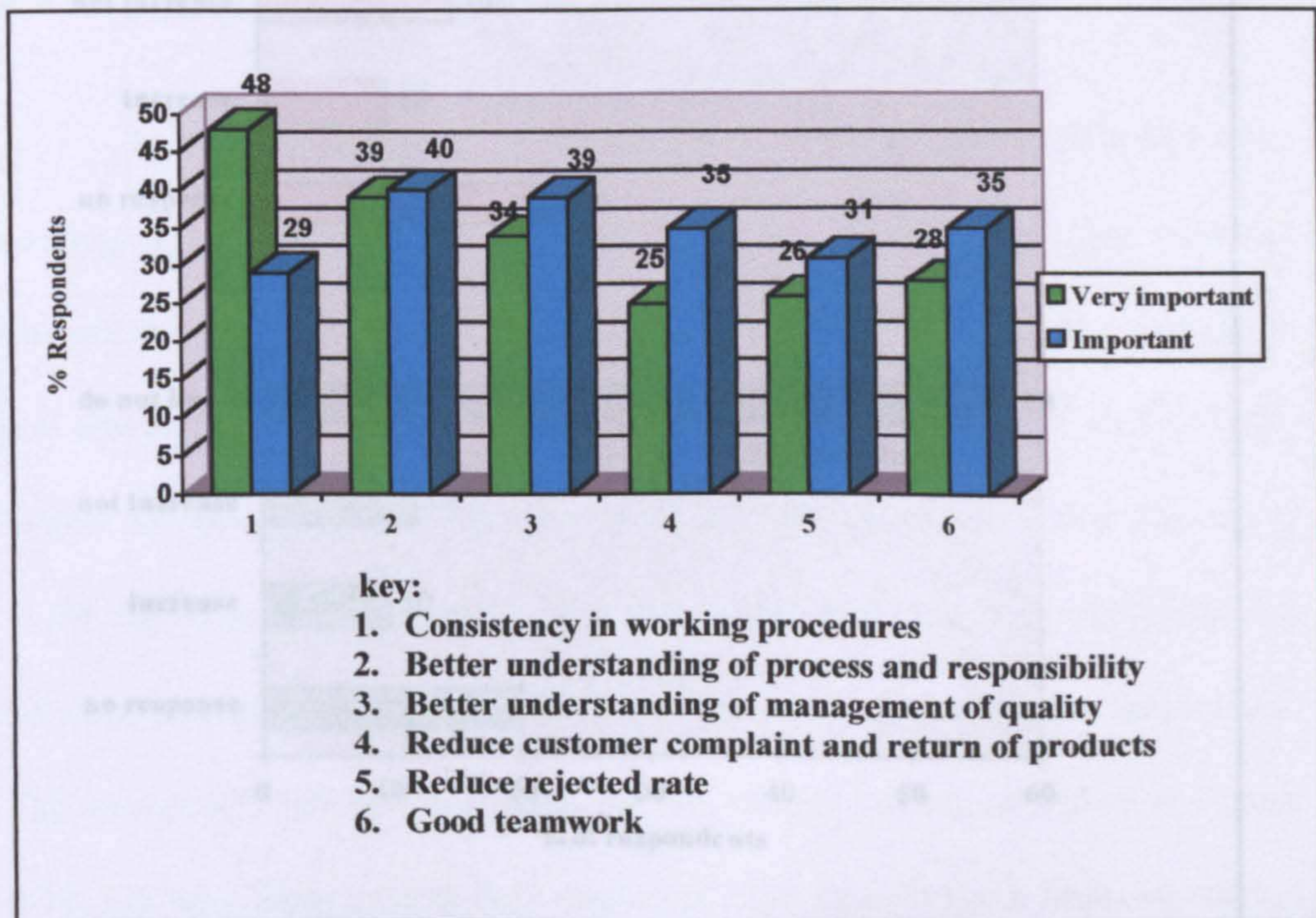
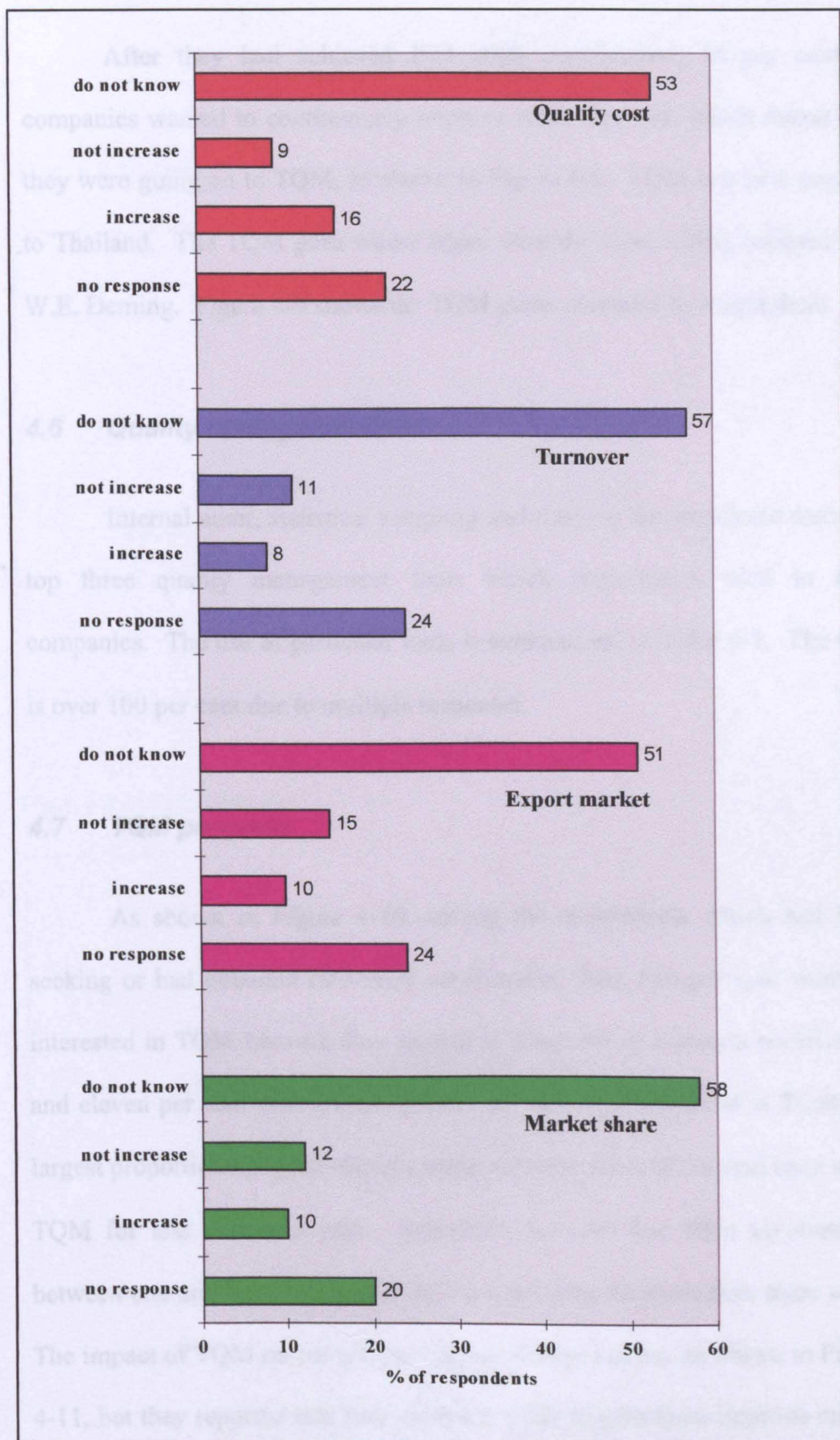

Figure 4-6 Relative benefits of ISO 9000





**Figure 4-7 Benefit measurement of ISO 9000**





---

#### **4.5 Total quality management implementation**

After they had achieved ISO 9000 certification, 58 per cent of companies wanted to continuously improve what they did, which meant that they were going on to TQM, as shown in Figure 4-8. TQM is a new concept to Thailand. The TQM guru whose ideas were the most widely adopted was W.E. Deming. Figure 4-9 shows the TQM gurus favoured by respondents

#### **4.6 Quality management tools**

Internal audit, statistical sampling and training the workforce were the top three quality management tools which respondents used in their companies. The use of particular tools is summarised in Table 4-1. The total is over 100 per cent due to multiple responses.

#### **4.7 TQM progress**

As shown in Figure 4-10, among the respondents which had been seeking or had obtained ISO 9000 certification, forty two per cent were not interested in TQM because they wanted to fine-tune or maintain certification and eleven per cent were planning to do so. Of those involved in TQM, the largest proportion (24 per cent) of companies were those which had been using TQM for less than one year. Seventeen per cent had been involved for between one and three years, and only six per cent for more than three years. The impact of TQM on companies was not clearly known, as shown in Figure 4-11, but they reported that they expected TQM to help them improve market share, export market, quality costs and turnover.

---



Table 4-2 Quality management tools

Quality management tool	per cent
Statistical sampling	63
Statistical process control	54
Team building	39
Problem solving techniques	47
Taguchi techniques	43
Internal audits	8
Quality costing	13
QFD	23
Leadership	12
System integration	10
Remove barriers	16
Empowering workforce	29
Training workforce	62
Benchmarking	28

Figure 4-8 Activities after certification

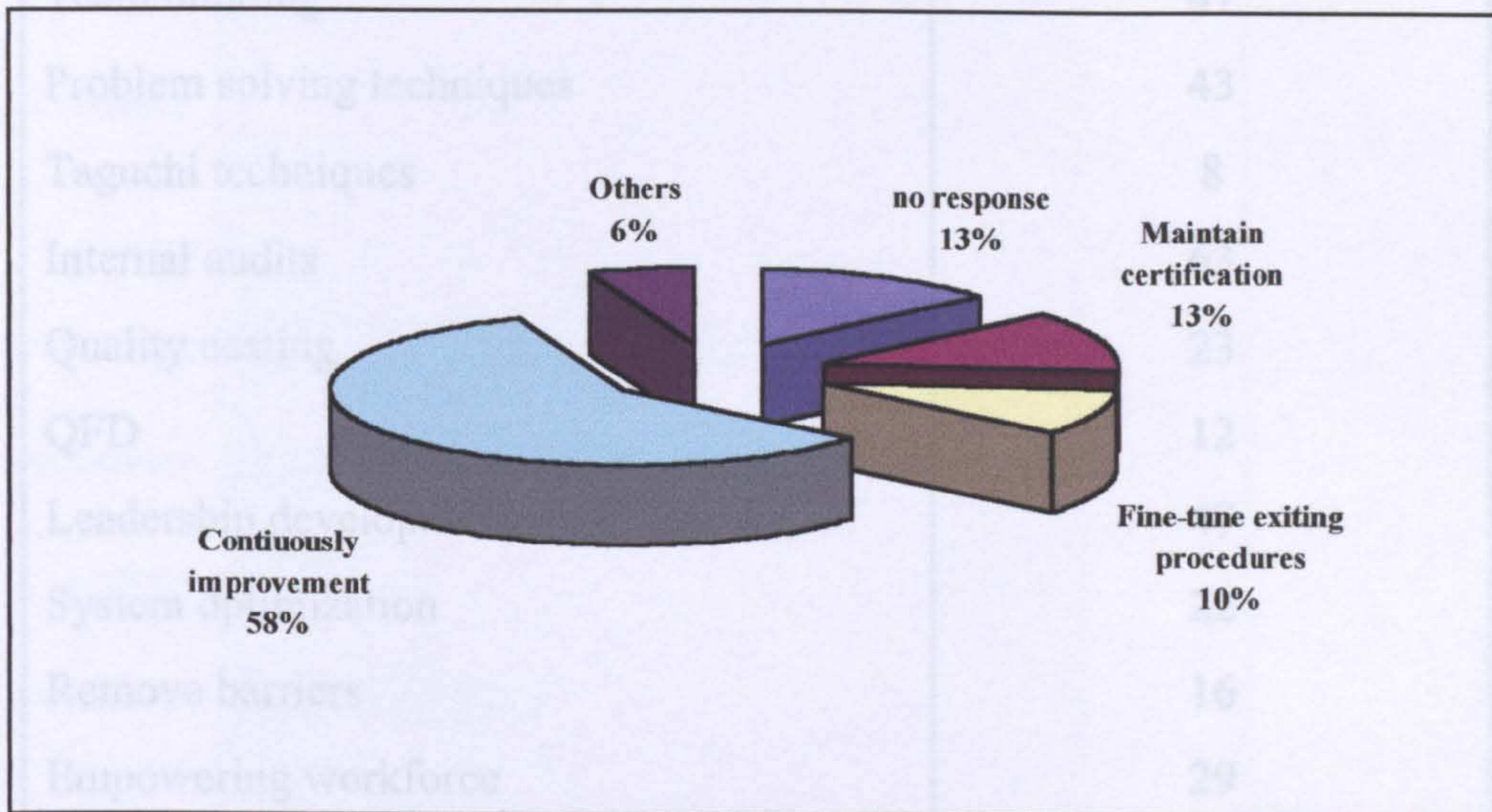
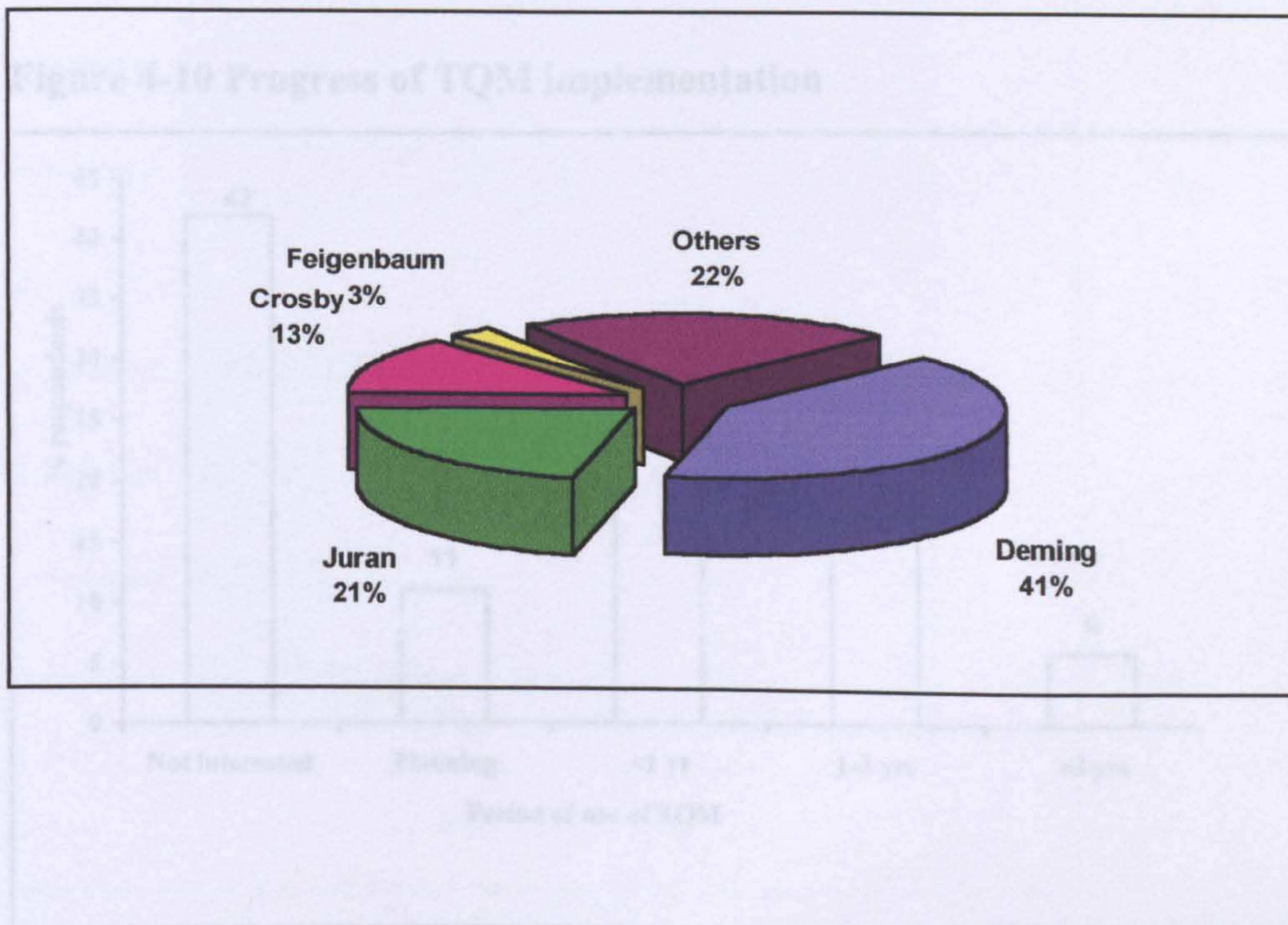

Figure 4-9 TQM gurus





**Table 4-2 Quality management tools**

Quality management tool	per cent
Statistical sampling	63
Statistical process control	54
Quality circles	39
Team building	47
Problem solving techniques	43
Taguchi techniques	8
Internal audits	63
Quality costing	23
QFD	12
Leadership development	47
System optimization	22
Remove barriers	16
Empowering workforce	29
Training workforce	62
Benchmarking	28

**Figure 4-10 Progress of TQM implementation**

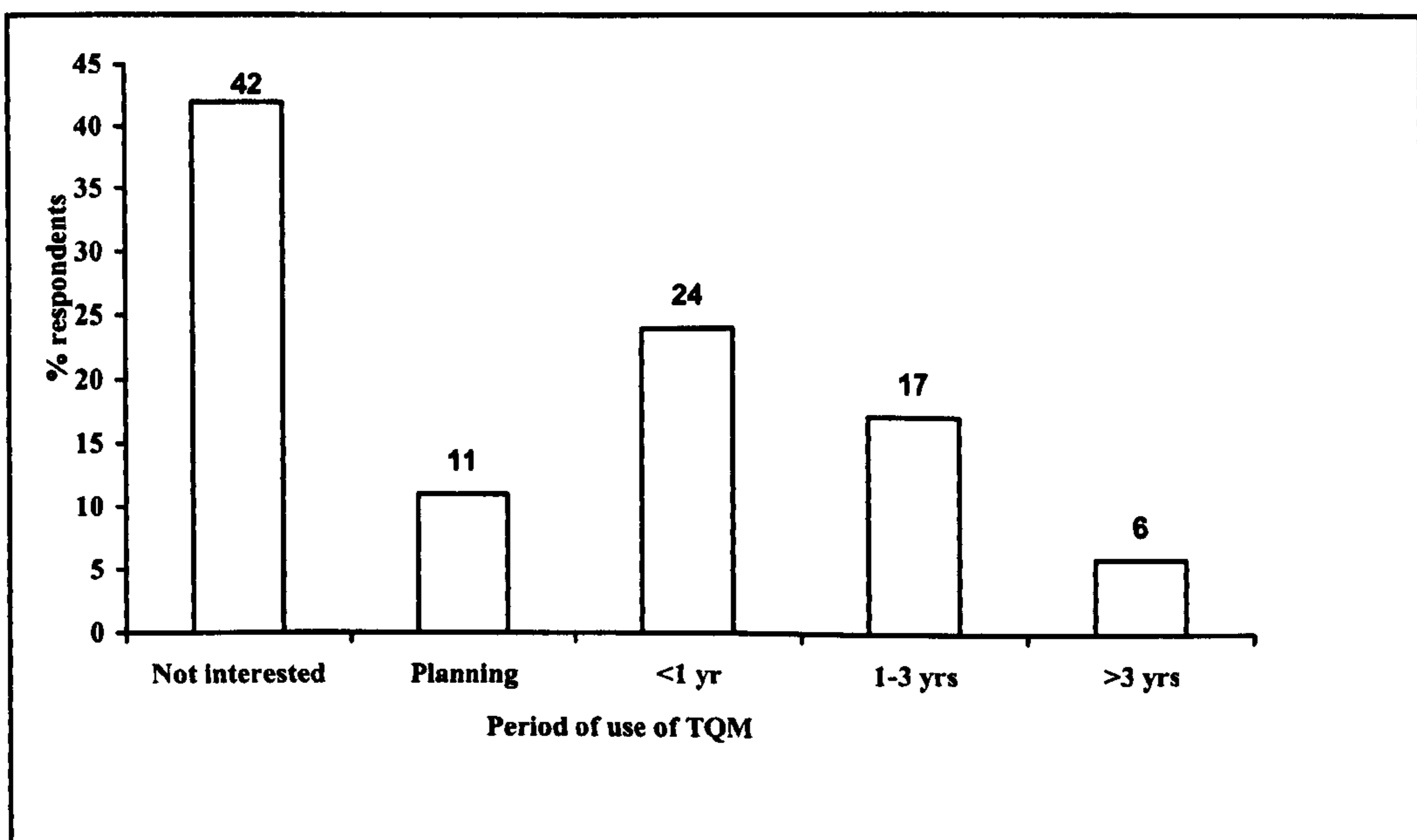
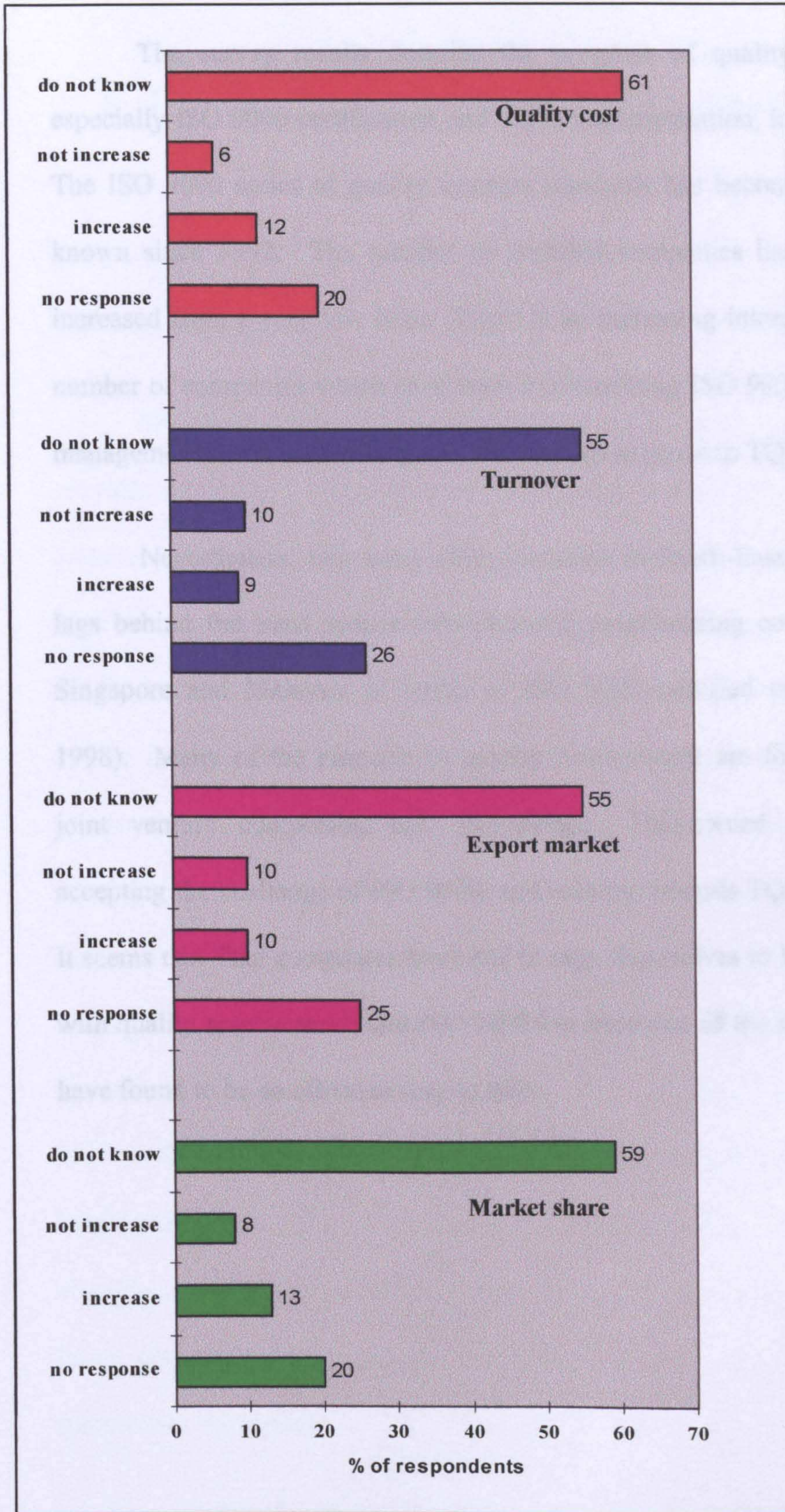



Figure 4-11 Benefit measurement of TQM





---

## **4.8 Summary and conclusions**

The survey results describe the progress of quality management, especially ISO 9000 certification and TQM implementation, in Thai industry. The ISO 9000 series of quality systems standards has become more widely known since 1992. The number of certified companies has tremendously increased from a very low base. There is an increasing interest in TQM. A number of companies which have been implementing ISO 9000 based quality management systems are using it as a basic step to go on to TQM.

Nevertheless, like many other countries in South-East Asia, Thailand lags behind the most industrially-advanced neighbouring countries such as Singapore and Malaysia in terms of ISO 9000 certified companies (TPI, 1998). Many of the pioneers in quality management are foreign-owned or joint venture companies, but, increasingly, Thai-owned companies are accepting the challenge of ISO 9000, and looking towards TQM in the future. It seems that Thai companies have had to urge themselves to become familiar with quality management, and ISO 9000 has been one of the tools which they have found to be an effective way to start.

## **5. The implementation of ISO 9000 in Thai industry**

### **5.1 Introduction**

The results from the survey study described in the previous chapter provided information on the progress in Thailand of ISO 9000 series of quality systems standards as well as TQM. After gaining initial information and ideas from the survey, the author conducted further action research to obtain more insight into the issues of ISO 9000 implementation in general, and the Thai context in particular. This chapter describes the implementation of ISO 9000 standards in the Thai manufacturing companies which were studied. The details of the research process as well as the method of analysis are explained, followed by a general description of implementation procedures in the investigated companies and also background information on the companies themselves. The main findings of this investigation, which are the issues of ISO 9000 implementation in the Thai context, concern the companies' motivation for pursuing ISO 9000; the implementation process; factors and obstacles; the impact of the implementation process on organisation; and future plans. These are explained sequentially and a final conclusion then summarises the chapter.



---

## **5.2 Research process and analysis procedures**

When the Thai National Science and Technology Development Agency (NSTDA) launched the “ISO 9000 Consulting Support Project for Thai Industry” in 1997, the researcher carried out a parallel programme of action research to examine the process of implementation, and identify generic issues for Thai industry. The objectives of the NSTDA project were to encourage Thai industry to be more competitive by conforming to International standards and to study the process of ISO 9000 implementation including its impact on Thai companies. Five Thai companies were selected from the fifteen companies which applied to participate in this project. The criteria of selection were:

1. at least 51% Thai owned;
2. commitment of top management to the project; and
3. small-medium enterprises (SMEs) had selection priority.

The project started in April 1997. NSTDA provided consultants to help the companies in ISO 9000 implementation. The researcher acted as one of the consultants who assisted them through the implementation process. The project was expected to last 15 months.

A consulting plan (Appendix 2) was drawn up and distributed to all participating companies. Consultants made appointments with each company, visited them from time-to-time to set up and progress implementation of the quality system according to the appropriate ISO 9000 series standard. The

---

consulting team also conducted various training courses concerning the requirements of the ISO 9000 series standard and implementation process, such as an introduction and interpretation of ISO 9000; a documentation course; an internal quality audit course, etc.

During the consulting process, the data were collected from several sources. Structured interviews (appendix 3) was carried out with the project co-ordinator, who was normally the quality management representative (QMR), and top management if they were available at the first visit to every companies. While the implementation process was going on and the consulting teams visited the companies, participant observation, company documents, and the reports made by consulting team were used as data collection methods through out the project. At the end of the project when the participating companies had quality systems in place, in-depth interviews were conducted to acquire additional data.

The grounded theory method is considered suitable for research which intends to build theory (Easterby-Smith, 1991, Yin, 1994, Gill and Johnson, 1997). This approach seemed appropriate for the data analysis since the objective of this research was to generate explanations of the generic issues of ISO 9000 implementation for the companies pursuing it. Therefore the data collected was analysed through the process of coding, categorising and identifying relationship among the categories (Jones, 1985 and Strauss and Corbin, 1990). Strauss and Corbin (1990) also suggest that an analytic procedure can be achieved by questioning and making comparisons. Hence, the process of analysis was conducted using these main procedures.

---



A three-step procedure (Strauss and Corbin, 1990) was employed to analyse the data. The steps were open coding; axial coding; and selective coding. It should be noted that although they are separate levels or stages of coding, the processes are in practice carried out simultaneously, especially at the stages of open coding and axial coding.

### ***Open coding***

This starts with breaking the data into categories. The researcher tries to find concepts in the data by asking questions such as 'what is the major idea brought out in this sentence or paragraph?'. The process of open coding is as follows:

1. Conceptualising data;
2. Discovering categories; and
3. Developing categories in terms of their properties and dimensions

Cognitive mapping (Jones, 1985) was used to identify concepts and tentative relationships between them. Examples of cognitive maps including categories as well as their properties and dimensions which were identified from the data were shown in Appendix 4.

### ***Axial coding***

After the categories and their properties and dimensions were discovered, axial coding is the process of making connection between a

---

category and its sub-categories by using a 'paradigm model' which can be described as Figure 5-1.

**Figure 5-1 Paradigm model (after Strauss and Corbin, 1990)**

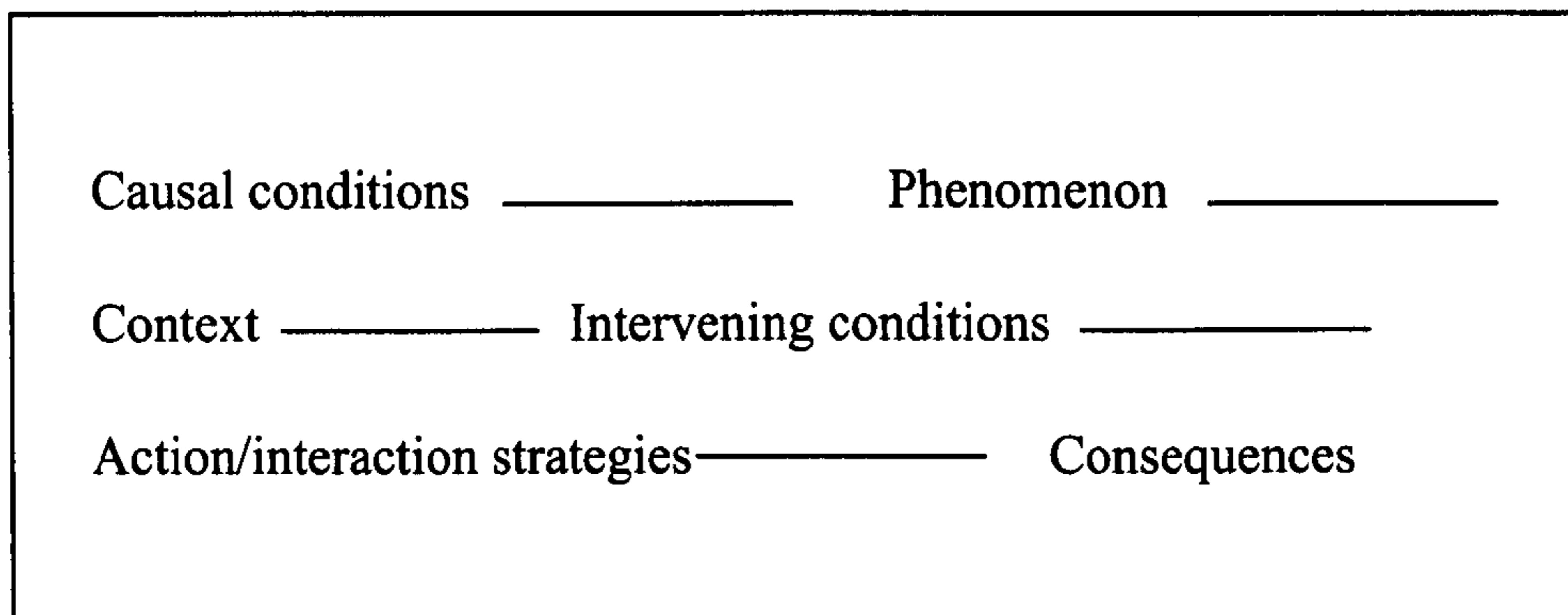

In this process, the following techniques were used iteratively to identify the relationships among categories.

1. The hypothetical relating of subcategories to a category;
2. The verification of those hypothesis against actual data;
3. The continued search for the properties of categories and subcategories and the dimensional locations of data;
4. The beginning of exploration of variation in phenomena.

### ***Selective coding***

This procedure covers integration of the categories to form a grounded theory, and identifies key relationships between major categories. There are several steps through which this is done, as follows:



1. Explicating the story line and identify the core category;
2. Relating subsidiary categories to the core category using the paradigm model (Figure 5-1);
3. Relating categories at the dimensional level;
4. Validating those relationship against data;
5. Filling in categories which need refinement/development.

A 'temporary hypothesis' was created and tested according to the data throughout the analysis process. Both inductive and deductive thinking help to ensure that the theory is grounded (Strauss and Corbin, 1990). These authors suggest that deductive statements of relationships, suggested possible properties and their dimensions should be proposed in the coding process and then verified against data. While using the comparative method, superordinate concepts were created from bringing together similar categories. Furthermore, the process of comparison led to ideas about the dimensions and properties of the category, including its relationship with other categories and including the differences as well as the similarities between informants' constructions (Jones, 1985). By following the procedures mentioned above iteratively, the implementation process was identified as a core category (Figure 5-2). Hence, the explanation of the ISO 9000 implementation process was then described.

### **5.3 Background of five case companies and the general implementation process guided by consulting team**

The companies which were selected to participate in the project were from manufacturing industry. For confidentiality, these companies are identified as company I, II, III, IV and V. Table 5-1 gives outline details of them. Background information for each company is provided in the following sections.

**Table 5-1 The collaborating companies.**

<b>Company</b>	<b>Industry type</b>	<b>% export production</b>	<b>Number of Employees</b>	<b>Capital Investment (MB)</b>	<b>Ownership</b>
I	Finished frozen food	0	506	40	Thai
II	Pharmaceutical products	0	80	20	Thai
III	Air conditioner	20	207	30	Joint venture (with 23% Singapore)
IV	Heat exchanger	2	250	50	Thai
V	Lighting fixture and trunk for cable support	20	100	15	Thai

The general implementation process guided by consulting team in section 5.3.1 is described before the cases (5.3.2-5.3.6) in order to provide an idea of the general approach that the consulting team used to work with companies. The specific characteristics found during the implementation process for particular companies are explained afterwards.



Figure 5-2 Framework of ISO 9000 implementation

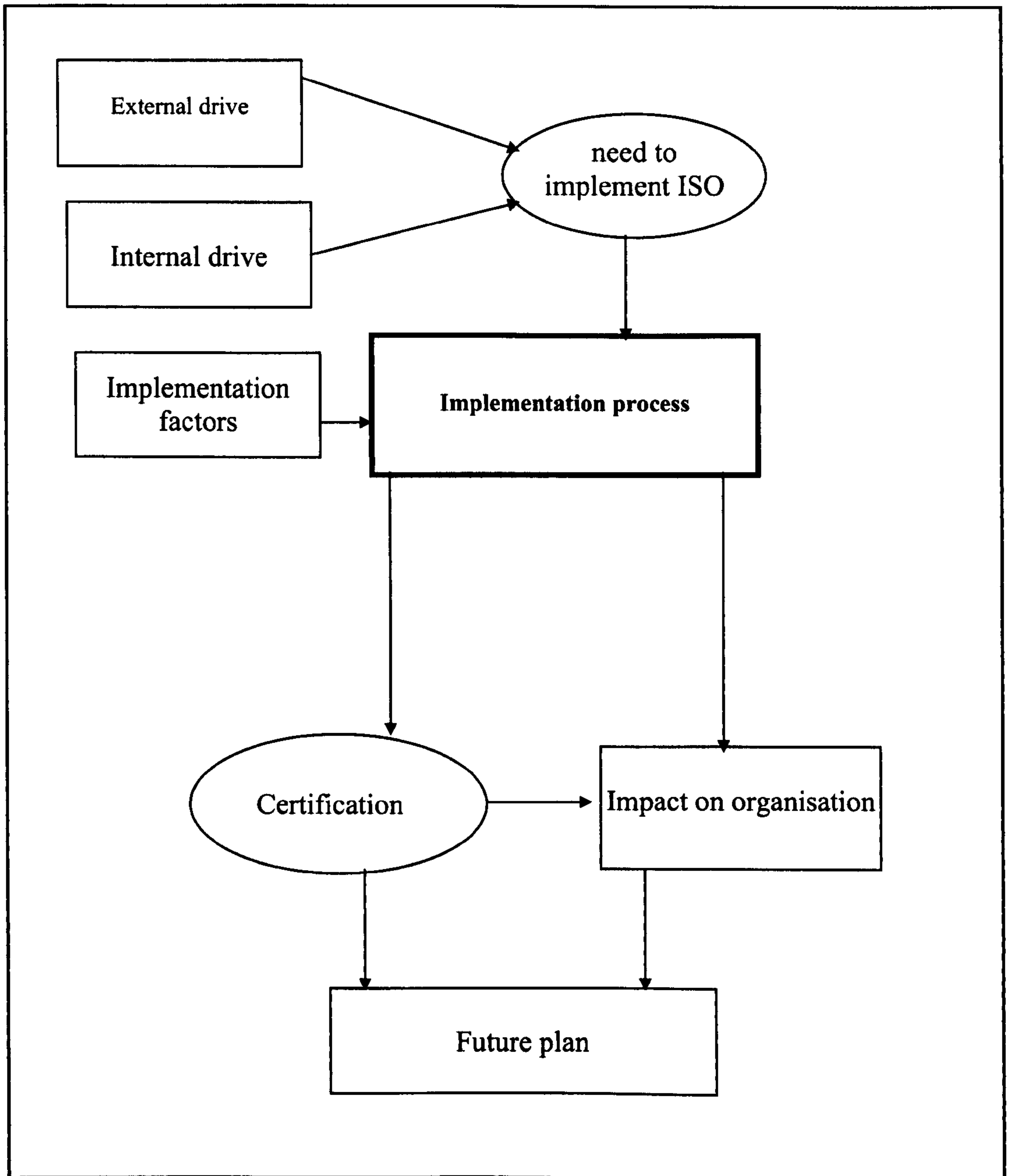

---

### 5.3.1 General implementation process guided by consulting team

In general the implementation process was similar among the companies due to the consultant's usual approach, illustrated as a flow diagram in Figure 5-3. However, each company had their own particular characteristics and style of working, which led to some differentiation of the implementation process among the companies. Table 5-2 shows some differential features of implementation among the five cases. At the start of the project, executive management, normally top management and the quality management representative (QMR) as well as quality team members, were provided with a training course giving an overview of the ISO 9000 series of quality systems standards and its requirements, including broad sense of the implementation process as well as methods of preparation and their responsibilities. At this stage, the top management and QMR were interviewed to obtain background information about their companies, the current quality system, the reasons (drivers) that made them decided to pursue ISO 9000, the obstacles they anticipated and how much they and their people knew about ISO 9000. They were asked to establish a steering committee which consisted of the executive management and was chaired by top management, and also to set up a working committee which contained representatives of every department involved with the ISO 9000 project. The first task of the steering committee was to establish a quality policy if they had not had one previously. In fact at the project start none of the companies had an explicit documented quality policy.



**Figure 5-3 General implementation process guided by consulting team**

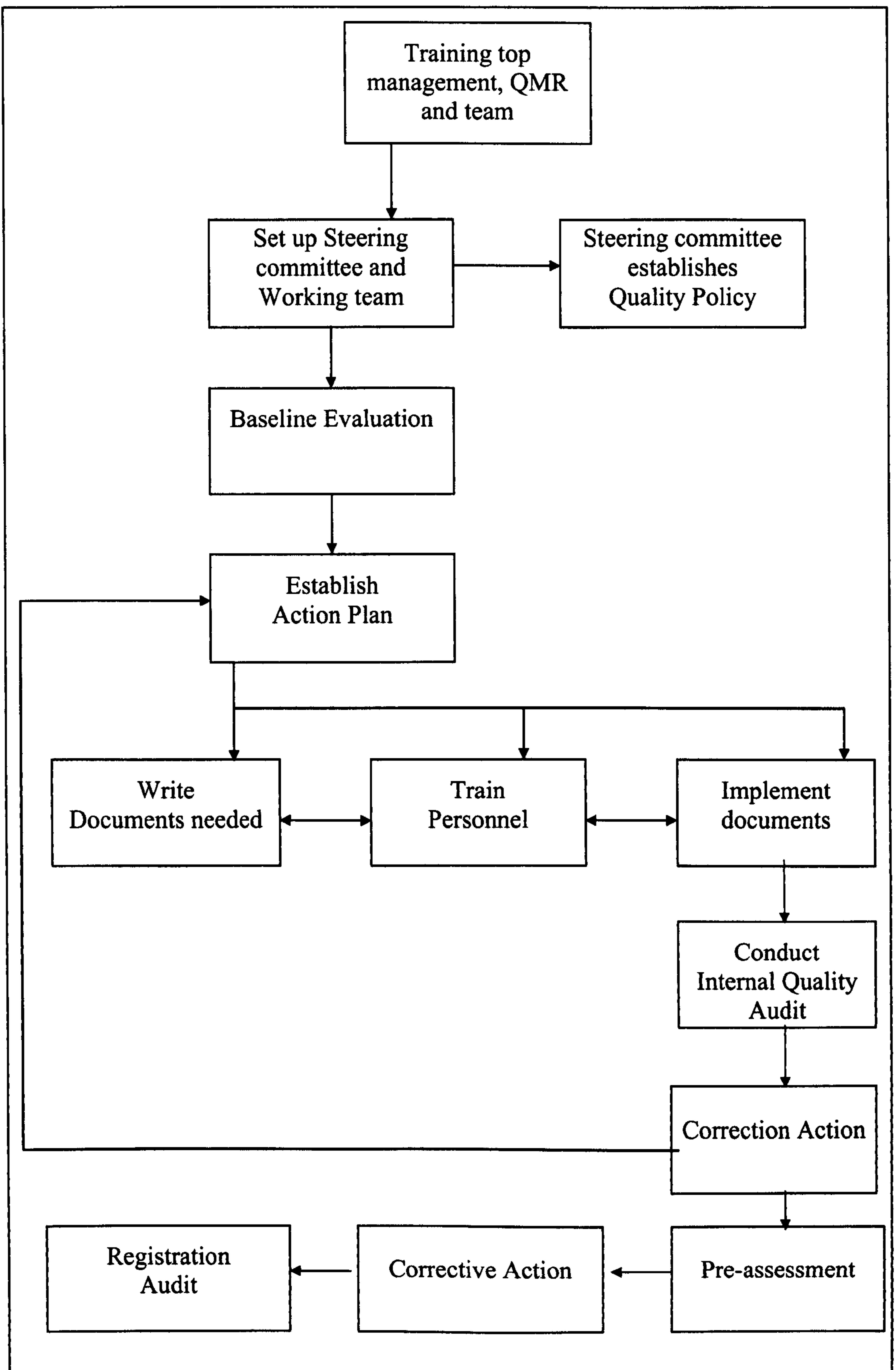

**Table 5-2 Some observations of implementation process in case study**

<b>Company</b>	<b>Drives</b>	<b>Expected obstacles</b>	<b>Speed</b>	<b>Continuity</b>	<b>Duration (months)</b>
I	Policy from top management Expand market Internal improvement (lack of problem traceability)	People problems (lack of training, low education level) Routine work occupies time of implementation	Fast	Continual	10
II	Seek reputation Seek support from government	Lack of manpower Full capacity of operation	Medium	Continual	16
III	Seek reputation Seek new knowledge for management system Want to conform to international standard	Change company culture Establishing documentation system	Fast	Interrupted	17
IV	Customer pressure Expand market share Internal improvement (there were no clear work standards)	Establishing documentation system Change company culture Low educational level – middle management	Slow	Continual	19
V	Expand market share Competitors start ISO 9000 implementation Internal improvement (Seek the system to help management)	Establish documentation system Low educational level – middle management	Slow	Interrupted	20



The consulting team together with the researcher conducted a baseline evaluation in each company during April 1997. They audited the companies against the ISO 9002 standard. Baseline evaluation reports (for example see appendix 5) were produced and reported back to each company. No company was close to compliance with the requirements of the ISO 9002 standard.

After the results from the baseline audit, the consulting team started working with the collaborating companies by visiting them, establishing action plans for particular companies. In the first visit after the baseline audit reports were submitted to the companies, the consulting team had meeting and worked with the QMR including quality team members to draw up the companies' key business processes, as a macro flowchart and assign responsibilities to members according to their functions.

The companies were required to send their working team to attend a workshop on the interpretation of ISO 9000 course and documentation course in order to understand the requirements of ISO 9002 and how to establish formal documentation system for their companies. They were left alone for one month to write their own documents according to the existing systems but now including the ISO 9002 compliance requirements.

The next step was to evaluate the documents they had prepared, as to whether they met the requirements of ISO 9002 standard. The documentation system which the companies established generally had 4 tiers (Figure 5-4): quality manual; procedures; work instructions; and supporting documents such as forms, records etc. Meanwhile, it was suggested to the companies that they

---

implement the documented procedures and work instructions they had written to ensure their applicability. The documentation process was an extended and tedious process for all companies since most of them were not familiar with working from formal documents. This step of getting document prepared and training staff on the procedures and work instructions they needed to use lasted more than two third of the project duration. However, the speed of the implementation process varied with companies as shown in Table 5-1. The details are provided in each company case analysis.

**Figure 5-4 Documentation structure in the companies**

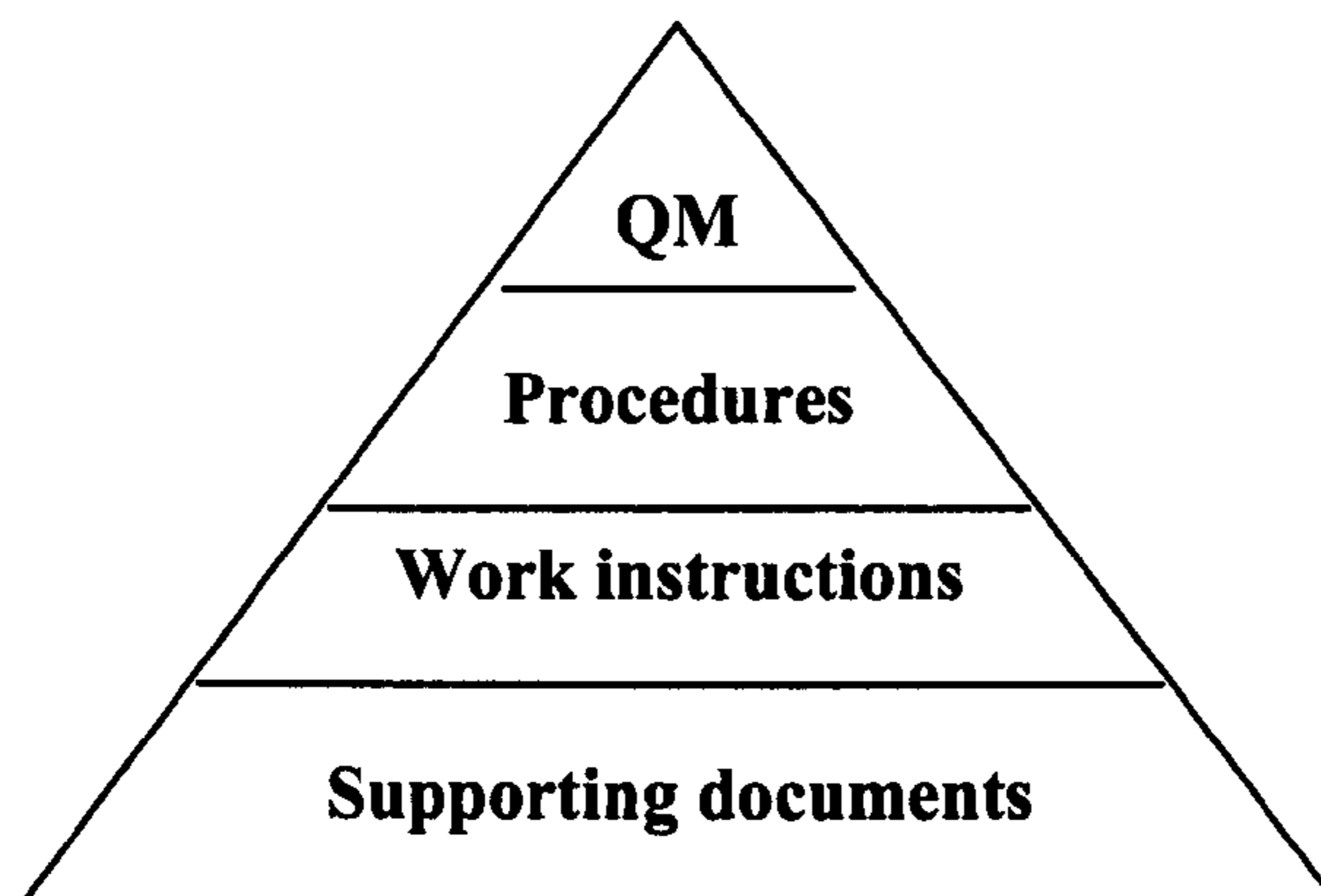

None of the investigated companies had ever had an internal quality audit system. Even though the companies did not have the system in place, the consulting team trained staff, appointed by management, to be internal quality auditors for their companies after an initial quality auditing training course. This allowed the companies to measure their progress on the documentation and implementation process by themselves and also to continuously monitor their quality system as required by the ISO 9000 standard (clause 4.17). Besides the training course, an internal quality audit



was planned and carried out by the consulting team with the companies' staff as trainees. This process was not very difficult for them, albeit they needed some time to practice.

The QMR, working team and NSTDA consulting team worked together closely during the long process of implementation. NSTDA team visited companies from time-to-times, as well as contacting them regularly by phone. The pre-assessment were carried out by another team of NSTDA staff (not the consulting team who helped the companies establish quality system) after the companies had quality system in place according to the ISO 9002 standard. After obtaining the audit reports on non-compliance, the NSTDA consulting team and the company working team worked together to undertake corrective action on every non-compliance found by the audit team. Finally, the companies contacted their chosen registration body and applied for the registration audit. An individual assessment of each company follows.

### **5.3.2 Company I**

Company I is a medium-size finished frozen food manufacturer with approximately 500 employees. It is also a wholly-owned subsidiary company of one of the biggest groups of companies in Thailand. It was established in 1988. Its production capacity is 4,000 ton/year.

It has two types of customer. The major customers are the superstores which are owned by the same mother company. The others are general customers most of which are stores located in petrol stations.

---

An organisation chart of company I is shown in Figure 5-5. Top management is called 'General Manager (GM)' in the quality manual. However, the Managing Director (MD) who is appointed by the central head office to look after this factory and other similar ones, is in charge of the factory overall. He comes to the factory twice a week. He initiated ISO 9000 project primarily so as to have a traceable system to trace back all problems which occur, and to be more competitive in the future market. He did not get involved in process implementation details of ISO 9000. Neither did the GM, although they were both supportive and always available to help solve problems when the QMR encountered difficulties. The steering committee and working group consisted of the managers from every department chaired by the GM. The work on the documentation and implementation process was done by this group.

The working group was very active, since the MD had a very explicit policy to achieve ISO 9002 registration within 1997. The working team worked very hard in documenting the quality manual, developing all procedures including work instructions within 6 months. After the internal quality auditors were trained, they practised and conducted the audits on their own to ensure that the quality system met the requirements of ISO 9000 standards.



**Figure 5-5 Organisation chart of company I**

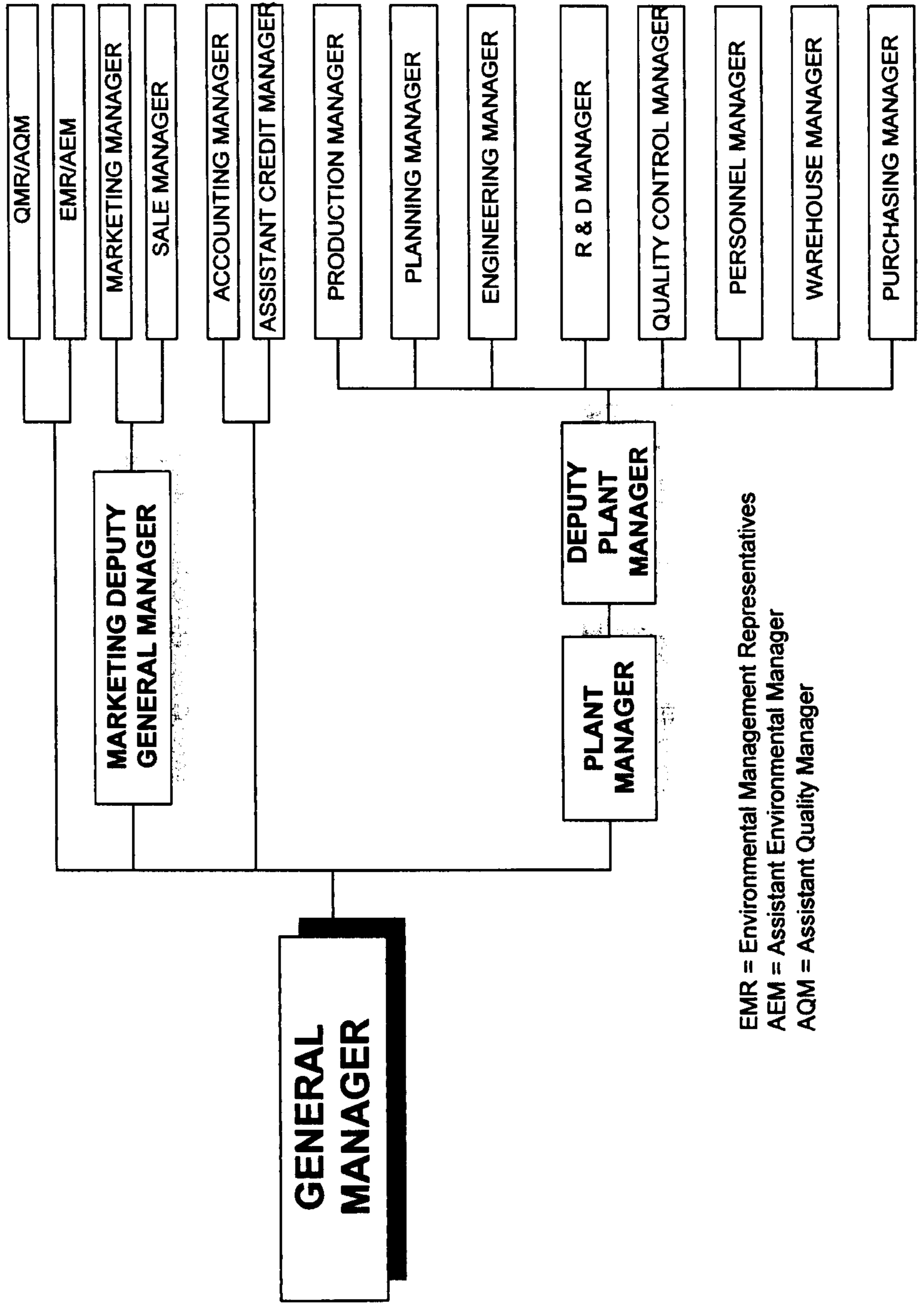

The NSTDA pre-assessment team conducted the audit at this facility after 10 months of the project. They found a number of non-compliances (NCs). The QMR and working team immediately corrected all the NCs. The company was certified in February 1998, ahead of the project plan and thus became the first company in the project to achieve ISO 9002 registration.

### **5.3.3 Company II**

Company II is a pharmaceutical manufacturer. They are a small company with only 80 employees. All the management are pharmacists, and this company was established ten years ago by a group of pharmacists. They did not have formal management system to run their business. The working environment was very friendly and all the members of the company, particular at management level, are friends. Figure 5-6 shows the organisation chart of the company.

This company joined the NSTDA support project because they sought support from government. They did not intend to implement ISO 9000 at first since they already had GMP (Good Manufacturing Practice) as required by the Thai FDA. They would not have attempted ISO 9000 implementation unless NSTDA had launched the project. Moreover, they did not have enough knowledge about ISO 9000 and the required budget etc., to hire a consultant. Even though they did not initiate the project by themselves, but they were very co-operative and active in working with NSTDA consultants. The MD of the company attended every training course as well as participating in all the

---



---

meetings with consultants and worked very closely with the QMR and quality team.

The process of documentation was difficult for them even though they already had standard operating procedures (SOPs) which are required by GMP. They spent almost a year getting all the documents done since the working team discussed widely and slowly to come to a consensus for each procedure. Routine work also caused the implementation process to slow. The MD then decided to establish a quality assurance department to bring the document centre and quality control section (QC) together. The company had difficulty in interpretation of the requirements of ISO 9000. They tried to make their procedures perfect, but afterward they found out that they could not implement them and they needed to revise and make their procedures implementable. The MD delegated the training and implementation process to each departmental manager. This strategy did not work because of the workload on the departmental managers. Hence, the document centre played very important role in co-operating with the lower level staff such as supervisors and line operators in terms of training and clarification of the points that they did not understand.

This company progressed as planned by NSTDA consulting team. They were pre-assessed in early July 1998. An audit team from the registrar conducted the audit in this company in November 1998. They identified a number of NCs. After the working team corrected those NCs, finally they were certified in late April 1999.

Figure 5-6 Organisation chart of company II

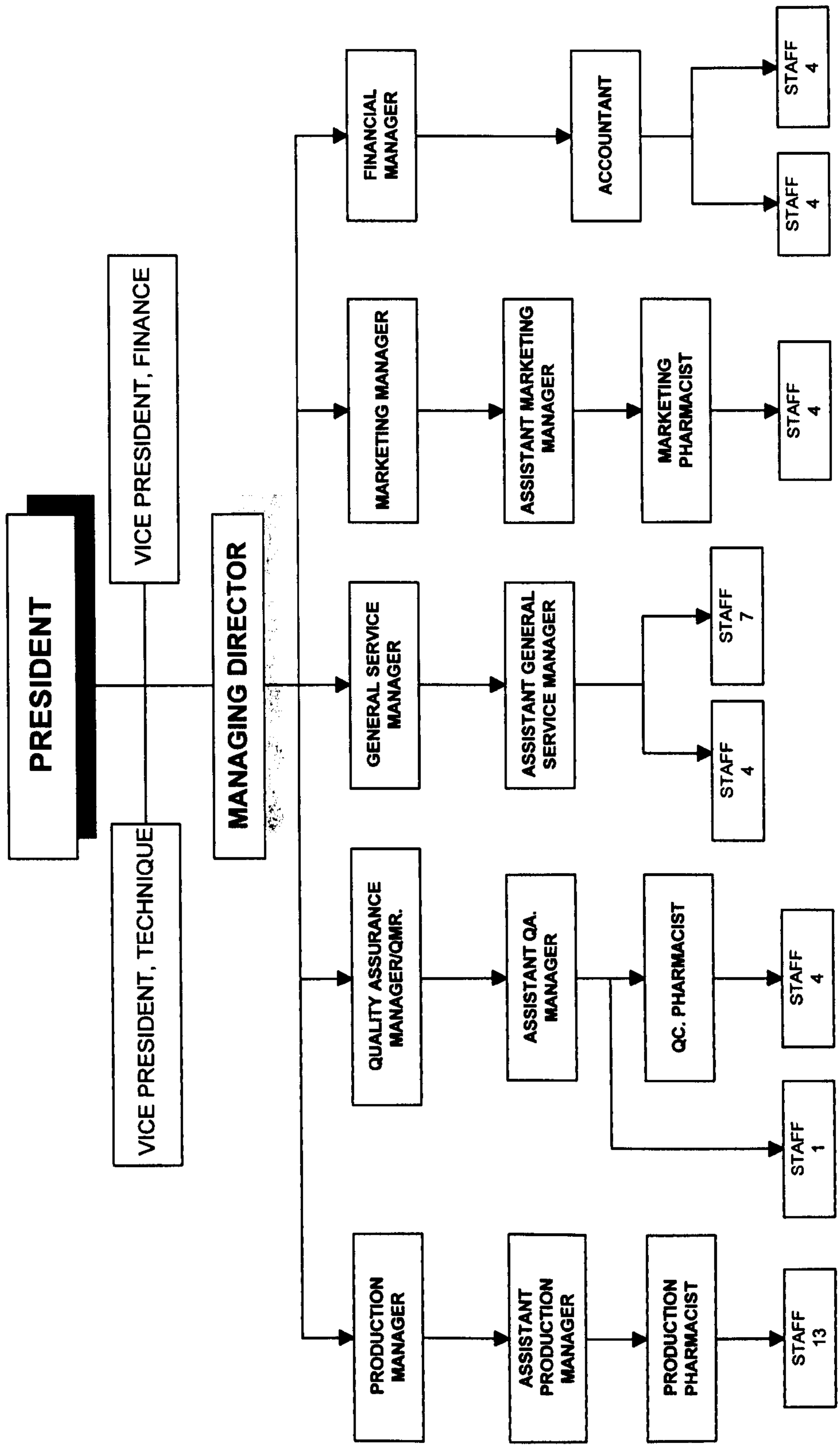



### 5.3.4 Company III

Although it is actually a joint-venture company, in many ways Company III represents a typical family business in Thailand. The Managing Director is part-owner who shares this air-conditioning manufacturing business with a Singapore associate. All functions need his authorisation. Every problem and anything which needs a decision must be referred to him. The QC function was not effective, and when the consulting team did the baseline evaluation they discovered that there were only 2 inspectors in the whole factory. They were also told that in peak season when there were high orders from customers these two inspectors would help on the production line, and then did not inspect products at all. However, this company was doing quite well in the air conditioner business. They act as supplier to many big-brand air conditioning companies in Thailand, and plan to have their own brand in the future.

The management team was active and worked well as a team. However their progress was very slow in the first half period of the ISO project because they had urgent production contracts. This stopped all work on the documentation of procedures for three months. They then established a QA department (Figure 5-7) and the manager of this department was appointed QMR to lead the ISO 9000 project. They also recruited several young engineers to work in production, QA and engineering departments, to supply more manpower and help set up the system.

---

Progress stagnated again in March and April 1998 because it was early summer and customers' demand for air conditioners had to be met. They started again in May and this time progress was fully satisfactory. The pre-assessment was conducted in August 1998, and they were finally certified to ISO 9002 by the registration body in late September 1998.



Figure 5-7 Organisation chart of company III

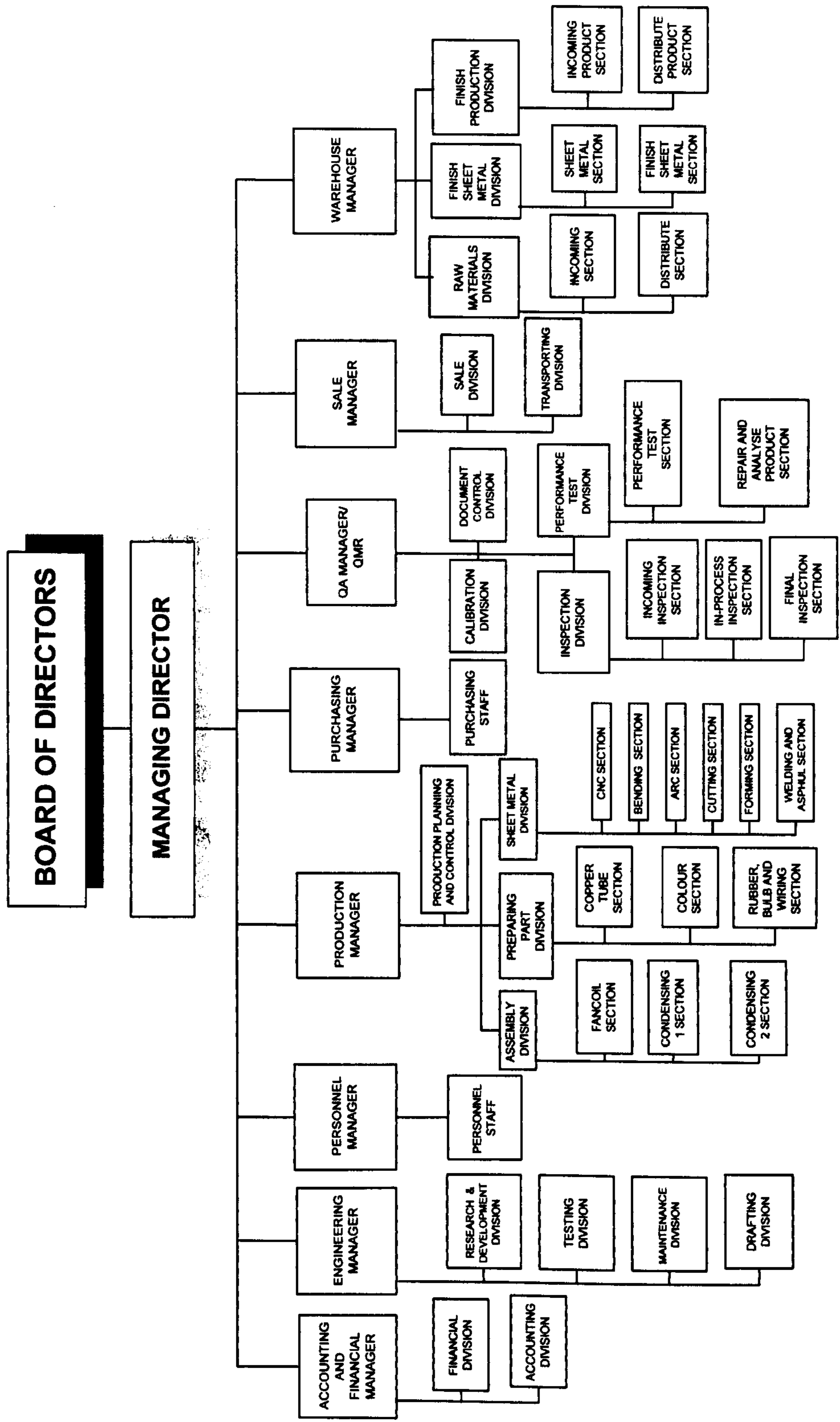

### **5.3.5 Company IV**

Company IV manufactures the heat exchangers which are a vital component in air conditioning systems. This company had been interested in ISO 9000 for more than a year. The top manager attended an ISO 9000 introduction course. He then sent his departmental-level management staff to be trained in the ISO 9000 series of quality systems standards. In-house training courses focusing on the requirements and implementation process of ISO 9000 were organised in order to provide general knowledge of ISO 9000 to middle management in the company.

Documentation was very long process for this company - they took more than 12 months to get all the systems documents prepared and implemented. Conflicts among management staff often occurred during the consulting process. The engineering departmental manager (in Figure 5-8) was appointed to be QMR since the QC section was part of his responsibility. The departmental managers were trained to be internal quality auditors for the company. They did not find the audit process easy. However the Company IV was pre-assessed by the NSTDA audit team in October 1998 and successfully certified in December 1998.



Figure 5-8 Organisation chart of company IV

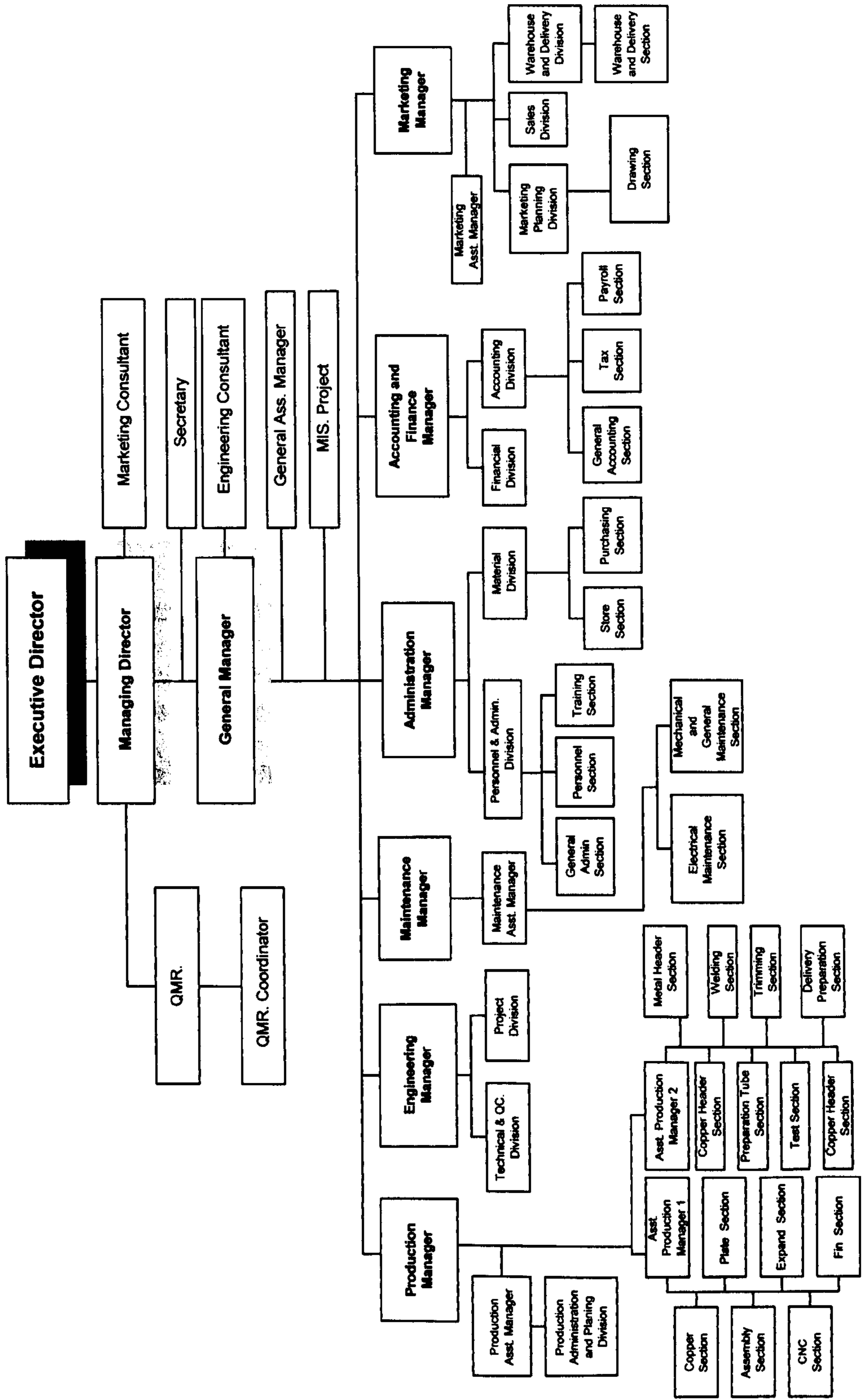

### 5.3.6 Company V

Company V is family business rather like Company III, producing lighting fixtures and trunking for cable support. The company has been driven by four young businessmen. The rest of the managers have been promoted from technical and skilled worker levels. Hence the middle management level, shown in the organisation chart in Figure 5-9, tend to have low educational levels. The company had neither a formal management system nor a quality assurance system. They performed no incoming inspection or in-process inspection, although they did have final inspection to check all the finished products. The factory is located in a very limited area which made it very difficult to arrange good storage of raw materials or finished products.

Owing to questions from their customers about the quality system in use in the company, the ISO 9000 series of quality systems standards came into their mind. They contacted a private consulting company which proposed a consultancy package costing close to a million baht. The company could not afford such expenditure at that time. NSTDA support project was a good choice for them since it cost them only a quarter of the commercial rate.

The documentation and implementation processes were extremely slow in this company. It had never had a formal quality system before, and there were only four directors who could follow all the training materials and consulting team's suggestion. Moreover, they have two main categories of product which are required the company to document the manufacturing processes separately. The production managers of both lighting and trunking

---



departments were very slow to develop the documentation although they were technically very competent at producing their products.

The company was well behind the schedule set by the NSTDA consulting team. After some initial unsuccessful work, three quality teams were set up which consisted of representatives from various departments. Each team was led by one of the divisional directors. These cross-functional teams developed a more effective strategy to document and implement the ISO 9000 requirements. In November 1998, the NSTDA pre-assessment team conducted the audit. Corrective action had been taken and the company was finally certified in February 1999.

Figure 5-9 Organisation chart of company V

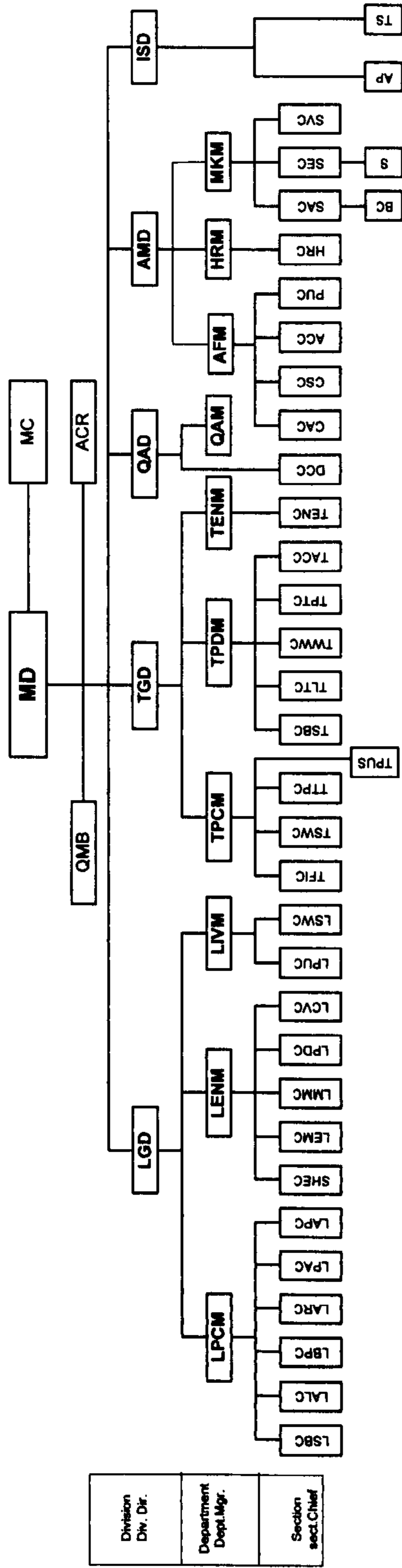

Code	Position
MD	Managing Director
ACR	Accounting Counsellor
MC	Management Committee
QMB	Quality management Board
LGD	Lighting Div. Director
TGD	Trunking Div. Director
QAD	Quality Assurance Div. Director
AMD	Administration Div. Director
ISD	Information System Div. Director
LPCM	Lighting Production Control Dept. Manager
LENM	Lighting Engineering Dept. Manager
LVM	Lighting Inventory Dept. Manager
LSBC	Lighting Shearing & Blanking Sect. Chief
LALC	Lighting Aluminium Sect. Chief
LBPC	Lighting Body & Part Sect. Chief
LARC	Lighting Arc Sect. Chief
LPAC	Lighting Painting Sect. Chief
LAPC	Lighting Assembly & Packing Sect. Chief
SHEC	Safety, Hygiene, & Environment Sect. Chief
LEMC	Lighting Electrical Maintenance Sect. Chief
LIMMC	Lighting Mechanical Maintenance Sect. Chief
LPDC	Lighting Product Development Sect. Chief
LVCV	Lighting Civil Sect. Chief
LPUC	Lighting Purchasing Sect. Chief
LSWC	Lighting Store & Warehouse Sect. Chief
AFM	Accounting & Financial Dept. Manager
HRM	Human Resource Dept. Manager
MKM	Marketing Dept. Manager
TPDM	Trunking Production Dept. Manager
TPCM	Trunking Production Control Manager
TENM	Trunking Engineering Dept. Manager
TSBC	Trunking Shearing & Blanking Sect. Chief
TLTC	Trunking Ladder & Tray Sect. Chief
TWWC	Trunking Wire Way Sect. Chief
TPTC	Trunking Perforate Tray Sect. Chief
TACC	Trunking Accessory Sect. Chief
TFIC	Trunking Finishing Sect. Chief
TSWC	Trunking Store & Warehouse Sect. Chief
TTPC	Trunking Transportation Sect. Chief
TENC	Trunking Engineering Sect. Chief
QAM	Quality Assurance Dept. Manager
DCC	Document Control Sect. Chief
CAC	Cashier Sect. Chief
CSC	Costing Sect. Chief
ACC	Accounting Sect. Chief
PUC	Purchasing Sect. Chief
HRC	Human Resource Sect. Chief
SAC	Sales Administration Sect. Chief
SVC	Sales Executive Sect. Chief
TPUS	Trunking Purchasing Staff
BC	Bill Collector
S	Salesman
AP	Application Programmer
TS	Technical Support Staff



---

## **5.4 Drives for pursuing ISO 9000**

As shown in Table 5-2, the requirement for ISO 9000 implementation in Thai companies arises from both external and internal sources. A study from the Thailand Productivity Institute (TPI, 1998) and the survey results from this research presented in Chapter 4 both concluded that the primary motives which persuade companies to go for ISO 9000 series standards are the need to improve organisation and work systems; to enhance competitiveness; and to pave the way for quality improvement and TQM. It should be noted that the companies responded to these surveys after they had the quality system in place. In this study, which is based on action research, initially, even the management levels of the companies concerned had little knowledge about ISO 9000, they saw the standard as a tool to expand market share and get a better reputation. However, after they had been implementing an ISO 9000 system for some time they realised the potential and sought ways to obtain the most benefit from the standard.

### **5.4.1 External drivers**

For the companies studied, the main initial drivers were external influences. As mentioned before, ISO 9000 series of quality systems standards has been adopted as a Thai national standard since 1990, and has become well known among Thai manufacturers. However, at first the companies knew of the ISO 9000 standards mostly as a 'reputable mark' which could help them get into new markets as well as gain more competitive advantage over their competitors. As described in Chapter 4, the companies which need the

---

---

certification because of their customers' demand tended to have gone through the implementation process at the early stage after ISO 9000 quality systems standards was adopted in Thailand. Typically, if the companies are not exporters, they were not forced by their customers to get ISO 9000 registration. Although ISO 9000 has been Thai national standard for almost a decade, its chain effect has not reached local manufacturers yet. Most customers do not demand ISO 9000 registration even though customers which have been certified might start to encourage their suppliers to have some kind of formal quality system.

After ISO 9000 became the Thai national standard, government institutes such as Thai Industrial Standards Institute (TISI) launched a quality campaign to make people more aware of the importance of quality. Thai companies were convinced by the government campaign that ISO 9000 is a quality systems standards which could help them be more competitive and stay in business. The support project provided by NSTDA is also one of factors that motivated Thai companies to go for ISO 9000 in spite of the fact that they may have known very little about it. But after implementing the system, many companies realised that they had gained more benefits than they expected. This illustrates how government promotion and support can play an important role to help local industry pursue ISO 9000 in developing countries.

#### **5.4.2 Internal drivers**

The companies' internal need for a formal quality system is also a driving force for them to implement ISO 9000 standards. Most have suffered



from various quality problems such as delivery of incorrect products, recurrent and persistent quality loss, and non-conformance, no work standards, etc. These internal problems are one of the main reasons for the introduction of a quality management system. Some companies identify this need after they have been implementing an ISO 9000 quality system for some time. The standard and its requirements can uncover problems which they did not recognise before.

### **5.5 Implementation process**

As described in section 5.3.1, the implementation process in general consists of the six main steps of training, documentation, implementation, internal quality audit, corrective action and registration audit. This section explains how the implementation process progressed under various conditions. In particular the speed of the process and the progression style. These are shown in Figure 5-10.

**Figure 5-10 Progression speed and style of ISO 9000 implementation**

	<b>Progression Style</b>	
<b>Progression Speed</b>	<b>Fast-continual</b>	<b>Fast-intermittent</b>
	<b>Slow-continual</b>	<b>Slow-intermittent</b>

---

Following the iterative three-step procedure of grounded theory described in Section 5.2, cognitive mapping (see Appendix 4) was used to identify categories and tentative relationships between them. To form these connections between categories, the paradigm model (Figure 5-1) was used, resulting in the framework of ISO 9000 implementation shown in Figure 5-2. The ISO 9000 implementation process was identified as the core category, because it represents the primary phenomenon (i.e. what actually happened). The properties and dimensions of each category emerged from the data in cognitive maps and the descriptive data described in section 5.3.1-5.3.6.

There are several possible properties of the implementation process which might be identified as significant. These include the success in achieving ISO 9000 registration, excellence of the approach used, the efficiency of the documentation developed, etc. All the case study companies successfully achieved the ISO 9000 certification. Many of these properties were effectively held constant in this study, through the use of the same implementation approach administered by the same consultancy team in each collaborating company (i.e. the same advice on documentation, etc.). The basic loop of internal audit and corrective action (Figure 5-3) was the same in all companies. Hence, variations in the implementation process were considered to result primarily from differences in the company responses rather than from differences in the consultancy process.

To develop a theory, it is necessary to identify significant properties of the core category which are sufficiently simple to be understandable, perhaps

---



---

even measurable. The actual steps of the implementation process (Figure 5-3) and the timeframe identified in the consulting plan (Appendix 2) were used as criteria to measure how well the five companies progressed. Initially, the companies were expected to follow the plan exactly. It soon became obvious that speed and progression style were different between the five companies.

Although the consulting team used the same approach to work with all participating companies, these companies progressed differently in terms of speed and continuity of progress, as individually described in Section 5.3.2-5.3.6. Some companies were proactive and able to take further steps in implementation without waiting for the consultants' visit while others had difficulty and needed more consultancy time. It was also clearly observed that some companies had to stop working on the ISO 9000 project for various business reasons while some others were able to progress continually. (It should be noted that the implementation process was carried out during a serious financial and business crisis in the Thai economy.)

The speed and progression style were next classified by dimensional level. The dimensions of speed ranged from 'slow' to 'fast' and those for progression style were characterised from 'continual' to 'intermittent'. Hence, four types of ISO 9000 implementation process were identified. These are fast-continual, slow-continual, fast-intermittent and slow-intermittent implementation processes. These implementation types are described below.

### **5.5.1 Fast-continual implementation**

The implementation process in this type progresses well. The company normally has very strong teamwork. Team members operate at high management levels and have enough authority to ensure progress of the project, and generally are departmental managers or second level management who report directly to top management. They tend to be highly committed to the project. There is little conflict between team members, if they have disagreements they try to resolve them by discussion, and make decisions without delay. They put top priority on the project. Although they continue to do their routine work which must be finished in time - for example products must be delivered every day - they are willing to work in the evening or weekends to prepare documentation and accomplish their goal according to their plan.

A QMR will be appointed by top management to be responsible for establishing and maintaining the quality system. The QMR will be very active and knowledgeable about the company systems as well as ISO 9000 requirements. He/she is the quality champion of the company and acts as an internal consultant to help other team members. He/she works closely with professional consultant, if they have hired one. The QMR can be anyone operating at management level, even though the QA manager is normally appointed.

Top management in this implementation type has an explicit plan and a strong determination to achieve targets. He/she gives strong policy guidance

---



to the working team to achieve registration in the planned time frame. Even though he/she does not get involved in the detail of the implementation process, but is very supportive and available to help the team at all times when they struggle with problems.

Normally, the company in this type set up their quality system in a short time. On one hand, they achieve their goal quickly, but on the other hand their system may still need to be improved. There may still be problems occurring, for example the operators do not follow their work instructions due to lack of understanding of the new system. But after the system has been in place for a period of time and the workers have gone through an audit process a few times, they will understand the system requirements. Then the quality system can be effectively maintained.

### **5.5.2 Slow-continual implementation**

A company which belongs to this category will spend a long time to set up their ISO 9000 quality system, but without significant interruption. The team members work together to progress the project slowly but continuously. The team members may typically discuss widely and freely until they have a consensus, which sometimes take several meetings. The loop of documentation, training, implementation, internal quality audit and corrective action (in Figure 5-3) may be repeated many times in order to ensure that the established system works. Conflicts among the working team are one of the factors which tend to slow the implementation process.

---

The QMR is at the heart of the project because he/she needs to lead the team which is setting up the quality system. Where relative equality of status or position exists between working team members, it is sometimes difficult to avoid conflict and subsequent delays. The QMR may need to seek help from top management to solve this kind of problem. In other cases the QMR holds a senior management position but delegates the organisation of the development work to an assistant. Sometimes the assistant does not have the authority to push other team members to work as planned. However, this type of company will finally achieve their goal even though perhaps later than they planned.

### **5.5.3 Fast-intermittent implementation**

The progress of the implementation process in this type of implementation is often interrupted by other work, such as urgent production, ad hoc projects, etc. Although the spirit of teamwork is high and the company is committed to the ISO 9000 project, the core business comes first. They may need to stop ISO 9000 work - sometimes for 1 or 2 months - to put all available manpower onto another more important project. Typically the working team consists of high level management (probably departmental managers) who have full authority to progress the implementation process within their areas. After they return to work on ISO 9000 project, they will make rapid progress. In this style it was observed that, lower management level may be less involved in documentation of procedures and work instructions. They are trained to work according to their work instructions,

---



---

which means that the workforce does not take such an active development role but rather a receptive role in the system.

When progress is rapid, it implies that the working team led by the QMR is co-operative and works together closely. The QMR plays a very important role to facilitate team working, probably with the assistance of a professional consultant. Top management will also be constructively involved in the project providing support and resources.

Despite interruptions to the implementation process this type of company eventually accomplishes their aims and gets ISO 9000 registration.

#### **5.5.4 Slow-intermittent implementation**

There are many obstacles in the implementation process in this style of implementation. The progress is always slow but also stagnates from time-to-time. Here the working team typically consists of middle managers, who although officially departmental managers do not have full working authority. The real decision-making power is in the hands of higher management levels. In such a company in Thailand, which is frequently family-owned, such middle management may well have been promoted from supervisory levels, and may be of limited intellectual calibre and educational achievement. They typically have little knowledge of management issues, and learn slowly. They spend very long periods of time just learning about management systems and ISO 9000 requirements, not to mention the documentation and implementation process.

---

With such a team there may be a gap between the QMR and the others in terms of knowledge, education and authority. Team members will be reluctant to take initiatives to plan and help progress the project, acting as 'followers' only. Therefore it is quite difficult for the QMR and top management to encourage them to work effectively. They spend long period of time trying to solve problems and train their working team. And because the project depends entirely on the QMR, when he/she is unavailable, perhaps working on other business, no progress is made.

However, as the case studies show, even in this type of company, a quality system according to ISO requirements may ultimately be set up and company achieves success in the registration audit.

### **5.6 *Implementation factors and obstacles***

There is no universal implementation process plan that is right for every company. The plan of each company uniquely reflects its choice of target registration date, its initial state of compliance with the ISO 9000 standards, and the resources it has available for the project (Huyink, 1994).

However it might be expected that Thai companies implementing ISO 9000 would face some common obstacles. The TPI study (TPI, 1998) reported from their survey that the most common difficulties encountered by Thai companies were 'interpretation of ISO 9000 requirements; documentation system; commitment of management; co-operation from workforce and change of working procedure'. The longitudinal case studies

---



described in this thesis provide more insight into the obstacles faced by the investigated companies. The general implementation factors are identified from the case studies and then the explanation of the obstacles in a Thai context is described.

### **5.6.1 Teamwork**

As will be understood from the preceding sections of this chapter, teamwork is the most important factor in implementing ISO 9000 quality systems. Since the ISO 9000 standards imply a need for communication and therefore teamwork (Merrill, 1996), the implementation process depends very much on this factor. As described in 5.5, the effectiveness of teamwork notably influences the speed of the implementation process. It can be concluded that the human elements involved in an ISO 9000 quality systems development project are as important as the technical elements (Huyink, 1994).

### **5.6.2 Top management**

The project can never be successful unless there is support and commitment from top management. Unlike TQM implementation, in which top management needs to be intimately involved and drive the project, top management does not really need to get involved in details for an ISO 9000 implementation process. They need not know or understand all of the details of ISO 9000 requirements. However, they must show leadership and commitment to the project, being supportive and available to help their people if required.

---

---

### 5.6.3 Workforce

The workforce may get involved in documentation process but in these 5 case studies they were responsive rather than active. In each case they operated according to work instructions that the working team or their superior prepared, since they were not able to write their own documents due to low educational levels. Resistance from the workforce can inhibit progress of the implementation process. Fear of change is often found in the workforce, the management should understand this factor and communicate with their employees to resolve any misunderstandings they may have.

‘The ISO 9000 registration project is not just writing a quality manual, authoring a pile of procedures, and carrying out a list of technical tasks. It is also working with people.’ (Huyink, 1994)

### 5.6.4 External influences

External influences can help or hinder the project. For example, the Thai financial and economic collapse started in July 1997 while the investigated companies were implementing ISO 9000. The consequences spread quickly throughout the commercial and industrial sectors. The case-study companies were effected both positively and negatively. In some companies, they acted to ensure survival first by seeking more customers, and moving to short time working to reduce cost. Hence the ISO 9000 projects tended to stagnate until the companies were stable. Fortunately, all five companies were not seriously affected by the national economic failure. On the contrary, this affected the motivation of all employees to work as a team,



---

and helped them realise the importance of the quality system standard they were implementing.

### **5.6.5 Thai companies - Language difficulty and interpretation**

As reported by the TPI (1998) study, the interpretation of ISO 9000 requirements is one of the problems Thai companies face. This problem is also reported by several studies (Carlsson and Carlsson, 1996) even in English speaking country such as USA (Alcorn, 1995) and Australia (Brown and Wiele, 1995). In all the case studies it was discovered that the interpretation of ISO 9000 requirements is a major problem the companies encounter. This is not only because of the difficulty of interpretation by itself but also because the standard used is in the English language. Although adopted as a Thai National Standard, the ISO 9000 series standards have not been translated into the Thai language. As regards the case-study companies, the problem was not reduced as a key NSTDA consultant involved with the project was a US citizen who did not speak Thai. In general the language issue causes some difficulty to practitioners and industrialists who normally prefer to use their mother tongue. Many educated Thai in business have some ability in written and conversational English but not sufficient to understand the standards clearly. This has led to strong demand for good consultancy services which can help companies interpret the standards and also provide them with quality management expertise and knowledge.

### **5.6.6 Thai Infrastructure**

Unfortunately, since quality management as well as ISO 9000 quality systems standards are both relatively new issues in Thailand, there are few competent professional consultants. It is expensive to hire one to help a company establish its quality system.

Another important obstacle the companies encounter is the support system of calibration for measurement and inspection instruments, as required by ISO 9000 standards. It is a national problem for Thailand that it lacks comprehensive support systems for calibration (Sripaipan, 1994). There are fewer than 10 calibration laboratories to provide traceable calibration service in Thailand, and the coverage of all possible requirements is not complete. Therefore companies sometimes need to send their equipment to be calibrated abroad. It costs a large amount of money and also takes a lot of time.

### **5.7 *Impact of implementation process on company organisation***

After the companies have been through the implementation process, not only the system but also other elements of management and organisation will have been changed. Kehoe (1996) points out that ISO 9000 has its major impact on organisations which are in the early stage of quality development, and especially it has had a significant affect on SMEs which are not necessarily seeking world-class status. In fact, it is often quite difficult to determine the entire scope of the impact of ISO 9000 implementation on companies since the system has only just been set up. However, the changes

---



in organisation which occurred gradually during the project were observed. The reversed cause-effect diagram in Figure 5-11 demonstrates the observed impact of ISO 9000 implementation on the organisation. Four aspects of impact which are induced by ISO 9000 implementation process are identified. These are structural, process, cultural and management change.

**Figure 5-11 Reversed Cause-effect diagram of impact of ISO 9000 on organisation**

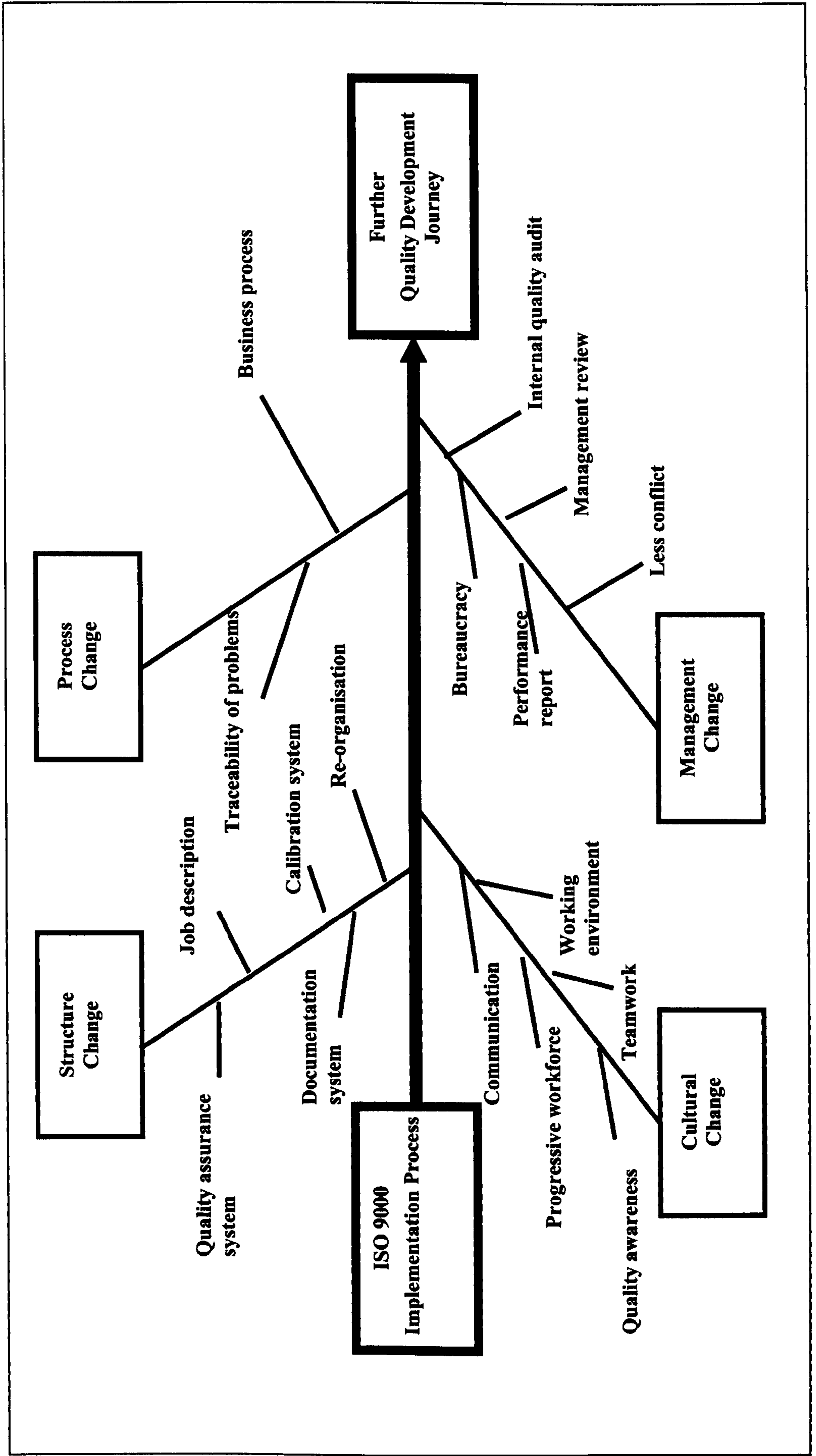



### 5.7.1 Structural change

As at the beginning of the project, most of the case-study companies did not have a formal **documentation system**, ISO 9000 has provided a very useful general guide for them to start working with formal systems. They now have a quality manual which describes the quality system of their companies and refers to documented procedures and work instructions in the system. All the documents provide good guidelines for operators to perform their specified job effectively.

‘ISO 9000 provides a strong measure of confidence that the firm has a systematic process to deliver on its contractual promises. ISO 9000 documents what is expected, makes indoctrination and training more useful, and serves as a knowledge-transfer tool within the existing and expanding work force of your firm. ISO 9000 verifies that what is intended really happens....consistently!’ (Hayden, 1996)

Since the companies did not realise the importance of calibration before, clause 4.11 (Control of inspection, measuring and test equipment) shows them the importance of this area. Typically they did not identify and had no control system to calibrate or recall equipment which needed to be re-calibrated. If they did, it was not traceable to established national or international standards. Hence, ISO 9000 has brought **calibration systems** which are very important in manufacturing industry into their normal operation.

Some of the companies did not previously have a **quality assurance** department, although all had an inspection or test function. The ISO 9000

---

---

quality standards do not actually require companies to have such a department, but the companies themselves realised that they should have a responsible department to plan and maintain their quality system. Clause 4.2 (Quality System) implies this change.

**Job descriptions** in organisation were normally revised and therefore became more clear to everyone in the companies. The middle management became more aware of the skill or competence of operators when they wanted to allocate tasks work. Hence the operators will be provided with training before they are allocated a new job.

Some companies reviewed and then revised their **organisation structure** when they started implementing an ISO 9000 series quality system. Some departments were merged with other and some were split. The QMR is a new position but usually held by a manager who already has the main responsibility for quality.

### **5.7.2 Cultural change**

**Quality awareness** among employees has been raised due to the ISO 9000 climate since the project started. After top management announced companies quality policy, all employees are required to know, understand and implement it through their work position (clause 4.1). Moreover, the internal quality audit (clause 4.17) is conducted at appropriate time intervals as required by ISO 9000 standards. The workforce of companies has a reduced fear of change (the '**progressive workforce**') in such an organisation because



they have gone through the process of ISO 9000 implementation and are now used to change.

Working as a team is at the heart of the implementation process, and after the companies has successfully been certified according to ISO 9000 standard, this helps **teamwork** to become the spirit in the company. Also as the companies provide considerable training to and must interact with employees to educate and communicate with them on ISO 9000, the management then discover that they have better **communication** with their workforce.

ISO 9000 quality systems standards also helps to induce a good **working environment** because the companies find that poor housekeeping and unsafe working practices are exposed for what they are when a more effective approach is taken to systems, product, non-conformance, etc. as required by the standards.

### **5.7.3 Management change**

ISO 9000 evokes changes in management in the organisation. The management now holds **management review** meeting at regular interval time to ensure the effectiveness of their quality system required by clause 4.1.3. In fact, management did have meetings before they implemented ISO 9000, but these were informal and they did not explicitly discuss or review quality issues. The companies have now identified various quality measuring indices, such as reject rate, % rework-repair, etc. The departmental managers now come to management review meetings with their **performance reports** in

---

---

order to demonstrate the efficiency and effectiveness of their department, discuss problems and brainstorm to find solutions. **Internal quality audit** (IQA, clause 4.17) is also one of the new systems required by ISO 9000. It helps management level follow up all of the problems which have occurred in the system. As the IQA report is objective and it is conducted by independent internal auditors appointed by top management or the QMR, it is the opportunity for a particular department which is audited to improve their work.

As mentioned in section 5.7.1, the companies have set up formal documentation systems which are helpful, but on the other hand, as their system become more complex, they become less flexible and therefore **bureaucracy** can be a problem. However, they do not view it as disadvantage, the system is set up by them so as to help them work effectively. They now have sufficient knowledge to deal with quality system and are able to change if required.

After they have implemented their ISO 9000 quality system, companies will have job descriptions, documented procedures and work instructions which provide guidelines for operators. All of these help **reduce conflict** among management in work since they have standard working procedures to refer to.

#### **5.7.4 Process change**

Four out of five companies in this study changed their **business processes** after they implemented ISO 9000. There were no major changes in

---



terms of workflow to produce their products or in technical issues, however, the companies reviewed their business processes and make some changes in terms of administration. Some companies which never had quality assurance department established one and therefore this department became responsible for quality planning. The companies which used to receive customer orders through the production manager or engineering manager have changed this process to route orders through marketing or sale departments. And because they have set up the system according to the requirements of ISO 9000, now they can **trace back the problems** occurred in their organisation and ensure that the responsible or concerned department take corrective action (clause 4.14) and management level must follow up until the problems have been resolved.

### **5.8 Future plan**

After the case-study companies had successfully set up their ISO 9002 system, they all now looked forward to new challenges. They have become more confident to move forward towards more advanced programmes or approaches. Either ISO 9001 or the environmental standard (ISO 14000) could be the next choice. Some companies started to look at the possibility of continuous improvement programme or TQM. It was recognised that the current ISO 9000 series of quality systems standards in itself did not provide for procedures to improve quality. But it does articulate good quality practices that are an essential foundation for building continuous quality improvement capabilities. (Peach, 1996 and Hayden, 1996)

Some companies were aware that they needed more involvement of shop-floor operators. They began to think about QCC and 5S, and some considered that had they started with those basic people-oriented quality improvement tools, they would have achieved better results with their ISO 9000 implementation.

### **5.9 Summary and conclusions**

This chapter has presented the results of a qualitative analysis based on five case studies of the implementation of the ISO 9000 series of quality systems standards. The driving forces which encourage Thai industry to pursue ISO 9000 come from both external and internal influences. They are first persuaded by external influences, such as customers and markets, but after they learn more about the system and its internal benefits, they gain motivation to establish an effective system. Apart from the well-known international acceptance of the standards, incentive and support from government are the main drivers for companies to pursue ISO 9000.

Owing to their initial low level of quality-related knowledge, many Thai companies need help from consultants. Teams which involve the right levels of management plays a very important role in the implementation process. Top management is also important in terms of leadership and support. Working with documentation is one of the problems in ISO 9000 implementation for Thai companies, especially SMEs. If the companies which are implementing ISO 9000 quality systems go through the process of implementation conscientiously, their organisational culture is gradually

---



changed because an effective implementation process requires the involvement of employees and an improvement of their understanding of quality. The impact of the implementation process on organisation is demonstrated through a reversed cause-effect diagram which identifies structural, cultural, management and process change. Finally after companies have the ISO 9000 series quality, their knowledge and competence are improved , and they are likely to wish to progress on their quality journey in one way or another.

## **6. The adoption of TQM in Thai industry**

### **6.1 Introduction**

It has been accepted worldwide that one of the key factors for companies to be successful in the global market is quality. As described in chapter 2, in developed countries such as the UK, USA and Japan, TQM has been a topical issue for many years in all business sectors, particularly manufacturing industry. However, in a developing country like Thailand, even though it has successfully developed substantial manufacturing industry in the last few decades, TQM has made little impact. The results of the survey in chapter 5 indicated that the main emphasis in recent years has been on ISO 9000 series implementation. Only a few companies have developed a TQM approach. With the exception of a handful of large Thai-owned groups, TQM has been adopted primarily by foreign-owned companies within the electronics sector.

As a TQM philosophy takes a broader approach than ISO 9000, and its implementation can be achieved in various ways, it was of interest to examine how Thai-based companies have adopted TQM. In particular, as both Japanese and US companies have been major investors in Thailand (Tambunlertchai, 1993), the aim of the study described in this chapter was to

---



compare TQM implementation within three ownership types: Thai, Japanese, and US-owned companies operating in Thailand.

This chapter provides an insight into TQM implementation in Thai industry. A theoretical framework for TQM implementation is described and used. The data collection and method of analysis used in the case studies are then described. From the study, some common features of the TQM implementation, in the particular Thai context, are identified.

## **6.2 A theoretical framework for TQM implementation**

A drawback of much of the research in the literature cited in Chapter 2 is a lack of a theoretical framework of TQM implementation, to assist in comparing the various approaches studied. Some authors refer in general terms to Japanese and US/Western models of quality management, in the case of the latter often based on the framework provided by quality/business excellence awards. Award criteria, developed for the US Malcolm Baldrige Award, the European Quality Award, the Deming Prize in Japan and various national awards can be used to assess quality development in the context of their own principles and assessment frameworks, which have of course been subject to significant criticism.

There are many interpretations of TQM and numerous approaches by which it can be implemented, most of which aim to provide management with a best-practice route to success. The work of the 'quality gurus', including revered figures such as Deming, Juran, Crosby, etc. are sources of basic ideas

---

which a company or consultancy can follow or adapt for their own circumstances. Whichever basic approach is adopted, it has been widely acknowledged that TQM implementation requires a culture change in the organisation. The organisation needs to develop a suitable TQM implementation and performance improvement strategy, by adopting a change model which is culturally feasible (Kekale and Kekale, 1995). There is a substantial literature related to corporate culture and culture change for TQM, but the lack of an accepted theoretical framework has tended to encourage an indistinct and subjective debate about the nature and effectiveness of different approaches. For this study, the researcher considered that a framework for describing and classifying culture change for TQM would be useful. After a survey of the literature, the 'Sheffield TQM Model' appeared to provide a useful framework, based on fundamental culture change concepts which it was hoped would be robust to, and illuminate, international and cross-cultural comparisons.

**Table 6-1 Culture concepts in TQM (after Whittle et al, 1992)**

WHAT	HOW	Culture: Stable, unlearned, prescribed, tell and sell, designers v doers	Culture: Changing, focused, emerges, experienced, designers-doers
Culture: Independent, explains, homogeneous, managerial, traits/features, problem- solving		Visionary approach to Culture change	Learning approach to culture change
Culture: Dependent, needs explaining, local/political, meaning, tool- crafting		Planning approach to culture change	Transformational approach to culture change



---

Table 6-1 illustrates the key culture change concepts which underlie the Sheffield TQM model used in this study, which were developed by Whittle *et al* (1991, 1992) from the literature on culture change, management theory and inductive analysis of their company researches. Using these concepts, Whittle *et al* identified three generic paradigms (or 'mindsets') for total quality implementation and a further 'meta-paradigm' which informs and enables movement between the three. The characteristics of the four paradigms are as follows:

1. Visionary Total Quality (VTQ) is a strongly top-down management-led approach. Culture change is promoted by the strategic quality vision and ideology of top management which is communicated clearly and widely to all levels of employees. People are seen as programmable pawns. Providing management development and training for quality is one of the key issues in this model. The strategic quality programme is usually led and driven by the most senior executives.
2. Learning Total Quality (LTQ) emphasises a bottom-up style of organisational culture change. People are seen as willing participants. Employee empowerment and involvement is the key factor in TQM implementation. The natural work team is one of the important features emphasised in the LTQ organisation. The approach to TQM implementation is not explicitly strategic. Human resources or personnel specialists tend to drive the process.
3. Planning Total Quality (PTQ) is concerned with rational and systemic approaches to TQM implementation. An explicit programme is introduced

to provide systematic direction in TQM implementation. Project teamwork is one of the key activities in this model. Members of the project teams are trained to apply problem-solving tools and techniques in order to improve quality performance effectively. The PTQ approach tends to be introduced and developed by engineers or technologists, and the activity is mainly focused in manufacturing or production.

4. Transformational Total Quality (TTQ) is the meta-paradigm which allows an overview of the type and status of the organisational approach to TQM. Companies may reach a 'saturated' stage of diminishing returns using any of the paradigms above, when TQM progress starts to falter. From the viewpoint of the TTQ paradigm, TQM implementation is a cyclical process by which a company can choose the most suitable of the other models and move between them as necessary to rejuvenate the process and improve organisational performance. TTQ views people as purposive agents, and activities are typically speculative, involving re-framing, empowerment and paradigm shifts.

It should be emphasised that practical TQM implementations are unlikely to be based entirely in one paradigm. It might be expected, however, that they would show a tendency towards one or more of the implementation paradigms.

### **6.3 Data collection and analysis method**

This was empirical research carried out using a case study-based approach, aimed at three carefully selected companies operating in Thailand

---



---

which had been implementing TQM for a period of time. The companies were selected as representative types based on preliminary visits by the researcher. After contacting the selected companies and obtaining formal permissions, in-depth structured interviews of selected staff in different positions was used as a data collection method in order to understand the perspective of a variety of people in the organisations. The details of questions and how the questions were developed are described in appendix 6. The target personnel in each company were:

Top management

Production management

Quality management

Human Resources management

Marketing and supplier relations

Technical Personnel (R&D staff, Quality and Design engineers)

Supervisors

Shop floor operators

Shop floor inspectors.

The interviews were conducted in Thai, recorded and later transcribed for analysis. Apart from the in-depth interviews, documentation reviews and plant tours were also used to gain additional insights and more information about TQM implementation.

As rich and voluminous data was obtained from the interviews, a grounded theory approach was used together with qualitative content analysis

---

in the interview data analysis (Easterby-Smith, 1991 and Yin, 1994). The theoretical framework described in section 6.2 was used as the basis for analysis, with the intention of using the interview data to identify if the case-study companies had developed a TQM culture associated with one (or more) of the four implementation paradigms described above. The data collected from the interviews was analysed using a development of the phrase pattern-matching strategy for company. TQM attitude diagnosis proposed by Whittle *et al* (1993), which was used by these researchers in a relatively limited role as a tool for an intensive ‘assumptions surfacing’ seminar situation with senior management.

It was considered by the researcher that this method of analysis could be extended to staff at all levels to provide in-depth understanding of TQM implementation, and might also help identify differences in attitudes and assumptions between staff in different departments and at different levels.

The transcription of each interview was analysed according to the meaning of individual interviewee’s phrases which showed the match of the interviewee’s attitudes with one of the four TQ paradigms. The core phrases were those identified by Whittle *et al* (1993), but over a hundred and sixty extra phrases were identified, recorded and categorised (appendix 7). As examples, core phrases indicative of a VTQ paradigm would include; “senior management commitment” and “clear company mission”, while for PTQ phrases such as; “measure and monitor performance using SPC” and “use of problem solving tools” were signifiers. Phrases resembling “employee participation/ownership/empowerment” and “individual employee

---



---

development and education” would indicate a LTQ mindset. A TTQ paradigm would be represented by phrases such as; “open mindedness/readiness for change” and “strategic leadership/senior management reviews”

The result of the interview analysis showed that the three companies selected for investigation had each adopted a different approach to TQM implementation. Figure 6-1 summarises and compares the results from the analysis, indicating the emphasis of the interviewees based on significant phrases they used during the interviews. Different symbols are used depending to the position and responsibility of interviewees, in order to identify any differences in attitude between different positions (levels or specialisations). In the analysis process the meaning of specific phrases was carefully considered and classified. One ‘hit’ on the diagram represents one identified significant phrase used by an interviewee in each position, and was placed in the paradigm category of which it was most suggestive. Only one ‘hit’ from the same phrase is shown on the diagram even though it may have been mentioned several times during an interview. Group interviews were carried out with shop floor operators, inspectors and supervisors. The data collected from these group interviews were treated as for an individual interview.

Not surprisingly, the ‘hits’ from each organisation were spread across the VTQ, LTQ and PTQ paradigm categories. There were no phrases suggestive of a TTQ mindset from any interviewee. However, the diagram demonstrates that responses from different companies tended to cluster in a particular type of model, leading to the conclusion that the companies studied

---

---

had adopted an implementation approach which was biased in the direction of one of the paradigms described above.

#### **6.4 Analysis of the case studies**

The internal and external published documents of the case-study companies as well as the information transcribed from the in-depth interviews which had been transcribed were reviewed. The background of the companies and their TQM implementation policy is described in the following sections.

##### **6.4.1 The Siam Refractory Industry Co., Ltd.**

The Siam Refractory Industry Co., Ltd. (SRIC) is a wholly-owned subsidiary of the Siam Cement Group which is one of the biggest Thai-owned businesses in Thailand. SRIC produces refractory products to supply both domestic and export markets. Even though SRIC was registered as a company only in 1993, it had been operating since 1953 to serve internal demand in the Siam Cement Group. With the increasing demand from inside and outside the company, production capacity was expanded from 12,000 ton/year in 1953 to 24,000 ton/year in 1961 and continued growing to 150,000 ton/year in 1997. About 500 people are employed in its facility located in Saraburi province.

In the long period of operation before the establishment of SRIC, many quality activities such as QCCs, 5-S practice and a suggestion system had been introduced by Siam Cement Group headquarters. The quality programme in the Siam Cement Group is called 'Total Quality Commitment (TQC)' which means that every employee at all levels is expected to commit themselves to

---



---

continuous improvement to satisfy their customers. Siam Cement began their TQC journey in 1993 by training executive management of their subsidiary companies and setting up four pilot companies including SRIC, which as a first stage was certified to ISO 9002 in 1994. A TQC promotion manager was appointed and trained in order to promote and implement the TQC programme. Japanese consultants have been used to guide the company to implement TQC effectively in terms of strategy and a medium-term plan as well as with the use of problem-solving tools and techniques.

All managers are expected to be leaders in using quality tools and techniques. A management training programme was started in the early stages to develop management capability and understanding of 'TQC'. Top management played very important roles in the TQC implementation. Short-term plans were developed in every department to meet the objectives stated in so-called 'MD policy'. A company meeting chaired by the Managing Director was held every month to follow up and review TQC implementation performance. 'MD policy' was clearly communicated throughout the company. Past performance analysis was carried out in order to consolidate the knowledge and understanding gained from the past and to establish a suitable new or revised plan. Problem solving tools and techniques were used to improve productivity, efficiency and effectiveness, mainly in the manufacturing areas, led by an engineer or manager.

The interview phrase analysis showed that the company tended to be primarily a VTQ organisation led by a charismatic figure (the Managing Director). However a significant number of phrases indicative of both PTQ

---

---

and LTQ paradigms were also recorded from interviewees in many areas of the company, showing appreciation of the importance of technique-led and human factors-led approaches.

The approach to TQC implementation was perceived internally as changing management behaviour from 'KKD' to 'management by fact'. KKD is a Japanese acronym referring to Keiken (experience), Kan (intuition) and Dokyo (gut) and means that experience and intuition are used to solve problems while for management by fact, management must investigate objectively and gather data before they plan and implement improvement projects or attempt to solve chronic problems. The Deming PDCA cycle is the basic approach used, guided by the consultants who visit the factory regularly to advise and comment on strategic planning and problem solving tools and techniques. In spite of the fact that bottom-up activities such as QCCs, a suggestion system and 5-S practice were maintained continuously, it was apparent that charismatic leadership was the most important driver for the quality journey at SRIC.

#### **6.4.2 Toshiba Consumer Products (Thailand) Co., Ltd.**

Toshiba Consumer Products (Thailand) Co., Ltd. (TPT) is located in Patumthani province near Bangkok. It is a subsidiary of the Japanese Toshiba Corporation and manufactures refrigerators, air-conditioners and washing machines. Over ninety per cent of its production is exported to countries all over the world, including Japan. Employing about 2,800 people in Thailand, TPT has an annual production capacity of approximately 400,000



---

refrigerators, 600,000 air-conditioner sets and 600,000 washing machines per year.

It is very difficult to identify a starting point for quality at Toshiba. It is a company which, in a Japanese style, has always been firmly focused on quality, but has never had an explicit TQM implementation programme, and does not use 'Total Quality' terminology to describe its methods. Quality has always been central to top management strategy since the Thai operation started in 1990. TPT was certified to the ISO 9002 quality system standard in 1995. Quality improvement (QI) activities which involve all employees (especially shop floor operators) have been continuously developed, particularly QCCs, abnormal situation reports, the suggestion system, 5-S practice and safety. A notable feature of the plant is the evident enthusiasm and commitment with which shop-floor workers apply themselves to QI activities in their QCCs whenever breaks in production allow. Also related to quality are the current development efforts towards Total Productivity (TP), TPM and ISO 14000 Environmental Management, which were started in early 1996. Employee participation, empowerment and team work are critical factors in the successful management of these activities. Training is at the heart of quality activities, and all new employees are trained in order to understand 5-S practice, safety, QCCs, 7 quality tools, etc. The motivation to employees to participate in these activities involves reward and recognition as well as performance appraisal. The best QCCs have the opportunity to compete in regional presentation events and if successful in those they can go and compete against the top Toshiba QCCs in Japan.

---

The interview analysis showed that Toshiba responses favour the LTQ paradigm. As can be seen from Figure 6-1, the phrases recorded were concentrated overwhelmingly in this sector of the diagram. The importance placed on the natural working team was clearly shown in the responses. Employee development was a key focus to educate and foster good attitudes towards quality among employees. The company has a lifetime employment strategy, and although in Thailand a high labour turnover rate is an obstacle, all employees are educated and developed in order to improve their working capability and creativity. Most of the programmes launched were aimed primarily at shop floor workers. Five-S practice, safety, QCCs, suggestion systems, abnormal situation reports, TP and TPM were high-profile QI activities in which shop floor employees were the main participants. Morning meetings were a regular feature of the working day for leaders or supervisors to involve and provide important information to workers.

#### **6.4.3 Read-Rite (Thailand) Co., Ltd.**

Read-Rite (Thailand) Co., Ltd. (RRT) is one of the US Read-Rite Corporation's manufacturing plants. It produces personal computer disk-drive components such as sliders; Head Gimbal Assemblies (HGAs) and Head Stack Assemblies (HSAs). It started business in 1991 and has expanded rapidly to become a large operation employing approximately 12,000 people at the plant which is located in Ayuthaya province. A Just-In-Time approach and some world-class IT applications support an effective manufacturing environment.



---

In recognition of the increasing competitiveness of world business, Read-Rite Corporation has embraced a TQM philosophy entitled 'TQM: The Read-Rite Way' which is defined as: "building and evolving a stakeholder (stakeholders are customers, employees, shareholders, and suppliers) - focused management system and supporting culture that has as its driving force, meeting customer needs the first time and every time". RRT commenced TQM implementation in late 1994, with a three-year plan aimed at building up the infrastructure and moving the organisation towards a TQM culture. RRT's TQM implementation plan was structured by, and the responsibility of, an executive steering committee involving top management. The plan involved the deployment of systems for TQM planning, communication and promotion, training and development, teams and team support, rewards, recognition and employee involvement, measurement and benchmarking, voices of the customer and the supplier, together with ISO 9000/14000 quality and environmental systems.

The first year was the 'Introduction' phase, which started with setting up the systems and providing knowledge and concepts of TQM. Awareness training was provided for all employees by the in-house training centre. Problem-solving tools and techniques training was cascaded from top management to supervisor level. Company-wide communication and promotion of TQM activities was conducted using posters, newsletters, videos, promotion boards and the company computer network. The second year was the 'Development' phase, where QI teams led by managers who had been trained to use problem-solving tools and techniques applied their knowledge to

---

improve working processes. QI project teams were established by registering with the TQM office. Each team had a senior manager as a sponsor to support their activity. The improvement theme usually involved a 'breakthrough' project to improve efficiency, productivity or provide a cost-saving. Problem solving tools and techniques were applied for particular project as appropriate. After evaluation by a committee, the best project teams were recognised and rewarded at the 'Team day' organised every six months. 'Team day' was an important event in the TQM programme to show management commitment and recognise the efforts of the project teams.

RRT was certified against the ISO 9002 quality system standard in December 1995 and six months later they obtained ISO 14000 certification, in accordance with their TQM plan. The third year was the 'Integration' phase, in which it was expected that 'TQM behaviour: Read-Rite way' would become RRT's everyday way of working. The study was carried out towards the end of this final period.

The interview results (Figure 6-1) showed that RRT had primarily favoured the PTQ paradigm to provide a systematic approach to TQM implementation for their large facility. A significant number of responses, particularly from management interviewees also indicated that the LTQ paradigm was considered of importance, however even though key objectives of the TQM programme were focused on changing behaviour, the numerous shop floor operators had only been involved in the TQM programme in terms of awareness training and TQM promotion. The participation of operators in quality project teams was still at a low level.

---



The US background of the company was clearly evident in their approach. At an initial stage, the Malcolm Baldrige Award criteria were used to evaluate the status of quality management in the company. A major planning operation then followed, which was implemented efficiently. A considerable training effort was aimed at providing technical and management staff with sophisticated problem-solving techniques. Read-Rite has developed a highly-sophisticated plant-wide on-line computer network to assist communication, provide a more efficient working environment and to help train their employees. The computer network was used as one of the tools to promote the TQM programme throughout the company. Employees working in operation or inspection areas could review quality data, work instructions, procedures and specifications using their desk computer or at shop floor 'computer kiosks'.

As described above, Read-Rite had established a 3-year plan for its TQM implementation. However in conversation with top management, TQM was conceded to be a never-ending journey, and the company believed it might need to review and evaluate the programme to find out the next endeavour in order to continuously maintain the TQM process.





### **6.5 Common features of the TQM implementations**

The results of this study also showed that all three investigated companies had common characteristics in their TQM implementations. The following features were found in all the companies:

1. **Management commitment and leadership.** It is acknowledged that TQM implementation cannot be successful without top management commitment and support. In all these three companies, it was obvious that quality activities were fully supported and led by top management.
  2. **Effective communication within the organisation.** Good and effective communication between management and staff is considered vital for TQM implementation. Although the three companies used different approaches and media to communicate with employees, all of them had effective ways to disseminate TQM information.
  3. **Problem solving tools and techniques.** These tools and techniques are known to be effective methods to help employees improve their work and to assist motivation and involvement. TQM companies have to facilitate and empower their employees so that they can apply those tools effectively. All three companies used these methods extensively.
  4. **Group activity.** “Working as a team” is at the heart of TQM. All the studied companies emphasised the important of group activity in their TQM programmes.
  5. **Employee training and development.** Human resource development is considered to be a key success factor in TQM implementation. Effective training programmes were a feature of all three companies studied.
-

One of the questions asked during each interview concerned the aptitude and attitude of the Thai workforce for TQM implementation. In each case the responses confirmed that the workforce was receptive and supportive of the organisation. In one company studied there was some uncertainty among management about the potential of the less well-educated shop floor operatives for using problem solving tools and techniques. However at Toshiba, it was evident that with suitable training and supportive QCC all workers could become involved effectively.

## **6.6 Conclusions**

The analysis of these case studies indicates that the companies studied have each adopted different, but successful, approaches to TQM implementation. It should again be emphasised that the case-study companies were pre-selected to provide representative types. The different approaches to TQM implementation identified in the Thai, Japanese, and American-owned companies studied were illuminating yet not unexpected. For example the PTQ approach found at Read-Rite was considered by the researcher to be typical of what might be expected of a large subsidiary of a US corporation, employing a competitive strategy based on moving manufacturing to a developing country and applying strong quality management disciplines. The 'bottom-up' LTQ model employed at Toshiba was considered to be representative of good Japanese quality management practice. At Siam Refractory Industry, Japanese ideas were also important, but modified in this company by the influence of a charismatic leader towards the VTQ paradigm.

---



The presence of such a strong figure might be expected in one of the first Thai-owned companies to have made the transition to TQM.

Despite the differences, important common characteristics of successful TQM implementations were found in all the three companies. These were considered to be management commitment and leadership; good communications; effective use of problem solving tools and techniques; group activity, employee training and development.

The 'Sheffield TQM model' and the analysis methodology employed for this study has providing a valuable framework against which different approaches to TQM implementation can be assessed. The qualitative content analysis techniques used to classify interview phrases against TQM mindsets proved to be time-consuming but allowed a considerable degree of objectivity in the assessment of a rich and voluminous body of data. In the view of the researcher this approach has good potential for the analysis of quality management approaches. Evidence of the 'overview' Transformational Total Quality (TTQ) approach was not observed in the current study, but the authors believe it is useful for senior management responsible for a company's TQM programme to acquire a TTQ perspective and appreciate where their organisation's current approach lies in the spectrum of possible approaches.

## **7. The Thai foundation quality system standard (TFQSS)**

### **7.1 Introduction**

In the developed economies where ISO 9000 standards are well established, there has been considerable discussion about the implications of the standards for smaller companies, with criticisms made of their complexity, costs of implementation and of quality system maintenance, as described in Chapter 2. Despite these criticisms, the tendency, is if anything, to add more requirements as the standard evolves. Perhaps surprisingly, there is currently little international interest evident, in the development of a more basic 'foundation level' quality systems standard, targeted at small and medium enterprises (SMEs). The standard which might perhaps have been expected to fulfil that role, ISO 9003, is targeted instead at the relatively rare scenario of a company requiring only final inspection and test, and is hence relatively little used.

This chapter presents the research which aimed to develop and introduce a 'foundation level' quality systems standard, called "Thai Foundation Quality System Standard (TFQSS)" to Thai SMEs. The foundation level quality systems standard is reviewed. Then the TFQSS development project and establishment of its requirements are described. The

---



first draft of the TFQSS has been successfully implemented by five Thai SMEs.

## **7.2 The foundation level quality systems standard**

The Q-Base (Telarc,1996) approach developed by Telarc, a New Zealand accreditation and certification body, was the only example of an established entry-level quality systems standard available to the researcher at the start of the project. ISO 9000 series standards are well established in larger New Zealand businesses, but the country has many SMEs which wish to set up quality management programmes, but which do not yet aspire to an ISO 9000 series standard. This standard, which is derived directly from ISO 9000 series is called the 'Q-Base Code' and has seven sections as follows:-

1. Management of the quality system
2. Control of critical; documents and records
3. Customer needs
4. Purchasing
5. Training and work instructions
6. Inspection and control of substandard work
7. Quality improvements

The standard is part of an integrated system of registration and certification for smaller companies which is operated and publicised through regional business development boards. It is specifically derived from ISO 9001/2 in order to allow an easy transition to these standards.

---

The Q-Mark standard which was launched by the Irish Quality Association in the 1980s was another example of an entry-level quality system standard. According to Wallace and Murphy (1993), Q-Mark was successful not only as a stepping stone to the ISO 9000 standards but also as a stand-alone quality 'hallmark' for non-exporting companies. Q-Mark was however completely revised in 1998 to be an entry-level business excellence approach based on a cut down Irish Business Excellence Model, which is itself based on the European Quality Award framework

### **7.3 *The TFQSS development project***

Planning for the TFQSS development project took place at NSTDA in Thailand during 1997. The project objective was:

**'To develop the Thai Foundation Quality System Standard (TFQSS) an 'intermediate' quality management system standard for small Thai businesses which will assist them to increase awareness of quality and develop towards internationally recognised standards of quality management.'**

The development phase of the project commenced in October 1997 with the selection and recruitment of five representative small and medium Thai businesses as collaborators in the development of the TFQSS. Co-ordination of the project was undertaken primarily by a full-time project facilitator, who worked closely with the companies using the draft TFQSS prepared by the researcher with the aid of an academic consultant employed by NSTDA.



The standard was initially prepared in English, then translated into Thai. Before use with the collaborating companies the first draft was distributed to ten leading Thai quality management experts and consultants selected from business and academia, with a request for comment and advice on improvements. Lengthy and useful comments were received from most of these experts, many of whom were clearly most familiar with an ISO 9000 series approach to quality systems implementation, and naturally tended to propose additional elements based on that background. The commentators also made a number of suggestions to improve the translation of the standard into Thai. A summary of their responses is provided in appendix 9.

Many modifications were made to the draft TFQSS as a result of these comments, but the temptation to add many of the elements proposed by the various commentators was resisted, as taken together these would have transformed the TFQSS into a standard similar in scope to ISO 9002.

The implementation of the draft standard was monitored and the standard revised as necessary to meet the real needs of Thai SMEs as exemplified by the collaborating companies. The introduction of a quality system is widely believed to be more difficult, for many small businesses, because management time and skill is a scarce resource. The project therefore aimed to provide continuing support to the participating companies, to identify any such problems and to assist with implementation and initial application of the standard. Issues surrounding success and failure were assessed and a report prepared. The final period of the project would also allow the refinement of the TFQSS to meet any emergent requirements.

---

#### **7.4 Developing the TFQSS requirements**

It was considered that the development of the TFQSS might be approached in two ways:- either by 'cutting down' an existing ISO 9000 series standard (as with the New Zealand Q-base Code), or starting afresh. The latter approach was adopted, largely because of the difficulty in deciding which elements of an existing standard should be omitted. The drafting process therefore commenced with a blank sheet of paper. The researcher, assisted by the project academic consultant, who were both familiar with the ISO 9000 series standards, attempted to start from the first principles of quality management. The TFQSS was conceived as a standard operating at a quality control rather than a quality management level. The main focus throughout was on simplicity rather than comprehensive coverage.

The author considered that starting with the identification of a quality policy is the best way to begin a quality journey for a company that has no knowledge at all about quality management. Planning for quality and the implementation of a quality control system were next identified as the basic elements that are essential and cannot be absent in a quality system. Not only internal but also external factors (such as suppliers) can affect the quality of products and services. Therefore, purchasing and suppliers were included in the scope of the standard.

Some expert commentators suggested that the standard should include a clause requiring a process of internal quality audit similar to that required in ISO 9001 (clause 4.17)'. After careful consideration, the researcher excluded

---



this requirement, because it was considered that this would be difficult and off-putting for the companies at which the TFQSS was targeted, because of the substantial additional documentation requirements and the need for staff time, expertise and training. It should be remembered that most companies involved (details available in Section 7.5) had no formal quality control system at all, no written specifications or work instruction, etc. Only one company had already established any type of formal quality system (GMP).

The TFQSS also does not require a contract review process or product identification and traceability which are also key elements of the ISO 9000 series standards (clauses 4.3 and 4.8 respectively). The author thought of these clauses as coming primarily from the background of the ISO 9000 series standards in standards developed for aerospace and military requirements. The more basic TFQSS expects a company to focus primarily on the quality control loop - producing products and services that conform to specifications acceptable to the customer or the market (and of course saleable). Contract review in either ISO 9000 or Q-Base Code requires a company to review the 'customer order' or 'contract' which is not an objective of this standard. Product identification and traceability is implicitly covered if it is required by regulations or statute. The TFQSS standard is expected to be an achievable and easy-to-implement standard that encourages Thai SMEs to start a quality programme.

Hence the initial draft of the TFQSS included only the following basic elements:-

---

1. Quality Policy and Objectives
2. Planning for Quality
  - 2.1 Quality Specifications
  - 2.2 Process and Inspection Planning
  - 2.3 Staff and Training
  - 2.4 Document, Data and Record Control
  - 2.5 Product and Material Care
3. Quality Control System
  - 3.1 Checking to Quality Specifications
  - 3.2 Control of Quality Rejects
  - 3.3 Process Control
  - 3.4 Corrective Action
4. Purchasing and Suppliers

The standard was written in simple terminology. The requirements were clearly identified and separate guidelines were provided for particular requirements in order to help the user in the implementation process. The following are English version examples of a typical requirement and related guidance:

***Requirement***

***2.2 Process and inspection planning***

- *All processes to produce or deliver the product and/or service must be identified and documented in the form of work instructions and distributed to ensure that the correct methods are known to all staff.*



- *Test and inspection plans must be established and distributed to ensure that the product and/or service conforms to specification.*

### **Guidance**

**Process and inspection planning.** The work instructions consist of appropriate descriptions of the sequence of operations which produce or deliver the product and/or service to the customer. The work instructions may take many forms such as flowcharts, pictures, written descriptions, etc. Operations may require the use of equipment or facilities, which should be defined. For example, all production machine settings for each different product must be written down and made available to the staff responsible for production.

Where test and inspection operations are necessary to check that quality specifications are met at any stage of the process, these should be included in the inspection plan. The test and inspection task should be planned and performed to identify any non-conformance to the product and/or service specifications at the earliest possible stage of the process. This will avoid waste.

The details of all requirements and guidance are in appendix 10.

Having drafted the elements of the standard, a comparison was made with ISO 9001. Table 7-1 illustrates the results.

**Table 7-1 TFQSS elements compared with ISO 9000**

<b>TFQSS Element</b>	<b>ISO 9001 Element</b>
1. Quality Policy and Objectives	4.1.1 Quality policy
2. Planning for Quality	
2.1 Quality specifications	4.2.3 Quality planning, 4.4.4 Design input, 4.4.5 Design output
2.2 Process and inspection planning	4.9 Process control, 4.2.3 Quality planning
2.3 Staff and training	4.1.2.1 Responsibility and authority, 4.1.2.2 Management representative, 4.18 Training
2.4 Document data and record control	4.5 Document and data control, 4.16 Control of quality records
2.5 Product and Material Care	4.15 Handling, storage, packaging, preservation and delivery
3. Quality Control System	
3.1 Checking to Quality Specifications	4.10 Inspection and testing, 4.11 Control of inspection, measuring and test equipment 4.12 Inspection and test status
3.2 Control of Quality Rejects	4.13 Control of nonconforming product
3.3 Process Control	4.9 Process control
3.4 Corrective Action	4.14 Corrective and preventative action
4. Purchasing and Suppliers	4.6 Purchasing



Table 7-2 shows a comparison between the TFQSS and the New Zealand Q-Base code. Both are compared with ISO 9001/2 systems elements. It can be seen that the Q-Base code is more comprehensive than the TFQSS in terms of ISO 9000 series coverage. The only area where the TFQSS requires coverage and Q-Base code does not is for design control, where the TFQSS specifies a design process if required, to properly establish and record Product and Service Quality Specifications and to comply with any relevant statutory requirements or codes of practice.

The comparison between the elements required in these basic quality management systems and those of ISO 9001 clearly highlighted the complexity of the latter, and its ancestry among the military standards designed to provide a foundation for quality management in complex design and manufacturing scenarios.

### **7.5 *Implementing the TFQSS in the collaborating companies***

Five representative Thai SMEs were selected from the companies which applied to participate in the project. The criteria of selection were:

1. at least 51% Thai owned,
2. capital investment not over 100 million Baht (MB); and
3. commitment of top management to the project.

**Table 7-2 Coverage of Q-Base Code and TFQSS compared with ISO 9000**

ISO 90001/2 Clause	Q-Base				TFQSS		
	Not Covered	Partial	Full		Not covered	Partial	Full
4.1 Management Responsibility		■				■	
4.2 Quality System		■				■	
4.3 Contract Review		■			■		
4.4. Design Control (ISO 9001 only)	■					■	
4.5 Document and data control		■				■	
4.6 Purchasing		■				■	
4.7 Control of customer supplied product	■				■		
4.8 Product identification and traceability		■			■		
4.9 Process Control		■				■	
4.10 Inspection and Testing		■				■	
4.11 Control of inspection, measuring and test equipment		■				■	
4.12 Inspection and test status		■				■	
4.13 Control of nonconforming product		■				■	
4.14 Corrective and preventative action		■				■	
4.15 Handling, storage, packaging, preservation and delivery		■				■	
4.16 Control of Quality Records		■				■	
4.17 Internal Quality Audits	■				■		
4.18 Training			■			■	
4.19 Servicing	■				■		
4.20 Statistical techniques	■				■		



The collaborating companies typically saw the TFQSS as the first step for them to progress towards an ISO 9000 series standard, but they also expected it to help them be competitive and improve their effectiveness and efficiency of their work. For confidentiality, these companies were identified as companies A, B, C, D and E. Table 7-3 gives details of the selected companies

**Table 7-3 The collaborating companies**

<b>Company</b>	<b>Industry type</b>	<b>% export production</b>	<b>Number of Employees</b>	<b>Capital Investment (MB)</b>
A	Clothing (shirts)	100	180	4
B	Pharmaceutical products	0	64	14
C	Industrial paints and inks	5	150	7.5
D	Tubular cable support conduit	50	150	100
E	Stainless steel fasteners	80	30	20

The project facilitator together with one of the NSTDA technical staff conducted preliminary fact-finding assessments in each company during October 1997. They interviewed top management and departmental managers to obtain background information about the company, its manufacturing and business processes, the current quality system and any significant quality-related problems.

In this preliminary assessment, most of the companies were found to have major deficiencies in quality management. An outline of the five collaborating companies is given below.

**Company A.** Company A employed operatives who were mainly of a low educational standard. The garment making process is complex and relies heavily on staff experience and manual dexterity. Management expertise was limited largely to the Managing Director. Communication and policy deployment including implementation of procedures were anticipated to be challenging for this company.

**Company B.** This company was found to be well-organised and had an established GMP (Good Manufacturing Practice) quality system as a condition of its accreditation for pharmaceutical manufacture by the Thai FDA. Here a considerable portion of the TFQSS requirement was already in place, and top management was committed to the project. This company was expected to achieve the standard without great difficulty.

**Company C.** Company C was a well-run small company, with adequate management systems and a degree of formal quality control. This company had ambitions towards ISO 9000, and saw the TFQSS as a start in that direction. Management appeared enthusiastic about the project.



*Company D.* Company D manufactured steel conduit using a sequence of cold forming, welding and machining operations, followed by hot-dip galvanising. The company had informal or non-existent quality management methods, and a number of difficulties with housekeeping, operations management and process safety. Company D had initially intended to implement ISO 9002 but encountered problems in hiring a consultant, and was considered the most challenging company involved in the project.

*Company E.* Company E manufactured standard bolts in stainless steel, using cold-forming and thread rolling methods. This company exported a large proportion of its output, but had limited engineering expertise and largely informal quality management methods, although having previously been in Japanese ownership there was some awareness of quality issues.

It can be seen that the companies selected represented a spread of maturity in quality terms, ranging from a total lack of formal quality systems to substantially complete quality control with some elements of quality management systems.

The project facilitator visited each of the collaborating companies regularly, at least once every two weeks, encouraging and assisting them to implement the standard. In February 1998 the researcher accompanied the project facilitator on visits to the companies. In each case senior managers expressed enthusiasm for the project and satisfaction with the work of the

---

---

project facilitator. Initial progress was however patchy, and significant difficulties were found in areas associated with the quality management system, typically a lack of formal production planning. It was notable that some of the companies had major problems with basic housekeeping and cleanliness. Effective provision for the health and safety of employees was also an area which required attention in some companies. Management expertise was typically limited to a small number of individuals, and in one case a company with more than 180 employees was managed almost entirely by the owner, who was nevertheless very active in developing product specifications and information systems to meet the TFQSS requirements

As the deadline for the TFQSS assessment drew nearer, however, progress in all companies improved greatly, with the encouragement and help of the project facilitator. A pre-assessment was arranged, for which the facilitator accompanied by three other NSTDA audit staff made comprehensive checks of procedures and documentation. At this stage management and staff in some of the collaborating companies were working long hours to ensure success in the assessment, determined to avoid the loss of face which would result from failure.

The final assessment audit was carried out by the researcher in July 1998 and the results were most encouraging. Although no company was completely free of non-compliance with the standard, these were relatively few in number and readily amended. Comprehensive reports detailing all problems were immediately prepared and sent to the companies. A final visit to all the companies by the researcher, accompanied by the facilitator, took

---



place shortly after the assessment audit, to check whether the non-compliance had been addressed. All companies had done enough to achieve the requirements of the standard. Table 7-4 summarises company position at October 1997 | February 1998 | July 1998 (assessment audit), using the following scale.

0. No systematic attention;
1. Initial efforts to prepare a procedure;
2. Draft/hand written/incomplete documentation;
3. Documented but un-implemented, or operational informal procedure without documentation;
4. Documented but not fully implemented, or an effective system with partial documentation;
5. Fully documented and implemented.

It was notable towards the end of the project that company managers had gained greatly in confidence. Where initially many had been reticent and even embarrassed when discussing their company systems, they now confidently presented revised quality documentation, new record forms and management information summaries to progress meetings. Shop floor workers were also keen to display their calibrated measuring instruments and work instructions. In some companies the effects of the introduction of the

---

TFQSS had also had a noticeable beneficial impact on areas such as production planning, housekeeping and health and safety.

**Table 7-4 Summary of companies position**

<b>TFQSS Element</b>	<b>A</b>	<b>B</b>	<b>C</b>	<b>D</b>	<b>E</b>
1. Quality Policy and Objectives	0   5   5	0   3   5	0   3   5	3   4   5	0   5   5
2.1 Quality Specification	1   5   5	3   3   5	1   3   5	1   3   4	1   3   5
2.2 Process and Inspection Planning	2   2   5	2   2   5	0   0   5	0   0   5	1   3   5
2.3 Staff and Training	0   3   5	3   4   5	3   4   5	0   0   5	0   2   5
2.4 Document, Data and Records control	0   4   5	3   4   5	1   2   5	0   3   4	0   4   4
2.5 Product and Material Care	1   3   5	4   5   5	0   4   5	1   2   5	0   0   4
3.1 Checking to Quality Specifications	0   3   4	4   4   5	2   4   4	0   3   4	0   3   4
3.2 Control of Quality Rejects	0   0   5	4   4   5	2   3   4	0   1   5	1   4   5
3.3 Process control	0   3   4	4   4   5	2   4   5	1   2   5	0   3   5
3.4 Corrective action	0   0   4	0   0   5	0   0   4	0   0   5	0   0   4
4. Purchasing and Suppliers	0   3   4	0   2   5	0   3   5	0   2   4	0   0   4



## **7.6 Conclusions**

This project demonstrated that the TFQSS is suitable for the purpose of providing an intermediate quality systems standard for Thai SMEs. The standard developed for this project has been successfully implemented by all the five collaborating companies. The standard was seen by most collaborating companies as a significant challenge, and yet was achieved by all in a period of 9 months, which is about one half of the average implementation period for ISO 9002 (TPI, 1997). Most of the companies, after having achieved TFQSS now believe themselves to be capable of further progress in quality management, and were planning to move towards either ISO 9000 series standards or TQM. In the course of implementing the standard, many of the companies developed formal administrative systems for the first time, having previously used only informal management systems.

The methodology employed by the TFQSS project was also successful. The choice of companies was representative of typical Thai SMEs, and covered a number of significant industry types. The use of a project facilitator to work in a consultancy role with companies has also proved valuable. A typical comment from senior company managers was that they needed a consultant or facilitator to help them understand the requirements of the standard and take the first steps towards meeting them. The pre-assessment together with external audit approach was also successful as it had a strong motivating effect on the companies to achieve the TFQSS requirements.

---

From the results of this research project it is clear that the TFQSS has the potential to make a useful contribution to the Thai economy by improving the quality performance and awareness of SMEs towards international standards of quality management. When the current economic difficulties ease, competition in both domestic and international markets will increasingly be based on quality as well as cost. To prepare themselves for that time, many smaller businesses can benefit from the adoption of a simple, entry-level quality standard. The TFQSS has demonstrated its ability to fulfil that requirement, either as an end-point in itself or as a useful step towards an ISO 9000 series standard.



## **8. Discussion and conclusion**

### **8.1 Introduction**

This final chapter summarises the findings and conclusions of the four linked research projects described in the earlier chapters. It aims to form responses to the research objectives and research questions posed at the beginning of the thesis. As an aid to the reader, the research objectives and questions as well as the major methods used in the study are briefly reviewed below.

The objectives of this study were twofold. The main aim was to examine the development and implementation of quality management in Thailand in general, and to investigate the ISO 9000 and TQM implementation process on Thai industry in particular, in order to draw up a picture of quality management for Thai industry. The second aim was to compare the Thai perspective on quality management with the situation in other developing countries, especially those in South and East Asian region.

The research questions may be summarised as follows:

1. How is quality management developing in Thailand?
-

2. What are the current position and trends of quality management in Thai industry?
3. How are the ISO 9000 standards being implemented in Thai organisations and what is the impact of implementation?
4. How is TQM adopted in companies located in Thailand?
5. Can a basic quality system be developed, suitable for Thai SMEs which are not yet ready for ISO 9000?
6. What is the current situation of quality management in other developing countries, especially those in South and East Asian region?

The research methodology employed in this study was based on a “theory-building” approach in order to explain phenomena and add to existing theory or knowledge with new findings based on empirical data collected. It comprised four linked research projects. The first was a survey which was conducted to identify the current position and trends of quality management in Thai industry. After the survey study, the researcher conducted a further three multiple case-study research projects which were the ISO 9000 study; the TQM study; and the TFQSS study. The details of the results and conclusions drawn from the four studies are provided in Chapter 4, 5, 6 and 7.

In the following section, a proposed framework provides an overview picture of quality management as developed in Thailand and responds to the above questions 1, 2 and 4. The development and implementation of ISO 9000 quality systems standards is covered separately in section 8.4 which provides answer for question 3. A proposal for an intermediate or basic

---



quality system standard to be used in Thai industry (question 5) is suggested for the future.

Although the research was not focussed primarily on policy issues, the findings of the research raise some government industrial policy implications for Thailand. These are discussed in section 8.6. The comparison between quality management in Thailand and other countries (question 6) is explored in section 8.7. Limitations of the research and recommended further research are suggested in section 8.8 and 8.9 respectively. Finally the thesis concludes with a section summarising the contribution to knowledge.

## **8.2 *Quality management in Thailand - A TQM framework***

The development of Thai quality management started a century ago but its implementation was slow. It was only in 1986 that the concept of TQC, emphasising QCCs, was introduced and prospered in the country. The second wave of quality management advancement was when ISO 9000 was adopted as a Thai national standard and became well known among Thai industrialists.

In fact quality management concepts, among other ideas, can be considered as a kind of technology which has been transferred from developed countries. The major sources of knowledge are Japan and USA via joint partnership and foreign-owned companies. The concepts which have been transferred to Thailand are QC, QA, 5-S practice, QCCs or teamwork, the ISO 9000 series of quality systems standards, QS 9000 for the automobile industry,

---

TPM, BPR and TQM including the concept of the Thai National Quality Award (NQA) which is derived from the US MBNQA.

During the lengthy period of this study, the researcher has gradually developed her understanding of and insight into the development and implementation of quality management particularly in Thailand. This induced her to develop a TQM framework to help provide a clearer understanding of the overall picture of quality management in Thailand. This model might be useful not only to Thai organisations but perhaps also interesting to other firms or consultants etc. Figure 8-1 illustrates the TQM framework which was derived from the results of the four linked studies and from the literature. It combines three dimensions of quality management in a Thai organisation, together with three important aspects, five stages of development and four implementation paradigms, against which a particular organisation's status can be examined, or against which a particular aspect or weakness can be highlighted and improved.

The three aspects of quality management, which have been widely accepted by many authors (for example Oakland (1993) and Kehoe (1996a)) to be important for quality management, are identified as the first dimension of the TQM framework. Crosby's idea of 'quality management maturity grid' (Crosby, 1980) as well as a clear picture of the unequal status of quality development in the various companies investigated in the ISO 9000, TQM and TFQSS studies, leads to the second dimension which covers five stages of quality development ('unaware' through 'sustaining'). The 'Sheffield TQM Model' that was used as the theoretical framework in the TQM study provides

---



the perspective on TQM implementation paradigms, which effects particularly the higher stages of quality development. Hence, paradigm shift for TQM implementation was considered to be the third dimension of the TQM framework. It is obvious that the higher an organisation develops its quality management approach, the more effectively they can integrate the three aspects of quality management. This is indicated in the diagram by its converging or triangle shape. The 'tepee' shape of the diagram comes from these ideas, based on the TQM study. Finally, all the studies as well as the author's business and quality experience in Thailand have helped to identify specific quality approaches in each aspect of systems, people and techniques which characterise each development stage. The description of three dimensions of TQM framework follows.

**Figure 8-1 Quality management concepts in Thailand - a TQM framework**

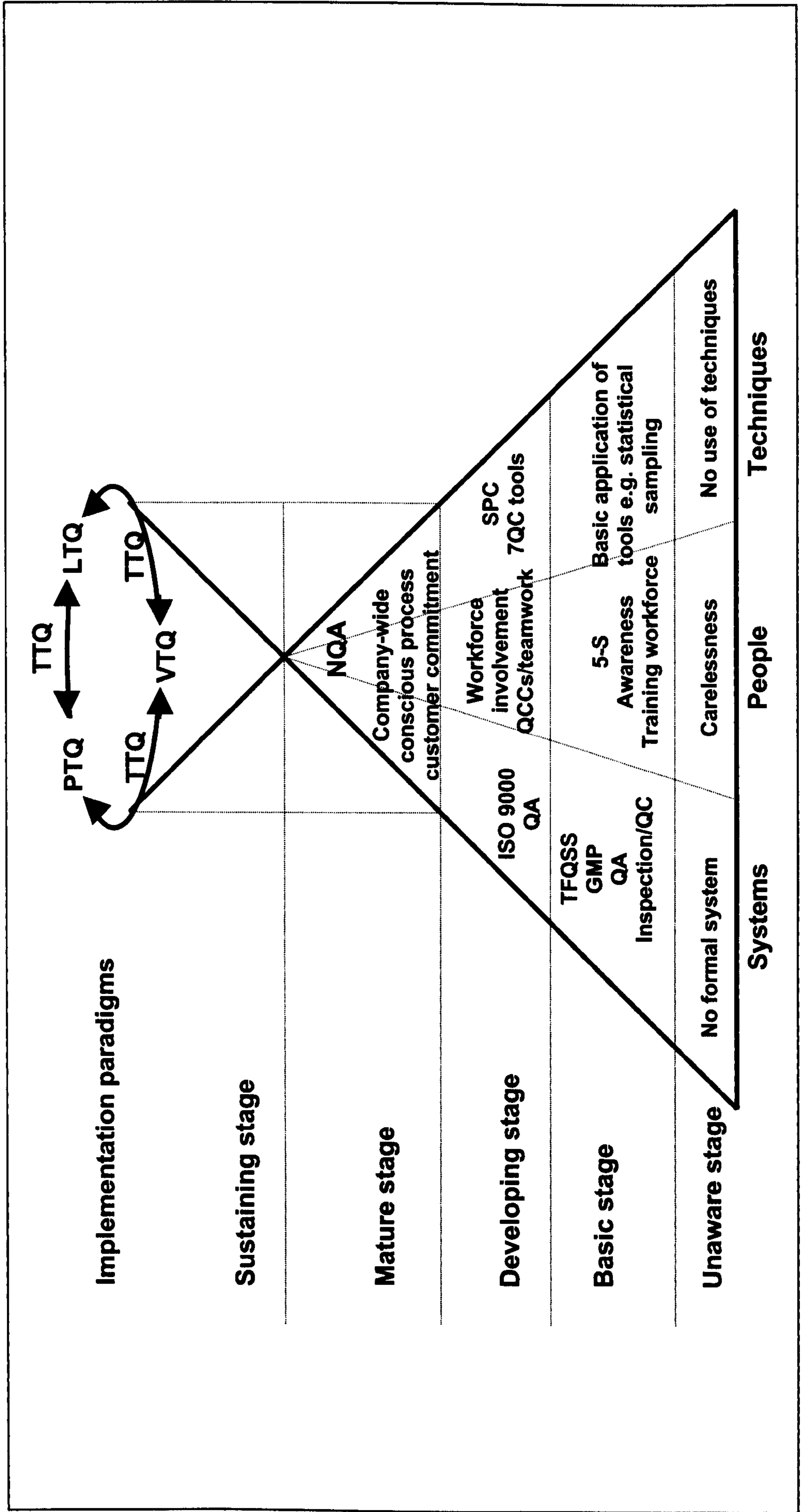



### **8.2.1 Aspects of quality management**

There are three aspects, in the first dimension, which are crucial for quality management. These are systems; people; and techniques. This basis is found in various similar forms in the literature (see for example Kehoe, 1996a).

#### **8.2.1.1 Systems**

Systems provide the infrastructure for an organisation to achieve quality. There is a need for systems in order that "... human, administrative and technical factors affecting quality will be under control... and this...enables the objectives set out in the quality policy to be accomplished." (Oakland, 1993). Inspection and the activities for quality control are the minimum system which a company must establish to control the quality of its products and services. However, in order to be more effective, an organisation should also set up a system for quality assurance. Quality assurance is defined as 'all those planned and systematic actions necessary to provide adequate confidence that a product or service will satisfy given requirements for quality' (ISO, 1986). In some types of industry, for example the pharmaceutical industry, GMP (Good manufacturing Practice) is a basic quality system which is required by the Thai FDA. The TFQSS has been demonstrated to be another type of basic quality system, which provides an organisation with an effective quality assurance infrastructure and covers the minimum of quality activities for Thai industry though it is still a 'foundation level' quality system. International standards, i.e. ISO 9000, which are

---

broader and more systematic approach to quality achievement, provide guidance that can be applied by companies to examine their activities, record what they actually do, and provide the basis for standardisation and improvement (Feigenbaum, 1991 and Oakland, 1993). The ISO 9000 series of quality systems and TFQSS implementation will be discussed again in section 8.4 and 8.5 respectively.

### **8.2.1.2 People**

People are critical for successful implementation of quality management. No matter how well established the systems are or how many techniques are provided, if people in an organisation do not understand the system of their organisation and do not know how to apply the quality techniques necessary in their jobs, a company will face failure in its quality journey. Awareness of quality should be reinforced among people in an organisation by 5-S practice and quality awareness training. To embark on the quality journey, employees should be seen as an asset. They should be continually developed and provided with adequate training and education, especially in a developing country such as Thailand where basic education for many workers is limited. Failure to give proper education and training can cause ineffective progress. Particular training for specific group of people at a particular time should be considered (Juran and Gryna, 1993). And it should not be concentrated only on skill development but a balanced consideration should also be given to the psychological and motivational aspects of employees, so that they have the right attitudes towards quality (Hassan,

---



1996). Successful education and training programmes will lead to employee involvement and commitment.

Embarking on quality management requires employee participation in all activities relating to improvement. Well-educated and properly trained employees are a valuable resource and will be more effective. This powerful source of employees' empowerment can improve quality in a creative way, and consequently cost will be reduced and productivity can be increased (Kondo, 1997). Employees, led by management, should be totally committed to quality, and this can be achieved through QCCs or equivalent teams.

### **8.2.1.3 Techniques**

Tools and techniques are an integral part of quality management and are used to analyse, control, monitor and predict the quality of products and services to satisfy customers. There are various tools and techniques which can be applied in any organisation. Among the basic techniques that a company may need to ensure the quality of its products and services is statistical sampling which is commonly found in Thai organisations. The Seven QC tools, which are also widely used, are important for better quality and these tools can be applied for problem solving and continuous improvement. However, it was reported in the survey study in Chapter 4 that less than fifty per cent of the companies responding to the questionnaire applied such problem solving techniques in their companies. Also, only twelve and eight per cent of respondents respectively reported that they applied QFD and Taguchi techniques. It is obvious that the more advanced techniques are less widely used in Thai organisations. Nevertheless, it should

---

be noted that the quality techniques and tools can improve quality of products and services so that the company can compete in local and export markets.

### **8.2.2 Stages of development and implementation paradigms**

The second dimension of the framework provides stages of development which in Thai organisations can be classified into five stages: - the unaware stage; basic stage; developing stage; mature stage; and sustaining stage. A description of the typical characteristics of each stage follows.

#### **8.2.2.1 Unaware stage**

The first stage of development of quality management is the unaware stage. Companies which are in this stage are typically very small and/or family-owned businesses. They have no formal system of control quality for their products and services, and they do not use any kind of tool and technique at all in their organisations. People who work in an unaware-stage company usually just do their job, often with carelessness about quality since they are not provided with training or education on quality. Management in these companies are typically fire fighting. Quality problems 'suddenly occur' and need to be solved immediately, usually by the top manager who is generally the owner. There is no quality planning, monitoring and control, not to mention improvement, in these companies.

In a small company with few workers, perhaps 10-20, it seems as if quality systems and techniques are not necessary, since management may be able to manage and also cope with most problems effectively. However, for the management to be more efficient and have a vision to lead their company

---



towards better performance and profit, more formal quality management is necessary. Moreover, if a company expands or becomes bigger, it needs to develop some suitable approach to organise for quality, in order to control and ensure the quality of its products and services. Hence, for a company to compete effectively and survive in turbulent markets, it is important that they improve their standard to the next stage of development.

#### **8.2.2.2 Basic stage**

It can be suggested that most Thai organisations, particularly SMEs, are in the basic stage of the quality management framework. As in other countries, QC was applied first in industry and was later developed to more systematic QA system. Quality planning for inspection of incoming material and in-process product, as well as final inspection are crucial. However, many Thai companies do not have a full QA system because they started their business with perhaps only ten workers and did not realise the necessity of quality control until they were frustrated by problems such as high reject rates, a large number of customer complaints, hectic production, etc. They then started setting up a system, however they develop only a basic QC/QA function, using simple techniques such as sampling plans, to control the quality of their products and services.

Employees in Thai companies, especially operators, have little education. They are not given enough education and training by management because of the notably high turnover rate of the unskilled workforce. Nevertheless, the management in a basic stage company may try to make such

---

employees become more aware of quality through effective communication and proper education and training.

In short, a company in the basic stage has basic quality system and applies some basic tools, e.g. statistical sampling. The workforce in a company in this stage should be encouraged to recognise and be aware of the importance of quality through activities such as 5-S practice and awareness training.

### **8.2.2.3 Developing stage**

In the developing stage, a company may have a more complicated quality system such as one based on the ISO 9000 series of quality systems standards, but this not always necessary. People in such an organisation are typically more involved in quality activities, for example quality improvement projects, perhaps through QCCs, and they are trained and provided with techniques, i.e. SPC and seven QC tools, to apply in their jobs. Most of the foreign-owned as well as big Thai companies are currently in this stage. In the medium term future most Thai SMEs should also be able to achieve this stage of development through the effects of implementing ISO 9000. However, they also need to encourage employees to participate and be involved in all activities concerning quality improvement, as there is evidence that ISO 9000 if not well implemented does not encourage company employees to participate in quality activities. More tools and techniques have to be provided to the workforce and taught so that they can be applied properly.



#### **8.2.2.4 Mature stage**

The mature stage is seen in an organisation that is committed to quality, and the concept of the internal and external customer is well understood by all its employees. They have enough knowledge not only to solve problems as they occur by themselves but also to create new processes or procedures in their jobs, to improve quality, prevent problems, reduce costs and increase productivity. A company in this mature stage can effectively integrate the systems they have, together with people and techniques. Systems may be flexible since all employees are committed to quality and have advanced tools and techniques to help them work on quality improvement by themselves. At this stage, an organisation can use business excellence quality models, such as the Thai NQA, to examine their organisation.

#### **8.2.2.5 Sustaining stage and implementation paradigms**

As the quality management journey is an ongoing process and the target should be continuous and 'never ending' improvement, an organisation which has successfully reached the mature stage needs to keep up its momentum to maintain quality. However, after a company has gone through its quality journey for some time, it will become difficult to maintain or continue with the same approach because that approach may eventually lead to diminishing returns (Whittle *et al*, 1992). Hence, the framework provides the sustaining stage with a third dimension, which is that of implementation paradigms, in which an organisation to examine for themselves as to which paradigm they were operating in when they first reached the mature stage, and

---

select a new paradigm to refresh the motivation of their companies and maintain momentum.

In summary, the framework of quality management in Thailand provides an understanding of the overall picture for Thai industry and provides a means to examine themselves. Moreover, it can also be a guide for Thai industry to embark on its quality journey.

### **8.2.3 Evaluation of companies against the framework**

Figure 8-2, 8-3 and 8-4 give examples of evaluation of the status of participating companies for each of the three research projects in this study. As shown in Figure 8-2, it can be seen that all three companies which participated in the TQM study; Siam Refractory Industry (SRIC), Toshiba Consumer Products (Thailand) (TPT) and Read-Rite (Thailand) (RRT), are at either the mature or sustaining stages in terms of system and techniques. As SRIC and TPT have already had a long quality journey, they are in the sustaining stage. RRT, which started its TQM project three years ago, is now entering the mature stage. However, with respect to the employees, only TPT seems to be able to achieve real company-wide quality consciousness and commitment to quality. Whilst employees of SRIC are in a developing stage, the RRT employees are only in the basic stage. In terms of implementation paradigms, as described in the TQM study in Chapter 6, these companies are representative of different paradigms.

An equivalent evaluation of the five companies participating in the ISO 9000 study is illustrated in Figure 8-3. They were either in the unaware or

---



---

basic stages before implementation of their ISO 9000 quality systems. In the aspects of system and techniques, two of the collaborating companies were in the unaware stage while the other three were in the basic stage, and it is not surprising that all five companies were in the unaware stage in terms of people aspects. However, after they have established a quality system complying with ISO 9002 requirements, every company could be classified as in the developing stage. However, the involvement of employees, especially at low level such as shop floor operators, was still lacking although quality awareness was obvious in these companies, as was the application of tools and techniques. Hence, it should be noted that companies that have progressed from the unaware stage to the developing stage by implementing ISO 9000 might not yet have their people and techniques in the developing stage, but only in the basic stage as shown in Figure 8-3.

In Figure 8-4, the four companies studied in the TFQSS project, excluding the pharmaceutical company, all were in an unaware stage for all three aspects of quality management. After they implemented the TFQSS, they entered the basic stage and show potential to go forward to the next stage, which is the developing stage.

As regards the quality management implementation paradigm, although a formal analysis was not undertaken, the author considers that all companies in both the ISO 9000 and TFQSS studies were operating in a VTQ paradigm. Whittle *et al* (1991) stated that 'there is greater chance of organisations which begin with the 'VTQ' moving successfully into the 'PTQ' and 'LTQ' models than vice versa. Failure to adopt 'VTQ' at some

---

stage.....usually gives rise to the “headless chicken” scenario’. This study also reinforced the widely-held view that the initial phases of a quality programme need strong management leadership and commitment



Figure 8-2 Evaluation of TQM framework of the companies in the TQM study

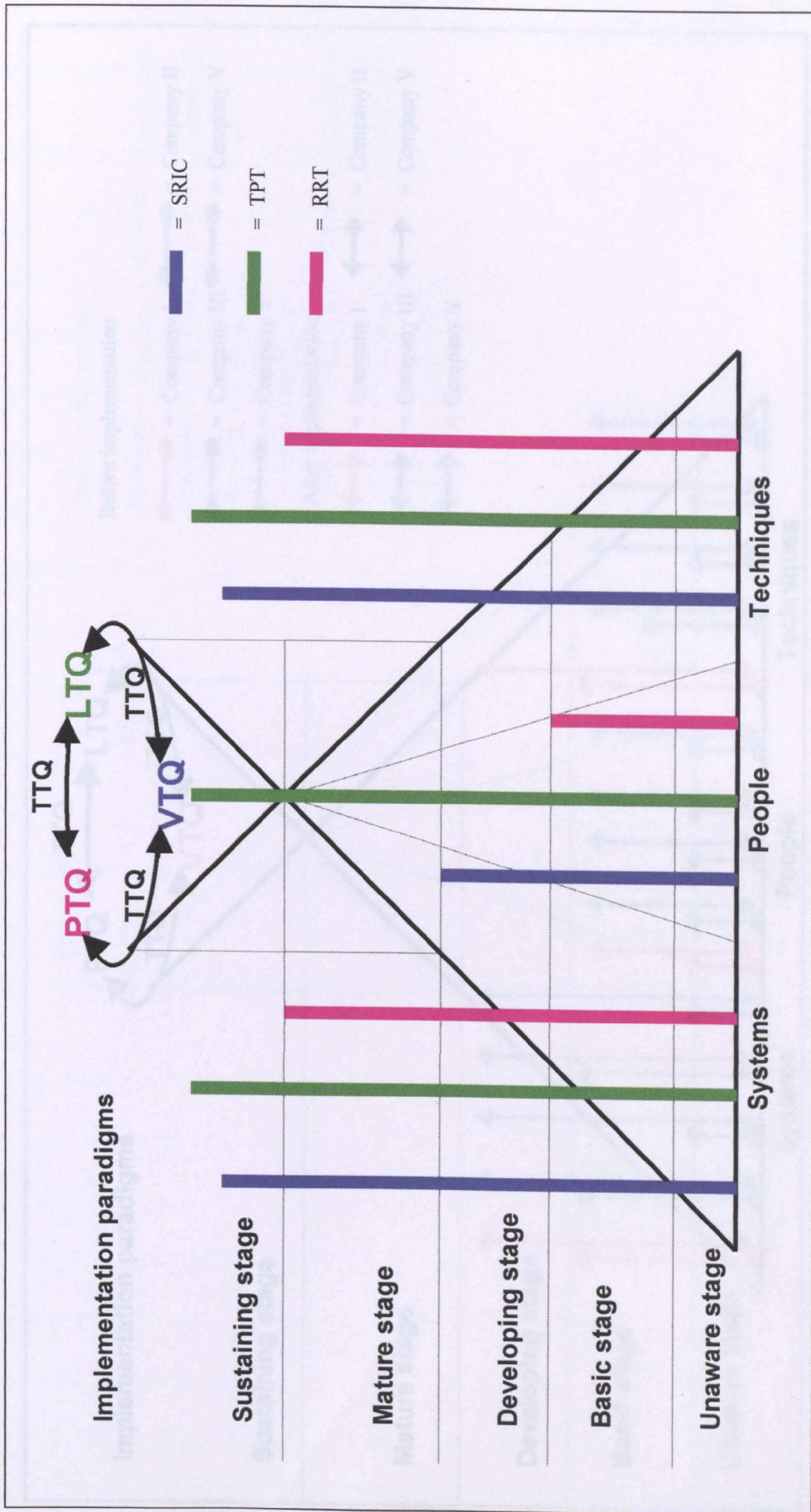



Figure 8-3 Evaluation of TQM framework of the companies in the ISO 9000 study

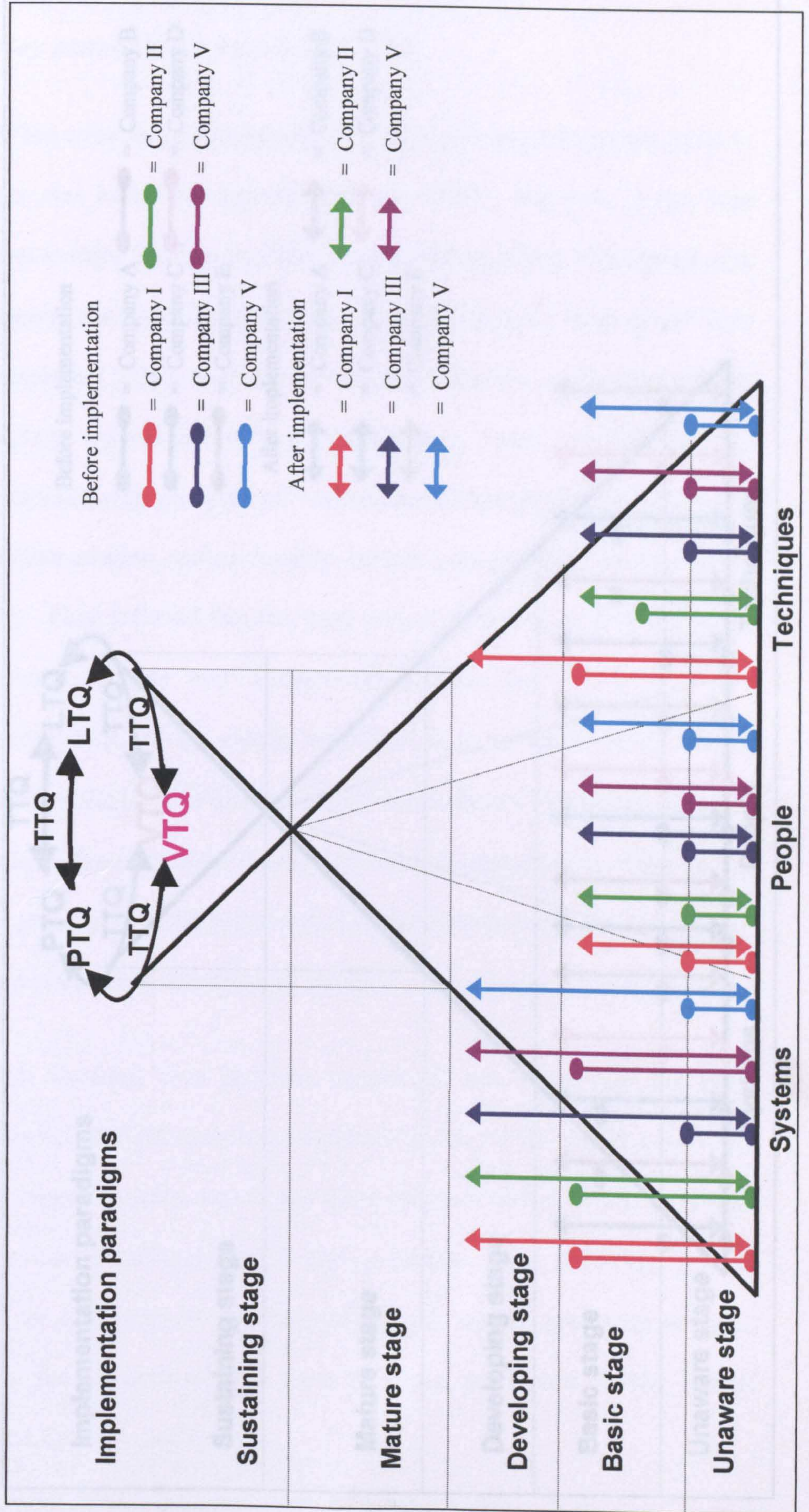
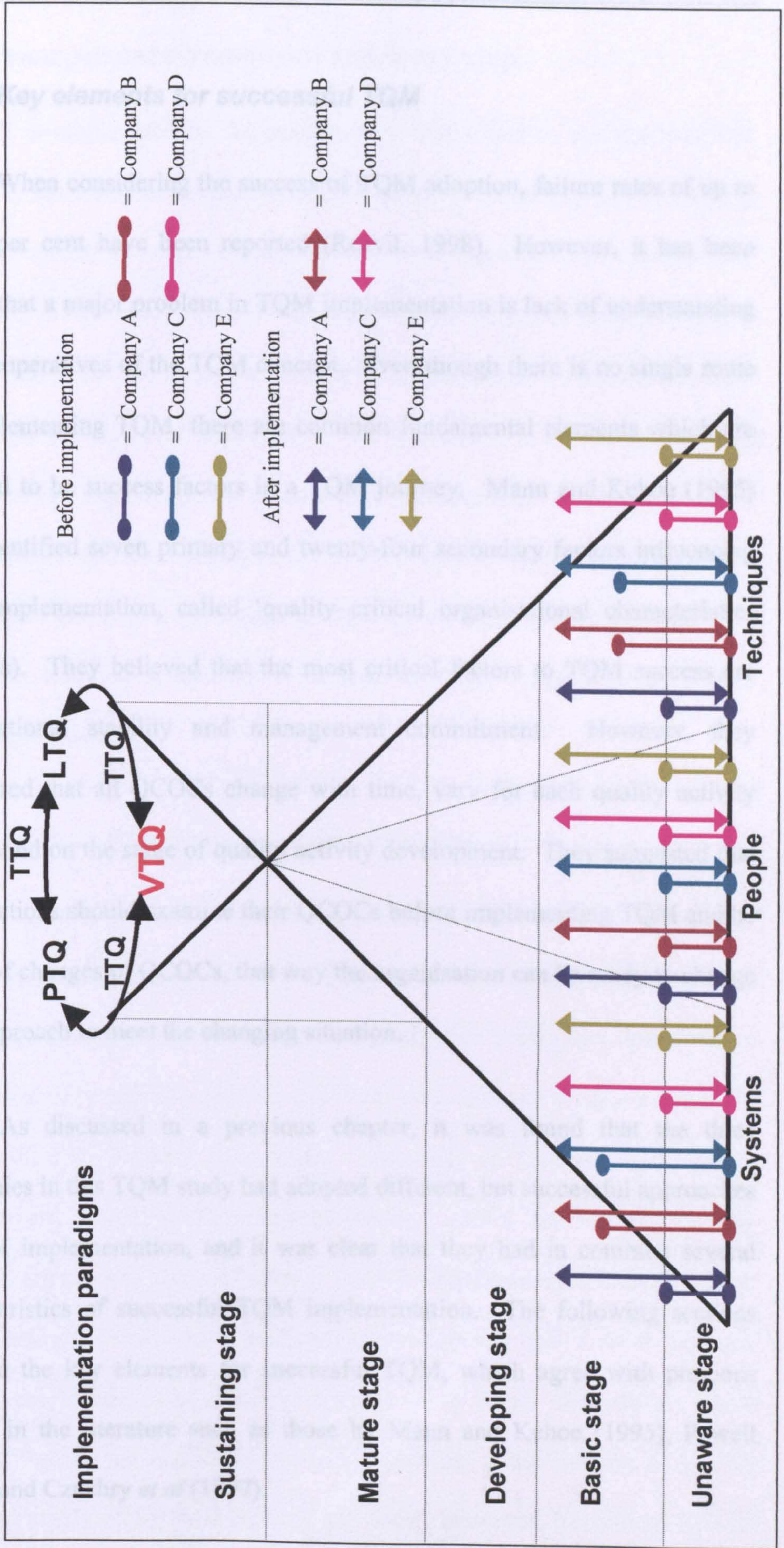



Figure 8-4 Evaluation of TQM framework of the companies in the TFQSS study





### **8.3 Key elements for successful TQM**

When considering the success of TQM adoption, failure rates of up to eighty per cent have been reported (Reavil, 1998). However, it has been argued that a major problem in TQM implementation is lack of understanding of the imperatives of the TQM concept. Even though there is no single route for implementing TQM, there are common fundamental elements which are accepted to be success factors in a TQM journey. Mann and Kehoe (1995) have identified seven primary and twenty-four secondary factors influencing TQM implementation, called 'quality critical organisational characteristics (QCOCs)'. They believed that the most critical factors to TQM success are organisational stability and management commitment. However, they considered that all QCOCs change with time, vary for each quality activity and depend on the stage of quality activity development. They suggested that organisations should examine their QCOCs before implementing TQM and be aware of changes of QCOCs, that way the organisation can be ready to change their approach to meet the changing situation.

As discussed in a previous chapter, it was found that the three companies in this TQM study had adopted different, but successful approaches to TQM implementation, and it was clear that they had in common several characteristics of successful TQM implementation. The following sections describe the key elements for successful TQM, which agree with previous studies in the literature such as those by Mann and Kehoe (1995), Powell (1995) and Czuchry *et al* (1997).

---



### **8.3.1 Management commitment and leadership**

It is emphasised by all practitioners that effective management and leadership are essential in order to embark on a successful TQM journey. It is the responsibility of senior management to encourage trust and involvement. According to Juran and Gryna (1993), commitment to quality is important, but it is not sufficient alone, active leadership by management, including senior and middle management; supervisors; and specialists, is also required. It is one of the key ingredients for successful TQM adoption. A deep respect for one's superior and for seniority is one of the particular aspects of Thai culture. This feature can help a management, who are committed to quality and have leadership abilities, to lead the workforce and their company to successful TQM implementation.

### **8.3.2 Teamwork and employee involvement**

Organisations that are on the TQM road use teamwork as their vehicle for change and mechanism for involving people in quality improvement. Most organisations that implement TQM encourage their employees to be part of quality teams in order to identify problems and solve them, and to look for opportunities to improve their work. Examples of teamwork are quality improvement teams; cross-functional teams. QCCs are one of the key Japanese approaches that are believed make a significant contribution to their quality success. Teamwork should start at management level to be an example to their employees. Compared with some other Asian nationalities, Thais consider themselves as a workforce to be relatively individualistic, as a result it might be difficult for them to work as a team. However, freedom of thought

---

during brainstorming sessions and reward and recognition for good teamworking can motivate people to recognise the importance of working as a team.

### **8.3.3 Employee training and development**

Human resource development is considered to be a key success factor in TQM implementation. As mentioned in the previous section people are one of three important aspects of TQM framework, and education and training of people are vital in quality improvement programmes. Most of Thai manufacturing industry is composed of labour-intensive operations and more than 70% of Thai workers have only primary school education (Sheehan, 1998). As described in Chapter 3, to become technologically more advanced Thai industry needs to upgrade its capabilities and this requires skilled labour. However, Thailand may not have enough educated and skilled labour to serve the demand of an advance technological industry (Chantramonklasri, 1997). Hence, continuous education and training driven by the company are crucial issues to develop their employees to be a valuable resource for company.

### **8.3.4 Effective communication within the organisation**

Good and effective communication between management and their employees is considered vital for TQM implementation. Employees' attitudes and behaviour can be influenced by effective communication. Management level staff should be trained in communication skills (Oakland, 1993). Again, one of the key characteristics of Thai people is their independent nature. It is important to provide information and get them to be involved in quality

---



programme since a lack of information might frustrate people and the consequence is resistance from workforce. Effective communication can bring about good relationship between management and the workforce in Thai organisations.

### **8.3.5 Customer focus**

Customer focus implies determining what the customers want and need because if an organisation understand its customers' requirements, it has the opportunity to supply its customers with products or services that fill them with surprise and delight (Bergman and Klefsjo, 1994). It should be stressed that the customer means both external and internal customer.

### **8.3.6 Performance measurement**

Performance measurement is the key indicator of quality improvement. It is important for an organisation to set long-term and short-term objectives in TQM implementation and continually measure whether the set targets have been achieved. It is also important that the quality performance measurement be well defined. Competitive benchmarking has been reported to be one of the tools that can be applied as part of the planning and vision setting phase of the TQM implementation programme (Terziovski *et al*, 1996).

### **8.3.7 Continuous improvement**

TQM is a 'never ending' process and the target should be continuous improvement. Using tools and techniques, such as problem solving tools, is important for quality improvement. All employees including front line

---

operators should be provided with education and training to develop their capabilities to improve their own work.

The Thai national culture has many of the social qualities which would support effective implementation of a variety of approaches to TQM. The companies in the TQM study clearly demonstrated that both Japanese-style and American-style approaches to TQM can be effectively implemented with a Thai workforce. The researcher predicts that the influence of both Japanese and Western TQM practices will tend to permeate from the larger organisations featured in this study, to the many smaller Thai companies who are currently interested primarily in ISO 9000 series certification.

#### **8.4 *ISO 9000 series of quality systems standards***

It is certainly the case that ISO 9000 series of quality systems standards has improved quality awareness in Thai industry. Not until 1990 was the ISO 9000 series adopted as Thai national standards, previously quality management in Thai owned companies was usually managed informally. Even though the number of certified companies has tremendously increased since 1992, it is however relatively low compared with some other Asian countries, and an ISO 9000 series certificate will often be advertised widely by its proud possessor. The following sections summarise and discuss the important results of the ISO 9000 study.



### **8.4.1 The implementation issue**

The results from the survey and the action research described in Chapter 4 and 5 respectively reveal critical aspects of ISO 9000 implementation in Thailand. These are the reasons for implementation and the implementation process as well as success factors and obstacles.

#### **8.4.1.1 Drives for pursuing ISO 9000**

The driving forces which encourage Thai industry to pursue ISO 9000 come from both external and internal influences. In the survey study as explained in Chapter 4, it seems that Thai companies had strong internal motives for seeking ISO 9000 certification. However, the results from the action research on ISO 9000 implementation indicated that the main motives which initially persuaded the five case-study companies to go for ISO 9000 appeared to result from external influences. However, after they had been implementing the system for some time they realised the potential and sought ways to obtain the maximum internal benefits from the process. Apart from the well-known international acceptance of the standards, incentives and support from government are some of the main external drivers for companies to pursue ISO 9000.

#### **8.4.1.2 Implementation process**

The implementation process in general consisted of six main steps: training, documentation, implementation, internal quality audit, corrective action and registration audit. A simple model identifying four types of ISO 9000 implementation process was used to illustrate implementation progress

---

under various conditions, based on the speed of the process and the progress style. The possibilities are fast-continual, slow-continual, fast-intermittent and slow-intermittent implementation process. The features of these are extensively described in Chapter 5.

#### **8.4.1.3 Implementation factors and obstacles**

Identifying the implementation factors and obstacles in the ISO 9000 implementation process are crucial because companies which decide to pursue ISO 9000 will be assisted to foresee potential problems and be prepared to overcome them. **Teamwork**, consisting of the right management levels, plays a very important role in the implementation process. **Top management** is also important in terms of leadership and support. **Resistance from the workforce** can inhibit progress of the implementation process. **External influences** can help or hinder the project. For example, the Thai financial economic turmoil set back most of the case study companies in the ISO 9000 implementation process. **Working with standards documents, language difficulties and interpretation** are also particular problems for Thai industry. Infrastructure to support the implementation process is also lacking - this is discussed in the next section.

#### **8.4.2 The national impact on Thailand**

It can be concluded that ISO 9000 has had a significant impact on Thailand as a nation. After ISO 9000 series were adopted as national standards, they became a big issue in the country since they were widely accepted and promoted by Thai industry as part of an effective strategy for

---



competitive advantage in the global market. From this study, it was discovered that there is no complete infrastructure system to support Thai industry in meeting some of the requirements of ISO 9000.

#### **8.4.2.1 Impact on quality awareness among Thai**

ISO 9000 has become a quality logo for Thai companies. When they successfully achieve an ISO 9000 series certification, they normally celebrate and advertise it widely. Most of the big companies in Thailand, including both Thai-owned and foreign-owned, were pioneers in acquiring ISO 9000 certification. They promoted their successful registration through the media such as television and newspapers. These promotional activities by the pioneering companies motivated the general Thai public to be more aware of quality. However, as those more expert know, certification to ISO 9000 does not always mean a quality product or service.

#### **8.4.2.2 Impact on infrastructure requirements**

It has been revealed that calibration system is one of the main obstacles for companies in Thailand. There are not enough laboratories to provide traceable calibration service to companies in order to meet the requirement (clause 4.11) of ISO 9001/2/3. The requirement is that the measuring equipment used must be calibrated and the calibration shall be traceable to national or international standards.

Good quality ISO 9000 consultancy is another issue. Due to the fact that the language issue causes some difficulty to practitioners who usually prefer to use their mother tongue, this leads to strong demand for good

---

consultancy services which can help Thai industry interpret the standards and also provide them with quality management expertise and knowledge. However, because quality management as well as ISO 9000 quality systems standards are both relatively new issues in Thailand, there are few competent professional consultants, and it is very expensive to hire one to help a company establish its quality system.

#### **8.4.2.3 Impact on education requirements**

Education has long been a problem for Thailand. In spite of an emphasis on education and human development in the most recent economic and social development plans, Thailand's education system is still behind those of most neighbouring countries. Only approximately 40% of Thai children attend secondary school, compared with about 50% in Indonesia, 60% in P.R.C. and Malaysia, 70% in Singapore, 75% in Philippines and 90% in South Korea and Taiwan (The Economist, 1997). Most of the workforce in manufacturing industry are drawn from people who have only a primary school education. Although the current minimum amount of education in Thailand is six years, about 75% of Thai workers have only four years of education (Bangkok Post, 1997). Hence they are not familiar with documentation and paperwork. The common practice in daily work is to follow a supervisor's verbal instructions. ISO 9000 quality systems implementation enhances the education requirement since a documentation system needs to be established and the workforce should have ability to work with documents, such as written work instructions.

---



### **8.4.3 Impact on organisation**

It is clear that if companies implementing ISO 9000 go through the process of implementation consciously, their organisational culture will gradually change since an effective implementation process requires the involvement of employees and an improvement of their understanding of quality. Four aspects of the impact of an ISO 9000 implementation process were identified through a reversed cause-effect diagram shown in Chapter 5. These are classified as structural, process, cultural and management changes.

### **8.5 Basic quality system**

Having identified that majority of Thai industry are SMEs, many of which are family-owned and managed with few formal business systems. Such a traditional Chinese style of management/business culture is typical of Thailand's manufacturing industry. Successful quality systems implementation needs genuine management commitment. It is necessary for management staff who are family members to be convinced that quality is essential for their business. Although the ISO 9000 series of quality systems standards is addressed as an entry-level standards for international markets, for Thai SMEs it is regarded as a complicated system due partially to difficulties with language and interpretation. In addition, the coming ISO 9001:2000 version of the standards appears to be more like a process-oriented business excellence model.

There are strong indications that trying to jump from scratch to a complicated system can be a frustrating process and discourage people in

---

moving forward on a quality journey. Setting achievable goals and meeting them first would encourage people in an organisation to see ways to continue with their quality programme. Indeed, the TFQSS which is a 'foundation level' quality systems standard and has been proved to be easier to understand and implement, is suitable for Thai SMEs to start with.

Competent and professional consultants can help companies understand the requirements of the TFQSS standard and take the first step towards meeting them. Therefore, appropriate advice and assistance should ideally be made available at economic consultancy rates to SMEs wishing to adopt the standard. This may be a policy issue for Thai government agencies.

The external audit approach has been found to be a strong motivation on Thai companies to achieve the standard requirements. Hence, an official certification process should be made available to allow recognition at national and international level for companies achieving the standard.

## **8.6 *Policy implications for Thailand***

Although this study was not originally designed to focus on government policy issues, it has revealed some interesting points for government to consider. It is notable that the infrastructure to support Thai industry in implementing quality management is somewhat lacking. Unless this need is met, Thai industry might lose its chance to be competitive not only in export markets but also in its domestic market. Certain issues that should be tackled by government are identified and discussed below.

---



### **8.6.1 Education**

It is generally accepted that human resource is the most important factor for a nation to be able to develop economically. As discussed in the previous sections, Thailand lags behind neighbouring countries in the number of educated people and in skilled labour. It has been confirmed by this study that a Thai workforce is not familiar with documentation work due to their low educational level. In the near future, Thai manufacturing industry will be shifting towards more advanced technology and automated systems which will also require a workforce that has the capability to adapt themselves, be flexible and be willing to learn new things in their jobs. It will be very difficult for a Thai workforce with low education to do this effectively.

Continuous education and training could provide an opportunity for the Thai workforce to improve their capability. As the turnover rate of workers is usually high in Thailand, companies might not be willing to provide education and training to their workers to a great extent. However, this matter should not be overlooked by government. Support and incentives should be made available for companies which give their workers a chance to improve their capability through education and training.

### **8.6.2 Calibration systems**

Most of companies studied in this research had difficulty getting their measurement and inspection equipment calibrated, for two reasons. First, they did not have a great deal of knowledge about metrology and most of them had never been concerned about such matters before. Actually, some types of

---

equipment can be calibrated within the company and it would be more convenient, cost effective and time-saving for a company to have their own calibration system which should be of course traceable to national or international standards. However, they may not have enough knowledge to set up the required facilities. Therefore, they need an outside calibration service for almost all the equipment in their factories. This uncovered the second problem, in that Thailand has too few calibration laboratories to serve the demand from Thai industry. According to Sripaipan (1994), there were then only five main organisations that provided calibration services to the private sector and these had together calibrated only about 15,000 items of equipment in 1993. A visit to one of these laboratories in 1997 revealed a large backlog of work awaiting calibration, including many simple steel rules.

The importance of metrology and knowledge of the subject area needs to be promoted in Thai industry. This is one of basic disciplines for manufacturing industry to produce products and services which conform to specified requirements.

### **8.6.3 Certification and accreditation systems**

In order to help Thai industry to be competitive, ISO 9000 has been promoted as one of the tools to penetrate international markets. After some delay, a national scheme for certification and accreditation has now been set up so as to support ISO 9000 system registration. However, it is vital that such a system must be internationally accepted so that it can really help Thai industry in export markets. Like the PSB in Singapore and SIRIM in

---



Malaysia, the ISO institute which was established in 1998 to take over the certification task from TISI, should consider making mutual agreements with well known certification bodies that are internationally recognised, so that it can compete with foreign certification bodies and maintain a suitable assessment cost for Thai industry.

It was found in the TFQSS study that an external audit approach has strong motivating impact on the companies to achieve the standard TFQSS requirements, an official TFQSS certification process which is accredited by TISI should be made available to allow recognition at a national and international level for companies achieving the standard. Certain Thai government agencies have functions in similar areas, such as the ISO institute, and should be encouraged to collaborate with NSTDA in implementing the TFQSS as a Thai national standard with appropriate back-up and marketing.

#### **8.6.4 Professional and qualified consultants and assessors**

There is currently a great demand for quality management consultancy services in Thailand. It is clear from this study that Thai companies, particularly SMEs, do not have enough knowledge on this matter and often need to seek assistance from external consultants. However, if consultancy is too expensive for them, these companies will not have the opportunity to improve their quality management. Only a limited number of local qualified consultants are available to provide professional consultancy services to Thai SMEs. Moreover, there are very few materials in Thai concerning quality management which are simple and easy to use by practitioners. It is therefore

---

suggested that government should encourage Thai SMEs to learn by themselves, by providing simple tool kits to enable them to examine their organisations and design suitable implementation, with less external assistance or even without any external assistance.

Professional and qualified quality systems assessors who are locally-based and who can communicate well in Thai are also very scarce. It should be a government matter, to ensure an appropriate number of qualified auditors to undertake quality auditing in Thailand. Along with the accreditation scheme that TISI operates, ensuring the competence of the auditors and perhaps registering them is another function that TISI should take responsibility for.

#### **8.6.5 Research and development**

There is very little research and development in the area of quality management in Thailand. Most of Thai companies are not interested in doing this kind of research and seldom collaborate with academic institution to carry out research. As the application of quality management varies according to culture, location, type of industry and so on, Thai organisations with their unique characteristics should be studied in their own context in order to gain knowledge that is specific to the Thai aspects. Thai practitioners and industrialists should be encouraged to do research in their own organisations or co-operate with research and academic institutes so that the knowledge on quality management and its application can be useful both to themselves and other Thai organisations.

---



### **8.7 *Quality management in developing countries - A model***

As described in Chapter 2 and 3, quality management in developing countries including Thailand has been established and developed in much the same way as with developed countries. Having discussed quality management in Thailand extensively in previous sections of this chapter, consideration will now be given to quality management in other developing countries. This section suggests some criteria for the assessment of national development in quality management, in order to draw up a comparative ranking of quality development, especially in the South and East Asian region. The criteria that are helpful to position the status of a particular country are discussed in the following sections and are also summarised in Table 8-1.

**Table 8-1 Criteria for assessment of national development of quality management**

<b>Criteria</b>	<b>Unaware stage</b>	<b>Basic stage</b>	<b>Developing stage</b>	<b>Mature stage</b>	<b>Sustaining stage</b>
<b>1. Nation-wide promotion of quality through education and training</b>	None	Mainly by government	Mainly by government but private sector begin to be actively involved	The government still plays an important role by co-operating with private sectors	Mainly by non-profit organisations which are private sectors
<b>2. Competent consultants</b>	None to very few in number	Very few local competent consultants, need to import foreign consultants	Start to develop local consultants, using fewer foreign consultant	A number of local consultants who are competent. Start of national professional bodies.	A large number of professional consultants. Established profession.
<b>3. Standardisation and accreditation system</b>	None	Setting up a national standard body to take charge of standardisation and accreditation.	The national system is more established but still has deficiencies in coverage/scope	Have had a complete standardisation and accreditation system for some times	Certification and accreditation system is robust and mature
<b>4. ISO 9000</b>	Very few companies	A small number of companies and most of them are exporters	More companies but most of them are big companies	A large number of companies and local companies including SMEs	Almost all (if they want), reaching saturation point



<b>Criteria</b>	<b>Unaware stage</b>	<b>Basic stage</b>	<b>Developing stage</b>	<b>Mature stage</b>	<b>Sustaining stage</b>
<b>5. TQM</b>	None	A few companies, most of them are joint venture and foreign owned	Spreading to the more advanced local companies	A large number of companies implement TQM	TQM is well known and implemented widely in industry.
<b>6. NQA</b>	None	Setting up a National Quality Award process	Launching NQA programme, limited understanding or take-up in industry	An established NQA for some time, companies using the criteria	NQA is well developed and widely used. Many applications.
<b>7. Perception of quality level in global market</b>	Very poor	Poor but cheap	Medium and cheap	Good and reasonable price	Excellence and good price
<b>8. R&amp;D</b>	None	A few isolated industry projects	Limited and mainly in government, academic institutes and big companies	Starting to have co-operation between academics and industry practitioners	R & D is common

### **8.7.1 Nation-wide promotion of quality through education and training**

Promotion of quality at a national level is important to develop quality awareness among people, who are customers and consumers of products and services, and among companies, which are producers and suppliers. Workers of course are also consumers. The dissemination of quality awareness is necessary not only to enable companies to compete in local and international markets, but also to improve the quality of people's lives. It is common for governments and their agencies to play a crucial role in continuous promotion of quality activities in a country. However, private-sector involvement is also essential.

Whilst in developed countries which are generally classified to be in sustaining stage of the spectrum of quality development (as shown in Figure 8-5), non-profit organisations, for example ASQC in USA and JUSE in Japan, are very active in promotion of quality activities at national level, in developing countries where these do not exist the government needs to be more active in promotion of quality management. However, the role of government should gradually change to become a supporting role when a country develops their quality activities to more advanced stage. An important issue is the development of an effective national body to support quality management professionals, such as consultants and practitioners, and encourage quality management in industry.



### **8.7.2 Competent consultants**

One of the main problems that obstruct the progress of quality prosperity in Thailand is a lack of competent consultants (Bhandhubanyong, 1999). It is confirmed by this study that Thai companies, particularly SMEs, do often need assistance from professional consultants. However, it takes a long time to develop competent consultants since it requires not only knowledge of quality matter but also experience to improve their capabilities.

The NICs, as well as Malaysia seem to be effective in developing consultants. They first sought help from their more developed counterparts. Countries such as Singapore, Malaysia and PRC are very active in inviting foreign lecturers (Sandholm, 1988). Regional offices of consulting firms from developed countries are based in these countries. Working with these firms can speed up the improvement of local consultants' capabilities. Indeed, small countries like Singapore have advantages because smaller numbers can fulfil the demands of the country. However, larger countries like Thailand, Indonesia and the Philippines should be more efficient in developing a body of qualified local consultants.

### **8.7.3 Standardisation, certification and accreditation systems**

Standardisation plays an important part in the development of a country's industry. It is normally associated with a product certification programme, which involves checking and certifying that products comply with the relevant standards. A country has to have a national standards body to be responsible for preparing national standards and providing the necessary

---

infrastructure to be used by industry. NIST in USA and BSI in UK are examples of organisations that have standardisation functions. Third-party certification provides consumers who buy products with confidence that such products are safe and meet specified requirements. Third-party certification can take various forms which might be combined together, such as type testing; audit testing and assessment (Sandholm, 1988). This leads to a demand for accreditation of organisations that provide testing service. In developed and industrialised countries, all activities concerning standardisation, certification and accreditation will typically be well-developed. However, such activities are less well-developed or in an early stage in developing countries.

According to available literature, all of the NICs and most of South and East Asian countries, except Laos, Cambodia and Myanmar, have established an extensive infrastructure of standardisation, certification and accreditation system. However, these are in practice at different stage as previously described in Chapter 2.

#### **8.7.4 The ISO 9000 series of quality systems standards**

As ISO 9000 is well known and accepted worldwide, the number of companies that are certified against the standards is an important indicator quality development in a particular country. However, there are many factors that influence ISO 9000 certification process in each country, for example the total number of companies in a country and size of the economy, etc. It is perhaps most appropriate to use the ratio of certified companies to the total

---



companies in industry of a particular country in order to compare between countries. Unfortunately figures of total industrial companies in a particular country are not available. Hence, in this study, an overall percentage of certifications is used taken from ISO data, which gives useful trend information over time.

As is shown in Table 8-2, Singapore is very effective and efficient in ISO 9000 establishment. In the earlier stage of ISO 9000 series introduction, Singapore through the PSB successfully encouraged companies in the country to register to ISO 9000 standards. Malaysia, Hong Kong and Taiwan had a greater share of ISO 9000 certified companies than others, except Singapore, during the first few years. Korea followed a little later. As China and India are very large countries with many economic problems compared to some others, they therefore took a longer time to make ISO 9000 prosper in industry, but their sheer size may soon overwhelm the figures of other countries.

Countries, such as Indonesia, Thailand and the Philippines, were quite slow to have a large number of certified companies compared to the NICs. However, they are still ahead of countries like Brunei, Myanmar and Vietnam.

**Table 8-2 Share in percent of selected countries in the ISO 9000 certifications (Calculated from the ISO survey, 1997)**

Country share (%)	Jan. 1993	Sept. 1993	June 1994	Mar. 1995	Dec. 1995	Dec. 1996	Dec. 1997
Brunei	0	0.2	0.1	0.1	0.3	0.4	0.7
China	1.9	2.9	6.4	6	7.8	26.7	20.8
Hong Kong	13.1	13.2	14.2	11.6	11.4	10.3	6
India	1.5	6	13.9	12.4	15.7	12.6	10.5
Indonesia	0.2	0.7	0.9	1.2	1.9	2.7	4.7
Malaysia	23.2	18.3	10.9	13.3	10.6	8.8	5.9
Myanmar	0	0	0	0	0	0.01	0.01
Philippines	0	0.3	0.5	1.7	1.6	1.2	2.3
Korea	5.1	7.1	9.6	8.2	9.5	7	21.2
Singapore	46.2	42.8	28.1	21.2	18.2	14.2	10.6
Taiwan	8.2	7.9	14.3	22.4	20.8	14.8	13.2
Thailand	0.6	0.7	1	2	2.2	1.4	4
Vietnam	0	0	0	0	0.01	0.01	0.05
Total %	100	100.1	99.9	100.1	100.01	100.12	99.96

### 8.7.5 Total quality management (TQM)

Adoption of TQM may be unavoidable if companies wish to be competitive in the global market. Nowadays, global competition is severer than ever. It should be national policy to educate people, especially executive management in organisations, to realise the important of quality management and how to embark on a quality journey. Izumai and Whitfield (1997) suggest that 'as Asian countries and states becomes more industrialized, stratified markets begin to become more unified, and the labour costs of 100%



inspection increase, the requirement of TQM implementation will likewise increase'. The number of organisations that implement TQM is, among others, an indicator of stage of quality development in a particular country.

It is impossible to acquire an exact number of companies implementing TQM in a particular country. However, the literature concerning TQM implementation in some countries such as Singapore, Malaysia and Taiwan, etc. provides a general sense of the prosperity of TQM in their countries. It seems that again the NICs have realised the importance of TQM implementation before their less-developed counterparts, such as Thailand.

#### **8.7.6 National quality award (NQA)**

A national quality award can be used as self-assessment criteria for an organisation which embarks on quality journey, to evaluate their status and progress. As an example, the US Malcolm Baldrige National Quality Award (MBNQA) was established in 1987 to 'promote an understanding of the requirements for performance excellence and competitiveness improvements and to promote sharing of information on successful performance strategies' (NIST, 1999b). It has been reported that this programme has had a significant impact on US national competitiveness and the success of individual companies (NIST, 1999c). The Deming Prize in Japan, the European Quality Award and other national quality awards have similar objectives to the MBNQA, but they have their own programme. Many national award criteria however are based on the MBNQA.

---

The NICs, such as Singapore, Taiwan and Korea have established NQAs to encourage and promote quality concepts in their industries. Vietnam has also launched a 'Vietnamese Quality Award' in 1995 (STAMEQ, 1999). Thailand is in the process of setting up its own NQA. However, substantial South and East Asian countries such as Indonesia and the Philippines have not yet shown any evidence of the establishment of a NQA.

### **8.7.7 Perceptions of quality level in the global market**

Because of globalisation, the world often seems to be 'smaller' than before. At present, it is much easier to design a product in one place but manufacture and supply it from another location on the other side of the world. Due to increasing free trade areas, products produced by companies in many countries can be supplied without tariff barriers into any market as long as there are customers to buy it. However, customer perceptions of the quality level of products from particular countries are differentiated. Quality of product is of course not dependent only on the management of quality in companies. There are many factors to be considered, for example indigenous raw materials and technology etc. However, a perception of quality level in a market is one of the criteria which can indicate how well quality management is developed in a country from which those products are sourced. Japan is the classic example. The reputation of Japanese products change dramatically after World War II, from 'bad' to excellent' products because of their progress in quality management.



Typically, the reputation of products from developing countries is not yet thought to be good. They are able to penetrate into markets on the basis of low price. Some of the NICs, especially Singapore and Korea, now have a quality reputation in some markets similar to that of European countries or the USA. On the other hand, there is virtually no perception of quality level for countries like Myanmar and Vietnam which have very little presence in international markets.

### **8.7.8 Research and development (R&D)**

As mentioned before, there are very few publications related to R&D on quality management in most developing countries. However, it is important that R&D is carried out in order to obtain knowledge that is specific to a particular national context. In developed countries, R&D is thought necessary and is widely conducted by academic, consultants and practitioners. Consultants might come from academic, and vice versa. They can contribute their knowledge and experiences to research and academic community which will be very useful for both practitioners and researchers. However, in the developing countries, such R&D is still in an early stage.

Using the criteria described above, quality management in developing countries can be shown against a developmental spectrum, as shown in Figure 8-5. The stages of quality management development already suggested in this study for individual companies have been used to help illustrate the comparative status of selected nations in what might be called their 'national quality journey'. The position of a particular country can be in between two

---



stages of development due to the various criteria taken into account. It has to be stressed that this model is somewhat speculative, and in the nature of a proposition or hypothesis, as it is based on a review of literature and on general knowledge about the selected countries. This model should be validated using primary data which cannot be done within the scope of the current study.

As shown in Figure 8-5, quality management in developed countries is classified as being in the sustaining stage. The so-called ‘gang of four’ NICs (Singapore, Hong Kong, Taiwan and South Korea) are moving from the developing stage to the mature stage. Malaysia is lagging behind, but moving up to join them. Among developing countries in the South and East Asian region, Thailand is in the middle of the spectrum of development.

**Figure 8-5 Quality spectrum of developing countries - A proposed model**

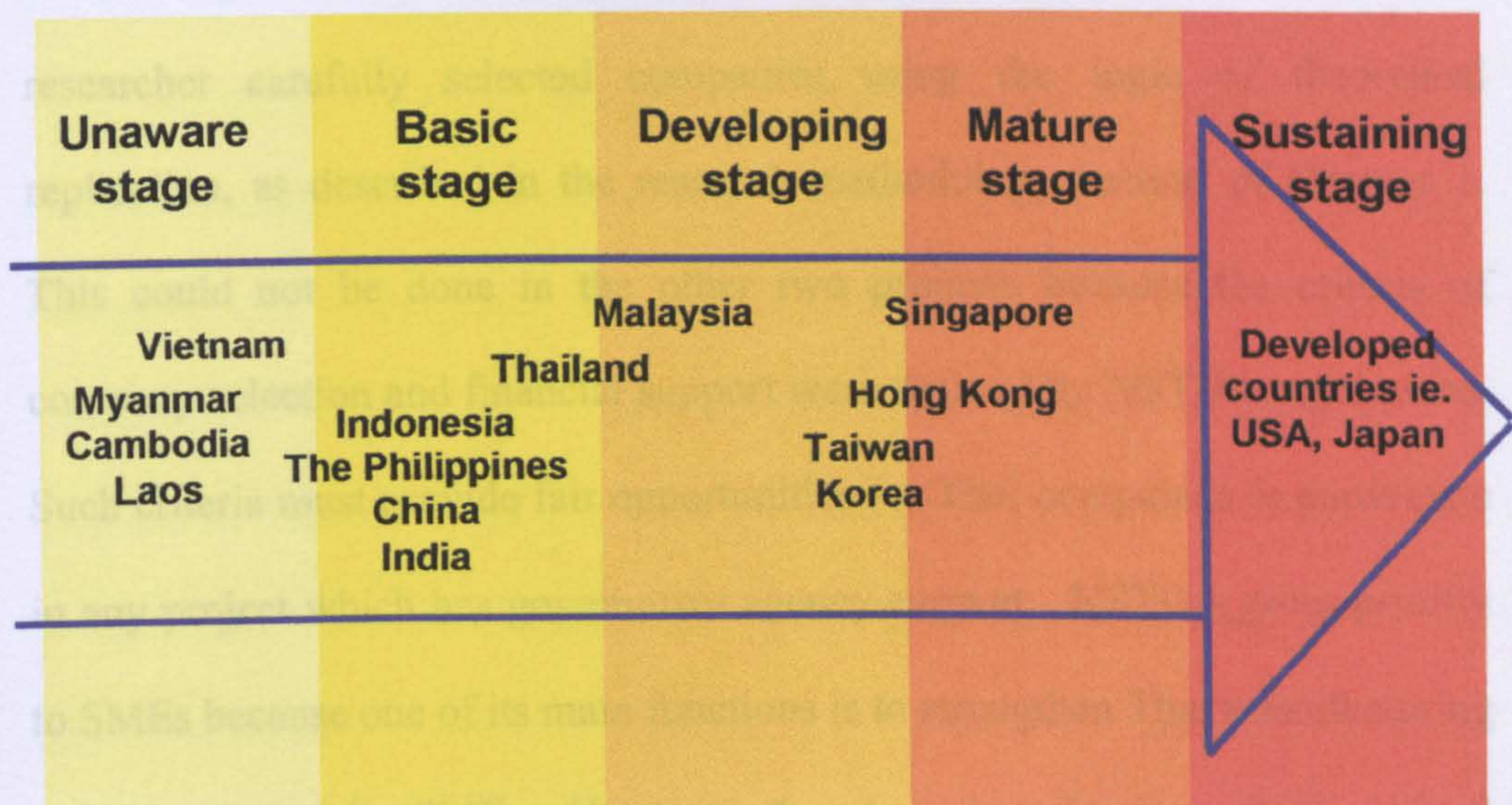



## **8.8 Limitations of the research**

As mentioned before, the objectives of this study were to investigate quality management in Thailand and to compare a Thai perspective on quality management with that of other developing countries. A carefully designed research methodology was employed to investigate these complicated issues. In this approach, there are however certain constraints and limitations that should be noted in order to clarify and justify the research contribution.

### **8.8.1 Selection of case study companies**

A case study research methodology was used in three of the research projects described in this thesis. As stated in Chapter 1, the rationale for selection of case study companies in the TQM project was different from the other two projects, the ISO 9000 and TFQSS studies, which were financially supported by NSTDA. This support involved both advantages and disadvantages to the individual research projects. In the TQM study, the researcher carefully selected companies using the logic of theoretical replication, as described in the research methodology section of Chapter 1. This could not be done in the other two projects because the criteria of company selection and financial support were defined by NSTDA regulations. Such criteria must provide fair opportunities for Thai companies to participate in any project which has government agency support. NSTDA gives priority to SMEs because one of its main functions is to strengthen Thai manufacturing industry, especially SMEs. However, the company selection criteria defined by NSTDA did not jeopardise the outcome of the research. Nevertheless, it

---

must be stressed that the study on ISO 9000 and TFQSS implementation was carried out in Thai SMEs for this reason.

### **8.8.2 Access to the companies**

In an empirical study, access is one of the important factors needed to be considered when planning the research. According to Gummesson (1991), access means 'the ability to get close to the object of study, to really be able to find out what is happening'. In the action research on the ISO 9000 and TFQSS projects, the researcher worked closely with the companies as one of the consultants provided by NSTDA. This gave her a great opportunity to collect data by various means such as participant observation, interview, documents, etc. The companies were open and willing to provide as much information as required by the researcher as a result of the good personal and professional relations that were built up during these lengthy externally-funded projects.

In the TQM study, it should be acknowledged that the researcher's ability to access the three companies was more limited. These were larger companies, the investigation was not funded by NSTDA, and access depended entirely on the good-will of company managers. Because of limitations of time and availability in the companies studied in the project, only a number of in-depth interviews, plant tours and company documents were used as the data collection method. Hence the findings of the TQM study were based mainly on what had been reported by informants during the interview, using a content analysis approach as described in Chapter 6.

---



### **8.8.3 Secondary data analysis**

Limitations of resource and time available made it impossible to obtain primary data from other developing countries. Hence, in the comparative study of quality management between Thailand and other developing countries, the analysis has been based on secondary data acquired from the literature and previous studies.

### **8.9 Further research**

As quality management has evolved in Thailand, it has brought together much of the learning about good management that has occurred across the country in recent years. However, it is still in its infancy and empirical research in this area is largely lacking. It is hoped that this study will help provide a foundation of knowledge on quality management in a holistic Thai context, and encourage Thai academics and practitioners to be increasingly interested in this research area. As this study has covered a wide-range of quality management issues, recommendations for further research arising out of it are numerous.

First and foremost it is important to further validate the TQM framework proposed in this study. It would be valuable to empirically test the framework in a number of scenarios, for example in a number of companies of the same type, size, area, etc.

Seeking co-operation between countries in the same region to obtain primary data for a comparative study of national quality development could be

---

carried out to confirm the proposed model of quality management in developing countries. This will provide a useful perspective for practitioners, especially in multinational companies, to apply in their organisations.

Since the study of TQM implementation in this research involved only three companies, which were Thai, American and Japanese owned companies, it would be of interest to study companies owned from other nations, such as Taiwanese and Korean companies, and also SMEs which have adopted TQM in their companies. This will provide useful information for TQM implementation in different nationally-owned companies operating in Thailand.

The TFQSS, which has been proved to be useful to small and medium manufacturing industry in Thailand, could also be tried with other types of industry, for example in the service industry and in public or non-profit organisations. Furthermore, a study on how to move from TFQSS to either ISO 9000 or TQM would be interesting to researchers and the business community.



### **8.10 Contribution to knowledge**

This final section summarises the results of this research study in terms of its contribution to knowledge. It is proposed that the research makes a worthwhile contribution to knowledge on both theoretical and practical levels as follows:

1. Previously, there were no known studies of the overall picture of quality management in Thailand. The proposed framework, developed during this study, provides insight and an overview of the development of quality management in Thai organisations. This contributes to academic knowledge. Moreover, the framework can also be useful to Thai organisations in terms of practical quality management development. An organisation, which wishes to embark on or progress in its quality journey, can examine its status against the framework in order to start, or improve a particular aspect that is found to be unsatisfactory.
  2. The model of quality management in developing countries depicts comparative characteristics of developing countries in terms of quality activities and infrastructure. This provides academic and practitioners with new insight into the development and implementation of quality management in developing nations.
  3. Apart from Q-Base Code developed in New Zealand, currently the TFQSS is the only basic quality system standard available for use. This basic standard is the greatest contribution at practical level to Thai industry resulting from this research. It has been proven to be easily understood
-

and implemented by Thai SMEs. Moreover, the companies implementing the TFQSS have shown that their organisations progress in so doing from the unaware stage of quality development to the basic stage.

4. As of today, there has been very little empirical work on ISO 9000. Most of the previous ISO 9000 studies that the author came across in the course of this research, were based either on survey methods or on anecdotal experiences of consultants/practitioners. Action research using grounded theory analysis, which was employed in the ISO 9000 study, has shown itself to be a rigorous study methodology and provides a greater opportunity for a researcher to get close to the important issues of ISO 9000 implementation.
5. Finally, the integrated survey and action research methodology used in this research has been demonstrated to be valuable and provide a choice of approaches which others may use to study quality management issues.

Finally to conclude, the primary objective of this research was defined as 'to draw up an overall picture of quality management in Thai industry and to provide a useful perspective for its implementation and to compare it with other developing countries'. The author would like to submit that this objective has been achieved, to a great extent.



---

## REFERENCES

- Abdul Rahman, H. (1993), "The management and cost of quality for civil engineering project", *Ph.D. Thesis*, UMIST.
- Adebanjo, O. (1997), "A framework for total quality management culture development", *Ph.D. Thesis*, University of Liverpool.
- Ahluwalia, J. S. (1997), "Spotlight - an individual's perspective on the quality movement in India", *Quality World*, Vol. 23 No. 11, pp. 912-914.
- Alcorn, J. E. (1995), "The benefits of ISO 9000 certification", *Proceedings of Ceramic Engineering and Science*, American Ceramic Soc., Columbus, OH, USA, 8-9 November 1994, pp. 15-18.
- Ali, A. R. (1994), "Implementing international quality system standards - the Malaysian experience", *Asia Pacific Journal of Quality Management*, Vol. 3 No. 3, pp. 28-35.
- Arphasilp, P. (1980), "Thailand", *Proceedings of Quality Control and Quality Assurance: The Asian experience*, Asian Productivity Organization, Indonesia, pp. 181-186.
- Bangkok Post (1997), "Thailand slips behind as warning ignored", *Bangkok Post*, 18 June 1997, Bangkok, p. 2.
- Barad, M. (1995), "Some cultural/geographical styles in quality strategies and quality costs (Peoples Republic of China versus Australia)", *International Journal of Production Economics*, Vol. 41 No. 1-3, pp. 81-92.
- Belohlav, J. A. (1993), "Quality, strategy and competitiveness", *California Management Review*, Vol. 35 No. 3, pp. 55-67.
- Bergman, B. and Klefsjo, B. (1994), *Quality - from customer needs to customer satisfaction*, McGraw-Hill, London.
- Bhandhubanyoung, P. (1999), "Major obstacles to the progression of quality management in Thailand", 8 February 1999, *Personal communication*, Faculty of Engineering, Chulalongkorn University.
- Black, S.A. (1994), "Measuring the critical factors of total quality management", *Ph.D. Thesis*, University of Bradford.
- Blythe, R. M., Rao, H. and Shahani, N. (1997), "TQM in Glaxo India - a step-
-

- 
- by-step implementation process", *The TQM Magazine*, Vol. 9 No. 2, pp. 98-105.
- BPS (1999), "BPS and its activities", June 1999, *Internet*; <http://www.dti.gov.ph/bps/bpsactiv.htm>
- Brown, A. and Wiele, T. V. d. (1995), "Industry experience with ISO 9000", *Asia Pacific Journal of Quality Management*, Vol. 4 No. 2, pp. 8-17.
- Brown, A., Wiele, T. v. d. and Loughton, K. (1998), "Smaller enterprises' experiences with ISO 9000", *International Journal of Quality & Reliability Management*, Vol. 15 No. 3, pp. 273-285.
- Brumm, E. K. (1995), "Managing records for ISO 9000 compliance", *Quality Progress*, Vol. 28 No. 1, pp. 73-77.
- Bryman, A. (1989), *Research methods and organization studies*, Unwin Hyman, London.
- BSN (1999), "National Standardization Agency", June 1999, *Internet*; <http://www.bsn.go.id/11P.HTM>
- Buttle, F. (1996), "The costs and benefits of ISO 9000", *Proceedings of The First International Conference on ISO 9000 and TQM*, De Montfort University, Leicester, 10-12 April 1996, pp. 71-78.
- Carlsson, M. and Carlsson, D. (1996), "Experiences of implementing ISO 9000 in Swedish industry", *International Journal of Quality & Reliability Management*, Vol. 13 No. 7, pp. 36-47.
- Cater, D. J. and Pasqualone, R. G. (1995), "ISO 9000 - A perspective on a global quality standard", *IEEE Transactions on Industry Applications*, Vol. 31 No. 1, pp. 61-67.
- Chantramonklasri, N. (1997), "The role of science and technology in Thailand's industrial sector", in Yuthavong, Y. and Wojcik, A. M. (Eds.), *Science and technology in Thailand: Lessons from a developing economy*, National Science and Technology Development Agency, Bangkok, pp. 31-43.
- Chen, W.-H. (1997), "The human side of Total Quality Management in Taiwan, leadership and human resources management", *International Journal of Quality & Reliability Management*, Vol. 14 No. 1, pp. 24-45.
- Chen, W.-H. and Lu, R. S. Y. (1998), "A Chinese approach to quality transformation", *International Journal of Quality & Reliability Management*, Vol. 15 No. 1, pp. 72-84.
- Chin, K.-S. (1996), "Quality management towards 2000: Hong Kong's perspective", *Proceedings of ASQC's 50th Annual Quality Congress*, ASQC,
-



---

Chicago, Illinois, 13-15 May 1996, pp. 338-341.

Chiu, R. K. (1998), "Involvement in a TQM program: Problem in Chinese firms in Hong Kong", *Proceedings of The 3rd International conference on ISO 9000 and TQM*, Hong Kong Baptist University, Hong Kong, 14-16 April 1998, pp. 376-381.

Chorn, N. H. (1991), "Total quality management: panacea or pitfall?", *International Journal of Physical Distribution & Logistic Management*, Vol. 21 No. 8, pp. 31-35.

Corbett, L. M., Jr., E. E. A., Harrison, N. J., Lee, T. S., RHO, B.-H. and Samson, D. (1998), "A study of quality management practices and performance in Asia and the South Pacific", *International Journal of Production Research*, Vol. 36 No. 9, pp. 2597-2607.

Crosby, P. B. (1980), *Quality is Free*, McGraw - Hill, New York.

Crosby, P. B. (1984), *Quality without tears*, McGraw-Hill, New York.

Crowe, T. J., Noble, J. S. and Machimada, J. S. (1998), "Multi - attribute analysis of ISO 9000 registration using AHP", *International Journal of Quality & Reliability Management*, Vol. 15 No. 2, pp. 205-222.

Crowther, J. (1995), *Oxford advanced learner's dictionary of current English*, 5th edition, Oxford University Press, Oxford.

Czuchry, A. J., Hyder, C., Yasin, M. and Mixon, D. (1997), "A systematic approach to improving quality: a framework and a field study", *International Journal of Quality & Reliability Management*, Vol. 14 No. 9, pp. 876-898.

Dale, B. G. and Plunkett, J. J. (1990), *Managing quality*, Philip Allan, New York.

Dale, B. G., Lascelles, D. M. and Plunkett, J. J. (1990), "The process of total quality management", in Dale, B. G. and Plunkett, J. J. (Eds.), *Managing quality*, Philip Allan, New York, pp. 3-18.

Dedhia, N. S. (1996), "Does ISO 9000 recognize inspection?", *Proceedings of ASQC's 50th Annual Quality Congress*, ASQC, Chicago, Illinois, 13-15 May 1996, pp. 575-579.

Deming, E. W. (1986), *Out of crisis*, Cambridge University Press, Cambridge.

Deming, W. E. (1993), *The New Economics for Industry, Government, Education*, the Massachusetts Institute of Technology, Cambridge, MA.

Dotchin, J. A. and Oakland, J. S. (1992), "Theories and concepts in total quality management", *Total Quality Management*, Vol. 3 No. 2, pp. 133-145.

---

- 
- DTI (1991), *Managing in the '90s: The quality gurus*, Department of Trade and Industry, London.
- Easterby-Smith, M., Thorpe, R. and Lowe, A. (1991), *Management Research: An Introduction*, Sage Publication, London.
- EFQM (1992), *Total quality management: The European Model for Self-appraisal*, EFQM, Eindhoven, Netherlands.
- Fabien, M. J. (1993), "Practical approaches to ISO 9000 certification for rubber & plastics processors", *Proceedings of IEEE Conference Record of Annual Conference of Electrical Engineering Problem in the Rubber and Plastics Industries*, IEEE, Piscataway, NJ, USA, Ohio, USA, 27-28 April 1993, pp. 24-45.
- Farquhar, C. R. (1991), "Total Quality Management: a competitive imperative for the 90s", *Optimum*, Vol. 21 No. 4, pp. 30-39.
- Feigenbaum, A. V. (1991), *Total quality control*, 40th Anniversary edition, McGraw-Hill, New York.
- Flood, R. L. (1993), *Beyond TQM*, John Wiley & Sons, Chichester.
- Flynn, B. B., Sakakibara, S., Schroeder, R. G., Bates, K. A. and Flynn, E. J. (1990), "Empirical research methods in operations management", *Journal of Operations Management*, Vol. 9 No. 2, pp. 250-284.
- French, G. and Eltringham, D. (1995), "Experiences of introducing ISO 9000 and total quality management in UK shipbuilding and repairing", *Journal of Ship Production*, Vol. 11 No. 3, pp. 196-202.
- Garvin, D. A. (1988), *Managing quality: The strategic and competitive edge*, The Free Press, New York.
- Gill, J. and Johnson, P. (1997), *Research Methods for Managers*, 2nd edition, Paul Chapman Publishing Ltd, London.
- Goult, R. (1995), "ISO 9000 - No silver bullet?", *Quality World*, Vol. 21 No. 3, pp. 164-166.
- Grenville, R. and Turnbull, T. (1995), "A global company's perspectives on ISO 9000", *Standardization News*, Vol. 32 No. 6, pp. 26-29.
- Gummesson, E. (1991), *Qualitative Methods in Management Research*, Revised edition, Sage Publications, London.
- Han, F. (1998), "The development and characteristics of China ISO 9000 quality system certification", *Proceedings of The 3rd International Conference*
-



- 
- on *ISO 9000 and Total Quality Management*, Hong Kong Baptist University, Hong Kong, 14-16 April 1998, pp. 382-385.
- Harrington, H. J. (1996), "National traits in TQM principles and practices", *The TQM Magazine*, Vol. 8 No. 4, pp. 49-54.
- Harrington, H. J. and Mathers, D. D. (1997), *ISO 9000 and Beyond*, McGraw-Hill, New York.
- Hassan, M. E. M. (1996), "Quality management in Malaysian organizations: The relevance of values to improvement process", *Ph.D. Thesis*, Newcastle University.
- Hayden, W. M. (1996), "Integrating TQM & ISO 9000", *Proceedings of ASQC's 50th Annual Quality Congress*, ASQC, Chicago, Illinois, 13-15 May 1996, pp. 183-191.
- Heisey, S. W. (1994), "Achieving ISO 9002 registration at Kalas engineered cable products division (ECPD) - one company's experience", *Proceedings of the Annual convention of the Wire Association International*, Wire Associations Int. Inc., Guilford, CT, pp. 245-248.
- Hind, M. (1996), "Are the cultures required to attain ISO 9000 can total quality management mutually exclusive?", *The TQM Magazine*, Vol. 4 No. 2, pp. 25-29.
- Hiroiyuki, H., Tassio, T., Tomo, S., Yutaka, N. and Chiro, S. (1992), *5-S Technique*, S. Asia Press, Bangkok. (in Thai)
- HKQAA (1999), "ISO 9000 quality management system", April 1999, *Internet*; <http://www.hkqaa.com.hk/iso9000.htm>
- Ho, S. K. (1995), *TQM: An integrated approach*, Kogan Page, London.
- Hofstede, G. H., Neuijen, B., Ohayv, D. D. and Sanders, G. (1990), "Measuring organizational cultures: a qualitative and quantitative study across twenty cases", *Administrative Science Quarterly*, Vol. 35, pp. 286-316.
- Hong, L. K. (1996), "Standards and conformance in Singapore", *Proceedings of The first APEC Conference on Standards and Conformance*, Manila, Philippines, 9-11 October 1996.
- Huang, F. (1998), "Integraing ISO 9000 with TQM spirits: a survey", *Industrial Management and Data Systems*, Vol. 98 No. 7-8, pp. 373-374.
- Hurd, J. W. L. (1992), "Quality in the Asia Pacific", *International Journal of Quality & Reliability Management*, Vol. 9 No. 3, pp. 14-20.
- Huyink, D. S. (1994), "ISO 9000 implementation: the human side addressing
-

---

critical success factors of an ISO 9000 registration project within a corporate culture", *Proceedings of The ASQC 48th Annual Quality Congress*, ASQC, Milwaukee, WI, USA, Las Vegas, NV, USA, pp. 651-658.

Idris, M. A., McEwan, W. and Belavendram, N. (1996), "The adoption of ISO 9000 and Total Quality Management in Malaysia", *The TQM Magazine*, Vol. 8 No. 5, pp. 65-68.

Idris, M. A., McEwan, W. and Belavendram, N. (1997), "A TQM implementation model for small and medium sized manufacturing firms", *Proceedings of The 2nd International Conference on ISO 9000 and Total Quality Management*, Luton Business School, the Luton Business School, University of Luton, UK, 2-4 April 1997, pp. 399-404.

IMD (1999), "The world competitiveness yearbook 1999", May 1999, *Internet*; <http://www.imd.ch/wcy/index.html>

IQA (1995), "ISO 9000 The Future - the Institute of Quality Assurance's proposals for ISO 9000 series Phase II revision", *Quality World*, Vol. 21 No. 5, pp. 332-337.

Ishikawa, K. (1988), *Introduction to quality control*, 3rd edition, 3A Corporation, Tokyo.

ISO (1986), *ISO 8402: Quality Vocabulary*, International Organisation for Standardization, Geneva.

ISO (1997), *The ISO Survey of ISO 9000 and ISO 14000 Certificates - Seventh Cycle*, International Organization for Standardization, Geneva.

ISO (1999), "ISO 9000 revisions: draft International Standards expected in 4Q 1999", March, *Internet*; <Http://www.iso.ch/press/cd2e.htm>

Ivancevich, J. M., Lorenzi, P., Skinner, S. J. and Crosby, P. B. (1994), *Management: quality and competitiveness*, IRWIN, Burr Ridge, Illinois.

Izumi, H. and Whitfield, R. C. (1997), "Hong Kong students' perceptions of structures for total quality management", *International Journal of Quality & Reliability Management*, Vol. 14 No. 7, pp. 711-731.

Janchai, A., Watanasin, P., Jivamitr, S., Tanlamai, A., Chamnanwech, S., Durongwatana, S., Kaetawandee, P. and Leewatankij, W. (1997), *Thai industry vision 2020*, The Federation of Thai Industry, Bangkok. (in Thai)

Jeng, Y. C. (1998), "Performance evaluation of ISO 9000 registered companies in Taiwan", *The TQM Magazine*, Vol. 10 No. 2, pp. 132-138.

Jones, S. (1985), "The analysis of depth interviews", in Walker, R. (Ed.), *Applied Qualitative Research*, Gower, Aldershot, pp. 56-70.

---



- 
- Jones, S. (1987), "Choosing action research: A rationale", in Mangham, I. L. (Ed.), *Organization analysis and development: A social construction of organizational behaviour*, John Wiley & Sons, Chichester, pp. 23-45.
- Jones, R., Arndt, G. and Kustin, R. (1997), "ISO 9000 among Australian companies: impact of time and reasons for seeking certification on perceptions of benefits received", *International Journal of Quality & Reliability Management*, Vol. 14 No. 7, pp. 650-660.
- Juran, J. M. (1988), *Juran's Quality Control Handbook*, 4th edition, McGraw-Hill, New York.
- Juran, J. M. (1993), "Made in U.S.A. : A renaissance in quality", *Harvard Business Review*, Vol. 71 No. 4, pp. 42-50.
- Juran, J. M. and Gryna, F. M. (1993), *Quality planning and analysis*, 3rd edition, McGraw-Hill, New York.
- Kang, I. K. (1996), "The status of standards conformance in Korean industry - the experience of LG Electronics", *Proceedings of The first APEC Conference on Standards and conformance*, Manila, Philippines, 9-11 October 1996.
- Kang, C. W. (1996), "The current status of quality management in Korea", *Proceedings of ASQC's 50th Annual Quality Congress*, ASQC, Chicago, Illinois, 13-15 May 1996, pp. 450-456.
- Kano, N. (1993), "A perspective on quality activities in American firms", *California Management Review*, Vol. 35 No. 3, pp. 12-31.
- Kaye, M. and Dyason, M. (1997), "East meets West in the quality management experience", *Quality World*, Vol. 23 No. 8, pp. 648-652.
- Kehoe, D. F. (1996a), *The Fundamental of Quality Management*, Chapman & Hall, London.
- Kehoe, D. (1996b), "The parametric modelling of the quality development within manufacturing organisations", *Ph.D. Thesis*, University of Liverpool.
- Kekale, T. and Kekale, J. (1995), "A mismatch of cultures, a pitfall of implementing a total quality approach", *International Journal of Quality & Reliability Management*, Vol. 12 No. 9, pp. 210-220.
- Kolarik, W. J. (1995), *Creating Quality - Concepts, Systems, Strategies, and Tools*, McGraw-Hill, New York.
- Kondo, Y. (1995), *Companywide Quality Control*, 3A Corporation, Tokyo.
- Kondo, Y. (1997), "Quality as a source of empowerment", *TQM Magazine*,
-

---

Vol. 9 No. 5, pp. 357-363.

Krasachol, L., Willey, P. C. T. and Tannock, J. D. T. (1998), "The progress of quality management in Thailand", *The TQM Magazine*, Vol. 10 No. 1, pp. 40-44.

Kume, H. (1993), "Japanese point of view on the ISO 9000 standards", *Quality and Reliability Engineering International*, Vol. 9 No. 2, pp. 85-87.

Lascelles, D. and Dale, B. (1993), *The road to quality*, IFS, Bedford.

Lee, T. Y. (1993), "Total quality management in Hong Kong industry and its subsidiaries in china", *Quality and Reliability Engineering International*, Vol. 9 No. 3, pp. 179-183.

Lee, T. Y. (1995), "The experience of implementing ISO 9000 in Hong Kong", *Asia Pacific Journal of Quality Management*, Vol. 4 No. 4, pp. 6-16.

Lee, T. Y. (1998), "The development of ISO 9000 certification and the future of quality management - a survey of certified firms in Hong Kong", *International Journal of Quality & Reliability Management*, Vol. 15 No. 2, pp. 162-177.

Lin, C. (1998), "Effect of organizational climate on quality management practice - a empirical study on small and medium-sized manufacturing companies in Taiwan", *Proceedings of Annual Meeting of the Decision Sciences Institute*, Decis Sci Inst., Atlanta, GA, USA, Atlanta, GA, USA, 22-25 November 1997, pp. 1082-1084.

Lisiecka, K. (1998), "ISO 9000 standards and TQM strategy - business improvement tools for Polish companies", *Proceedings of The 3rd International conference on ISO 9000 and Total Quality Management*, Hong Kong Baptist University, Hong Kong, 14-16 April 1998, pp. 35-40.

Logothetis, N. (1992), *Managing for Total Quality: from Deming to Taguchi and SPC*, Prentice Hall International, Hempstead.

Longbottom, L. (1995), "Total quality management in financial services: An empirical study of performance, strategy and best practice", *Ph.D. Thesis*, University of Bradford.

Lueprasitskul, V. (1997), *TQM Living Handbook*, BPR and TQM Consultant, Bangkok. (in Thai)

Lupear, W. J. (1993), "Managing ISO 9000 implementation", *Journal of Engineering for Gas Turbines and Power*, Vol. 115 No. 4, pp. 793-800.

Mallak, L. A., Bringelson, L. S. and Lyth, D. M. (1997), "A cultural study of ISO 9000 certification", *International Journal of Quality & Reliability Management*, Vol. 14 No. 4, pp. 328-348.

---



- 
- Manarungsan, S. (1989), *Economic Development of Thailand, 1850-1950*, Chulalongkorn University, Bangkok.
- Mann, R. S. (1992), "The development of a framework to assist in the implementation of total quality management", *Ph.D. Thesis*, University of Liverpool.
- Mann, R. and Kehoe, D. (1995), "Factors affecting the implementation and success of TQM", *International Journal of Quality & Reliability Management*, Vol. 12 No. 1, pp. 11-23.
- McLachlan, V. N. (1996), "Perspectives in praise of ISO 9000", *The TQM Magazine*, Vol. 8 No. 3, pp. 21-23.
- McTeer, M. M. and Dale, B. G. (1996), "The attitudes of small companies to the ISO 9000 series", *Journal of Engineering Manufacture*, Vol. 210, pp. 397-403.
- Merrill, P. (1996), "Category III. Process quality improvement; the 'hidden' communication systems in an ISO 9000 quality system", *Proceedings of ASQC's 50th Annual Quality Congress*, ASQC, Chicago, Illinois, 13-15 May 1996, pp. 468-478.
- Mohd Zain, Z. M. (1993), "A proposal for the measurement of quality position in the United Kingdom manufacturing industries", *Ph.D. Thesis*, University of Liverpool.
- Motwani, J., Kumar, A. and Cheng, C. H. (1996), "A roadmap to implementing ISO 9000", *International Journal of Quality & Reliability Management*, Vol. 13 No. 1, pp. 72-83.
- Najmi, M. (1998), "An integrated framework for post-ISO9000 quality development within manufacturing organisations", *Ph.D. Thesis*, University of Liverpool.
- Nananukul, S., Ratanakorn, C., Onsmas, P., Jantraporn, S., Suthapakti, P., Intrapichet, K. and Nak-arthit, P. (1986a), *TOC-Total Quality Control*, Pumbhandit, Bangkok. (in Thai)
- Nananukul, S., Ratanakorn, C., Onsmas, P., Jantraporn, S., Suthapakti, P., Intrapichet, K. and Nak-arthit, P. (1986b), *QCC- Quality Control Circle*, Pumbhandit, Bangkok. (in Thai)
- NESDB (1996), *The eighth national economic and social development plan (1997-2001)*, National Economic and Social Development Board, Office of The Prime Minister, Bangkok.
- Ng, H. (1998), "ISO 9000: Yes or no?", *Proceedings of The 3rd International*
-

- 
- Conference on ISO 9000 and Total Quality Management*, Hong Kong Baptist University, Hong Kong, 14-16 April 1998, pp. 84-88.
- NIST (1999a), "1999 Award Criteria Malcolm Baldrige National Quality Award", April 1999, *Internet*; [http://www.quality.nist.gov/docs/99\\_crit/99criter.pdf](http://www.quality.nist.gov/docs/99_crit/99criter.pdf)
- NIST (1999b), "1998 Fact sheet, Malcolm Baldrige National Quality Award", June 1999, *Internet*; <http://www.quality.nist.gov/98fact-b.htm>
- NIST (1999c), "Building on Baldrige: American quality for the 21st century", June 1999, *Internet*; <http://www.quality.nist.gov/qulbob.htm>
- NSTDA (1996), *Directory of ISO 9000 certified companies in Thailand*, National Science and Technology Development Agency, Bangkok.
- NSTDA (1999), *Directory of ISO 9000 certified Companies in Thailand*, National Science and Technology Development Agency, Bangkok.
- Oakland, J. S. (1993), *Total Quality Management*, 2nd edition, Butterworth-Heinemann, Oxford.
- Oliver, N. and Wilkinson, B. (1992), *The Japanization of British Industry*, 2nd edition, Blackwell Publishers, Oxford.
- Owen, B., Cothran, T. and Malkovich, P. (1994), *Achieving ISO 9000 registration*, SPC Press, Tennessee.
- Peach, R. W. (1996), "Putting the ISO 9000 family of standards to use", *Proceedings of ASQC's 50th Annual Quality Congress*, ASQC, Chicago, Illinois, 13-15 May 1996, pp. 351-355.
- Peters, T. J. and Waterman, R. H. (1982), *In search of excellence*, Harper and Row, New York.
- Powell, T. C. (1995), "Total quality management as competitive advantage: a review and empirical study", *Strategic Management Journal*, Vol. 16 , pp. 15-37.
- Prasad, S., Tata, J. and Thorn, R. (1996), "Benchmarking Maquiladora Operations Relatives to the USA", *International Journal of Quality & Reliability Management*, Vol. 13 No. 9, pp. 8-18.
- PSB (1999), "The PBS ISO 9000 certification scheme", April, *Internet*; <http://www.psbcertdir.gov.sg/PSB/index.htm>
- Pulat, B. M. (1994), "Total quality management: A framework for application in manufacturing", *The TQM Magazine*, Vol. 6 No. 4, pp. 44-49.
- Quazi, H. A. and Padibjo, S. R. (1998), "A journey towards TQM through ISO 9000 certification - a study of small and medium enterprises in Singapore",
-



---

*International Journal of Quality & Reliability Management*, Vol. 5 No. 5, pp. 489-509.

Quazi, H., Lim, B.-C. and Lee, P.-M. (1998), "Use of non-financial indicators for customer satisfaction measurement: an empirical study in Singapore", *Proceedings of The 3rd International conference on ISO 9000 and TQM*, Hong Kong Baptist University, Hong Kong, 14-16 April 1998, pp. 196-202.

Reavill, L. R. P. (1998), "What is the future of TQM development?", *Proceedings of The 3rd International Conference on ISO 9000 and TQM*, Hong Kong Baptist University, Hong Kong, 14-16 April 1998, pp. 47-52.

Rohwer, J. (1995), *Asia Rising*, Nicholas Brealey, London.

Sandholm, L. (1988), "Quality in developing countries", in Juran, J. M. and Gryna, F. M. (Eds.), *Juran's Quality Control Handbook*, McGraw-Hill, New York, pp. 35B.1-26.

Sasananan, M. (1999), "Development of a framework for the transfer of quality management to Thai industry", *Ph.D. Thesis*, University of Nottingham.

Sayle, A. (1998), "Can quality calm the roar of the stricken Asian tiger?", *Quality world*, April 1998, pp. 38-40.

Schlossstein, S. (1991), *Asia's new little dragons: The dynamic emergence of Indonesia, Thailand, and Malaysia*, Contemporary Book, Chicago, Illinois.

Schonberger, R. (1982), *Japanese Manufacturing Techniques*, The Free Press, New York.

Schottmiller, J. C. (1996), "ISO 9000 and quality costs", *Proceedings of ASQC's 50th Annual Quality Congress*, ASQC, Chicago, Illinois, 13-15 May 1996, pp. 194-199.

Seddon, J. (1997), *In pursuit of quality*, Oak Tree Press, London.

Sheehan, B. (1998), "International Competitiveness - Challenge for Thailand", *Rangsit Business Review*, Vol. 1 No. 1, pp. 85-93.

Simachokdee, V. (1998a), "TQM... How not to fail", *Rangsit Business Review*, Vol. 1 No. 1, pp. 80-84. (in Thai)

Simachokdee, V. (1998b), *TQM: Handbook for organisation 2000*, TPA Publishing, Bangkok. (in Thai)

SIRIM (1999), "Directory service online", April, *Internet*; <http://www.sirim.my:8080/ifmx-bin/wcdrvr.exe?MIval=ods>

- 
- Sripaipan, C. (1994), *A Proposed Framework of the Thai Industrial Standards System*, Thailand Development Research Institute Foundation, Bangkok.
- Srivastav, A. K. (1994), "ISO 9000 and its impact on organizations", *IETE Technical Review*, Vol. 11 No. 4, pp. 255-260.
- STAMEQ (1999a), "Vietnam quality award", June 1999, *Internet*; [http://home.vnn.vn/tcvn/award\\_en.htm](http://home.vnn.vn/tcvn/award_en.htm)
- STAMEQ (1999b), "System of certifications", June 1999, *Internet*; [http://www.vnn.vn/tcvn/sys\\_en.htm](http://www.vnn.vn/tcvn/sys_en.htm)
- Strauss, A. and Corbin, J. (1990), *Basics of Qualitative Research: Grounded Theory Procedures and Techniques*, Sage Publications, London.
- Struebing, L. (1996), "9000 standards", *Quality Progress*, Vol. 29 No. 1, pp. 23-28.
- Tabucanon, M. T. (1993), "Thailand's manufacturing sector: issues on development, technology, and management", *Journal of Manufacturing Systems*, Vol. 12 No. 3, pp. 199-203.
- Tambunlertchai, S. (1993), "Manufacturing", in Warr, P. G. (Ed.), *The Thai economy transition*, Cambridge University Press, Cambridge, pp. 118-150.
- Taylor, F. W. (1911), *The Principles of Scientific Management*, Harper and Row, New York.
- Taylor, W. A. (1995), "Organizational differences in ISO 9000 implementation practices", *International Journal of Quality & Reliability Management*, Vol. 12 No. 7, pp. 10-27.
- TDRI (1998), *Structural adjustment for competitiveness and sustainability of the Thai economy*, Thailand Development Research Institute, Bangkok.
- Telarc (1996), *Building Better Business*, Telarc, Auckland, New Zealand.
- Terziovski, M., Sohal, A. and Samson, D. (1996), "Best practice implementation of total quality management: Multiple cross-case analysis of manufacturing and service organizations", *Total Quality Management Journal*, Vol. 7 No. 5, pp. 459-481.
- The Economist (1997), "South-East Asia's learning difficulties", *The Economist*, 16th August 1997, pp. 21-22.
- Thiagarajan, T. (1996), "An empirical study of TQM in Malaysia: A proposed framework of generic application", *Ph.D. Thesis*, University of Bradford.
- Toyosawa, T. (1988), *Suggestion Systems*, T.P. Print, Bangkok. (in Thai)
-



- 
- TPI (1998), *Evaluation Study on the Effects of ISO 9000 Quality Management Systems to Thai Enterprises*, Thailand Productivity Institute, Bangkok.
- Tsiakals, J. and Cianfrani, C. (1996), "ISO 9001 in the next millennium: the future revision of ISO 9001, ISO 9002, and ISO 9003", *Proceedings of ASQC's 50th Annual Quality Congress*, ASQC, Chicago, Illinois, 13-15 May 1996, pp. 356-363.
- Tsiotras, G. and Gotzamani, K. (1996), "ISO 9000 as an entry key to TQM: the case of Greek industry", *International Journal of Quality & Reliability Management*, Vol. 13 No. 4, pp. 64-76.
- Voss, C. A. (1987), *Just-in-time manufacturing*, IFS Publication, London.
- Wallace, M. J. and Murphy, E. (1993), "TQM: an overview of Ireland's experience", *Proceedings of First Newcastle International Conference on Quality and its applications*, September 1993, pp. 93-100.
- Warr, P. G. (1993), "The Thai economy", in Warr, P. G. (Ed.), *The Thai economy transition*, Cambridge University Press, Cambridge, pp. 1-80.
- Wenmoth, B. A. and Dobbin, D. J. (1994), "Experience with implementing ISO 9000", *Asia Pacific Journal of Quality Management*, Vol. 3 No. 3, pp. 9-27.
- Westbrook, R. (1995), "Organizing for total quality: case research from Japan", *International Journal of Quality & Reliability Management*, Vol. 12 No. 4, pp. 8-25.
- Whittle, S., Smith, S., Tranfield, D. and Foster, M. (1991), "Implementation total quality: Erecting tents or building palaces", *Proceedings of The 6th International Conference of OMA (UK)*.
- Whittle, S., Smith, S., Tranfield, D. and Foster, M. (1992), "Total quality and change management: Integrating approaches for organisation design", *Proceedings of The Institute of Electrical Engineers Third International Conference*, York, July 1992.
- Whittle, S., Smith, S., Tranfield, D. and Foster, M. (1993), *TQM2: A prototype guide for consultants*, Report No. 17, Change Management Research Centre, Sheffield Business School, Sheffield Hallam University, Sheffield.
- Yaacov, G. B. (1995), "Reap the rewards of quality with ISO 9000", *IEEE Computer Applications in Power*, Vol. 8 No. 4, pp. 26-30.
- Yin, R. K. (1994), *Case Study Research: Design and Methods*, revised edition, Sage Publication, London.
-

Yuanzhang, L. (1994), "TQM in the socialist market economy of China", *Asia Pacific Journal of Quality Management*, Vol. 3 No. 3, pp. 36-44.

Yuthavong, Y. (1997), "Science and Technology in Developing Countries", in Yuthavong, Y. and Wojcik, A. M. (Eds.), *Science and technology in Thailand: lessons from a developing economy*, National Science and Technology Development Agency, Bangkok, pp. 1-16.



## **APPENDICES**

### **The survey project**

Appendix 1 Survey questionnaire

### **The ISO 9000 research project**

Appendix 2 Consulting plan

Appendix 3 Structured interview

Appendix 4 Cognitive maps of five companies

Appendix 5 An example of baseline evaluation report

### **The TQM research project**

Appendix 6 Proposal for a study of TQM in Thai industry

Appendix 7 Core phrases from TQM interviews

Appendix 8 Permission letters from collaborating companies

### **The TFOSS research project**

Appendix 9 Summary report on responses of commentators

Appendix 10 Thai Foundation Quality System Standard

## **Appendix 1: Survey questionnaire**

- **Covered letter signed by the NSTDA director**
- **Covered letter signed by the researcher**
- **Questionnaire**



**TEXT BOUND INTO  
THE SPINE**

ที่ วว 5201/ 4389

2 สิงหาคม 2539

เรื่อง ขอความร่วมมือตอบแบบสอบถาม

เรียน กรรมการผู้จัดการ

ด้วยสำนักงานพัฒนาวิทยาศาสตร์และเทคโนโลยีแห่งชาติ ซึ่งเป็นองค์การของรัฐ มีหน้าที่ในการพัฒนาวิทยาศาสตร์และเทคโนโลยี เพื่อพัฒนาอุตสาหกรรมของประเทศ โดยงานมาตรฐาน การทดสอบ และการควบคุมคุณภาพ ดำเนินการสนับสนุนให้อุตสาหกรรมมีพื้นฐานระบบคุณภาพที่ได้มาตรฐานในระดับสากล นางลดาวัลย์ กระแสร์ชล เป็นนักวิชาการ งานมาตรฐาน การทดสอบ และการควบคุมคุณภาพ รับผิดชอบงานในด้านดังกล่าว กำลังทำวิทยานิพนธ์ระดับปริญญาเอก สาขา Quality Management ที่ University of Nottingham ณ ประเทศอังกฤษ ได้ออกแบบสอบถามเกี่ยวกับระบบคุณภาพ ISO 9000 และ TQM เพื่อสำรวจการประยุกต์ใช้ระบบคุณภาพดังกล่าวของอุตสาหกรรมในประเทศไทย

สำนักงานฯ พิจารณาแล้วเห็นว่า วิทยานิพนธ์ดังกล่าวจะเป็นประโยชน์ต่ออุตสาหกรรมของประเทศไทย และการดำเนินงานสนับสนุนอุตสาหกรรมของสำนักงานฯ จึงใคร่ขอความอนุเคราะห์จากท่านโปรดให้ความร่วมมือในการตอบแบบสอบถามจักขอบคุณยิ่ง

ขอแสดงความนับถือ



(นายยงยุทธ ยุทธวงศ์)

ผู้อำนวยการ

ส่วนงานกลาง

ฝ่ายวิจัย พัฒนาและวิศวกรรมฯ

โทร. 6448150-99 ต่อ 401



**Translation of  
the covered letter of questionnaire signed by the NSTDA Director**

2 August 1996

Subject: Survey Questionnaire

Dear Managing Director

(Name of a company)

The National Science and Technology Development Agency (NSTDA) is a government agency for the purpose of developing the science and technology system of the country in the support of the national economic development. One of the main responsibilities of NSTDA is to provide various forms of industrial development supports including standards, testing and quality control to the private sector. Mrs. Ladawan Krasachol has been working in the Standards, Testing and Quality Control (STQC) section as a technical expert. She is currently studying PhD on quality management in the University of Nottingham, UK. Her research is concerning quality management in Thailand, particularly ISO 9000 series of quality systems standards and Total Quality Management (TQM). And she has designed a questionnaire in order to collect information about quality management in Thailand.

It has been considered that her research will be useful for Thai industry as well as NSTDA industrial supporting activities. I would be grateful if your company could participate in her research by responding to the questionnaire.

Sincerely Yours,

(Prof. Yongyuth Yuthavong)

NSTDA Director

---

2 สิงหาคม 2539

เรื่อง ขอความร่วมมือออกแบบสอบถามเกี่ยวกับระบบคุณภาพ ISO 9000 และ TQM สำหรับงานวิทยานิพนธ์

เรียน กรรมการผู้จัดการ

สิ่งที่ส่งมาด้วย แบบสอบถามเกี่ยวกับระบบคุณภาพ ISO 9000 และ TQM สำหรับงานวิทยานิพนธ์

เนื่องด้วยดิฉัน นางสาววัลย์ กระแสร์ชล นักวิชาการ งานมาตรฐาน การทดสอบ และการควบคุม  
คุณภาพ ฝ่ายวิจัย พัฒนา และวิศวกรรม และสร้างความสามารถของสถาบัน สำนักงานพัฒนาวิทยาศาสตร์และ  
เทคโนโลยีแห่งชาติ กำลังศึกษาระดับปริญญาเอก สาขา Quality Management ภาควิชา Manufacturing  
Engineering and Operation Management คณะวิศวกรรมศาสตร์ ที่ University of Nottingham ณ ประเทศ  
อังกฤษ โดยดำเนินการวิจัยเกี่ยวกับการประยุกต์ใช้ระบบคุณภาพในอุตสาหกรรมในประเทศไทย ในการวิจัย  
ดังกล่าว จำเป็นต้องได้รับข้อมูลที่ถูกต้องจากภาคอุตสาหกรรม เพื่อนำไปวิเคราะห์และเสนอแนะแนวทาง  
อันเป็นประโยชน์ต่ออุตสาหกรรมของประเทศ จึงขอความอนุเคราะห์ท่านโปรดออกแบบสอบถามตามสิ่งที่  
ส่งมาด้วย และดิฉันขอรับรองว่า ข้อมูลทั้งหมดที่ท่านกรอกในแบบสอบถาม จะได้รับการปกปิดเป็นความลับ  
ซึ่งในการนำเสนอผลการวิจัย จะเสนอเป็นภาพรวมจากการวิเคราะห์เท่านั้น

จึงเรียนมาเพื่อโปรดออกแบบสอบถาม และส่งกลับไปยังดิฉันด้วยขอ และแถมปีที่แนบมาด้วย  
จักเป็นพระคุณยิ่ง

ขอแสดงความนับถือ



(นางสาววัลย์ กระแสร์ชล)

นักวิชาการ

ส่วนงานกลาง

งานมาตรฐาน การทดสอบ และการควบคุมคุณภาพ

ฝ่ายวิจัย พัฒนาและวิศวกรรมฯ

โทร. 2487541-8,6425191-3

หมายเหตุ

โปรดกรุณาส่งแบบสอบถามคืน

ภายใน วันที่ 8 กันยายน 2539



**Translation of  
the covered letter of questionnaire signed by the researcher**

2 August 1996

Subject: Survey Questionnaire

Dear Managing Director

(Name of a company)

My name is Ladawan Krasachol and I work as a technical expert in the Standards, Testing and Quality Control (STQC) section of the National Science and Technology Development Agency (NSTDA). I am now pursuing PhD study in the Department of Manufacturing Engineering and Operations Management at the University of Nottingham, UK. My research is related to the development of quality management in Thai industry. In doing this research, I need the information from Thai companies. Therefore, I have designed a questionnaire in order to collect the data that will be analysed and the results from the research are expected to be useful to Thai industry. I confirm that the information provided by your company will remain strictly confidential.

I would appreciate your kind co-operation. After you fill in the questionnaire, please send it back to me in the provided stamped envelope.

Sincerely Yours,

(Mrs. Ladawan Krasachol)

Technical Expert

ISO 9000 AND TQM QUESTIONNAIRE  
แบบสอบถามเกี่ยวกับระบบคุณภาพ ISO 9000 และ TQM

INTRODUCTION บทนำ

There is no doubt that the ISO 9000 series of quality systems standards is well known and accepted internationally. Although the ISO standards are not mandatory for manufacturing companies, countries such as UK and USA have a large number of companies certified to ISO 9001/9002 standards. The ISO 9000 series has become acceptable world-wide because most certified companies have found significant benefits from ISO 9000 certification. It has been claimed that the achievement of ISO 9000 certification enhanced not only external competitive advantages and a good image of the certified companies themselves, but also internal improvement. However, there are criticisms concerning the ISO 9000 series and conflicting reports on the results of ISO 9000 implementation. TQM (Total Quality Management) is another quality system which is used world-wide. Some companies implemented TQM first and used ISO 9000 as one of their TQM tools. Some implemented ISO 9000 as the first step of TQM.

In the world market, Thai industry is facing global competition. Implementation of ISO 9000 series of quality systems has been regarded as an essential mean to help Thai industry to compete globally although it would require considerable effort and expenses. The aim of this research is to investigate the advantages and drawbacks of ISO 9000 implementation as well as the quality background and awareness in Thai industry. It would be much appreciated if you could complete the enclosed questionnaire and send it back in the envelop enclosed. Your kind co-operation will be extremely useful for this research. If you would like to receive the summary of the results, please indicate on questionnaire.

ในปัจจุบันมาตรฐานระบบคุณภาพ ISO 9000 เป็นที่รู้จักและยอมรับในระดับสากล แม้ว่า ISO 9000 ไม่ได้เป็นข้อบังคับสำหรับผู้ผลิตในอุตสาหกรรมทั้งหลาย แต่ในประเทศอย่างเช่น อังกฤษ และ สหรัฐอเมริกามีจำนวนบริษัทที่ได้รับการรับรองระบบคุณภาพตามมาตรฐาน ISO 9001/9002 เป็นจำนวนมาก บริษัทที่ได้รับการรับรองพบว่าได้รับประโยชน์เป็นอย่างมากจาก ISO 9000 บริษัทเหล่านี้กล่าวว่า ISO 9000 ไม่เพียงก่อให้เกิดประโยชน์ต่อภาพลักษณ์ของบริษัท และเป็นข้อได้เปรียบในการแข่งขันในตลาดโลกเท่านั้น แต่ยังก่อให้เกิดการปรับปรุงภายในด้วย แต่อย่างไรก็ตาม ยังมีข้อถกเถียง และคำวิจารณ์เกี่ยวกับผลที่เกิดจากการนำระบบคุณภาพ ISO 9000 ไปประยุกต์ใช้ การจัดการคุณภาพแบบเบ็ดเสร็จ หรือ TQM เป็นอีกหนึ่งแนวคิดซึ่งนำไปใช้กันทั่วโลก บางบริษัทเริ่มต้นด้วย TQM และใช้ ISO 9000 เป็นเครื่องมือส่วนหนึ่ง บางบริษัทใช้ ISO 9000 เป็นก้าวแรกสู่ TQM



อุตสาหกรรมของไทยกำลังจะเผชิญการแข่งขันในตลาดโลก ISO 9000 เป็นสิ่งจำเป็นที่จะช่วยให้ยืนหยัดได้แม้ว่าจะต้องลงทุน และลงแรงอย่างมาก วัตถุประสงค์ของงานวิจัยนี้ต้องการศึกษาพื้นฐาน และแนวคิดทางด้านคุณภาพของอุตสาหกรรมไทย รวมทั้งข้อได้เปรียบและผลเสียที่เกิดจากการนำระบบคุณภาพ ISO 9000 และ TQM ไปใช้ในองค์กร ดิฉันขอขอบพระคุณอย่างสูงในความร่วมมือในการตอบแบบสอบถามที่แนบมานี้ คำตอบและข้อคิดเห็นของท่านจะเป็นประโยชน์อย่างยิ่งต่องานวิจัยนี้ และหากท่านต้องการได้รับสรุปผลของงานวิจัยครั้งนี้ โปรดระบุในแบบสอบถาม

**SECTION I COMPANY PROFILE ส่วนที่ 1 รายละเอียดของบริษัท**

1. Name ชื่อ .....
2. Job Title ตำแหน่ง .....
3. Company Name ชื่อบริษัท .....
4. Company Address ที่อยู่ .....
5. Telephone Number โทรศัพท์ .....
6. Fax Number โทรสาร .....
7. Email account .....
8. Is the company 100% Thai owned ? บริษัทไทย 100 %
  - a) yes ใช่
  - b) no - please give detail .....  
ไม่ใช่ - โปรดให้รายละเอียด
9. Number of employees (approximately) จำนวนพนักงานโดยประมาณ ..... คน
10. Capital investment ทุนจดทะเบียน
  - a) less than 50 Mbaht น้อยกว่า 50 ล้านบาท
  - b) 50 Mbaht - 100 Mbaht ระหว่าง 50-100 ล้านบาท
  - c) more than 100 Mbaht มากกว่า 100 ล้านบาท
11. Main area of manufacturing สายการผลิตหลัก
  - a) Textiles สิ่งทอ
  - b) Food อาหาร
  - c) Metal Manufacturing โลหะ
  - d) Chemical Industry เคมี
  - e) Mechanical Engineering เครื่องกล
  - f) Electrical & Electronic ไฟฟ้า และอิเล็กทรอนิกส์
  - g) Motor Vehicles ยานยนต์
  - h) Rubber & Plastics ผลิตภัณฑ์ยาง และพลาสติก

- i) Other - please specify อื่นๆ โปรดระบุ .....
- 12. The percentage of total sales which is exported. เปอร์เซ็นต์การส่งออกของผลิตภัณฑ์ที่ผลิตได้
  - a) 0 %
  - b) 1 - 25 %
  - c) 26 - 50 %
  - d) 51 - 75 %
  - e) 76 - 100 %
- 13. Level of turnover achieved in the last financial year รายได้ของบริษัทในปีที่ผ่านมา
  - a) less than 10 Mbaht น้อยกว่า 10 ล้านบาท
  - b) 10 Mbaht - 50 Mbaht 10-50 ล้านบาท
  - c) 50 Mbaht - 100 Mbaht 50-100 ล้านบาท
  - d) over 100 Mbaht มากกว่า 100 ล้านบาท

**SECTION II ISO 9000 DETAILS ส่วนที่ 2 รายละเอียดเกี่ยวกับการใช้ ISO 9000**

- 14. Are you interested in being certified as having an ISO 9000 approved quality system?  
 ท่านมีความสนใจในการขอการรับรองระบบคุณภาพ ISO 9000 หรือไม่
  - a) yes ต้องการ
  - b) no because ไม่ต้องการ เพราะ .....

.....

(if the answer is no, please skip item 15 to 39 and go to item 40, ถ้าตอบไม่ต้องการ กรุณาข้ามข้อ 15-39 ไปตอบข้อ 40)
- 15. Do you want the whole of your company to be certified? ท่านต้องการได้รับการรับรองทั้งบริษัท
  - a) yes ใช่
  - b) no ไม่ใช่

if the answer is no please skip item 16 and go to item 17 ถ้าตอบไม่ใช่ กรุณาข้ามข้อ 16 ไปตอบข้อ 17
- 16. Profile of the certified area/area to be certified. รายละเอียดส่วนที่ขอการรับรอง
  - Number of employees จำนวนพนักงาน .....
  - Scope of certification ขอบข่ายของการรับรอง .....
  - .....



17. Why do you want to implement ISO 9000 quality system? ทำไมท่านจึงต้องการใช้ระบบ ISO 9000

Please prioritise by using the numbers 1, 2, 3,...6, where the lowest number corresponds to the highest priority. โปรดเรียงลำดับความสำคัญโดยใช้เลข 1 - 6 โดย 1 = สำคัญที่สุด 6 = สำคัญน้อยที่สุด

- a) customer preference ลูกค้าต้องการ (ไม่ใช่ไม่เลิกธุรกิจ) .....
- b) essential to do business with customer จำเป็นต้องใช้ (ไม่ใช่ลูกค้ายกเลิกธุรกิจ) .....
- c) competitiveness in global market แข่งขันได้ในตลาดโลก .....
- d) good starting step for TQM จุดเริ่มต้นที่ดีสำหรับ TQM .....
- e) internal improvement ปรับปรุงระบบภายในของบริษัท .....
- f) other - please specify (อื่นๆ โปรดระบุ) .....

18. Which part of the contractual standard ISO 9000 do you hope to be certified?

ท่านต้องการขอรับการรับรองตามมาตรฐานฉบับใด

- a) ISO 9001
- b) ISO 9002
- c) ISO 9003

19. Which approach is being adapted in implementing the ISO 9000 quality system in your company? การนำมาซึ่งการใช้ระบบคุณภาพ ISO 9000 ในบริษัทของท่าน

- a) top - down เป็นคำสั่งจากผู้บริหาร
- b) bottom - up เป็นความต้องการของระดับล่าง และนำเสนอเพื่อให้ผู้บริหารเห็นชอบ
- c) both (top - down and bottom - up) ทั้งสองประการ

20. Please indicate the degree of involvement of the top management in your company in implementing the ISO 9000 quality system. โปรดระบุว่าผู้บริหารสูงสุดของท่านมีส่วนร่วมในการนำระบบคุณภาพ ISO 9000 มาใช้ขนาดไหน

- a) fully involved มีส่วนร่วมเต็มที่
- b) fairly involved มีส่วนร่วม
- c) slightly involved มีส่วนร่วมน้อย
- d) not involved at all ไม่มีส่วนร่วมเลย

21. Who is / will be the management representative (ISO 90001 (4.1.2.3))? ใครเป็นผู้แทนฝ่ายบริหาร ตามข้อกำหนด 4.1.2.3

(โปรดระบุชื่อ).....

22. Please give the position and responsibility of the person who is/will be assigned to be the QMR in your company โปรดระบุตำแหน่ง และความรับผิดชอบของผู้ที่ได้รับการแต่งตั้งเป็นผู้แทนฝ่ายบริหาร

.....

23. How long have you been implementing ISO 9000 quality system? ท่านนำระบบ ISO 9000 มาใช้นานเพียงใด

- a) less than 1 year น้อยกว่า 1 ปี
- b) 1 - 3 years ระหว่าง 1-3 ปี
- c) more than 3 year มากกว่า 3 ปี

24. Have you been certified by certification body? ท่านได้รับการรับรองจากหน่วยงานให้การรับรองแล้วหรือ

- a) not yet but we plan to be certified by ยังไม่ได้รับการรับรอง แต่ วางแผนไว้ว่า จะได้รับการรับรองภายใน .....(month ระบุเดือน) .....(year ระบุปี) by โดย, ระบุหน่วยงานให้การรับรอง .....

How long has your company been preparing for ISO 9000 certification? ใช้เวลานานเพียงใด ในการเตรียมระบบ .....(years ระบุจำนวนปี) .....(months ระบุจำนวนเดือน)

- b) yes, we were certified on ใช้ เมื่อ .. .....(month ระบุเดือน) .....(year ระบุปี) by โดย, ระบุหน่วยงานให้การรับรอง .....

How long did it take your company to achieve ISO 9000 certification starting from the preparation stage? ท่านใช้เวลานานเพียงใดตั้งแต่เริ่มต้นเตรียมระบบ จนกระทั่งได้รับการรับรอง .....(years ระบุจำนวนปี) .....(months ระบุจำนวนเดือน)

25. Did you hire consultant(s) to help you to implement ISO 9000? ท่านจ้างที่ปรึกษาหรือไม่

- a) yes - please the name of the company จ้าง - โปรดระบุชื่อบริษัท.....

- b) no - please give reason ไม่จ้าง - โปรดให้เหตุผล .....

26. Can you please indicate any part(s) of ISO 9000 which you are finding / found difficult to understand? (in your answer please indicate the paragraph of the standard, e.g. 3.1, 4.1.3, etc.) ส่วนใดของ ISO 9000 ที่ท่านพบว่ายากที่จะเข้าใจ อาจตอบเป็นหมายเลขหน้าหน้าข้อ ในมาตรฐาน .....

27. Which ISO 9000 requirements (4.1 to 4.20) did you find/ are you finding to be most difficult in the preparation of the quality manual and procedure manual? ข้อกำหนดใดที่ท่านพบว่ายากที่สุดในการเตรียมคู่มือคุณภาพ และ ขั้นตอนการปฏิบัติงาน



28. Which specific requirements of the ISO 9000 standard (4.1 to 4.20) were/are most difficult for your company to implement? ข้อกำหนดใดที่ยากที่สุดในการปฏิบัติตามได้ในบริษัทของท่าน .....

29. In implementing the ISO 9000 quality system how much effort was/is made in the following? ในการนำระบบคุณภาพ ISO 9000 มาใช้ ท่านจำเป็นต้องใช้ความพยายามกับสิ่งเหล่านี้เพียงใด

	None ไม่เลย	Little น้อย	Some มีบ้าง	A lot มาก
a) convincing senior management การอธิบายกับผู้บริหาร .....				
b) dispelling negative attitudes / resistance in the rest of the work force แก่ทัศนคติด้านลบ และการต่อต้านกับผู้ที่ไม่เห็นด้วย .....				
c) changing the company culture แก่ไขวัฒนธรรมองค์กร .....				
d) other - please specify อื่นๆ โปรดระบุ .....				

30. Since you started to implement ISO 9000 quality system has the company increased its overall market share? ตั้งแต่ท่านเริ่มใช้ระบบ ISO 9000 ท่านมีส่วนแบ่งตลาดของผลิตภัณฑ์ที่อยู่ภายใต้ระบบดังกล่าวโดยรวม เพิ่มขึ้นหรือไม่

- a) yes เพิ่ม if possible give estimate of increase in per cent โปรดระบุจำนวนเป็นเปอร์เซ็นต์ ..... %
- b) no ไม่เพิ่ม
- c) do not know yet ยังไม่ทราบแน่ชัด

31. In your opinion how much of the increase in market share was / will be due to ISO 9000 implementation? ในความเห็นของท่าน การเพิ่มขึ้นของส่วนแบ่งตลาดเป็นผลมาจากการใช้ระบบ ISO 9000 มากน้อยเพียงใด

- a) None ไม่มีผลเลย
- b) Little มีผลเล็กน้อย
- c) Some มีผลบ้าง
- d) A lot มีผลมาก
- e) All มีผลทั้งหมด

32. Since you started to implement ISO 9000 quality system has the company increased its export market? ตั้งแต่ท่านเริ่มใช้ระบบ ISO 9000 ตลาดส่งออกของผลิตภัณฑ์ของที่อยู่ภายใต้ระบบดังกล่าวโดยรวม เพิ่มขึ้นหรือไม่

- a) yes เพิ่ม if possible give estimate of increase in per cent โปรดระบุจำนวนเป็นเปอร์เซ็นต์ ..... %
- b) no ไม่เพิ่ม
- c) do not know yet ยังไม่ทราบแน่ชัด

33. In your opinion how much of the increase in export market was / will be due to ISO 9000 implementation? ในความเห็นของท่าน การเพิ่มขึ้นของตลาดส่งออกเป็นผลมาจากการใช้ระบบ ISO 9000 มากน้อยเพียงใด
- a) None ไม่มีผลเลย
  - b) Little มีผลเล็กน้อย
  - c) Some มีผลบ้าง
  - d) A lot มีผลมาก
  - e) All มีผลทั้งหมด
34. Since you started to implement ISO 9000 quality system have the company quality costs decreased? ตั้งแต่ท่านเริ่มใช้ระบบ ISO 9000 ค่าใช้จ่ายทางด้านคุณภาพของการผลิต ผลิตภัณฑ์ที่อยู่ภายใต้ระบบดังกล่าวโดยรวม เช่น ค่าตรวจสอบ หรือ ค่าชดเชยของเสีย เพิ่มขึ้นหรือไม่
- a) yes เพิ่ม if possible give estimate of increase in per cent โปรดระบุจำนวนเป็นเปอร์เซ็นต์ ..... %
  - b) no ไม่เพิ่ม
  - c) do not know yet ยังไม่ทราบแน่ชัด
35. In your opinion how much of the decrease in quality cost was / will be due to ISO 9000 implementation? ในความเห็นของท่าน การเพิ่มขึ้นของค่าใช้จ่ายทางด้านคุณภาพดังกล่าวเป็นผลมาจากการใช้ระบบ ISO 9000 มากน้อยเพียงใด
- a) None ไม่มีผลเลย
  - b) Little มีผลเล็กน้อย
  - c) Some มีผลบ้าง
  - d) A lot มีผลมาก
  - e) All มีผลทั้งหมด
36. Since you started to implement ISO 9000 quality system has the company turnover increased? ตั้งแต่ท่านเริ่มใช้ระบบ ISO 9000 รายได้ของการขายผลิตภัณฑ์โดยรวม เพิ่มขึ้นหรือไม่
- a) yes เพิ่ม if possible give estimate of increase in per cent โปรดระบุจำนวนเป็นเปอร์เซ็นต์ ..... %
  - b) no ไม่เพิ่ม
  - c) do not know yet ยังไม่ทราบแน่ชัด
37. In your opinion how much of the increase in turnover was / will be due to ISO 9000 implementation? ในความเห็นของท่าน การเพิ่มขึ้นรายได้ดังกล่าวเป็นผลมาจากการใช้ระบบ ISO 9000 มากน้อยเพียงใด
- a) None ไม่มีผลเลย
  - b) Little มีผลเล็กน้อย
  - c) Some มีผลบ้าง
  - d) A lot มีผลมาก
  - e) All มีผลทั้งหมด



38. After achieving ISO 9000 certification what are the likely benefits and how important are they? Please indicate by using the number 1, 2, 3 and 4 for items a, b, ...to g. เมื่อได้รับการรับรองระบบ ISO 9000 อะไรคือประโยชน์ที่เกิดขึ้น และมีความสำคัญเพียงใด โปรดใส่หมายเลขทุกข้อ

very important	ได้ประโยชน์ที่สำคัญอย่างยิ่งใส่หมายเลข	1
Important	ได้ประโยชน์ที่สำคัญใส่หมายเลข	2
Not very important	ได้ประโยชน์ที่ไม่ค่อยสำคัญใส่หมายเลข	3
Not at all important	ได้ประโยชน์ที่ไม่สำคัญเลยใส่หมายเลข	4

- a) consistency in the working procedures  
ความสม่ำเสมอของเอกสารขั้นตอนการทำงาน .....
- b) better understanding of processes and responsibility  
เข้าใจในกระบวนการ และความรับผิดชอบได้ดีขึ้น .....
- c) better understanding of management of quality  
เข้าใจการจัดการคุณภาพดีขึ้น .....
- d) reduce customer complaint and return of products  
ลดการได้รับสินค้าส่งคืนและคำร้องเรียนจากลูกค้า .....
- e) reduce rejected rate ลดอัตราการ reject สินค้า .....
- f) good teamwork สร้างทีมการทำงานที่ดี .....
- g) other- please specify อื่นๆ โปรดระบุ .....

39. After you have achieved ISO 9000 certification what is / will be your main goal? specify one only หลังจากได้รับการรับรอง ISO 9000 แล้ว อะไรคือ เป้าหมายที่ท่านจะทำต่อไป โปรดเลือกเพียง 1 หัวข้อ

- a) maintain certification รักษาการรับรองไว้ให้ได้
- b) fine - tune existing procedures ปรับระบบและขั้นตอนในรายละเอียดให้ดีขึ้น
- c) continuously improve what you do ปรับปรุงสิ่งที่ทำอยู่อย่างต่อเนื่อง
- d) other - please specify อื่นๆ โปรดระบุ .....

**SECTION III TQM DETAILS ส่วนที่ 2 รายละเอียด TQM**

40. What are you going to do next to improve what your company has been doing? บริษัทของท่านกำลังจะทำสิ่งใดต่อไปเพื่อปรับปรุงงานที่ทำอยู่

.....

.....

.....

41. Have you implemented /Are you planning to implement TQM (Continuous improvement)? ท่าน  
ได้ใช้ หรือมีแผนที่จะใช้ TQM หรือ การปรับปรุงอย่างต่อเนื่องหรือไม่

a) yes ใช่

b) no because ไม่ใช่ เนื่องจาก .....

.....  
.....  
(if the answer is no please skip item 42 to 51 and go to item 52) ถ้าตอบไม่ใช่ กรุณา  
ข้ามข้อ 42-51 ไปตอบข้อ 52

42. Which TQM gurus have you adopted / are you adopting in your company? ท่านนำแนว  
คิดทางด้าน TQM ของปราชญ์ท่านใดมาใช้ดำเนินการในบริษัทของท่าน

a) W. Edwards Deming

b) J. M. Juran

c) P. Crosby

d) A.V. Feigenbaum

e) other - please specify อื่นๆ โปรดระบุ .....

43. How long have you been implementing TQM? ท่านนำระบบ TQM มาใช้นานเพียงใด

a) less than 1 year น้อยกว่า 1 ปี

b) 1 - 3 years ระหว่าง 1-3 ปี

c) more than 3 years มากกว่า 3 ปี

44. Since you started to implement TQM has the company increased its market share  
overall? ตั้งแต่ท่านเริ่มใช้ระบบ TQM ท่านมีส่วนแบ่งตลาดของผลิตภัณฑ์ของบริษัทที่อยู่ภายใต้  
ระบบดังกล่าวโดยรวม เพิ่มขึ้นหรือไม่

a) yes เพิ่ม if possible give estimate of increase in per cent โปรดระบุจำนวนเป็นเปอร์เซ็นต์ ..... %

b) no ไม่เพิ่ม

c) do not know yet ยังไม่ทราบแน่ชัด

45. In your opinion how much of the increase in market share was / will be due to TQM  
implementation? ในความเห็นของท่าน การเพิ่มขึ้นของส่วนแบ่งตลาดเป็นผลมาจากการใช้ระบบ  
TQM มากน้อยเพียงใด

a) None ไม่มีผลเลย

b) Little มีผลเล็กน้อย

c) Some มีผลบ้าง

d) A lot มีผลมาก

e) All มีผลทั้งหมด



46. Since you started to implement TQM has the company increased its export market?  
ตั้งแต่ท่านเริ่มใช้ระบบ TQM ตลาดส่งออกของผลิตภัณฑ์ของบริษัทที่อยู่ภายใต้ระบบดังกล่าว โดยรวม เพิ่มขึ้นหรือไม่
- a) yes เพิ่ม if possible give estimate of increase in per cent โปรดระบุจำนวนเป็นเปอร์เซ็นต์ ..... %  
b) no ไม่เพิ่ม  
c) do not know yet ยังไม่ทราบแน่ชัด
47. In your opinion how much of the increase in export market was / will be due to TQM implementation?  
ในความเห็นของท่าน การเพิ่มขึ้นของตลาดส่งออกเป็นผลมาจากการใช้ระบบ TQM มากน้อยเพียงใด
- a) None ไม่มีผลเลย  
b) Little มีผลเล็กน้อย  
c) Some มีผลบ้าง  
d) A lot มีผลมาก  
e) All มีผลทั้งหมด
48. Since you started to implement TQM have the company quality costs decreased?  
ตั้งแต่ท่านเริ่มใช้ระบบ TQM ค่าใช้จ่ายทางด้านคุณภาพของการผลิตผลิตภัณฑ์ที่อยู่ภายใต้ระบบดังกล่าว โดยรวม เช่น ค่าตรวจสอบ หรือ ค่าชดเชยของเสีย เพิ่มขึ้นหรือไม่
- a) yes เพิ่ม if possible give estimate of increase in per cent โปรดระบุจำนวนเป็นเปอร์เซ็นต์ ..... %  
b) no ไม่เพิ่ม  
c) do not know yet ยังไม่ทราบแน่ชัด
49. In your opinion how much of the decrease in quality cost was / will be due to TQM implementation?  
ในความเห็นของท่าน การเพิ่มขึ้นของค่าใช้จ่ายทางด้านคุณภาพดังกล่าวเป็นผลมาจากการใช้ระบบ TQM มากน้อยเพียงใด
- a) None ไม่มีผลเลย  
b) Little มีผลเล็กน้อย  
c) Some มีผลบ้าง  
d) A lot มีผลมาก  
e) All มีผลทั้งหมด
50. Since you started to implement TQM has the company turnover increased?  
ตั้งแต่ท่านเริ่มใช้ระบบ TQM รายได้ของการขายผลิตภัณฑ์โดยรวม เพิ่มขึ้นหรือไม่
- a) yes เพิ่ม if possible give estimate of increase in per cent โปรดระบุจำนวนเป็นเปอร์เซ็นต์ ..... %  
b) no ไม่เพิ่ม  
c) do not know yet ยังไม่ทราบแน่ชัด

51. In your opinion how much of the increase in turnover was / will be due to TQM implementation? ในความเห็นของท่าน การเพิ่มขึ้นของรายได้ดังกล่าวเป็นผลมาจากการใช้ระบบ TQM มากน้อยเพียงใด

- a) None ไม่มีผลเลย
- b) Little มีผลเล็กน้อย
- c) Some มีผลบ้าง
- d) A lot มีผลมาก
- e) All มีผลทั้งหมด

52. What tools of quality management are used in your company? ท่านใช้เทคนิคการจัดการคุณภาพอะไรบ้างในบริษัทของท่าน

Please tick box. โปรดทำเครื่องหมายในช่องสี่เหลี่ยม

- a) statistic sampling
- b) statistical process control
- c) quality circles
- d) team building
- e) problem solving techniques (7 tools)
- f) Taguchi techniques
- g) internal audits
- h) quality costing
- i) quality function deployment (QFD)
- j) leadership development
- k) system optimization
- l) remove barriers to pride of workmanship
- m) empowering the workforce
- n) training the workforce
- o) benchmarking
- p) other - please specify .....
- .....

Please tick here if you would like to receive a copy of the summary of the results.

โปรดทำเครื่องหมายในช่องถ้าท่านต้องการผลของการวิจัยนี้



**Appendix 2: Consulting plan**

ISO 9000 Consulting Support Project

ID	Name	Duration	Scheduled Start	Scheduled Finish	Q2 '97			Q3 '97			Q4 '97			Q1 '98			Q2 '98			Q3 '98		
					Mar	Apr	May	Jun	Jul	Aug	Sep	Oct	Nov	Dec	Jan	Feb	Mar	Apr	May	Jun	Jul	Aug
1	Executive Training	1d	7/4/97 8:00	7/4/97 17:00																		
2	Baseline Evaluation for companies	10d	8/4/97 8:00	24/4/97 17:00																		
8	Review Baseline and introduce concept	1d	25/4/97 8:00	25/4/97 17:00																		
9	Resp Matrix & Macro Flowchart	10d	28/4/97 8:00	13/5/97 17:00																		
15	Interpretation of ISO 9000 course	1d	14/5/97 8:00	14/5/97 17:00																		
16	Documentation Course	2d	15/5/97 8:00	16/5/97 17:00																		
17	Evelution of documents and progress for each company (2 days/com)	10d	16/6/97 8:00	27/6/97 17:00																		
23	Management planning	0d	21/6/97 8:00	21/6/97 8:00																		
24	Evaluation of progress (1 day/com)	5d	8/9/97 8:00	12/9/97 17:00																		
30	Internal Auditor Course	3d	15/9/97 8:00	17/9/97 17:00																		
31	Audit Training for companies	10d	18/9/97 8:00	1/10/97 17:00																		
37	Evaluation of documents for company (2 days/com)	10d	17/11/97 8:00	28/11/97 17:00																		
43	Management Planning	0d	22/11/97 8:00	22/11/97 8:00																		
44	Evelution of documents and progress (2 day/com)	10d	26/1/98 8:00	6/2/98 17:00																		
50	Management planning	0d	31/1/98 8:00	31/1/98 8:00																		
51	Evelution of progress (1 day/com)	5d	20/4/98 8:00	24/4/98 17:00																		
57	Management planning	0d	25/4/98 8:00	25/4/98 8:00																		
58	Preassessment and corrective action for companies (4 days/com)	20d	1/6/98 8:00	26/6/98 17:00																		

Project ISO 9000 Supporting project  
 Date 22/6/97

Critical  
 Noncritical

Progress  
 Milestone

Summary  
 Rolled Up



### **Appendix 3: Structured interview**

## STRUCTURED INTERVIEW 1ST VISIT

During the baseline audit in the company, the researcher or her colleague will interview the auditees. Since the researcher and team members will audit a number of departments which are responsible for ISO 9000 requirements, they will have an opportunity to interview people in particular department, to observe their work and attitude to ISO 9000 implementation and to assess each department's documentation. Questions therefore are designed for audit team members according to ISO 9000 requirements. Auditors start auditing a particular department by interviewing the manager who is in charge of the department. Then auditors audit them according to ISO 9000 audit checklist. During the audit, auditors observe and record their comments from time to time.

In addition, the researcher will conduct a structured interview with the company "Quality Management Representative (QMR)" to try to obtain the whole picture of the company.

The expected reports from baseline evaluation which will be used for qualitative analysis are as follows:

1. structure interview reports (from interviewer)
2. audit reports (from lead auditor)
3. report of general impression from observation (from the researcher or audit team members)

### QMR structured interview

#### Section 1 Company details ( some information can be extracted from application)

1. Name .....
2. Job title (apart from Quality Management Representative)  
.....
3. Company name .....
4. Company address .....
5. Telephone number .....
6. Fax number .....
7. Email account .....
8. Is the company 100% Thai owned?
  - a) yes
  - b) joint venture (please specify nationality) .....
  - c) 100% foreign owned please specify nationality .....
9. Number of employees .....
10. Capital investment ..... Baht
11. Main area of manufacturing .....
12. Percentage of total sales exported ..... %
13. Turnover achieved in the last financial year ..... Baht



**Section 2 ISO 9000 knowledge and attitude**

14. When did you first learn about ISO 9000?  
a) less than 1 year ago  
b) 1 - 3 years ago  
c) more than 3 years ago
15. How did you find out about ISO 9000?  
a) your competitor has it  
b) your parent company  
c) your customer  
d) your employee  
e) consultant  
f) business publication  
g) other please specify .....
16. Have you attended a ISO 9000 seminar and/or course before this executive course under the NSTDA supported project? If yes, please explain type and context of seminar/course  
.....  
.....  
.....
17. Why do you want to be certified to an ISO 9000 series standard?  
a) customer pressure  
b) parent company corporate policy  
c) marketing of company product  
d) competitor have been certified  
e) global competitiveness  
f) internal improvement  
g) project in TQM program  
h) other please specify .....
18. To which part of the ISO 9000 series contractual standard do you want to be certified?  
a) ISO 9001  
b) ISO 9002  
c) ISO 9003  
d) do not know
19. What do you expect from ISO 9000?  
a) improved product quality  
b) quality cost reduction  
c) good team work  
d) quality consciousness and commitment among employees  
e) consistent product quality  
f) a better documentation system  
g) standardized work procedures  
h) other please specify .....
20. Has your company ever been audited by a customer (2nd party audit)? .....
21. If yes to Q.20, when and how often? .....

22. Do you think ISO 9000 will help you reduce customer audit? If so, why?

.....  
.....  
.....

23. Have your employees been trained on ISO 9000?

- a) no
- b) yes, who (which positions) have been trained?

.....  
.....

24. How many members are there in core team in your company to work on ISO 9000 project and who are they?

.....  
.....  
.....

25. How are your management, staff or employees involved in initiating the ISO 9000 project?

- a) project is initiated from top management (company policy)
- b) project is initiated from top/middle management meeting
- c) project is initiated from QA department (the department, whatever it has been called, which is in charge of quality control and inspection)
- d) ISO 9000 project is initiated from

.....  
.....

26. What do you think it will be the most difficult problem to cope with during the implementation process?

- a) interpretation of ISO 9000 requirements
- b) establishment of the documentation system
- c) training workforce to understand and implement ISO 9000 system
- d) changing company culture
- e) other please specify

.....  
.....  
.....

27. Which certification body do you want to be certified with? Why?

.....  
.....  
.....



**Section 3 ISO 9000 requirements**

28. How much do you understand the particular elements of ISO 9001/2/3?  
 29. How difficult is each particular element for your company to document?  
 30. How difficult do you expect each element to implement in your company?  
 31. How much of each particular element does your company already have in place?  
 Please identify the degree of what you think is appropriate,  
 1 = not at all; 2 = a little; 3 = some; 4 = a lot

Clause	ISO 9001/2/3 requirements	Q. 28	Q. 29	Q. 30	Q. 31
4.1	Management responsibility				
4.2	Quality system				
4.3	Contract review				
4.4	Design control (ISO9001 only)				
4.5	Document and data control				
4.6	Purchasing				
4.7	Control of customer - supplied product				
4.8	Product identification and traceability				
4.9	Process control				
4.10	Inspection and testing				
4.11	Control of inspection and test equipment				
4.12	Inspection and test status				
4.13	Control of nonconforming product				
4.14	Corrective and preventive action				
4.15	Handling, storage, packaging, preservation and delivery				
4.16	control of quality records				
4.17	Internal quality audits				
4.18	Training				
4.19	Servicing				
4.20	Statistical techniques				

**Section 4 Attitudes about quality management and TQM**

32. Please describe the attitudes of your workforce regarding quality

- a) little or no awareness of quality
- b) difficult to persuade because they think it means more work
- c) easy to persuade but not initially conscious by themselves of quality issues
- d) substantial existing quality consciousness among workforce
- e) other please specify

.....  
.....

33. What do you think is the most important motivation for your employees to work effectively towards the objectives of your company?

.....  
.....  
.....

34. What quality management tools are you using now in your company?

.....  
.....  
.....

35. What is the extent of your knowledge of TQM ideas?

.....  
.....  
.....

36. What is your own attitude towards TQM?

- a) acceptance
- b) objection
- c) scepticism
- d) other comment

.....  
.....

37. What is the attitude towards TQM of other top and middle management?

- a) acceptance
- b) objection
- c) scepticism
- d) other comment

.....  
.....

38. Have you ever heard about the quality gurus? Whom do you know of?

.....  
.....

39. Do you have a plan to implement TQM in your company? Why?

.....  
.....  
.....

40. What benefits would you expect from TQM implementation?

.....  
.....  
.....



41. Do you have a training program on quality for your employees? If yes, what kind of course do you provide and what are the benefits?

.....  
.....  
.....

## **Departmental Manager Structured Interview**

During the baseline audit in the company, the researcher or her colleague will interview the auditees. Since the researcher and team members will audit a number of departments which are responsible for ISO 9000 requirements, they will have an opportunity to interview people in particular department, to observe their work and attitude to ISO 9000 implementation and to assess each department's documentation. Questions therefore are designed for audit team members according to ISO 9000 requirements. Auditors start auditing a particular department by interviewing the manager who is in charge of the department. Then auditors audit them according to ISO 9000 audit checklist. During the audit, auditors observe and record their comments from time to time.

In addition, the researcher will conduct a structured interview with the company "Quality Management Representative (QMR)" to try to obtain the whole picture of the company.

The expected reports from baseline evaluation which will be used for qualitative analysis are as follows:

1. structure interview reports (from interviewer)
2. audit reports (from lead auditor)
3. report of general impression from observation (from the researcher or audit team members)

### **Section 1 Interviewee details**

1. Name .....
2. Job title .....
3. Telephone number (or extension number) .....
4. Fax number .....
5. Email account .....
6. How long have you been in your current position? .....
7. What were your previous position and responsibilities? How long were in that position?  
.....  
.....



**Section 2 ISO 9000 knowledge and attitude**

8. When did you first learn about ISO 9000?

- a) less than 1 year ago
- b) 1 - 3 years ago
- c) more than 3 years ago

9. How did you find out about ISO 9000?

- a) your competitor has it
- b) your boss
- c) your parent company
- d) your customer
- e) your employee
- f) consultant
- g) business publication
- h) other please specify

10. Have you attended a ISO 9000 seminar and/or course before this executive course under the NSTDA supported project? If yes, please explain type and context of seminar/course.

.....  
.....  
.....  
.....

11. What do you expect from ISO 9000?

- a) improved product quality
- b) quality cost reduction
- c) good team work
- d) quality consciousness and commitment among employees
- e) consistent product quality
- f) a better documentation system
- g) standardized work procedures
- h) other please specify .....

12. What do you think it will be the most difficult problem to cope with during the implementation process?

- a) interpretation of ISO 9000 requirements
- b) establishment of the documentation system
- c) training workforce to understand and implement ISO 9000 system
- d) changing company culture
- e) other please specify

.....  
.....  
.....

**Section 3 ISO 9000 requirements**

- 13. How much do you understand the particular elements of ISO 9001/2/3?
  - 14. How difficult is each particular element for your company to document?
  - 15. How difficult do you expect each element to implement in your company?
  - 16. How much of each particular element does your company already have in place?
- Please identify the degree of what you think is appropriate,  
 1 = not at all; 2 = a little; 3 = some; 4 = a lot

Clause	ISO 9001/2/3 requirements	Q. 13	Q. 14	Q. 15	Q. 16
4.1	Management responsibility				
4.2	Quality system				
4.3	Contract review				
4.4	Design control (ISO9001 only)				
4.5	Document and data control				
4.6	Purchasing				
4.7	Control of customer - supplied product				
4.8	Product identification and traceability				
4.9	Process control				
4.10	Inspection and testing				
4.11	Control of inspection and test equipment				
4.12	Inspection and test status				
4.13	Control of nonconforming product				
4.14	Corrective and preventive action				
4.15	Handling, storage, packaging, preservation and delivery				
4.16	control of quality records				
4.17	Internal quality audits				
4.18	Training				
4.19	Servicing				
4.20	Statistical techniques				



**Section 4 Attitude about quality management and TQM**

17. Please describe the attitudes of your workforce regarding quality

- a) little or no awareness of quality
- b) difficult to persuade because they think it means more work
- c) easy to persuade but not initially conscious by themselves of quality issues
- d) substantial existing quality consciousness among workforce
- e) other please specify

.....  
.....

18. What do you think is the most important motivation for your employees to work effectively towards the objectives in your department?

.....  
.....

19. What quality management tools are you using now in your department?

.....  
.....

20. What is the extent of your knowledge of TQM ideas?

.....  
.....

21. What is your own attitude towards TQM?

- a) acceptance
- b) objection
- c) scepticism
- d) other comment

.....  
.....

22. What is the attitude towards TQM of other top and middle management?

- a) acceptance
- b) objection
- c) scepticism
- other comment

.....  
.....

23. Have you ever heard about the quality gurus? Whom do you know of?

.....  
.....

24. Do you think your company should implement TQM? Why?

.....  
.....

25. What benefits would you expect from TQM implementation in your department?

.....  
.....

**Appendix 4: Cognitive maps of five companies**



# Company I Cognitive mapping of MD.

30/11/98

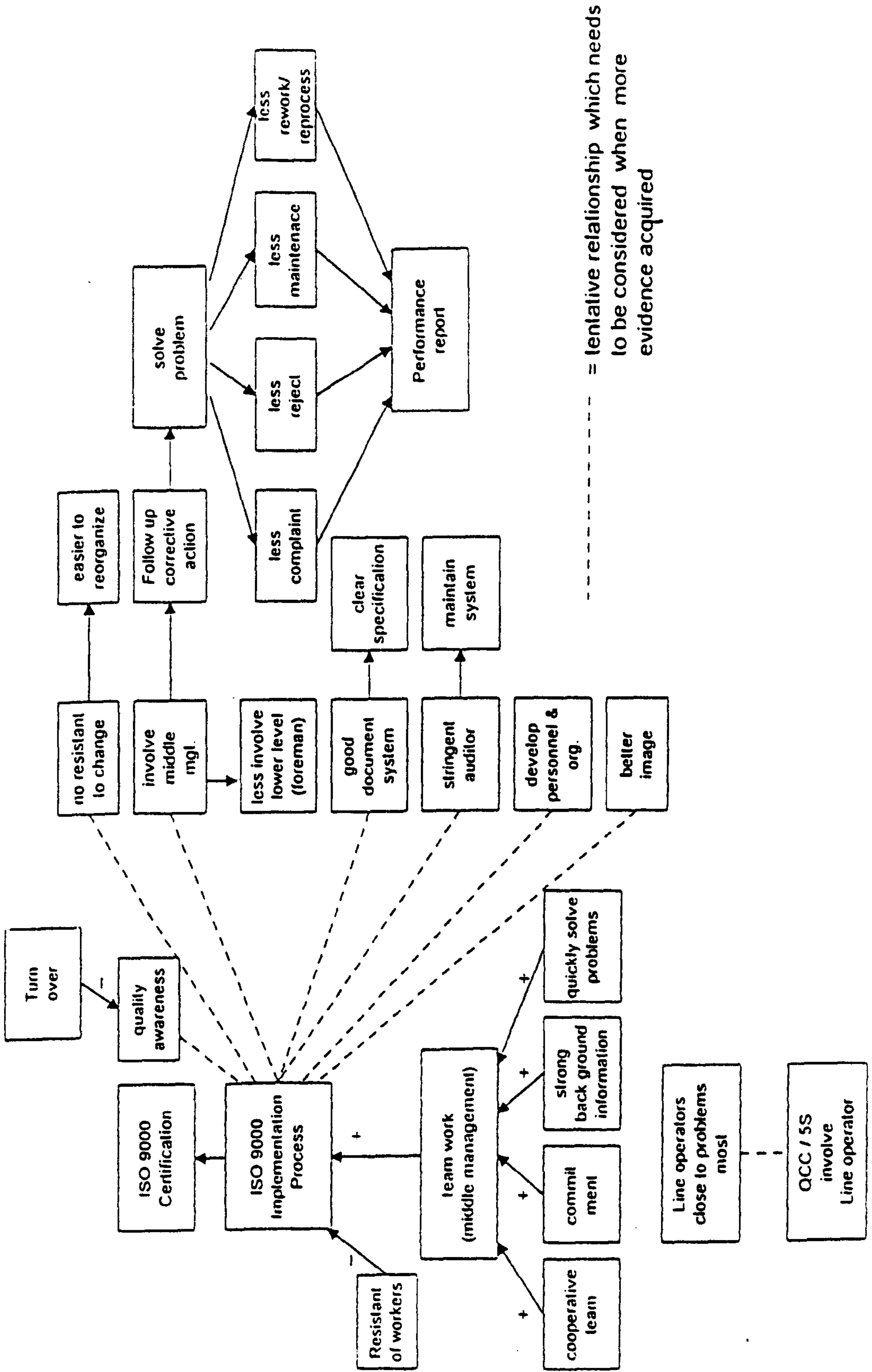

# Company I QMR.+QC manager Interview Cognitive Mapping

30/11/98

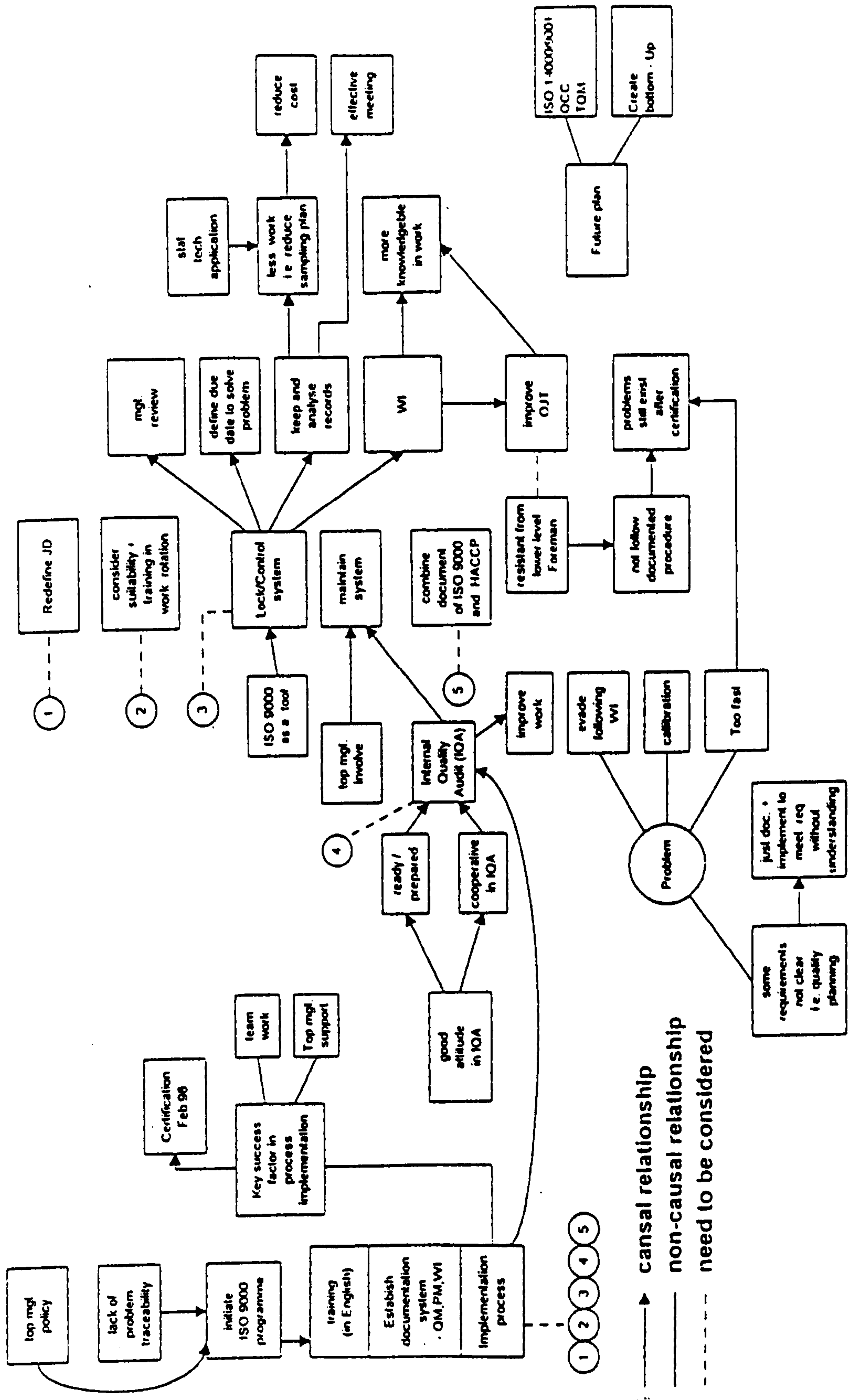



# Company II Cognitive Mapping Coding

3/12/98

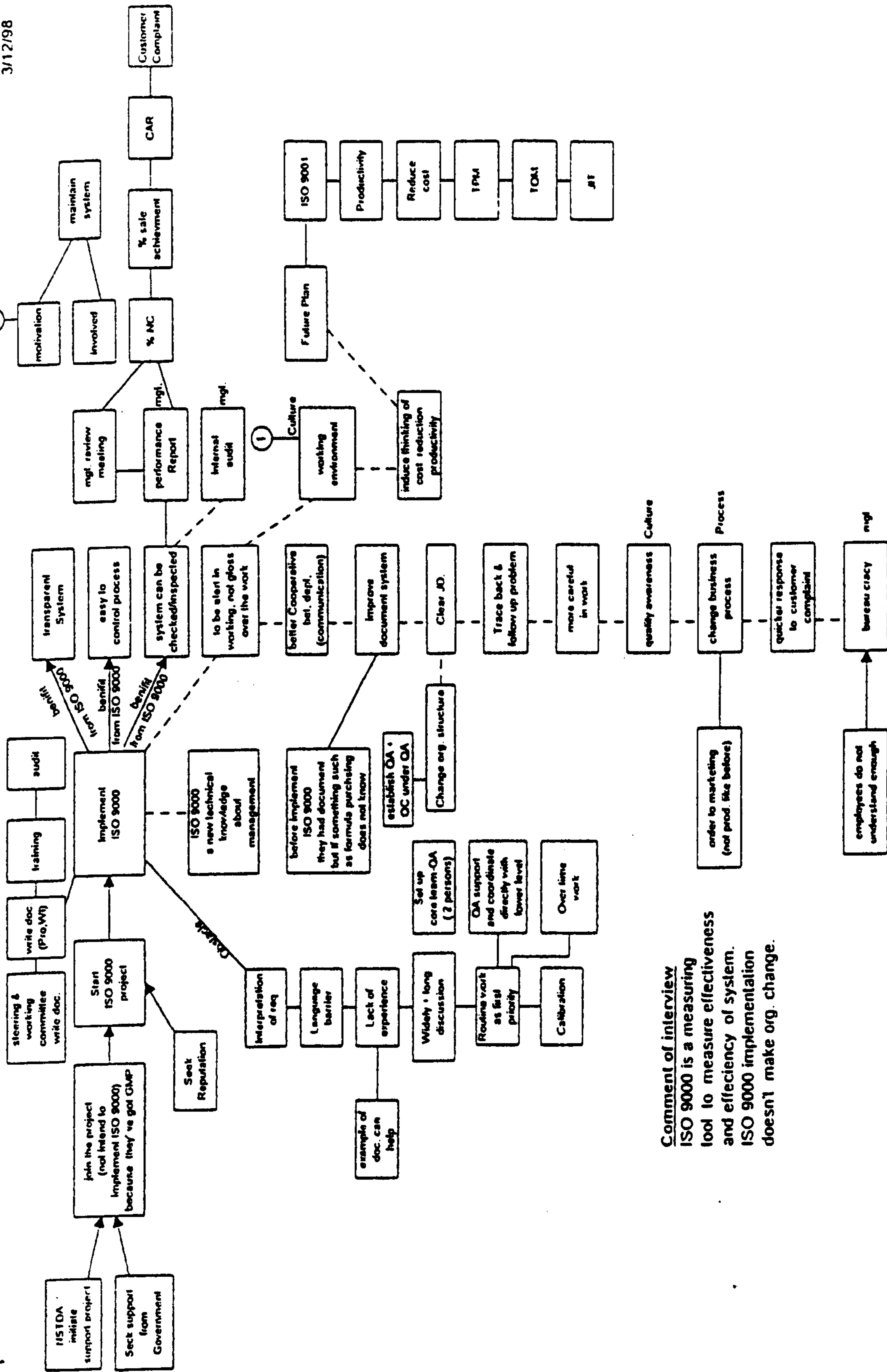

Comment of interview  
 ISO 9000 is a measuring tool to measure effectiveness and efficiency of system. ISO 9000 implementation doesn't make org. change.

# Company III Cognitive Mapping- Coding

4/12/98

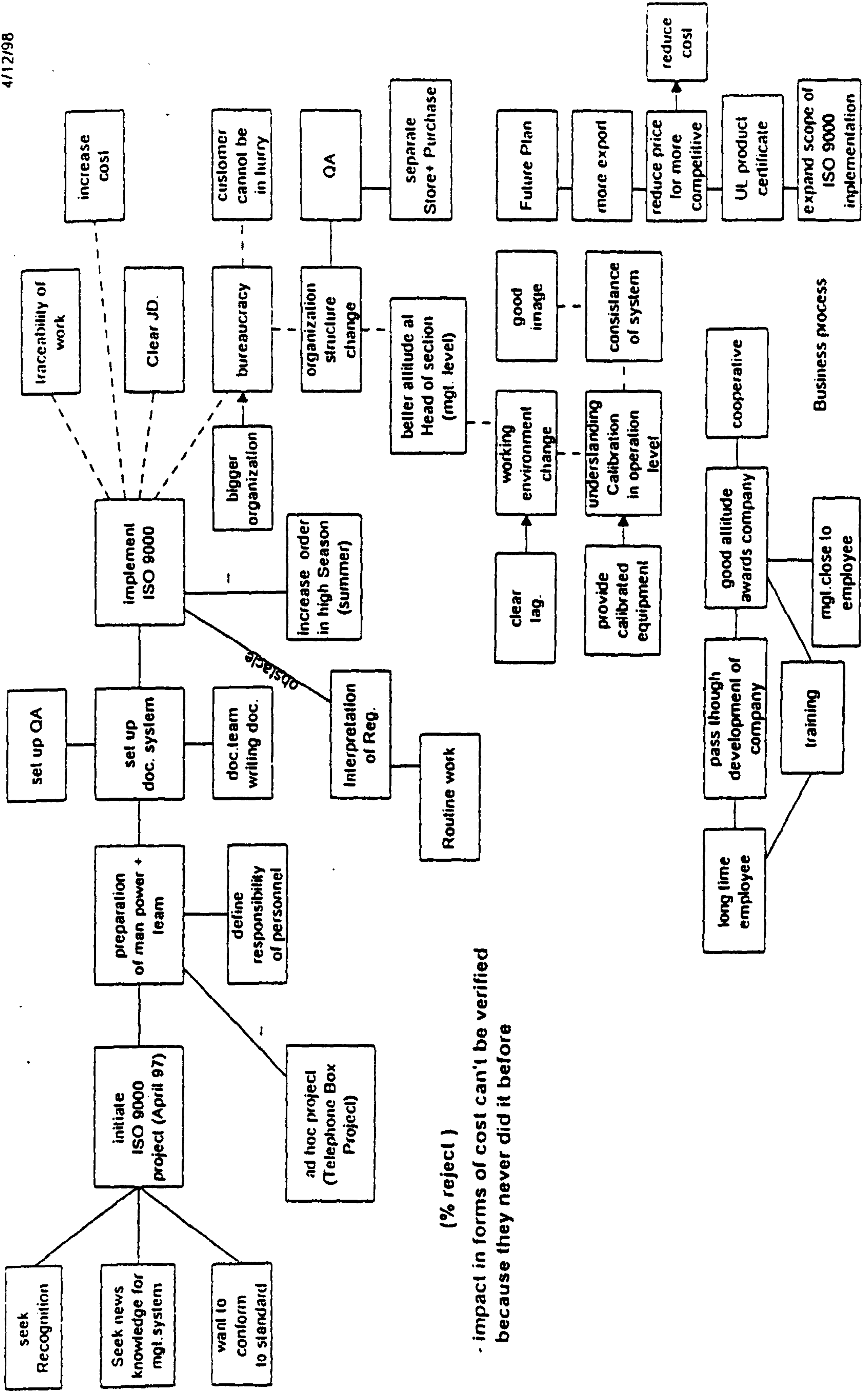

(% reject )

- impact in forms of cost can't be verified because they never did it before



Cognitive Mapping- Coding

4/12/98

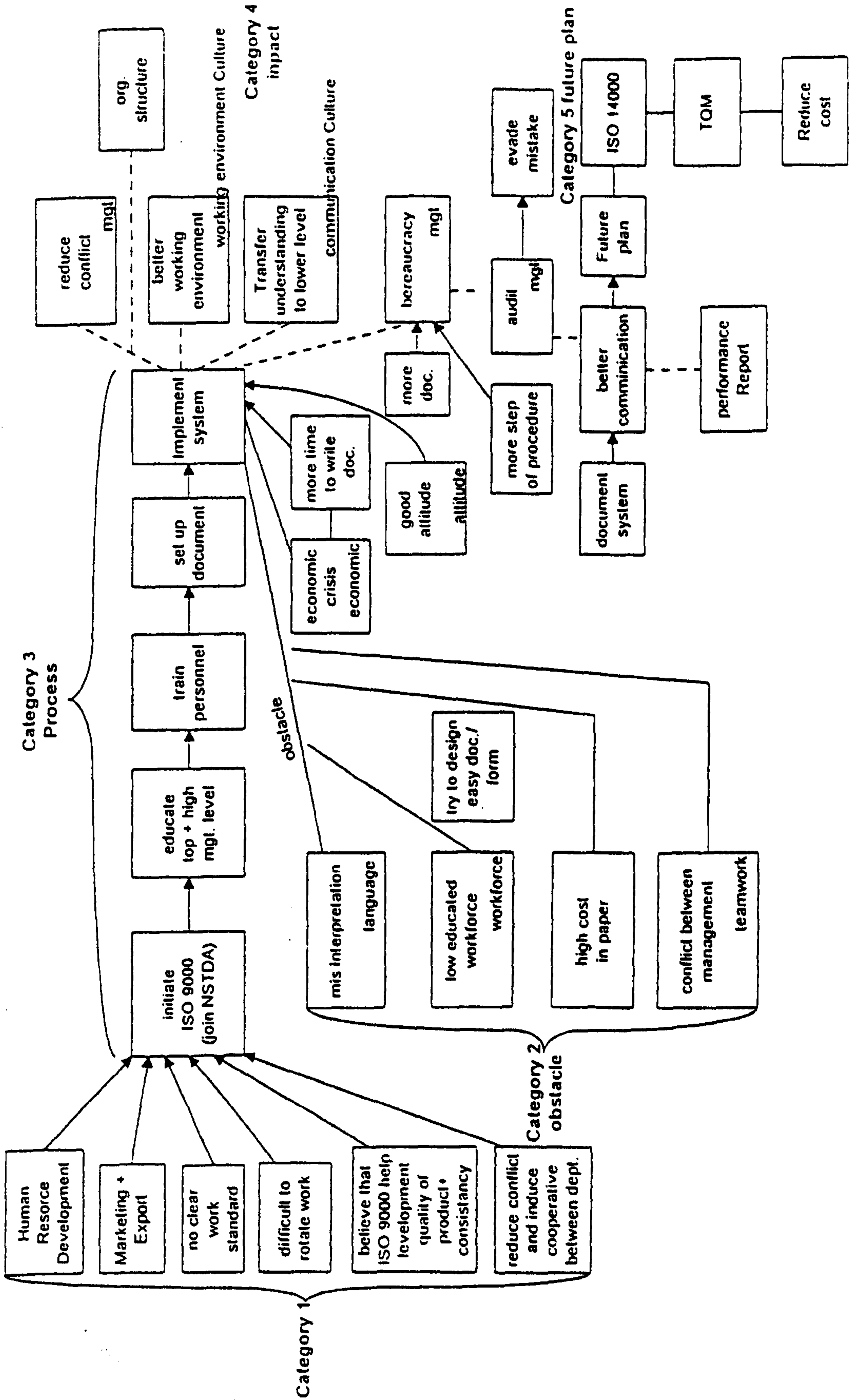

# Company V Cognitive Mapping - Coding

4/17/98

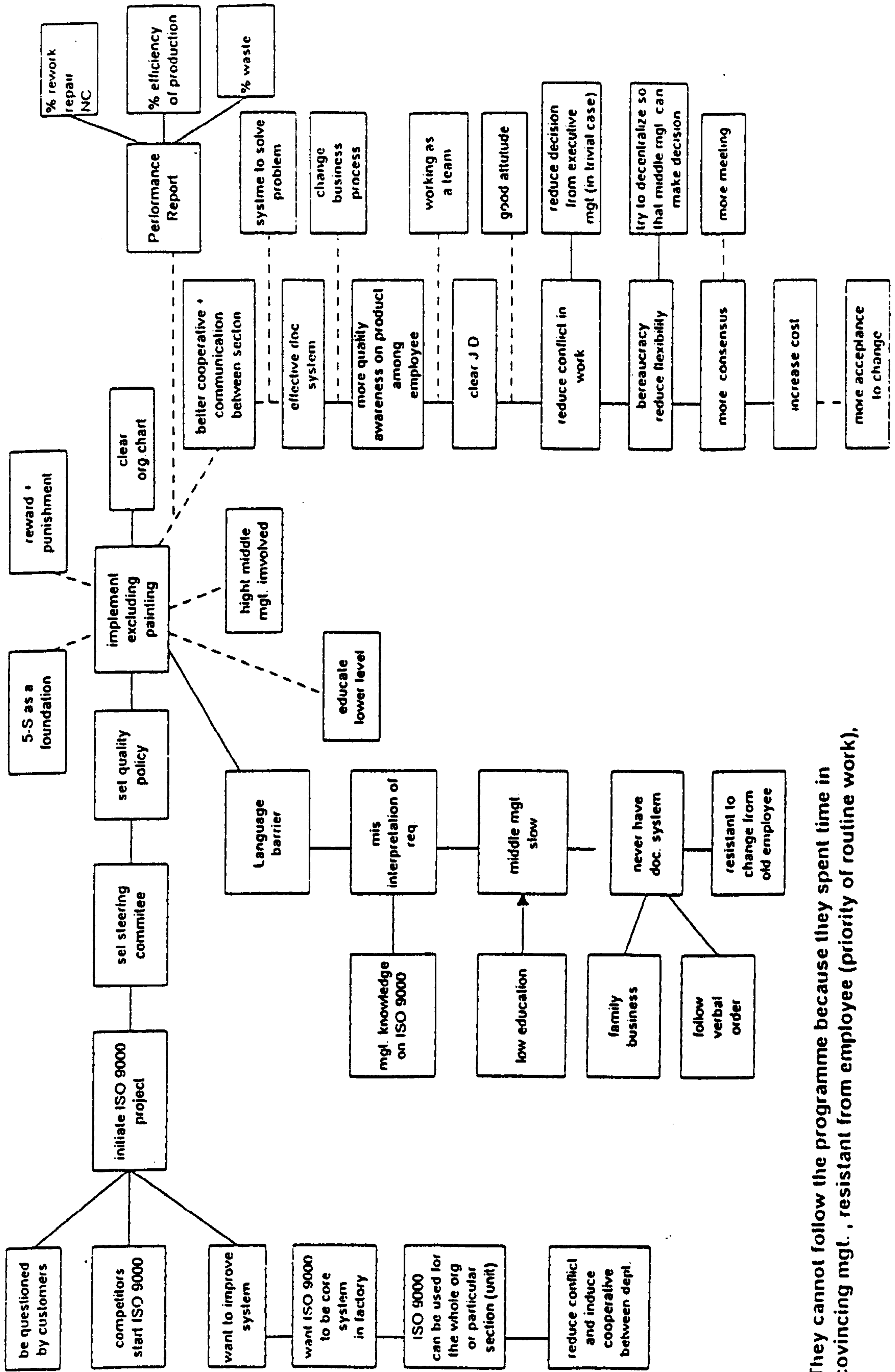

They cannot follow the programme because they spent time in convincing mgt. . resistant from employee (priority of routine work),



**Appendix 5: An example of baseline evaluation report**

**BASELINE EVALUATION  
OF  
COMPANY V**

**Address:** \_\_\_\_\_

**Evaluation Date:  
23-24 April 1997**

**Submitted:  
25 April 1997**

**Prepare by:**  
Mrs. Ladawan Krasachol  
Lead Auditor, NSTDA

**Submitted to:**  
Mr./Ms.(Name of Managing Director)  
Managing Director  
Address of company V

**Approved by:**  
Mr. George D. Ridge  
Audit Manager

**Contents:**

Evaluation Overview

1. Executive Summary
2. Areas Evaluated to ISO 9002



---

## **EVALUATION OVERVIEW**

**EVALUATION DATE**

23-24 April 1997

**PURPOSE**

This evaluation was conducted to assess 'Company V' quality system and its approximate level of compliance with the ISO 9002 standard.

**SCOPE**

The evaluation included Company V facility in Bangkok.

**PRIMARY COMPANY CONTACTS**

Name of Managing Director

Name of QMR

**PERSONS CONTACTED DURING THE EVALUATION**

List of the names of various persons interviewed

**PERSON DONDUCTING THE EVALUATION**

Mrs. Ladawan Krasachol	Technical Expert
Mr. George D. Ridge	Senior Manager Consultant
Mr. Theerawat Wongsrisung	Project Analyst

Signature/sign of

---

Mrs. Ladawan Krasachol

Technical Expert

---

**CLIENT CONFIDENTIAL**

## Section 1.0

### EXECUTIVE SUMMARY

Company V is a light fixture and trunking manufacturing company and is preparing for registration to ISO 9002

The scope of the baseline evaluation was limited to the manufacturing plant at Tung Song Hong. However the scope of registration will cover marketing division at Gypsum Metropolitan tower, 16<sup>th</sup> floor and warehouses locating in two places for lighting product and one place for trunking.

Company V has in place a number of excellent systems and defined process of manufacturing. The personnel of Company V are effective and enthusiastic. The many obstacles facing Company V in the ISO 9000 certification process are:

- Lack of formal documentation of procedures, instructions, forms, records
- Lack of documented system to approve, issue, and control required documents
- Lack of a quality assurance system to ensure the quality of their products meet requirements
- Lack of calibration system to control of inspection, measuring and test equipment.



The table below shows the performance of Company V at a glance, and indicates percentage as an approximate measure of compliance with each ISO area. (The higher the percentage, the better the performance.)

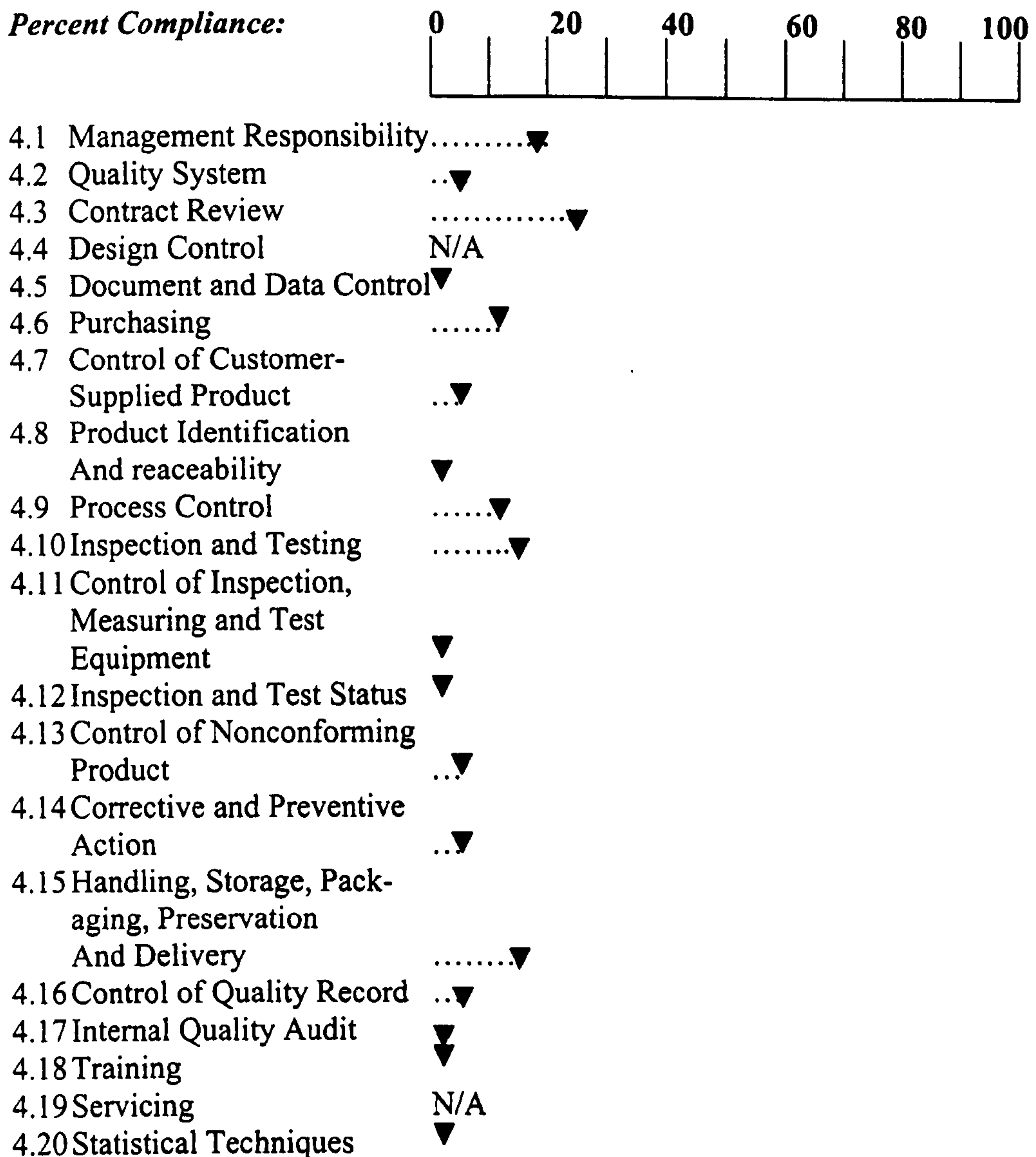

Note: The designation 'N/A' indicates that this area is not applicable to the company's operation.

---

## Section 2.0

### AREAS EVALUATION TO ISO 9002, PART 4:

- 4.1 Management Responsibility** **20%**
1. The quality policy has been defined and documented since October 1<sup>st</sup>, 1996 and signed by Managing Director. However it has not been understood, implemented and maintained at all levels of the organisation. Only working committee or department manager acknowledged that the company is going to implement ISO 9002 system.
  2. According to the company management, they define their customer needs as follow: on time delivery, quality which meet customer's specification and consistent quality of product.
  3. There is an organisation chart which shows the positions and levels of management. However the company has not defined responsibilities and authorities in a job description.
  4. The company management committee has meeting every 2 weeks to review management system and identify resource requirements of trained personnel for management, performance of work and verification activities including internal quality audits.
  5. The Lighting Division Director has been appointed to be management representative. However, it has been known only among middle to high management. They have not defined responsibilities and authorities of management representative yet.
  6. Quality Management Board (QMB) which consists of all senior management of the company has meeting every 2 weeks to review quality system of the company. The minutes of meeting are maintained.
- 4.2 Quality System** **5%**
1. There is no quality manual covering the requirements of ISO 9002.
  2. There is no system level procedure. However some of flow charts have been drafted and tried to implement.



- 
3. There is no definite quality planning to define how the requirements for quality of the company products will be met.

#### **4.3 Contract Review**

**25%**

##### **Trunking Division**

1. The company has quite good process to deal with purchase order, but there is no documented procedure for the review of all orders.
2. The company has review each purchase order according to product name, quantity, price, delivery date and customer's address, to ensure that requirements are adequately defined but no documented or working instructions supports this.
3. For each purchase order, the company will review against quotation which is sent to the company before accepted, but they do not record of such review.
4. The company does not have documented or working instruction to handle amendments to purchase order.

##### **Lighting Division**

1. The company has a subsidiary company to take care of customer's purchase order, anyway for the subsidiary company needs to conform to required review. At present, that subsidiary company does not have documented procedure or working instruction to review contract.
2. In review purchase orders, the company does review purchase order compare with its quotation, but they do not record the review result.
3. For amendment of any purchase order, customer's document that is requested to the company must be reviewed and approved by the Lighting's production manager with signed and approved date, but there is no need for customer to resubmit new purchase order from customer and the company does not issue working order to the company sale production control manager.

#### **4.4 Design Control**

**N/A**

---

**4.5 Document and Data Control** **0%**

1. The company starts collecting documents used within organisation. At present the company does not have systematic procedure for controlling all quality-related documents and data.
2. The control of documents and data must address and cover for external documents such as standards, customer drawings and specifications and so forth.
3. The company does not define responsibilities, authorities to person for reviewing documents and/or approval data before issue, and the company does not have system procedure to deal with this.
4. The company does not have system procedure/or function in reviewing and approving any documents changes.

**4.6 Purchasing** **10%**

1. There is no documented procedure for purchasing
2. There are no documented work instructions for purchasing. A flow chart has been completed showing purchasing requisition, approval and distribution of purchase orders.
3. There are visits to new subcontractors but no evaluation is made on their ability to meet subcontract requirements including the quality system. Discussion is on price, delivery, and credit terms.
4. There is no control exercised over the subcontractors except when product quality is not good. The subcontractor receives a warning and if problem is not solved, a new subcontractor is used.
5. There is no approved subcontractor list. However, incoming inspection performance records are maintained.
6. Purchase documents clearly define the material or product ordered. Inspection instructions, applicable quality standard or other technical data are not included.
7. Forms used in purchasing have no form number or revision level.
8. Purchase order are reviewed and approved by the purchasing manager prior to distribution.



- 
9. Element 4.6.4 only applies to the Trunking Division. They visit zinc-coating suppliers and complete product inspection for visual surface quality and coating thickness. Their customer also visits the coating supplier.

#### **4.7 Control of Customer-Supplied Product** **5%**

1. For the Trunking Division, there is no customer-supplied product.
2. For the Lighting Division, there is customer-supplied product such as ballast, capacitor, lamp holders, etc.
3. There is no systems level procedure or work instructions documented.
4. There is no undocumented process for customer supplied products
5. The only activity is to return a damaged or defective part to the customer for replacement.

#### **4.8 Product Identification and Traceability** **0%**

1. The company does not have a documented procedure and/or working instruction for product identification to identify product at all stages of production, delivery and installation.
2. There is no defined or undocumented process for product identification.
3. There are some returned products from customer. Lack of product identification will not effectively identify of root cause of returned product and effectively implement of corrective actions.
4. The company does not need to have documented procedure of traceability unless specified by contract or customers' requirement.

#### **4.9 Process Control** **10%**

1. There is no documented procedure for process control.
2. There are no documented work instruction defining the manner of production. Some of them are found but they are not controlled.
3. There are undocumented processes for production but controlled conditions have not been defined.
4. There are no applicable standards or codes.

- 
5. Suitable process and product characteristics have not been identified, therefore it is impossible to monitor them.
  6. Painting is a special process but criteria for qualification of the operator and equipment have not been defined. Therefore, no records are maintained.
  7. Workmanship standards, samples or illustrations have not been defined or provided for operator use.
  8. There is no documented procedure or process for preventive maintenance.

#### **4.10 Inspection and Testing**

**15%**

1. There is no system level procedure for inspection and testing.
2. The company does receiving inspection but there is no documented inspection instruction. Inspection records are maintained.
3. All raw materials and products must be inspected before release for production.
4. There is no in-process inspection being performed.
5. Lighting Division is developing in-process inspection instruction. Inspection data will be recorded on the inspection check sheet.
6. Trunking Division has no plan to develop in-process instruction.
7. Urgent release of in-process materials has not been addressed in procedures or work instructions.
8. There is no documented work instruction for final inspection. However, inspection records are maintained.
9. Although some of inspection records are being maintained, other required records need to be identified.

#### **4.11 Control of Inspection, Measuring, and Test Equipment**

**0%**

1. There is no procedure to control, calibrate and maintain inspection, measuring and test equipment.
2. There is no defined or undocumented process for calibration.
3. There are several pieces of measuring equipment but none have been calibrated since they were purchased.



---

**4.12 Inspection and Test Status****0%**

1. There is no system level procedure to identify the inspection and test status.
2. There is no process being used at the present time to show conforming or nonconforming product.

**4.13 Control of Nonconforming Product****5%**

1. There is no documented procedure for control of nonconforming material.
2. There is an informal process for evaluation and disposition but it is not effective.
3. Responsibility for disposition is not properly identified.

**4.14 Corrective and Preventive Action****5%**

1. The company has flowchart for corrective and preventive action, which is used to handle non-conformance in production line and customer complaints. However, the company does not have system-level documented procedure for corrective and preventive action, which will cover all processes, not just production division.
2. The company has process (used only in production division to take action to eliminate non-conformance based on root cause evaluation by authorised persons, anyhow in the case that root cause can not be solved, the company will mark status as 'pending' and wait until it expired. It does not comply with standard requirement.
3. The company has flowchart/work-instruction to handle customer complaints and report of nonconformances. However, the company still needs to have documented procedure to handle these and cover for all activities.
4. The company does preventive action on basis of case-by-case. It will be performed for every ECN (Engineering Change Note) issued by team of engineer manager which is not conformance with standard requirement, stated appropriate sources of information such as audit reports, quality record, training, customer complaints, management

---

review/reports and etc., should be collected and analysed for doing preventive action.

5. The company does not have documented procedure for prevention action.

#### **4.15 Handling, Storage, Packaging, Preservation and Delivery 15%**

1. There is no documented procedure for handling, storage, packaging, inventory control and delivery.
2. There are undocumented processes covering storage, packaging, inventory control and delivery. Forms have been developed in these areas.
3. Damage due to handling is not a problem in Trunking Division due to product. Operators in Lighting Division have been trained to handle the product to prevent damage.
4. Trunking Division has no specified storage areas. Materials are stored on the floor close to where used. Lighting Division has storage area with shelves to store materials.
5. Both divisions have forms to be completed when material or product is received. Another form is completed when material is withdrawn. These completed forms are used in manual inventory control system.
6. Packaging and labelling of products for shipment is specified by the company. Most trunking products are banded or loaded on truck loose. Packaging material is not used. Lighting Division product used packaging to prevent damage and to protect product during shipment. There is no protection between each layer of product.
7. There are no identified material or product where preservation is a requirement. There are raw materials in storage where rust can be a problem.
8. There are forms to be completed when product is to be delivered. It may be shipped direct to customer or to a warehouse for storage until the customer requires product. Lighting Division has two warehouses and delivery is controlled by Sales/Marketing. Trunking has one warehouse.



- 
9. There was no baseline evaluation made on the warehouse or sales or marketing.

**4.16 Control of Quality Records****5%**

1. There is no procedure for identification, collection, indexing, access, filing, storage, maintenance, and disposition of quality records.
2. The company's quality records almost do not comply with ISO requirement, no form number and no revision on it.
3. The company does not define how records to be kept damage and deterioration and to prevent loss.
4. The company does not define retention time of quality records established and records.
5. The company does keep records some as electronic media, but it does not have suitable safeguards and control implemented to assure integrity of such electronic media, such as assess control, revision and issuance control, password protection, and method for obsoleting hard copies of documents.
6. The company does not have master list for all quality records and related documents required for quality system as master documents lists, quality records lists, working instruction lists and so forth.

**4.17 Internal Quality Audit****0%**

1. The company does not perform internal quality audit to determine the effectiveness of their quality, and the company does not have system procedure for internal quality audit.

**4.18 Training****0%**

1. The company does not have system procedure and working instructions for identifying and providing the necessary training for all personnel, even though it has human resource section. The responsibilities to perform these activities do not clearly defined and taken in action.

- 
2. The company does not clearly identify the qualification of all operation positions.
  3. The company does not define job description or other suitable means utilised such as skill, education, and/or training requirements.
  4. For the position that need special-skill to perform special process such as painting or welding process, the company needs to define the qualification on the basis of appropriated education, training and/or experience.
  5. The company does not keep records of training for all personnel, including temporary employees' training records as well.

**4.19 Servicing**

N/A

**4.20 Statistical Techniques**

0%

1. The company does not have system-level procedure for statistical techniques.
2. The company does not identify the need for statistical techniques required for establishing, controlling, and verifying process capability and product characteristics.
3. The company does not define process for statistical techniques.



**Appendix 6: Proposal for a study of TQM in Thai industry**

---

## **Proposal for a study of Total Quality Management in Thai industry**

### **Introduction**

It has been accepted worldwide that one of the key factors for companies to be successful in global market is "quality". In developed countries such as UK, USA and Japan, Total Quality Management (TQM) has become a topical issue in all sectors including manufacturing industry. However, in developing country like Thailand, even though successful manufacturing industries have developed in the last two decades, TQM seems to elude many Thai industrialists. Only a few managements have adopted the concept of TQM in their companies. With the exception of a few large Thai-owned groups, TQM has been adopted mainly in foreign-owned companies within electronic sectors [1]. As TQM philosophy takes a broadly approach and its adoption can also be done in various manner, it would be interesting to learn how Thai companies adopt TQM in their companies. Since TQM is concerned with, among others, cultural change, it would be beneficial for Thai industry to know how Thai organisational culture affects TQM implementation and vice versa. The objective of this theme of the research is to investigate TQM implementation and approaches in Thai industry. The research focuses on the critical success factors as well as the difficulties of TQM implementation in Thai industry.

### **Defining TQM**

There are many interpretations of TQM and numerous approaches by which it can be implemented. Most definitions of TQM aim to provide management best practice. Quality gurus are sources of ideas which a company can follow or adapt for their own company. There are also many publications to give the readers ideas of TQM. Table 1 provides examples of the best-known quality gurus' ideas regarding quality and TQM.



Table 1: Examples of quality gurus and publication with their quality and TQM ideas.

Author	Idea or concept of quality / TQM
W. Edwards Deming [2]	14 points for management The system of profound knowledge PDCA (plan - do - check - action) cycle
Joseph M. Juran [3]	Fitness for use Planning for quality Quality trilogy Quality spiral
Armand V. Feigenbum [4]	Total quality control (TQC) Integrated technical and managerial approach Three categories of quality costs: <ul style="list-style-type: none"> <li>• appraisal cost;</li> <li>• prevention cost; and</li> <li>• failure cost</li> </ul>
Kaoru Ishikawa [5]	Company - wide quality control (QC Circles) Cause - and - Effect (fishbone) diagram
Genichi Taguchi [6]	The quality of a product is the loss imparted to society from the time the product is shipped. Quadratic loss function Orthogonal arrays
Shigeo Shingo [7]	Poka - yoke system - 'mistake-proofing' for zero defects
Philip B. Crosby [8]	Do it right first time. Quality is defined as conformance to requirement, not as "goodness" not "elegance". The system for causing quality is prevention, not appraisal. The only performance measurement is the cost of quality. The only performance standard is zero defects.
Tom Peters [9]	Managing by wandering about (MBWA). Twelve traits of a quality revolution.

The general ideas and concept provided by gurus and publications can be applied as guidelines to implement TQM. Quality awards, for example the Malcolm Baldrige Award in the USA; the European Quality Award in Europe; and the Deming Prize in Japan, can also be used as quality assessment model to measure comparative level of quality development. The success of TQM implementation depends upon the organisation itself, how they approach TQM in their organisation; whether it is appropriate; etc. Because of the partisan and subjective nature of much of the debate about the different approaches to TQM, a theoretical framework is required in which to position the different types of implementation.

### A Theoretical Framework

The organisation needs to adopt a suitable TQM implementation and performance improvement strategy, by adopting a change model which is culturally feasible. Whittle et al [1992,11] have identified 3 generic paradigms for total quality implementation and a meta-paradigm which informs and enables movement between the 3 models:

1. The visionary model of TQ. (VTQ)
2. The planning model of TQ. (PTQ)

- 
3. The learning model of TQ. (LTQ) and
  4. The transformation model of TQ. (TTQ)

The classification of the models was produced from the literature on culture change and management theory and the inductive analysis of their research. The characteristics of each are shown in Fig. 1.

From the viewpoint of the transformational TTQ paradigm, the TQ implementation process is a cyclical process by which a company can choose the most suitable of the other models and move between them as necessary to improve quality performance. Since there is no single route for such a TQ implementation, a company should select a suitable approach of TQM for their company and implement it appropriately. At the first stage of TQM implementation, the personnel involved follow the implementation plan and will maintain a good quality performance for some time. However, after the company has gone through the TQM implementation process, it is difficult to maintain good results using the same approach due to the diminishing returns effect.

When the TQ programme based on this model falters, they can adopt the TTQ meta-perspective which allows them to break out their exist paradigm for TQ implementation and seek out another appropriate model for their company in the next stage. Whittle et al [1991,10] argued that " a concept for culture change in TQM not as the installation of a set of traits but as a continuous process of cultural renewal. ...TQM implementation is a cyclical process which consists of :

- an intense and highly structured period of intervention/activity followed by
- a period of reflection/reorientation when interventions are dissipated, experimental and relatively uncoordinated. At this stage the implementation can either stagnate and wither or take off into
- a further period of intense and structured activity to be followed by
- a return to reflection and experimentation."



Figure 1: TQ implementation models (from Whittle et al, 1992)

<p><b>1. VTQ MODEL</b> People as Programmable Pawns.</p> <p>TQ FOCUS: External customer/stakeholder</p> <p>KEY DESIGN ISSUE: Control (including cost)</p> <p>DESIGNERS: Senior Management</p> <p>IMPLEMENTATION CHARACTERISTICS: concern with ideology, mission, solutions, rules and prescriptions, codes of conduct, order, faith, role of "leaders".</p> <p>IMPLEMENTATION STRATEGY: tends to be top down, focusing on training and procedures.</p>	<p><b>3. LTQ MODEL</b> People as Willing Participants.</p> <p>TQ FOCUS: Self/ Internal, Customer and Supplier.</p> <p>KEY DESIGN ISSUE: Motivation, Commitment.</p> <p>DESIGNERS: HRM/OD specialists.</p> <p>IMPLEMENTATION CHARACTERISTICS: concern with education, skill &amp; attitude development, performance appraisal, reward &amp; recognition, natural work teams, symbols, style.</p> <p>IMPLEMENTATION STRATEGY: tends to be bottom - up, attitudinal and involvement focused.</p>
<p><b>2. PTQ MODEL</b> People as Productive Resources.</p> <p>TQ FOCUS: On Competitors and Resource Suppliers.</p> <p>KEY DESIGN ISSUE: Integration.</p> <p>DESIGNERS: Technologists, systems analysts, specialist support staff.</p> <p>IMPLEMENTATION CHARACTERISTICS: concern with process regulation, boundaries, specification, information, measurement, value, simplicity, waste, benchmarking, project teams.</p> <p>IMPLEMENTATION STRATEGY: tends to be off - line, measurement and technology driven.</p>	<p><b>4. TTQ MODEL</b> People as Purposive Agents.</p> <p>TQ FOCUS: Management.</p> <p>KEY DESIGN ISSUE: Innovation.</p> <p>DESIGNERS: External Consultants.</p> <p>IMPLEMENTATION CHARACTERISTICS: concern with reframing, coaching, paradigm auditing, empowerment, partnerships, communication</p> <p>IMPLEMENTATION STRATEGY: tends to be experimental, cost effective, driven by advocacy.</p>

The above models will be used as a theoretical framework to investigate Thai companies which have been implementing TQM for a period of time. The data will be collected throughout the companies as well as the key elements derived from the theoretical framework. The data collected will be analysed to find out how Thai companies adopted TQM in their companies.

The following questions are addressed as a guideline to find out how Thai companies adopted TQM concept in their organisations:

Questions	Interviewee	Finding expected
1. What are the reasons for TQM adoption? <ul style="list-style-type: none"> <li>• Business goal and strategy</li> </ul>	Top mgt.	TQ focus
2. How do the companies plan and implement TQM <ul style="list-style-type: none"> <li>• Quality strategy</li> <li>• TQ implementation programme</li> <li>• Approach of TQ programme</li> <li>• Deployment of TQ programme</li> <li>• Focus of programme</li> <li>• Training programme</li> <li>• System used</li> <li>• Techniques used</li> <li>• People involvement</li> </ul>	Top mgt. Top mgt./mgt. Top mgt./mgt. Top mgt./mgt. Top mgt./mgt. Mgt. Top mgt./mgt. Top mgt./mgt. All	TQ focus Key design issue Designer Implementation characteristic Implementation strategy People as?
3. What are the key factors which they focus in order to successfully implement TQM? <ul style="list-style-type: none"> <li>• success factors</li> <li>• failure factors</li> </ul>	All All	Company culture Success or failure? People as?
4. What difficulties were encountered? <ul style="list-style-type: none"> <li>• What are the problems of implementation in all levels?</li> </ul>	All	Company culture Success or failure? People as?
5. How were these difficulties overcome? <ul style="list-style-type: none"> <li>• How do they resolve the problems in all level?</li> </ul>	All	Company culture Success or failure? People as?
6. Do they involve people in companies, customer and supplier in TQM and how? <ul style="list-style-type: none"> <li>• Do they involve people, customer, supplier and how?</li> <li>• Do they put it in TQ plan?</li> <li>• People involvement and participation</li> <li>• Customer focus?</li> <li>• Supplier relations?</li> </ul>	Top mgt./ mgt. Top mgt./ mgt. All Mgt. Mgt.	TQ focus Implementation characteristic Implementation strategy People as? Company culture
7. How does the organisation culture effect TQM implementation and vice versa (culture change)? <ul style="list-style-type: none"> <li>• Attitude of people on TQ at all levels</li> <li>• Involvement of people in TQ programme at all levels</li> <li>• Motivation to work</li> </ul>	All All All	Company culture Implementation strategy
8. How do they assess their		TQ implementation



achievement? <ul style="list-style-type: none"> <li>• Ultimate goal on TQM</li> <li>• Measurement</li> </ul>	Top mgt. Top mgt.	model
9. What benefits have been achieved?	All	TQ implementation model
10. Is the quality issue pervasive throughout the organisation? <ul style="list-style-type: none"> <li>• Attitude of people</li> <li>• What do they do regarding quality apart from their own job?</li> </ul>	All Supervisor/operator / inspector	TQ implementation model Company culture

Note : Top mgt. - Top management

Mgt.- the management who are responsible in production, quality, human resource, marketing and supplier relations

All - all level from top management, the management who are responsible in production, quality, human resource, marketing and supplier relations technical personnel such as R&D staff, quality engineer, design engineer; supervisors; shop floor operators and; bottom line inspectors

### Methodology

This is seen as empirical research which will be carried out using a case-study approach. Three Thai companies, which are American, Japanese and Thai-owned companies and have adopted TQM will be investigated. In depth interviews of people, including top management, middle management supervisors and shop floor operators, will be used as data collection method. Qualitative analysis will provide the insight into the organisations investigated.

In order to explicitly describe the research method, the work steps are enumerated, which are:

1. Contact three companies and get formal permission for research and contacted persons.
2. Make appointment with the contacted persons to do preliminary visit. The objectives of the preliminary visit are as follows:
  - to introduce and clarify the research which will be done in their companies; research objectives; and research method, etc.
  - to agree with the contacted persons about the information needed, time required and all arrangement.
3. Interview people in the organisation. The researcher aims to interview various people in different position in order to get wide perspective of people in the organisations. The target personnel are top management; the management who are responsible in production, quality, human resource, marketing and supplier

relations; technical personnel such as R&D staff, quality engineer, design engineer; supervisors; shop floor operators and; bottom line inspectors. Interviews will be recorded by tape recorder and will be transcribed to be analysed. The outline of the questions is shown in Table 2.

4. Write reports for companies.
5. Write a research paper describing the overall study.

Table 2 : Outline of questions and interviewee

Question guideline	Interviewee					
	Top mgt	Q mgt	Mgt	Tech.	Sup	Oper.
1. What is the company's business goal & strategy?	X					
2. What is the strategy on quality management?	X	X				
3. How do you approach TQ in your company?	X	X				
4. What is the motivation of your people to work?	X	X	X			
5. What is the ultimate goal of TQ in your company?	X	X				
6. How do you deploy the quality strategy?	X					
7. What is the strategic planning you use?	X	X				
8. How do you involve employees at all levels in the plan?	X					
9. What is the response from your employees?	X					
10. What are the key factors for success?	X	X	X			
11. What are the difficulties you encounter?	X	X	X		X	
12. How do you overcome them?	X	X	X		X	
13. What do you think about Thai workforce, is there any different from other countries? If so, what are the differences? And what is the impact of them on TQ programme both positive and negative aspect, and vice versa?	X	X	X			
14. How do you measure it?	X	X				
15. What is your responsibility for quality in the company?		X	X	X	X	X
16. What is the TQ programme and its focus?		X				
17. How are you involved in the TQ programme?		X	X	X	X	X
18. How has the TQ programme in your company been approached and deployed to lower level?		X	X			
19. How do you train your people?		X	X		X	
20. Explain the operating system for quality in your company?		X	X			



21. What kinds of techniques are used to improve quality?		X	X	X	X	X
22. What do you think about shop floor employees involvement to TQ programme?		X	X		X	
23. What do you think about the relationship between Thai workforce and TQ?		X	X			
24. In the TQ programme, do you have plan about customer and supplier? If so, what are those plan?	X	X	X			
25. What do you think about TQ programme?		X	X	X	X	X

Note : The questions in Table 2 will be use as guideline to interview, more questions may be asked according to the conversation during interview.

### References

1. KRASACHOL, L., TANNOCK, J.D.T., and WILLY, P.C.T 1997 The Progress of Quality Management in Thailand. Proceedings of the 2nd International Conference on ISO 9000 and Total Quality Management.
2. DEMING, W.E. 1986. Out of the Crisis : Quality, Productivity and Competitive Position. Interfaces, 5 (No.4)
3. JURAN, J.M. 1988. Quality Control Handbook 4 rd Edition. New York, McGraw - Hill.
4. FEIGENBUM, A.V. 1983. Total Quality Control - 3 rd Edition. New York, McGraw - Hill.
5. ISHIKAWA, K. 1985. What is Total Quality Control? The Japanese Way. Prentice hall, Engelwood Cliffs, New Jersey.
6. TAGUCHI, G. 1986. Introduction to Quality Engineering. Asian Production Centre, Tokyo.
7. SHINGO, S. 1986, Zero Quality Control: Source Inspection and the Poka - yoke System, (trans). Cambridge Ma, Productivity Press.
8. CROSBY, P.B. 1979. Quality is Free. New York, McGraw - Hill.
9. PETER, T.J. 1982. In Search of Excellence. Harper & Row.
10. WHITTLE, S., SMITH, S., TRANFIELD, D. FOSTER, M. 1991. Implementation Total Quality: Erecting Tents or Building Palaces. 6th International Conference of OMA (UK) 1991.
11. WHITTLE, S., SMITH, S. TRANFIELD, D., FOSTER, M. 1992. Total Quality and Change Management: Integrating approaches for Organisation Design. Institute of Electrical Engineers Third International Conference, York, July 1992.

**Appendix 7: Core phrases from TQM interviews**



**Table 1 Phrases indicative of particular model in case study**

Model	Whittle et al's [9]	SRJC's	TPT's	RRT's
VTQ Phrase	<p>Clear company mission or goal</p> <p>Awareness training for all</p> <p>Companywide communication</p> <p>Appointment of TQM co-ordinator/facilitator</p> <p>Increased market share/profit</p> <p>Senior Management Commitment</p>	<p>Appoint TQC promotion manager</p> <p>TQC is a tool to help company to work in planning for the future</p> <p>Senior management training by consultant in Japan</p> <p>Learning from Japanese consultants</p> <p>Measure the performance comparing to set target and ensure that the implementation plan was followed (not deviate from control plan)</p> <p>Follow up the implementation by management and company meeting</p> <p>Increase market share</p> <p>New product development</p> <p>MD policy</p> <p>Mission of SRJC is to be the top five in refractory industry</p> <p>Management has to motivate and pay attention to their subordinates</p> <p>Quality and production system promotion section is responsible for co-ordination of non-routine quality work</p>	<p>Information from customers is the most important but we receive feed back through head office in Japan</p> <p>Product development</p> <p>Management by objectives</p> <p>Training new employees</p> <p>Top-down policy to maintain 5-S</p> <p>Top management commitment</p>	<p>Clear company mission</p> <p>Training all employees</p> <p>Cascade training</p> <p>Appoint TQM manager</p> <p>Training development system</p> <p>100% awareness training</p> <p>Customer survey</p> <p>Clear company direction</p> <p>Training new staff</p>

		<p>Market in concept  Management by fact  Increase sale  Every productivity improvement activity is led by management  Clear company vision  The function of quality and production system promotion section is to guide and provide "quality" knowledge  TQC is a tool for management  Establish company vision by top management  Establish company vision by top management  Change behaviour from KKD to management by fact  Catchball meeting  QCC must support company goal  Training all employees  Management commitment  Policy deployment from management by action plan  policy from executive management to improve quality  TQC is top-down activity</p>		
--	--	---	--	--



		Top management supports TQM activities continuously		
VTQ to LTQ	N/A	Measure co-operation of employees Management must communicate and educate their subordinates There is committee to be in charge of QCC Reward system to motivate employees	Cascade communication from top to bottom to cultivate good attitude	N/A
VTQ to PTQ	N/A	Management learns to use problem solving techniques from consultant	N/A	Cascade training in problem solving tools and techniques for non-labour staff
LTQ Phrase	Changes in attitudes/ behaviour/ morale/ lower absenteeism Employee participation/ ownership/ empowerment Multi-skilling/ flexible working practices/ devolved authority Improved safety/ working conditions Individual employee development/ education Quality based reward system	Reward and recognise "the excellent QC group" Quality control circle (QCC) 5-S Safety Suggestion system Employee participation PDCA cycle We are in the stage of making company wide (in TQM implementation) Reward employees Not only QA but also production	It is manufacturing department responsibility to produce only good product Reward system Recognise and send the excellent employees to Japan Employee participation is very important for quality improvement QCC group Abnormal situation report Suggestion system TP (Total Productivity) TPM (Total Productive	Quality of employees TQM is part of appraisal review Reward and punishment as employee motivation TQM is every day life Performance appraisal TQM implementing focus on changing employee behaviour Employee participation Suggestion system Reduce absenteeism Total participation

		<p>and maintenance are involved in quality improvement</p> <p>Human resource is critical factor for TQC</p>	<p>Maintenance)</p> <p>5-S</p> <p>Safety</p> <p>Reward system</p> <p>Involvement of employee is part of performance appraisal system</p> <p>Foster good attitude towards quality among employees</p> <p>Encourage " natural team work" environment</p> <p>It is company policy to work as team</p> <p>Employee empowerment</p> <p>Employee involvement</p> <p>Long term employment</p> <p>Human resource is responsible for training</p> <p>Quality of employees is important to produce quality product</p> <p>Management and technique training for employees</p> <p>Employment development</p> <p>Low absenteeism</p> <p>Life time employment</p> <p>Sense of belonging of employees</p> <p>Morning meeting</p>	<p>Appraisal review</p> <p>Reward system</p> <p>Recognition system</p> <p>Sense of belonging</p> <p>Good attitude of employees</p> <p>Good working environment</p>
--	--	---	--	--



PTQ Phrase	<p>Use of problem solving tools/ teams</p> <p>Continuous improvement/ Defects prevention</p> <p>Management suppliers to meet requirements</p> <p>Measure and monitor performance through SPC, audits</p> <p>Increased productivity/efficiency/product quality</p> <p>Reduction in waste/ non-conformance/ CoQ/ lead times</p>	<p>Cost reduction</p> <p>We use QC tools and advance QC tools</p> <p>Management supplier through ISO 9000 system, specification and work instruction</p> <p>Implementing ISO 9000</p> <p>All employee QC tools training</p> <p>Use QC story</p> <p>Use problem solving tools</p> <p>TQC implementation focus on production</p>	<p>Quality meeting every month</p> <p>Brainstorm among operators and leader to improve quality working as a team</p> <p>Good working environment</p> <p>Employees pride of their work</p> <p>Performance appraisal</p> <p>Educate employees</p> <p>Recognition system</p> <p>Good working condition</p>	<p>Strong system in company</p> <p>Use new technology (Just in time technology)</p> <p>Satisfy customer by establishing "customer technical service group"</p> <p>Set up quality system using ISO 9000</p> <p>Use "project team" to improve system</p> <p>Senior/executive management support and provide resources as well as encourage employee (activity) continuously</p> <p>Cost reduction</p> <p>Project team must use 7 steps</p> <p>Increase efficiency</p>
------------	---	--	---	---

				<p>Work as a team (in operation) using systematic way by learning from feedback</p> <p>Management of supplier by providing "supplier quality engineer" to work with</p> <p>Set up 3 year TQM programme</p> <p>Use various media including "share folder network" to promote TQM programme</p> <p>Project team</p> <p>Organise regular training courses for engineer and technician to solve problems of their work</p> <p>Develop system (software) through Kiosks for front line operators to re-certify themselves</p> <p>System audit by implementing ISO 9000</p> <p>TQM on-line system</p> <p>Use internal customer/supplier concept</p> <p>Use 7 steps</p> <p>cost saving</p> <p>Quality improvement</p> <p>Just in time manufacturing process</p> <p>TQM project activity is break</p>
--	--	--	--	---



				<p>through project for continuous improvement (not routine work)</p> <p>Management support, provide resources and encourage employees to participate in TQM activity</p> <p>Improve product quality</p> <p>TQM activity mainly in manufacturing</p> <p>Monitor supplier and development (SBR: supplier business service)</p> <p>Use problem solving tools</p> <p>Reduce waste</p> <p>Use Kiosks to learn specification</p> <p>Just in time Technology</p> <p>Work instructions and procedures</p> <p>Supervisor is leader of TQM team and select the representative of operator/inspector to be member of project team</p>
PTQ to VTQ	N/A	Use problem solving techniques lead by management	N/A	N/A
	<p>Open mindedness/ readiness for change</p> <p>Strategic leadership/ senior management review</p> <p>Challenge traditional views and</p>	N/A	N/A	N/A
TTQ Phrase				

	<p><b>activities</b></p> <p>Apply the lessons of those who have successfully implemented TQ</p> <p>Breakdown barriers/ question practices</p> <p>Clear and review implementation</p>			
--	--	--	--	--



**Appendix 8: Permission letters from collaborating companies**



บริษัท สยามอุตสาหกรรมวัสดุทนไฟ จำกัด  
THE SIAM REFRACTORY INDUSTRY CO.,LTD.

January 23, 1998

Khun Ladawan Krasachol

PhD Student

University Park

Nottingham NG7 2RD

Dear Khun Ladawan,

Thanks for your draft report of the study that you send me . In my point of view, there are no comments on your report.

As a result of our company improvement, may you possibly let us know your valuable comments after you finished your Ph.D. Thesis. Furthermore, we would like to inform you that we would be never mind if you will mention our company's name in connection with the information given in your report.

We would be appreciated with your contact, and we hope that we can take part to help you.

Best regards,

Marut Mangklabruks

Managing Director



QCS-LT-8001

16<sup>th</sup> February, 1998

Dear Ms.Ladawan krasachol  
PhD. Student

With regard to yours of 13<sup>th</sup> ultimo. We have much pleasure to announce you that we allow you to mention our company's name in connection with the details in your thesis and also in academic publication as your special request.

We feel highly honored by your trust, and hopefully it will be helpful to make a success in the part of your thesis.

Sincerely yours,



Mr. Tsuyoshi Umeda  
Asst. General Manager of (Q/P)Gr.

February 05, 1998

Ladawan Krasachol  
PhD Student  
University of Nottingham  
University Park  
Nottingham, NG7 2RD  
England

Dear Ms. Ladawan,

After reviewed the draft report, A study of Total Quality Management implementation in Thailand, on the study of The Read-Rite (Thailand) Co., Ltd. it's all right to mention the company name in connection with the information given in the report only for your thesis and/ or academic publication purposes.

Yours sincerely,



Tawan Supapunt  
VP/GM  
Read-Rite (Thailand) Co., Ltd.

CC: Somnuck Wiroonpong



**Appendix 9: Summary report on responses of commentators**

---

## Summary report on responses of commentators

TFQSS (Thai version) was sent out to ten commentators selected by NSTDA in September 1997. A brief background of TFQSS project and evaluation form was also given to them. The commentators were requested to comment on four elements of TFQSS separately. However, they were able to add more elements including any other comment if they wanted. The project facilitator received completed evaluation forms from eight commentators, which were summarised in the following section.

Three commentators are university lecturers. Four are professional quality consultants and the other is a manager in a manufacturing company. Those who are not working as professional consultants also provide consultancy service to companies on a part time basis.

### Academic Commentators

#### *Person 1*

##### Main Idea:

- Use “organisation” instead of “company”
- Provide flow chart for the organisation to demonstrate relationship between general process and TFQSS requirements.
- Identify type and level of documents to be used such as quality manual, quality procedure, work instruction, etc.
- Provide example of each document.
- Provide the preparation for adopting quality system.
- Provide practical method.
- Add section 5. Quality system audit and review.
- How to apply for TFQSS certification?

##### Comment on elements

#### 1. Quality Objectives

The *organisation* must identify and document its quality objectives. Quality objectives are the aims of the *organisation* as regards the quality of the goods and/or services which it *wants* to supply.

#### 2. Planning for Quality

##### 2.1 Product and Service Quality Specification

The documentation.....etc. The specification must be indicate the acceptance criteria for the quality control system to indicate what is acceptable for each quality *as well as to be convenient for product traceability*.

##### 2.2 Planning the Process

Comment is about language concern.

---



## 2.3 Staff

### add 2.3.X Staff Recruitment

The organisation should establish annual training plan and maintain training records.

## 2.4 Document and Data Control

All the quality planning documents must be controlled, to ensure that only the correct and *updated* version is in use.

Records about all important quality matters must be maintained for a specified period. *Those quality records which reach specified time should be reviewed and finally abolished.*

## 2.5 Product and Material Care - Should include product traceability

## 3. Quality Control System

### 3.1 Checking to Quality Specification

The product and/or service specification indicates all the quality features which are important to quality. *The product and/or service specifications must be documented and reviewed to ensure that they meet customer requirements.*

### 3.2 Control of Quality Rejects - Comment is about language concern.

### 3.3 Process Control

Process control may involve *maintenance* and adjustments to the factors which influence the process.

### 3.4 Corrective Action and Quality Improvement

Both corrective action and quality improvement can be aimed at the process, equipment, material, staff and suppliers etc. *The records of corrective action and quality improvement must be maintained.*

## 4. Supplier - Use "Vendor" or "Sub-contractor" instead of "Supplier".

### *Person 2*

#### Main Idea:

- TFQSS should be written in ISO 9001 format but it should be simpler so that small businesses are able to achieve and use TFQSS as a basic step for ISO 9000.
- Language used in standard should be short and clear.
- Guideline, manual and example should be provided.
- How is TFQSS acceptable? And how to evaluate a company?
- Example should be clearly distinct from requirements in the standard (use different font or size).
- In table of the comparison of TFQSS and ISO 9000 system elements, The elements of ISO 9000 should be more than what is shown:

- ⇒ 2.3 = 4.18 (apart from 4.1.2.1)
- ⇒ 2.4 = 4.16 (apart from 4.5)
- ⇒ 3.1 = 4.16 (apart from 4.10, 4.11, 4.12)
- ⇒ 3.2 = 4.16 (apart from 4.13)

### Comment on elements

#### 1. Quality Objectives

TFQSS should define who is responsible to identify and review quality objectives.

..... so as to ensure their continuing relevance to the business and its environment **by comparing its performance and targets.**

#### 2. Planning for Quality

##### 2.1 Product and Service Quality Specification

These are **minimum specification of the products and/or services.**

##### 2.2 Planning the Process - Comment is about language concern.

##### 2.3 Staff

The authority and responsibility for quality of all staff must be defined and documented in the job description for each key position **affecting quality.**

##### 2.4 Document and Data Control - This element includes "quality records".

##### 2.5 Product and Material Care

**Handling, storage, packaging, preservations and delivery** should be documented.

#### 3. Quality Control System

##### 3.1 Checking to Quality Specification

Testing and inspection tasks, **calibration and control of measuring, inspection and test equipment must** be documented in the process plan (*see section 2.2*).

##### 3.2 Control of Quality Rejects

Use "defects" or "non-conforming products/services" instead of "rejects".

##### 3.3 Process Control

Should add "maintenance of equipment and/or machine" and working environment because small businesses always ignore these matters.

##### 3.4 Corrective Action and Quality Improvement

Prevention is part of improvement but is not identical.

#### 4. Supplier



- 
- Why must incoming goods checking to quality specifications be instituted where problems are experienced with supplier materials?
  - The company must control quality rejects of supplier.
  - "Refer to section 3.2" is not enough because control of supplied material may need "claim" or "return" etc.

### *Person 3*

#### Main Idea:

- The requirements of TFGSS are adequate to be a basic quality system. Internal audit and quality records may be useful.
- There should be definition of some specific words such as "rejects", "master list", etc.
- There should be an example in each element.
- There should be an example of corrective action plan.

#### Comment on elements

##### 1. Quality Objectives

Add "*Quality objectives should be clearly explained to all staff in order that they understand and accept the quality objectives to be their aims for work at all time.*"

##### 2. Planning for Quality

2.1 Product and Service Quality Specification - Comment is about language concern.

2.2 Planning the Process - Comment is about language concern.

##### 2.3 Staff

2.3.3 Training should include training to resolve problems and improvement of their work.

2.4 Document and Data Control - Comment is about language concern.

2.5 Product and Material Care - Comment is about language concern.

3. Quality Control System - Comment is about language concern.

4. Supplier - Comment is about language concern.

### **Professional Consultants**

### *Person 4*

---

Main Idea:

- It should be clearer that TFQSS is either “standard” or “guideline”. If it will be used as a basic quality system, criteria to evaluate basic quality system in a company should be clearly explained.
- In TFQSS, writing style is mixed of requirements and explanation. It may confuse users what must be done and what should be done. (What should be done means that they do not need to do it.)
- “System” should not be used in section 3 Quality Control System because it may confuse users that there are small systems in a big one.
- Training should be one of main elements of TFQSS.
- It should be clearly identified in the standard that the quality system responsible person must be appointed to co-ordinate and ensure that the quality system is established and maintained.
- “Section 2.3 -2.5” should not be in “Section 2 Planning for Quality”.
- Table in Annex: 2.3 staff should add 4.18 training.

Comment on elements

## 1. Quality Objectives

- Use “Policy” instead of “Objectives”.
- Example should be in appendix.

## 2. Planning for Quality

## 2.1 Product and Service Quality Specification

Design and modification of the product or services supplied is not clearly explained. It may not be useful for SME.

2.2 Planning the Process - Comment is about language concern.

## 2.3 Staff

- Example should in appendix.
- Training should be a main item.

## 2.4 Document and Data Control

It is not clear and confusing of difference between documents and records.

## 2.5 Product and Material Care

“The documentation of correct methods of care in all these matters, as applicable, is an important part of the quality planning process.” may not be necessary.

## 3. Quality Control System

## 3.1 Checking to Quality Specification

Use “Quality Control” instead of “Quality Control System”.

3.2 Control of Quality Rejects - No comment on this element



---

3.3 Process Control - Paragraph 2 is not easy to understand.

3.4 Corrective Action and Quality Improvement  
Quality improvement may not be necessary for SME.

4. Supplier - Should be more specific.

### *Person 5*

#### Main Idea:

- The company should use external auditor to help them conduct annual audit to effectively improve their system.

#### Comment on elements

### 1. Quality Objectives

The example given in the standard is kind of policy. The quality objectives should be specific and measurable such as on time delivery, reject reduction, reduction of customer complaints, etc.

### 2. Planning for Quality

#### 2.1 Product and Service Quality Specification

Customer requirements are not only specifications but also quantity, delivery time, credit of payment, after sale service. All of these need to be identified and agreed by customer and must be documented.

2.2 Planning the Process - Comment is about language concern.

#### 2.3 Staff

The company should establish tentative training plan and maintain training records.

2.4 Document and Data Control - OK.

2.5 Product and Material Care - OK.

### 3. Quality Control System

#### 3.1 Checking to Quality Specification

- The company must establish and maintain inspection and testing of receiving, work-in process and finished products.
- The company should conduct internal audit.
- The company should review customer complaints.
- Quality performance must be reviewed by management from time to time.

3.2 Control of Quality Rejects - OK.

---

### 3.3 Process Control - OK.

### 3.4 Corrective Action and Quality Improvement

Prevention is different from improvement. Prevention is correction of potential problems which do not occur yet. Improvement focuses on "quality objectives".

Correction → Prevention → Improvement

### 4. Supplier - OK.

#### *Person 6*

#### Main Idea:

- Add more examples.
- Identify "area to address" to make it more clear.
- Should explain technical term used in the standard before content because users have different basic knowledge.

#### Comment on elements

#### 1. Quality Objectives

In the example "... to improve the quality and value of our product and services *to be competitive* to ensure that business levels and profits are increased.

#### 2. Planning for Quality

2.1 Product and Service Quality Specification - Comment is about language concern.

2.2 Planning the Process - OK.

2.3 Staff

On the job training and safety training should be included.

2.4 Document and Data Control - OK.

2.5 Product and Material Care

Example should be provided such as inventory control list, first in; first out, last in; first out.

#### 3. Quality Control System

3.1 Checking to Quality Specification

Using information of inspection and testing and fool proof should be included.

3.2 Control of Quality Rejects



---

Pollution awareness and social responsibility of the company and its staff should be included.

3.3 Process Control - OK.

3.4 Corrective Action and Quality Improvement

Quality improvement is very important for quality objectives. More details on this item should be provided.

4. Supplier - OK.

### *Person 7*

#### Main Idea:

- Documents which demonstrate working process consist of at least four types as follows: business process; work procedure (for sub process); work instructions; forms.

#### Comment on elements

1 - 4 Most of comments are about language concern.

### **Management in a Manufacturing company**

### *Person 8*

#### Main Idea:

- TFQSS is not clear in terms of standard format because requirements are not stated clearly that it must be done or it does not need to be done.
- Requirements of TFQSS are adequate to be a basic quality system standard.

#### Comment on elements

1. Quality Objectives - OK.

2. Planning for Quality

2.1 Product and Service Quality Specification - OK.

2.2 Planning the Process - OK.

2.3 Staff

2.3.1 Co-ordination of quality management must be the responsibility of *quality management co-ordinator who is appointed by the company* to ensure that the quality system is established and maintained in accordance with this standard.

2.3.2 Comment is about language concern.

---

---

2.3.3 All staff *affecting quality* must be given adequate training to .... their duties.

2.4 Document and Data Control - OK.

2.5 Product and Material Care - Comment is about language concern.

3. Quality Control System

3.1 Checking to Quality Specification

The product and/or service specification indicates all the quality features which are important to quality. *The product and/or service specifications must be documented and reviewed to ensure that they meet customer requirements.*

3.2 Control of Quality Rejects - OK.

3.3 Process Control - OK.

3.4 Corrective Action and Quality Improvement - OK.

4. Supplier - OK.



**Appendix 10: Thai Foundation Quality System Standard**

**National Science and Technology Development Agency**

# **Thai Foundation Quality System Standard**



## **Introduction**

The Thai Foundation Quality Systems Standard (TFQSS) has been developed by NSTDA in a collaborative project with five Thai companies. The standard aims to provide a model for quality management with a level and scope suitable for small and medium enterprises where certification to ISO 9000 series standards is not appropriate.

The TFQSS standard allows such businesses to start to progress in the direction of effective quality management, and improve their competitive position. It is also anticipated that certification to the standard will become a recognised and worthwhile basic indication of competency in quality management.

## **Contents**

### **1. Quality Policy and Objectives**

### **2. Planning for Quality**

- 2.1 Quality specifications
- 2.2 Process and inspection planning
- 2.3 Staff and training
- 2.4 Document data and record control
- 2.5 Product and material care

### **3. Quality Control System**

- 3.1 Checking to quality specifications
- 3.2 Control of quality rejects
- 3.3 Process control
- 3.4 Corrective action

### **4. Purchasing and Suppliers**

## 1. QUALITY POLICY AND OBJECTIVES

### *Requirement*

*The company must identify and document its quality policy and objectives.*

*Quality policy and objectives must be reviewed from time-to-time, so as to ensure their continuing relevance to the business and its environment.*

*Quality policy and objectives must be clearly explained to all staff in order that they can understand and accept the quality policy and objectives as their work aims at all times.*

---

### **Guidance**

**Quality policy** defines the aims of the overall company as regards the quality of the goods and/or services which it supplies.

**The quality objectives** flow from the quality policy and should be specific, measurable and achievable.

### **Examples of quality policy and objectives**

The quality policy of the company is to :-

Ensure customer satisfaction and continuing orders by supplying only products and/or services which meet the specification agreed with the customer

*and*

To improve the quality and value of our products and/or services above those of our competitors to ensure that business levels and profits are increased.

The quality objectives of the company in the current year are as follows:-

1. 50% reduction in customer complaints
2. 10% reduction in manufacturing quality rejects



## 2. PLANNING FOR QUALITY

### *Requirement*

*The company must carry out quality planning to achieve its quality policy and objectives. Plans are required in the following areas:-*

#### **2.1 Quality specifications**

- *Quality specifications for each product and/or service must be identified and documented.*
- *The acceptable tolerance limits for each of the quality specifications must be identified and documented.*
- *Where the company is responsible for the initial design or any modification of a product and/or service supplied, all statutory and regulatory requirements, including product liability, must be identified and documented.*

#### **2.2 Process and inspection planning**

- *All processes to produce or deliver the product and/or service must be identified and documented in the form of work instructions and distributed to ensure that the correct methods are known to all staff.*
- *Test and inspection plans must be established and distributed to ensure that the product and/or service conforms to specification.*

#### **2.3 Staff and training**

- *Co-ordination of quality management must be the responsibility of a specified member of the company staff who will ensure that the quality system is established and maintained in accordance with this standard.*
- *The authority and responsibility for quality of all staff must be defined and documented in the job description for each key position.*
- *All staff must be given adequate training to ensure that they are capable of achieving the required quality in their work.*

#### **2.4 Document, data and record control**

- *All the quality planning documents and data must be controlled, to ensure that only the correct version is in use.*
- *Records about all important quality matters must be maintained for a specified period.*

#### **2.5 Product and material care**

- *Product and material must be in controlled and kept in good conditions to prevent damage or deterioration.*

---

### **Guidance**

Quality planning is vital to successful quality management. Before full control can be established the planning task must be completed. Many businesses do not



document all necessary aspects of their plans for quality. The quality planning task consists of the following 5 elements:

**Quality specifications.** The company should identify all the significant quality features which are important to the customer. These are the customer requirements. The customer requirements for each product and/or service should be transformed into quality specifications. These may include matters like delivery time, dimensions, after-sales service, freshness, weight, colour, taste, payment methods etc.

The documentation of quality specification may take many forms, such as engineering drawings, written descriptions of a service, etc. The specifications should clearly indicate the tolerances, which are the acceptance criteria for the quality control system to indicate what is acceptable for each quality feature.

The product or service specifications should be reviewed at appropriate intervals to ensure that they continue to meet customer requirements.

**Process and inspection planning.** The work instructions consist of appropriate descriptions of the sequence of operations which produce or deliver the product and/or service to the customer. The work instructions may take many forms such as flowcharts, pictures, written descriptions, etc. Operations may require the use of equipment or facilities, which should be defined. For example, all production machine settings for each different product must be written down and made available to the staff responsible for production.

Where test and inspection operations are necessary to check that quality specifications are met at any stage of the process, these should be included in the inspection plan. The test and inspection task should be planned and performed to identify any non-conformance to the product and/or service specifications at the earliest possible stage of the process. This will avoid waste.

**Staffing and training.** The quality co-ordinator should be a person who has sufficient authority to control the operation and ensure the effectiveness of the quality system.

The job description for each role including managers, supervisors, inspectors, process operators, clerical workers and all staff dealing with customers should clearly state the authority and responsibility for quality for that position.

Training of staff is essential to achieve quality. The organisation should establish and document an annual training plan and maintain training records. Apart from on-the-job training, the company should consider the provision of training programmes for quality problem solving and continuous improvement.

**Example of job description.** The typical responsibilities of a process operator might be:

- a) To ensure that the process plan is followed at all times and to inspect each product manufactured to check it meets the specification in all respects.
- b) To clearly identify any non-conforming products and to rework them if possible to achieve the specification.



c) To immediately bring to the attention of the production manager any defects of equipment, material or process which may effect quality.'

### Document, data and record control

The company should identify documents, data used in and records resulting from its quality system by establishing a master list of all quality document, data and records.

To ensure that only the correct version is in use, the company should identify each document with the date, author's name, a version number and an issue status. See this document for an example.

Quality records might include as applicable:-

- Inspection and test results.
- Quality rejects (including scrapped and reworked products).
- Customer complaints.
- Training records.
- Supplier quality performance records.
- Measurement and test equipment calibration records

**Product and Material Care.** Proper handling, storage, packaging, preservation and delivery are vital to ensure that the customer receives products of the required quality. Raw materials and components may also be damaged or deteriorate without proper care. Product and material care should be documented. Formal inventory control methods may be required.

The documentation of the correct methods of care in all these matters, as applicable, is an important part of the quality planning process. Any quality problems caused by inadequate product care should be treated in the same way as those caused by processing or supplier quality problems (see Section 3).

### 3. QUALITY CONTROL SYSTEM

#### *Requirement*

*The company must adopt a quality control system to implement effective procedures for:-*

#### **3.1 Checking to Quality Specifications**

- *Products and/or services must be checked by the planned test or inspection methods to ensure that they meet all quality specifications.*
- *Whether or not any product, service and/or material has been checked must be clearly marked and identified at all process stages.*
- *Equipment used for test and inspection must be calibrated or otherwise validated at appropriate intervals.*

#### **3.2 Control of Quality Rejects**

- *Any product or material which is found to be reject (non-conforming to quality specifications) must be immediately identified, marked and separated from conforming products or materials.*
- *The person responsible for authorising disposition of reject products must sign the reject record and indicate in writing the required alternative.*
- *A record must be kept of any quality rejects, including the number, type and fault(s) identified.*

#### **3.3 Process Control**

- *The company must ensure that the process is in control at all time by providing adequate training for operators as well as production equipment monitoring and maintenance where appropriate.*
- *Work instructions and quality specifications must be made available to concerned staff.*

#### **3.4 Corrective Action**

- *Corrective action must be taken to eliminate the causes of the problem when rejects or customer complaints occur.*

---

#### **Guidance**

The heart of quality management is the control and improvement of product and service quality. This is the everyday management task based on the planning operations described in Section 2. Without proper planning quality control cannot be effective. It is *recommended* that internal audit of the quality system is instituted on a regular basis to ensure that procedures and records described below are properly implemented and maintained.

**Checking to Quality Specifications.** The product and/or service specifications indicate all the quality features which are important to quality and will be checked to ensure that they meet these specifications. Products and/or services which are non-conforming to these specifications are rejects. The method and frequency of



checking depends on the type of product and/or service. Some products require testing and inspection of every part, while others require careful control of the manufacturing process. Many service operations are difficult to check directly, and the company must depend largely on customer feedback.

The inspection and test results should be recorded immediately and placed with the quality records. Information required for process control or reject control should be immediately made available to the staff responsible.

Any equipment used for test and inspection should be suitable for the task. Instruments which require calibration to achieve proper accuracy should be calibrated at appropriate intervals and calibration records maintained.

**Control of Quality Rejects.** The quality rejects should not be passed to the customer or returned to normal use without proper authority from the staff responsible for this matter. Options for the disposition of quality rejects may include:-

- Scrap
- Rework or repair
- Pass as acceptable to specifications
- Pass as lower grade

The disposition method chosen by the responsible member of staff should be guided by the company quality policy and objectives.

**Process Control.** Where hand working such as sewing or assembly is important, the operator should be directly responsible for process control. To ensure that the operator is able to control the process, operators should be selected and trained to achieve the required quality. Work instructions and quality specifications should be made available to them as written documents, diagrams or pictures showing good and bad work, etc. as appropriate.

Process control is also necessary when production equipment must be monitored to ensure that good quality products or components are manufactured. Process control may involve equipment maintenance and adjustments to the factors which influence the process. Process settings should be detailed in the process plan. Control may be achieved on the basis of product inspection and test information, and/or process information such as temperature, pressure, etc.

**Corrective Action.** A written Corrective Action Plan should be established to deal with any persistent or severe quality problem. This plan should indicate the nature and cause of the problem and a time-scale for corrective action including a review date. If possible the required action to eliminate the cause of the problem should be clearly identified. A member of staff should be identified in the plan and made responsible for carrying out the plan in the required time-scale. Corrective action can be aimed at the process, equipment, material, staff and suppliers, etc.

Prevention and quality improvement are also important. Prevention is the elimination of potential problems which have not yet occurred. Quality improvement focuses on quality objectives, and aims to reduce undesirable variation in the products and/or

services and hence eliminate non-conformance and increase customer satisfaction. Prevention and quality improvement and not required by the TFQSS, but they are highly *recommended*. It is possible to target the most serious areas for prevention and quality improvement using simple graphical techniques such as Pareto charts. The worst processes, products, suppliers, etc. can then be dealt with using the Action Plan method described. Records of prevention and quality improvement action should be maintained.



## 4. PURCHASING AND SUPPLIERS

### Requirement

*The company must identify quality specifications for the materials, components, products or services which it purchases.*

*The company must have a system to monitor supplier's quality performance.*

*The company must have a system to select suppliers on the basis of the quality of their products and/or services as well as price.*

---

### Guidance

Many quality problems are caused by the use of material (including components, products and/or services) which are unsuitable, or are themselves of low quality. The result is often to create difficulty and extra costs within the company, and complaints from the customer. This situation may be linked to price, which makes it impractical to purchase the better material.

To reduce this type of problem, the company should clearly identify quality specifications for all material which it requires to incorporate in its own products and/or services. This will enable rational ordering, and allow objective testing and inspection of incoming material for quality rejects.

The company should have a written procedure to ensure that suppliers deliver what was ordered, to the agreed specification and quantity.

Where problems are experienced with supplied material, incoming goods checking to quality specifications (Section 3.1) should be instituted to identify quality rejects. Control of quality rejects should be instituted (Section 3.2) as for goods manufactured in the company.

Quality records of all supplied material, should be kept so as to enable analysis of the performance of each supplier. Suppliers with poor quality performance may then be identified, and corrective action instituted.