

Wall, Richard J. (2008) Testing for partial agonism of the aryl hydrocarbon receptor. MSc(Res) thesis, University of Nottingham.

Access from the University of Nottingham repository:

http://eprints.nottingham.ac.uk/11002/1/Masters_project_Richard_Wall.pdf

Copyright and reuse:

The Nottingham ePrints service makes this work by researchers of the University of Nottingham available open access under the following conditions.

This article is made available under the University of Nottingham End User licence and may be reused according to the conditions of the licence. For more details see:
http://eprints.nottingham.ac.uk/end_user_agreement.pdf

A note on versions:

The version presented here may differ from the published version or from the version of record. If you wish to cite this item you are advised to consult the publisher's version. Please see the repository url above for details on accessing the published version and note that access may require a subscription.

For more information, please contact eprints@nottingham.ac.uk

**TESTING FOR PARTIAL AGONISM OF THE
ARYL HYDROCARBON RECEPTOR**

Richard J. Wall, BSc.

Thesis submitted to the University of Nottingham
for the degree of Master of Research

September 2008

Abstract

2,3,7,8-Tetrachlorodibenzo-*p*-dioxin (TCDD) is the most potent of a group of persistent organic pollutants (POPs). The aryl hydrocarbon receptor (AhR) has a high affinity for these dioxin-like compounds with activation increasing transcription of CYP1A1. The aim of this paper was to measure the agonistic and potential antagonistic effects of four of the most prevalent and potent dioxin-like agonists: 3-Methylcholanthrene (3-MC), 2,3,7,8-Tetrachlorodibenzofuran (TCDF), 2,3,4,7,8-Pentachlorodibenzofuran (PeCDF) and 3,3',4,4',5-Pentachlorobiphenyl (PCB 126), comparing them with TCDD. An example of a suspected partial agonist (DF 203) and an antagonist (CH 233191) were also assayed. A method of measurement that uses real-time PCR was calibrated to quantify the induction of CYP1A1. Potency determination for different incubation times was also investigated using 3-MC and TCDD. An increase in EC₅₀ (~40 fold) between 4 and 24 hours was observed for 3-MC, whereas a lesser difference (~4-fold) was seen with TCDD. This showed that time is a clear variable when measuring CYP1A1 induction. Four individual determinations of the potency of TCDD at inducing P4501A1 gave an average EC₅₀ = 35 pM (± 5.8 pM), demonstrating the reproducibility and reliability of the method. Successful measurement of the agonistic properties of the four compounds was characterised: 3-MC EC₅₀ = 2.3 nM (Confidence interval = 1.3 - 3.8 nM); TCDF = 5.8 nM (2.8 - 11 nM); PeCDF = 2.2 nM (1.4 - 3.4 nM); PCB 126 = 765 pM (645 - 907 pM). However, no antagonistic properties were observed demonstrating that within a TCDD containing mixture, they will have no effect on the prediction of TCDD-like toxicity. Nevertheless, the method successfully characterized antagonism in the positive control compounds, DF 203 and CH 223191.

Acknowledgements

I would like to thank Dr David Bell for all his help, enthusiasm and for never giving up. I would also like to thank Declan Brady and the other members of the Bell Lab for their support and advice. A special thank you goes to Chloe Budd for making the year in the lab so much more enjoyable and entertaining.

I would like to thank my parents for giving me the opportunity to do this MRes and for supporting me, not only this year, but throughout my life for which I am truly grateful.

Finally, I would like to thank Maeve Smyth and all of my friends from Broadgate Park for an unforgettable year in Nottingham.

Table of Contents

Abstract	i
Acknowledgements	ii
Table of Contents	iii
List of Figures	v
List of Tables.....	vi
Abbreviations	vii
1. Introduction	1
1.1 AhR-ligand dependant transcription of CYP1A1	1
1.1.1 Aryl Hydrocarbon Receptor (AhR).....	1
1.1.2 Cytochrome P450 and CYP1A1.....	2
1.1.3 Activation of AhR-mediated events	3
1.2 Ligands of AhR and Agonism.....	5
1.2.2 AhR agonists	7
1.2.2.1 2,3,7,8-Tetrachlorodibenzo- <i>p</i> -dioxin (TCDD).....	7
1.2.2.2 3-Methylcholanthrene (3-MC)	8
1.2.2.3 2,3,7,8-Tetrachlorodibenzofuran (TCDF) and 2,3,4,7,8- Pentachlorodibenzofuran (PeCDF)	9
1.2.2.4 3,3',4,4',5-Pentachlorobiphenyl (PCB 126).....	10
1.2.3 AhR Partial Agonists and Antagonists.....	11
1.2.3.1 DF 203	11
1.2.3.2 CH 223191	12
1.3 Human Health.....	13
1.3.1 Persistent Organic Pollutants.....	13
1.3.2 Toxic Equivalency Factors	13
1.3.3 Limitations of TEQ predictive method	15
1.4 Measurement of AhR activation.....	19
1.4.1 CYP1A1 Induction	19
1.4.2 Measurement of CYP1A1 RNA by Real-Time PCR.....	20
2. Method.....	22
2.1 Reagents	22
2.1.1 Cell Culture Chemicals	22
2.1.2 Kits and Reagents	22
2.1.3 Compounds and Solutions.....	23
2.1.4 Solutions, Buffers and Medium.....	24
2.2 Measurement of CYP1A1 induction	26
2.2.1 Cell culture	26
2.2.1.1 Cell growth curve	26
2.2.1.2 Maintenance	26
2.2.1.3 Treatment.....	26
2.2.2 RNA purification	29
2.2.3 cDNA Synthesis	30
2.2.4 Quantitative Real-Time PCR.....	31
2.2.4.1 Methodology	31
2.2.4.2 Probes and Primers.....	31
2.2.4.3 RT-PCR Efficiency	32
2.2.4.4 Measurement of CYP1A1 induction	33

2.2.5 Qbase and Graph Software.....	34
3. Results	36
3.1 Cell Growth Curve	36
3.2 CYP1A1 Induction - Method Calibration	36
3.2.1 Methodology	36
3.2.3 Method calibration using TCDD.....	37
3.3 Partial Agonism Assays.....	45
3.3.1 Methodology	45
3.3.2 3-Methylcholanthrene (3-MC)	45
3.3.3 2,3,7,8-Tetrachlorodibenzofuran (TCDF).....	48
3.3.4 2,3,4,7,8-Pentachlorodibenzofuran (PeCDF).....	50
3.3.5 3,3',4,4',5- Pentachlorobiphenyl (PCB 126).....	52
3.3.6 2-(4-Amino-3-Methylphenyl)-Benzothiazole (DF 203)	54
3.3.7 CH 223191	57
3.4 The Effect of Time of Exposure on Induction of CYP1A1 RNA.....	60
3.4.1 Methodology	60
3.4.2 3-Methylcholanthrene	60
3.4.3 Tetrachlorodibenzo- <i>p</i> -dioxin.....	62
4. Discussion	64
4.1 Measurement of CYP1A1	64
4.1.1 The Use of the H4-IIE Bioassay.....	64
4.1.2 CYP1A1 mRNA vs. EROD Enzyme Analysis	64
4.1.3 Reliability of Data	66
4.2 Partial Agonism studies.....	67
4.2.1 Agonist Properties	67
4.2.2 Comparison of EC ₅₀ with Previous Literature	67
4.2.2.1 TCDD, 3-MC and DF 203.....	68
4.2.2.2 TCDF and PeCDF	69
4.2.2.3 PCB 126	70
4.2.3 Effects of Partial Agonism on CYP1A1 RNA Induction.....	71
4.2.4 Partial agonism by DF 203	72
4.2.5 Antagonistic properties of CH 223191.....	73
4.3 Time Dependent Induction Assays.....	74
4.3.1 3-Methylcholanthrene vs. 2,3,7,8-Tetrachlorodibenzo- <i>p</i> -dioxin.....	74
4.4 Bioassay Limitations and Future Use.....	77
4.4.1 Limitations of assays	77
4.4.2 Future application of bioassay.....	78
4.5 Conclusion.....	78
References	80

List of Figures

Figure 1.1: Domain structure of AhR.....	1
Figure 1.2: The mechanism of ligand activated AhR transcription.	4
Figure 1.3: Chemical formula for TCDD.....	7
Figure 1.4: Chemical formula for 3-MC.....	9
Figure 1.5: Chemical formula for PeCDF and TCDF.....	10
Figure 1.6: Chemical formula for PCB 126.....	11
Figure 1.7: Chemical formula for DF 203.....	12
Figure 1.8: Chemical formula for CH 223191.....	12
Figure 3.1: Cell Growth Curve for H4-IIIEC3.....	36
Figure 3.2: Agarose gel showing RNA.....	37
Figure 3.3: PCR efficiency for CYP1A1, β -Actin and AhR.....	39
Figure 3.4: RT-PCR Amplification plots.....	41
Figure 3.5: Induction of CYP1A1 RNA by TCDD.....	42
Figure 3.6: Confirmation of no induction by AhR or β -Actin RNA by TCDD....	43
Figure 3.7: Comparison of Four Separate TCDD D/R Curves.....	44
Figure 3.8: Induction of CYP1A1 RNA by 3-MC.....	46
Figure 3.9: Induction of CYP1A1 RNA by TCDD with 300 pM 3-MC.....	47
Figure 3.10: Induction of CYP1A1 RNA by TCDF.....	48
Figure 3.11: Induction of CYP1A1 RNA by TCDD with TCDF.....	49
Figure 3.12: Induction of CYP1A1 RNA by PeCDF.....	50
Figure 3.13: Induction of CYP1A1 RNA by TCDD with 1 nM PeCDF.....	51
Figure 3.14: Induction of CYP1A1 RNA by PCB 126.....	52
Figure 3.15: Induction of CYP1A1 RNA by TCDD with PCB 126.....	53
Figure 3.16: Induction of CYP1A1 RNA by DF 203.....	54
Figure 3.17: Induction of CYP1A1 RNA by TCDD with 300 nM DF 203.....	55
Figure 3.18: Induction of CYP1A1 RNA by TCDD with 1 μ M DF 203.....	56
Figure 3.19: Induction of CYP1A1 RNA by TCDD with 300 nM CH-223191...	58
Figure 3.20: Induction of CYP1A1 RNA by TCDD with 10 μ M CH-223191.....	59
Figure 3.21: Induction of CYP1A1 RNA by 3-MC at 4 and 24 hours.....	61
Figure 3.22: Induction of CYP1A1 RNA by TCDD at 4 and 24 hours.....	62

List of Tables

Table 1.1: TEF Values.....	14
Table 2.1: Dosing concentrations.....	27
Table 2.2: Sequences of Rat Probes and Primers.....	32
Table 2.3: Quantities of reagents used for each sample.....	33
Table 4.1: Comparison of EC ₅₀ with previous literature.....	68

Abbreviations

3-MC	3-Methylcholanthrene
7-ER	7-Ethoxyresorufin
AHH	Aryl Hydrocarbon Hydroxylase
AhR	Aryl Hydrocarbon Receptor
Arnt	Aryl Hydrocarbon Receptor Nuclear Translocator
bHLH	Basic Helix-Loop-Helix
cDNA	Complementary DNA
CI	Confidence Interval
CYP1A1	Cytochrome P450 1A1
DMSO	Dimethyl Sulfoxide
DRE	Dioxin Response Element
EC ₅₀	Concentration that gives 50% of maximal response
EPA	Environmental Protection Agency
EROD	Ethoxyresorufin-O-deethylation
HAH	Halogenated Aromatic Hydrocarbon
Hsp90	90 kDa Heat shock protein
K _i	Binding Affinity
mRNA	Messenger RNA
NLS	Nuclear localization sequence
NTP	National Toxicology Program
PAH	Polycyclic Aromatic Hydrocarbon
PAS	Per, Arnt, AhR, Sim
PBDE	Polybrominated Diphenylether

PBS	Dulbecco's phosphate buffered saline
PBT	Persistent Bioaccumulative and Toxic
PCB 126	3,3',4,4',5- Pentachlorobiphenyl
PCDD	Polychlorinated dibenzo- <i>p</i> -dioxins
PCDF	Polychlorinated dibenzofuran
PeCDF	2,3,4,7,8- Pentachlorodibenzofuran
Per	Drosophila circadian rhythm protein
POP	Persistent Organic Pollutant
RT-PCR	Real-Time Polymerase Chain Reaction
Sim	Drosophila neurogenic protein
TCDD	2,3,7,8-Tetrachlorodibenzo- <i>p</i> -dioxin
TCDF	2,3,7,8-Tetrachlorodibenzofuran
TEF	Toxic equivalency factor
TEQ	Total toxic equivalency
WHO	World Health Organisation
XRE	Xenobiotic Response Element

1. Introduction

1.1 AhR-ligand dependant transcription of CYP1A1

1.1.1 Aryl Hydrocarbon Receptor (AhR)

The Aryl hydrocarbon receptor (AhR) is a ligand activated transcription factor which was first characterised by Poland and co-workers in 1976 (Poland *et al.*, 1976). The AhR regulates the expression of a whole host of genes specifically CYP1A1 and CYP1A2. AhR has a basic-helix-loop-helix (bHLH) near the N-terminus. Evidence shows the basic part is for DNA binding and the Helix-loop-helix (HLH) relates to protein-protein dimerization (Denison *et al.*, 2002; Whitlock, 1999). AhR belongs to the PAS (Per-Arnt-Sim) family of evolutionary genes which include drosophila genes; Per and Sim and the mammalian Arnt gene regions (Whitlock, 1999).

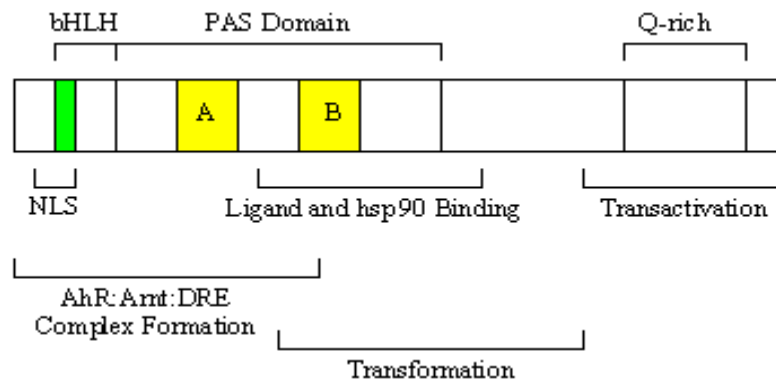

Figure 1.1: Domain structure of AhR – Adapted model of AhR structure from Denison *et al.* (2002). bHLH: basic helix-loop-helix, NLS: Nuclear localization sequence, PAS: Per-Arnt-Sim, A: Per A, B: Per B, hsp90: heat shock protein-90KDa, AhR: Aryl Hydrocarbon Receptor, Arnt: Aryl hydrocarbon Receptor Nuclear Translocator, DRE: Dioxin responsive element.

The AhR protein partner Arnt (Aryl Hydrocarbon Receptor Nuclear Translocator) is also included in this family which all have a bHLH (except Per) binding it both to the DNA and to other proteins. The precise role of each region is unknown, but together they influence protein-protein binding, DNA recognition and ligand binding (Whitlock, 1999). Further along the AhR is the C terminal segment that contains the transactivation domain. The dormant AhR is found in the cytoplasm and consists of a multi-protein complex of chaperone proteins (Denison *et al.*, 2003; Whitlock, 1993) which unbind from the AhR once it has entered the nucleus. These chaperone proteins include two chaperone proteins called hsp90 (heat shock protein-90KDa), an X-Associated protein (XAP2) and a 23KDa co-chaperone protein; p23 (Bell and Poland, 2000; Denison *et al.*, 2003). According to Bell and Poland (2000) the hsp90 may stop the unliganded Ah receptor from binding with the DNA. The AhR can be induced by both halogenated aromatic hydrocarbons (HAH) and polycyclic aromatic hydrocarbons (PAH). Induction is an adaptive response that facilitates detoxification by increasing the levels of metabolising enzymes.

1.1.2 Cytochrome P450 and CYP1A1

Cytochrome P450 is a diverse super family of hemoproteins, which in humans, can be found in the inner membrane of the mitochondria or the endoplasmic reticulum. The cytochromes metabolise thousands of endogenous and exogenous compounds and play an important role in hormone synthesis and breakdown. It is the most important element of oxidative metabolism in humans. Activation of the AhR will induce the transcription of P450 enzymes including *CYP1A1*.

CYP1 enzymes are usually involved in drug and steroid metabolism. CYP1A1 is a gene located on chromosome 15 between 15q22 and 15q24 which encodes the P450 enzyme *CYP1A1*, involved in xenobiotic and drug metabolism. Normally, *CYP1A1* has a role in xenobiotic metabolism in which it oxygenates lipophilic compounds to inactive compounds however there is evidence that shows oxidative DNA damage due to the breakdown products (Park *et al.*, 1996).

1.1.3 Activation of AhR-mediated events

The AhR is activated by specific ligands which must display binding specificity to activate the receptor. Once binding of the ligand to the AhR has occurred, the ligand-AhR complex undergoes a conformational change leading to the AhR exposing the nuclear localising sequence. The ligand-AhR complex translocates to the nucleus (Hord *et al.*, 1994; Pollenz *et al.*, 1994), where the chaperone complex unbinds from the ligand-AhR allowing the complex to bind with another protein called Arnt producing a heterodimer. Binding of the ligand-AhR complex with Arnt has been shown to increase the binding affinity for DNA (Hankinson *et al.*, 1995; Probst *et al.*, 1993; Whitlock, 1993).

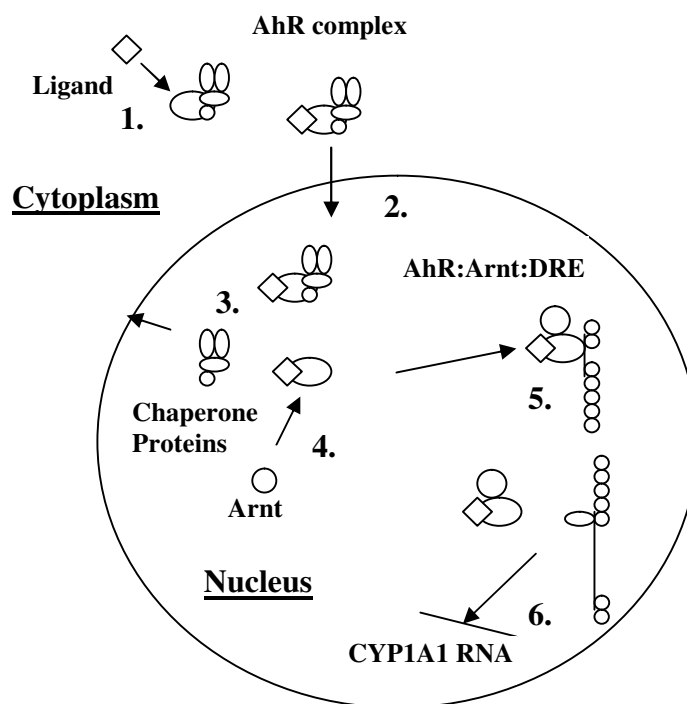

Figure 1.2: The mechanism of ligand activated AhR transcription – 1: Binding of AhR to ligand. 2: Translocation from cytoplasm to nucleus. 3: Unbinding of chaperone proteins from AhR. 4: Binding of AhR and Arnt to form heterodimer. 5: Binding of AhR:Arnt complex to DRE. 6: Transcription of CYP1A1 RNA. AhR: Aryl hydrocarbon receptor, Arnt: Aryl hydrocarbon Receptor Nuclear Translocator, DRE: Dioxin responsive element. Figure was adapted from Denison *et al.* (2003).

An enhancer is located upstream of the CYP1A1 coding region and contains multiple copies of binding sites for the AhR-Arnt heterodimer (Denison *et al.*, 1988a; Denison *et al.*, 1988b). These specific locations are known as xenobiotic- or dioxin-responsive elements (XRE or DRE) and have the sequence of 5'-TNGCGTG-3' (Denison *et al.*, 1988a; Whitlock, 1999). The more proximal control element has the functional properties of a transcriptional promoter, located immediately upstream of the CYP1A1 gene (Jones *et al.*, 1990). The promoter contains several other binding sites for other transcriptional factors but not for AhR or Arnt. The promoter contains a guanine-rich region, a TATA box and CCAAT box transcriptional factors (Whitlock, 1999). The promoter requires an

operational enhancer and all protein-DNA interactions are AhR and Arnt dependant. Therefore it has been suggested that the enhancer controls the promoter, with the prospect that the promoter attaches in some way to the AhR/Arnt complex with the enhancer via the TATA box, folding the DNA (Whitlock, 1999).

1.2 Ligands of AhR and Agonism

1.2.1 Definition of Agonism

Interactions of ligands with receptors are assumed to follow the law of mass action, with the way they interact with the receptor measured by two properties, affinity and efficacy. Affinity is the property of attraction between a ligand and the receptor, whereas efficacy is the property that allows the ligand, once bound, to produce a response (Kenakin, 1997). This allows ligands to be split into several categories of full agonists, partial agonists, antagonists and inverse agonists. Another property allowing ligands to be categorised and compared is intrinsic efficacy. Intrinsic efficacy is the measure of the stimulus per unit of drug-receptor complex (Urban *et al.*, 2007). A full agonist would have a high intrinsic efficacy whereas a competitive antagonist would have none, however the antagonist would still bind to the receptor blocking interaction with an agonist. A full agonist will produce a maximal response irrelevant of its affinity for the receptor whereas a pure antagonist won't produce any response. A partial agonist has a lower intrinsic efficacy than a full agonist and does not produce a maximal response irrelevant of the dose. It would be assumed that a full agonist would work as efficiently as the endogenous ligand for that receptor, however in the instance of the AhR, a receptor responsible for xenobiotic metabolism, the exact endogenous

ligand is unknown as the receptor binds to a large variety of ligands both synthetic and naturally occurring. Potency is the expression of the activity of the ligand in terms of concentration or the amount needed to provide an observable response (Jenkinson *et al.*, 1995). The effective dose at which provides 50% of the maximal response (EC_{50}) can be used to estimate the potency of an agonist. The lower the concentration needed for an effect, the higher the potency. TCDD is one of the most potent inducers of the AhR. A competitive antagonist will compete with the agonist for the receptor but can be overcome by increasing the concentrations of the agonist. This means the dose-response curve will shift to the right but the agonist will still have the same maximal response. Contrary to this is non-competitive antagonism where the antagonist binds at a different site from the agonist, or binding covalently to the same site and can't be overcome by increasing the concentration of agonist.

The definition of a partial agonist; is an agonist which binds with high affinity to a receptor, but activates only a small proportion of receptors hence a low efficacy. In some instances the agonist may appear to have only agonist properties but when in the presence of another compound, may also elicit antagonist effects by reducing the potency of the other compound. Schild regression analysis is a useful way of estimating the agonist or antagonistic response caused by the receptor. Using a dose response curve of the agonist in the presence and absence of various concentrations of antagonist, it is possible to calculate the potency of a partial agonist or antagonist (Calderone, 1998).

1.2.2 AhR agonists

1.2.2.1 2,3,7,8-Tetrachlorodibenzo-*p*-dioxin (TCDD)

2,3,7,8-tetrachlorodibenzo-*p*-dioxin (TCDD) is the most potent of a family of halogenated aromatic hydrocarbons (HAHs). TCDD induces a diverse spectrum of phase I and phase II drug metabolising enzymes including CYP1A1, CYP1A2 and CYP1B1, and their dependant activities, glutathione s-transferase, glucuronosyl transferase and NAD(P)H quinine oxidoreductase (Safe, 1986; Whitlock, 1993). Proteins modulated by TCDD include growth and differentiation, cytokines, xenobiotic metabolising enzymes and enzymes involved in the metabolism of fatty acids. TCDD is both highly stable and lipophilic, and is also one of the most potent known CYP1A1 inducers (Whitlock, 1993). TCDD is relatively resistant to metabolism and has a half life of 17-31 days in rats and 10 years in Humans (Van den Berg *et al.*, 1994; Whitlock, 1993).

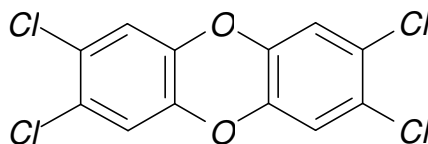

2,3,7,8-Tetrachlorodibenzo-*p*-dioxin

Figure 1.3: Chemical formula for 2,3,7,8-Tetrachlorodibenzo-*p*-dioxin (TCDD)

TCDD is absorbed primarily through the consumption of dairy and fat, where it accumulates. In animals, TCDD has differing effects with a wide range of biological effects including changes to metabolic pathways, immunological changes, teratogenic effects and neoplasia (Poland *et al.*, 1982; Safe, 1986; Walker *et al.*, 2005; Whitlock, 1993). TCDD originated as a by-product of plastic and general industrial manufacture, but its production, even unintentional, was

banned in the 1970-1980s. The TCDD levels in the environment have decreased over the last three decades but TCDD is still a much studied compound due to its much higher toxicity compared to other, more abundant environmental pollutants. One of the most notable endpoints of TCDD poisoning is Chloracne, an acne-like eruption of black heads (Tindall *et al.*, 1985). There is also evidence that TCDD causes an increased likelihood of cancer in humans (Manz *et al.*, 1991) but most research agrees that even the highest environmental background level of TCDD will not increase the initiation of cancer (Aylward *et al.*, 1996; Bertazzi *et al.*, 1989; Brown *et al.*, 1998). Furthermore, evidence suggests that TCDD is more of a promoter than an initiator, with humans being less sensitive to TCDD than animal models (Aylward *et al.*, 1996; Ema *et al.*, 1994; Harper *et al.*, 2002). During the Vietnam War, Agent Orange was a herbicide used by the Americans to remove the foliage covering the Vietnam army. The herbicide, which rapidly increases plant leaf growth before defoliating them, was a mixture of two chemicals: 2,4-dichlorophenoxyacetic acid (2,4-D) and 2,4,5-trichlorophenoxyacetic acid (2,4,5-T). However, it was later found that the herbicide contained TCDD as a by-product in the production of 2,4,5-T. Authors have found large concentrations of TCDD in milk lipid and blood samples of the people involved in the dispersal of the herbicide but have found that current levels are decreasing to that found in industrialised areas (Kahn *et al.*, 1988; Schechter *et al.*, 1995).

1.2.2.2 3-Methylcholanthrene (3-MC)

3-Methylcholanthrene (3-MC) is a polycyclic aromatic hydrocarbon produced when burning organic compounds at very high temperatures. It is a known potent

carcinogen, implicated in prostate cancer, which is used in study models as an inducer of cancer (Malins *et al.*, 2004; Sekimoto *et al.*, 2004; Wood *et al.*, 1978; Xu *et al.*, 2005).

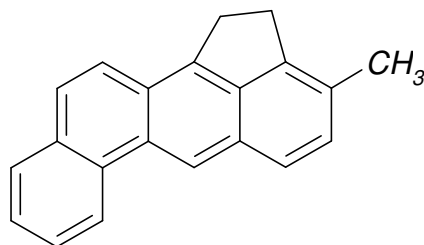

3-Methylcholanthrene

Figure 1.4: Chemical formula for 3-Methylcholanthrene (3-MC)

Poland and Glover (1974) demonstrated that 3-MC activated the AhR and induced CYP1A1. The authors also found that induction by 3-MC decreased with time, explaining this as metabolism. This has since been confirmed by other authors, although the comparison of potency and affinity with TCDD previously quoted by Poland and Glover (1974) has been considerably refined (Riddick *et al.*, 1994; Sekimoto *et al.*, 2004; Xu *et al.*, 2005). Research has shown the 3-MC has a slightly lower binding affinity (Okey *et al.*, 1982) and a lower potency (Riddick *et al.*, 1994) in comparison to TCDD.

1.2.2.3 2,3,7,8-Tetrachlorodibenzofuran (TCDF) and 2,3,4,7,8-

Pentachlorodibenzofuran (PeCDF)

2,3,7,8-Tetrachlorodibenzofuran (TCDF) and 2,3,4,7,8-Pentachlorodibenzofuran (PeCDF) are both polychlorinated dibenzofurans. TCDF is a halogenated aromatic hydrocarbon which has no known industrial use but is still widespread in the environment (Birnbaum *et al.*, 1980). Both TCDF and TCDD have a similar structure with TCDF having a slightly lower affinity for the AhR (Safe *et al.*, 1990).

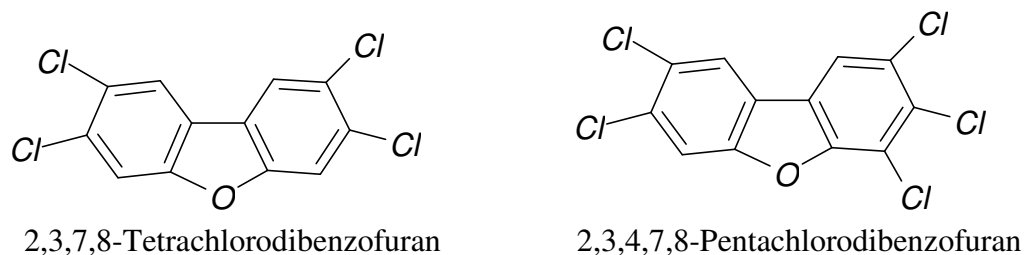
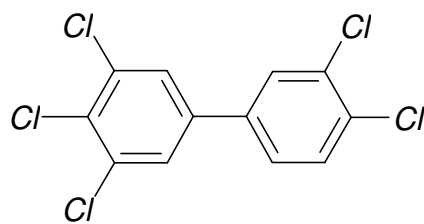

Figure 1.5: Chemical formula for 2,3,4,7,8-Pentachlorodibenzofuran (PeCDF) and 2,3,7,8-Tetrachlorodibenzofuran (TCDF).

Polychlorinated dibenzofurans (PBDFs) are often found as a by-product of PCB production although the only large scale incident of exposure was in Japan (Masuda *et al.*, 1985). Symptoms are similar to that of TCDD and include chloracne, gastrointestinal problems and fatigue. PeCDF is an important dioxin-like compound because it contributes a considerable amount to the TEQ estimation (Budinsky *et al.*, 2006). TCDF has a half-life of only 2 days in rats suggesting the compound is rapidly metabolised (Birnbaum *et al.*, 1980; Clemons *et al.*, 1997).

1.2.2.4 3,3',4,4',5-Pentachlorobiphenyl (PCB 126)

Polychlorinated biphenyls (PCBs) have the same mechanism of action as dioxin-like compounds with 3,3',4,4',5-Pentachlorobiphenyl (PCB 126) being the most potent of them. PCBs had a wide spread use until they were banned in the 1970s due to their high toxicity and ability to bioaccumulate. PCBs were used as coolants for transformers and stabilizing additives in electrical insulation, flame retardants, sealants and adhesives.



3,3',4,4',5-Pentachlorobiphenyl

Figure 1.6: Chemical formula for 3,3',4,4',5-Pentachlorobiphenyl (PCB 126)

Induction of PCB 126 is well researched estimating it to be approximately 10-fold less potent than TCDD (Peters *et al.*, 2004; Sanderson *et al.*, 1996; Silkworth *et al.*, 2005). Due to this large amount of research on PCB 126, the WHO have authorised its use as a reference compound, as an alternative to TCDD (Van den Berg *et al.*, 2006).

1.2.3 AhR Partial Agonists and Antagonists

1.2.3.1 DF 203

Also tested in this study was a putative partial agonist: 2-(4-Amino-3-Methylphenyl)Benzothiazole (DF 203). DF 203 is a synthetic anti-tumour agent (Chua *et al.*, 2000; Elferink *et al.*, 2003; Loaiza-perez *et al.*, 2002), which has known agonist properties (Bazzi, 2008; Chua *et al.*, 2000; Loaiza-perez *et al.*, 2002). However, studies by Bazzi (2008) demonstrate that the compound has a high binding affinity ($K_i = 9.9$ nM 95% CI = 5.3 - 18.17 nM) but through CYP1A1 induction assays, found that DF 203 is a weak agonist. This difference between the high binding affinity and low efficacy may indicate that DF 203 has partial agonistic/antagonistic properties.

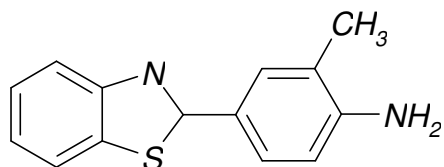

2-(4-Amino-3-Methylphenyl)Benzothiazole

Figure 1.7: Chemical formula for 2-(4-Amino-3-Methylphenyl)Benzothiazole (DF 203)

When sensitive cells are treated with DF 203, it is metabolised to 2-(4-aminophenyl-3-methylphenyl)-6-hydroxybenzothiazole (6-OH 203 or IH 130). 6-OH 203 is a potential antagonist that inhibits CYP1A1 (Bazzi, 2008).

1.2.3.2 CH 223191

As well as compounds inducing the AhR and increasing the transcription of CYP1A1, there are also compounds which inhibit induction called antagonists. One example of an AhR antagonist is 2-methyl-2H-pyrazole-3-carboxylic acid (2-methyl-4-o-tolylazo-phenyl)-amide (CH 223191) (Bazzi, 2008; Kim *et al.*, 2006).

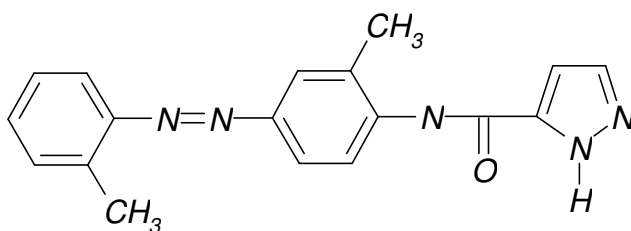

2-methyl-2H-pyrazole-3-carboxylic acid (2-methyl-4-o-tolylazo-phenyl)-amide

Figure 1.8: Chemical formula for 2-methyl-2H-pyrazole-3-carboxylic acid (2-methyl-4-o-tolylazo-phenyl)-amide (CH 223191)

Bazzi (2008) demonstrated that even at concentrations of 10 μM , CH 223191 showed no agonist effects, concluding that it was a pure antagonist. Kim *et al.*, (2006) showed that CH 223191 prevented toxic responses caused by TCDD in both *in vivo* and *in vitro* models, concluding that it could be used as a preventative

agent against TCDD-related toxicity (Kim *et al.*, 2006). TCDD, in the presence of a suitably large concentration of this compound, should have no effects on induction of CYP1A1, however at lower concentrations of CH 223191, the antagonist will have partial effects on the induction threshold but at some point the concentration of TCDD will overpower the antagonist.

1.3 Human Health

1.3.1 Persistent Organic Pollutants

Dioxins, Furans and Polychlorinated biphenyls (PCBs) are all persistent organic pollutants (POPs). Dioxins and furans have been unintentionally produced in the production industry or by incineration. It's generally accepted that these POPs all undergo a similar pathway of toxicity. The aryl hydrocarbon receptor (AhR) has a high affinity for certain dioxin-like compounds. Activation of the AhR increases the transcription of CYP1A1 which is involved in xenobiotic metabolism. 2,3,7,8-Tetrachlorodibenzo-p-dioxin (TCDD) is an agonist of the AhR and is the most characterised of the AhR ligands. Due to the complex mixtures of POPs in the environment, toxic equivalency factors (TEF) for the majority of dioxin-like compounds have been established to allow risk assessment of the toxic effects of dioxin congeners. These are calculated in relation to TCDD and can be used to determine the total toxic TCDD-equivalent dose (TEQ) (Van den Berg *et al.*, 2006).

1.3.2 Toxic Equivalency Factors

In 2005, the World Health Organisation (WHO) re-evaluated a method of estimating the toxic potency of environmental mixtures (Van den Berg *et al.*,

2006). The method involves estimating the relative effect potency (REP) for each compound which had been derived from various research studies on each chemical. At the meeting, the committee used this data to calculate the toxic equivalency factor (TEF). In the environment these AhR agonists are in complex mixtures so it is necessary to estimate the toxicity of the whole mixture. An additivity method is used which combines each individual TEF in the mixture and multiplies it with the concentration. This new value is known as the total toxic equivalency (TEQ) and is used to estimate the total TCDD-like activity of the mixture (Van den Berg *et al.*, 2006).

Congener	TEF Value
2,3,7,8-TCDD	1.0
1,2,3,7,8-PeCDD	1.0
1,2,3,6,7,8-HxCDD	0.1
OCDD	0.0003
2,3,7,8-TCDF	0.1
2,3,4,7,8-PeCDF	0.3
1,2,3,7,8-PeCDF	0.03
1,2,3,6,7,8-HxCDF	0.1
PCB 77	0.0001
PCB 81	0.0003
PCB 126	0.1
PCB 169	0.03

Table 1.1: TEF Values - Shows a selection of examples for TEF values for dioxin-like compounds (Van den Berg *et al.*, 2006).

The TEF for each compound is calculated in comparison to a reference compound, TCDD. In order for a compound to be included in the TEF system it must have a similar structural relationship to Polychlorinated dibenzo-p-dioxins (PCDDs) and undergo the same mechanism of toxicity via the AhR receptor. The

compound also needs to be persistent and show signs of biomagnification. (Van den Berg *et al.*, 2006). A database of information on REP distribution and point estimates was established by Haws *et al.* (2006). With regards to error calculation, the authors describe the method as quantitative allowing uncertainty analysis to measure the strength of the REP calculated (Haws *et al.*, 2006). The REP is calculated using dose-response curves for the agonist and TCDD. The EC₅₀ of the TCDD curve is divided by the EC₅₀ of the agonist however this system requires that the same maximum response is reached by both compounds. Further work has concentrated on how the REPs are estimated and weighted to produce the TEF. This includes problems with the data used to estimate the TEF which can be derived from different dosage methods making a large difference in the potency estimation of the TEF (Devito *et al.*, 1995). Therefore the WHO meeting concluded that a standardized method of estimating the REP was required before it can be used to further estimate the TEF. However the main issue, which will be discussed further, relates to the method of predicting the TEQ of a mixture by applying the additivity approach and factors which may affect it.

1.3.3 Limitations of TEQ predictive method

Although AhR agonists have varying potencies, it is thought that they all undergo a similar pathway of toxicity by binding to the AhR, and causing ligand-dependent induction of a gene battery (Whitlock, 1993; Wu and Whitlock, 1993). It is therefore believed that the relative potency of each compound in a mixture, in relation to concentration, can be added together to predict the potency of the full mixture. The additivity method used to calculate the TEQ, combines each individual TEF in the mixture and multiplies it with the concentration. This system

assumes that all the compounds are agonists and will have no antagonist activity in the presence of other AhR agonists. However, if an AhR agonist also has antagonistic properties, this would affect the overall toxic potency of the mixture by potentially reducing it. An evaluation of the TEF and TEQ process by the WHO stated that more research needs to be done in this area (Van den Berg *et al.*, 2006). Numerous authors have undertaken experimental analysis of the additivity approach and demonstrated the reliability of the method for risk assessment (Ahlborg *et al.*, 1994; Fattore *et al.*, 2000; Hamm *et al.*, 2003; Safe, 1990, 1994; Walker *et al.*, 1996). A more recent study into mixture characteristics was done by Walker *et al.*, (2005) assessing the TEF additivity model by assaying TCDD, PCB 126 and PeCDF, individually and in a mixture. The authors concluded that the TEQ system did not accurately predict potency but instead supported the use of a potency adjusted dose-additive approach discussed in a previous paper (Toyoshiba *et al.*, 2004). Using this method, the authors support the future use of the TEF system in cancer risk assessment (Walker *et al.*, 2005). Toyoshiba and co-workers (2004) disagreed with the additivity approach used by the WHO TEQ comparing it unfavourably against same-shape fit and simple additivity models (Toyoshiba *et al.*, 2004). They concluded that, due to differences in dose-response shape of compounds and the lack of dose additivity, the relative potency factors used to calculate the TEFs are not consistent with the WHO TEFs.

Further concerns include the use of the additivity approach for the use of dietary intake predictions. Due to the presence of naturally occurring AhR agonists and antagonists in the body, accurate prediction of TEQ becomes very complicated (Safe, 1998). An example of a naturally occurring antagonist is resveratrol (3,5,4'-trihydroxystilbene) found in red wine. According to research by Casper *et al.*,

(1999), resveratrol competes with TCDD and other AhR ligands, and inhibits the induction of CYP1A1. The antagonist binds to the AhR receptor, displacing TCDD, translocates to the nucleus and binds to the relevant enhancer site on the DNA but doesn't induce transcription of the CYP1A1 gene (Casper *et al.*, 1999). Zhang *et al.* (2003) measured the agonist/antagonist effects of several flavonoids and found that three of the compounds, kaempferol, quercetin and Luteolin, had antagonistic effects in the presence of TCDD whereas a selection of the other ligands tested had slight agonist properties including chrysin. Other examples of natural AhR ligands include bilirubin (Phelan *et al.*, 1998), indole-3-carbinol (Bjeldanes *et al.*, 1991; Gillner *et al.*, 1985), resveratrol (Casper *et al.*, 1999; Ciolino *et al.*, 1998) and flavones (Henry *et al.*, 1999).

Some mixture studies conducted have shown inconclusive results, with the authors commenting that mixtures could be additive, antagonistic or synergist, and concluded that a better understanding of mechanisms of action or the toxicokinetic behaviour was required for future predictions (Chu *et al.*, 2001; Safe, 1998). With respect to inter-species differences, Pohjanuita and co-workers (Pohjanuita *et al.*, 1995) showed the varying effects of TCDD-like compounds between different strains of rat, demonstrating a potential problem when calculating the TEF by using REPs from different strains. Furthermore, complex mixtures can contain compounds that act through different metabolic pathways and therefore the additivity approach may not always be appropriate (Safe, 1998). Another potential problem is super-induction, which occurs in a particular TCDD containing mixture, where CYP1A1 is transcribed at a higher rate than by TCDD alone although it decreases protein translation (Lussaka *et al.*, 1992, Ma *et al.*, 2000). If translation has been inhibited leading to a build up of CYP1A1 RNA, the

toxicity of a mixture could be affected, implying the predicted risk assessment TEQ maybe too high.

However, one of the leading concerns associated with the WHO TEQ additive approach is the application of the method to a mixture containing partial agonists and antagonists, which may reduce the TCDD-like effects of the mixture. Some of the most documented examples of partial agonists, from a TEQ point of view, are a selection of PCBs which have been found to have both agonistic and antagonistic properties (Clemons *et al.*, 1998; Chu *et al.*, 2001; Schmitz *et al.*, 1995; Suh *et al.*, 2003). Clemons *et al.* (1998) combined various concentrations of TCDD with different PCBs and showed that some of the PCBs had antagonistic effects which would produce a lower toxic effect than that predicted by the TEQ additivity approach. This conclusion was further complicated by the differing effects of antagonistic PCBs in complex mixtures of HAHs (Clemons *et al.*, 1998).

This paper will assay a selection of the most potent and prevalent dioxin-like AhR ligands to assess any potential antagonist properties. These include Dioxins (TCDD), Furans (TCDF and PeCDF) and PCBs (PCB 126). Also tested in this study will be a polycyclic aromatic hydrocarbon (3-MC). If antagonism/partial agonism is exhibited by any of the compounds tested in this assay, Schild regression analysis can be used to measure the potency of the antagonist. This experiment will also use an example of both a putative partial agonist (DF 203) and an antagonist (CH 223191).

1.4 Measurement of AhR activation

1.4.1 CYP1A1 Induction

The reasons that *in vitro* models were used over *in vivo* include: the ease of dosing, allowing the maximal effect to be reached at very early time points. Cells are exposed to the full concentration directly without, for example, gradual uptake from digestion or reduction by metabolism. This also means that the cells are exposed to compounds without initial metabolism by liver or bioaccumulation in adipose tissue, allowing lower doses of compounds to be used and permitting a more reliable estimation of the EC₅₀. Liver cells have a large amount of AhR in comparison to other cell types. Also taken into account, is the reduced cost and simplicity of *in vitro* models and finally the low basal CYP1A1 levels which can be easily induced. Previous confirmation of the presence of AhR in H4-IIIECE cells has been achieved (Bazzi, 2008). It is generally accepted that the most sensitive way to measure the activation of the AhR is through the measurement of CYP1A1 RNA as it is one of the most potent effects of AhR activation. The reasons that CYP1A1 induction is measured are three-fold; firstly induction is robust, with a high signal to noise ratio; secondly, induction occurs in both *in vivo* and *in vitro* models, allowing the use of cultured cells (Whitlock, 1999). Finally, induction allows genetic analysis of the mechanism of action due to the possibilities of induction-defective mutants; however this is not a required factor in this particular experiment (Whitlock, 1999).

1.4.2 Measurement of CYP1A1 RNA by Real-Time PCR

To measure partial agonism of the test compounds in this study, cells will be treated with various concentrations of TCDD with a set concentration of potential antagonist. This allows a more accurate calculation of the antagonistic properties of the test compound by measuring the shift of the dose response curve to the right. This gives more information on the compound in question compared with adjusting the concentration of antagonist and using a set concentration of TCDD. A low dose of antagonist is used so accurate calculation of the EC_{50} can be conducted while at the same time, 15% induction is large enough to be significantly different over the baseline level of CYP1A1 RNA. One of the most accurate ways of measuring mRNA is by using Real-Time PCR (RT-PCR) which gives a real time view of mRNA. This is done through the measurement of PCR cycling threshold (C_t) values, defined as the cycle in which the mRNA recorded is above a particular threshold. The C_t values are calculated for CYP1A1 and two reference genes, AhR and β -Actin, by the Mx4000 software. The PCR efficiency, which measures the efficiency of each PCR cycle, can also be calculated using this software. Further analysis using the C_t values is conducted using Qbase software. Qbase will normalise the CYP1A1 RNA C_t values against the two reference genes, AhR and β -Actin, which should be unaffected by treatment. This calculates the normalised relative amount of CYP1A1 RNA in the sample. The normalised data is then plotted on to a dose-response graph to allow comparison between different compounds using the dose that gives 50% of maximal response (EC_{50}) and its 95% confidence intervals.

Aims

Measure the agonistic and the potential antagonistic effects of 3-MC, TCDF, PeCDF and PCB 126, comparing them with TCDD. An example of a known partial agonist (DF 203) and an antagonist (CH 233191) will also be assayed.

1. Calibrate a method of accurately measuring CYP1A1 RNA using real-time PCR in H4-IIIEC3 rat liver cells.
2. Measure the induction of AhR by various agonists and partial agonists using H4-IIIEC3 cells.
3. Locate/measure any potential antagonist effects of the known agonists by combining them with various concentrations of TCDD in H4-IIIEC3 cells.
4. Establish whether time affects the induction of CYP1A1.

2. Method

2.1 Reagents

2.1.1 Cell Culture Chemicals

- Rat hepatoma H4-IIIEC3 cells cat # 85061112
- Minimum essential medium eagle (MEM) 100x cat # M2279
- Non essential amino acid solution 100x cat # M7145
- Fetal bovine serum cat # F7524
- L-Glutamine-penicillin-streptomycin 100x solution cat # G1146
- Dulbecco's phosphate buffered saline cat # D8537
- Trypsin-EDTA solution 10x cat # T4174

The H4-IIIECE cells and the medium reagents were purchased from Sigma (Dorset, UK).

2.1.2 Kits and Reagents

The 'Absolutely RNA[®] Miniprep Kit' (Catalogue #400800), 'AffinityScript[™] QPCR cDNA Synthesis Kit' (Catalogue #600559) and 'Brilliant[®] Multiplex QPCR Master Mix' (Catalogue #600553) were purchased from Stratagene (Amsterdam, The Netherlands).

'Quanti-iT[™] TM Ribogreen[®] RNA' assay kit (Catalogue #R11490), 'Quanti-iT[™] TM Picogreen[®] dsDNA' assay kit (Catalogue #P7589) and 'DNA ladder 1kb plus' (Catalogue #10488-085) were purchased from Invitrogen Molecular Probes (Paisely, UK).

2.1.3 Compounds and Solutions

2,3,7,8-Tetrachlorodibenzo-*p*-dioxin (TCDD) (purity 99%, catalogue # ED-901-B) was purchased from Cerilliant Cambridge Isotope Laboratories (Middlesex, UK). A 155M top stock of TCDD was made with dimethyl sulfoxide (DMSO) which was kept at room temperature and protected from light. Further dilution of TCDD was done in DMSO to 10 μ M which was aliquoted into eppendorf tubes and stored at -20°C. All further dilutions of TCDD were made using '24hr old' medium, giving a final DMSO concentration of <0.02%.

3-Methylcholanthrene (3-MC) (purity 98%, catalogue # 213942) was purchased from Aldrich. An initial top stock of 20 mM 3-MC was made by diluting in *p*-dioxane and stored at -20°C. The compound was also protected from light. Further dilutions were made using '24hr old' medium, giving a final DMSO concentration of ~0.01% and a final concentration of <0.001% *p*-dioxane. Visual inspection confirmed solubility (no analytic confirmation).

2,3,7,8-Tetrachlorodibenzofuran (TCDF) (Purity 98%, catalogue # EF-903-C) and **2,3,4,7,8-Pentachlorodibenzofuran (PeCDF)** (Purity 98%, catalogue # EF-956-C) were both purchased from Cerilliant Cambridge Isotope Laboratories (Middlesex, UK). A top stock of 100 mM was made for both compounds by diluting them into DMSO and stored at -20°C. Further dilutions of each compound were made using '24hr old' medium, giving a final DMSO concentration of <0.02%

3,3',4,4',5-Pentachlorobiphenyl (PCB 126) (Purity 98%, catalogue # PCB-126-C) was purchased from Cambridge Isotope Laboratories (Massachusetts, US). A top stock of 10 mM was made by dilution in DMSO. This was stored at -20°C with further dilutions made using '24hr old' medium, which gave a final DMSO concentration of <0.02%.

2-(4-Amino-3-Methylphenyl)Benzothiazol (DF 203) was produced by Cancer Research Laboratories at the University of Nottingham (UK) and the Drug Synthesis and Chemistry Branch (NCI) following published methods (Hutchinson *et al.*, 2001). The compound was kindly provided by Dr Tracey Bradshaw. A top stock of 10 mM was stored at -20°C and protected from light. Further dilutions of DF 203 were made using '24hr old' medium, giving a final DMSO concentration of <0.02%.

CH 223191 (2-Methyl-2*H*-Pyrazole-3-Carboxylic Acid (2-Methyl-4-*o*-Tolylazo-Phenyl)-Amide) (purity 95.71%) (Catalogue # 182705) was purchased from Calbiochem (Nottingham, UK). A 10 mM top stock was made by dilution into DMSO. The solution was stored at -20°C and protected from light. Further dilutions were done using '24hr old' medium, giving a final DMSO concentration of <0.02%.

2.1.4 Solutions, Buffers and Medium

Lysis buffer- β -ME: 0.7 μ l β -ME + 100 μ l Lysis Buffer (Absolutely RNA® Miniprep kit).

RNase-Free DNase I: 50 μ l of DNase Digestion Buffer + 5 μ l of reconstituted RNase-Free DNase I (Absolutely RNA® Miniprep kit).

De-proteinated water (DEPC treated water):

- 1 ml Diethyl Pyrocarbonate
- 9 ml Ethanol
- Distilled water to make up to 1 Litre (autoclaved after mixing to neutralise)

10X TBE buffer:

- 108 g Tris
- 55 g Boric Acid
- 40 ml 0.5M EDTA pH 8
- Distilled water to make mixture up to 1 Litre

10X Loading dye:

- 50% Glycerol
- 0.25% Bromophenol Blue
- 0.25% Xylene Cyanol FF
- 1 mM Ethylenediaminetetraacetic Acid (EDTA)

Complete Medium:

- 500 ml Essential Medium
- 50 ml Fetal Bovine Serum
- 5 ml L-Glutamine-Pencillin-Streptomycin Solution
- 5 ml Non-essential Amino Acids

1X TE buffer: pH 7.5

- 1 ml 20X TE Buffer
- 19 ml Purified Water

2.2 Measurement of CYP1A1 induction

2.2.1 Cell culture

2.2.1.1 Cell growth curve

H4-IIIECE rat liver cells (H4-IIIE) were used because of their fast life cycle and rapid exponential growth. A cell growth curve was constructed by counting cells with a haemocytometer, showing that total confluence of a 25cm² flask could be accomplished within 7 days when starting from a concentration of 10×10^5 cells/ml. H4-IIIEC3 cells were cultured in 96 well plates in 180 μ l medium which was changed after 96 hours. At the same time everyday cells were trypsinised with 60 μ l trypsin, washed in 60 μ l PBS and counted using a haemocytometer. This was done for 8 days generating a graph of cell growth.

2.2.1.2 Maintenance

When the flasks reached total confluence there was approximately 300×10^6 cells. All solutions are pre-heated to 37°C before being added to the cells. Passaging involved removing the old medium from the flask and washing the cells with 3 ml PBS. The PBS is removed and 1.5 ml trypsin added and incubated at 37°C for 1 minute. 3.5 ml of new medium is added and mixed with the trypsin-cell mixture to neutralise the trypsin. 9 ml of new medium is then added to a clean flask with 1 ml of the cell mixture. Cells are stored in an incubator at 37°C at 5% CO₂. All experiments were conducted between passage no. 8 and 22.

2.2.1.3 Treatment

Cells were cultured on a 96 well plate using a similar method to that used in section 2.2.1.2 but with the following exceptions. Initially, 200 μ l of cell mixture

is added to each well and allowed to settle for 2/3 days and until total confluence is reached or 90% confluence in the case of cells treated for 24 hours. Cells were washed with PBS then treated with particular mixture or compound. Each partial agonism assay will be split into two separate experiments: 1) location of the concentration of agonist which gives 15% of the maximal response, 2) treatment of cells with various concentrations of TCDD in the presence of the concentration found in the first experiment (with the exception of CH 233191, where the concentrations were derived from Kim *et al.*, 2006). Table 2.1 gives an example of concentration calculations for TCDD in the presence of 300 pM 3-MC. Initially, the concentration of TCDD will be ~10% higher before addition of medium containing the agonist is added to the solution; this gives more accurate final concentration for both compounds.

Ref.	Final TCDD Concentration	Medium	Volume of TCDD	Total after transfer	Volume of 3 nM 3-MC
A	100 nM	990µl	10µl of 10 µM	900µl	100µl
B	10 nM	900µl	100µl of 100 nM (A)	690µl	77µl
C	3 nM	490µl	210µl of 10 nM (B)	700µl	78µl
D	1 nM	900µl	100µl of 10 nM (B)	690µl	77µl
E	300 pM	490µl	210µl of 1 nM (D)	700µl	78µl
F	100 pM	900µl	100µl of 1 nM (D)	710µl	79µl
G	30 pM	490µl	210µl of 100 pM (F)	700µl	78µl
H	10 pM	720µl	80µl of 100 pM (F)	730µl	81µl
I	1 pM	630µl	70µl of 10 pM (H)	700µl	78µl
J	Untreated with 3MC	-	-	600µl	67µl
K	Untreated	-	-	600µl	0µl

Table 2.1: Dosing concentrations - Dilutions of concentrations used to dose H4-IIIECE cells with various concentrations of TCDD in the presence of 300 pM 3-MC. Table shows final concentration of TCDD, however a slightly higher concentration is used initially which is reduced when the medium containing agonist is added (e.g. 900µl 110 nM TCDD + 100µl 3 nM 3-MC = 1000µl 100 nM TCDD and 300 pM 3-MC). ‘Medium’ indicates 24 hour old medium (see section 2.2.1.3.)

The treatments were made freshly, with visual inspection of solubility (not analytical) and then added to cells. Agonist only treatments were designed using a similar method. Both assay types were dosed for 4 hours. For the time dependant induction assays, cells were treated with various concentrations of the agonist for either 4 or 24 hours. The concentrations are made up of 24 hour old medium, 0.1-0.2% DMSO and the particular treatment. 24hr old medium is medium which has been in the presence of a small quantity of cells for 24 hours and is used because of the presence of indirubin, an AhR agonist, found in fetal bovine serum (Adachi, 2001), which decreases after 24 hours. Doses contained only <0.02% DMSO which was found not to be toxic at such low concentrations. Controls included in the experiment may include; agonist/antagonist only control (AC) and 10 μ M TCDD only control (TC) with all experiments containing a vehicle control (VC). All concentrations were treated with triplicate replicates and kept as biological triplicates throughout RNA purification and cDNA synthesis.

Once the cells have been treated for the appropriate time, the medium is removed and 60 μ l PBS is used to wash the cells. This is removed and 60 μ l Trypsin is added and incubated for 1 min at 37°C. 120 μ l '24 hour old' medium is added to the trypsin-cell mixture and then all the mixture is transferred to an eppendorf tube. The tube is spun in a centrifuge for 5 minutes at 7000rpm at room temperature. The medium is then removed leaving a cell pellet attached to the bottom of the eppendorf tube ready for RNA purification.

2.2.2 RNA purification

RNA was purified using Stratagene Absolute Miniprep Kit as per instructions with the following alterations:

- ‘Appendix I: Protocol Modifications for small samples’ was followed omitting the prefiltration step.
- 100ul Lysis buffer with 0.7ul B-ME was added to each sample before 100ul of 70% ethanol.
- 30ul of Elution buffer was warmed to 60°C then added to the fiber matrix.
- Purified RNA samples were aliquoted and stored at -20°C.

Gel Electrophoresis was carried out as a qualitative measure of the RNA present in the samples. The gel consisted of 50 ml 1X TBE with 0.5g of agarose and 0.5 ml 10% SDS, which was melted and stored at 60°C till required. 1X TBE was used as the buffer. Each lane contained 6ul sample RNA, 1ul 10X loading dye and 3ul DEPC treated water. Unknown samples were compared against 1kb DNA ladder, positive RNA control and a negative control. The samples were run for 90 minutes at 90 volts and 400mA. Visualisation of the RNA was done using a post-staining technique of ethidium bromide staining for 25mins followed by a wash with DEPC treated water for 20mins. A Bio-rad UV camera (Bio-rad Labs, USA) was used to capture the DNA fragments using UV. Two bands are expected at 18s and 28s to indicate good quality RNA.

Quanti-iT™ Ribogreen® RNA assay kit was used to estimate the RNA concentrations in each sample and was also a useful way of checking the presence of the RNA instead of using a gel which required a large volume of RNA to

visualise it. A Wallac Victor² plate reader (Perkin Elmer) was used to measure the fluorescence from 0.5X Ribogreen dye. The plate reader was set at 485nm excitation and 510nm emission. Each unknown sample contained 0.5µl 200X Ribogreen dye, 2µl of RNA and 198µl 1X TE Buffer. A concentration curve was made using known concentrations of 0, 20, 100, 500 and 1000ng/ml RNA which allowed estimation of RNA in the unknown samples.

2.2.3 cDNA Synthesis

cDNA was produced using Stratascript QPCR cDNA Synthesis kit as per instructions but with the following alterations:

- 1µl of oligo primers and 1µl of random primers along with 1µl Reverse Transcriptase (RT) was added to 10µl Master Mix. Finally, 7µl of RNA was added giving a final total of 20µl.
- A no RT and a no RNA control were made to check for contamination of the reagents of cDNA or RNAs.
- A thermocycler (Techne 'Genius') was used, programmed for: 25°C for 5min, 42°C for 45mins, 95°C for 5min and then left at a storing temperature of 4°C.

The cDNA was stored at -20°C. The cDNA concentration was measured using Quanti-iT™ Picogreen® dsDNA assay kit as per instructions. A concentration curve was used to estimate the concentration of cDNA in each sample, using a linear curve with concentrations of 0, 10, 50, 100, 500 and 1000ng/ml. A Wallac Victor² plate reader (Perkin Elmer), which was set at 485nm excitation and 510nm emission, was used to measure the fluorescence produced by the Picogreen

dye. Each sample contained 0.5X Picogreen dye, 5 μ l unknown cDNA and 195 μ l TE Buffer. Picogreen dye required incubation for 2 minutes and was always protected from light. All the samples collected from the 96 well plates were found to have a cDNA concentration of 2-3ng/ml so purified water was added to each sample to give a final concentration of 2ng/ml for each sample.

2.2.4 Quantitative Real-Time PCR

2.2.4.1 Methodology

Quantification of activation of the AhR requires a robust method of quantifying induction of an AhR-dependent gene, in this case CYP1A1. Expression of the CYP1A1 gene was achieved using Quantitative Real-Time PCR (RT-PCR). The AhR and β -Actin genes were also quantified to use as a control. This involved developing a RT-PCR method which can be applied to several different AhR agonists.

2.2.4.2 Probes and Primers

The probe and primer sequences for RT-PCR were obtained from Bell *et al.* (2007). Table 2.2 shows the sequences of rat probes and primers used in RT-PCR for CYP1A1, AhR and β -Actin. Sequences are shown from 5' to 3', with Genbank Accession number, reporter dye and quencher dye. Bell *et al.*, (2007) found that these three genes could be run in the same reaction and verified the identity and reliability of the PCR products amplified by the primers (Bell *et al.*, 2007).

Gene	Sequence	GenBank Number	Labels
CYP1A1		X00469	
Primer (f)	CCACAGCACCATAAGAGATAACAAG		
Primer (r)	CCGGAAGTAGTTTGGATCAC		
Probe	ATAGTTCCTGGTCATGGTTAACCTGCCAC		FAM-BH1
AhR		K02422	
Primer (f)	GCAGCTTATTCTGGGCTACA		
Primer (r)	CATGCCACTTCTCCAGTCTTA		
Probe	TATCAGTTTATCCACGCCGCTGACATG		HEX-BH1
β-Actin		V01217	
Primer (f)	CTGACAGGATGCAGAAGGAG		
Primer (r)	GATAGAGCCACCATCCACA		
Probe	CAAGATCATTGCTCCTCCTGAGCG		ROX-BH2

Table 2.2: Sequences of Rat Probes and Primers - Forward (f) and Reverse (r) primers and probes are indicated. Table shows gene name and sequence with Genbank Accession number, reporter dye and quencher dye. Sequences are shown from 5' to 3'. FAM: iscarboxy fluorescein, HEX: hexachlorofluorescein and ROX: 5(6)-carboxy-X-rhodamine. The reporter dye is located at the 5' end of the probe, and the quencher dye, Black Hole-1 or -2 (BH1 or BH2), is found at the 3' end. Sequences and information obtained from Bell et al. (Bell *et al.*, 2007).

2.2.4.3 RT-PCR Efficiency

Development of an accurate RT-PCR method which can be applied to several different AhR agonists was the first prerequisite. It was found initially that PCR efficiencies for all three genes were ~60-90%, which is an anomalous result. One hypothesis for this is too much probe. Therefore the effects of a reduction in probe concentration from 200-600 nM to 100-300 nM, was tested using a TaqMan Thermocycler (Mx4000). A concentration curve (1 to 3.91×10^{-3} ng/ml) was created. A final volume of 12.5 μ l buffer solution was added to each well containing: 6.25 μ l master mix, A) 200-600 nM or B) 100-300 nM probes and

200-600 nM of the primer pairs with 2ng cDNA. Mx4000 software was used to calculate the PCR efficiency using a least mean squares curve fitting logarithm. Results concluded that a lower concentration of probe gave improvement of both correlation coefficient and slope, with efficiency of ~100-120% (See results 3.1.2.2). Critical analysis of PCR efficiency is thus a prerequisite for accurate data.

2.2.4.4 Measurement of CYP1A1 induction

Real-time PCR (RT-PCR) was done using a TaqMan Thermocycler (Mx4000). Each well contained 2 μ l of 2ng/ml cDNA from each unknown sample made to a final volume of 12.5 μ l with 10.5 μ l RT-PCR mixture (See table 2.3).

Component		Each Sample
Master mix		6.25 μ l
CYP1A1	Forward	0.25 μ l
	Reverse	0.25 μ l
	Probe	0.5 μ l
β-Actin	Forward	0.5 μ l
	Reverse	0.5 μ l
	Probe	1 μ l
AhR	Forward	0.75 μ l
	Reverse	0.5 μ l
	Probe	1.5 μ l

Table 2.3: Quantities of reagents used for each sample – Table shows the required volume of each probe and primer that makes up the correct proportions for the RT-PCR mixture. 2 μ l of 2ng sample cDNA will be added to this mixture. The initial concentration of all the primers and probes used was 10 μ M and 5 μ M, respectively (Diluted to required concentration using TE Buffer pH 7.5).

All reactions were done in duplicate (Duplicates of biological triplicates for each concentration tested). During each experiment, five separate controls were run simultaneously using the same RT-PCR mixture (Figure 2.3). Firstly, a 10 nM TCDD sample and an untreated sample, both from the same batch, were run allowing comparison between experiments. Secondly, internal controls were run for each individual experiment consisting of a no template control (NTC) to check for contamination in the RT-PCR master mix, a No RT and No RNA control to check contamination during the cDNA synthesis stage. A 40 cycle programme of 20 seconds at 95°C and 90 seconds at 58°C was used. The mRNA levels for each gene were calculated using PCR cycling threshold (C_t) values generated by the Mx4000 software. The C_t values for the control genes should be relatively similar so can be used to normalise the CYP1A1 RNA.

2.2.5 Qbase and Graph Software

Although the cDNA was normalized before RT-PCR it was still necessary to normalize the CYP1A1 RNA against both β -Actin and AhR RNA for increased accuracy. This was done using Qbase software (Hellemans *et al.*, 2007) which gives relative values of CYP1A1 RNA in comparison to levels of reference genes, β -Actin and AhR. To ensure accurate assessment of the results produced by Qbase, two quality measures are calculated. Firstly, the coefficient of variation (CV) of the normalized relative quantities, also known as the gene evaluation value, with a low value indicating high stability. Secondly, the geNorm value which measures the stability of the genes, confirming that they are stably expressed. This allows identification of the best genes to use for normalisation, which in these assays will always be a combination of both AhR and β -Actin.

With the exception of initial method calibration, data will be assessed based on the gene evaluation value alone.

The relative values for CYP1A1 RNA are then converted into percentages with the largest value denoted as 100%. In the instance of the partial agonism experiments, the curve, which was generated using Prism 5 software, had its lower limit set to the percentage of the maximal response of the antagonist in the absence of TCDD. This was generally about 15% of the induction of the maximal response of the agonists. Graphs were generated using a non linear regression curve with the settings 'log[agonist] vs. normalised response'. The Prism software also calculated the EC₅₀ and the 95% Confidence interval allowing comparison between partial agonism and control curves. Normalised CYP1A1 RNA data was plotted alongside the relevant controls which could include; agonist/antagonist only control (AC), 10 µM TCDD only control (TC) and vehicle control (VC).

3. Results

3.1 Cell Growth Curve

The growth of H4-IIE cells was characterised so accurate estimation of confluence could be conducted. Therefore, a cell growth curve was generated.

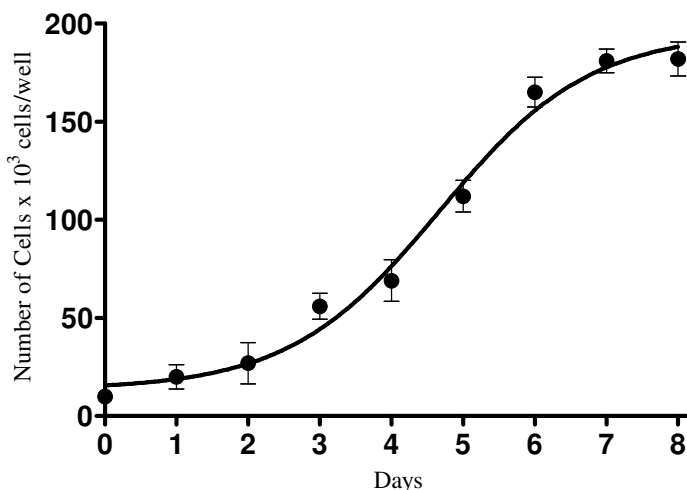

Figure 3.1: Cell Growth Curve for H4-IIEC3 – Cells were cultured in a 96 well plate with 180µl medium which was changed after 96 hours. On each day, cells were washed with PBS, trypsinised and counted with a haemocytometer as described in method 2.2.1.1. Each point equals mean \pm S.D. of 3 replicates.

Figure 3.1 shows the H4-IIEC3 cell growth curve over a period of 8 days. Confluence was reached after 6 days with concentrations of $\sim 2 \times 10^5$ cells/well.

3.2 CYP1A1 Induction - Method Calibration

3.2.1 Methodology

Quantification of activation of the AhR requires a robust method of quantifying induction of an AhR-dependent gene, in this case CYP1A1. This involves developing a RT-PCR method which can be applied to several different AhR

agonists. Initially, a dose-response curve was produced for TCDD which allowed construction and optimisation of a method of measurement of AhR activation.

3.2.3 Method calibration using TCDD

3.2.3.1 RNA and cDNA

H4-IIIEC3 Rat Liver cells were treated with TCDD (100 fM- 10 nM) for 4 hours. RNA was purified using Absolutely RNA Miniprep kit (Stratagene) as described (section 2.2.2). Quality of RNA was assayed using a 1X TBE agarose gel, post stained with ethidium bromide and photographed with Biorad UV camera (Figure 3.2).

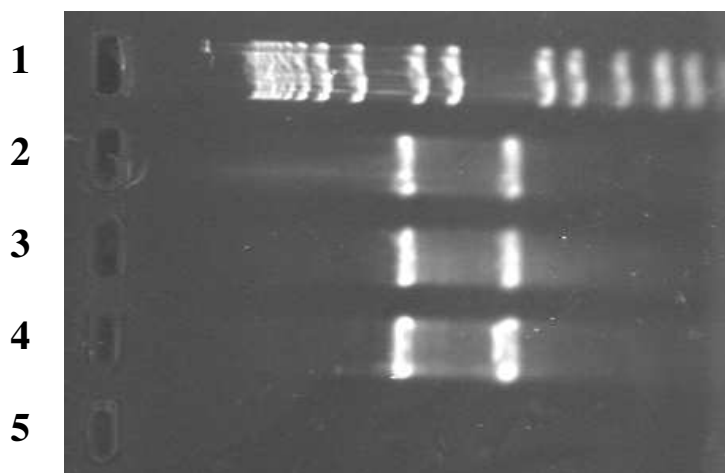

Figure 3.2: Agarose gel showing RNA - Cells were treated with and without TCDD for 4 hours; RNA was then purified as mentioned in the method (section 2.2.2). Samples were run for 90 mins (90 volts/max. 400mA). Gel was post stained with ethidium bromide. A digital image of the gel under UV illumination is shown. (Lane 1) 1kb DNA ladder, (Lane 2) positive control, (Lane 5) negative control, (Lane 3) untreated RNA and (Lane 4) 10 nM TCDD treated RNA.

Figure 3.2 shows bands at 18s and 28s confirming the quality of the purified RNA. RNA from the samples was then quantitated using a Ribogreen RNA quantitation Kit. A standard curve was produced with known RNA concentrations

allowing a comparative measure of RNA in the unknown samples (see method, section 2.2.2). RNA yield was typically 15-20 μg per well. RNA quality and quantity checks were only performed during method calibration and initial TCDD dose-response curve. cDNA was synthesised using AffinityScript QPCR cDNA Kit (see method, section 2.2.3). Quantitation of cDNA concentration was done using Picogreen cDNA quantitation Kit. A standard curve was used to measure cDNA quantities in each sample during every experiment. Yield was typically 1-3 μg cDNA per reaction.

3.2.2.2 Real Time-PCR

The induction of CYP1A1 RNA was chosen as it is one of the most sensitive measures of AhR activation. It is necessary to determine the efficiency of PCR, as this has a substantial effect on estimation of RNA amount. In order to test this, several standard curves were produced with various concentrations of probe. Each well contained the master mix (Table 2.2) with probe concentrations changed accordingly, and various concentrations of cDNA.

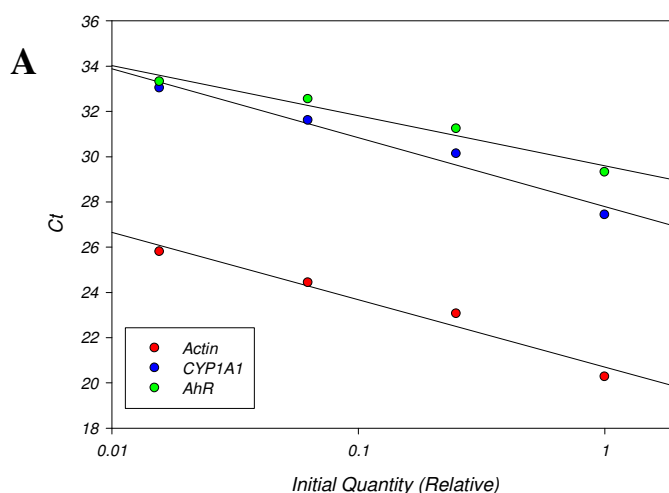

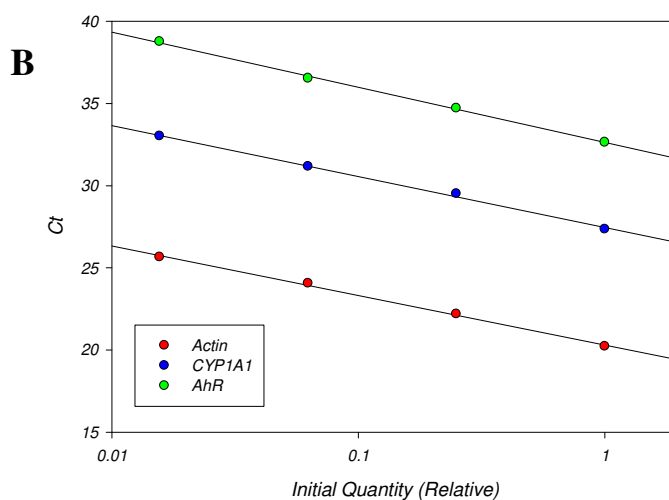
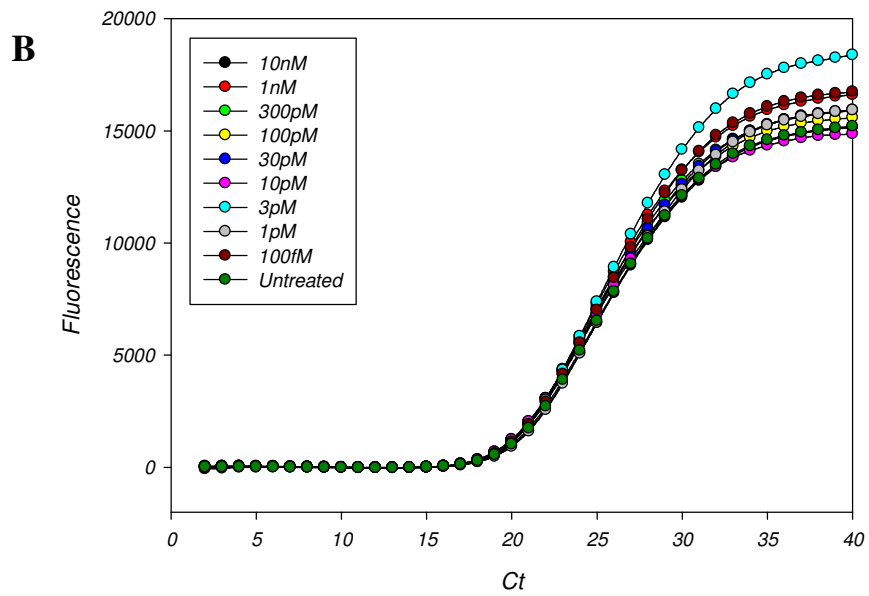
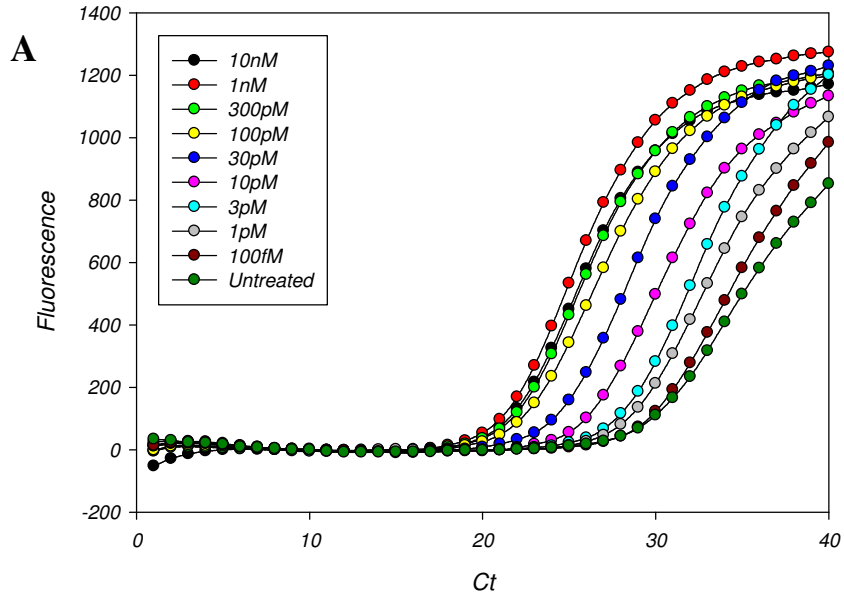

Figure 3.3: PCR efficiency for CYP1A1, β -Actin and AhR, (A) 200-600 nM Probe and (B) 100-300 nM Probe. A concentration gradient was constructed from a known cDNA concentration. RT-PCR was conducted as mentioned in method (section 2.2.4). The initial quantity of input cDNA is shown on the x-axis as a relative amount, and the C_t for each dilution is shown on the Y-axis, for n=3 replicates. The fit of the data to the line was determined by r^2 analysis, and the efficiency of PCR was determined from the slope of the line.

Figure 3.3A shows the amount of RNA measured (C_t) as a function of input cDNA; this analysis shows a poor fit of the data to the line of best fit (Figure 3.3A), and efficiency of PCR is ~60-105%, an anomalous result. The initial quantity of input cDNA is shown on the x-axis as a relative amount, and the C_t for each dilution is shown on the Y-axis, for n=3 replicates. The fit of the data to the line was determined by r^2 analysis, and the efficiency of PCR was determined from the slope of the line. The r^2 values for figure 3.3A were 0.982, 0.838 and 0.840 for CYP1A1, β -Actin and AhR, respectively. Figure 3.3B demonstrates the effect of a reduction in probe concentration from 200-600 nM to 100-300 nM, with improvement of both correlation coefficient and slope, with efficiency ~100-115%. The r^2 values for figure 3.3B were 0.997, 0.998 and 0.999 for CYP1A1, β -

Actin and AhR, respectively, providing a far bet fit than figure 3.3A. Analysis of PCR efficiency is thus a prerequisite for accurate data. Once PCR efficiency was improved, it was possible to measure the induction of CYP1A1 RNA by TCDD.



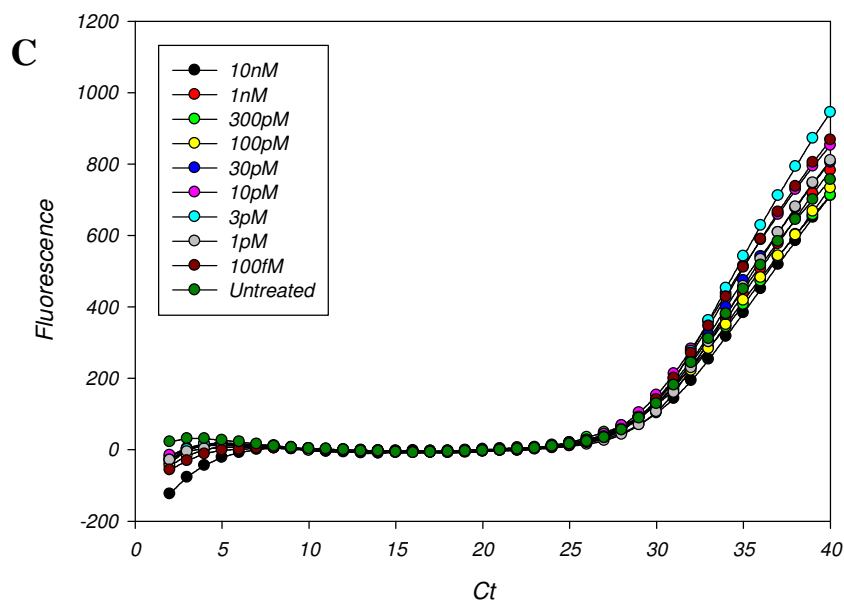

Figure 3.4: RT-PCR Amplification plots - (A) CYP1A1 (B) β -Actin and (C) AhR, when dosed with various concentrations of TCDD for 4hrs. RNA was purified, cDNA was synthesised and RT-PCR was run as demonstrated in the method (section 2.2.4). All genes were run in same well. The Y-axis shows the fluorescence at each C_t , for n=mean of 6 replicates (duplicates of 3 biological replicates).

Figure 3.4 shows the amplification plots for CYP1A1 and β -Actin when dosed with various concentrations of TCDD for 4 hours. The input cDNA was first normalized thus giving 2ng of cDNA per sample. Figure 3.4B and 3.4C shows that the control genes, β -Actin and AhR were unaffected by the TCDD treatment. Qbase was used to analyse the data derived from RT-PCR analysis. Qbase normalizes the expression of CYP1A1 against the reference genes, AhR and β -Actin. The reference gene expression should be within two-fold, indicating accurate sample preparation and quantitation. The amplification plots in figure 3.4 show the mean of 6 replicates with the average standard deviation = ± 0.8 .

3.2.2.3 Dose-response curve

RT-PCR was used to measure CYP1A1 induction with the results normalised to relative quantities using Qbase. Qbase calculates two quality measures, firstly, the coefficient of variation (CV). The CV, also known as the gene evaluation value, for AhR and β -Actin was 16% and 19%, respectively, indicating high stability. Secondly, the geNorm value, which measures the stability of the genes (Hellenmans *et al.*, 2006): 0.37, confirming that they are stably expressed; further work will only look at the gene evaluation value (see method, section 2.2.5).

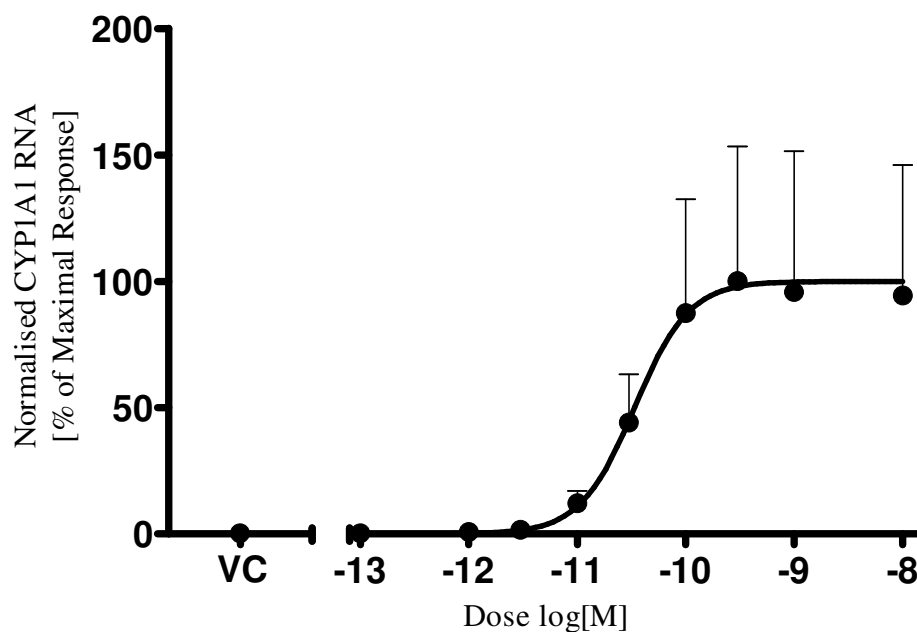

Figure 3.5: Induction of CYP1A1 RNA by TCDD. H4-IIIEC3 cells were treated with the indicated dose of TCDD, or vehicle control, for four hours, as described in materials and methods section 2.2.1. RNA was isolated from cells, and analysed for CYP1A1, β -Actin and AhR RNAs by real-time PCR, as described in section 2.2. CYP1A1 RNA was normalised using Qbase (section 2.2.5) against β -Actin and AhR RNAs, and then normalised to the maximum response, which is shown as 100%. The response of CYP1A1 against log dose is shown, and each point represents $n=3$ biological replicates, \pm S.D. VC: Vehicle control.

The last phase was to produce a dose-response curve using the normalized relative quantities (NRQ) of CYP1A1 RNA calculated by Qbase. The EC_{50} and the 95% confidence intervals for the EC_{50} were determined using a non linear regression curve with the settings 'log[agonist] vs. normalised response'. Figure 3.5 shows the response of CYP1A1 against the dose. The plot of response of CYP1A1 against log dose yields an $EC_{50} = 34$ pM, 95% Confidence interval = 29 pM - 38 pM. The dose/response relationship shows a classical curve with a small 95% CI due to the use of multiple concentrations. Replicate EC_{50} estimates were similar in four repeats (Figure 3.7). CYP1A1 (Figure 3.4A) was induced by ~150-fold over control (10 nM against vehicle) with high induction indicating large signal to noise ratio and accurate induction parameters.

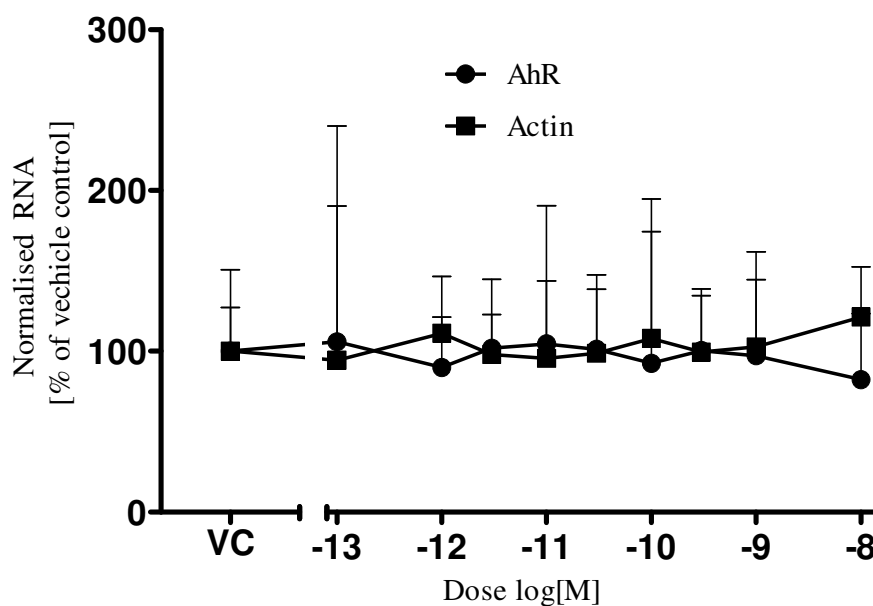

Figure 3.6: Confirmation of no induction by AhR or β -Actin RNA by TCDD. H4-IIIEC3 cells were treated with the indicated dose of TCDD, or vehicle control, for 4 hours, as described in section 2.2.1. RNA was isolated from cells, and analysed for CYP1A1, β -Actin and AhR RNAs by real-time PCR, as described in section 2.2. The two reference genes have been compared against maximal normalised value of CYP1A1 RNA. The response of β -Actin and AhR against log dose is shown, and each point represents n=3 biological replicates, \pm S.D. VC: Vehicle control.

Figure 3.6 demonstrates that the reference genes, β -Actin and AhR, were unaffected by the treatment even at the maximum concentrations of TCDD.

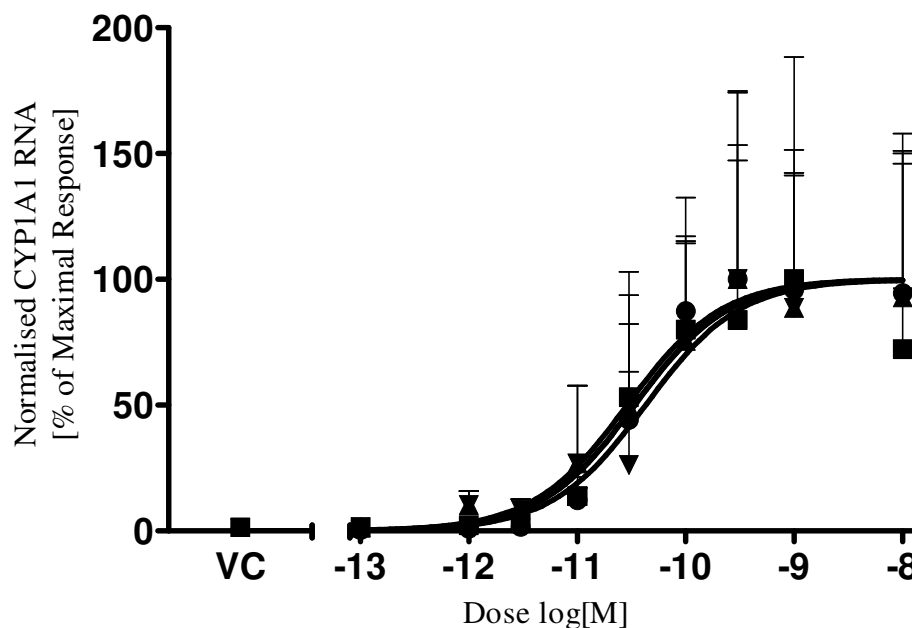

Figure 3.7: Induction of CYP1A1 RNA by TCDD – Comparisons of Four Separate TCDD D/R Curves - H4-IIIEC3 cells were treated with the indicated concentrations of TCDD for 4 hours. The graph shows four curves taken from each experiment in section 3.2. Cell treatment, RNA isolation and RT-PCR analysis was as described for Figure 3.5. The normalised response of CYP1A1 against log dose is shown, and each point represents n=3 biological replicates, \pm S.D. VC: Vehicle control.

Figure 3.7 compares four TCDD only dose-response curves taken from various assays in section 3.2. The curves have a similar shape with considerable overlapping of means and 95% confidence intervals. This gave an average EC_{50} of 35 pM (S.D. = \pm 5.8 pM). The average of the Qbase derived gene evaluation values were ~25% and ~33% for β -Actin and AhR, respectively. This allows comparison of data between assays as the EC_{50} of each TCDD curve is similar and provides evidence that each repeat is reproducible and hence reliable.

3.3 Partial Agonism Assays

3.3.1 Methodology

The ability of known AhR agonists to act as partial agonists of the induction of CYP1A1 was evaluated by determining if these chemicals could antagonise the induction of CYP1A1 RNA by TCDD in H4-IIIEC3 cells, as previously reported. Five different AhR agonists and one AhR antagonist were evaluated. The approach taken was to determine the amount of test chemical that would give approximately 15% of maximal induction of CYP1A1 RNA; this concentration of chemical was then used to determine whether it could antagonise the induction of CYP1A1 RNA by TCDD.

3.3.2 3-Methylcholanthrene (3-MC)

The induction of CYP1A1 RNA by 3-Methylcholanthrene (3-MC) was examined. Cells were treated with 3-MC (1 μ M to 1 pM) and compared with a vehicle control (VC). The reference genes had gene evaluation values of 46% and 39% for β -Actin and AhR, respectively. The data was plotted into a dose-response curve (figure 3.8) which has an $EC_{50} = 2.3$ nM (95% Confidence interval = 1.3 nM to 3.8 nM). The concentration at which 15% of maximal response was reached was 300 pM. Thus this experiment robustly estimates the agonist potency of 3-MC.

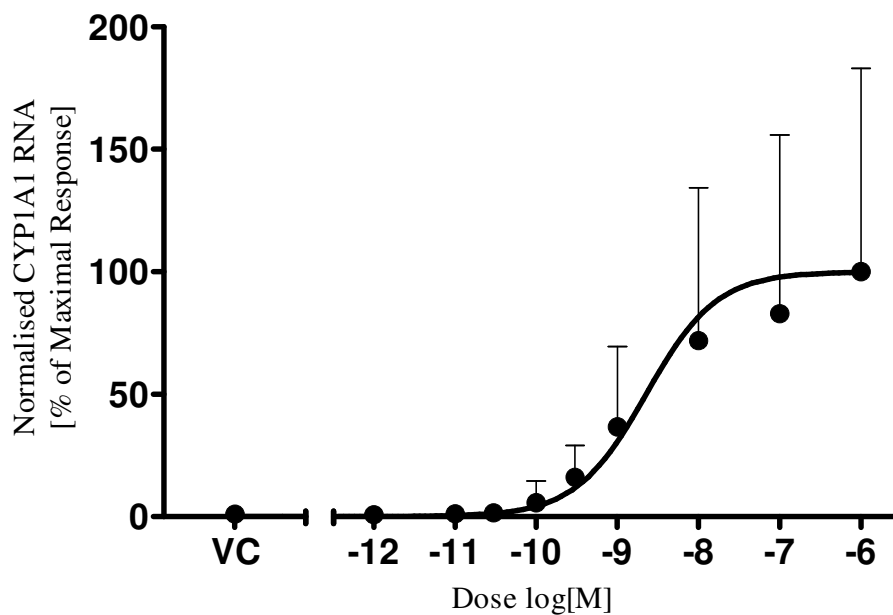

Figure 3.8: Induction of CYP1A1 RNA by 3-MC - H4-IIIEC3 cells were treated with the indicated dose of 3-MC, or vehicle control, for four hours, as described in materials and methods section 2.2.1. RNA was isolated from cells, and analysed for CYP1A1, β -Actin and AhR RNAs by real-time PCR, as described in section 2.2. CYP1A1 RNA was normalised using Qbase (section 2.2.5) against β -Actin and AhR RNAs, and then normalised to the maximum response, which is shown as 100%. The response of CYP1A1 against log dose is shown, and each point represents $n=3$ biological replicates, \pm S.D. VC: Vehicle control.

In order to determine whether 3-MC could act as an antagonist, cells were treated with various concentrations of TCDD (100 nM to 1 pM) in the presence or absence of 300 pM 3-MC. This was compared to an agonist only control (AC) and vehicle control (VC).

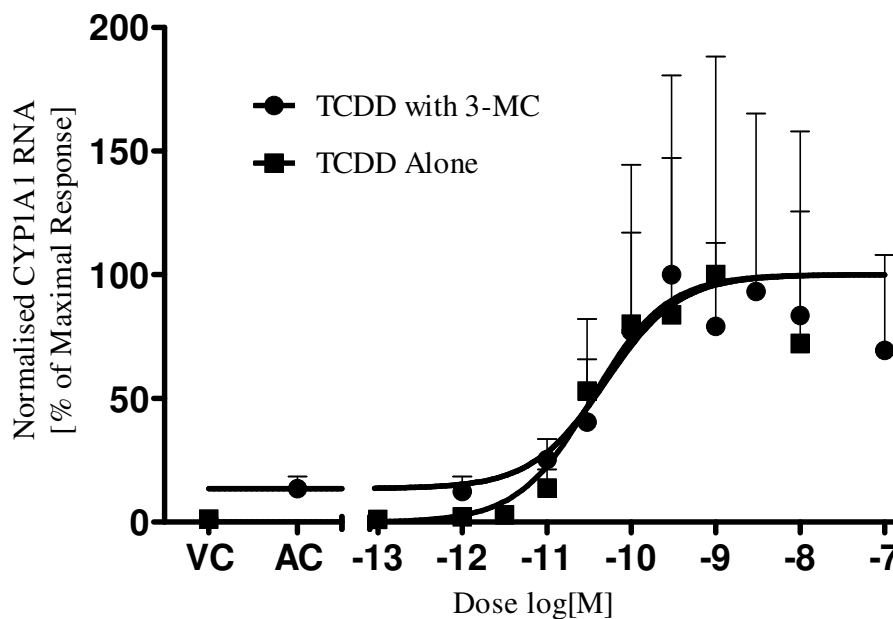

Figure 3.9: Induction of CYP1A1 RNA by TCDD with and without 300 pM 3-MC - H4-IIIEC3 cells were treated with the indicated concentrations of TCDD, in the presence or absence of 300 pM 3-MC. Cell treatment, RNA isolation and RT-PCR analysis was as described for Figure 3.8. The normalised response of CYP1A1 against log dose is shown, and each point represents $n=3$ biological replicates, \pm S.D. VC: Vehicle control. AC: Agonist only control.

Figure 3.9 shows TCDD in the presence and absence of 300 pM 3-MC. The results show that the response to 3-MC only control (AC) is approximately 15% of maximal induction. The gene evaluation values were 17% and 19% for AhR and β -Actin, respectively: this shows that there is little variation in the measurements of AhR and β -Actin, thereby giving confidence in the RT-PCR. The EC_{50} of TCDD with 3-MC was 49 pM (95% confidence interval = 19 pm-126 pM) compared with an EC_{50} of 50 pM (95% Confidence interval = 19 pM to 133 pM) for TCDD alone: these are not significantly different, thus 3-MC has no detectable antagonist activity in this assay.

3.3.3 2,3,7,8-Tetrachlorodibenzofuran (TCDF)

The induction of CYP1A1 RNA by 2,3,7,8-Tetrachlorodibenzofuran (TCDF) was analysed. H4-IIIEC3 cells were treated with various concentrations of TCDF or vehicle control (VC) to characterise the induction of CYP1A1 RNA. AhR and β -Actin gave gene evaluation values of 102% and 65%, respectively. An EC_{50} of 5.8 nM (95% confidence interval of 2.8 nM to 11 nM) was estimated for induction of CYP1A1 RNA (figure 3.10). This gave a concentration of 300 pM TCDF (15% of maximal response) which was then added to TCDD treated cells (various concentrations between 10 nM and 100 fM).

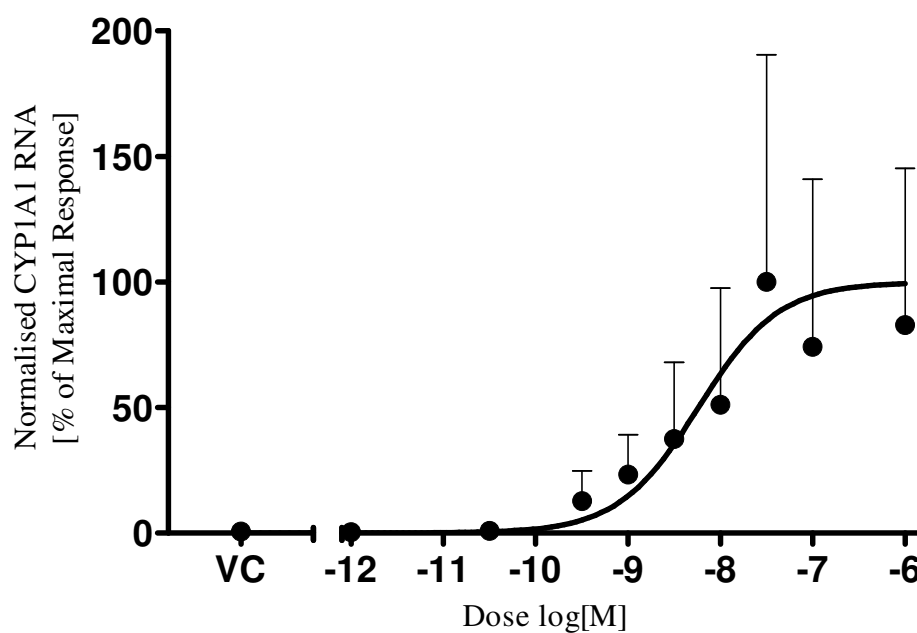

Figure 3.10: Induction of CYP1A1 RNA by TCDF - H4-IIIEC3 cells were treated with the indicated concentrations of TCDF. Cell treatment, RNA isolation and RT-PCR analysis was as described for Figure 3.8. The normalised response of CYP1A1 against log dose is shown, and each point represents n=3 biological replicates, \pm S.D. VC: Vehicle control.

The dose-response curve for TCDD in the presence of 300 pM TCDF is shown in figure 3.11 which has been compared with a TCDD only curve. A 300 pM TCDF

only control (AC) and a vehicle control (VC) were also run in the same experiment. Gene evaluation values were 51% and 38% for AhR and β -Actin, respectively. Cells exposed to TCDF alone induced CYP1A1 RNA to 39.5% of maximal induction however it is still possible to use the data to compare the EC_{50} for each curve.

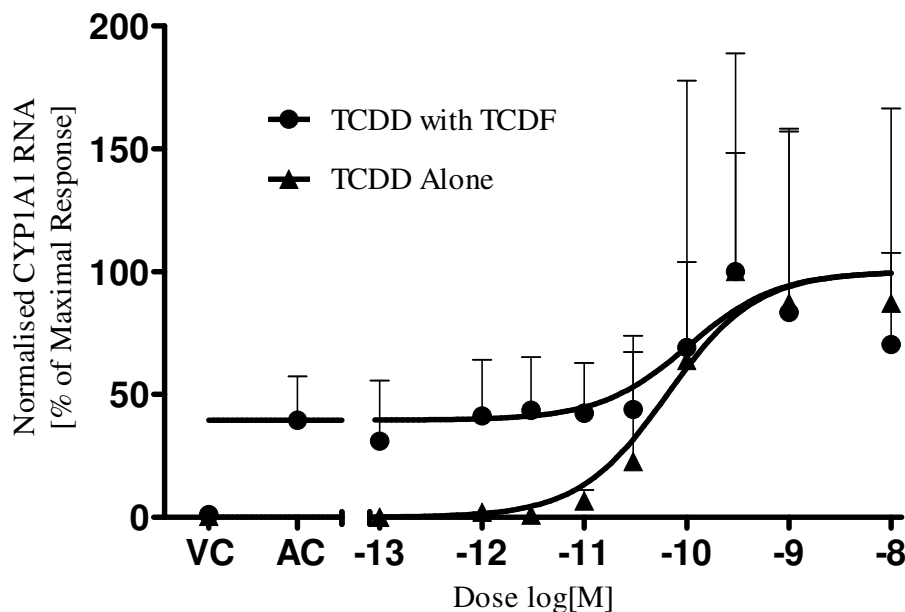

Figure 3.11: Induction of CYP1A1 RNA by TCDD with and without TCDF - H4-IIIEC3 cells were treated with the indicated concentrations of TCDD, in the presence or absence of 300 pM TCDF. Cell treatment, RNA isolation and RT-PCR analysis was as described for Figure 3.8. The normalised response of CYP1A1 against log dose is shown, and each point represents n=3 biological replicates, \pm S.D. VC: Vehicle control. AC: Agonist only control.

The results for TCDD with 300 pM TCDF show that the background is approximately 40% induction of the possible antagonist, TCDF, however when the EC_{50} of TCDD with TCDF ($EC_{50} = 104$ pM, 95% CI = 20 pM-535 pM) is compared with TCDD alone ($EC_{50} = 65$ pM, 95% CI = 39 pM-107 pM) there is no significant difference with complete crossover of the 95% confidence intervals.

Therefore it can be concluded that TCDF exhibited no detectable antagonistic properties in this experiment.

3.3.4 2,3,4,7,8-Pentachlorodibenzofuran (PeCDF)

2,3,4,7,8-Pentachlorodibenzofuran (PeCDF) was added to cells for 4 hours and the induction of CYP1A1 RNA was measured to locate the concentration of PeCDF which gives 15% of the maximal response. Gene evaluation values were 48% and 40% for AhR and β -Actin, respectively.

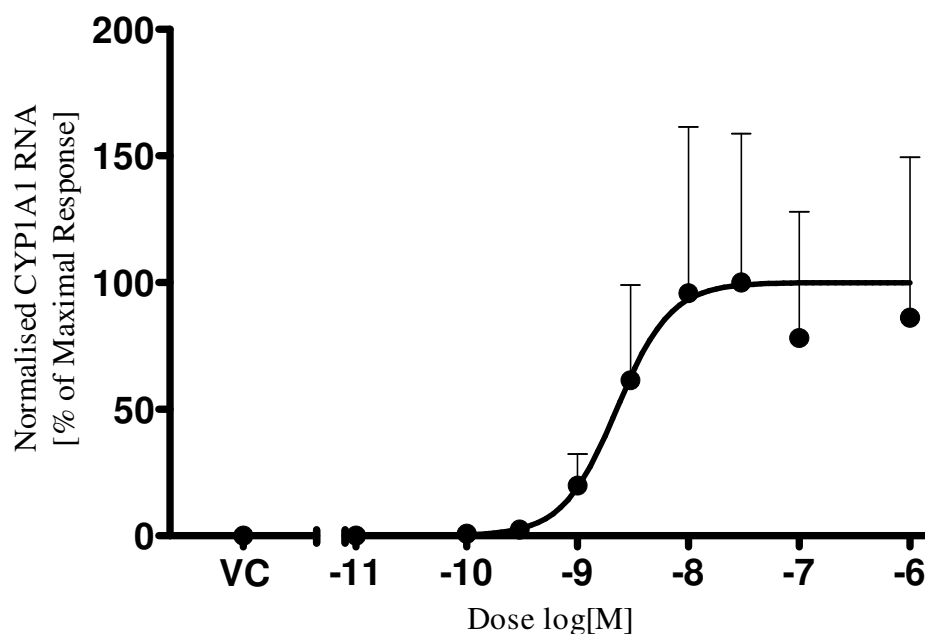

Figure 3.12: Induction of CYP1A1 RNA by PeCDF - H4-IIIEC3 cells were treated with the indicated concentrations of PeCDF. Cell treatment, RNA isolation and RT-PCR analysis was as described for Figure 3.8. The normalised response of CYP1A1 against log dose is shown, and each point represents n=3 biological replicates, \pm S.D. VC: Vehicle control.

Figure 3.12 shows the dose-response curve for PeCDF with the EC_{50} as 2.2 nM (95% CI = 1.4 nM to 3.4 nM) and reveals the concentration for 15% of maximal

response which was 1 nM. H4-IIIEC3 cells were then treated with various concentrations of TCDD (10 nM – 100 pM) with the addition of 1 nM PeCDF. A 1 nM PeCDF only control (AC) and a vehicle control (VC) were also included. The TCDD with PeCDF dose-response curve was compared with a TCDD alone curve (Figure 3.13) and shows that the background is 14% induction of the possible antagonist, PeCDF.

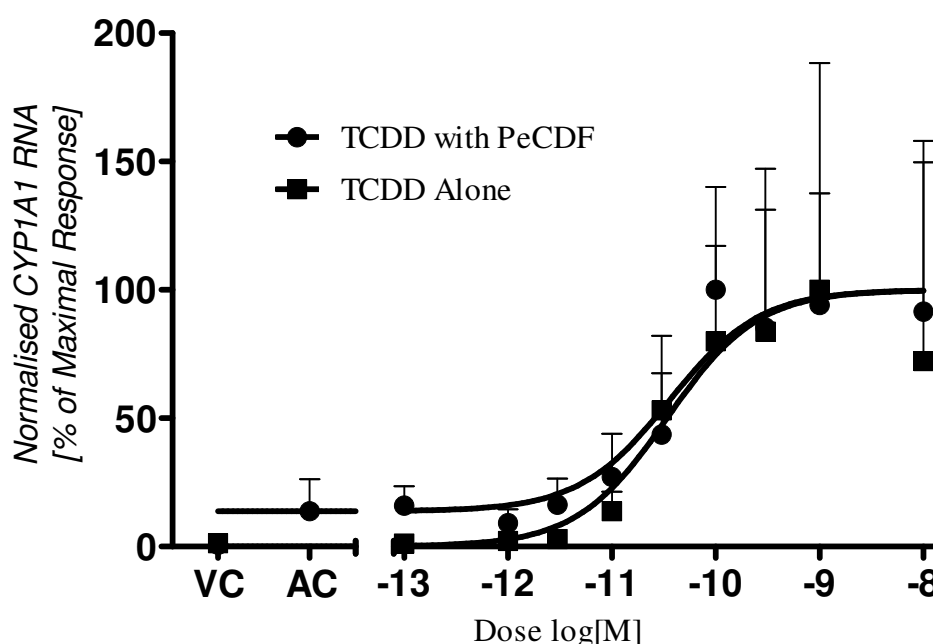

Figure 3.13: Induction of CYP1A1 RNA by TCDD with and without 1 nM PeCDF - H4-IIIEC3 cells were treated with the indicated concentrations of TCDD, in the presence or absence of 1 nM PeCDF. Cell treatment, RNA isolation and RT-PCR analysis was as described for Figure 3.8. The normalised response of CYP1A1 against log dose is shown, and each point represents n=3 biological replicates, \pm S.D. VC: Vehicle control. AC: Agonist only control.

Normalised quantities of AhR and β -Actin reference genes had gene evaluation values of 21% and 20%, respectively. The EC_{50} of TCDD with PeCDF was 24 pM (95% CI = 13 pM-46 pM) which was compared against TCDD alone (EC_{50} = 34 pM, 95% CI = 18 pM-63 pM) and was found to be significantly similar, with

considerable crossover of the 95% confidence intervals of the EC_{50} s. The results have demonstrated that PeCDF has no antagonist properties in this experiment.

3.3.5 3,3',4,4',5- Pentachlorobiphenyl (PCB 126)

The induction of CYP1A1 RNA by 3,3',4,4',5- Pentachlorobiphenyl (PCB 126) was measured. Cells were treated for 4 hours with various concentrations of PCB 126 (100 nM to 1 pM) and compared with a vehicle control (VC).

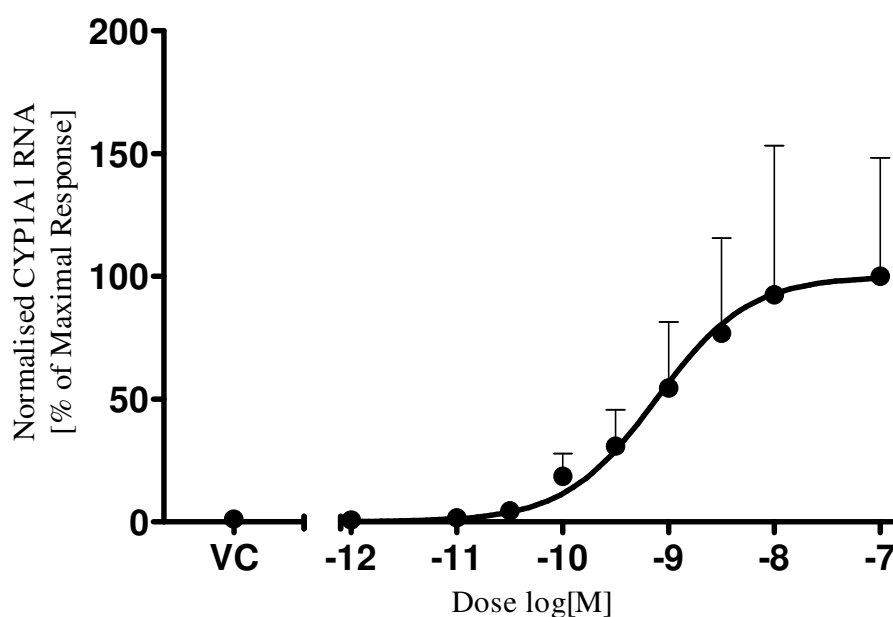

Figure 3.14: Induction of CYP1A1 RNA by PCB 126 - H4-IIIEC3 cells were treated with the indicated concentrations of PCB 126. Cell treatment, RNA isolation and RT-PCR analysis was as described for Figure 3.8. The normalised response of CYP1A1 against log dose is shown, and each point represents $n=3$ biological replicates, \pm S.D. VC: Vehicle control.

Figure 3.14 shows dose compared with the normalised induction of CYP1A1 by PCB 126 which was derived from the normalisation of CYP1A1 RNA by Qbase (gene evaluation values of 14% and 12% for β -Actin and AhR, respectively). The curve shows the EC_{50} which was 765 pM (95% CI = 645 pM-907 pM) and allows identification of the concentration of PCB 126 which gives 15% of maximal

induction which was 100 pM. Cells were then treated with various concentrations of TCDD (10 nM to 100 fM) in the presence of 100 pM PCB 126 for 4 hours and compared with a 100 pM PCB 126 only control (AC) and a vehicle control (VC). CYP1A1 RNA was then normalised using Qbase software against the reference genes, β -Actin and AhR (gene evaluation values of 48% and 68%, respectively).

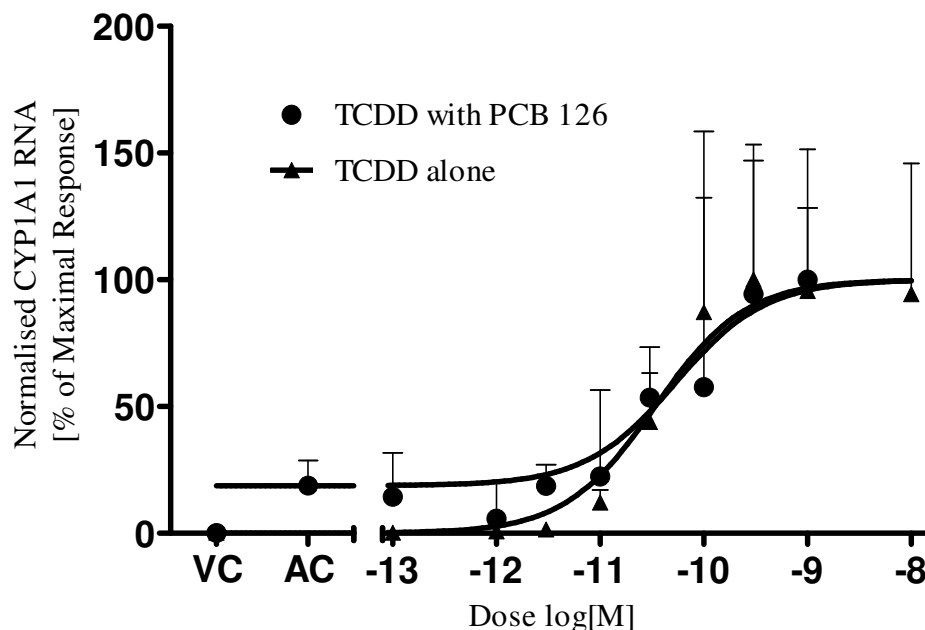

Figure 3.15: Induction of CYP1A1 RNA by TCDD with and without PCB 126 - H4-IIIEC3 cells were treated with the indicated concentrations of TCDD in the presence and absence of 100 pM PCB 126. Cell treatment, RNA isolation and RT-PCR analysis was as described for Figure 3.8. The normalised response of CYP1A1 against log dose is shown, and each point represents n=3 biological replicates, \pm S.D. VC: Vehicle control. AC: Agonist only control.

Figure 3.15 shows the induction of CYP1A1 by TCDD in the presence and absence of 100 pM PCB 126 compared with a 100 pM PCB 126 only control (AC) and a vehicle control (VC). The EC_{50} of TCDD with PCB 126 was 66 pM (95% CI = 31 pM-139 pM) which was compared with TCDD alone (EC_{50} = 34 pM, 95% CI = 22 pM-51 pM). This comparison shows that there is no significant

difference between the EC₅₀s and demonstrates that in this assay PCB 126 has no antagonistic effects in the presence of TCDD.

3.3.6 2-(4-Amino-3-Methylphenyl)-Benzothiazole (DF 203)

Previous literature (Bazzi, 2008; Chau *et al.*, 2000; Elferink *et al.*, 2003; Loaiza-Perez *et al.*, 2002) has described 2-(4-Amino-3-Methylphenyl)Benzothiazole (DF 203) as having agonist properties but with data collected by Bazzi (2008), the potential antagonistic effects should also be investigated. The induction of CYP1A1 RNA by DF 203 shown in figure 3.16 demonstrates that the compound has agonist properties. Cells were treated with various concentrations of DF 203 (100 μ M to 1 nM) which was compared with a vehicle control (VC).

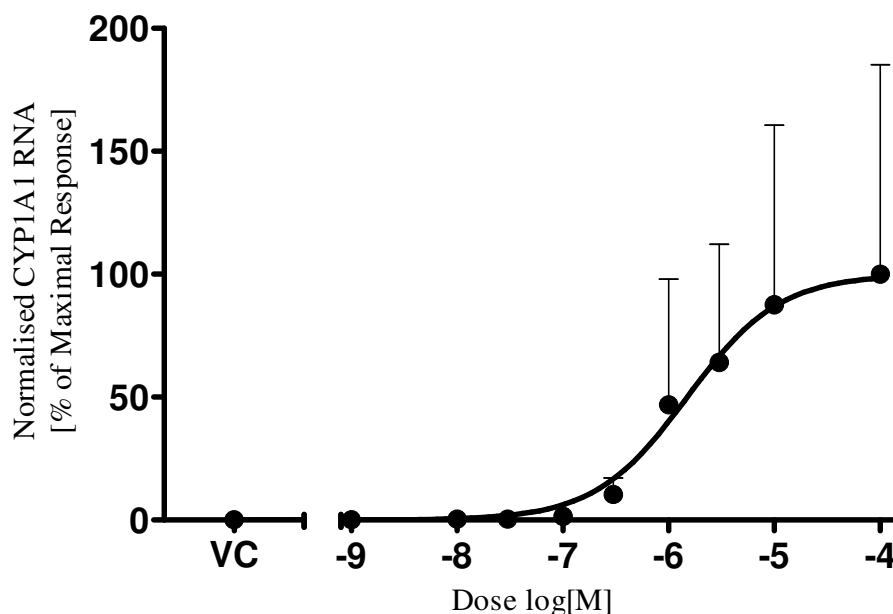

Figure 3.16: Induction of CYP1A1 RNA by DF 203 - H4-IIIEC3 cells were treated with the indicated concentrations of DF 203. Cell treatment, RNA isolation and RT-PCR analysis was as described for Figure 3.8. The normalised response of CYP1A1 against log dose is shown, and each point represents n=3 biological replicates, \pm S.D. VC: Vehicle control.

Figure 3.16 shows the induction of CYP1A1 RNA by DF 203 which has an EC_{50} of 1.5 μ M (95% CI = 1.2 μ M-1.8 μ M). Gene evaluation values of 13% and 13% for β -Actin and AhR, respectively. The curve also allows location of the concentration that gives 15% of maximal induction which was estimated, based on the curve, to be 300 nM. Cells were then treated with various concentrations of TCDD in the presence of 300 nM DF 203 which was compared with a 300 nM DF 203 only control (AC) and a vehicle control (VC). β -Actin and AhR gene evaluation values were 19% and 21%, respectively.

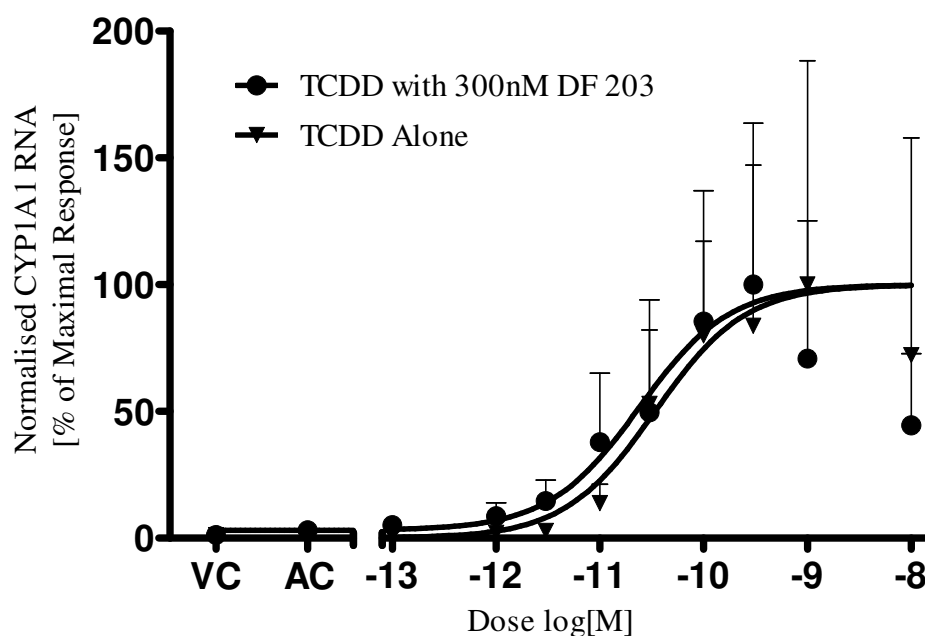

Figure 3.17: Induction of CYP1A1 RNA by TCDD with and without 300 nM DF 203 - H4-IIIEC3 cells were treated with the indicated concentrations of TCDD in the presence and absence of 300 nM DF 203. Cell treatment, RNA isolation and RT-PCR analysis was as described for Figure 3.8. The normalised response of CYP1A1 against log dose is shown, and each point represents $n=3$ biological replicates, \pm S.D. VC: Vehicle control. AC: Agonist only control.

Figure 3.17 shows the induction of CYP1A1 RNA by TCDD in the presence of 300 nM DF 203 (EC_{50} = 24 pM, 95% CI = 7.2 pM-79 pM). This was compared with TCDD alone (EC_{50} = 34 pM, 95% CI = 18 pM-63 pM). It can be seen from

the results that 15% of maximal induction by 300 nM DF 203 was not reached by the agonist only control or the lower concentrations of TCDD with DF 203 and there is no significant difference between EC_{50} s. Due to this a second dose-response curve for TCDD in the presence of DF 203 was produced but using a larger concentration of DF 203. In the second dose-response curve, a concentration of 1 μ M DF 203 was added to cells treated with various concentrations of TCDD (10 nM to 100 fM).

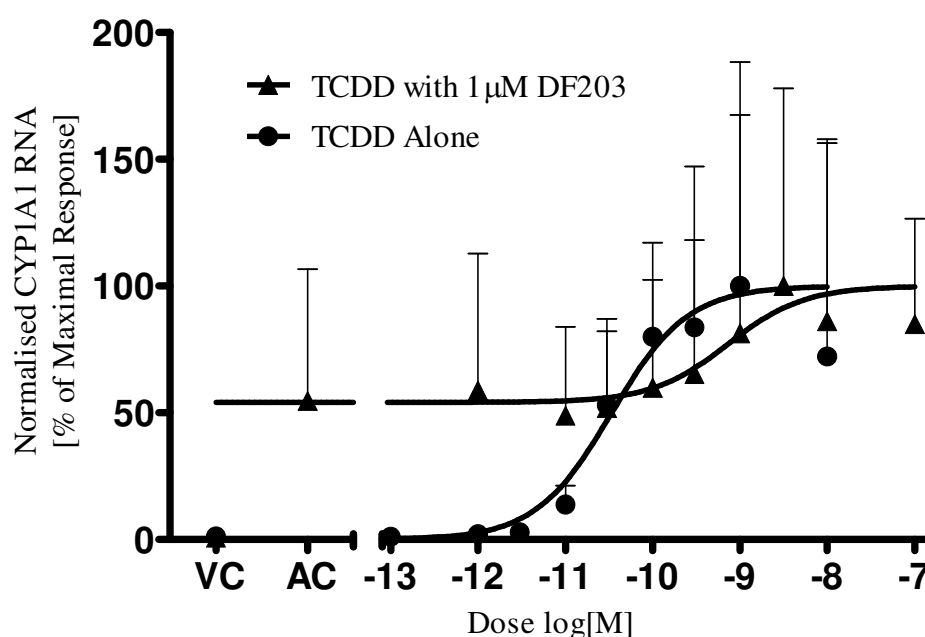

Figure 3.18: Induction of CYP1A1 RNA by TCDD with and without 1 μ M DF 203 - H4-IIIEC3 cells were treated with the indicated concentrations of TCDD in the presence and absence of 1 μ M DF 203. Cell treatment, RNA isolation and RT-PCR analysis was as described for Figure 3.8. The normalised response of CYP1A1 against log dose is shown, and each point represents $n=3$ biological replicates, \pm S.D. VC: Vehicle control. AC: Agonist only control.

Reference genes, β -Actin and AhR, had gene evaluation values of 11% and 10%, respectively. Figure 3.18 shows that there is a background of 54% induction in the presence of 1 μ M DF 203. The EC_{50} of TCDD with DF 203, which was 726 pM (95% CI = 69 pM-7.6 nM), was significantly different from that of TCDD alone

($EC_{50} = 34 \text{ pM}$, 95% CI = 18 pM-63 pM) and there is no crossover of 95% confidence intervals. It can be seen that in the presence of DF 203, the TCDD induction curve moves to the right demonstrating that DF203 has both agonistic and antagonistic properties.

3.3.7 CH 223191

A known antagonist, 2-methyl-2*H*-pyrazole-3-carboxylic acid (2-methyl-4-*o*-tolylazo-phenyl)-amide (CH 223191) has no reported agonist properties. Kim *et al.* (2006), and this paper looked to estimate concentrations of CH 223191 that would provide antagonism in the presence of TCDD. Using data from the study by Kim *et al.* (2006), two concentrations of antagonist were determined, 300 nM and 10 μM . As in previous assays, cells were treated with various concentrations of TCDD (10 nM to 100 fM) however; in this instance they were also compared with a 10 μM TCDD only control to confirm maximal response. An antagonist only control (10 μM CH 223191) was also performed to confirm that the compound had no agonist properties. In figure 3.19, 300 nM CH 223191 was added to various concentrations of TCDD and compared with a 10 μM TCDD (TC), an antagonist only control (AC) and a vehicle control (VC). Gene evaluation values of 58% and 41%, for AhR and β -Actin.

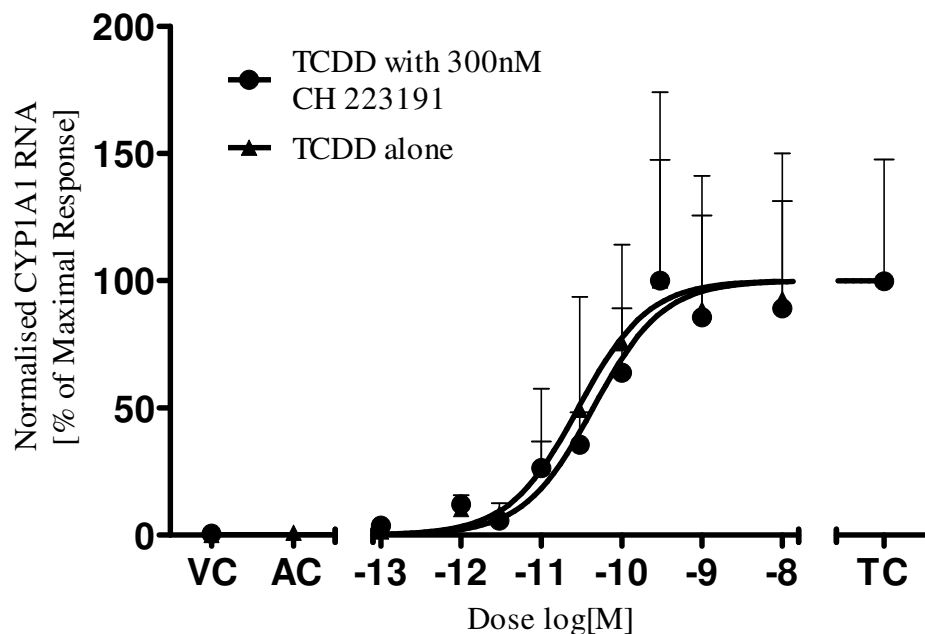

Figure 3.19: Induction of CYP1A1 RNA by TCDD with and without 300 nM CH-223191 - H4-IIEC3 cells were treated with the indicated concentrations of TCDD in the presence and absence of 300 nM DF 203. Cell treatment, RNA isolation and RT-PCR analysis was as described for Figure 3.8. VC: Vehicle control, AC: Antagonist only control, TC: 10 μ M TCDD only control. The normalised response of CYP1A1 against log dose is shown, and each point represents $n=3$ biological replicates, \pm S.D.

Figure 3.19 shows various concentrations of TCDD in the presence and absence of 300 nM CH 223191. The EC_{50} of TCDD with CH 223191 was 44 pM (95% CI = 28 pM - 70 pM) which was compared with TCDD alone (EC_{50} = 29 pM, 95% CI = 21 pM - 39 pM). The data shows that there is no difference between EC_{50} s with the 95% CI from each curve overlapping considerably. It is therefore possible to deduce that at this concentration of antagonist, CH 223191 has no effect on the induction of CYP1A1 by TCDD. One possibility is that a larger concentration of CH 223191 is required to obtain measurable antagonism. In the next assay, 10 μ M of CH 223191 was added to TCDD treated cells (various concentrations). This was also compared with a 10 μ M TCDD only control (TC),

antagonist only control (AC) and a vehicle control (VC). Gene evaluation values of 88% and 53% were obtained for AhR and β -Actin, respectively.

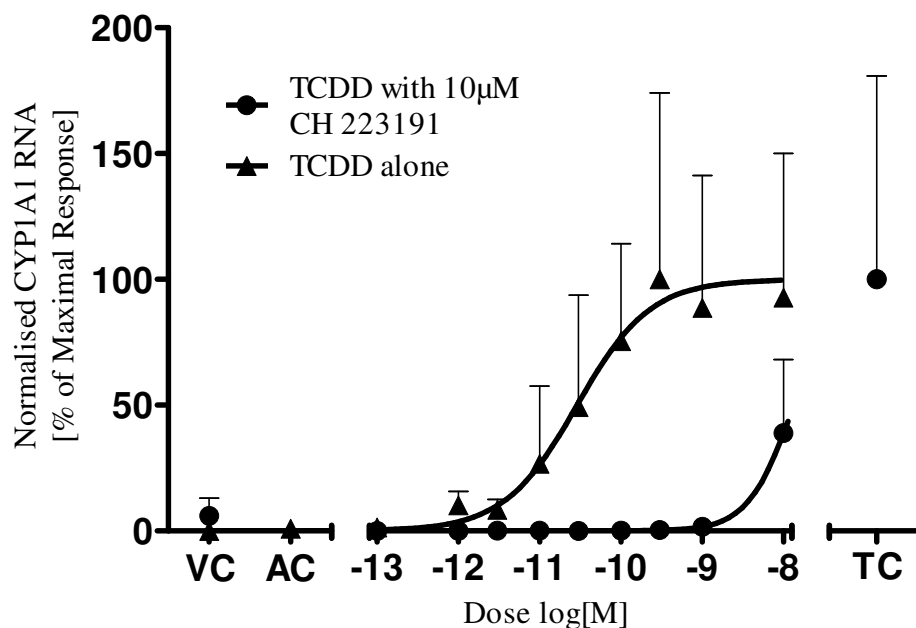

Figure 3.20: Induction of CYP1A1 RNA by TCDD with and without 10 μ M CH-223191 - H4-IIIEC3 cells were treated with the indicated concentrations of TCDD in the presence and absence of 10 μ M CH 223191. Cell treatment, RNA isolation and RT-PCR analysis was as described for Figure 3.8. VC: Vehicle control, AC: Antagonist only control, TC: 10 μ M TCDD only control. The normalised response of CYP1A1 against log dose is shown, and each point represents $n=3$ biological replicates, \pm S.D.

It can be seen in figure 3.20 that CH 223191 has inhibited the induction of CYP1A1 by TCDD by approximately >100 fold. Unfortunately, it isn't possible to derive an accurate and reliable EC_{50} from this data set, so comparison is subject to considerable inaccuracy. However, there is a large difference between curves, which is likely to be significant, although this can't be supported quantitatively.

3.4 The Effect of Time of Exposure on Induction of CYP1A1 RNA

3.4.1 Methodology

The standard induction assay used in this thesis exposes cells to chemical treatment for only four hours, on the basis that this minimises the effect of metabolism on the chemical. However, the effect of exposure time on induction of CYP1A1 has not been carefully examined. The hypothesis that longer exposure times would increase the apparent EC₅₀ (decrease the potency) of metabolically-labile chemicals, whilst not affecting the EC₅₀ of metabolically-resistant chemicals, was tested. RT-PCR was used (Section 3.1) with cells also been treated for 24 hours. Induction of CYP1A1 RNA by 3-MC was measured for both 4 and 24 hours and compared with TCDD which was also measured at 4 and 24 hours.

3.4.2 3-Methylcholanthrene

The induction of CYP1A1 RNA by 3-Methylcholanthrene (3-MC) was measured where cells were treated for 4 and 24 hours. Various concentrations (10 µM - 1 pM 3-MC) were compared against vehicle controls (VC) (controls were treated for either 4 or 24 hours, giving two sets). Gene quality evaluation values were 39% and 46% at 4 hours and 15% and 13% at 24 hours for AhR and β-Actin, respectively. The normalized response data was then plotted against concentration (Figure 3.21).

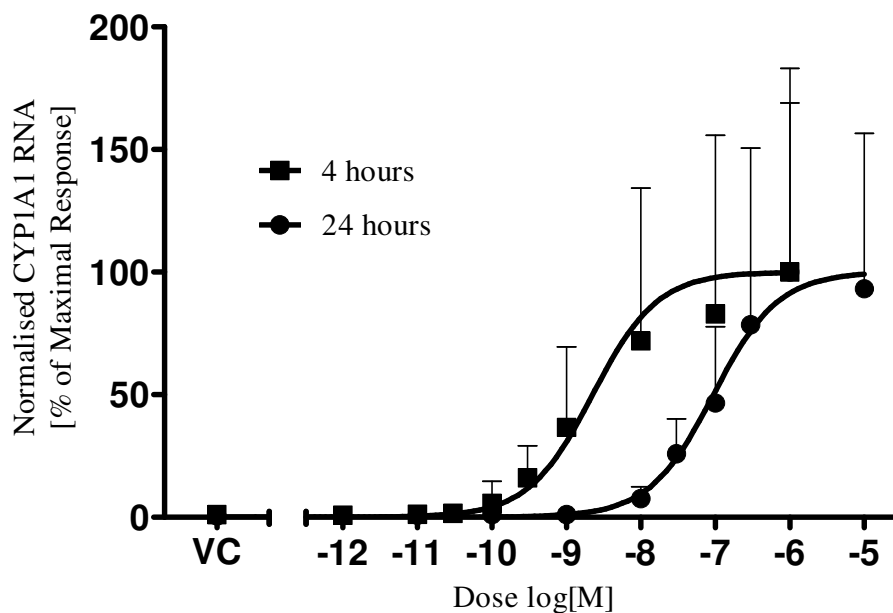

Figure 3.21: Induction of CYP1A1 RNA by 3-MC at 4 and 24 hours - H4-IIIEC3 cells were treated with the indicated dose of 3-MC, or vehicle control, for 4 or 24 hours, as described in materials and methods section 2.2.1. RNA was isolated from cells, and analysed for CYP1A1, β -Actin and AhR RNAs by real-time PCR, as described in section 2.2. CYP1A1 RNA was normalised using Qbase (section 2.2.5) against β -Actin and AhR RNAs, and then normalised to the maximum response, which is shown as 100%. Each curve has been individually normalised and then compared. The response of CYP1A1 against log dose is shown, and each point represents $n=3$ biological replicates, \pm S.D. VC: Vehicle control.

There is a significant difference in the potency of 3-MC between 4 and 24 hours. The EC_{50} after four hours treatment was 2.3 nM (95% CI = 1.3 nM-3.8 nM) and 94 nM (95% CI = 74 nM-120 nM) after 24 hours treatment. In agreement with the prior hypothesis, larger concentrations are required for maximal response at 24 hours in comparison to 4 hours, and this effect is substantial, with 3-MC being ~40-fold less potent at the later time point.

3.4.3 Tetrachlorodibenzo-*p*-dioxin

The induction of CYP1A1 RNA by TCDD when treated for 4 and 24 hours was analysed in order to establish whether metabolically stable compounds show a constant potency with time. Concentrations between 10 nM and 100 fM were used each time and compared against a vehicle control (VC). Figure 3.22 shows the induction of CYP1A1 RNA at each time. At 4 hours the gene evaluation values were 9% and 8% for β -Actin and AhR, respectively and at 24 hours they were 13% and 13%.

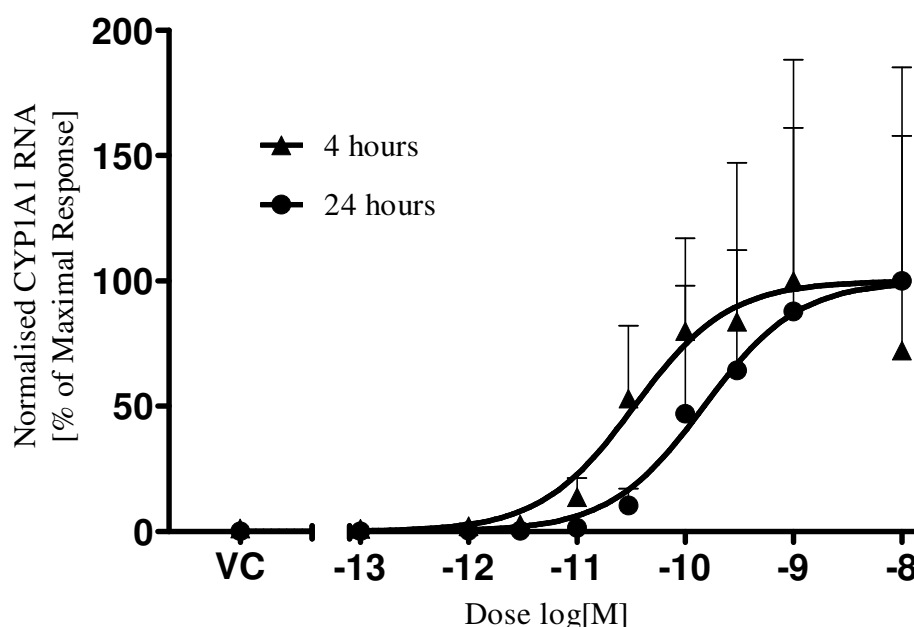

Figure 3.22: Induction of CYP1A1 RNA by TCDD at 4 and 24 hours - H4-IIIEC3 cells were treated with the indicated concentrations of TCDD in the presence and absence of 1 μ M DF 203. Cell treatment, RNA isolation and RT-PCR analysis was as described for Figure 3.20. The normalised response of CYP1A1 against log dose is shown, and each point represents n=3 biological replicates, \pm S.D. VC: Vehicle control.

At 4 hours the EC_{50} was 34 pM (95% = 18 pM-63 pM) and at 24 hours the EC_{50} was 149 pM (95% CI = 120 pM-185 pM), a difference of \sim 4 fold (Figure 3.22).

This demonstrates a significant increase in concentration required for induction between 4 and 24 hours, although this ~4-fold difference is smaller than the ~40-fold difference for 3-MC. These results demonstrate that time of exposure of cells to compound is a key variable that affects potency estimations.

4. Discussion

4.1 Measurement of CYP1A1

4.1.1 The Use of the H4-IIE Bioassay

Induction of CYP1A1 alone does not imply a toxic effect but instead works in parallel with other responses responsible for those toxic effects (Whyte *et al.*, 2004). Therefore care is required when using CYP1A1 induction to estimate the toxicity of a compound even though previous evidence confirms the parallel relationship between CYP1A1 induction and toxic effects (Safe, 1990). The H4-IIE bioassay method is useful for estimating the toxicity of HAHs in organisms but not so well for PAHs, as they are easily metabolised and don't bioaccumulate to the extent of HAHs. H4-IIE cells have low basal Aryl hydrocarbon hydroxylase (AHH) and CYP1A1 levels (Benedict *et al.*, 1973). The main advantage of H4-IIE cell models is that the treatment won't be effected by metabolism. Further advantages of *in vitro* models, with regards to *in vivo* models, are the high through-put and elimination of inter-animal differences.

4.1.2 CYP1A1 mRNA vs. EROD Enzyme Analysis

Quantitative analysis of the activation of AhR, through measurements of CYP1A1 RNA, is critically dependent on the methodology for RNA measurement. CYP1A1-associated enzymes, Ethoxyresorufin-O-deethylase (EROD) and Aryl hydrocarbon hydroxylase (AHH) are induced by TCDD-like compounds (Kennedy 1993). EROD activity has historically been used as a measure of AhR activation (; Clemons *et al.*, 1997, 1998; Hilscherova *et al.*, 2001; Peters *et al.*, 2004; Sanderson *et al.*, 1996; Schmitz *et al.*, 1995; Silkworth *et al.*, 2005). EROD

activity measures the rate of CYP1A1-mediated deethylation of 7-ethoxyresorufin (7-ER) leading to the production of highly-fluorescent resorufin, measured using a plate reader. The method replaced AHH activity in the mid 1980's due to the increased safety and economy of EROD, compared with AHH measurement. The system also has a greater efficiency and is much more cost effective (Whyte *et al.*, 2004). PCR technology has allowed the measurement of CYP1A1 RNA which provides a more sensitive measurement of AhR activation compared with EROD (Vanden Heuvel *et al.*, 1994). Research has shown that certain PCBs inhibit the EROD enzyme-substrate reaction making mixture experiments impossible to accurately measure, and illustrating the generic pitfall that enzyme activity measurement can be a flawed measure of AhR activation (Petrulis *et al.*, 1999). CYP1A1 RNA induction is one of the most potent effects of AhR activation so would be expected to give both the most accurate and most sensitive results. Measurement of resorufin requires that the cells are treated for longer periods of time to allow translation of the enzymes. Longer periods of treatment can lead to the metabolism of some compounds, including 3-MC (Riddick *et al.*, 1994) and TCDF (Clemons *et al.*, 1997). In this thesis a method of measuring the induction of CYP1A1 was calibrated using RT-PCR. Several variables that affect accurate measurement of CYP1A1 RNA were identified and optimised, yielding a methodology with considerable statistical power for the determination of the potency of an agonist for inducing CYP1A1 RNA. Statistical power is a prerequisite for detecting small differences in potency. Such quantitative measurement of induction potency enables the application of a variety of pharmacological tools to investigate the nature of agonism.

4.1.3 Reliability of Data

Several mechanisms were put in place to ensure the reliability of the data. Initially, the cDNA yield was normalised using Picogreen (Quanti-iT™ Picogreen® dsDNA assay kit). During PCR, three different controls confirmed that there was no DNA contamination, in both cDNA synthesis and RT-PCR analysis. Also during RT-PCR analysis, controls of 10 µM TCDD and vehicle were also run demonstrating no substantial differences between assays. The induction of CYP1A1 RNA was normalised against two reference genes, β-Actin and AhR, which were unaffected by any of the treatments used. Measurement of these reference genes was conducted on every sample alongside CYP1A1 as a way to normalise the levels of CYP1A1 RNA. The results of figure 3.5 show that neither of the reference genes, AhR and β-Actin, were affected by the vehicle or various concentrations of TCDD which proves that the cDNA used was of good quality and equal concentration within each sample.

The quality of the reference genes used for normalisation of CYP1A1 RNA was evaluated by Qbase, with the more reliable genes allocated a lower gene evaluation value. The gene evaluation value indicates how stably expressed the gene is with values of <50% considered reliable and higher values indicating less reliable results (Hellenmans *et al.*, 2007). The mean gene evaluation values for TCDD in this study were ~25% and ~33% for β-Actin and AhR, respectively, with similar values seen throughout the study with only a few exceptions, such as TCDF, that were >50%. The normalised data was used to produce a dose-response curve which allowed calculation of the EC₅₀. Comparison of EC₅₀ is a useful method but is only applicable when the dose-response curves are identically

positioned on the Y-axis, differing only in their position on the X-axis (Whyte *et al.*, 2004). The curves of four separate TCDD assays were compared to demonstrate the robustness of the method used and the reliability of the data collected. Multiple determinations of the EC₅₀ gave an average value of 35 pM (S.D. = ± 5.8 pM) with considerable overlap of means and 95% confidence intervals.

4.2 Partial Agonism studies

4.2.1 Agonist Properties

The results demonstrate that there were several compounds that are potent agonists of the AhR and induced CYP1A1 RNA with nanoMolar EC₅₀ values. It was possible to conclude from this data that, with the exception of CH 223191, all of the compounds tested had agonist properties since they induced CYP1A1 RNA.

4.2.2 Comparison of EC₅₀ with Previous Literature

The average EC₅₀ of TCDD found in this research was similar to that found by several other authors (Bazzi, 2008; Hilscherova *et al.*, 2001; Sanderson *et al.*, 1996; Schmitz *et al.*, 1995; Silkworth *et al.*, 2005). The majority of research summarised in table 3.1 was conducted in rat H4-IIIE cells, however there are several salient differences. The treatment times varied between 4 hours (Bazzi, 2008) and 72 hours (Hilscherova *et al.*, 2001), and another difference is the method of measurement used which, for the majority of studies, was measurement of EROD activity, with only two studies using RT-PCR (Bazzi, 2008; Silkworth *et al.*, 2005). The study by Silkworth *et al.* (2005) uses rat liver hepatocytes but

was included as a further example of an EC₅₀ found using a method more closely related to mRNA induction.

Compound with EC ₅₀ (95% CI) from this paper	Method ¹	EC ₅₀ (95% CI or SD/SE*) from literature	Author of literature
TCDD 35 pM (22 pM – 56 pM)	RT-PCR ^a	40 pM (± 13 pM*)	Bazzi 2008
	Invader	2.7 pM (1.2 pM – 5.9 pM) ^c	Silkworth 2005
	EROD ^c	41 pM (23 pM – 74 pM) ^c	Silkworth 2005
	EROD ^b	11.8 pM (± 3.9 pM*)	Clemons 1997
	EROD ^c	9.0 pM (± 2.1 pM)	Clemons 1998
	EROD ^d	34.5 pM (± 1.96 pM*)	Hilscherova 2001
	EROD	50 pM (± 13 pM*)	Schmitz 1995
	EROD ^d	10 pM	Peters 2004
EROD ^d	19.6 pM (± 5.6 pM*)	Sanderson 1996	
3-MC 2.3 nM (1.3 nM – 3.8 nM)	RT-PCR ^a	9 nM (7 nM – 13 nM)	Bazzi 2008
TCDF 5.8 nM (2.8 nM - 11 nM)	EROD ^b	45.0 pM (± 15.2 pM*)	Clemons 1997
PeCDF 2.2 nM (1.4 nM - 3.4 nM)	EROD ^d	76 pM (± 0.4 pM*)	Sanderson 1996
PCB 126 765 pM (645 pM - 907 pM)	Invader	1.5 nM (0.5 nM – 4.3 nM) ^c	Silkworth 2005
	EROD ^c	330 pM (110 pM – 990 pM) ^c	Silkworth 2005
	EROD ^d	264 pM (± 0.4 pM*)	Sanderson 1996
	EROD ^d	100 pM	Peters 2004
DF 203 1.5 μM (1.2 μM – 1.8 μM)	RT-PCR ^a	3 μM (0.9 μM – 13 μM)	Bazzi 2008

Table 4.1: Comparison of EC₅₀ with previous literature – ^a4 hours treatment, ^b24 hours treatment, ^c48 hours treatment, ^d72 hours treatment, ^eRat liver hepatocytes, *± Standard Deviation/Standard Error, Method¹: Method used in each experiment. RT-PCR: Real-time Polymerase Chain Reaction, EROD: Ethoxyresorufin-O-deethylation, Invader: RNA invader® invasive cleavage amplification assay (consists of an upstream oligonucleotide and a probe) see Silkworth *et al.* (2005).

4.2.2.1 TCDD, 3-MC and DF 203

TCDD is a well studied compound, used as a reference compound in many of the studies. The data shows that all the EC₅₀s from each paper are within a ~10-fold

difference of each other, with an average EC₅₀ of ~25 pM, which compares well with this paper (Average EC₅₀ = 35 pM). Bazzi (2008) assayed 3-MC and DF 203 with similar results to those found by this paper. The EC₅₀ for 3-MC in this paper was 5.8 nM (95% CI = 2.8 nM – 11 nM) which compares well to the findings of Bazzi (2008) which was 9 nM (95% CI = 7 nM – 13 nM). Furthermore, Bazzi (2008) found the EC₅₀ of DF 203 to be 3 μM (95% CI = 0.9 μM – 13 μM) which compared well with the EC₅₀ found in this paper which was 1.5 μM (95% CI = 1.2 μM -1.8 μM). This confirms the previous conclusion of other papers, that DF 203 has agonist properties (Bazzi, 2008; Loaiza-perez *et al.*, 2002).

4.2.2.2 TCDF and PeCDF

A 100-fold difference in the EC₅₀ for TCDF, in comparison with the literature, was found (Clemons *et al.*, 1997). Similarly, there is an 80-fold difference in the EC₅₀ found for PeCDF compared with the literature (Sanderson *et al.*, 1996). Calculation of the relative potency (REP) in relation to TCDD gave values of 0.006 and 0.016, for TCDF and PeCDF, respectively. This compares insufficiently with the WHO TEFs of 0.1 and 0.3 for TCDF and PeCDF, respectively. Review of the method reveals one possible explanation, in that the vehicle used to dissolve the compounds, was DMSO. In order to reduce the number of variables between experiments, the same solvent was used as a vehicle for each compound where possible. However, previous authors dissolved TCDF in *p*-dioxane (Bazzi, 2008) or isooctane (with further dilutions in DMSO) (Clemons *et al.*, 1997), with PeCDF also dissolved in isooctane (Sanderson *et al.*, 1996). Solubility of the compounds into the vehicle was only visually assessed and therefore complete solubility may not have occurred in DMSO. This would

mean the EC₅₀ estimates may show a higher concentration than in other research. This should not have any impact on agonism experiments other than the concentration used to give 15% of maximal induction would be lower than stated for TCDF and PeCDF. Another possible explanation for the differences seen between the EC₅₀ found in this paper and previous research is the use of RT-PCR instead of EROD activity. Clemons *et al.* (1997) found the EC₅₀ for TCDF only 1-2 fold higher than TCDD. Furthermore, Clemons *et al.* (1997) showed a ~7-fold increase in the EC₅₀ of the EROD activity of TCDF between exposures of 6 and 72 hours in H4-IIE Rat liver cells. In order to test the hypothesis that treatment duration affects the induction by TCDF, the effects at different exposure times could be assessed in a similar experiment as described in this paper (section 3.4).

4.2.2.3 PCB 126

The literature provided a wide range of values for the EC₅₀ of PCB 126 ranging from 100 pM (Peters *et al.*, 2004) to 1.5 nM (Silkworth *et al.*, 2005). The EC₅₀ found in this paper (765 pM) does lie comfortably within this range but with the majority of previous research utilising the EROD activity assay (Clemons *et al.*, 1998; Peters *et al.*, 2004; Sanderson *et al.*, 1996; Silkworth *et al.*, 2005), comparison is complex. The REP was calculated in relation to TCDD which was 0.05, compared with 0.1 predicted by the WHO TEF. Although lower than the WHO TEF, it does compare better with previous authors who measured 0.03 (Silkworth *et al.*, 2005) and 0.75 (Sanderson *et al.*, 1996) in rat liver hepatocytes and H4-IIE rat liver cells, respectively. Nevertheless, there is a slight discrepancy between research found in this paper and that published by the WHO. In this paper, PCB 126 was dissolved in DMSO as described by previous authors (Clemons *et al.*, 1998; Silkworth *et al.*, 2005), although Sanderson *et al.* (1996)

used isooctane as a vehicle, presumably to reduce the number of variables. The slight discrepancy between values could therefore be due to the method of measurement (EROD activity) which was shown to be inhibited by other PCBs (Clemons *et al.*, 1998) however there is no previous evidence of this.

4.2.3 Effects of Partial Agonism on CYP1A1 RNA Induction

The four agonists that were tested, 3-MC, TCDF, PeCDF and PCB 126, showed no antagonistic properties in the particular experiments carried out in this study. Clemons *et al.* (1998) tested TCDD in the presence of various PCBs including PCB 126 and found that the compound also had no effect on induction by TCDD (Clemons *et al.*, 1998). Walker *et al.* (2005) conducted mixture experiments in rats with the occurrence of neoplastic and nonneoplastic effects as an endpoint. Although the WHO additivity method was not directly applied, the authors did conclude that PCB 126 had no observable partial agonistic effects.

By comparing the 95% confidence intervals of the EC₅₀ from each partial agonism experiment with that of TCDD alone it can be concluded that there was no significant difference in the concentrations of TCDD required for CYP1A1 RNA induction. This shows that the four agonist compounds tested do not have detectable antagonist properties in rat H4-IIIEC3 cells, when compared with TCDD. If the compounds tested had an effect on the concentrations of TCDD required for induction; a shift of the dose-response curve to the right would be observed in a similar way to figure 3.14 (1 µM DF 203) and figure 3.16 (10 µM CH 233191). The EC₅₀ determinations have 95% confidence intervals spanning a 3-5 fold range, and so these experiments are sufficiently powered to detect antagonism that shifts the EC₅₀ of TCDD by ~5-fold. A compound with a high

intrinsic efficacy does not need to bind to as many receptors as a compound with a low intrinsic efficacy, such as a partial agonist, to reach the same response (Kenakin, 1997). Given the comparatively low dose of potential antagonist tested (~15% of maximal induction), a compound would need to have intrinsic efficacy which is >90% antagonistic to be detected in this assay.

4.2.4 Partial agonism by DF 203

The agonist only curve confirms previous research that describes DF 203 as having agonist properties (Bazzi, 2008; Loaiza-perez *et al.*, 2002). Induction of CYP1A1 by TCDD in the presence of 1 μ M DF 203 demonstrated that the compound had partial agonistic properties. Research by Bazzi (2008) demonstrated that DF 203 had a high binding affinity (K_i) but low efficacy. This difference between affinity and efficacy could be explained by DF 203 having antagonistic properties. From the dose-response curve in figure 3.16, this concentration should be ~300 nM DF 203, however this provided no change in induction when in the presence of TCDD (Figure 3.17), indicating that the concentration was too low to induce CYP1A1 RNA (i.e. 15% of maximal response) which one would assume was therefore also too low to antagonise TCDD. A second dose-response curve was then established using a higher concentration of 1 μ M DF 203 (Figure 3.18). In this case, it would appear that the estimation of 15% of maximal response is too high but comparable to that of the original agonist only dose-response curve, which is also supported by previous research (Bazzi 2008). It was possible to calculate the EC_{50} of the curve which was 726 pM (95% CI = 69 pM-7.6 nM) which was found to be significantly different from TCDD alone (EC_{50} = 34 pM, 95% CI = 18 pM - 63 pM). It is therefore possible to conclude that this compound has both agonist and antagonist

properties. The fact that DF 203 has been shown to have antagonistic properties is a novel finding not tested previously. Bazzi (2008) assayed a congener of DF 203 known as 5F 203, which is also an experimental synthetic anti-tumour agent. Bazzi (2008) calculated the EC_{50} for 5F 203 to be $3\mu\text{M}$ (95% CI = $1.3\mu\text{M} - 7.7\mu\text{M}$), similar to the EC_{50} for DF 203, also demonstrating that it had agonistic properties but with a low potency compared with TCDD (Bazzi 2008). Furthermore, the K_i was found to be 2.8 nM ($2\text{ nM} - 5\text{ nM}$) which is 5-fold lower than the K_i for DF 203 (9.9 nM), suggesting that 5F 203, is a slightly stronger antagonist than DF 203. In agreement with this, Bazzi (2008) found that $1\mu\text{M}$ 5F 203 shifted the TCDD dose-response curve by ~ 100 -fold, whereas this report finds that $1\mu\text{M}$ DF 203 shifted the TCDD dose-response curve by ~ 20 -fold. Thus the empirical finding is that DF 203 has slightly lesser antagonist properties than 5F 203.

4.2.5 Antagonistic properties of CH 223191

The inhibition of TCDD to induce CYP1A1 RNA by CH 223191 was measured. Figure 3.20 shows treatment with TCDD in the presence of $10\mu\text{M}$ CH 223191 however the concentrations of TCDD required for induction are too low to allow calculation and comparison of the EC_{50} . Potentially it is possible to compare the two curves (TCDD in presence and absence of CH 223191) and see that there is a considerable shift of the curve to the right which would indicate antagonism of TCDD however it isn't possible to quantify this with the given data. Figure 3.19 shows that when 300 nM CH 223191 was added to TCDD treated cells, the antagonist had little or no observable effect of induction of CYP1A1 RNA by TCDD, even though an effect was observed by Kim *et al.* (2006). There are two

major factors that might explain this difference. Firstly, HepG2 human hepatoma cells were tested instead of H4-IIIE rat liver cells and secondly, cells were pre-treated with CH 223191, one hour before treatment with TCDD, which was not done in this paper. This could explain the discrepancy seen when treating cells with 300 nM CH 223191, which should have produced an effect according to data from Kim *et al.* (2006) but in this paper had no observable antagonistic effects (figure 3.19). Furthermore, Kim *et al.* (2006) measured a single concentration of TCDD in the presence of only three concentrations of CH 223191, visualised using Reverse Transcriptase-PCR, which can be quite inaccurate and unreliable.

4.3 Time Dependent Induction Assays

4.3.1 3-Methylcholanthrene vs. 2,3,7,8-Tetracholodibenzo-*p*-dioxin

Previous authors (Poland *et al.*, 1974; Riddick *et al.*, 1994; Sekimoto *et al.*, 2004; Xu *et al.*, 2005) have described 3-MC as being metabolised rapidly by P450 enzymes. In the time-dependent induction assay conducted in this paper, cells were treated with 3-MC at various concentrations for 4 hours and 24 hours. The EC₅₀s were calculated for each curve and compared, demonstrating a 40-fold significant difference with no overlapping of the 95% confidence intervals. This difference in induction thresholds between 4 and 24 hours could be due to a variety of factors including; metabolism of the ligand, degradation of CYP1A1 RNA over time or reduction in AhR-mediated induction of CYP1A1 RNA. Firstly, 3-MC has a reported half-life of ~16 hours in rats (Aitio *et al.*, 1974) although no experimental work has actually quantified the half-life in H4IIIE cells, research does show a decrease of the half-life of 3-MC compared with TCDD (Aitio *et al.*, 1979). Nevertheless using this estimation as a guide, a reduction of

~40% of 3-MC could be expected in cells over a period of 24 hours. Therefore it could be concluded that this will have a huge impact in the reduction of the induction of CYP1A1 RNA by 3-MC between 4 and 24 hours. Cells were also treated with TCDD in a separate experiment for 4 and 24 hours to allow comparison to 3-MC. TCDD has a half life of 17-31 days in rats (Van den Berg *et al.*, 1994) so metabolism would not be expected to affect induction of CYP1A1 RNA. However despite this, a 4-fold significant difference in TCDD induced CYP1A1 RNA levels was found between 4 and 24 hours. Other literature shows no significant change in EC₅₀ of TCDD up to 72 hours after treatment (Bazzi, 2008; Clemons *et al.*, 1997). The important advantage of this study over previous work (Bazzi, 2008) is the greater statistical power for estimating the EC₅₀ produced from the increased number of concentrations utilised and the use of simultaneous normalisation of CYP1A1 RNA against the two reference genes. This would make the method used in this paper more adept at observing minute changes in induction. Another explanation for this discrepancy is that TCDD is known to be lipophilic so over 24 hours, TCDD may have fallen slightly out of solution or more likely adsorbed to the 96-well plate or even the densely packed lipids making up the cell membrane.

With the data collected, it isn't possible to comment on the mechanism by which CYP1A1 RNA levels decreased with regards to TCDD. However, the degradation of CYP1A1 RNA or the reduction in AhR-mediated induction of CYP1A1 RNA may have an important role. Theoretically there must be a system within the cell to remove un-necessary RNA. Recent studies have described small interfering RNAs (siRNA) which degrade RNA and interfere with the expression of a specific gene (Hannon *et al.*, 2004). Reduction of CYP1A1 could be attributed to

naturally occurring siRNAs, as well as the ligand being metabolised by P450 enzymes over time. Another explanation is that there may be a reduction in the initial AhR-mediated induction of CYP1A1. This reduction could be attributed to any one of the stages of the mechanism of action; however it would seem conceivable that the quantity of AhR may decrease quickly in the presence of a high concentration of a specific AhR ligand, which would in turn decrease the induction of CYP1A1 RNA. Giannone and co-workers (1998) confirmed that the AhR population rapidly decreases following treatment with TCDD and can remain low for at least 24 hours after exposure has ended (Giannone *et al.*, 1998), however the authors did acknowledge the fact that CYP1A1 levels remained constant 72 hours after treatment despite reduced AhR levels. Superinduction appears to show an increase in response as CYP1A1 RNA levels build up because protein translation is inhibited (Ma *et al.*, 2000). Ma *et al.*, (2000) demonstrated this using three compounds which increased the induction of CYP1A1 by TCDD, two of which work by inhibiting AhR degradation (Ma *et al.*, 2000) showing the effect of reducing the depletion of AhR, at least in the presence of certain other compounds, can maintain CYP1A1 levels. Consequently, although the data required to make a reliable conclusion is not available, it can be hypothesized that both of these additional reasons for a decrease in AhR activity, could be associated with the differences observed between 4 and 24 hours in TCDD with the large addition of metabolism affecting 3-MC. Future work would reconfirm the values found for the two agonists and would look into explanations for differences in AhR binding and degradation.

4.4 Bioassay Limitations and Future Use

4.4.1 Limitations of assays

This paper looked at potential antagonist compounds individually or in a mixture with only TCDD. In the environment, these compounds will be in complex mixtures with a large variety of dioxin-like and non dioxin-like compounds, and therefore the compounds tested could behave differently. It isn't realistic to measure the interaction between every compound or to measure every conceivable mixture variation however using this data may allow the estimation of the characteristics of a particular compound in a given situation. This is what makes the TEQ system such a powerful risk assessment tool by collecting data similar to this paper on individual compounds or small mixtures, and using it to predict how the compound will act in a complex mixture. Furthermore, assays were performed under control conditions in H4-IIIEC3 bioassays which may not be fully representative of how the compounds may interact *in vivo*.

The benefits of using H4-IIE cells are well researched including excellent growth properties, low basal AHH and CYP1A1 levels, with a high degree of responsiveness towards dioxin-like compounds (Benedict *et al.*, 1973). Research by Niwa *et al.* (1975) demonstrated the extreme potency of TCDD in H4-IIE cells (Niwa *et al.*, 1975). Authors have shown comparative results from H4-IIE cells to structure-activity relationships, binding assays and *in vivo* responses in rats (Safe, 1986) furthermore H4-IIE cells have high levels of AhR. In this paper the effects of AhR antagonists were assayed, however as previously discussed a compound with antagonistic properties will bind to the Ah receptor but will not activate it. Therefore by choosing a cell line with decreased number of Ah receptor,

observation of antagonistic effects may become more easily detectable. A comprehensive study in rat cell lines showing levels of Ah receptor has not been conducted previously, however cell types with low levels of AhR include brain, kidney and skeletal muscles as demonstrated by Dolwick *et al.* (1993) in human tissues (Dolwick *et al.*, 1993).

4.4.2 Future application of bioassay

There are several PCBs which exhibit both agonistic and antagonistic properties which could be further investigated in relation to risk assessment and the additivity approach (Chu *et al.*, 2001; Clemons *et al.*, 1998; Schmitz *et al.*, 1995). Clemons *et al.* (1998) combined various concentrations of TCDD with different PCBs and showed that some of the PCBs had antagonistic effects which would produce a lower toxic potency than that predicted by the TEQ additivity approach. This conclusion was further complicated by the differing effects of antagonistic PCBs in complex mixtures of HAHs. Other compounds not currently included within the WHO TEQ compounds, such as polybrominated diphenylethers (PBDEs), could also have implications on risk assessment in complex environmental mixtures. Peters *et al.* (2004) measured TCDD in the presence of various PBDEs and found that several of the compounds had inhibitory effects, producing a significantly lower response than TCDD alone. These would potentially affect the TEQ estimation if not accounted for. A more detailed investigation of naturally occurring agonists should be conducted.

4.5 Conclusion

The aim of this paper was to observe and where possible, quantitate the antagonistic effects for several of the most potent and prevalent dioxin-like AhR

ligands. It was found that the four agonists tested did not have antagonistic properties however this paper has successfully demonstrated the antagonistic properties of DF 203, when in the presence of TCDD. Furthermore, the antagonistic effects of CH 223191 on the induction of CYP1A1 RNA by TCDD was verified and confirmation of a decrease in the ability to activate the AhR over time by 3-MC was demonstrated. The method designed for measuring the activation of the AhR by different agonists was successfully applied to all of the compounds used in this experiment. RT-PCR, with increased sensitivity of CYP1A1, decreasing costs and faster output; should become the default method for measurement in the future. Furthermore, investigation into the bioassay may improve the observation of antagonistic effects with increased knowledge of compound metabolism derived from the induction measured at different exposure times. Finally, future work will need to analyse the potential effects of natural ligands, as well as partial agonists, on the TEQ calculated using the additivity approach.

References

- Ahlborg, U.G., G.C Becking, L.S. Birnbaum, A. Brouwer, H.J.G.M. Derks, M. Feeley, G. Color, A. Hanberg, J.C. Larsen, A.K.D. Liem, S.H. Safe, C. Schlatter, F. Wvorn, M. Younes and E. Yrjanheikki (1994). "Toxic Equivalency Factors for Dioxin-Like PCBs, Report on a WHO-ECEH and IPCS Consultation, December 1993." Chemosphere **28**(6): 1049-1067.
- Aitio, A. (1974). "Different Elimination and Effect on Mixed Function Oxidase of 20-Methyl-cholanthrene after Intra gastric and Intraperitoneal Administration." Research Communications in Chemical Pathology and Pharmacology **9**(4): 701-710.
- Aylward, L. L., J.C. Lamb and S.C. Lewis (2005). "Issues in Risk Assessment for Developmental Effects of 2,3,7,8-Tetrachlorodibenzo-*p*-dioxin and Related Compounds." Toxicological Sciences **87**(1): 3-10.
- Bazzi, R. (2008). Pharmacological interactions between phenylbenzothiazoles and Aryl Hydrocarbon Receptor (AhR). School of Biology, University of Nottingham.
- Bell, D. R. and A. Poland (2000). "Binding of aryl hydrocarbon receptor (AhR) to AhR interacting protein. The role of hsp90." Journal of Biological Chemistry **275**(46): 36407-36414.
- Bell, D. R., S. Clode, M. Qi Fan, A. Fernandes, P. M. D. Foster, T. Jiang, G. Loizou, A. MacNicoll, B. G. Millerl, M. Rose, L. Tran and S. White (2007). "Relationships between Tissue Levels of 2,3,7,8-Tetrachlorodibenzo-*p*-dioxin (TCDD), mRNAs, and Toxicity in the Developing Male Wistar(Han) Rat." Toxicological Sciences **99**(2): 591-604.
- Benedict, W. F., N. Considine and D.W. Nebert (1973). "Genetic Differences in Aryl Hydrocarbon Hydroxylase Induction and Benzo[a]pyrene-Produced Tumorigenesis in the Mouse." Molecular Pharmacology **6**: 266-277.
- Bertazzi, P. A., C. Zocchetti, A.C. Pesatori, S. Guercilena, M. Sanarico and L. Radice (1989). "Ten-year Mortality Study of the Population Involved in the Seveso Incident in 1976." American Journal of Epidemiology **129**(6): 1187-1200.
- Birnbaum, L. S., G.M. Decad and H.B. Matthews (1980). "Disposition and Excretion of 2,3,7,8-Tetrachlorodibenzofuran in the Rat." Toxicology and Applied Pharmacology **55**: 342-352.
- Bjeldanes, L. F., J.-Y. Kim, K.R. Grose, J.C. Bartholomew and C. A. Bradfield (1991). "Aromatic Hydrocarbon Responsiveness-Receptor Agonists Generated from Indole-3-Carbinol *in Vitro* and *in Vivo*: Comparisons with 2,3,7,8-Tetrachlorodibenzo-*p*-Dioxin." Proceedings of the National Academy of Sciences of USA **88**: 9543-9547.

- Budinsky, R. A., D. Paustenbach, D. Fontaine, B. Landenberger and T.B. Starr (2006). "Recommended Relative Potency Factors for 2,3,4,7,8-Pentachlorodibenzofuran: The Impact of Different Dose Metrics." Toxicological Sciences **91**(1): 275-285.
- Calderone, V. (1998). "An Alternative Method to Evaluate the Nature of an Antagonist and Its Potency: A Theoretical Approach." Journal of Pharmacological and Toxicological Methods **39**: 129-135.
- Casper, R. F., M. Quesne, I.M. Rogers, T. Shirota, A. Jolivet, E. Milgrom and JF. Savouret (1999). "Resveratrol Has Antagonist Activity on the Aryl Hydrocarbon Receptor: Implications for Prevention of Dioxin Toxicity." The American Society for Pharmacology and Experimental Therapeutics **56**: 784-790.
- Chu, I., P. Lecavalier, H. Hakansson, A. Yagminas, V.E. Valli, P. Poon and M. Feeley (2001). "Mixture Effects of 2,3,7,8-Tetrachlorodibenzo-*p*-dioxin and Polychlorinated Biphenyl Congeners in Rats." Chemosphere **43**: 807-814.
- Chua, M.-S., E. Kashiyaama, T.D. Bradshaw, S.F. Stinson, E. Brantley, E.A. Sausville and M.F.G. Stevens (2000). "Role of CYP1A1 in Modulation of Antitumor Properties of the Novel Agent 2-(4-Amino-3-methylphenyl)benzothiazole (DF 203, NSC 674495) in Human Breast Cancer Cells." Cancer Research **60**: 5196-5203.
- Ciolino, H. P., P.J. Daschner and G.C. Yeh (1998). "Resveratrol Inhibits Transcription of CYP1A1 in Vitro by Preventing Activation of the Aryl Hydrocarbon Receptor." Cancer Research **58**: 5707-5712.
- Clemons, J. H. D., G. Dixon and N.C. Bols (1997). "Derivation of 2,3,7,8-TCDD Toxic Equivalent Factors (TEFs) for Selected Dioxins, Furans and PCBs with Rainbow Trout and Rat Liver Cell Lines and the Influence of Exposure Time." Chemosphere **34**(5-7): 1105-1119.
- Clemons, J. H., C.R. Myers, L.E.J. Lee, D.G. Dixon and N.C. Bols (1998). "Induction of Cytochrome P4501A by Binary Mixtures of Polychlorinated Biphenyls (PCBs) and 2,3,7,8-Tetrachlorodibenzo-*p*-dioxin (TCDD) in Liver Cell Lines from Rat and Trout." Aquatic Toxicology **43**: 179-194.
- Denison, M. S., J.M. Fisher and J.P. Whitlock, Jr. (1988a). "The DNA Recognition Site for the Dioxin-Ah Receptor Complex." The Journal of Biological Chemistry **263**(33): 17221-17224.
- Denison, M. S., J.M. Fisher and J.P. Whitlock, Jr. (1988b). "Inducible, Receptor-dependent Protein-DNA Interactions at a Dioxin-responsive Transcriptional enhancer." Proceedings of the National Academy of Sciences **85**: 2528-2532
- Denison, M. S., A. Pandini, S.R. Nagy, E.P. Baldwin and L. Bonati (2002). "Ligand binding and activation of the Ah receptor." Chemico-Biological Interactions **141**: 3-24.

- Denison, M. S. and S. R. Nagy (2003). "Activation Of The Aryl Hydrocarbon Receptor By Structurally Diverse Exogenous And Endogenous Chemicals." Annual Review of Pharmacology and Toxicology **43**: 309-334.
- DeVito, M. J. and L. S. Birnbaum (1995). "The Importance of Pharmacokinetics in Determining the Relative Potency of 2,3,7,8-Tetrachlorodibenzo-*p*-dioxin and 2,3,7,8-Tetrachlorodibenzofuran." Fundamental and Applied Toxicology **24**: 145-148.
- Dolwick, K. M., J.V. Schmidt, L.A. Carver, H.I. Swanson and C.A. Bradfield (1993). "Cloning and Expression of a Human Ah Receptor cDNA." Molecular Pharmacology **44**(5): 911-917.
- Elferink, C. J. (2003). "Aryl Hydrocarbon Receptor-mediated Cell Cycle Control." Progress in Cell Cycle Research **5**: 261-267.
- Ema, M., N. Ohe, M. Suzuki, J. Mimura, K. Sogawa, S. Ikawa and Y. Fujii-Kuriyama (1994). "Dioxin Binding Activities of Polymorphic Forms of Mouse and Human Aryl hydrocarbon Receptors." The American Society for Biochemistry and Molecular Biology **269**(44): 27337-27343.
- Fattore, E., C. Trossvik and H. Håkansson (2000). "Relative Potency Values Derived from Hepatic Vitamin A Reduction in Male and Female Sprague-Dawley Rats Following Subchronic Dietary Exposure to Individual Polychlorinated Dibenzo-*p*-dioxin and Dibenzofuran Congeners and a Mixture Thereof." Toxicology and Applied Pharmacology **165**: 184-194.
- Gillner, M., J. Bergman, C. Cambillau, B. Fernstrom and J-A. Gustafsson (1985). "Interactions of Indoles with Specific Binding Sites for 2,3,7,8-Tetrachlorodibenzo-*p*-dioxin in Rat Liver." Molecular Pharmacology **28**: 357-363.
- Giunnone, J. V., W. Li, M. Probst and A.B. Okey (1998). "Prolonged Depletion of AH Receptor without Alteration of Receptor mRNA Levels after Treatment of Cells in Culture with 2,3,7,8-Tetrachlorodibenzo-*p*-dioxin." Biochemical Pharmacology **55**: 489-497.
- Hamm, J. T., C.-Y. Chen and L.S. Birnbaum (2003). "A Mixture of Dioxins, Furans, and Non-ortho PCBs Based upon Consensus Toxic Equivalency Factors Produces Dioxin-Like Reproductive Effects." Toxicological Sciences **74**: 182-191.
- Hankinson, O. (1995). "The Aryl Hydrocarbon Receptor Complex." Annual Review of Pharmacology and Toxicology **35**: 307-340.
- Hannon, G. J. and J. J. Rossi (2004). "Unlocking the Potential of the Human Genome with RNA Interference." Nature **431**: 371-378.
- Harper, P.A., J.M.Y. Wong, M.S.M. Lam and A.B. Okey (2002). "Polymorphisms in the Human Ah Receptor." Chemico-Biological Interactions **141**: 161-187.

- Haws, L.C., S.H. Su, M. Harris, M.J. DeVito, N.J. Walker, W.H. Farland, B. Finley and L.S. Birnbaum (2006). "Development of a Refined Database of Mammalian Relative Potency Estimates for Dioxin-like Compounds." Toxicological Sciences **89**(1): 4-30.
- Hellemans, J., G. Mortier, A.D. Paepe, F. Speleman and J. Vandesompele (2007). "Qbase Relative Quantification Framework and Software for Management and Automated Analysis of Real-Time Quantitative PCR Data." Genome **8**(2): 1-19
- Henry, E. C., A.S. Kende, G. Rucci, M.J. Totleben, J.J. Willey, S.D. Dertinger, R.S. Pollenz, J.P. Jones and T.A. Gasiewicz (1999). "Flavone Antagonists Bind Competitively with 2,3,7,8-Tetrachlorodibenzo-*p*-Dioxin (TCDD) to the Aryl Hydrocarbon Receptor But Inhibit Nuclear Uptake and Transformation." Molecular Pharmacology **55**: 716-725.
- Hilscherova, K., K. Kannan, Y-S. Kang, I. Holoubek, S. M. M. Machala, J. Nakanishi and J.P. Giesy (2001). "Characterization Of Dioxin-Like Activity Of Sediments From A Czech River Basin." Environmental Toxicology and Chemistry **20**(12): 2768-2777.
- Hord, N. G. and G. H. Perdew (1994). "Physicochemical and Immunocytochemical Analysis of the Aryl Hydrocarbon Receptor Nuclear Translocator: Characterization of Two Monoclonal Antibodies to the Aryl Hydrocarbon Receptor Nuclear Translocator." Molecular Pharmacology, **46**(4): 618-626.
- Jenkinson, D. H., E.A. Barnard, D. Hoyer, P.P.A. Humphrey, P. Leff and N.P. Shankley (1995). "International Union of Pharmacology Committee on Receptor Nomenclature and Drug Classification. IX. Recommendations on Terms and Symbols in Quantitative Pharmacology." The American Society for Pharmacology and Experimental Therapeutics **47**(2): 255-266.
- Jones, K. W. and J. P. Whitlock, Jr (1990). "Functional Analysis of the Transcriptional Promoter for the CYP1A1 Gene." Molecular and Cellular Biology: 5098-5105.
- Kahn, P. C., M. Gochfeld, M. Nygren, M. Hansson, C. Rappe, H. Velez, T. Ghent-Guenther and W.P. Wilson (1988). "Dioxins and Dibenzofurans in Blood and Adipose Tissue of Agent Orange-exposed Vietnam Veterans and Matched Controls." The Journal of the American Medical Association **259**(11): 1661-1667.
- Kenakin, T. P. (1997). Pharmacologic Analysis of Drug-Receptor Interaction. USA, Lippincott-Raven Publishers.
- Kennedy, S. W., A. Lorenzen, C.A. James and B.T. Collins (1993). "Ethoxyresorufin-O-deethylase and Porphyrin Analysis in Chicken Embryo Hepatocyte Cultures with a Fluorescence Multiwell Plate Reader." Analytical Biochemistry **211**: 102-112.

- Kim, S.-H., E.C. Henry, D-K. Kim, Y-H Kim, K.J. Shin, M.S. Han, T.G. Lee, J-K. Kang, T.A. Gasiewicz, S.H. Ryu and P-G Suh (2006). "Novel Compound 2-Methyl-2H-pyrazole-3-carboxylic Acid (2-methyl-4-o-tolylazo-phenyl)-amide (CH-223191) Prevents 2,3,7,8-TCDD-Induced Toxicity by Antagonizing the Aryl Hydrocarbon Receptor." Molecular Pharmacology **69**: 1871-1878.
- Loaiza-Perez, A. I., V. Trapani, C. Hose, S.S. Singh, J.B. Trepel, M.F.G. Stevens, T.D. Bradshaw and E.A. Sausville (2002). "Aryl Hydrocarbon Receptor Mediates Sensitivity of MCF-7 Breast Cancer Cells to Antitumor Agent 2-(4-Amino-3- methylphenyl) Benzothiazole." Molecular Pharmacology **61**: 13-19.
- Lusska, A., L. Wu and J.P. Whitlock (1992). "Superinduction of CYP1A1 Transcription by Cycloheximide." The Journal of Biological Chemistry **267**(21): 15146-15151.
- Ma, Q., A.J. Renzelli, K.T. Baldwin and J.M. Antonini (2000). "Superinduction of CYP1A1 Gene Expression - Regulation of 2,3,7,8-Tetrachlorodibenzo-*p*-dioxin-Induced Degradation of Ah Receptor by Cycloheximide." The Journal of Biological Chemistry **275**(17): 12676-12683.
- Malins, D. C., K.M. Anderson, N.K. Gilman, V.M. Green, E.A. Barker and K.E. Hellstrom (2004). "Development of a Cancer DNA Phenotype Prior to Tumor Formation." Proceedings of the National Academy of Sciences of USA **101**(29): 10721-10725.
- Manz, A., J. Berger , J.H. Dwyer, D. Flesch-Janys, S. Nagel and H. Waltsgott (1991). "Cancer mortality among workers in chemical plant contaminated with dioxin." Lancet **338**(8773): 959-964.
- Masuda, Y. (1985). "Health Status of Japanese and Taiwanese after Exposure to Contaminated Rice Oil." Environmental Health Perspectives **60**: 321-325.
- Okey, A. B. and L. M. Vella (1982). "Binding of 3-Methylcholanthrene and 2,3,7,8-Tetrachlorodibenzo-*p*-dioxin to a Common Ah Receptor Site in mouse and Rat Hepatic Cytosols." European Journal of Biochemistry **127**(1): 39-47.
- Park, J. K., M.K. Shigenaga and B.N. Ames (1996). "Induction of cytochrome P4501A1 by 2,3,7,8-tetrachlorodibenzo-*p*-dioxin or indolo(3,2-b)carbazole is associated with oxidative DNA damage." Proceedings of the National Academy of Sciences **93**: 2322-2327.
- Peters, A. K., K. Van Londen, A. Bergman, J. Bohonowych, M.S. Dension, M. Van den Berg and J.T. Sanderson (2004). "Effects of Polybrominated Diphenyl Ethers on Basal and TCDD-Induced Ethoxyresorufin Activity and Cytochrome P450-1A1 Expression in MCF-7, HepG2 and H4IIE Cells." Toxicological Sciences **82**: 488-496.

- Petrulis, J. R. and N. J. Bunce (1999). "Competitive Inhibition by Inducer as a Confounding Factor in the Use of the Ethoxyresorufin-O-deethylase (EROD) Assay to Estimate Exposure to Dioxin-like Compounds." Toxicology Letters **105**: 251-260.
- Phelan, D., G.M. Winter, W.J. Rogers, J.C. Lam and M.S. Denison (1998). "Activation of the Ah Receptor Signal Transduction Pathway by Bilirubin and Biliverdin." Archives of Biochemistry and Biophysics **357**(1): 155-163.
- Pohjanvirta, R., M. Unkila, J. Linden, J.T. Tuomisto and J. Tuomisto (1995). "Toxic equivalency factors do not predict the acute toxicities of dioxins in rats." European Journal of Pharmacology **293**: 341-353.
- Poland, A., E. Glover, and A.S. Kende (1976). "Stereospecific, High Affinity Binding of 2,3,7,8-Tetrachlorodibenzo-*p*-dioxin by Hepatic Cytosol. Evidence that the Binding Species is Receptor for Induction of Aryl Hydrocarbon Hydroxylase." Journal of Biological Chemistry **251**(16): 4936-4946.
- Poland, A. and E. Glover. (1974). "Comparison of 2,3,7,8-Tetrachlorodibenzo-*p*-dioxin, a potent inducer of Aryl Hydrocarbon Hydroxylase, with 3-Methylcholanthrene." Molecular Pharmacology **10**: 349-359.
- Poland, A. and J. C. Knutson. (1982). "2,3,7,8-Tetrachlorodibenzo-*p*-dioxin and Related Halogenated Aromatic Hydrocarbons: Examination of the Mechanism of Toxicity." Annual Review of Pharmacology and Toxicology **22**: 517-554.
- Pollenz, R. S., C.A. Sattler and A. Poland (1994). "The Aryl Hydrocarbon Receptor and Aryl Hydrocarbon Receptor Nuclear Translocator Protein Show Distinct Subcellular Localizations in Hepa 1c1c7 Cells by Immunofluorescence Microscopy." Molecular Pharmacology **45**(3): 428-438.
- Probst, M. R., S. Reisz-Porszasz, R.V. Agbunag, M.S. Ong and O. Hankinson (1993). "Role of the Aryl Hydrocarbon Receptor Nuclear Translocator Protein in Aryl Hydrocarbon (Dioxin) Receptor Action." Molecular Pharmacology **44**(3): 511-518.
- Riddick, D. S., Y. Huang, P.A. Harper and A.B. Okey (1994). "2,3,7,8-Tetrachlorodibenzo-*p*-dioxin *Versus* 3-Methylcholanthrene: Comparative Studies of Ah Receptor Binding, Transformation, and Induction of CYP1A1." The Journal of Biological Chemistry **269**(16): 12118-12128.
- Safe, S. H. (1986). "Comparative Toxicology And Mechanism Of Action Of Polychlorinated Dibenzo-*p*-Dioxins And Dibenzofurans." Annual Review of Pharmacology and Toxicology **26**: 371-399.

- Safe, S. H. (1990). "Polychlorinated Biphenyls (PCBs), Dibenzo-p-Dioxins (PCDDs), Dibenzofurans (PCDFs), and Related Compounds: Environmental and Mechanistic Considerations Which Support the Development of Toxic Equivalency Factors (TEFs)" Critical Reviews in Toxicology **21**(1): 51-88.
- Safe, S. H. (1998). "Hazard and Risk Assessment of Chemical Mixtures Using the Toxic Equivalency Factor Approach." Environmental Health Perspectives **106**(Supplement 4): 1051-1058.
- Sanderson, J. T., J.M.M.J.G. Aarts, A. Brouwer, K.L. Froese, and M. S. Denison and J. P. Giesy (1996). "Comparison of Ah Receptor-Mediated Luciferase and Ethoxyresorufin- O-deethylase Induction in H4IIE Cells: Implications for Their Use as Bioanalytical Tools for the Detection of Polyhalogenated Aromatic Hydrocarbons." Toxicology and Applied Pharmacology **137**: 316-325.
- Schechter, A., L.C. Dai, L.T Bich Thuy, H. Trong Quynh, D. Quang Minh, H. Dinh Cau, P. Hoang Phiet, N.T. Ngoc Phluong, J.D. Constable, R. Baughman, O. Papke, J. J. Ryan, P. Furst and S. Raisanen (1995). "Agent Orange and the Vietnamese: The Persistence of Elevated Dioxin Levels in Human Tissues." American Journal of Public Health **85**(4): 516-522.
- Schmitz, H.-J., A. Hagenmaiera, H-P. Hagenmaierb, K.W. Bocka and D. Schrenk (1995). "Potency of Mixtures of Polychlorinated Biphenyls as Inducers of Dioxin Receptor-regulated CYP1A Activity in Rat Hepatocytes and H4IIE Cells." Toxicology **99**: 47-54.
- Sekimoto, M., M. Iwamoto, S. Miyajima, K. Nemoto and M. Degawa (2004). "Establishment of a Rat Hepatic Cell Line, KanR2-XL8, for a Reporter Gene Assay of Aryl Hydrocarbon Receptor Ligands." Journal of Health Science **50**(5): 530-536.
- Silkworth, J. B., A. Koganti, K. Illouz, A. Possolo, M. Zhao and S.B. Hamilton (2005). "Comparison of TCDD and PCB CYP1A Induction Sensitivities in Fresh Hepatocytes from Human Donors, Sprague-Dawley Rats, and Rhesus Monkeys and HepG2 Cells." Toxicological Sciences **87**(2): 508-519.
- Suh, J., J.S. Kang, KH. Yang and N.E. Kaminski (2003). "Antagonism of Aryl Hydrocarbon Receptor-dependent Induction of CYP1A1 and Inhibition of IgM Expression by Di-ortho-substituted Polychlorinated Biphenyls." Toxicology and Applied Pharmacology **187**: 11-21.
- Tindall, J. P. (1985). "Chloracne and Chloracnegens." Journal of American Academy of Dermatology **13**(4): 539-558.
- Toyoshiba, H., N.J. Walker, A.J. Bailer and C.J. Portier (2004). "Evaluation of Toxic Equivalency Factors for Induction of Cytochromes P450 CYP1A1 and CYP1A2 Enzyme Activity by Dioxin-like Compounds." Toxicology and Applied Pharmacology **194**: 156-168.

- Urban, J. D., W.P. Clarke, M. von Zastrow, D.E. Nichols, B. Kobilka, H. Weinstein, J.A. Javitch, B.L. Roth, A. Christopoulos, P.M. Sexton, K.J. Miller, M. Spedding and R.B. Mailman (2007). "Functional Selectivity and Classical Concepts of Quantitative Pharmacology." The Journal of Pharmacology and Experimental Therapeutics **320**: 1-13.
- Van den Berg, M., B.L.H.J. Craane, T. Sinnige, S. Van Mourik, S. Dirksen, T. Boudewijn, M. van der Gaag, I.J. Lutke-Schipholt, B. Spenklink and A. Brouwer (1994). "Biochemical And Toxic Effects Of Polychlorinated Biphenyls (PCBs), Dibenzo-*p*-Dioxins (PCDDs) And Dibenzofurans (PCDFs) In The Cormorant (*Phalacrocorax Carbo*) After In Ovo Exposure." Environmental Toxicology and Chemistry **13**(5): 803-816.
- Van den Berg, M., J. De Jongh, H. Poiger and J.R. Olson (1994). "The Toxicokinetics and Metabolism of Polychlorinated Dibenzo-*p*-Dioxins (PCDDs) and Dibenzofurans (PCDFs) and Their Relevance for Toxicity " Critical Reviews in Toxicology **24**(1): 1-74.
- Van den Berg, M., L. S. Birnbaum, M. Denison, M. De Vito, W. Farland, M. Feeley, H. Fiedler, H. Hakansson, A. Hanberg, L. Haws, M. Rose, S. Safe, D. Schrenk, C. Tohyama, A. Tritscher, J. Tuomisto, M. Tysklind, N. Walker and R. E. Peterson (2006). "The 2005 World Health Organization Reevaluation of Human and Mammalian Toxic Equivalency Factors for Dioxins and Dioxin-Like Compounds." Toxicological Sciences **93**(2): 223-241.
- Vanden Heuvel, J. P., G.C. Clark, M.C. Kohn, A.M. Tritscher, W.E. Greenlee, G.W. Lucier and D.A. Bell (1994). "Dioxin-responsive Genes: Examination of Dose-Response Relationships Using Quantitative Reverse Transcriptase-Polymerase Chain Reaction." Cancer Research **54**: 62-68.
- Walker, M. K., P.M. Cook, B.C. Butterworth, E.W. Zabel and R.E. Peterson (1996). "Potency of a Complex Mixture of Polychlorinated Dibenzo-*p* dioxin, Dibenzofuran, and Biphenyl Congeners Compared to 2,3,7,8-Tetrachlorodibenzo-*p*-dioxin in Causing Fish Early Life Stage Mortality." Fundamental and Applied Toxicology **30**: 178-186.
- Walker, N. J., P.W. Crockett, A. Nyska, A.E. Brix, M.P. Jokinen, D.M. Sells, J.R. Hailey, M. Easterling, J.K. Haseman, M. Yin, M.E. Wyde, J.R. Bucher and C.J. Portier (2005). "Dose-Additive Carcinogenicity of a Defined Mixture of "Dioxin-like Compounds"." Environmental Health Perspectives **113**: 43-48.
- Whitlock, J. P. J. (1993). "Mechanistic Aspects of Dioxin Action." Chemical Research in Toxicology **6**: 754-763.
- Whitlock, J. P. J. (1999). "Induction of Cytochrome P4501A1." Annual Review of Pharmacological Toxicology **39**: 103-125.

- Whyte, J. J., C.J. Schmitt and D.E. Tillitt (2004). "The H4IIE Cell Bioassay as an Indicator of Dioxin-like Chemicals in Wildlife and the Environment." Critical Reviews in Toxicology **34**(1): 1-83.
- Wood, A. W., R.L. Chang, W. Levin, P.E. Thomas, D. Ryan, T.A. Stoming, D.R. Thakker, D.M. Jerina and A.H. Conney (1978). "Metabolic Activation of 3-Methylcholanthrene and Its Metabolites to Products Mutagenic to Bacterial and Mammalian Cells." Cancer Research **38**: 3398-3404.
- Wu, L. and J. P. Whitlock, Jr (1993). "Mechanism of Dioxin Action: Receptor - enhancer Interactions in Intact Cells." Nucleic Acids Research **21**(1): 119-125.
- Xu, M., G.B. Nelson, J.E. Moore, T.P. McCoy, J. Dai, R.A. Manderville, J.A. Ross and M.S. Miller (2005). "Induction of CYP1A1 and CYP1B1 and Formation of DNA Adducts in C57BL/6, Balb/c, and F1 Mice Following in Utero Exposure to 3-Methylcholanthrene." Toxicology and Applied Pharmacology **209**: 28-38.
- Zhang, S., C. Qin and S.H. Safe (2003). "Flavonoids as Aryl Hydrocarbon Receptor Agonists/Antagonists: Effects of Structure and Cell Context." Environmental Health Perspectives **111**: 1877-1882.