



The University of  
**Nottingham**

UNITED KINGDOM · CHINA · MALAYSIA

Adenle, Ademola A. (2010) Genetic analysis of latrophilin in the toxicity of combined latrotoxins for *C. elegans*. PhD thesis, University of Nottingham.

**Access from the University of Nottingham repository:**

<http://eprints.nottingham.ac.uk/11000/1/AdemolaAdenleThesisAugust17.pdf>

**Copyright and reuse:**

The Nottingham ePrints service makes this work by researchers of the University of Nottingham available open access under the following conditions.

This article is made available under the University of Nottingham End User licence and may be reused according to the conditions of the licence. For more details see:  
[http://eprints.nottingham.ac.uk/end\\_user\\_agreement.pdf](http://eprints.nottingham.ac.uk/end_user_agreement.pdf)

**A note on versions:**

The version presented here may differ from the published version or from the version of record. If you wish to cite this item you are advised to consult the publisher's version. Please see the repository url above for details on accessing the published version and note that access may require a subscription.

For more information, please contact [eprints@nottingham.ac.uk](mailto:eprints@nottingham.ac.uk)

**Genetic Analysis of Latrophilin**  
**in the Toxicity of Combined Latrotoxins for *C. elegans***

by

*Ademola A. Adenle, B.Sc., M.Sc*

*Being a thesis presented in accordance with the regulations governing the award of the degree  
of Doctor of Philosophy at the University of Nottingham*

August 2008

## Abstract

Black widow spider venom (BWSV) contains high molecular weight proteins called latrotoxins (LTX) that induce catastrophic neurotransmitter release from nerve terminals, and one toxin,  $\alpha$ -latrotoxin, is known to bind with high affinity to three neural proteins in mammals, including latrophilin (lat-1) a member of the class B family of G-protein coupled receptors.

We have established *C.elegans* as a model organism to study the function of the binding protein, lat-1 and its role in regulating neurotransmitter release by latrotoxins. However, a lat-1-knock-out worm is required for determining the function of the lat-1 gene. The lat-1(ok1465) allele has a deletion of the lat-1 gene, and ~95-98% of lat-1(ok1465) homozygous worms arrest or die before adulthood, with only ~2-5 adult offspring per animal. Micro-injection of the B0457 cosmid, that contains the full sequence of the lat-1 gene, or the lat-1a cDNA rescued the lethality of the lat-1 worms, thereby showing that lat-1 gene is responsible for the developmental lethality in these worms. Expression of the marker, GFP, under the control of the lat-1 promoter showed that there was expression of GFP during epithelial morphogenesis, and strong expression in the gut from the three-fold stage through to larval stages. The concordance between the site of expression of *lat-1::gfp*, with the sites of embryonic defects (epithelial enclosure defects; defective attachment of gut) in lat-1(ok1465) animals, provides further evidence that lat-1 is essential for embryonic and larval development.

Deletion mutants of lat-1a were constructed to examine the role of domains of this protein. Deletion of sequences after the 4xCys domain of lat-1a did not affect the ability to rescue lethality in the lat-1 worm, while deletion of the C-terminus to the seven transmembrane domain impaired the ability of lat-1a to rescue lat-1 worms, and further deletion of six of seven transmembrane domains (the TM1 construct) yielded a construct that was unable to rescue lat-1 worms.

These data suggest an important role for intracellular sequences and seven transmembrane in lat-1a signalling. It was proposed that TM1 could decoy ligand, without causing intracellular signalling. In agreement, the TM1 construct caused a mild phenocopy of the lat-1(ok1465) mutant in wild-type worms, whereas full-length, or non-ligand binding variants of lat-1a caused no such effect. To investigate the putative ligand-binding domain of lat-1a, deletion of residues 62-147 ( $\Delta$ GBL), 62-250 ( $\Delta$ HRM) and 62-487 ( $\Delta$ N) was investigated; while the  $\Delta$ N construct was incapable of rescuing lat-1(ok1465) worms, deletion of  $\Delta$ GBL had a minor effect on the ability of lat-1 to rescue the null worms, while  $\Delta$ HRM had a more marked effect. These data are consistent with a model whereby residues 147-487 are required for ligand binding, and the seven-transmembrane and intracellular domains transmit a signal to the inside of the cell.

Combined latrotoxins was highly toxic to wild-type *C.elegans* ( $LD_{50} \sim 4\text{ng/ml}$ ), whereas the lat-1 worms were highly ( $>10^5$ -fold) resistant to combined latrotoxins. Lat-1 worms that were transgenic for B0457cosmid, or lat-1a cDNA, were as sensitive to combined latrotoxins as wild-type worm. Truncation of the C-terminus of lat-1a to TM1 yielded worms that had  $10^5$ -fold resistance to combined latrotoxins, compared to wild-type; thus the intracellular domain of lat-1 is required for mediating combined latrotoxins toxicity. The deletion of galactose-binding lectin ( $\Delta$ GBL) in N-terminus lat-1a was sensitive as wild-type, but deletion of hormone receptor motif ( $\Delta$ HRM) in N-terminus lat-1a showed a reduced sensitivity to combined latrotoxins by  $\sim 10^5$ -fold. These data showed presence of lat-1 gene was responsible for the rescue of lat-1 worms or toxicity of combined latrotoxins in lat-1 worms, and the absence of lat-1 gene was responsible for the lethality of lat-1 worms and resistance to combined latrotoxins in lat-1 worms.

## Acknowledgement

I acknowledge the presence of God who created me and gave me this rare privilege to achieve my dream of attaining the highest qualification. It is unfortunate I will not be celebrating my accomplished success with my parents who passed away while I was studying, only God knows why he took both of you at that crucial moment of my life. I am blessed to have you as my beloved parents, rest in peace mum and dad.

I am highly indebted to my supervisor Dr David Bell who taught and supervised me during those three years of unraveling mystery behind science. It is a great honour to work with you, without a minute of doubt, you are a special teacher who is thorough in his teaching and supervision. I would like to thank Dr Julie Ahringer at Cambridge University who allowed me to train in her lab for micro-injection and also for providing tips for successful *C.elegans* transformation. ..you saved my life!!! a quote from you during a chat at *C.elegans* International Meeting, Los Angeles, USA July 2007. Although, Dr Morris Maduro (University of Riverside, California) is several thousands of miles away from me, but his patience to explain how successful micro-injection can be consistently carried out is highly appreciated.

I must thank, our technician Declan Brady for his adequate technical support in the lab, he never succumbs to pressure, even when many students would like him to attend to them at the same time. It is a pleasure to work with every member and former members of David Bell's group, the ones that assisted in the lab and the ones that made me laugh !!!

I express my deep gratitude to every member of Adenle's family (Prince Adeyera, Mr Adediran, Ms Aderonke, Mr Olalekan, Mr Adewole), all of you were very supportive during the times of my PhD. I am grateful to all my friends who cheered me throughout the hard times. I hope peo-

ple that are unnamed will not mistake it for the lack of importance or appreciation for their contributions towards successful completion of my PhD

## **Dedication**

I dedicate this thesis to the memory of my parents.

*Princess Elizabeth Mosunmola Adenle (Mother)*

and

*Chief Gabriel Amusan Adenle (Father)*

This is for everyone, not part of my thesis but part of what keeps me going as a living being!!!

It goes by, for everyone who is hardworking will reap the fruits of his labour. Difficult times never meant the end of the world, but a way to understand the essence of our beings and seek knowledge to overcome the difficult times.

A man with a dream is the one who remains determined to achieve uncommon goals and unprecedented success. I am sorry for those who don't believe in God, from my own understanding, God is the author of science that designed every living thing to flourish and gave humans the super power to rule, dominate and explore the beauty of world with a view to representing his majesty on earth, but unfortunately humans have gone astray to fulfil his purpose.

Tough times never last, tough people do (Dr Robert H. Schuller)...I am a product of tough times, ready to inconvenience myself in the pursuit of excellence to create most remarkable and uncommon life that I ever imagine.

I have just begun!!! I pray for God's guidance to reach the destination of my greatest achievement (Amen).



## Abbreviations

A	Adenine
Amp	Ampicillin antibiotic
BWSV	Black Widow Spider Venom
BSA	Bovine Serum Albumin
bp	Base pair
C	Cytosine
cDNA	Complementary Deoxyribonucleic acid
DAPI	4',6-diamidino-2-phenylindole
DNA	Deoxyribonucleic acid
EDTA	Ethylene diamine tetra acetic acid
EtBr	Ethidium Bromide
G	Guanine

IPTG            Isopropyl- $\beta$ -D-thiogalactopyranoside

K                Kanamycin Antibiotic

kb              Kilobase

kDa             KiloDalton

lat-1            latrophilin

LB              Luria-Bertani (Medium)

LCT             Latrocrustatoxin

LDS             Lithium Duodecyl Sulphate

LIT              Latroinsectotoxin

LPH             Latrophilin

LTX             Latrotoxin

NGM            Nematode Growth Medium

PAGE            Polyacrylamide Gel Electrophoresis

PCR	Polymerase Chain Reaction
RNA	Ribonucleic acids
RNAi	RNA Interference
SAP	Shrimp Alkaline Phosphatase
SDS	Sodium Dodecyl Sulphate
SEC	Size Exclusion Column
T	Thymine
TAE	Tris/Glacial acetic acid /EDTA
TBE	Tris/Boric acid/EDTA
TBS	Tris Buffered Saline
TEMED	N,N,N',N'-tetramethylethylenediamine
X-gal	5-bromo-4-chloro-3-indolyl-b-D-galactopyranoside
UHP	Ultra High Purity

---

**TABLE OF CONTENTS**

Abstract .....	2
Acknowledgement .....	4
Dedication .....	6
Abbreviations .....	8
1 Introduction .....	17
1.1 Latrophilin .....	17
1.1.1 Latrophilin /calcium-independent receptor for $\alpha$ -latrotoxin (CIRL) .....	17
1.1.1.1 Mechanism of action and binding of latrophilin to $\alpha$ -latrotoxin .....	19
1.1.2 Neurexin as $\alpha$ -latrotoxin receptor .....	21
1.1.3 Protein tyrosine phosphatase $\sigma$ is an $\alpha$ -latrotoxin receptor .....	23
1.2 Black widow spider venom (BWSV) .....	24
1.2.1 History of Black Widow Spider Venom .....	24
1.2.2 Toxin of the Black Widow Spider Venom .....	26
1.2.2.1 $\alpha$ -Latrotoxin .....	26
1.2.2.1.1 Dimer and Tetramer formation of $\alpha$ -LTX .....	29
1.2.2.2 Crustacean-specific neurotoxin ( $\alpha$ -LCT) .....	31
1.2.2.3 Insect-specific neurotoxin ( $\alpha$ -LIT) .....	31
1.3 <i>Caenorhabditis elegans</i> .....	32
1.3.1 The experimental model organism <i>C.elegans</i> .....	32
1.3.1.1 Sex and Chromosome .....	33
1.3.1.2 Life Cycle .....	34
1.3.1.3 Defecation cycle and feeding .....	35
1.3.2 The nervous system of <i>C.elegans</i> .....	36
1.3.3 Synaptic function .....	37
1.3.4 Latrophilin the <i>C.elegans</i> homologue .....	39
1.4 Summary .....	40
1.5 Objectives of this Research Project .....	41
1.5.1 Where is lat-1 expressed? .....	41
1.5.2 What is the phenotype of the lat-1 null worm ? .....	41
1.5.3 What is the role of latrophilin in BWSV toxicity ? .....	41
2 Materials and Methods .....	42
2.1 Materials .....	42
2.2 Methods .....	43
2.3 Molecular biology technique .....	43
2.3.1 <i>E.coli</i> Cultures .....	43
2.3.2 <i>E.coli</i> calcium competent preparation .....	43
2.3.3 Transformation of calcium competent <i>E.coli</i> .....	43
2.3.4 <i>E.coli</i> electro-competent preparation .....	44
2.3.5 Transformation of <i>E.coli</i> electro-competent .....	44
2.4 DNA Extraction and Purification .....	44
2.4.1 Phenol-Chloroform extraction of DNA .....	44
2.4.2 Ethanol precipitation of DNA .....	45
2.4.3 Alkaline lysis method of DNA preparation .....	45
2.4.4 Preparation of DNA using Qiagen mini-prep column .....	46
2.4.5 Preparation of DNA using Qiagen-tip 500 maxi-prep column .....	47
2.4.6 Preparation of Cosmid DNA .....	47
2.4.7 Restriction enzyme digest of plasmid DNA .....	48
2.4.8 DNA agarose gel electrophoresis .....	48

---

---

2.4.9 DNA purification using QIAEX II gel extraction kit	49
2.4.10 <i>C.elegans</i> genomic DNA extraction	49
2.4.11 Purification of DNA using Wizard DNA Clean-up system	50
2.4.12 DNA treatment using alkaline phosphatase	50
2.4.13 Ligation of DNA	51
2.5 Polymerase chain reaction (PCR)	51
2.5.1 Purification of PCR products	52
2.6 <i>C.elegans</i> Methods	53
2.6.1 Growth and Maintenance of <i>C.elegans</i>	53
2.6.2 Culturing of <i>C.elegans</i>	54
2.6.3 Worm Harvesting	54
2.6.4 Removal of contamination and egg isolation of <i>C.elegans</i>	55
2.6.5 Synchronization of worms	55
2.6.6 Freezing of worms	56
2.6.7 Imaging	56
2.6.8 Mounting worms for imaging	57
2.7 Transformation of <i>C.elegans</i>	57
2.7.1 Micro-injection of Dextran into <i>C.elegans</i>	58
2.7.2 Micro-injection of DNA into <i>C.elegans</i>	58
2.7.2.1 Agarose pad preparation	59
2.7.2.2 Mounting of worms on agar pad	59
2.7.2.3 Preparation of Micro-injection needle	60
2.7.2.4 Loading of DNA solution into the needle	61
2.7.2.5 Mounting and breaking of the needle	61
2.7.2.6 Micro-injection technique and worm recovery	62
2.7.3 Micro-injection of Black Widow Spider Venom (Combined latrotoxins)	63
2.7.4 Integration of transgene array in <i>C.elegans</i>	63
2.7.5 Staining <i>C.elegans</i> for $\beta$ -galactosidase expression	64
2.8 Developmental and Behavioural assay in <i>C.elegans</i>	65
2.8.1 Embryonic culture	65
2.8.2 Larval culture	65
2.8.3 Measurement of brood size	65
2.8.4 Defecation cycle	66
2.8.5 Touch sensitivity	66
2.9 Protein methodologies	66
2.9.1 Preparation of combined latrotoxin protein	66
2.9.2 Bradford protein assay (Coomassie blue)	67
2.9.3 Lithium duodecyl sulphate-polyacrylamide gel electrophoresis (LDS-PAGE)	67
2.9.4 Coomassie blue gel staining	68
2.10 Experimental design of Plasmids	68
2.10.1 Construction of 5' end of <i>lat-1</i> promoter	69
2.10.1.1 Creation of <i>lat-1::lacZ</i> constructs	69
2.10.1.2 Creation of <i>lat-1::GFP</i> construct	71
2.10.2 Construction of plasmids for the rescue of <i>lat-1(ok1465)</i> worms	71
2.10.2.1 Creation of full-length <i>lat-1a</i> cDNA construct	72
2.10.2.2 Creation of C-terminal <i>lat-1a</i> cDNA construct	73
2.10.2.3 Creation of N-terminal <i>lat-1a</i> cDNA construct	76
2.10.3 Construction of <i>aex-3</i> plasmid	78
2.10.4 Construction of selectable markers	79

---

---

2.10.5 Statistical analysis	80
2.10.6 Worm strains	80
3 Results	82
3.1 Optimisation of Microinjection	82
3.1.1 Injection of Rhodamine-Dextran into <i>C.elegans</i>	82
3.1.2 Effect of DNA Concentration on Transformation of <i>C.elegans</i>	83
3.2 Structure of lat-1 ok1465 allele	85
3.2.1 Deletion of lat-1 allele	85
3.2.2 Phenotype of lat-1 ok1465 allele	87
3.3 Expression pattern under the lat-1 gene promoter	90
3.3.1 Generation of lat-1::LacZ transgenic animals	90
3.3.2 Generation of lat-1::GFP transgenic animals	92
3.3.2.1 Integration of extrachromosomal arrays by $\gamma$ -irradiation	94
3.3.2.2 Characterisation of reporter gene expression	95
3.3.2.2.1 Expression pattern of lat-1::GFP or lat-1::LacZ during embryonic development	95
3.3.2.2.2 Post embryonic expression of lat-1 gene promoter	97
3.4 Effect of B0457 cosmid	101
3.4.1 B0457 cosmid rescues the lat-1 (ok1465) allele	101
3.4.1.1 Stability of unc-54::cfp transgene on lat-1 (ok1465) worms	103
3.4.2 Phenotypic effect of B0457 cosmid and CFP on lat-1 (ok1465) worms	105
3.4.2.1 Effect of B0457 on developmental lethality in lat-1(ok1465)	106
3.4.2.2 Effect of B0457 on defecation cycle in lat-1(ok1465) worms	106
3.5 Analysis of lat-1 gene	108
3.5.1 Full-length lat-1a cDNA rescued the lat-1(ok1465) worms	108
3.5.1.1 Stability of mCherry transgene of lat-1a cDNA on lat-1(ok1465) worms	110
3.5.1.2 Phenotypic effect of lat-1a cDNA and mCherry on lat-1 (ok1465) worms	111
3.5.1.2.1 Effect of lat-1a cDNA on developmental lethality	111
3.5.1.2.2 Effect of full-length lat-1a cDNA on defecation cycle	112
3.5.2 Identification of functional domains of lat-1a	112
3.5.2.1 Role of the lat-1a C-terminus	113
3.5.2.1.1 Stability of mCherry transgene in transgenic lat-1 (ok1465) worms	116
3.5.2.1.2 Effect of C-terminally truncated lat-1a in lat-1(ok1465) worms	116
3.5.2.2 Role of the lat-1a N-terminus	118
3.5.2.3 Stability of mCherry transgene in transgenic worms	120
3.5.2.4 Effect of N-terminal deletions in lat-1 (ok1465) worms	121
3.5.2.4.1 Effect on developmental lethality of lat-1 (ok1465) worms	121
3.5.2.5 Effect of N-terminal truncations on defecation cycle	122
3.6 Is TM1 a dominant negative?	123
3.6.1 Transmission of mCherry transgene	125
3.6.2 Phenotypic effects of TM1 on wild-type worms	126
3.6.2.1 Developmental effect of TM1	126
3.6.2.2 Effect of TM1 lat-1a cDNA on defecation cycle in wild-type worms	127
3.7 Tissue-specific expression of lat-1a	129
3.7.1 aex-3 promoter driving lat-1a expression	129
3.7.2 Effect of aex-3 reporter construct on wild-type worms	131
3.7.3 Stability of mCherry transgene of aex-3 reporter construct on wild-type	132
3.7.4 Phenotypic effect of aex-3 reporter construct and mCherry on wild-type	133
3.7.4.1 Effect of aex-3 construct on development	133
3.7.4.2 Effect of aex-3 reporter construct on defecation cycle	133

---

---

<b>3.8</b>	<b>The action of Black Widow Spider Venom</b>	<b>134</b>
<b>3.8.1</b>	<b>Partial purification of toxins from combined latrotoxins</b>	<b>134</b>
<b>3.8.2</b>	<b>Effect of combined latrotoxins on <i>C.elegans</i></b>	<b>136</b>
<b>3.8.2.1</b>	<b>Effect of combined latrotoxins on wild-type worms and lat-1(ok1465) worms</b>	<b>136</b>
<b>3.8.2.2</b>	<b>The lat-1 gene confers sensitivity to combined latrotoxins in lat-1(ok1465) worms</b>	<b>137</b>
<b>3.8.2.3</b>	<b>Defining regions of lat-1a required for combined latrotoxins toxicity</b>	<b>139</b>
<b>3.8.2.3.1</b>	<b>C-terminal deletions of lat-1a</b>	<b>140</b>
<b>3.8.2.3.2</b>	<b>N-terminal deletions of lat-1a</b>	<b>141</b>
<b>3.8.3</b>	<b>Dose-effect curve of potassium cyanide (KCN) on transgenic worms, lat-1(ok1465) worms and wild-type worms</b>	<b>142</b>
<b>4</b>	<b>Discussion</b>	<b>145</b>
<b>4.1</b>	<b>Optimisation of transgenesis</b>	<b>145</b>
<b>4.2</b>	<b>The phenotype of lat-1 allele</b>	<b>145</b>
<b>4.3</b>	<b>Expression of lat-1 reporter gene</b>	<b>146</b>
<b>4.3.1</b>	<b>Expression of lat-1 gene and physiological relevance</b>	<b>147</b>
<b>4.3.2</b>	<b>Characterisation of rescue of lat-1 (ok1465) worm phenotype</b>	<b>149</b>
<b>4.4</b>	<b>The role of lat-1 gene in <i>C.elegans</i></b>	<b>150</b>
<b>4.4.1</b>	<b>Importance of lat-1a C-terminus</b>	<b>150</b>
<b>4.4.2</b>	<b>Importance of lat-1a N-terminus</b>	<b>151</b>
<b>4.5</b>	<b>TM1 acts as a dominant negative</b>	<b>153</b>
<b>4.6</b>	<b>aex-3 promoter for tissue-specific expression of lat-1a</b>	<b>154</b>
<b>4.7</b>	<b>Mechanism of action of combined latrotoxins in <i>C.elegans</i></b>	<b>156</b>
<b>4.7.1</b>	<b>Combined latrotoxins are sensitive to lat-1 gene in lat-1(ok1465) worm</b>	<b>156</b>
<b>4.7.2</b>	<b>The role of lat-1a C-terminus in combined latrotoxin toxicity</b>	<b>159</b>
<b>4.7.3</b>	<b>The role of lat-1a N-terminus in combined latrotoxin toxicity</b>	<b>160</b>
<b>4.7.4</b>	<b>The toxicity of Potassium cyanide (KCN)</b>	<b>161</b>
<b>4.8</b>	<b>Future work</b>	<b>161</b>
<b>4.8</b>	<b>References</b>	<b>163</b>

## LIST OF FIGURES

<b>Figure 1.1</b>	Structural domains of latrophilin/CIRL	18
<b>Figure 1.2</b>	Model of the latrophilin or neurexin binding to $\alpha$ -latrotoxin	20
<b>Figure 1.3</b>	Structural domains of neurexin	22
<b>Figure 1.4</b>	Model of structural domain of the latrotoxins	28
<b>Figure 1.5</b>	The cryo-EM reconstruction and model system of $\alpha$ -LTX tetramer	30
<b>Figure 1.6</b>	Schematic diagram of two sexes of <i>C.elegans</i> , adapted from Wood 1988	33
<b>Figure 1.7</b>	The timing of development and life cycle of <i>C.elegans</i>	34
<b>Figure 2.1</b>	The Syncytial gonad of <i>C.elegans</i>	58
<b>Figure 2.2</b>	Demonstration of micro-injection of DNA into the <i>C.elegans</i>	62
<b>Figure 2.3</b>	The map of <i>lat-1::lacZ</i> constructs	70
<b>Figure 2.4</b>	The map of <i>lat-1::GFP</i> construct	71
<b>Figure 2.5</b>	The map of full-length <i>lat-1</i> cDNA	73
<b>Figure 2.6</b>	The map of C-terminal <i>lat-1</i> cDNA	75
<b>Figure 2.7</b>	The map of N-terminal <i>lat-1</i> cDNA	77
<b>Figure 2.8</b>	The map of <i>aex-3</i> plasmid	79
<b>Figure 2.9</b>	The map of <i>unc-54::mcherry</i> plasmid	80
<b>Figure 3.1</b>	Injection of rhodamine dextran into adult hermaphrodite.	82
<b>Figure 3.2</b>	The ok1465 <i>lat-1</i> allele	86
<b>Figure 3.3</b>	Phenotypes of <i>lat-1(ok1465)</i> worms and wild-type (N2 Bristol).	89
<b>Figure 3.4</b>	Transcriptional fusions of <i>lat-1</i> gene promoter to <i>lacZ-gfp</i>	91
<b>Figure 3.5</b>	Transcriptional <i>gfp</i> fusion with the <i>lat-1</i> gene promoter	93
<b>Figure 3.6</b>	Embryonic expression pattern of <i>lat-1::GFP</i>	96
<b>Figure 3.7</b>	Expression pattern of <i>lat-1::LacZ</i> in wild-type	99
<b>Figure 3.8</b>	Expression pattern of <i>lat-1::GFP</i> in wild-type	100
<b>Figure 3.9</b>	Segregation of (B0457; <i>unc-54::cfp</i> ) transgene	104
<b>Figure 3.10</b>	Expression construct for full-length <i>lat-1a</i> cDNA	108
<b>Figure 3.11</b>	Cartoon depicting C-terminal deletions of <i>lat-1a</i>	113
<b>Figure 3.12</b>	Cartoon depicting deletion of N-terminal <i>lat-1a</i> cDNA	118
<b>Figure 3.13</b>	Phenotypes of TM1 <i>lat-1a</i> cDNA on wild-type worms	128
<b>Figure 3.14</b>	Translational reporter gene fusion of <i>lat-1a</i> cDNA driven by <i>aex-3</i> promoter	129
<b>Figure 3.15</b>	Purification of combined latrotoxins protein	135
<b>Figure 3.16</b>	A dose curve effect of combined latrotoxins on wild-type and <i>lat-1</i> worms	137
<b>Figure 3.17</b>	A dose curve-effect of combined latrotoxins on full-length <i>lat-1a</i> or B0457 cosmid worms	139
<b>Figure 3.18</b>	Dose-response of combined latrotoxins on C-terminally-truncated <i>lat-1a</i> worms	141
<b>Figure 3.19</b>	Dose-response of combined latrotoxins on N-terminally truncated <i>lat-1a</i> worms	142
<b>Figure 3.20</b>	A dose curve-effect of KCN on <i>C.elegans</i>	143
<b>Figure 4.1</b>	TM1 decoying pathway	154
<b>Figure 4.2</b>	Effect of latrophilin in <i>C.elegans lat-1 (ok1465)</i> worms and mammals	158



---

**LIST OF TABLES**

<b>Table 1.1</b> The grading scale for envenomations of <i>Latrodectus</i> Black Widow Spider . . .	<b>25</b>
<b>Table 2.1</b> X-gal staining solution . . . . .	<b>64</b>
<b>Table 2.2</b> Oligonucleotides of <i>lat-1::lacZ</i> constructs . . . . .	<b>69</b>
<b>Table 2.3</b> Oligonucleotides of full-length <i>lat-1</i> lacDNA construct . . . . .	<b>72</b>
<b>Table 2.4</b> Oligonucleotides of C-terminal <i>lat-1a</i> cDNA construct . . . . .	<b>74</b>
<b>Table 2.5</b> Oligonucleotides of N-terminal <i>lat-1a</i> cDNA construct . . . . .	<b>76</b>
<b>Table 2.6</b> Oligonucleotides of <i>aex-3</i> constructs . . . . .	<b>78</b>
<b>Table 2.7</b> Oligonucleotides of selectable marker <i>unc-54::mcherry</i> . . . . .	<b>80</b>
<b>Table 2.8</b> List of transgenic strains . . . . .	<b>81</b>
<b>Table 3.1</b> Effect of DNA concentration on transgenesis . . . . .	<b>84</b>
<b>Table 3.2</b> Measurement of offspring survival . . . . .	<b>87</b>
<b>Table 3.3</b> Characterisation of <i>lat-1</i> reporter and pRF4 <i>transgenesis</i> . . . . .	<b>92</b>
<b>Table 3.4</b> Characterisation of <i>lat-1</i> reporter and <i>unc-54::mCherry</i> . . . . .	<b>93</b>
<b>Table 3.5</b> Integration of <i>LacZ</i> reporter transgenes . . . . .	<b>94</b>
<b>Table 3.6</b> Integration of GFP reporter transgenes . . . . .	<b>95</b>
<b>Table 3.7</b> Effect of B0457 Cosmid and <i>unc-54::cfp</i> DNA on <i>lat-1</i> (ok1465) worms . . . . .	<b>102</b>
<b>Table 3.8</b> The <i>unc-54::cfp</i> transgene stability . . . . .	<b>103</b>
<b>Table 3.9</b> The B0457 cosmid rescues <i>lat-1</i> (ok1465) phenotypes . . . . .	<b>107</b>
<b>Table 3.10</b> Effect of full-length <i>lat-1a</i> cDNA and mCherry DNA on <i>lat-1</i> (ok1465) worms . . . . .	<b>109</b>
<b>Table 3.11</b> The mCherry transgene stability of <i>lat-1a</i> cDNA . . . . .	<b>110</b>
<b>Table 3.12</b> Effect of <i>lat-1a</i> cDNA on <i>lat-1</i> (ok1465) lethality . . . . .	<b>111</b>
<b>Table 3.13</b> Effect of C-terminal <i>lat-1a</i> cDNA and m-Cherry DNA on <i>lat-1</i> (ok1465) worms . . . . .	<b>114</b>
<b>Table 3.14</b> The mCherry transgene of C-terminal <i>lat-1a</i> cDNA stability . . . . .	<b>115</b>
<b>Table 3.15</b> Effect of C-terminal <i>lat-1</i> gene on <i>lat-1</i> (ok1465) phenotypes . . . . .	<b>116</b>
<b>Table 3.16</b> Effect of N-terminal <i>lat-1</i> gene and <i>mCherry</i> DNA on <i>lat-1</i> (ok1465) worms . . . . .	<b>120</b>
<b>Table 3.17</b> The mCherry transgene of N-terminal <i>lat-1a</i> cDNA stability . . . . .	<b>121</b>
<b>Table 3.18</b> Effect of N-terminal <i>lat-1a</i> cDNA on <i>lat-1</i> (ok1465) phenotypes . . . . .	<b>121</b>
<b>Table 3.19</b> Effect of TM1 <i>lat-1a</i> cDNA and mCherry DNA on wild-type worms . . . . .	<b>124</b>
<b>Table 3.20</b> The mCherry transgene of TM1 <i>lat-1a</i> cDNA stability . . . . .	<b>125</b>
<b>Table 3.21</b> Effect of TM1 <i>lat-1a</i> cDNA on wild-type phenotypes . . . . .	<b>127</b>
<b>Table 3.22</b> Effect of <i>aex-3</i> reporter construct and mCherry DNA on <i>lat-1</i> (ok1465) worms . . . . .	<b>130</b>
<b>Table 3.23</b> Effect of <i>aex-3</i> reporter construct and mCherry DNA on wild-type worms . . . . .	<b>131</b>
<b>Table 3.24</b> The mCherry transgene of <i>aex-3</i> reporter construct stability . . . . .	<b>132</b>
<b>Table 3.25</b> Effect of <i>aex-3</i> construct on wild-type worm phenotypes . . . . .	<b>133</b>

# Chapter 1 Introduction

## Section 1.1 Latrophilin

### Section 1.1.1 Latrophilin /calcium-independent receptor for $\alpha$ -latrotoxin (CIRL)

Latrophilin/CIRL is a seven-transmembrane protein that belongs to the secretin/calcitonin family of G-coupled receptors. It was originally isolated from bovine brain membranes by affinity chromatography as a glycosylated protein 120kDa [6], [7]. It is found mostly in neuronal or neuroendocrine tissues [6], and is the major protein to bind to immobilized  $\alpha$ -latrotoxin, a component of Black Widow Spider Venom (BWSV), in the absence of divalent cations [8]. Latrophilin has a long glycosylated extracellular domain, a transmembrane domain with seven-transmembrane segments, and a large cytoplasmic tail. The seven-transmembrane domain shows high similarity to other members of the secretin/calcitonin sub-family of the GPCR superfamily which induce the release of different substances caused by peptide hormone binding [9]. The extracellular sequence has several identifiable domains, such as; I) the signal peptide; II) a lectin-like sequence (~92 residues); III) the surface attachment of olfactomedin matrix protein and myocilin, a longer domain (~290 residues) [8] [130]; IV) a long domain (~280 residues) which is homologous to BAI 1, 2, and 3 (brain-specific angio-genesis inhibitors) with unknown functions [11]; V) a short, cysteine-rich sequence (90 residues) which is located just after N-terminal of first transmembrane domain [1]. However, the hormone receptor motif domain (HRM) has been found in G-protein coupled receptors which is presumably involved in ligand binding and stalk domain that is essential for proteolytic cleavage [12] and G-protein coupled receptor proteolysis.

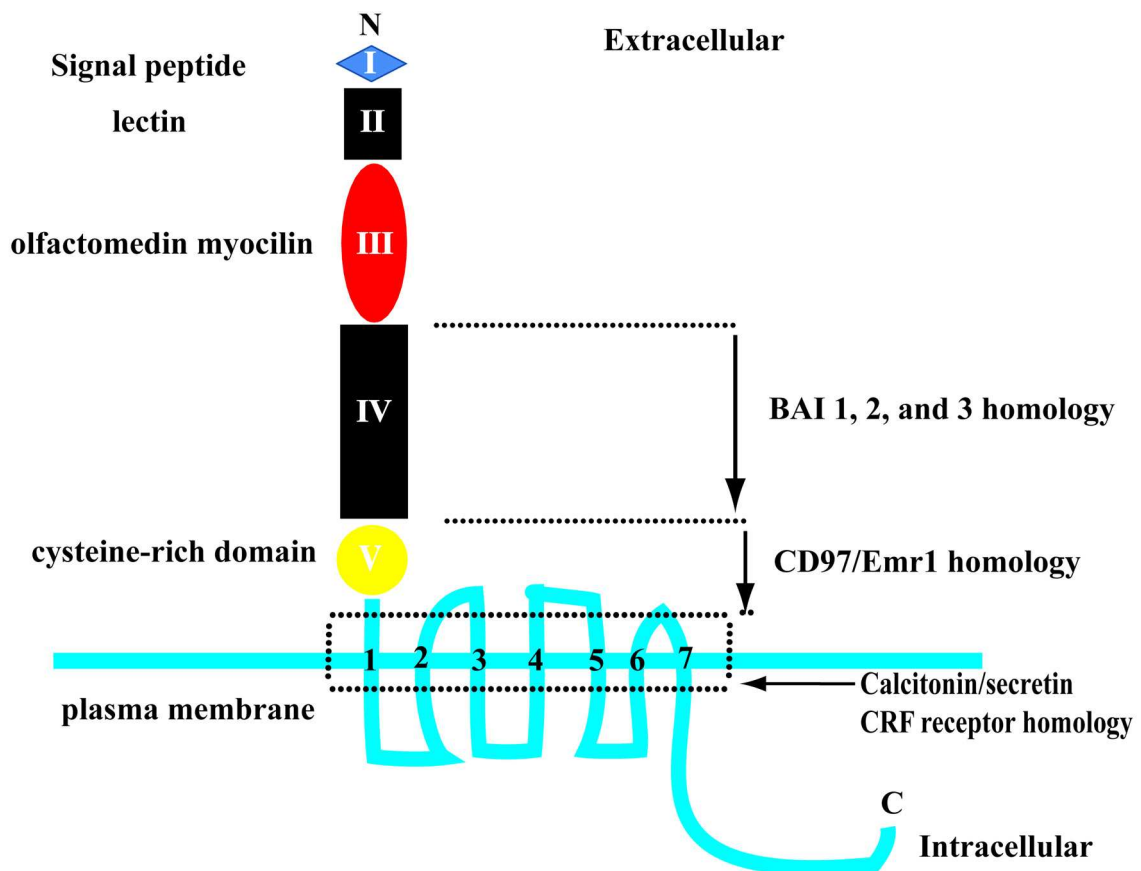

**Figure 1.1 Structural domains of latrophilin/CIRL.** The CIRL is a G-protein coupled receptor with large extracellular and intracellular domains. The extracellular domain has five structure motifs, as shown above the plasma membrane and intracellular domain without identified homologous sequences. Extracellular domains shows an N-terminal signal peptide (SP), a lectin-like domain that is homologous to olfactomedin and myocilin and a cysteine-rich domain. Also shown in extracellular domain is a short linker sequence next to long sequence (BAI 1, 2, 3) found in G-protein-coupled receptor is closely related to LPH1, 2, 3, as described in dotted lines. LPH 1, 2, 3 are also homologous to a number of G-proteins the cysteine-rich domain CD97/EMr1 as shown in dotted lines. Seven transmembrane (7TMR) are similar to calcitotropin-releasing factor (CRF) next to a long intracellular cytoplasmic tail at the C-terminal. Reproduced from [1].

It is thought that most members of latrophilin family are receptors for biologically active peptides that regulate various secretory processes [13]. Only mammalian proteins have been studied so far, out of the three isoforms of latrophilin found in mouse, rat, cow and man. LPH 1 and 2 are calcium independent when they bind to  $\alpha$ -latrotoxin. LPH 1 is the only homologue that binds  $\alpha$ -latrotoxin with high affinity, LPH 2 is expressed ubiquitously and has a 10-fold weaker affinity, LPH 3 is highly expressed in mammalian brain [1] [14] [15]. LPH 1, 2 and 3 are G-

coupled protein receptors with interesting patterns of homology (Figure 1.1). Latrophilins are unusually large, but few G- protein coupled receptors such as orphan receptors called BAI 1, 2, 3 are larger. As G-protein coupled receptors, both LPH 1, 2, 3 and BAI 1, 2, 3 share two extracellular homology domains (the BAI homology region and cysteine-rich domain) and TMRs. The overall structure of latrophilin suggests that they function to couple cell adhesion via the olfactomedin- and lectin-like domains to cell signalling [1].

#### **Section 1.1.1.1 Mechanism of action and binding of latrophilin to $\alpha$ -latrotoxin**

When latrophilin binds to  $\alpha$ -latrotoxin in the presence or absence of calcium, exocytosis is activated [7]. During the binding process to  $\alpha$ -latrotoxin, four pathways were observed; (i) binding of  $\alpha$ -latrotoxin to latrophilin as a receptor or to both latrophilin and neurexin; (ii) pore formation (conformational change) after insertion into the plasma membrane; (iii) formation of  $\text{Ca}^{2+}$  channels; (iv) intracellular signalling after activation of receptor. It has been demonstrated that another receptor neurexin triggers exocytosis through pore formation but this can only take place in the presence of calcium [16].

It was found out that  $\alpha$ -latrotoxin becomes resistant to proteases after incubation with synaptosomes, and this was proposed to be due to insertion of  $\alpha$ -latrotoxin into the plasma membrane [17]. Two distinct conformational changes were observed under different incubation temperatures, as identified by protease resistance patterns. There is a conformational change when  $\alpha$ -latrotoxin binds to receptors at 4°C that changes its protease digestion pattern without increasing protease resistance, and this was hypothesised to be receptor-induced change at the membrane. The protease resistance pattern changed dramatically with almost total protection of  $\alpha$ -latrotoxin from digestion when synaptosomes of receptor-bound  $\alpha$ -latrotoxin were heated to 37°C. The observation of protease protection was independent of the type of protease used, and is proposed to be due to partial membrane insertion of the  $\alpha$ -latrotoxin.

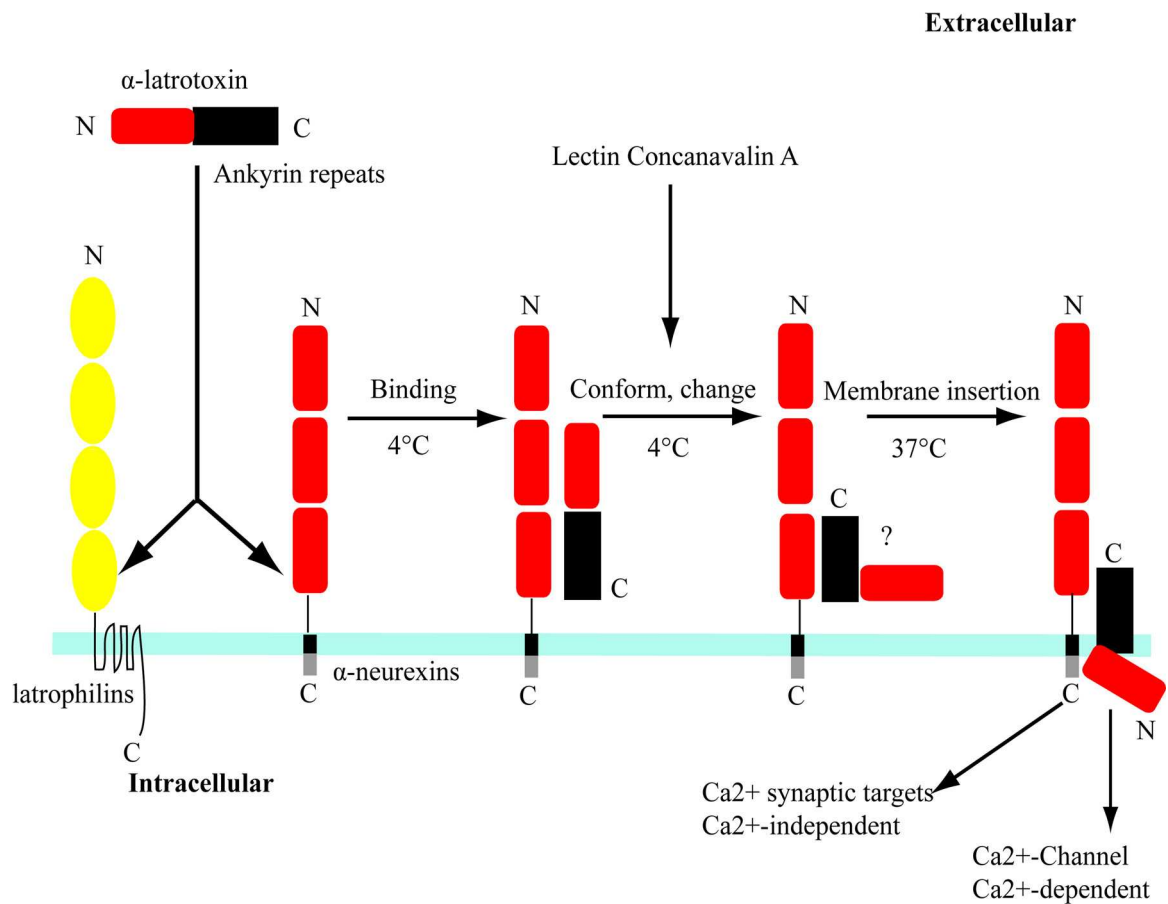

**Figure 1.2 Model of the latrophilin or neurexin binding to  $\alpha$ -latrotoxin .** Latrophilin binds to  $\alpha$ -latrotoxin or neurexin; there is then a conformational change occurs at 4°C which stimulates membrane insertion that needs higher temperature. The presence of lectin concanavalin A is involved in conformational change but does not prevent binding of receptor.  $\text{Ca}^{2+}$  channel formation and translocation into the presynaptic intracellular space occur from membrane insertion triggering two processes of exocytosis. N and C represent N-terminals and C-terminals of different proteins. Reproduced from [2].

The intracellular activation of receptor is related to the calcium dependence in the action of  $\alpha$ -latrotoxin and is also dependent on the involvement of type of neurotransmitter vesicle. During the binding process,  $\alpha$ -latrotoxin acts as a channel that conducts  $\text{Ca}^{2+}$  in the membrane and the influx of  $\text{Ca}^{2+}$  triggers a number of intracellular events. This leads to exocytosis of dense-core vesicles containing noradrenaline, dopamine and neuropeptides or alternatively action of  $\alpha$ -latrotoxin occurring in a  $\text{Ca}^{2+}$  independent manner through stimulation of exocytosis of small clear vesicles containing acetylcholine, glutamate and GABA [17]. The stimulation of exocytosis is

caused by high doses of  $\alpha$ -latrotoxin that cause depletion of acetylcholine-containing vesicles in the absence of calcium whereas neuropeptide-containing dense-core vesicles remain unchanged in the absence of calcium during different actions at neuromuscular junction. These receptors bind  $\alpha$ -latrotoxin and stimulate exocytosis through a second messenger mechanism [18], [1].

### **Section 1.1.2 Neurexin as $\alpha$ -latrotoxin receptor**

Neurexin, similar to latrophilin, can bind to  $\alpha$ -latrotoxin, but binding differs on the basis of calcium dependence. Neurexins consist of polymorphic cell surface proteins that are expressed in neurons and discovered in the process of cloning presynaptic receptor for  $\alpha$ -latrotoxin [19] [20]. Three neurexin genes (1-3) were identified in a rat brain cDNA library. Ushkaryov and co-authors (1992) have observed that each neurexin gene has two independent promoters which generate two classes of mRNAs;  $\alpha$ -neurexin is encoded in the longer mRNAs, while  $\beta$ -neurexin is encoded in the shorter mRNAs. Neurexin has six principal isoforms ( $I\alpha$ ,  $I\beta$ ,  $II\alpha$ ,  $II\beta$ ,  $III\alpha$  and  $III\beta$ ), of which neurexin  $I\alpha$  corresponds to the high molecular weight component of the  $\alpha$ -latrotoxin receptor. Neurexin- $I\alpha$  is a protein of 160-220kDa which was isolated on  $\alpha$ -latrotoxin column from solubilized bovine brain membrane using affinity chromatography [19] [20]. These neurexins differ in their N-terminal structures but share the same C-terminal sequences [20]

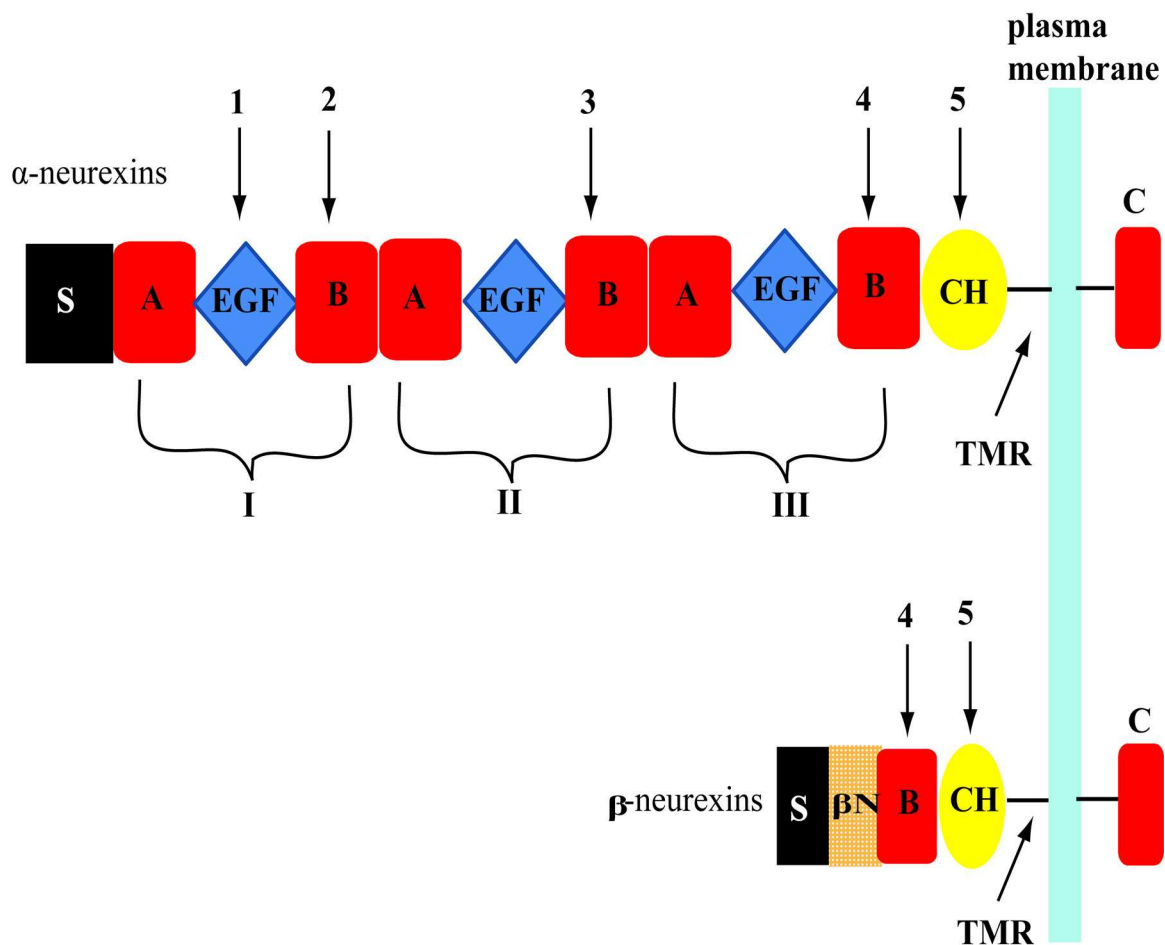

**Figure 1.3 Structural domains of neurexin.** The diagram shows the structures of  $\alpha$ -neurexin and  $\beta$ -neurexin. Three cassettes of  $\alpha$ -neurexin are represented as I, II, III. Each cassette is made up of two domains (A&B) (red) with central epidermal growth factor (EGF)-like sequence (blue) in between.  $\beta$ -neurexin does not possess most of N-terminal domains which are present in  $\alpha$ -neurexin but made up of only B domain of cassette III. Both  $\alpha$ -neurexin and  $\beta$ -neurexin have carbohydrate attachment sequence (CH) (yellow), transmembrane domain (TMR) (black arrow) and short cytoplasmic tail (C) (red). Five canonical positions are shown in black arrows (1-5) for extensive alternative splicing of  $\alpha$ -neurexin and two (4-5) canonical positions of  $\beta$ -neurexin in black arrow. Reproduced from[[ Sudhof, 2001 #35]]

As shown in Figure 1.3, neurexins contain six domains and their dominant component is the LNS domain which were named after repeated sequences Laminin A, Neuraxins, and Sex hormone-binding protein. The LNS domains are found in a large number of proteins, including serum proteins which are the components of the extracellular matrix and cell surface receptors involved in cell-cell interaction separated by EGF-like sequence [20].  $\alpha$ -Neurexins contains an

O-glycosylation sequence and a single transmembrane domain after the 3 sets of LNSA-EGF-LNSB domains which is followed by a relatively conserved short cytoplasmic tail of 55 amino acids. The genomic analysis has shown that NRXN1 gene contains 24 exons and spans 1.1Mb. Exon 1 is more than 2kb in size, and encodes the first LNS domain and the EGF-like domain [22]. It has been demonstrated that neurexin interacts with CASK, a potential intracellular signaling molecule which is a cytosolic protein with calcium-calmodulin-kinase (CaMK) domain and guanylate kinase domain, but their roles in mediating action of  $\alpha$ -latrotoxin and neurexin are yet to be investigated [23].

### **Section 1.1.3 Protein tyrosine phosphatase $\sigma$ is an $\alpha$ -latrotoxin receptor**

Protein tyrosine phosphatase  $\sigma$  (PTP  $\sigma$ ) is a member of the LAR family of receptor tyrosine phosphatases and a third receptor that binds  $\alpha$ -latrotoxin ( $\alpha$ -LTX) in brain, and is a calcium-independent binding receptor like latrophilin. [24], [25]. Petrenko and his colleagues (2002) have shown that PTP  $\sigma$  binds to  $\alpha$ -LTX through an extracellular cell adhesion-like region, with similar affinity to latrophilin and neurexin. It is known that the extracellular region containing four fibronectin type III repeats (FN3) of PTP  $\sigma$  binds to  $\alpha$ -LTX, allowing toxin insertion into the membrane. Different types of membrane phosphatase have been discovered independently in several laboratories called: PTP $\sigma$ , PTP NE-3, PTP-P1, LAR-PTP2 [26], [27]. PTP  $\sigma$  has been identified as an essential protein for neuronal development and axonal path-finding in genetic studies of mouse and *Drosophila* [28], [25]. However, a recent finding has demonstrated that spliced 3 variant of PTP  $\sigma$  can mediate the insulin-secretion triggered by  $\alpha$ -LTX [29]. Even though, PTP  $\sigma$  is important for the diverse processes such as axon development, lymphocyte activation and cell motility through signaling, the mechanisms responsible for regulation of these enzymes are yet to be fully understood [30].



## **Section 1.2 Black widow spider venom (BWSV)**

### **Section 1.2.1 History of Black Widow Spider Venom**

Spiders as predators are known to feed on insects, arthropods, small animals and are always found in the environment around human beings. Most spiders are not naturally aggressive, harmless to humans and live in close association with man [31]. About 30,000 species of spider are currently recognized worldwide and some produce venoms that could pose danger to human health [32]. Though, no true incidence of death caused by venom from spider bite has been reported due to the lack of adequate data collection of poisoning and envenomation cases in most regions. It has been reported that data collected by Poisons Information Centres in various countries indicate that a good number of calls from general public was due to spider bite. About 0.04% incidence of calls regarding spider bite has been recorded from American Association of Poison Control Centers data collection in USA. In the Asia-Pacific region, the report has shown that a number of spider toxin can produce either serious systemic clinical envenomation syndromes or significant local reactions [33].

Spider venom contains a rich cocktail of neurotoxins made up of a complex mixture of enzymes, nucleic acids, amino acids, inorganic salts, monoamines and proteinaceous and non-proteinaceous materials, and many of these bioactive compounds are lethal to humans or insects [34]. It is known that some toxins have been an important molecular tools for the identification and characterisation of ion channels that stimulate the process of neurotransmitter exocytosis. While some are under the investigation for the possibility of using them as bioinsecticidal agents for pest control.

However, Black Widow Spider is probably the most clinically significant group of spiders that belongs to the genus *Latrodectus*, and they are found on all continents apart from Antarctica. The European Black Widow spider *Latrodectus tredecimguttatus* neurotoxin has been isolated

and reported up to date. The venom of this spider has been rarely fatal but may result in incapacitating syndrome of severe local, regional, or systemic pain and autonomic features referred to as *Latrodectism*, and if left untreated could last for several weeks and death may result eventually [35], [36], [37]. Other symptoms such as cardiac and respiratory include, tachycardia, hypertension, headache, cardiovascular collapse, weakness and chest pain, grunting, respiratory distress, shortness of breath, respectively. The degree or severity of symptoms depends on various factors such as the number of bites, the amount of venom released during the bites and the state and physical condition of the patient. Bites from Black Widow Spider appear to be severe among young children, elderly people or individuals with delicate medical conditions [38]. The grading system for envenomations by Black Widow Spider is described in the Table 1.1.

**Table 1.1 The grading scale for envenomations of *Latrodectus* Black Widow Spider (modified from[38]) .**

Grade	Symptoms
Class A	No systemic symptoms Local pain at the bite site Normal vital signs
Class B	Muscular pain in bitten extremity Extension of pain to the chest or abdomen Local diaphoresis at bite site/ extremity Normal vital signs
Class C	Generalized muscle pain to back, chest & abdomen Diaphoresis distant from bite site/extremity Hypertension/ tachycardia Nausea/ vomiting Headache

The envenomations of Black Widow Spider from mild to moderate can be managed and treated, application of oral analgesics and parenteral opioids alongside benzodiazepines have been used for mild and in moderate to severe cases respectively.

It has been known over a long period of time that venom of a few spiders, especially the Black Widow Spider (*Latrodectus spp*), contain toxins that affect the vertebrate nervous system [34]. The Black Widow Spider Venom (BWSV) contains several large protein toxins (latrotoxins). Latrotoxins are targeted against groups of animals such as vertebrates, insects and crustaceans [13]. The molecular masses of the latrotoxins studied range between 110 and 130kDa and they are large acidic protein (pI~5.0-6.0).

### **Section 1.2.2 Toxin of the Black Widow Spider Venom**

The toxins from BWSV, latrotoxins, have been extensively used to investigate the molecular mechanism of neurosecretion in vertebrates, insects and crustaceans for more than thirty years [13]. It was discovered during the first attempt to isolate  $\alpha$ -latrotoxin from *Latrodectus* species using gel filtration and ion-exchange chromatography that several active toxic components affect crustacean and insect nerve cell terminals [39], [40]). In order to classify and distinguish the toxins, the toxins were named according to the animal groups affected. Seven different latrotoxins have been isolated from *Latrodectus mactans tredecimguttatus* up to date. They include:  $\alpha$ -latrotoxin ( $\alpha$ -LTX) specific for vertebrates with LD<sub>50</sub> of 20-40  $\mu$ g/kg of body weight in mice [[Ushkarev Iu, 1986 #159]] but inactive in insects and crustaceans [41],  $\alpha$ -latrocrustatoxin ( $\alpha$ -LCT) is only active in crustacea, with the LD<sub>50</sub> for crayfish (*Procambarus cubensis*) being 100  $\mu$ g/kg of body weight and doses up to 5 mg/kg harmless for insects and vertebrates. Latroinsectotoxins are targeted against insects, and there are five known examples;  $\alpha$ -latroinsectotoxin ( $\alpha$ -LIT),  $\beta$ -latroinsectotoxin ( $\beta$ -LIT),  $\gamma$ -latroinsectotoxin ( $\gamma$ -LIT),  $\delta$ -latroinsectotoxin ( $\delta$ -LIT)  $\epsilon$ -latroinsectotoxin ( $\epsilon$ -LIT). The LD<sub>50</sub> of LIT on (*Galiera mellonella*) larvae is in the range between 15  $\mu$ g/kg for  $\alpha$ -LIT and 1 mg/kg for  $\epsilon$ -LIT [42], [13].

#### **Section 1.2.2.1 $\alpha$ -Latrotoxin**

$\alpha$ -Latrotoxin ( $\alpha$ -LTX) is the sole component of the black widow spider venom that is responsi-

ble for the toxic effects in vertebrates [14]. The  $\alpha$ -LTX purified from venom glands, is the most widely studied of all latrotoxins and is known to affect vertebrates by inducing massive release of numerous transmitters. The molecular mass of  $\alpha$ -LTX is about 130 kDa with an isoelectric point of 5.5 [43].  $\alpha$ -Latrotoxin has been isolated and purified from black widow spider using fractionation on a Mono Q column. A further isolation of individual protein was performed using a combination of two high-pressure ion-exchange chromatographies with hydrophobic chromatography [44], [45]. The isolation and characterisation of many novel toxins from spider venom have made a considerable contribution to studying physiological processes *e.g* identifying and characterising ion channels, new selective insecticides. Apart from  $\alpha$ -LTX, three additional latrotoxin ( $\alpha$ -insectotoxin,  $\delta$ -latroinsectotoxin and  $\alpha$ -latrocrustotoxin) that act on invertebrates have been cloned and purified from black widow spider. These three invertebrate latrotoxins are homologous to each other and to  $\alpha$ -latrotoxin all over their entire length [2]. The alignment of the sequences of four latrotoxins shows conserved regions extending over the entire proteins with a conserved domain arrangement of latrotoxin genes [43].  $\delta$ -Latroinsectotoxin shares sequence identity of 37% with  $\alpha$ -latrotoxin and a sequence identity of 38% with  $\alpha$ -latroinsectotoxin, whereas  $\alpha$ -latroinsectotoxin shares a sequence identity of 34% with  $\alpha$ -latrotoxin [46]. The latrotoxin molecule is made up of four structural domains as shown in Figure 1.3.

The first domain is a cleaved peptide, made up of 14-38 amino acids. Kiyatkin and his colleagues (1993) have shown that cDNA sequence of  $\alpha$ -latrotoxin lacks a signal peptide, but that secretion of  $\alpha$ -latrotoxin suggests that this peptide is required for secretion. Domain II, is a conserved N-terminal domain consisting of 450-480 amino acid residues, with hydrophobic regions that may be transmembrane segments. The ankyrin-like repeat is Domain III which covers 557-745 amino acid residues. Similar repeats are present in cytoskeletal proteins which are involved in differentiation and transcription processes. The latrotoxin C- terminal domain has about 195-

206 amino acid residues, and is cleaved during maturation of latrotoxin [3], [46], [2].

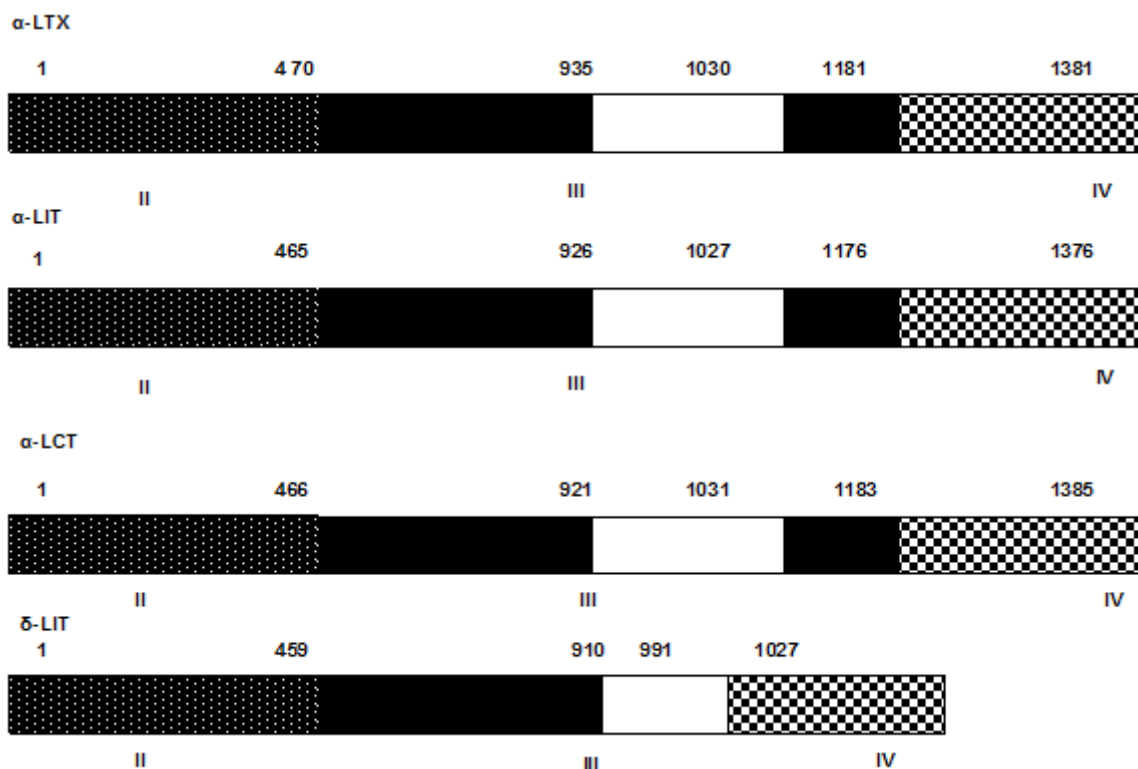

**Figure 1.4 Model of structural domain of the latrotoxins.** The primary structure of latrotoxins is divided into four domains and shows respective amino acid positions. Domain I is not shown; a cleaved signal peptide is removed during synthesis. Domain II is represented in black dotted box for the conserved N-terminal domains. Domain III is represented in black box, less conserved but include the series of ankyrin-like repeats and white box in between shows the highest variation among the types of latrotoxins. Domain IV is the C-terminal, not conserved and proteolytically removed upon the maturation of toxin. Reproduced from [3]

Thus the full-length cDNA of  $\alpha$ -latrotoxin does not yield functional, recombinant  $\alpha$ -latrotoxin; there was no toxic activity obtained when the full-length of  $\alpha$ -latrotoxin precursor was expressed in insect cells using baculovirus vector [2], [47]. The N- and C-terminal sites undergoing proteolysis would produce proteins with molecular masses similar to those of mature latrotoxins, whereas the expression of truncated proteins produced toxins identical to their natural prototypes using SDS electrophoresis and specific activities [13].

The current data provide two models of action on the structures and functional properties of latrotoxins; the toxin tetramer binding to the presynaptic receptor and the formation of a cation

channel as a result of insertion of toxin molecules into the membrane. Precise elucidation of the mechanism of action of  $\alpha$ -latrotoxin will provide a major advancement and insight in our understanding of neurotransmitter vesicle exocytosis [47].

#### **Section 1.2.2.1.1 Dimer and Tetramer formation of $\alpha$ -LTX**

$\alpha$ -LTX was thought to exist as monomers of molecular mass of 130kDa, but under normal circumstance it behaves as larger molecular mass protein of 260kDa [48], [49]. The ability to form dimers and tetramers is probably the most important characteristic of  $\alpha$ -LTX, as its formation of a stable dimer might be due to protein-protein interaction mediated through the presence of C-terminal ankyrin repeats. Ashton and his colleagues (2000) have demonstrated that tetramerisation of  $\alpha$ -LTX was triggered in the presence of  $\text{Ca}^{2+}$  or  $\text{Mg}^{2+}$  (divalent cations) or SDS. The structure of  $\alpha$ -LTX provides information on the functional sites, its 130 kDa monomer has a U-shape with one limb extended radially (Figure 1.5A-B). A frontal section of the latrotoxin tetramer on the extracellular membrane surface is shown, illustrating the presence of a pore (Figure 1.5C). In the model system, the formation of tetramer structure triggers insertion of tetramer into the membrane, and this suggests that the binding sites for the receptor is located in the extended arms [49]. The tetramers are lipid-soluble, unlike dimers, and they are known to be the active form and readily interact with hydrophobic surfaces. They show conformation changes within the monomers during dimer-tetramer transition. During tetramerization or binding of receptor, changes of angle from  $120^\circ$  to  $100^\circ$  occur between two limbs of the U-shape in the destination or region for membrane bilayer insertion. The use of electron microscopy (cryo-EM) for individual image particle analysis has paved the way for determination of structures as small as the 260kDa dimer [49]. The three-dimensional structure (3D) of  $\alpha$ -LTX is likely to share similarity with other latrotoxins, and the 3D structure has shown that the molecule contains three domains rather than the two predicted by sequence information: the wing, the body and the head in each  $\alpha$ -LTX monomer.

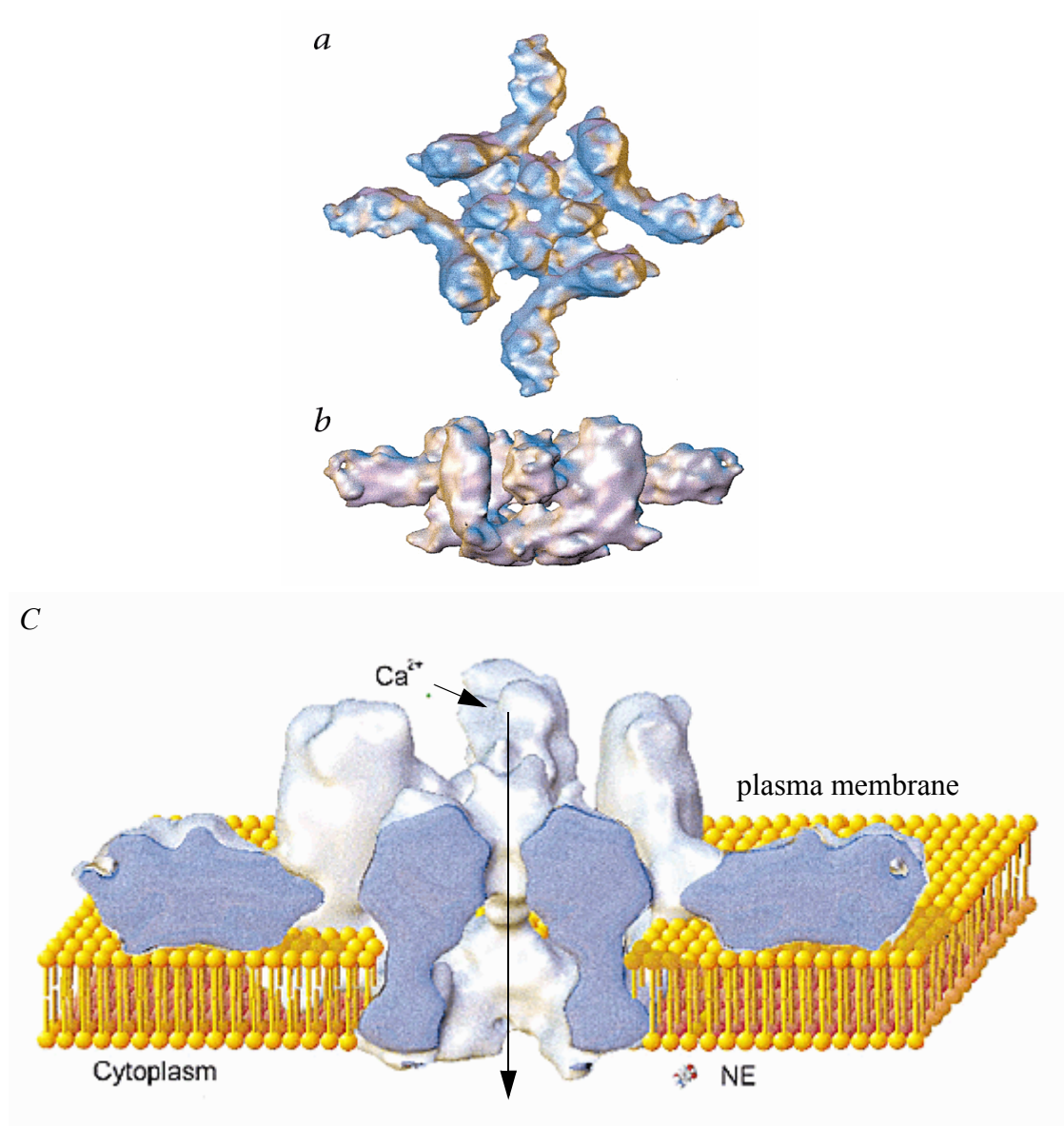

**Figure 1.5 The cryo-EM reconstruction and model system of  $\alpha$ -LTX tetramer .** **a** is the top view of tetramer and **b** is the side view of tetramer. The inner limb of the U-shaped subunits lines the pore . The outer limbs have radially projected outwards extensions. Measurement of latrotoxin square for one side is  $180 \text{ \AA}$  ,  $100 \text{ \AA}$  is the side view height. **c** shows the cut open channel of  $\alpha$ -LTX tetramer in membrane bilayer with wing attached to outer membrane surface for the penetration of tetramer. The arrow shows the entrance of  $\text{Ca}^{2+}$  into the cytosol via the channel with cytoplasm and neurotransmitter norepinephrine (NE) on the left and right scale, respectively. Reproduced from [4]

Another latrotoxin that tetramerises in the presence of trace amounts of SDS is  $\delta$ -LIT, and it does not require divalent cations to undergo tetramerisation.  $\delta$ -LIT exists as a mixture of monomers and tetramers, but tetramer production is reduced compared to  $\alpha$ -LTX, and an application

of an electric field leads to breakdown of oligomer [48]. In spite of this breakdown, the tetramers are known to form pores [46], but the oligomeric structure of  $\delta$ -LIT is yet to be fully understood.

#### **Section 1.2.2.2 Crustacean-specific neurotoxin ( $\alpha$ -LCT)**

$\alpha$ -latrocrustatoxin ( $\alpha$ -LCT) is one of the components for the black widow spider venom with molecular weight of about 120kDa, known to be lethal for the crayfish [50]. Little is known about the understanding of action of  $\alpha$ -LCT on crustacean synapses. It has been previously shown that  $\alpha$ -LCT increases transmitter release from crustacean nerve terminals and earlier investigation described the actions of either whole venom or a 65 kDa crustacean specific fraction, but its relationship with currently investigated 120 kDa  $\alpha$ -LCT on either neurotransmitter junction or stretch receptor is unclear [51]. It was found out that  $\alpha$ -LCT shares many features together with that of  $\alpha$ -LTX on vertebrate synapses, such as calcium independent binding, inhibition of toxin action and dramatic enhancement of spontaneous release. Burmistrov and his colleagues (1997) reported that both electrophysiological and electron-microscopic data showed a strong venom effect on the presynaptic terminals, and that  $\alpha$ -LCT action on the neuromuscular synapse is known to be a good model of crustacean central synapses.

#### **Section 1.2.2.3 Insect-specific neurotoxin ( $\alpha$ -LIT)**

$\alpha$ -latroinsectotoxin ( $\alpha$ -LIT) is a novel insect-specific toxin purified from venom glands of black widow spider containing 1214 amino acids. The molecular mass of mature  $\alpha$ -LIT is approximately 130kDa probably derived from double processing of the N-terminal and C-terminal regions of the primary translation product [3].  $\alpha$ -latroinsectotoxin ( $\alpha$ -LIT) has a similar domain structure to  $\alpha$ -latrotoxin ( $\alpha$ -LTX), showing that these toxins belong to a family of related proteins [46]. The alignment of  $\alpha$ -LIT with that of  $\alpha$ -LTX amino acid sequences shows overall identity of 34.1%, [3].



However,  $\alpha$ -LIT is known to specifically cause neurotransmitter release at insect neuromuscular junctions. Although,  $\alpha$ -LIT has no effect on frog motor nerve terminals at 50nM, it still causes massive increase in transmitter release from blowfly (*Calliphora vicina*) motor nerve terminals at 4nM [41]. The presynaptic effect of  $\alpha$ -LIT depends on the presence of divalent cations in the external medium, since both  $Mg^{2+}$  and  $Ca^{2+}$  increase the transmitter release induced by  $\alpha$ -LIT in  $Ca^{2+}$  free solutions [41]. The binding of  $\alpha$ -LIT to insect nerve membrane is similar to that of  $\alpha$ -LTX binding to bovine membrane in terms of saturation and specificity. Therefore, the phenomenology of  $\alpha$ -LIT action on insects resembles in some aspects described in the action of  $\alpha$ -LTX on vertebrates.

## **Section 1.3**     *Caenorhabditis elegans*

### **Section 1.3.1**     **The experimental model organism *C.elegans***

*Caenorhabditis elegans* is a free-living, transparent, soil nematode, an unsegmented round-worm of the phylum nematoda, developed as an experimental model organism in the early 1960s by Sydney Brenner [52], [53], [54]. *C.elegans* is small (~1mm in length), with a maximum diameter of ~80  $\mu$ m (adult hermaphrodite dimensions). It is easy to culture on agar medium containing *Escherichia coli* as nutrients and has a short generation time (~3 days at 20°C) with adult hermaphrodites giving birth to a large number of offspring (>300) by self-fertilization [52]. The worm is a multicellular organism that goes through a complex process of development, starting with embryogenesis, then continuing to morphogenesis and growth to the adult. As a complex organism, about 40% of *C.elegans* genes are homologous to humans, and it has become attractive to study human diseases. The genome size of *C.elegans* is relatively small (97 Megabases), when compared to humans (3000 Megabases). It was the first multicellular organism which had its entire genome fully sequenced. *C.elegans* as a model organism, has played invaluable roles in understanding a wide range of biological processes such as neural development, sensory processing and behaviour as well as other medical important processes

(ageing) [55], [56]

### Section 1.3.1.1 Sex and Chromosome

*C.elegans* has five pairs of autosomes (chromosome I, II, III, IV, V) and one pair of sex chromosome X. There are two sexes of *C.elegans*: a self-fertilizing hermaphrodite (essentially modified female) has two X chromosomes designated as XX and a male has one X chromosome designated as XO [57].

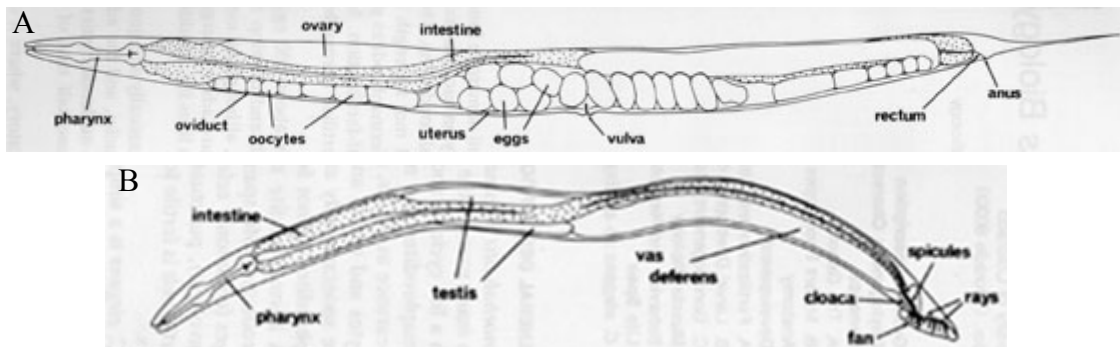

**Figure 1.6 Schematic diagram of two sexes of *C.elegans*, adapted from Wood 1988.** **A** shows the image of self-fertilizing adult hermaphrodite (essential modified female), relatively large with sharp tail and capable of producing both eggs and sperm for production of progeny. **B** shows the image of young male, relatively small with blunt tail and capable of producing sperm only and can be mated to hermaphrodite to produce progeny

The adult hermaphrodite lays eggs controlled by a bilateral pair of neurons called HSN (Hermaphrodite-specific neuron) and males do not lay eggs, so these neurons are absent due to removal at an early stage in development by programmed cell death. Hermaphrodites can self-fertilize or mate with males, producing 50% progeny males and 50% hermaphrodites. In the laboratory, hermaphrodites are self-fertilized or crossed with males to produce progeny of desired genotypes, and these are useful for genetic study of worms. An adult *C.elegans* is made up of a tube, the exterior cuticle with two smaller tubes, the pharynx and the gut and the reproductive system (Figure 1.5). A self-fertilized hermaphrodite has the ability of producing 300-350 offspring or more when mated with males, and this process produces genotypes and phenotypes for genetic analysis [58], [59]. The use of cell-specific markers such as green fluorescent protein

(GFP) and electron microscopy has paved ways for identification and examination of synaptic connectivity of the worm's 302 neurons or individual neurons for detailed analysis of neural functions [55].

### Section 1.3.1.2 Life Cycle

The nematode *C.elegans* has a short-life cycle. The life cycle of *C.elegans* depends on temper-

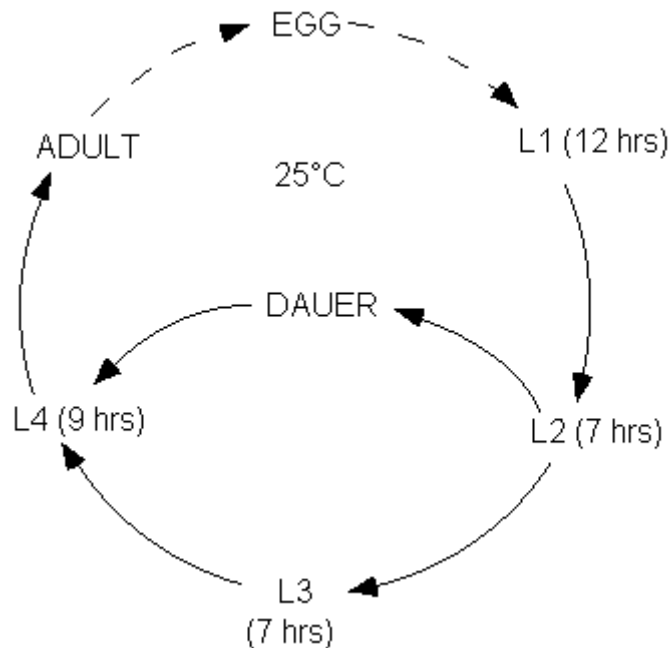

**Figure 1.7 The timing of development and life cycle of *C.elegans*.** The diagram shows the life cycle of *C.elegans* that goes through four larval stages starting from egg to adult in about 35 hours under favourable conditions. An alternative pathway leading to the “dauer” stage arises during development when conditions become unfavorable (low food or crowding). The dauer larvae are capable of living for months in poor conditions and exit the dauer stage and mature to adulthood when conditions become more favourable.

ature for the development of eggs to an adult stage. It has a reproductive life cycle from egg to adult stage of 5.5 days at 15°C, 3.5 days at 20°C, and 2.5 days at 25°C. The fertilization of eggs takes place within an adult hermaphrodite, which thereafter lays the egg at about the 40-cell stage. After hatching of the eggs, animals go through 4 larval stages of development (L1-L4 stage) before the last stage (adult stage), and each adult hermaphrodite lays >300 eggs. The life span of a single hermaphrodite or male *C.elegans* is around 2-3 weeks under normal living condition. Its short life cycle reduces the time required for experiments and facilitates biological study when compared to the use of mice as a model organisms [59], [60]. The shortage of food

on the plate could result in *C.elegans* adopting an alternative developmental pathway known as the Dauer stage, characterised by thin and plugged mouth, inability to eat but with viability maintained for three months.

### **Section 1.3.1.3 Defecation cycle and feeding**

The pharynx plays an important role in *C.elegans* feeding, and pumping of food into the gut is aided by the pharynx made up of 66 different cells and 20 neurons [61]. The two motions that control normal feeding are pumping and isthmus peristalsis [62]. In the first motion, a pump is triggered through simultaneous contraction and relaxation of muscles of the corpus, anterior isthmus and terminal bulb. The open lumen of the corpus is then filled with liquid containing suspended bacteria through the mouth as the posterior isthmus is closed. As the terminal bulb muscles are contracted, bacteria breaks up which allows the debris to be passed to the intestine. This stage is followed by almost simultaneous contraction and relaxation with grinder to its resting position which paves way for closing the lumen of the corpus and expulsion of the liquid and retention bacteria. The second motion involves completion of the relaxation that leads to isthmus peristalsis. The bacteria that are trapped in the anterior isthmus are flushed back to the grinder through peristaltic wave of contraction.

Defecation is defined as periodic activation of muscle contraction of *C.elegans* which involves small number of muscles, a couple of neurons and only one neurotransmitter [63]. *C.elegans* defecation occurs every 45 seconds as controlled by three-motor program; the posterior body muscle contraction (pBoc), the anterior body muscle contraction (aBoc), and the expulsion muscle contraction (EMC) [64]. A well-fed adult hermaphrodite defecates through the contraction of body-wall muscle in four muscle quadrants which stimulate the internal pressure to increase and cause the fluid contents of the intestinal lumen to be squeezed anteriorly. The relaxation of the muscle after 1 minute causes the posterior flow of intestinal contents that seems to collect

in a bolus of the preanal region. The body muscle near the head contracts as soon as relaxation in four muscle quadrants is complete, and the piston-like rigid pharynx is driven by head contraction into the anterior intestine that helps let out the gut content through the anus. Three muscle types (intestinal muscle, anal depressor, anal sphincter) near the anus contract almost simultaneously as soon as contraction of anterior body reaches its climax. The posterior gut is wrapped up by intestinal muscles that seem to pressurize the intestinal contents. This is followed by movement of the anal-depressor muscle that runs from the dorsal wall of the anus to the dorsal body wall, which later contracts to open the anal canal [65]. Before anal muscle contraction, the sphincter muscle is dilated and this causes almost simultaneous contraction of other anal muscles that may act to limit the outflow of lumen contents or squeeze the posterior intestine [66]. There are four anal muscles which are interconnected by gap junctions and they are responsible for the coupled contractions called the expulsion or enteric muscle contraction.

### **Section 1.3.2 The nervous system of *C.elegans***

The adult hermaphrodite of *C.elegans* has 959 somatic cells, some 302 are neurons with 118 distinct classes that form approximately 7000 synapses, of which only five neurons are required for survival and reproduction in culture [67], [68]. The use of electron microscopy helps to reveal the structure and location of muscle and process bundles in the worm. The worm has three process tracts in which the majority of synapses are found and they consist of nerve ring, ventral nerve cord and dorsal nerve cord. Muscle in *C.elegans* is divided into ventral and dorsal which are stimulated by excitatory cholinergic and inhibitory GABAergic neurons respectively. The stimulation pattern occurs such that the ventral muscle is being excited by cholinergic neurons while the dorsal side is being inhibited by GABAergic signaling that facilitates sinusoidal process of the worm. *C.elegans* like many other nervous system, its nervous system is made up of of sensory neurons, interneurons and motor neurons. The cell bodies of motor neuron, sensory and interneurons are found in ventral nerve cord and a set of ganglia in the tail respectively. In-

terneurons control the motor output through synapses onto the motor neurons. These series of interneurons known as command neurons regulate forwards and backwards locomotions of *C.elegans* [69]. The migration and various patterns of cell division generates a complex array of neurons. The cell lineage and expression of downstream genes for the mediation and signalling events of neurogenesis is regulated by neuronal transcriptional factors [70], [67]. Analysis of the mammalian *unc-4* ortholog has been shown to regulate cholinergic motor neurons using electron microscopical reconstruction of identified neurons and behavioral studies in *C.elegans* mutants [71]. The *mec-3* gene in *C.elegans* is known to express in six touch receptor neurons. The *mec-3* gene is important for the differentiation of mechanosensory neurons which are used for the detection of mechanical deformation, and the generation of mechanosensory neurons is regulated by the *mec-3* expression pattern ([72], [70]). The molecular genetic analysis of the *C.elegans* nervous system is very important to understand how the network of gene expression regulated by transcription factors regulates different types of neuronal cells. But the complexity of gene expression seems to exceed other tissues in nervous system. This may depend on the larger number of genes required to mediate the complex activity and function of various type of cells in nervous system.

### **Section 1.3.3    Synaptic function**

*C.elegans* is an important experimental model organism used to study synaptic neurotransmission, identification of the key synaptic proteins and the regulation of synapses [73], [54]. Synaptic transmission is the principal form of communication between neurons; the synaptic junction is a specialised environment where synaptic vesicles fuse with the presynaptic membrane at specific active zone under calcium regulated process in *C.elegans* [74].

During exocytosis, stimulation of synaptic vesicle from nerve terminal involves synthesis, packing, release and re-uptake of neurotransmitter molecule by the neurons for the regulation

of neurotransmitter metabolism and function in *C.elegans*. The vesicle transporters are used to load the classical neurotransmitter such as acetylcholine, serotonin and GABA into synaptic vesicle. This process is followed by the release of neurotransmitters through vesicular fusion, separating the pre and post synaptic cells as it diffuses across the synaptic cleft and binds to receptor on the post synaptic cell. In the endocytosis step, clathrin adaptor is recruited to patch the bud off from the plasmembrane, and in turn binds clathrin that results in a clathrin-coated bud. After this process, the vesicles are uncoated and fused with synaptic endosomes which eventually result in mature vesicles which bud from the synaptic endosomes.

However, the response of the cell to chemical signals is determined by highly specific receptors for transmitters and cell-specific expression. The presence of receptors influences the electrical activity in postsynaptic cells either directly by permitting selective entry of ions or indirectly by activating second-messenger pathways. Plasma-membrane transporters aid the re-uptake of transmitter from synaptic cleft where the signaling pathway is terminated [129], [75].

Using molecular genetics analysis and biochemical characterisation of proteins acting at synapses, mutation have been created and isolated in many genes that encode components of the neurotransmitter release pathway in *C.elegans*. Two strategies used to isolate mutants include screening of behavioural mutants and mutants resistant to neuroactive compounds. It has been demonstrated that several mutants with a synaptic defect are functional and viable, whereas mutants in analogous genes from other model organisms such as *Drosophila* and mice result in lethality [76]. Brenner, 1974 demonstrated that the AChE inhibitor lannate was toxic to wild-type *C.elegans*, and mutant *C.elegans* were resistant to the toxin, e.g. the resistance of *unc-17* mutant to lannate. The use of the AChE inhibitor aldicarb and tricholiform are preferred to lannate in current studies, e.g. the testing of known uncoordinated mutants and selection schemes for toxin-resistant mutants [77], [78]. The toxicity of AChE inhibitor causes over accumulation of excit-

atory neurotransmitter acetylcholine, leading to paralysis or death. Toxins other than AChE inhibitor can be used to select mutants that confer drug resistance due to defects in synthesis, packaging, release and in various aspects of presynaptic acetylcholine metabolism [79], [80].

Synaptotagmin has the ability as a synaptic vesicle protein to stimulate neurotransmitter release in the presence of calcium [81], [82]. Binding of synaptotagmin to BWSV ( $\alpha$ -latrotoxin) is known to trigger neurotransmitter release from synaptic vesicle during exocytosis [83]. There is strong evidence that loss of synaptotagmin impairs synaptic transmission causing behavioral defects, aldicarb resistance, acetylcholine accumulation, and physiological abnormalities observed in *snt-1* null mutants [74]. It has been shown that, the absence of synaptotagmin caused reduction of synaptic transmission during the electrophysiological study of synaptotagmin mutant in *Drosophila* and mice for synaptic transmission, therefore, synaptotagmin is important for the regulation of synaptic transmission. [84], [85].

#### **Section 1.3.4 Latrophilin the *C.elegans* homologue**

Using the *C.elegans* genome database (<http://www.sanger.ac.uk/Projects/C.elegans>), the two possible homologues of latrophilin in *C.elegans* were identified as B0457.1 and B0286.2. However, one of these two homologues B0457.1 shows higher homology to mammalian latrophilin-1. B0457.1 is known as lat-1 and has been shown to have five strongly conserved domains [86]. The *C.elegans* homologue lat-1 and the mammalian lat-1 are both G-protein coupled receptors, with sizeable extracellular and intracellular domains .

The heptahelical transmembrane receptor HC110R from *Haemonchus contortus* is a target for anthelmintic, emodepside and it is homologous to lat-1(B0457.1) from *C.elegans*. This is known to have significant similarity to latrophilins from human, cattle and rat, and a 54kDa amino-terminal fragment binds latrotoxins [87]. Sequence analysis shows that lat-1 has 22%, 23%, and 21% amino acid identities to rat, bovine and human latrophilin respectively. The *C.elegans*



B0457.1 protein lacks an olfactomedin-like region but has several common N-terminal domains (hormone receptor motif, stalk, G-coupled protein proteolysis site). This *C.elegans* lat-1 shows a stronger similarity to vertebrate lat-1 when compared to insect orthologue sequence. Although, neurexin and phosphatase  $\sigma$  are expressed in *C.elegans*, only RNAi knockdown of the lat-1 gene in *C.elegans* were resistant to BWSV ( $\alpha$ -latrotoxin) [86]. It has been shown that *C.elegans* lat-1 mediates the effect of emodepside (anthelmintic drug) on the pharynx, and that the mechanism of effect of emodepside is regulated by coupling to G-protein (Gq $\alpha$ ) and phospholipase C (PLC- $\beta$ ) via the latrophilin-signaling pathway [88]. The latrophilin signaling pathway requires the *UNC-13* protein to stimulate neurotransmitter release by vesicular exocytosis.

## Section 1.4 Summary

Latrophilin is the receptor of greatest interest for the action of BWSV, and it has been widely studied to understand its role with respect to binding and signaling especially in mammals. The genome analysis showed that latrophilin has a close homology to *C.elegans* B0457.1 (lat-1 gene) containing large extracellular domain and a G-protein coupled receptor cytoplasmic tail. However, there is still much to be known about latrophilin with regard to the mechanism of action of BWSV, and the interest in studying latrophilin in *C.elegans* is increasing. Recent findings have shown the importance of latrophilin in mediating the toxicity of BWSV and effect of emodepside in *C.elegans*. However, the difficulty in elucidating the role of latrophilin as a receptor for the BWSV in higher organisms has led to the establishment of *C.elegans* as an experimental organism to study and understand mechanism of latrophilin for BWSV. The use of RNAi experiments has shown that latrophilin is required for the toxicity of BWSV, but due to the tissue-specific nature of RNAi, genetic knock down for latrophilin in *C.elegans* was carried out to elucidate the role of latrophilin. Therefore, a study of the lat-1 gene was investigated in lat-1 knock out *C.elegans*.

## **Section 1.5 Objectives of this Research Project**

The understanding of role of the lat-1 as a receptor for BWSV in *C.elegans* is far from complete. This study is aimed to contribute to our understanding of lat-1 in *C.elegans*. The following are the fundamental questions to be addressed.

### **Section 1.5.1 Where is lat-1 expressed?**

To answer this question, a nuclear tagged Green Fluorescent Protein (GFP)/  $\beta$ -galactosidase gene will be cloned under the control of the lat-1 promoter sequence. When this construct is used to make transgenic *C.elegans*, the resulting worms are expected to show specific staining in the cells where lat-1 is expressed, allowing cell identification during development. If possible, the intracellular localisation of lat-1 may be addressed by adding a C-terminal tag of GFP to the lat-1 gene under the control of its own promoter. In transgenic *C.elegans*, the endogenous localisation of lat-1 will be revealed by visualisation of GFP.

### **Section 1.5.2 What is the phenotype of the lat-1 null worm ?**

A putative nullizygous worm will be obtained, and characterised. Determination of the lat-1 null phenotype will be undertaken by a variety of methods to determine any abnormalities. Determination that these phenotypes are associated with lat-1 can be addressed by creating lat-1 null animals that are transgenic for lat-1.

### **Section 1.5.3 What is the role of latrophilin in BWSV toxicity ?**

The toxicity of BWSV can be determined in wild-type and nullizygous worms. The precise role of the latrophilin receptor can be addressed by making lat-1 nullizygous worms that are transgenic for lat-1, and putative mutants.

## Chapter 2 Materials and Methods

### Section 2.1 Materials

All the reagents were purchased at AnalaR grade purity or greater. LB Broth, Tris Base, Tryptone, Bacto-agar, Bacto-yeast were obtained from Melford laboratory Ltd. Mineral oil, potassium cyanide, ferrous cyanide, ferric cyanide, SDS, potassium acetate, EDTA, hydrogen peroxide, BSA, RNase A were obtained from Sigma. Ammonium sulphate, ethanol, glycerol, methanol were from BDH. Sodium chloride, potassium hydrogenphosphate, sodium hydrogenphosphate, potassium dihydrogenphosphate, acetic acid, chloroform, magnesium chloride, phenol, coomassie blue were obtained from Fisher Scientific. All restriction enzymes were obtained from either Biolabs or Promega. Bis-Tris Gel, MES SDS Running Buffer and Agarose were provided by Invitrogen. *E.coli*, JM109, T4 ligase & ligase buffers, Wizard DNA-clean-up system and other commercial plasmids were obtained from Promega. QIAGEN mini & maxi prep were provided by QIAGEN. Alkaline phosphatase, proteinase K, 1kb ladder, and 1kb+ DNA marker ladder were obtained from GIBCO-BRL. High purity water (18.2 mega ohms) was supplied by Purite select Bio system. Black Widow Spider Venom was provided by Iatocan (France). The Flaming/Brown micropipette puller (Model P-97) was produced by Sutter Instrument Co. The Inverted microscope Axiovert 135TV was produced by ZEISS Germany. The stereo microscope (SZX12) was produced by Olympus Japan. Leitz micromanipulator was obtained from Wetzlar Germany. Filter sets for microscopy such as; mCherry XF102-2 (excitation: XF1067, 560AF55, dichroic: XF 2029, 595DRLP, emission: XF 3081, 645AF75), GFP XF100-2 (excitation: XF1073, 475AF40, dichroic: XF2010, 505DRLP, emission: XF3038, 535AF45), CFP XF1071 (excitation: 440AF21, dichroic: XF2034 455DRLP, emission: XF3079 535AF26) were obtained from Glen Spectra UK. Other chemicals or compounds that were not mentioned were obtained from Sigma, except where otherwise stated in the text.

## **Section 2.2 Methods**

### **Section 2.3 Molecular biology technique**

#### **Section 2.3.1 *E.coli* Cultures**

Luria-Bertani (LB) broth (10g/L Bacto-tryptone, 10g/L NaCl and 5g/L Bacto-yeast extract) with ultra high purity (UHP) water was used as a medium for the growth of *E.coli* cells. Solid media (LB-agar) were prepared by the addition of 15g of agar into LB-broth medium. Prior to use all media were sterilised by autoclaving. Ampicillin (500µl) was added to a final concentration of 100µg/ml to 1litre melted media (after the melted media had cooled down to approximately 55°C) for the growth of strains containing plasmid-borne ampicillin resistance. Cultures were grown overnight in 5ml LB/ Amp at 37°C in the shaker

#### **Section 2.3.2 *E.coli* calcium competent preparation**

*E.coli* strain XL-1 or JM109 was stored at -80°C in 10% glycerol stock. Each tube containing *E.coli* strain XL-1 (tetracycline resistant) or JM109 ( no antibiotic resistance) was thawed and streaked on LB-agar with appropriate antibiotic, and incubated at 37°C overnight. A single colony of XL-1 or JM109 strain was picked and inoculated in 5ml LB-broth with antibiotic added where necessary. The culture was left to grow overnight at 37°C in a shaker. 2.5ml of the overnight culture was added to 250ml of LB-broth in a sterile 500ml clonical flask and incubated with appropriate antibiotic in a shaker at 37°C until it reached an OD<sub>600</sub> of 0.7. After incubation, cultures were allowed to chill for 20 mins on ice after which the cells were centrifuged in a sterile maxi-prep tube at 4000g at 4°C for 15 minutes. The supernatant was discarded and pellet was resuspended in sterile ice cold 0.1M CaCl<sub>2</sub>. Cells were centrifuged another time at 4000g at 4°C for 15 minutes. After centrifugation, the supernatant was discarded and final pellet resuspended in 2ml of sterile 0.1M CaCl<sub>2</sub>, 10% glycerol, then stored in 200µl aliquots at -80°C.

#### **Section 2.3.3 Transformation of calcium competent *E.coli***

100µl aliquots of cells were thawed on ice. 5-10µl ligation reaction or 10-40ng of DNA was

added to the cells and left on ice for 15 mins. The cell mixture was heat-shocked for 90 seconds at 42°C and incubated on ice for 2 mins. Cell mixture were incubated again at 37°C in 1ml of LB for 1hr. After incubation, 100µl of the transformed cells were spread out on 9cm LB-agar petri dishes containing appropriate antibiotics, then incubated at 37°C overnight.

#### **Section 2.3.4 *E.coli* electro-competent preparation**

Colonies were treated using similar approach as in section 2.2.2, apart from the pellet that was resuspended in 50ml of ice cold sterile UHP water after the first centrifugation step. The supernatant was discarded and pellet resuspended in ice cold sterile UHP water, centrifuged at 4000g at 4°C for 15minutes for a total number of five times and the cells were used immediately. Alternatively, cells were resuspended in 2ml sterile ice cold UHP water, 20% glycerol and 200µl aliquots were stored at -80°C.

#### **Section 2.3.5 Transformation of *E.coli* electro-competent**

It is an efficient method of transforming DNA. After ethanol precipitation of DNA or ligation reaction, the tube containing the mixture must be allowed to air-dry in order to get rid of left-over salt in the tube after spinning. A freshly prepared aliquot of thawed JM109 or XL-1 electro-competent cells were mixed with 5-10µl of ligation reaction or 10-40ng of DNA (subjected to ethanol-ammonium precipitation) in a 1.5ml eppendorf tube. The mixture of electro-competent cells and DNA was added to a 2mm diameter electroporation cuvette and electroporated at a voltage of 2.5kV/cm. The cells were immediately resuspended in 1ml of LB-broth, then allowed to recover at 37°C for 45 minutes in a water bath. After incubation in the water bath, 100-200µl of transformed cells were plated out on an agar plate containing appropriate antibiotic.

### **Section 2.4 DNA Extraction and Purification**

#### **Section 2.4.1 Phenol-Chloroform extraction of DNA**

500g of crystalline phenol was melted at 68°C for the preparation of Tris buffered phenol (pH 8.0) and 0.1% (w/v) hydroxyquinoline was added to the solution. An equal volume of 0.5M

Tris-HCl (pH8.0) was added to melted phenol and stirred for 15 mins. The solution was allowed to separate in two phases and the aqueous phase was discarded. An equal volume of 0.1M Tris-HCl (pH8.0) was added to the phenolic phase and stirred for 15 minutes. The solution was allowed again to separate and the phenolic phase was collected and tested. The final extraction was repeated until a phenolic phase pH greater than 7.8 was achieved. After equilibration of phenol, 0.1 volume of 0.1M Tris-HCl (pH 8.0) was added to final aqueous phase that was removed, and solution was stored in this state at 4°C in the dark for 4-6weeks.

Phenol-chloroform was used to remove protein contaminants before precipitation with 100% ethanol. An equal volume of phenol-chloroform was added to DNA solution to be purified in 1.5ml eppendorf tube. The DNA solution was mixed by vortexing and centrifuged at 12,000g for 2 minutes at 4°C. After centrifuging the supernatant was carefully removed and transferred to a fresh tube.

#### **Section 2.4.2 Ethanol precipitation of DNA**

Ethanol precipitation was carried out to recover DNA from solution. Two volumes of 100% ethanol and 1/4 volume of 3M ammonium acetate (pH 5.5) were added to DNA solution in 1.5ml eppendorf tube. The DNA solution was gently mixed and incubated at -20°C for 1-2hrs. After incubation, solution was centrifuged at 12,000g for 10-20 minutes at 4°C. The supernatant was carefully removed and the pellet was resuspended in 500µl of 70% ethanol and centrifuged at 12,000g for 5 minutes. The supernatant was removed and air-dried for 30 minutes after centrifugation. The dried pellet was then resuspended in UHP water.

#### **Section 2.4.3 Alkaline lysis method of DNA preparation**

A single colony from the transformation was inoculated into 5ml of LB medium containing appropriate antibiotics in 25ml tube. The culture was incubated overnight at 37°C with vigorous shaking. After incubation, 1ml of the culture was transferred to a 1.5ml eppendorf tube, centri-

fuged at 12,000g for 30 seconds at 4°C. The supernatant was removed and the bacterial pellet was resuspended in 100µl of ice-cold solution I (50 mM glucose, 25 mM Tris .Cl (pH 8.0), 10 mM EDTA) by vigorous vortexing. Then, 200µl of freshly prepared solution II (0.2M NaOH 1%SDS) was added and mixed by inverting the tube rapidly five times and placed on ice. To this solution, 150µl of freshly prepared solution III (5 M potassium acetate, 11.5% glacial acetic acid) was added to the tube and was vortexed gently for 10 seconds and stored on ice for 3-5 minutes. The mixture was centrifuged at 12,000g for 10 minutes at 4°C and the supernatant was transferred to a fresh 1.5ml eppendorf tube. Equal volume of phenol:chlorom was added, vortexed and centrifuged at 12,000g for 2 minutes at 4°C before transferred to another fresh eppendorf tube. The DNA was precipitated by adding two volumes of ethanol, vortexed and the mixture was allowed to stand for 2 minutes at room temperature before centrifugation at 12,000g for 5 minutes at 4°C. The pellet was then washed in 1ml of 70% ethanol. The supernatant was gently removed and the tube was allowed to dry and the pellet was dissolved in UHP water.

#### **Section 2.4.4 Preparation of DNA using Qiagen mini-prep column**

This method is used for the preparation of plasmid DNA on small-scale and is known to produce high quality plasmid DNA for sequencing, micro-injection and several other purposes. To use this method, a single colony from transformation was inoculated into 5ml of LB broth and incubated overnight at 37°C in a shaker. After incubation, 3ml of the culture was transferred into a tube and centrifuged at 15,000g for 60 seconds at 4°C. The supernatant was removed and the bacterial pellet was resuspended in 300µl Buffer P1 (50mM, Tris-HCl pH8.0, 10mM EDTA, 10mg/ml RNase A added). 300µl Buffer P2 (0.2M NaOH, 1% SDS) was added to the mixture and inverted gently for 4-6 times. To this mixture, 350µl Buffer P3(3M-potassium acetate pH5.5) was added and gently inverted for 4-6 times. The mixture was centrifuged at 15,000g for 15 minutes forming a compact white pellet. While centrifugation was going on, QIAgen-Tip

20 was equilibrated with 1ml of buffer QBT (750mM NaCl, 50mM MOPS pH7.0, 15% ethanol and 0.15% Triton X-100) and was allowed to drain through the column. The supernatant was gently removed and transferred to the QIAgen-Tip 20 column and was allowed to drain through the column. The column was then washed 4 times with 1ml of buffer QC (1.0M NaCl, 50mM MOPS pH 7.0 and 15% ethanol). The plasmid DNA in the column was eluted by adding 0.8ml of buffer QF (1.25M NaCl, 50mM Tris-HCl pH 8.5 and 15% ethanol) and collected in a fresh eppendorf tube. The DNA collected was then precipitated in 0.7 volumes of isopropanol and left at room temperature for 20 mins. The DNA solution was centrifuged at 15000g for 30 mins, then washed in ice cold 70% ethanol. After centrifugation, the supernatant was removed and the pellet was allowed to air-dry before resuspension in 30µl of UHP water.

#### **Section 2.4.5 Preparation of DNA using Qiagen-tip 500 maxi-prep column**

A Qiagen-tip 500 maxi-prep column is used for large-scale preparation of high quality plasmid DNA. A litre conical flask containing 500ml of overnight culture was used for this purpose and a similar approach as described in section 2.3.4 was used according to the manufacturer's instructions. Because it is a larger volume, the recovered DNA was resuspended in 250µl of UHP water and stored at -20°C for long-term use.

#### **Section 2.4.6 Preparation of Cosmid DNA**

The cosmid vector is known to contain foreign DNA inserts and replicates more slowly than smaller plasmid in culture due to its large size of up to 45kb. This protocol is a scaled-up version of of 50ml maxi-prep protocol with yields ranging from 50µg-100µg of cosmid DNA. It requires 2 overnight steps to amplify the cultures and half a day for DNA preparation. First day, a freshly streaked single colony was inoculated into 5ml of LB medium containing the appropriate antibiotic and incubated at 37°C overnight in a shaker or on a roller drum. On the second day, 1000µl of the overnight culture was inoculated into 1Litre sterile glass flask containing 500ml of LB medium containing appropriate antibiotic and incubated overnight at 37°C with



vigorous shaking (~200 rpm). On the third day, the overnight culture was transferred to a maxi-prep tube and centrifuged at 6000g 15 mins at 4°C. At this stage, RNase A 10mg/ml was added to the supernatant collected after centrifugation and mixed gently, then incubated on ice for 10-20 mins. Addition of RNaseA at this stage before treatment with buffers completely digested all the RNA present in the cosmid when compared to the sample without addition of RNase A. Subsequent treatment with buffer was carried out as described in section 2.3.4. according to the manufacturer's instructions. The final pellet was resuspended in 500µl of TE (pH 8.0) containing 0.02mg/ml RNase A and incubated at 37°C for 30mins. A 10µl aliquot of DNA was run on 0.8% TAE agarose gel against concentration standards to check for purity and yield.

#### **Section 2.4.7 Restriction enzyme digest of plasmid DNA**

A total reaction volume of 30µl was set up for restriction digest containing 1-4µg of DNA, 1-2µl of restriction enzymes and 3µl of 10X buffer and making up the final reaction with UHP water. The mixture was incubated at 37°C for 1-2hrs. After incubation, the sample was checked by agarose gel electrophoretic analysis.

#### **Section 2.4.8 DNA agarose gel electrophoresis**

DNA was analysed on 0.8-1.0% w/v agarose gel in 1XTAE (40mM Tris-HCl, 1mM EDTA, 5.70% glacial acetic acid). Agarose was heated in microwave to dissolve in 1XTAE and was allowed to cool down until temperature reaches 55°C. After cooling down, ethidium bromide at 10mg/ml was added to a final concentration of 0.5µg/ml. The agarose gel solution was poured into the gel casting mould with the right size of forming comb and was allowed to set before it was placed in electrophoresis tank containing running buffer (1XTAE). DNA samples were mixed with 10% loading buffer (30% glycerol, 0.25% bromophenol blue, 0.25% xylene cyanol FF) and loaded alongside markers of known sizes (1kb and 1kb+ DNA ladders). DNA electrophoresis was carried out for 30-60 minutes at 100V until the blue dye had migrated 2/3 of the length of the gel. DNA bands were visualised under a UV trans-illuminator and pictures were

taken using a Bio-Rad Gel-Doc

#### **Section 2.4.9 DNA purification using QIAEX II gel extraction kit**

The DNA purification from 0.8-1.0% agarose gel in 1xTAE buffer (40mM Tris-HCl, 1mM EDTA, 5.71% glacial acetic acid) was carried out using QIAEX II gel extraction kit. Gel extraction of DNA was done by following manufacturer's instruction. The QIAEX II gel extraction kit contains silica particles which bind freely to DNA, without contamination. The DNA band was excised from the gel using a clean scalpel and transferred into clean eppendorf tube. The gel slice was weighed in the tube and 3 volumes of QX1 buffer was added to the gel. The tube was incubated at 50°C for 10 mins to solubilize the gel and allow the DNA to bind to silica particles. During the incubation, the tube was vortexed every 2mins to keep QIAEX II in suspension. The sample was centrifuged at 15000g for 30-60s after incubation and supernatant was removed. 500µl of QX1 buffer was added to the resultant pellet and vortexed before centrifugation at 15000g for 30s. The supernatant was removed and the pellet was washed twice in 500µl of PE buffer to remove salt contamination by centrifugation at 15000g for 30s. After removing the supernatant, the pellet was air-dried for 30mins and 10µl of 10mM Tris pH 8.0 was added and re-suspended by vortexing. The sample was incubated at room temperature for 10mins to elute the DNA from the silica complex. After 10mins incubation, the sample was spun down at 15000g for 30s, the supernatant was carefully removed and the pellet was resuspended in UHP water and kept at -20°C.

#### **Section 2.4.10 *C.elegans* genomic DNA extraction**

Worms were washed-off the NGM plates overlaid with 1% agarose (agar contains material that inhibit enzymatic manipulation of DNA) with water and transferred into 5ml centrifuge tube. The tube was spun down at 3000 rpm for 2 mins and supernatant was removed before adding 5 volumes lysis buffer (0.1M Tris-Cl pH 8.5, 0.1M NaCl, 50mM EDTA, 1% SDS, aliquots kept at -20°C and proteinase K 0.1mg/ml was added before use) to the resultant pellet. After adding

lysis buffer, the tube was incubated at 65°C for 2hrs and the tube was further incubated at 95°C for 20-30 mins. The RNase 0.1mg/ml (DNase free) was added to the mixture and incubated at 37°C for 1hr. After incubation the sample was extracted for 3times with 1 volume phenol/chloroform. To this sample, 0.1 volume of 3M sodium acetate and > 2volumes of 100% of ethanol were added, mixed and incubated at room temperature or at -20°C for 1hr. The sample was centrifuged at 14000rpm for 15 mins after incubation. The supernatant was removed after centrifugation and pellet was washed with 70% ethanol. Ethanol was removed and pellet was allowed to air-dried before resuspension in UHP water or TE buffer. The *C.elegans* DNA extracted at this stage is clean enough for restriction digest but further purification is required for micro-injection.

#### **Section 2.4.11 Purification of DNA using Wizard DNA Clean-up system**

The Wizard DNA clean-up system was used for further purification of *C.elegans* DNA extracted using the method described in section 2.4.10. Purification of DNA was carried out using manufacturer's instruction. 400µl of Virtual Lysate Mixture [(150µl GTE;50mM glucose, 25mM Tris-Cl pH 8, 10mM EDTA), (150µl 1M NaOH/0.1%SDS), (150µl 5M KOAc;3MKAc& 2MHAc), SDS and KOAc form precipitate which can be removed by spinning at 14000rpm for 5mins] was added to 20µg-40µg of DNA. To this mixture, 1ml of suspended Promega Wizard prep resin (in manufacturer's resin suspension solution) was added to tube and mixed gently by inverting 3-5times. The sample mixture was loaded into 3ml syringe fitted into the column. The manufacturer's instructions were followed for washing and recovery of DNA from the column. After washing and recovery of DNA from the column, ammonium acetate was added, followed by phenol/chloroform extraction and ethanol precipitation before resuspension in 20µl of TE or UHP water.

#### **Section 2.4.12 DNA treatment using alkaline phosphatase**

Shrimp alkaline phosphatase (SAP) is an enzyme used to remove the 5'-terminal phosphatase

from nucleic acid. Alkaline phosphatase prevents recircularising of linearised cloning vectors by dephosphorylation. A total volume of 20 $\mu$ l is set up for alkaline phosphatase treatment; 10 $\mu$ l of DNA sample, 2 $\mu$ l of 10X shrimp alkaline phosphatase buffer (0.2M Tris-HCl (pH8.0), 0.1M MgCl<sub>2</sub>) and 1 $\mu$ l SAP (1 $\mu$ l/ $\mu$ g DNA) and UHP water was added to make up final volume of 20 $\mu$ l. The reaction mixture was incubated at 37°C for 15-30mins (works for both 5' and 3' overhangs or blunt ends) . After incubation, the reaction mixture was heat inactivated at 65°C for 15 mins. The final reaction can be used directly for ligation reaction or can be further cleaned up using phenol:chloroform extraction after which ethanol precipitation is carried out to recover the pellet DNA.

### **Section 2.4.13 Ligation of DNA**

The process of introducing DNA fragments of interest into plasmid vectors using DNA ligases is known as a ligation reaction. The formation of a phosphodiester bond between adjacent nucleotides (5'-phosphate and 3'-hydroxyl group of DNA) with hydrolysis of ATP to AMP occurs during ligation. Using the correct balance between ratio of insert DNA to vector DNA is important for a successful ligation. For ligation set up, the vector and insert DNA were usually mixed in a 1:3 molar ratio. The total reaction volume used was 10 $\mu$ l; 1 $\mu$ l vector, 3 $\mu$ l insert DNA, 1 $\mu$ l T4 DNA ligase, 1 $\mu$ l 10X buffer ( 250mM Tris-HCl pH 7.6, 50mM MgCl<sub>2</sub>, 5mM DTT, 25% (w/v) PEG-8000) and UHP water was added to make up final volume of 10 $\mu$ l. The tube containing the DNA solution was gently mixed by flipping. The reaction was incubated at 4°C overnight for transformation.

### **Section 2.5 Polymerase chain reaction (PCR)**

The polymerase chain reaction is a technique for amplifying a specific sequence in DNA by repeated cycles of synthesis driven pairs of reciprocally oriented specific primers. This method can be used to make multiple copies of DNA. Base-pair mismatches were introduced into the

primers to generate particular restriction enzyme sites. Each amplification reaction contained 200ng of genomic DNA or cDNA using 1µl each as a template, 1µl 5' primer (~70pmol), 1µl 3' primer (~70pmol), 5µl of 10X Extensor Buffer 1(22.5mM MgCl<sub>2</sub>), 0.5µl of Extensor Hi-Fidelity PCR Enzyme Mix (5U/µl)<sup>2</sup>, 5µl of dNTPs (5mM of each dNTP), and was diluted to 50µl with UHP water. A negative control contained all other reagents apart from DNA templates. The PCR reaction was overlaid with 60µl of mineral oil to prevent evaporation taking place in the reaction. PCR was carried out on a Perkin Elmer DNA Thermal Cycler 480 for 25 cycles at 2 minutes denaturing at 95°C, 1 minute annealing at 50°C-70°C (depending on the primers) and 1 minute polymerisation at 72°C, 10 minutes extension temperature at 72°C. The PCR reaction was run on 0.8% agarose (TAE) gel electrophoresis alongside a marker and negative control to confirm the amplification of PCR product.

Conditions:-

95°C for 1 minute (1)

50°C for 1 minute (2)

72°C for 1 minute (3)

Step 1-3 are repeated for 30 cycles

55°C for an additional 5 minutes

72°C for an additional 10minutes

### **Section 2.5.1 Purification of PCR products**

PCR products to be purified were run on 0.8-1.0% agarose gels 1X TAE at 100V for 30-60 minutes. The bands corresponding to the correct size of the fragments were visualised on the Dark

Reader and excised from agarose gels with a clean scalpel. The gel slice was weighed in a colorless tube and 3 volumes of buffer QG was added to 1 volume of gel (100mg ~ 100µl), incubated at 50°C for 10 minutes and the reaction was vortexed for 2-3 minutes to dissolve properly. After incubation, the color of the mixture was checked if it was similar to yellow buffer QG and ensured that the gel slice was dissolved completely. One volume of isopropanol was added to increase the yield of DNA fragment <500bp and >4kb. Sample was applied to QIAquick spin column that was provided in a 2ml collection tube and centrifuged at 12,000g for 1 minutes. After centrifugation, the flow-through was discarded and the QIAquick column was placed back in the same collection tube. The addition of 0.5ml of buffer QG to QIAquick column was optional, this was done to remove all traces of agarose. To wash, 0.75ml of buffer PE was added to QIAquick column and centrifuged at 12,000g for 1 minute, the flow-through was discarded and further centrifuged at 12,000g for additional 1 minute to get rid of residual ethanol. The QIAquick was placed in 1.5ml eppendorf tube, and 50µl of buffer EB (10mM Tris-Cl, pH8.5) was added to the centre of the QIAquick membrane and centrifuged at 12,000 for 1 minutes. The DNA was stored at -20°C for future use.

## **Section 2.6    *C.elegans* Methods**

### **Section 2.6.1    Growth and Maintenance of *C.elegans***

*C.elegans* was maintained on Nematode Growth Medium (NGM) agar and kept at temperature between 15°C and 25°C for growth or development during the experiment. NGM agar was prepared using following reagents; 3g NaCl, 17g agar and 2.5g peptone dissolved in 975ml of distilled water, then autoclaved for 50 mins. The mixture was cooled at 55°C in water bath for 15mins after cooling, these reagents(1ml 1M CaCl<sub>2</sub>, 1ml 5mg/ml cholestrol in ethanol, 1ml 1M MgSO<sub>4</sub>, 25ml 1MKP<sub>0</sub><sub>4</sub> buffer) were added and swirled to mix well. NGM solution was dispensed into 3cm or 9cm petri plates 2/3 full of agar using sterile technique and the plates were seeded with an E.coli OP50 lawn. The seeded plates were allowed to air-dry under sterile con-

dition before incubation at 37°C overnight. After incubation, the plates were ready for the manipulation of *C.elegans* or were left in an air-tight container at room temperature which are usable for 2-3 weeks.

### **Section 2.6.2 Culturing of *C.elegans***

*C.elegans* can be cultured by transferring from one petri plate to another using different methods under a dissecting stereomicroscope (standard 10X eyepieces with magnification of 0.6X to 50X). The chunking method is relatively easy and fast, a scalpel sterilized with flame and allowed to cool is used to transfer a chunk of agar from old plate (containing hundred of worms) to the fresh plate where they feed on bacteria (*E.coli* OP50) and multiply in number. The worm washing method involves washing an old starved plate with sterile water and transfer the washing into an eppendorf tube and placing on ice for 5-10 mins. After 10 minutes the worms settled at the bottom of the tube and the water is carefully removed without disturbing the worm pellet. Worm pellets are then distributed on fresh plates. Another method is the use of worm picker to pick a single animal from one plate and transfer it to another. A worm picker can be made by attaching 0.5-1.0 inch piece of gauge platinum wire into the tip of pasteur pipette over the flame until it becomes melted and glued to the pipette. The worm picker is then ready to be used by flaming and cooling (to avoid contamination) each time a worm is being transferred. As a starter, it takes a bit of experience to use worm picker as holes are likely to be created in an attempt to pick the worms, therefore worms crawl into the holes and this makes it difficult to see or pick them. This problem can be avoided by gently rubbing the tip of worm picker on the edge of bacteria lawn to touch the worms and pick them.

### **Section 2.6.3 Worm Harvesting**

Worms were washed off the culture plates with 5-10mls of M9 buffer ( $\text{KH}_2\text{PO}_4$  3g,  $\text{Na}_2\text{P}_0_4$  3g, NaCl 5g, 1M  $\text{MgSO}_4$  1ml in 1litre distilled water, sterilized by autoclaving and store at 20°C ) or K-medium (KCl 2.39g, NaCl 3.09g in 1litre distilled water, sterilized by autoclaving and

store at 20°C ) and allowed to shake or swirl for a few seconds before pipetting into 50ml centrifuge tube . The same steps were repeated again and pipetted into the 50ml tube. Worms were spun down at low speed for 1 minute or placed on ice for 20-30mins. The supernatants were removed and washed with M9 or K-medium 2 or 3 times to remove as much bacteria as possible. Finally, worms were spun down for 1 minute or placed on ice for 20-30mins to remove the supernatant with some liquid left in the worm pellet before stored at -80°C until it is ready to be used.

#### **Section 2.6.4 Removal of contamination and egg isolation of *C.elegans***

Presence of contaminants such as yeast and bacteria make the scoring and transfer of worms difficult on the culture plates, even though they don't harm the worm. Therefore, it is important to remove the contaminants. Contaminated culture plates that have gravid hermaphrodites were washed with distilled water and collected in 5ml centrifuge tube. Worms were treated by adding freshly prepared 5% bleaching solution (200µl sodium hypochlorite, 100µl 5M NaOH, 700µl H<sub>2</sub>O, mixed by vortexing) into the centrifuge tube and vortexed for 5-10mins. After vortexing, the tube was centrifuged at 1300g for 30-60seconds to release pellet eggs. The supernatant was removed and left liquid up to 0.1ml in the tube containing pellet eggs. 5ml of distilled water was added to the pellet eggs and spun at 1300g for another 30-60seconds. The supernatant removed and pellet eggs isolated was transferred on bacteria plates seeded with bacteria lawn (*E.coli* OP50) using sterile pasteur pipette. Culture plates were left at 20°C to hatch into larvae.

#### **Section 2.6.5 Synchronization of worms**

Isolated eggs (section 2.6.4) were transferred into sterile 500ml flask containing 100-300ml of M9 buffer (section 2.6.3) and allowed to incubate at 20°C overnight with gentle shaking to obtain larval 1 starved animal. On the second day, the flask was placed on the ice to allow the worms to settle down and most of the liquid was removed. The remaining liquid was transferred to 50ml centrifuge tube and spun at 1300g for 60mins to pellet the worms. Pellet worms were



transferred to 100-300ml of S-basal medium (5.85g NaCl, 1g K<sub>2</sub>HP04, KH<sub>2</sub>P04, 1ml cholestrol [[5mg/ml in ethanol]]) in 1litre distilled water, sterilized by autoclaving and store at 20°C) inoculated with concentrated *E.coli* OP50 in 500ml flask. This was monitored by checking a drop of culture under the microscope, and the following harvests were collected many hours later; almost 8hrs a mid-larvae 1 was harvested at 20°C, almost 18hrs a mid-larval 2 was harvested at 20°C, almost 28hrs a mid-larval 3 was harvested at 20°C and almost 37hrs a mid-larval 4 was harvested at 20°C. A small scale sychronization was carried out by transferring the eggs into 3cm or 9cm plate containing 1ml or 9ml of M9 buffer (section 2.5.3) respectively and was incubated at 20°C overnight, followed by transferring starved L1 animals on bacteria (*E.coli* OP50) seeded plate.

#### **Section 2.6.6 Freezing of worms**

*C.elegans* can be frozen and stored at -80°C indefinitely [54]. The majority of starved L1 animals survived from mixed population of frozen worms. Animals that are well fed including adult and eggs did not survive the freezing. Bacteria seeded plates containing mostly starved L1 animals and other stages of worm were washed off with S basal medium (section 2.5.5) and transferred into 5ml tube. The tube was placed on ice for 10-20mins to allow worms to settle at the bottom of the tube. Liquid was gently aspirated to 1.5ml to avoid touching the pellet worms. An equal volume of freezing solution 1.5ml ( 1M NaCl 200ml, 1M KP0<sub>4</sub> pH6.0 100ml, glycerol 600ml in 2litres distilled water, distributed into 200ml, sterilized by autoclaving. add 0.06ml sterile 1M MgSO<sub>4</sub> per 200ml bottle ) was added to the 1.5ml pellet worm in S basal medium. 1ml of mixture was aliquoted into the labelled cryotubes and stored at -80°C for future use. The following day at least 12hrs later, one cryotube from -80°C was thawed and transferred on NGM plate to ensure enough worms survived.

#### **Section 2.6.7 Imaging**

The Stereo Microscope (SZX12) or the Inverted Microscope Axiovert (135TV) were used for

imaging with different types of filters. The pictures of worms were taken using the following set of filters; mCherry filter has red-fluorescence (XF102-2), GFP filter has green fluorescence (XF100-2), CFP filter has blue fluorescence (XF1071). The magnification used was between 40x-100x.

### **Section 2.6.8 Mounting worms for imaging**

The method given below was used for the observation of worms using appropriate GFP filter or DIC microscopy as described in section 2.6.7. 3% agarose was boiled in water and kept warm on a heating plate. A clean sandwiched slide was placed between the two taped slides on a flat surface. Using a pasteur pipette, a drop of agar was placed on the clean slide and the agar was covered with another clean slide placed on top of three slides in a perpendicular fashion. The slide on top was pressed gently to flatten the dropped agar to a circle about 0.4mm thick. Air bubble was avoided in the agar in order not to create space for worms to stick in. The taped slides were gently pulled as soon as agar solidified and the remaining two slides by sliding relative to one another were separated. Agar pad adhered to one of the slides particularly the bottom one in most cases and the slide with agar pad was rested up on the bench top until ready to be used. Worms can be mounted by placing a 1-2 $\mu$ l drop of M9 buffer or water containing 10-25mM sodium azide ( $\text{NaN}_3$  anesthezes the worm so that worm can not move around) onto the middle of agar pad. On the drop of sodium azide, the worm was placed and covered with a cover slip for observation under the microscope.

### **Section 2.7 Transformation of *C.elegans***

DNA transformation is an important tool for *C.elegans* manipulation. This has been used to over-express gene or express tagged protein and also to study the function of a protein domain under the control of its regulatory elements. Transformation has widely employed the use of micro-injection for introducing DNA into *C.elegans* [89]

### Section 2.7.1 Micro-injection of Dextran into *C.elegans*

Worms mounted on an agar pad were injected with fluorescently labelled rhodamine-dextran (70,000 MW). The injection of dextran was targeted into the gonad of adult worms and observed for red fluorescence under mCherry filter microscope. 20-30 worms were injected with dextran to test the penetration and consistency of gonadal injection.

### Section 2.7.2 Micro-injection of DNA into *C.elegans*

Micro-injection is a relatively simple proven method for introducing DNA into *C.elegans* ([90], [91]). In *C.elegans*, the occurrence of transformation requires efficient micro-injection of DNA into syncytial gonads where extrachromosomal arrays are formed. An adult *C.elegans* hermaphrodite has two distal arms of the gonad; each gonad has a syncytium made up of cytoplasm surrounded by germ line nuclei that form oocytes (two U-shaped arms). Micro-injection of DNA into immature oocyte nuclei produced high level of germline transformation compared to micro-injection of DNA into mature oocyte nuclei (cytoplasm) as shown in Figure 2.1 ([91] [92]). Therefore, targeting syncytial gonads (immature oocyte) is vital to the successful transformation of *C.elegans*.

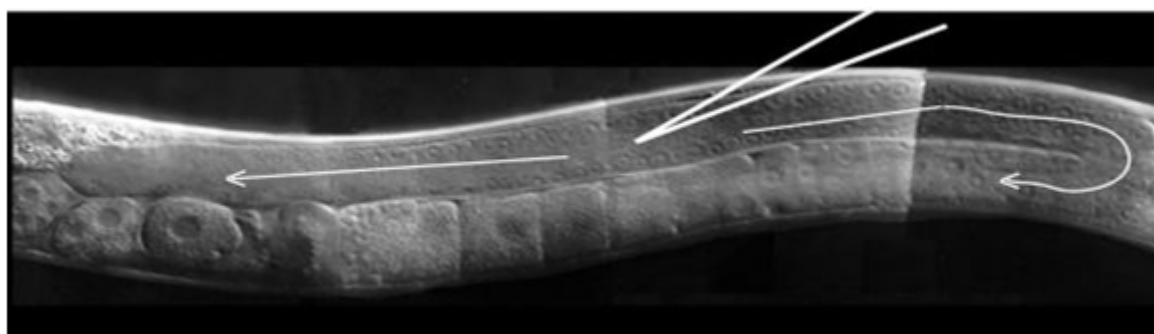

**Figure 2.1 The Syncytial gonad of *C.elegans*** . The image shows the syncytial gonad of *C.elegans* hermaphrodite. The first arrow shows immature oocytes surrounded by germ line nuclei with direction of needle for micro-injection, and this particular area is always targeted for injection that leads to high level of germline transformation. The second arrow shows the U-shaped arm of mature oocyte nuclei (cytoplasm) and the germline transformation is relatively low. This image is extracted from wormbook.

Transformation of *C.elegans* using the relative new technique of gene bombardment has been shown to integrate transgenes into genome at low copy number when compared to micro-injec-

tion [93]. Although, micro-injection of DNA into *C.elegans* is technical demanding but offers so many advantages over gene bombardment. The sequential processes required to carry out a successful micro-injection are summarised below.

### **Section 2.7.2.1 Agarose pad preparation**

The use of an agarose pad is important for micro-injection. The pad is prepared by dropping 2% agarose boiled in water on the center of cover slip (24x50mm) using a pasteur pipette and gently place another cover slip on the top. This idea of placing the cover slip on the top flattens the hot agarose into a thin pad and must be carefully done to avoid air-bubbles. After 2 mins, one of the cover slips was gently removed and allowed to incubate at 37°C overnight. On the next day, the pad was baked in vacuum drying chamber for 2-4hrs before use. Agar pads can be stored in petri plate or coverslip box for several months until it is ready to be used.

### **Section 2.7.2.2 Mounting of worms on agar pad**

It is very important to be able to mount worms on agar pad and recover them with standard M9 buffer (5mM Hepes 7.2, 3mM CaCl<sub>2</sub>, 3mM MgCl<sub>2</sub>, 66mM NaCl, 2.4mM KCl, 4% (w/v) glucose in 1 litre of distilled water, sterilized by autoclaving and stored at 4°C) before micro-injecting with DNA of interest. To mount the worm for practice, an agar padded slide was moistened by breathing a couple of times and a drop of mineral oil or halocarbon oil was placed on the moistened agar pad. A young adult hermaphrodite was picked with a worm picker and placed on top of oil on agar pad and gently dragged to straighten it for gonad to be visible enough. This was repeated for 3 or 4 worms on the same agar pad with oil on it. After 2-4mins, all the worms mounted on the agar pad were recovered with M9 buffer and recovered worms started wiggling in the M9 buffer. The recovered worms were transferred to different NGM plates seeded with *E.coli* OP50 and allowed to incubate at 20°C for 2-3hrs. Worms that recovered were identified through laying of eggs and the worms that did not recover were either slow in movement or

failed to lay eggs as a result of injury suffered or stayed too long on the agar which made them to dry out. The recovery of worms with M9 buffer after mounting was estimated to be between 60-100% for an average of 20 worms mounted, successful mounting can be achieved with regular practice

### **Section 2.7.2.3 Preparation of Micro-injection needle**

The needle for micro-injection must neither be too short nor too long but rather has to be perfect and sharp for good penetration into the worms. Micro-injection needles were produced using a mechanical needle puller (Flaming/Brown micropipette puller Model P-97). Setting up an appropriate parameter for needle-pulling is vital for making a good needle. The needle-pulling parameters (heat, pull, velocity and time) must be adjusted in a “trial and error” manner. During the experiment, the parameters used for needle-pulling is stated as follows; Heat-660, Pull-60, Velocity-100, Time-200, and this gave approximately ~2mm for the length of the needle mouth. However, I noticed that the parameters were altered when the heating elements of needle puller became naked, therefore the needles produced were shorter. After the replacement of the old heating element with new one, the parameters such as Heat and Pull only were slightly increased or lowered regardless of whether the previous Heat and Pull were altered or not. No changes of Velocity and Time were made, replacement of heating element did not affect these two parameters only (take note). This alteration of needle caused by replacement of heating element has been confirmed by another colleague as the problem. To make the needle, the glass filament was inserted under aluminium foil of the needle puller without touching filament to the heating element (to avoid damage) and both ends were gently clamped with the knob on each side. The start button was pressed (make sure the settings are checked and correct before pressing the start button) and needles were pulled within 60 seconds. The pulled needles were stored by resting across the clay with both ends standing free in the box to the hold needles.

#### **Section 2.7.2.4 Loading of DNA solution into the needle**

The loading of the needle with DNA solution was done by pulling a 20 $\mu$ l pipet capillary over an ethanol flame until it became a long-stretched thin tip. This was cut-off with sterile razor until it was about 3cm long, to make needle filler. Micro-injection DNA prepared by mini or maxi-prep (section 2.3.4) and further ethanol precipitation for the recovery of cleaner DNA (section 2.3.2) is important for *C.elegans* transformation. Ethanol precipitation of DNA is resuspended in TE buffer (1M Tris-HCl 1ml, 0.5M EDTA 0.2ml in 100ml of distilled water, filter-sterilize and stored at 4°C) instead of distilled water for micro-injection. The average concentration of DNA for micro-injection during the experiment was between 20-50 $\mu$ g/ml to obtain transgenic animals. Co-injection of two different plasmid DNAs used various ratios, it was either ratio of 1:1 for plasmid A (DNA of interest) and plasmid B (selectable marker) respectively or ratio 1:3 for plasmid A (DNA of interest) and plasmid B (selectable marker) respectively. The DNA solution for micro-injection was loaded by inserting the needle filler to draw DNA from the tube to fill the needle by capillary action. This was carefully done to avoid air-bubble and the needle was placed in vertical of needle holder until the DNA solution drew to the tip without space in between .

#### **Section 2.7.2.5 Mounting and breaking of the needle**

A loaded needle was mounted onto a micromanipulator and the needle was positioned such that it was in the centre of the inverted microscope's field of view. The needle was slightly resting on the edge of rough surface of agar pad that contains a drop of mineral oil under 10X objective using X-Y control of micromanipulator. As soon as it was positioned, the objective was changed to 25X or 40X and the needle was gently being rubbed against the rough surface of agar pad once or twice to break the needle and at the same time applying the pressure until the DNA solution starts flowing. Once the flow of DNA solution was continuously achieved within 1 or 2mins of the break of needle by applying the pressure, it showed the break was good and there-

fore, it can be used for injection.

### Section 2.7.2.6 Micro-injection technique and worm recovery

This is one of the most important aspect of micro-injection and every step has to be carefully done. Before micro-injection started, I ensured that the valve of the pressure tank and regulator were switched on. The injection pressure was set to be approximately 500hPa (7psi) to regulate the influx of DNA solution. Micro-injection of worms began by filling the needle with DNA solution and mounting on the micromanipulator. The needle was broken as described in section 2.6.1.5. and broken needle was lifted out of the mineral oil. 2 or 3 worms were mounted on agar pad as demonstrated in section 2.6.1.2. The mounted worms were placed on the microscope stage and the 10X objective was used to find the worms. Using the micromanipulator, the needle was brought into the same focal plane and the worms were oriented at a 30° or 45° angle to the direction of needle. The magnification was changed to 40X objective and syncytial gonad was brought into focus.

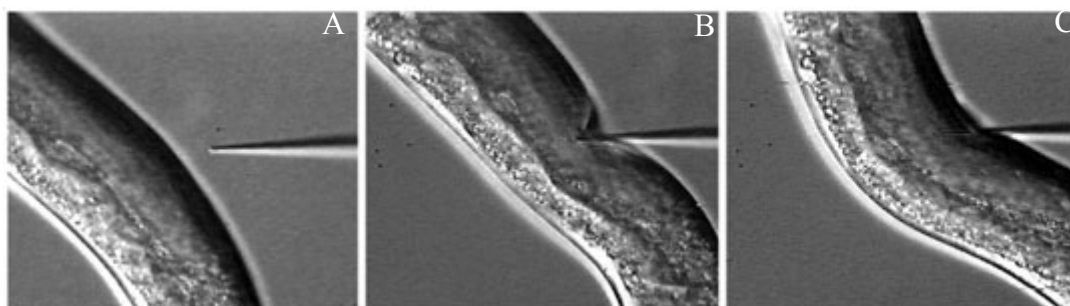

**Figure 2.2 Demonstration of micro-injection of DNA into the *C.elegans*.** **A** shows the needle in focal plane close to the gonad of a young adult hermaphrodite *C.elegans*. **B** shows how needle was inserted into the gonad of the worm using control X-Y of micromanipulator or worm was gently pushed against the needle tip until the gonad wall distends inward. **C** shows the insertion of needle into the worm by gently tapping side of the stage to cause the needle to puncture or pinch the gonad wall and the DNA solution was continuously injected into the gonad until it swelled up by touching the peddle with the feet. The needle was removed immediately and tested for the flow of DNA.

The worm was pushed against the needle tip until the cuticle distends inward and the stage was gently touched to pinch the cuticle. At this point, the needle was in the centre of the syncytial gonad, the pressure was then applied so that DNA solution moved freely in both directions throughout the gonad until the swelling of gonad was noticeable (Figure 2.2). The needle was

pulled off the worm and was tested for the flow of DNA solution and moved to the next worm to repeat the same step. A clogged needle was gently rubbed against the rough surface at the end of agar pad or otherwise the needle was replaced immediately. Worms were returned to the dissecting microscope and recovered with 5-10 $\mu$ l of standard M9 buffer. Once the worms started swimming in M9 buffer, a worm picker was used to transfer at least two worms per bacteria seeded plate and incubated at 20°C. After 1-2hrs, injected worms were examined for survival and the worms that failed to lay eggs and move around on the bacteria lawn were scored dead. More worms were injected if there was low survival after injection.

### **Section 2.7.3 Micro-injection of Black Widow Spider Venom (Combined latrotoxins)**

Worms were injected with combined latrotoxins to test its toxicity. The control experiment was set up by injecting potassium cyanide (KCN) into the worms. Purified combined latrotoxin was diluted in micro-injection buffer (20mM Tris at pH 8.0, 150mM NaCl) before injection. The injected worms were recovered in M9 buffer and transferred onto NGM bacteria seeded plates before incubation at 20°C for 3hrs. 20 worms were injected per point for individual genotype. After incubation, worms were scored for survival or lethality.

### **Section 2.7.4 Integration of transgene array in *C.elegans***

Transformation of *C.elegans* from micro-injection of transgenes exist in extrachromosomal array. This extrachromosomal array could be lost from the germ line after some times. Therefore, it is important to integrate the extrachromosomal array into the chromosome in order to have homozygous transgenic animals for characterization of transgene. The integration of transgene array in *C.elegans* was carried as follows; twenty transgenic animals per bacteria seeded plate at the L4 stage for each line were  $\gamma$ -irradiated for 5 minutes at 813 rad/mins [ $\gamma$ -irradiation dose; 4065 rad]. From each plate, 200 F<sub>1</sub> progeny supposedly carrying the array were picked and plated individually, and 4 F<sub>2</sub> progeny were picked from each F<sub>1</sub> plate and screened for 100% transmission of the array to F<sub>3</sub> progeny. Each integrated line gave rise to one homozygous strain with



100% transmission of array after self-fertilization of F<sub>3</sub> progeny. The strains created from integrated lines were bred against wild-type worms (N2 Bristol) five times to remove any unwanted mutation from background.

Dose calculation; 1Gy= 100 rad, central dose rate =8.13Gy/min, therefore 5 minutes  $\gamma$ -irradiation;  $100 \times 8.13 \times 5 = 4065$  rad. The standard dose is between 2000 and 4000 rad.

### Section 2.7.5 Staining *C.elegans* for $\beta$ -galactosidase expression

X-gal staining was carried out to detect the expression of  $\beta$ -galactosidase in transgenic animal carrying *gfp-lacZ* (nuclear localisation signal). Synchronised worms of different stages including embryos were washed off the culture plate with standard M9 buffer (section 2.6.1.2), and these worms were washed several times to remove excess bacteria. The worms were spun down

**Table 2.1 X-gal staining solution.**

Reagents	Volume added ( $\mu$ l)	Final concentration	Stock
distilled water	620		
PBS	250	1X	10X
MgCl <sub>2</sub>	1	1mM	1M
SDS	4	0.004%	1%
Redox buffer	100	10mM	100mM
Kanamycin	15	75 $\mu$ g/ml	5mg/ml
DAPI	2	2 $\mu$ g/ml	1mg/ml
X-gal (in dimethyl formamide)	8	0.04%	5%

Each reagent from individual stock was added in order for 1ml volume as described above. X-gal was added last to avoid precipitation. The freshly prepared X-gal staining solution can be kept for 2 days in aluminium foil. The following reagent stock; Redox buffer, Kanamycin, DAPI, and X-gal were kept at -20°C and the rest were kept at 4°C. Redox buffer: equal volumes 100mM potassium ferricyanide and potassium ferrocyanide were freshly from the stock each time they are being used. (caution:contains nasty toxic cyanide, wear gloves). 10XPBS ( NaCl 80g, KCl 2g, Na<sub>2</sub>HPO<sub>4</sub> 11.5g, KH<sub>2</sub>PO<sub>4</sub> 2g in distilled water, sterilized by autoclaving ).

in 1.5ml eppendorf tubes at 3000 rpm for 1minute and the supernatant was carefully aspirated. The tubes were frozen in liquid nitrogen or incubated at -80°C for 1hour. Tube's caps were opened and placed in a vacuum jar for 45mins for worms to lyophilize. After lyophilization, 250 $\mu$ l cold acetone was added to each tube and left in the freezer for 3mins. Acetone was care-

fully removed and allowed to air-dry for 2mins. Alternatively, fixation in 1-3% formaldehyde for 10mins at room temperature could replace lyophilization and acetone. Worm pellets were resuspended in ~200µl X-gal staining solution (Table 2.1) depending on the amount of worms and allowed to incubate at 37°C overnight. On the next day after the worms have been confirmed to be properly stained, worms were washed twice in 1xPBS. Stained worms were mounted on agar padded slides and examined under the microscope.

## **Section 2.8 Developmental and Behavioural assay in *C.elegans***

### **Section 2.8.1 Embryonic culture**

Embryos were studied for either lethality or survival during development. A gravid well-fed adult hermaphrodite was sliced open to release the eggs in a drop of water on a depression slide under the dissecting microscope using sterile razor needle. Eggs were carefully pipetted onto the middle of an agar pad and the worm picker was used to draw eggs as close as possible. A cover slip was gently placed on the eggs with aid of forcep. Vaseline was used to seal the cover slip across the edges and was studied for development on the inverted microscope at 20°C overnight or for a given number of hours by timing. Embryos were analysed for survival or lethality by counting.

### **Section 2.8.2 Larval culture**

Embryos were collected as described in section 2.8.1. Eggs were transferred into 9cm plates containing M9 buffer and incubated at 20°C overnight. On the next day, larval one (L1 stage) animals were aliquoted on NGM plate seeded with bacteria and scored. Embryos that failed to develop to L1 stage were scored dead. All the worms undergoing development were examined and scored until the adult stage.

### **Section 2.8.3 Measurement of brood size**

Brood size is the total number of offspring produced over a given period of a single adult hermaphrodite life time. Brood size measurements were all performed at 20°C. Brood sizes were

measured by plating an L4 hermaphrodite on bacteria seeded plate and transferred everyday until it stopped laying eggs. Total number of offspring were scored (ie; eggs laid) for each brood size of genotype. 10-20 animals were analysed for each genotype reported.

#### **Section 2.8.4 Defecation cycle**

Defecation is defined as the periodical activation of muscle contraction of *C.elegans*. This normally occurs every 45 seconds when the worm excretes gut contents. The defecation cycle was measured using motor program pBoc to pBoc (posterior body muscle contraction). An L4 hermaphrodite was placed on bacteria seeded plate a day prior to the study of defecation cycle and incubated at 20°C overnight. The following day, the young adult hermaphrodite was allowed to settle down for few minutes and studied for defecation cycle under stereo olympus microscope using 50X objective. The animal was closely watched and everytime a defecation cycle occurred the time was measured. 10-20 animals were studied for individual genotype.

#### **Section 2.8.5 Touch sensitivity**

Worms were examined for touch sensitivity after micro-injecting with toxic substances. Animals were stroked with worm picker by touching their heads and body. Ability to respond to the worm picker by moving around on the bacteria seeded plate meant animal was still alive and was scored. Failure to respond to worm picker and animal was not able to move around meant animal was dead and was scored. 20 animals were examined for touch sensitivity for each genotype.

### **Section 2.9 Protein methodologies**

#### **Section 2.9.1 Preparation of combined latrotoxin protein**

5mg was weighed from combined latrotoxins (BWSV) stock (100mg) and dissolved in 500µl micro-injection buffer (20mM Tris at pH8.0, 150mM NaCl). An eppendorf tube containing BWSV mixture was incubated on ice for 30mins. After incubation, the tube was spun down at 13000 rpm for 10 mins. The supernatant was removed into another eppendorf tube and spun

down at 13000rpm for 5 mins. After centrifugation, the supernatant was collected in another fresh tube and placed on ice. 250µl of supernatant was loaded onto the Sephacryl S-200 column for each run and fractions were collected at 0.5ml/min. Protein fraction concentration was determined using method by Bradford 1976.

### **Section 2.9.2 Bradford protein assay (Coomassie blue)**

Protein concentration was determined using Bradford assay method as described by Bradford in 1976. Bradford reagent made up of 100mg Coomassie Brilliant Blue G-125 was dissolved in 50ml 95% of ethanol and 100ml of 85% phosphoric acid was added. The solution was diluted to 1 litre when dye was completely dissolved and filtered through just before use. 4-20µl of assay samples were prepared and 1ml of Bradford reagent was added, then vortexed immediately. Absorbance was read at 590nm in an UV cuvette. A standard curve of bovine serum albumin (BSA) was generated between the range of 0-40µg/ml for determination of protein concentration. All assay samples including standards were done in triplicate and the means obtained were determined. The linear regression obtained from plot of BSA concentration against absorbance at 590nm for standard curve produced a linear plot and was used for sample reading to calculate protein sample concentration. Standard curve values with  $R^2 > 1$  were used.

### **Section 2.9.3 Lithium dodecyl sulphate-polyacrylamide gel electrophoresis (LDS-PAGE)**

The NuPAGE Novex Bis-Tris Gel system which provides the best separation and resolution of small to medium sized protein at low pH was used. The LDS-PAGE was performed using a NuPAGE Novex Bis-Tris kit. A NuPAGE gel was removed from its pouch and the gel cassette was rinsed with distilled water. The tape was peeled from the bottom of cassette and the comb was gently pulled from the cassette in one smooth motion. Sample wells were rinsed with 1X NuPAGE SDS running buffer ( 20X MES Running Buffer 50ml in 1litre of distilled water) by squirting with pipette. This process was repeated twice any inverting and shaking to remove the

buffer. Two gels were oriented in a Mini-Cell such that the notched well side of the cassette faces the inward towards the buffer core. The gels were seated on the bottom of Mini-Cell and were locked into place with gel tension wedge and plastic buffer dam was used for one running gel. The upper buffer chamber was filled with small amount of upper buffer chamber running buffer containing antioxidant (200 $\mu$ l of antioxidant in 200ml of 1X NuPAGE SDS running buffer) to check the tighness of the seal and was further filled until it exceeded level of well. 5-10 $\mu$ g of sample (13 $\mu$ l of sample protein, 5 $\mu$ l NuPAGE loading buffer, 2 $\mu$ l of NuPAGE reducing agent, mixed and boiled for 10 mins) were loaded alongside molecular weight marker. The lower chamber at the gap near the locking mechanism was filled with 600ml NuPAGE SDS running buffer and run at 200v for 30-60mins. Gels were removed after running by inserting the knife in between the plates and gently ripped the plates apart producing some cracking noise as the bond between the plate were broken. Plates were gently separated and gels were transfered for staining.

#### **Section 2.9.4    Coomassie blue gel staining**

Coomassie blue method was used to stain the gels. Staining of the gel was carried out for 30-60mins or overnight for better staining at room temperature with gentle shaking using Coomassie Blue stain (0.25g Coomassie blue R250, 90ml methanol:water (1:1), 10ml acetic acid and filtered prior to use). After 1hour or overnight staining, Coomassie blue was removed and washed with Coomassie destaining solution on the shaker (30% Methanol, 10% acetic acid (v/v)) until bands were clearly visible.

#### **Section 2.10    Experimental design of Plasmids**

Plasmids were designed to study various DNA fragments of lat-1 gene. DNA fragment of lat-1 gene or lat-1a cDNA was cloned into the pGEMT-Vector and sequenced to check no mutations had been generated by PCR procedure before further subcloning into the expression vector in

all the plasmids constructed. The first cloning into pGEMT-Vector was carried out due to the presence of compatible overhang for the PCR products that aids the digestion of restriction enzymes before subsequent cloning into the expression vector. All the plasmids constructed for the analysis of the *lat-1* gene or *lat-1a* cDNA and their respective markers are discussed below.

### Section 2.10.1 Construction of 5' end of *lat-1* promoter

To investigate in which cells the *lat-1* gene is expressed using *lacZ* reporter gene or *gfp* reporter gene, two different putative promoter regions of the *lat-1* gene were amplified using a high fidelity PCR system with B0457 cosmid (contains the full-sequence of the *lat-1* gene) as the template and the gene specific oligonucleotides as described in section 2.10.1.1 and 2.10.1.2 respectively.

#### Section 2.10.1.1 Creation of *lat-1::lacZ* constructs

Two different lengths of *lat-1* promoter of PCR products were obtained using the primers described in the Table 2.2. The first PCR product containing ~1.5kb of the 5' regulatory region of *lat-1* and four amino acid of exon 1 sequence of open reading frame was cloned into pGEMT-Vector. ~1.5kb fragment insert was excised with restriction enzymes BamHI and HindIII from pGEMT plasmid and subcloned into BamHI-HindIII sites of expression vector pPD96.04 (Nuclear localisation signal (NLS)-green fluorescent protein (GFP)-*lacZ* from Andrew Fire lab) to create [ $P_{1.5\text{kb } lat-1}::\text{Exon 1}(\text{lat-1})::\text{LacZ-gfp}$ ] plasmid designated as pAA411 (Figure 2.3A).

**Table 2.2 Oligonucleotides of *lat-1::lacZ* constructs.**

Name	Sequence 5' → 3'	Restriction sites	Description
LPH exon 5' (NLS)	AAGCTTCCCAGTCAATTTGGCA ACAGACGGTAATCATC	Hind III	5' end obtained from Hold-Dye paper with HindIII site on 10108-10130bp of B0457 cosmid ( <i>lat-1</i> gene) sequence
LPH exon 3' (NLS)	GGATCCTCACGTCGCATCAGTG CATACTATTTTGTTCGT	BamHI	3' end with BamHI site on 11580-11609bp of B0457cosmid ( <i>lat-1</i> gene) sequence
5' primer design	GGATCCTATTTCTGCCATACTG AAGGCGTGAGAAC	BamHI	5' end with BamHI site of 8612-8640bp B0457cosmid ( <i>lat-1</i> gene) sequence

**Table 2.2** Oligonucleotides of *lat-1::lacZ* constructs.

3' primer design	GGATCCCGTCGCATCAGTGCATA CTATTTTGTTCGTCGAGTGTA	BamHI	3' end with BamHI site on 11572-11609bp of B0457cosmid ( <i>lat-1</i> gene) sequence
------------------	--	-------	--

The second PCR product containing ~3kb of the 5' regulatory region of *lat-1* and three amino acid of exon 1 sequence of open reading frame was cloned into pGEMT-Vector. ~3kb fragment

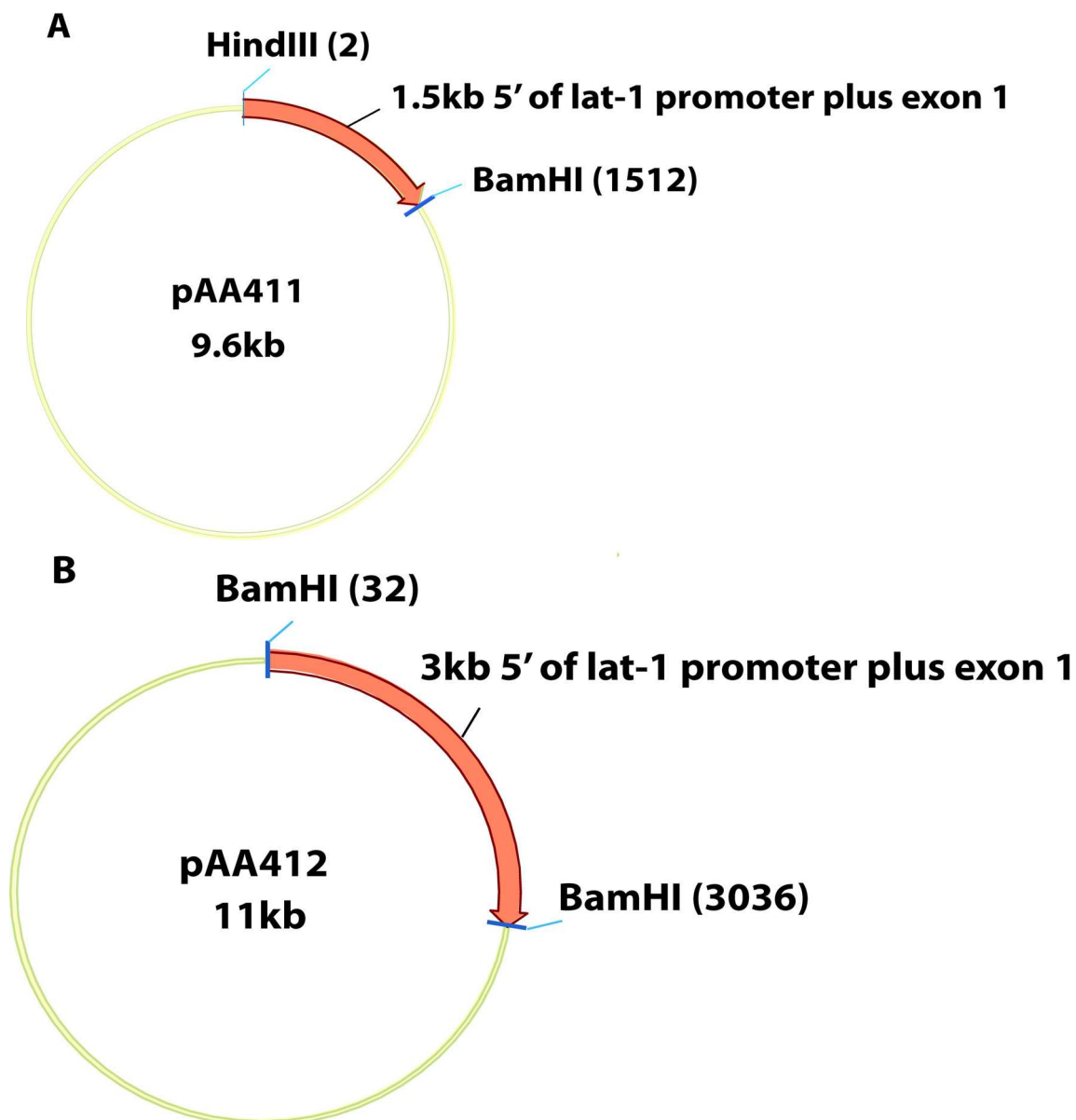
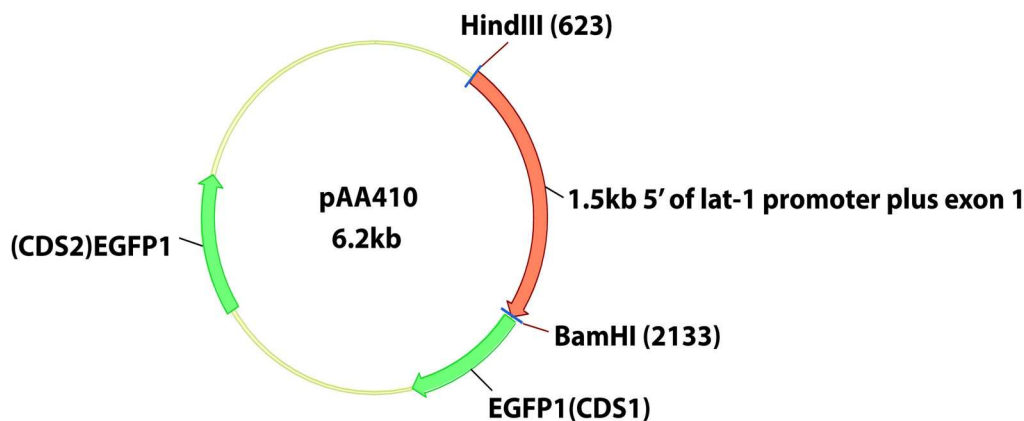

**Figure 2.3** The map of *lat-1::lacZ* constructs. **A** The map shows the transcriptional reporter fusion of ~1.5kb, 5' regulatory region of *lat-1* promoter with four amino acid of exon 1 sequence. Restriction enzymes; HindIII and BamHI show their restriction sites at 2 and 1512 position respectively upon fusion to pPD96.04 reporter gene (green fluorescent protein(*gfp*)-*lacZ*; nuclear localisation signal (NLS)). The resulting plasmid is designated as pAA411 with the size of 9.6kb. **B** The map shows the transcriptional reporter fusion of ~3kb, 5' regulatory region of *lat-1* promoter with three amino acid of exon 1 sequence. Restriction enzymes; BamHI and BamHI show their restriction sites at 32 and 3036 position respectively upon fusion to pPD96.04 reporter gene (green fluorescent protein(*gfp*)-*lacZ*; nuclear localisation signal (NLS)). The resulting plasmid is designated as pAA412 with size of 11kb.

insert was excised with restriction enzyme BamHI from pGEMT plasmid and subcloned into BamHI sites of expression vector pPD96.04 to create [P<sub>3kb lat-1</sub>::Exon 1(lat-1)::*LacZ-gfp*] plasmid designated as pAA412 (Figure 2.3B).

### Section 2.10.1.2 Creation of *lat-1::GFP* construct

To investigate comparison between expression pattern of *lat-1* fused to *gfp* reporter gene and *lat-1* fused to *lacZ* reporter gene, the *lat-1* promoter of PCR product was obtained using LPH exon 5' (NLS) and LPH exon 3' (NLS) primers as described in Table 2.2 above. The PCR product containing ~1.5kb of the 5' regulatory region of *lat-1* and four amino acid of exon 1 sequence of open reading frame was cloned into pGEMT-Vector. ~1.5kb fragment insert was subcloned into Hind III-BamHI sites of expression vector pEGFP-N1 to create [P<sub>1.5kb lat-1</sub>::Exon 1(lat-1)::*gfp*] plasmid designated as pAA410 (Figure 2.4).



**Figure 2.4** The map of *lat-1::GFP* construct. The map shows the transcriptional reporter fusion of ~1.5kb, 5' regulatory region of *lat-1* promoter with four amino acid of exon 1 sequence. Restriction enzymes; HindIII and BamHI show their restriction sites at 623 and 2133 position respectively upon fusion to pEGFP-N1 reporter gene (green fluorescent protein;*gfp*). with two coding sequences CDS 1&2 The resulting plasmid is designated as pAA410 with the size of 6.2kb

### Section 2.10.2 Construction of plasmids for the rescue of *lat-1(ok1465)* worms

To study the rescue of *lat-1* (*ok1465*) worms, plasmids were created using *lat-1a* cDNA reporter fusion. The construction of truncations of *lat-1a* cDNA are important to determine the functionality of various domains of *lat-1a* cDNA for the rescue of *lat-1(ok1465)* worms. To construct



the full-length lat-1a cDNA, C-terminal or N-terminal of lat-1a cDNA, the putative lat-1a cDNA was amplified using the high fidelity PCR system and gene specific oligonucleotides as described in section 2.10.2.1, 2.10.2.2 and 2.10.2.3 respectively.

### Section 2.10.2.1 Creation of full-length lat-1a cDNA construct

To create the full-length lat-1a cDNA construct, two different PCR products were obtained before further subcloning into expression vectors using primers described in Table. The first PCR product containing ~1.5kb of 5' regulatory region of lat-1 and intron between exon 1 and exon 2 of coding sequence was cloned into pGEMT-Vector resulting to pGEMT.lat-1 5', exon 1, 2 plasmid, and the primers used are LPH genomic 5' and LPH genomic 3'. The second PCR product containing lat-1a cDNA only was cloned into pGEMT-Vector resulting to pGEMT.lat-1a cDNA plasmid, and the primers used are LPH gene 5' and LPH gene 3'. The next approach was to make a full-length clone of lat-1a cDNA, with a reporter gene (GFP) fused to the C-terminus of the protein. To make a full-length lat-1a cDNA construct, pEGFP-N1 expression vector was excised with restriction enzymes XhoI and NotI and subcloned into XhoI and NotI restriction sites of pGEMT.lat-1a cDNA resulting to pGEMT.lat-1a cDNA.GFP plasmid. The pGEMT.lat-1a cDNA.GFP plasmid was excised with restriction enzymes AvrII and NotI and subcloned into AvrII and Not I restriction sites of [pGEMT.lat-1 5', exon 1, 2] plasmid resulting to [P<sub>1.5kb lat-1</sub>::FL(lat-1a cDNA)::*gfp*] plasmid designated as pAA401 (Figure 2.5)..

**Table 2.3 Oligonucleotides of full-length lat-1a cDNA construct.**

Name	Sequence 5' → 3'	Restriction sites	Description
LPH genomic 5'	GGTACCGGTTTCCCAGTCATTTGG CAACAGACG	KpnI	5' end with KpnI site on 10104-10130bp of B0457cosmid (lat-1 gene) sequence
LPH genomic 3'	AAGCTTAGGAAGGAAACAGCGAC AGAGAATCTTCC	HindIII	3' end with HindIII site on 14610-14639bp of B0457cosmid (lat-1 gene) sequence
LPH gene 5'	CACACAATATGTGATGGTGAAGCT GCT		5' end on 122-148bp of lat-1a cDNA sequence

**Table 2.3 Oligonucleotides of full-length lat-1a cDNA construct.**

LPH gene 3'	GGATCCCTCGAGTAAATCTTGACA ATACATGCTCGG	XhoI, BamHI	XhoI site engineered at 3043bp of lat-1a cDNA sequence for 3' end of full-length
-------------	--	-------------	--

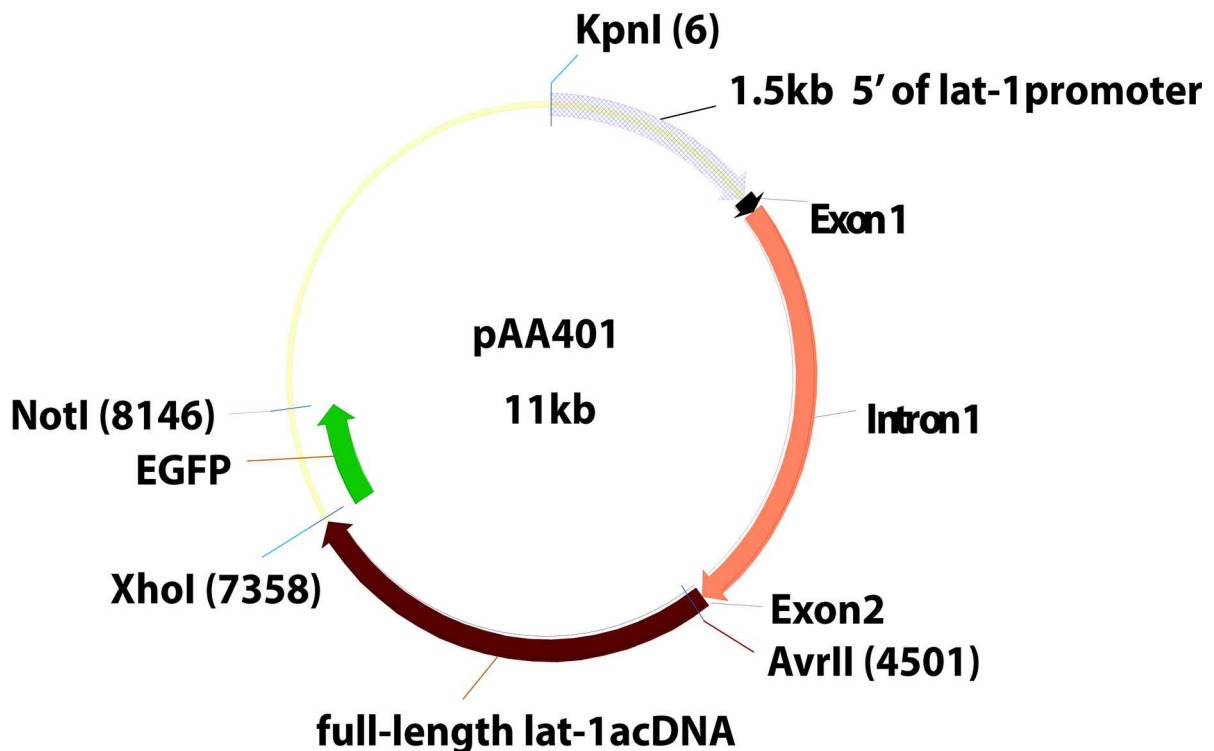

**Figure 2.5 The map of full-length lat-1a cDNA.** The map shows translational reporter fusion of full-length lat-1a cDNA to GFP under the control of ~1.5kb 5' regulatory region of lat-1 promoter with an intron between exon 1 and exon 2. The restriction sites are shown for the engineering of the fragments by the restriction enzymes. The resulting plasmid is designated as pAA401 with the size of 11kb.

### Section 2.10.2.2 Creation of C-terminal lat-1a cDNA construct

Truncation of C-terminal lat-1a cDNA resulted into three different constructs to determine their individual functionality. To create these constructs, three PCR products obtained were individually cloned into pGEMT-Vector before further subcloning into expression vectors. The first PCR product for the truncation of C-terminal of lat-1a cDNA to the area of four cysteine domain (4xCys) was cloned into pGEMT resulting to pGEMT.4xCys (lat-1a cDNA) plasmid, and the primers used are LPH gene 5' and 4xCys 3'. The second PCR product for the truncation of C-

terminal of lat-1a cDNA to the seven transmembrane domain (TM7) was cloned into pGEMT resulting to pGEMT.TM7(lat-1a cDNA) plasmid, and the primers used are LPH gene 5' and TM7 3'. The last PCR product for the truncation of C-terminal of lat-1a cDNA to the one transmembrane domain was cloned into pGEMT resulting into pGEMT.TM1(lat-1a cDNA) plasmid, and the primers used are LPH gene 5' and TM1 3'. The next step was to make a truncated clone of lat-1a cDNA, with a reporter gene (GFP) fused to C-terminus of the protein. To undertake this, pEGFP-N1 expression vector was excised with restriction enzymes XhoI and NotI and subcloned into XhoI and NotI restriction sites of [pGEMT.4xCys(lat-1a cDNA)] resulting to [pGEMT.4xCys(lat-1a cDNA).GFP] plasmid. The [pGEMT.4xCys(lat-1a cDNA).GFP] plasmid was excised with restriction enzymes AvrII and NotI and subcloned into AvrII and Not I restriction sites of pGEMT.lat-1 5', exon 1, 2 plasmid resulting to [P<sub>1.5kb lat-1</sub>::4xCys(lat-1a cDNA)::gfp] plasmid designated as pAA402 (Figure 2.6A). This same step was repeated for pGEMT.TM7(lat-1a cDNA) plasmid or pGEMT.TM1(lat-1a cDNA) plasmid by subcloning into AvrII and Not I restriction sites of pGEMT.lat-1 5', exon 1, 2 plasmid with resulting [P<sub>1.5kb lat-1</sub>::TM7(lat-1a cDNA)::gfp] plasmid designated as pAA403 (Figure 2.6B) or [P<sub>1.5kb lat-1</sub>::TM1(lat-1a cDNA)::gfp] plasmid designated as pAA407 (Figure 2.6C) respectively.

**Table 2.4 Oligonucleotides of C-terminal lat-1a cDNA construct.**

Name	Sequence 5' → 3'	Restriction sites	Description
LPH gene 5'	CACACAATATGTGATGGTGAAGCT GCT		the same 5' sequence used for all the truncations of C-terminal
4xCys 3'	CTCGAGCATTGATTAGGATGATTC ATTATTCCATT	XhoI	XhoI site engineered at 2622bp of lat-1a cDNA sequence for 3'end of 4xCys
TM7 3'	CTCGAGTTTACGCATTTTTTCAGC AAAGACGACGTGG	XhoI	XhoI site engineered at 2404 bp of lat-1a cDNA sequence for 3'end of TM7
TM1 3'	CTCGAGTCTGCTGAAAATCAAGTA GGCGAAGAAAGTG	XhoI	XhoI engineered at 1735bp of lat-1a cDNA sequence for 3' end of TM1

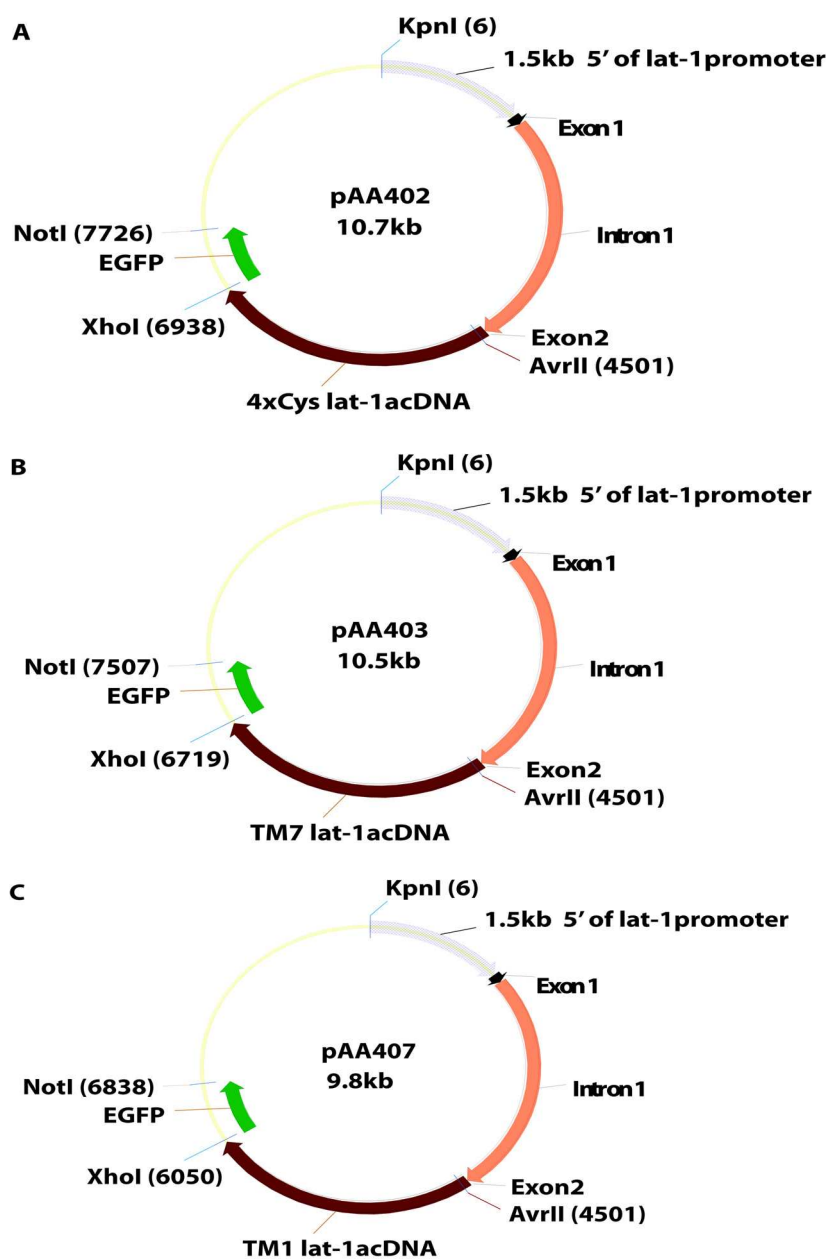

**Figure 2.6 The map of C-terminal lat-1a cDNA.** Each map shows translational reporter fusion of C-terminal truncation of lat-1a cDNA to GFP under the control of ~1.5kb 5' regulatory region of lat-1 promoter with an intron between exon 1 and exon 2. All the restriction sites are shown for the engineering of the fragments by the restriction enzymes. **A** shows the map of C-terminal truncation of lat-1a cDNA to the area four cysteine domain (4xCys) and the plasmid is designated as pAA402 with the size of 10.7kb. **B** shows the map of C-terminal truncation of lat-1a cDNA to the seven transmembrane domain (TM7) and the plasmid is designated as pAA403 with the size of 10.5kb. **C** shows the map of C-terminal truncation of lat-1a cDNA to one transmembrane domain (TM1) and the plasmid is designated as pAA407 with the size of 9.8kb.

### Section 2.10.2.3 Creation of N-terminal lat-1a cDNA construct

To determine the functionality of N-terminal lat-1a cDNA, three individual constructs were made. These constructs were created by individually cloning three different PCR products into pGEMT before further subcloning. The first PCR product for the truncation of N-terminal of lat-1a cDNA between 62-147 amino acid position is delta galactose-binding lectin domain ( $\Delta$ GBL) cloned into pGEMT with resultant product pGEMT. $\Delta$ GBL plasmid, using oligo lat-1N147 5' and oligo lat-1Nterdeletion 3' primers. The second PCR product for the truncation of N-terminal of lat-1a cDNA between 62-250 amino acid position is delta hormone receptor motif domain ( $\Delta$ HRM) cloned into pGEMT with resultant product pGEMT. $\Delta$ HRM plasmid, using oligo lat-1 N250 5' and oligo lat-1Nterdeletion 3' primers. The last PCR product for the truncation of N-terminal of lat-1a cDNA between 62-487 amino acid position is the rest of N-terminal domain ( $\Delta$ N) cloned into pGEMT with resultant product pGEMT. $\Delta$ N plasmid, using oligo lat-1 N487 5' and oligo lat-1Nterdeletion 3' primers. A further step was taken by cloning individual resultant pGEMT. $\Delta$ GBL, pGEMT. $\Delta$ HRM and pGEMT. $\Delta$ N plasmid into AvrII and HindIII restriction sites of [P<sub>1.5kb lat-1</sub>::FL(lat-1a cDNA)::*gfp*] plasmid (section 2.10.2.2) with resultant plasmids; [P<sub>1.5kb lat-1</sub>:: $\Delta$ GBL(lat-1a cDNA)::*gfp*] designated as pAA404 (Figure 2.7A), [P<sub>1.5kb lat-1</sub>:: $\Delta$ HRM(lat-1a cDNA)::*gfp*] designated as pAA405 (Figure 2.7B) and [P<sub>1.5kb lat-1</sub>:: $\Delta$ N(lat-1a cDNA)::*gfp*] designated as pAA408 (Figure 2.7C) respectively.

**Table 2.5** Oligonucleotides of N-terminal lat-1a cDNA construct.

Name	Sequence 5' → 3'	Restriction site	Description
Oligo lat-1N147 5'	GTCCTAGGATCAACTACT ACAACCGATAGCAGTTTG		3 amino acids (valine) added to 5' end on 439-465bp of lat-1a cDNA sequence for $\Delta$ GBL
Oligo lat-1N250 5'	GTCCTAGGAGTTATTTCTGA GTGAGGATGTCTCTGGA		3 amino acids (valine) added to 5' end on 748-774bp of lat-1a cDNA for $\Delta$ HRM
Oligo lat-1N487 5'	GTCCTAGGATCGTCAGTC CGTCATTTGAGCAATCCG		3 amino acids (valine) added to 5' end on 1459-1485bp of lat-1a cDNA for $\Delta$ N
Oligo lat-1Nterm deletion 3'	ACCGTCGACTGCAGAATT CGAAGCTTGAGC		3'end for all truncation of N-terminal on 7363-7391bp full-length construct sequence around HindIII site

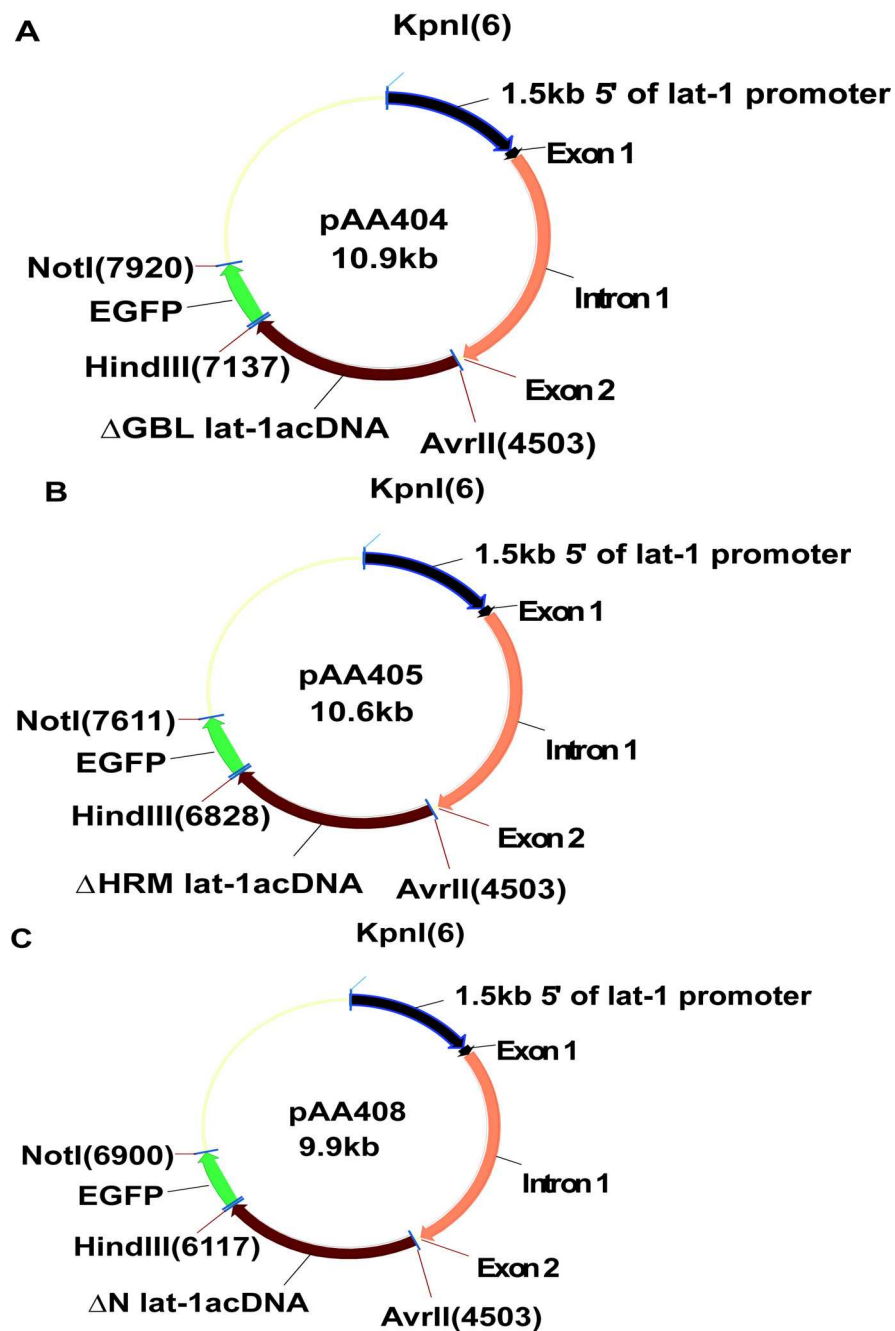

**Figure 2.7** The map of N-terminal lat-1a cDNA. Each map shows translational reporter fusion of N-terminal truncation of lat-1a cDNA to GFP under the control of ~1.5kb 5' regulatory region of lat-1 promoter with an intron between exon 1 and exon 2. All the restriction sites are shown for the engineering of the fragments by the restriction enzymes. **A** shows the map of truncation of N-terminal lat-1a cDNA for the galactose-binding lectin domain ( $\Delta$ GBL) and the plasmid is designated as pAA404 with the size of 10.9kb. **B** shows the map of truncation of N-terminal lat-1a cDNA for the hormone receptor motif domain ( $\Delta$ HRM) and the plasmid is designated as pAA405 with the size of 10.6kb. **C** shows the map of truncation of N-terminal lat-1a cDNA for the rest of N-terminal domain ( $\Delta$ N) and the plasmid is designated as pAA408 with the size of 9.9kb

### Section 2.10.3 Construction of *aex-3* plasmid

The *aex-3* plasmid is constructed for constitutive expression of *lat-1* in the nervous system. To create this construct, two different PCR products were cloned into pGEMT before further sub-cloning. The first PCR product containing ~1.3kb 5' regulatory region of *aex-3* gene was cloned into pGEMT resulting to pGEMT.*aex-3* plasmid using *aex-3* cosmid DNA as template and oligonucleotides Aex gene 5' and 3' as described in Table 2.6. The second PCR product containing exon 1 and exon 2 of B0457 cosmid (full sequence of *lat-1* gene) was cloned into pGEMT resulting to [pGEMT. exon 1, 2] plasmid using B0457 cosmid DNA as template and oligonucleotides *lat-1* 5' and *lat-1* genomic 3' as described in Table 2.6. Further step was taken by cloning pGEMT.exon 1, 2 plasmid into AvrII and Not I restriction sites of pGEMT.*lat-1a* cDNA plasmid resulting to pGEMT.*lat-1a* cDNA. exon 1, 2 plasmid. Lastly, the pGEMT.*lat-1a* cDNA.exon 1, 2 plasmid was cloned into BglII and NotI restriction sites of pGEMT.*aex-3* plasmid with resultant product [P<sub>1.3kb aex-3</sub>::FL(*lat-1a* cDNA)::*gfp*] plasmid designated as pAA409 (Figure 2.8)..

**Table 2.6 Oligonucleotides of *aex-3* constructs.**

Name	Sequence 5' → 3'	Restriction site	Description
Aex gene 5'	GGATCCACAAAACTGCCGCTT CAATTCTCCATG	BamHI	5' end with BamHI site on 28996-29015bp of <i>aex-3</i> cosmid sequence (complimentary)
Aex gene 3'	AGATCTATTCATTTTTATTAGGA TAGGTACATTGGTGC	BglII	3' end with BglII site on 27683-27714bp <i>aex-3</i> cosmid sequence (complimentary)
<i>lat-1</i> 5'	AGATCTCGACGTAACAAAACGA CTTATTCGTTGCTCC	BglII	5' end with BglII site on 11605-14639bp of B0457 cosmid ( <i>lat-1</i> gene) sequence
<i>lat-1</i> genomic 3'	AAGCTTAGGAAGGCAAACAGCG ACAGAGAATCTCC	HindIII	3'end with HindIII site on 14610-14639bp B0457 cosmid ( <i>lat-1</i> gene) sequence

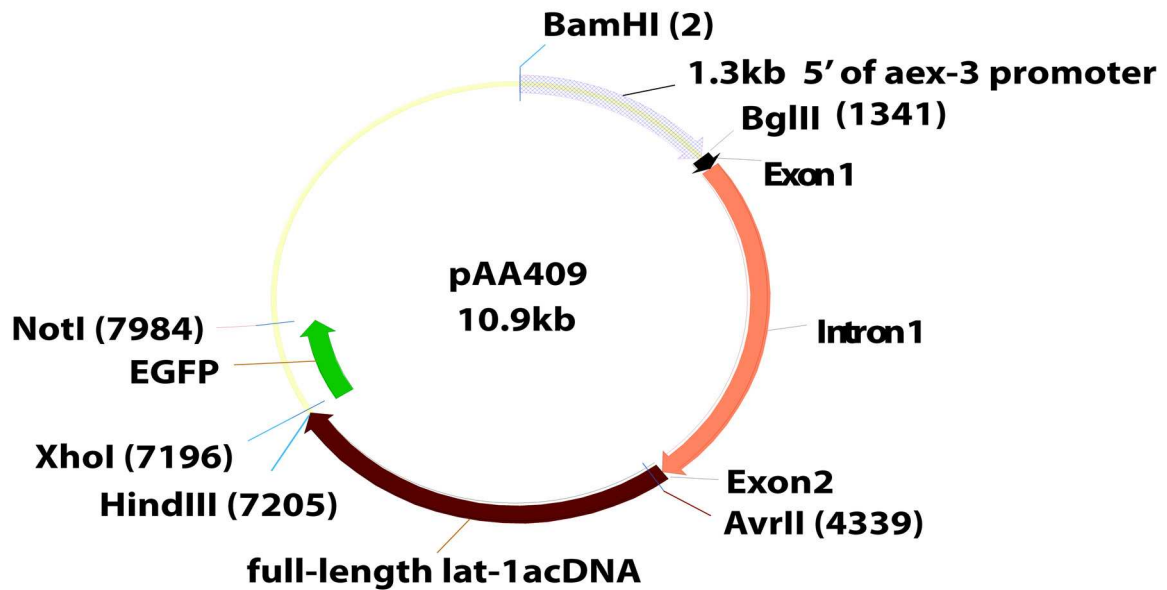

**Figure 2.8** The map of *aex-3* plasmid. The map shows translational reporter fusion of full-length *lat-1a* cDNA to GFP under the control of ~1.3kb 5' regulatory region of *aex-3* promoter with an intron between exon 1 and exon 2. The resulting plasmid is designated as pAA409 with size of 10.9kb and appropriate restriction sites are shown on the map.

#### Section 2.10.4 Construction of selectable markers

The selectable markers were constructed for the selection and identification of transgenic animals. The *unc-54::cfp* plasmid was a gift from Jody Winter, and is designated as pAA413 plasmid while *unc-54::mCherry* plasmid was constructed during this experiment. To create this plasmid, the PCR fragment was cloned into pGEMT before further subcloning into pPD30.38 (*unc-54* gene, body-wall muscle expression of the mCherry GFP) [Andrew Fire's lab]. The PCR product containing 700bp of mCherry was cloned into pGEMT resulting to pGEMT.mCherry plasmid using mcherry DNA as template and oligonucleotide 5' primer mcherry and 3' primer mCherry as described in Table 2.7. A further approach was taken by cloning pGEMT.mCherry plasmid into SacI restriction sites of pPD30.38 plasmid; this plasmid is *unc-54::mCherry* and the resulting plasmid designation is pAA414 (Figure 2.9).



**Table 2.7** Oligonucleotides of selectable marker *unc-54::mcherry*.

Name	Sequence 5' → 3'	Restriction site	Description
5' primer mcherry	GAGCTCATGGTGAGCAAGGGCG AGGAGGAT	SacI	5' end with SacI site on 1-24bp of mCherry sequence
3' primer mcherry	GAGCTCTTACTTGTACAGCTGCT CCATGCC	SacI	3' end with SacI site on 689-711bp of mCherry sequence

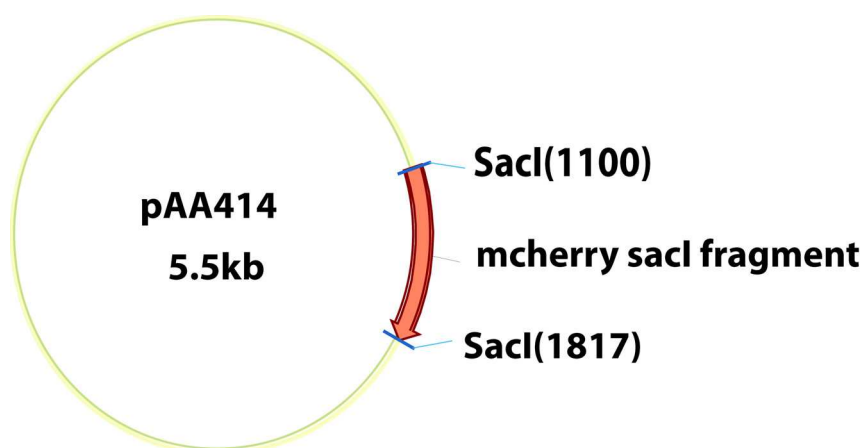

**Figure 2.9** The map of *unc-54::mcherry* plasmid. The map shows inframe fusion of mcherry to *unc-54* gene (pPD30.38). SacI restriction sites were used to introduce mcherry fragment to pPD30.38 plasmid. The resulting plasmid is designated as pAA414 with the size of 5.5kb

### Section 2.10.5 Statistical analysis

Statistical analysis using paired student's t-test with a confidence limit of 95% was carried out by Sigma Plot 10 spread sheet or Microsoft Excel spread sheet programs for two groups. To obtain LD<sub>50</sub>, dose response curve of combined latrotoxins effect was fitted using Graph Pad Prism 5.

### Section 2.10.6 Worm strains

All the constructs given in the Table 2.8 were made during the experiments with the exception of pRF4 plasmid (roller phenotype) and pEGFP (green fluorescent protein) provided as gifts. Transgenic strains were obtained from micro-injection of individual constructs with appropriate selectable markers as stated in the Table 2.8.

**Table 2.8 List of transgenic strains.**

Strain	Genotype	DNA	Marker
DA101-104	lat-1(ok1465) [P <sub>1.5kb lat-1</sub> ::FL(lat-1a cDNA):: <i>gfp</i> ; <i>unc-54::mCherry</i> ]	pAA401;pAA414	<i>unc-54::mCherry</i>
DA201-203	lat-1(ok1465) [P <sub>1.5kb lat-1</sub> ::4xCys(lat-1a cDNA):: <i>gfp</i> ; <i>unc-54::mCherry</i> ]	pAA402;pAA414	<i>unc-54::mCherry</i>
DA 301-303	lat-1(ok1465) [P <sub>1.5kb lat-1</sub> ::TM7(lat-1a cDNA):: <i>gfp</i> ; <i>unc-54::mCherry</i> ]	pAA403;pAA414	<i>unc-54::mCherry</i>
DA401-402	lat-1(ok1465) [P <sub>1.5kb lat-1</sub> ::ΔGBL(lat-1a cDNA):: <i>gfp</i> ; <i>unc-54::mCherry</i> ]	pAA404;pAA414	<i>unc-54::mCherry</i>
DA501	lat-1(ok1465) [P <sub>1.5kb lat-1</sub> ::ΔHRM(lat-1a cDNA):: <i>gfp</i> ; <i>unc-54::mCherry</i> ]	pAA405;pAA414	<i>unc-54::mCherry</i>
DA601-603	lat-1(ok1465)[B0457; <i>unc-54::cfp</i> ]	pAA406;pAA413	<i>unc-54::cfp</i>
DA701-703	N2 [P <sub>1.5kb lat-1</sub> ::FL(lat-1a cDNA):: <i>gfp</i> ; <i>unc-54::mCherry</i> ]	pAA401;pAA414	<i>unc-54::mCherry</i>
DA801-803	N2 [P <sub>1.5kb lat-1</sub> ::TM1(lat-1a cDNA):: <i>gfp</i> ; <i>unc-54::mCherry</i> ]	pAA407;pAA414	<i>unc-54::mCherry</i>
DA901-903	N2 [P <sub>1.5kb lat-1</sub> ::ΔN(lat-1a cDNA):: <i>gfp</i> ; <i>unc-54::mCherry</i> ]	pAA408;pAA414	<i>unc-54::mCherry</i>
DA111-113	N2 [P <sub>1.3kb aex-3</sub> ::FL(lat-1a cDNA):: <i>gfp</i> ; <i>unc-54::mCherry</i> ]	pAA409;pAA414	<i>unc-54::mCherry</i>
DA211-213	N2 [P <sub>1.5kb lat-1</sub> ::Exon1(lat-1):: <i>gfp</i> ; <i>unc-54-mCherry</i> ]	pAA410;pAA414	<i>unc-54::mCherry</i>
DA311-313	N2 [P <sub>1.5kb lat-1</sub> ::Exon1(lat-1):: <i>LacZ-gfp</i> ; <i>rol-6</i> ]	pAA411; pRF4	<i>rol-6(su1006)</i>
DA411-413	N2 [P <sub>3.0kb lat-1</sub> ::Exon1(lat-1):: <i>LacZ-gfp</i> ; <i>rol-6</i> ]	pAA412; pRF4	<i>rol-6(su1006)</i>
DA511-513	N2 [ <i>LacZ-gfp</i> ; <i>rol-6</i> ]	pPD96.04; pRF4	<i>rol-6(su1006)</i>
DA611-613	N2 [lat-1(GST):: <i>unc-54</i> ; <i>rol-6</i> ]	pAA411; pRF4	<i>rol-6(su1006)</i>
DA711-713	N2 [GST:: <i>unc-54</i> ; <i>rol-6</i> ]	pAA412; pRF4	<i>rol-6(su1006)</i>
DA811-813	N2 [ <i>unc-54::cfp</i> ]	pAA413	<i>unc-54::cfp</i>
DA911-913	N2 [ <i>unc-54::mCherry</i> ]	pAA414	<i>unc-54::mCherry</i>
DA920	N2[ <i>gfp</i> ; <i>unc-54::mCherry</i> ]	pEGFP;pAA414	<i>unc-54::mCherry</i>

## Chapter 3 Results

### Section 3.1 Optimisation of Microinjection

#### Section 3.1.1 Injection of Rhodamine-Dextran into *C.elegans*

Initial attempts to create transgenic *C.elegans* by micro-injection failed to yield transgenic offspring, although animals survived injection and manipulation (data not shown). Microinjection of fluorescently labelled Rhodamine-dextran (70,000 MW) was carried out, to investigate whether the injection into the syncytial arm of gonad of *C.elegans* was successful. When rhodamine-dextran was injected into the gonad, fluorescence was restricted to the arm of the gonad (Figure 3.1A). Injection of water yielded worms which showed negligible red fluorescence (Figure 3.1C), while injection of fluorescent dextran yielded a strong fluorescent signal (A, B).

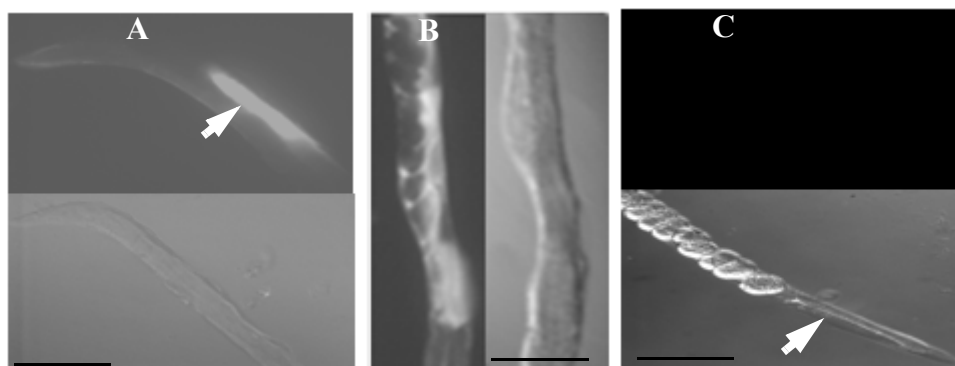

**Figure 3.1** Injection of rhodamine dextran into adult hermaphrodite. (A) Top, image of fluorescence using mCherry red-filter, of a worm which was injected in the gonad with rhodamine-dextran. The arrow indicates the position of the distal arm of the gonad in the adult hermaphrodite. Bottom image shows the same field taken under visible light, using DIC optics. (B) An adult hermaphrodite was injected with rhodamine-dextran in the body cavity. The left (mCherry fluorescence filter) image was taken under fluorescence, and under visible light which was slightly out of focus in the right panel. (C) Adult hermaphrodite was injected with water, and imaged with fluorescence (mCherry red-filter-top) and under visible light, with arrow indicating distal arm of gonad where water was injected. Scale bar; 50  $\mu\text{m}$ . All images were captured at 40x magnification.

The whole body of an adult hermaphrodite showed red fluorescence when the gonad was not

specifically targeted for injection (B). These data show that the red fluorescent signal is dependent upon injection of rhodamine-dextran, and is therefore the fluorescence from rhodamine itself. The microinjection into the gonad was accurate, and the injected fluid remained within the gonadal syncytium. This is held to be an important control for the technique for injecting *C. elegans* (J. Ahringer, personal communication). Subsequent to this experiment, it was noted that the room used for microinjection had high (>25°C) and variable temperature. Air conditioning was installed in this room, so that the temperature was controlled to 20°C. Subsequent experiments, therefore, benefited from temperature control.

### **Section 3.1.2 Effect of DNA Concentration on Transformation of *C.elegans***

The effect of DNA concentration was measured by injecting various DNA concentrations into wild-type *C.elegans*, to determine suitable DNA concentrations that would reproducibly form heritable extrachromosomal arrays (stable lines) in transgenic offspring. Plasmid pRF4 contains *rol-6 (su1006)*, conferring the roller phenotype [91] and plasmid pAA413 contains *unc-54::cfp* (body-wall muscle expression of the Cerulean CFP) [94] [95]; these were used as selectable markers, and were individually injected into wild-type *C.elegans*. The plasmids were injected over a concentration range from 12.5 to 800 µg/ml in this experiment, and the number of transformant rollers and fluorescent worms obtained per injection were compared at each concentration. Plasmid DNA at 800 µg/ml produced the highest number of stable transgenic animals, 29% and 73% respectively (Table 3.1). As the concentration of injected DNA decreased, the number of stable transgenic animals decreased (Table 3.1). The ability of an inherited transgene to transmit beyond the F<sub>2</sub> generation is an indication that a stable line has been formed, and the percentage of stable transgenic lines with either transformant roller or fluorescent worm is shown (Table 3.1).

**Table 3.1** Effect of DNA concentration on transgenesis.

DNA( $\mu\text{g/ml}$ )	No of worms injected	No of progeny per $F_1$	No of transgenic $F_1$	No of stable line (S)	% of stability S/ $F_1$
<i>pRF4</i>					
800	16	294 $\pm$ 5	24	7	29%
400	10	296 $\pm$ 4	20	5	25%
200	20	292 $\pm$ 2	17	3	18%
50	18	301 $\pm$ 27	14	2	14%
12.5	20	294 $\pm$ 7	6	0	0%
<i>unc-54::cfp</i> (CFP)					
800	19	300 $\pm$ 6	33	24	73%
400	14	295 $\pm$ 13	25	17	68%
200	17	287 $\pm$ 8	20	13	65%
50	25	282 $\pm$ 5	15	7	47%
12.5	23	288 $\pm$ 10	8	1	13%

The concentration of pRF4, or CFP injected was between 12.5-800  $\mu\text{g/ml}$ .  $F_1$  generation has the total number of progeny including transformants (Mean $\pm$  Standard Deviation). The number of offspring with consistent transmission of the array from an individual line is regarded as a stable line either for the transgenic roller or fluorescent worm. Percentage of stability was calculated by dividing stable line S over transgenic  $F_1$ . A stable line is a line that transmits a transgene beyond the  $F_2$  generation.

The stable lines obtained from injection of both pRF4 and CFP account for 13%-73% of offspring, and where tested, the transgene inherits in a non-Mendelian segregation pattern (data not shown). This result showed that the DNA concentration determined the number of transgenic animals. Therefore, DNA concentration is an important factor for *C.elegans* transformation success.

## Section 3.2 Structure of lat-1 ok1465 allele

### Section 3.2.1 Deletion of lat-1 allele

The ok1465 allele of the lat-1 gene was provided as a worm strain VC965 by the *C.elegans* Gene Knockout Consortium. The deletion breakpoint for the ok1465 allele is between bases 18185 and 20395 of the B0457 cosmid sequence. Three different transcripts (B0457.1a, B0457.1b, B0457.1c) are produced from lat-1 gene with only two transcripts ('a' 'b') yielding putatively functional protein coding sequences, as a result of differential splicing of third exon (see [www.wormbase.org](http://www.wormbase.org)). In the lat-1(ok1465) allele, these two transcripts will give rise to dysfunctional variants. The lat-1a transcript (B0457.1a) has a deletion from exon 3a-5, resulting in the direct splicing of exon 2 and exon 6. This yields a transcript which is in frame, thus producing a protein of 531 amino acids. The lat-1b transcript (B0457.1b) has a deletion in the middle of exon 3b, which is then fused to intron sequence, and would therefore be expected to yield a truncated protein of 371 amino acids. The structure of the wild-type lat-1a has five conserved domains, with sizeable extracellular domains containing a galactose-binding lectin domain, a hormone receptor motif domain (HRM), and a G-protein coupled receptor proteolysis site (GPS). The transmembrane domain is typical of the secretin/class II family of G Protein Coupled Receptors (GPCRs). The intracellular domain is also relatively large, but the only identifiable domain structure is an area containing a four cysteine motif (4xCys). Figure 3.2 shows the structure of the protein arising from the lat-1(ok1465) deletion for the lat-1a transcript, where amino acids 100-583 of the protein were deleted. As well as a substantial region of the extracellular domain, the first transmembrane helix of the 7-transmembrane domain has been deleted, and therefore it will be expected to yield a non-functional protein.

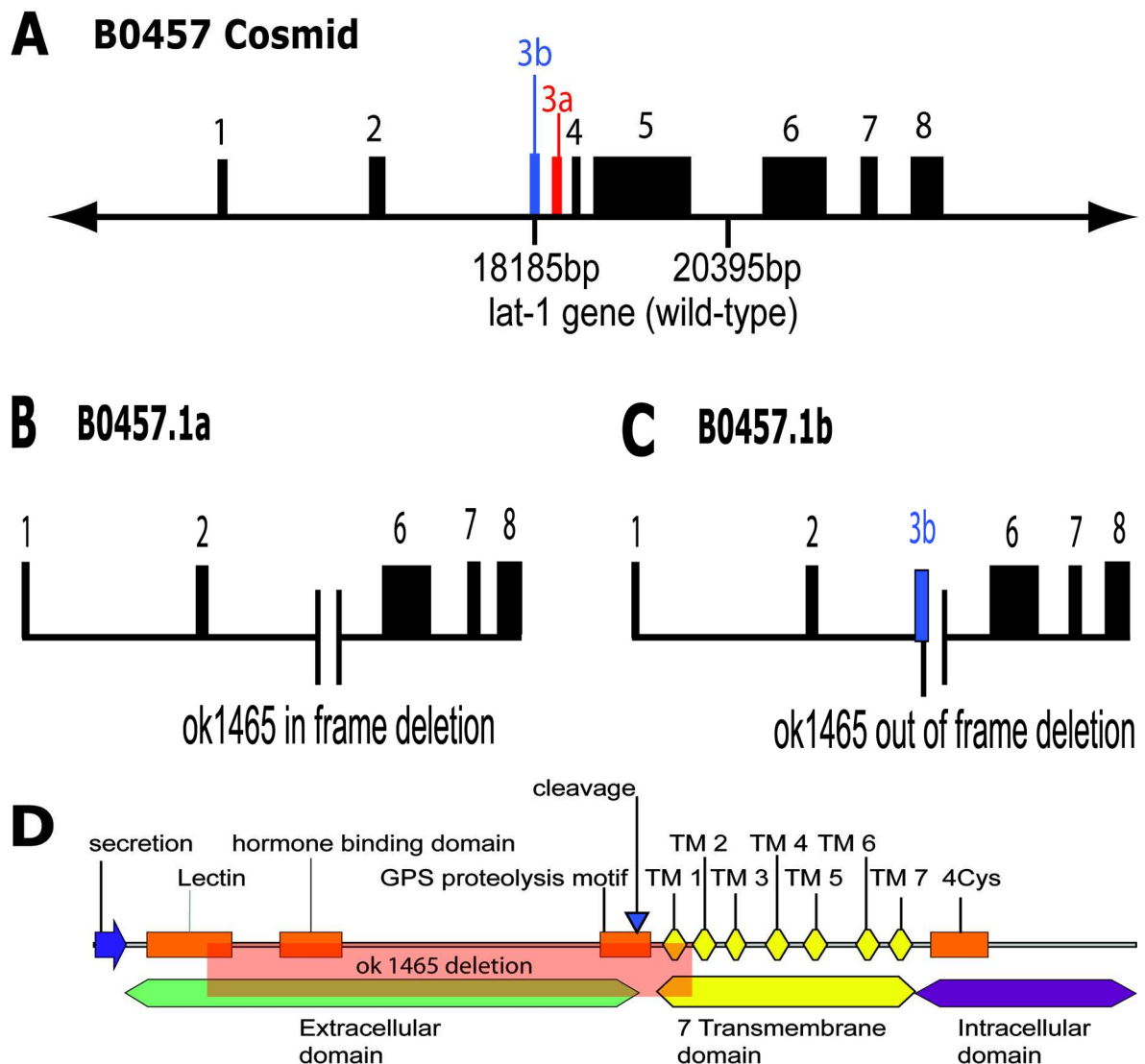

**Figure 3.2 The ok1465 *lat-1* allele.** **A** The top picture shows a cartoon of the *lat-1* gene (wild-type) in the B0457 cosmid, *lat-1* ok1465 allele deletion spans nucleotides 18185-20395 between exon 3b and exon 5. Exons 1-8 of *lat-1* gene (wild-type) are depicted in black boxes apart from 3a and 3b which are depicted in red and blue respectively, introns are indicated as black lines. **B**, **C** The middle pictures show cartoons of the *lat-1* ok1465 gene. **B** The splice variant of *lat-1* ok1465 (B0457.1a) that shows in-frame deletion of exons 3-5, skipping 3b due to alternative splicing. **C** shows the splice variant of *lat-1* ok1465 (B0457.1b) which has an out of frame deletion in the middle of exon 3b and finishes in the intron before exon 6. **D** The bottom picture is the predicted *lat-1a* protein. The picture shows putative domains of the *lat-1* protein, including the secretion region (a blue arrow), the galactose-binding lection domain (Lectin), the “hormone receptor motif domain” (hormone binding domain), the G-protein coupled receptor proteolysis site (GPS proteolysis motif, with the site of cleavage indicated by a blue triangle), the transmembrane domain receptors (TM1, TM2, TM3, TM4, TM5, TM6, TM7), the area of four cysteine domain (4xCys). The position of the amino acids deleted in the ok1465 deletion is shown by a light pink box marked “ok1465 deletion”. The extracellular domains are highlighted in green colour, The seven transmembrane domains is shown in yellow colour, and the intracellular domains are C-terminal, in purple colour.

### Section 3.2.2 Phenotype of lat-1 ok1465 allele

The ok1465 allele was balanced by mIn1[dpy-10(dpy), mIs 14 (gfp)] ([96]), to maintain the allele as the stable heterozygote, mIn1/lat-1- which has the wild-type phenotype, is selectable by the GFP marker, and the lethality of the lat-1 homozygotes is balanced by the poor fecundity and phenotype of the dumpy mIn1 homozygotes. ok1465 wild-type and deletion alleles were confirmed by PCR, using internal and external primer sequence (DRB personal communication). The mIn1/lat-1 worm was only outcrossed once after mutagenesis by *C.elegans* Gene knockout Consortium, and the lat-1 allele was outcrossed five times against N2 worms (DRB, unpublished) prior to use in this thesis. In order to characterise whether the lat-1(ok1465) allele had an adverse effect, the number of offspring from the mIn1/lat-1(ok1465) worms was determined.

**Table 3.2 Measurement of offspring survival.**

Genotype	% embryonic lethality (n=10)	% larval lethality (n=10)	% survival to adulthood (n=10)
lat-1(ok1465)	33% (68/208)	65% (136/208)	2% (4/208)
Wild-type	0% (0/285)	0% (0/285)	100% (285/285)

Offspring from lat-1 (ok1465) allele hermaphrodites were measured for the survival during development. Embryos were dissected from N2 or lat-1(ok1465) hermaphrodites (n=10), and incubated on an agar pad in water overnight at 20°C (section 2.8.1); images of development were acquired at 5 minute intervals for 24 hours. The resulting movie was reviewed to count the number of embryos that died prior to L1 stage (% embryo lethality). From 208 embryos of lat-1 null animals counted, 68 embryos died at pre-coma stage (33%), whereas in wild-type, no death was recorded out of 285 embryos counted (0%). Embryos were also dissected from N2 or lat-1 (ok1465) allele hermaphrodites for larvae survival and placed in the plates with M9 buffer, incubated at 20°C overnight and transferred to bacteria seeded plates for count (section 2.8.2). Out of 208 larva of lat-1 (ok1465) animals counted, 136 larva died by larvae 2 stage (65%), and no death was recorded from 285 larva of wild-type counted (0%). Only ~4 adult hermaphrodites survived from 208 embryos counted (2%) for lat-1 (ok1465) animal, whereas in wild-type 285 embryos produced 285 surviving adults (100%). n is the number of animals analysed.

Individual mIn1/lat-1 animals were singly plated, and allowed to self-fertilise, moving the animals on to a fresh plate every day. At three days after laying, the offspring (at L4/ adult stage)



were counted, giving 1677 mIn1/mIn1 (*i.e.* dumpy phenotype and showing green fluorescence), 3540 mIn1/lat-1 (*i.e.* wild-type appearance, and showing green fluorescence), and 32 lat-1/lat-1 (no green fluorescence) offspring. This number of offspring shows a significant deviation from the 1:2:1 ratio expected from mendelian genetics ( $\chi^2$ - test,  $P < 0.05$ ). However, there was no significant difference when comparing between expected ratio of 25% (mIn1/mIn1): 50% (mIn1/lat-1) and the observed numbers of 1677 (mIn1/mIn1): 3540 (mIn1/lat-1) ( $\chi^2$ - test,  $P > 0.05$ ). However, the ratio observed for lat-1/lat-1 (0.6%) is significantly different from the expected ratio of 25% ( $\chi^2$ - test,  $P < 0.05$ ). Therefore, this data shows that the lat-1/lat-1 are significantly under-represented, possibly due to the genotype causing a developmental defect or lethality.

There were only ~2-5% of the expected number of lat-1 null adult homozygous offspring, but these were from heterozygous parents; it was not clear if the wild-type parent was providing function to the offspring which affects its survival. To investigate whether there is a maternal effect, the lethality of lat-1(ok1465) must also be determined in homozygous animals. To determine the number of viable, adult offspring from homozygous lat-1(ok1465) worms, single L4 hermaphrodites of lat-1 null were self-fertilised and transferred everyday until egg-laying stopped. The number of offspring for each individual plated animal was counted, and each animal produced only ~4 surviving adult offspring; 2% (4/208) ( $n=10$ ) with embryonic and larva lethality. The proportion of surviving adults that are lat-1(ok1465) homozygous are similar whether the parent is heterozygous, or homozygous; and this finding excludes the possibility that this is a maternal effect gene.

Offspring were examined to determine the stages during which the lethality occurred for the lat-1(ok1465) animals. Embryos were dissected from lat-1(ok1465) adult hermaphrodites, and

wild-type hermaphrodites as a negative control, to study embryonic and larval lethality, and survival to adulthood. The results showed that *lat-1(ok1465)* worm had 33% (68/208) (n=10) embryonic lethality, and 65% (136/208) (n=10) larval lethality, whereas analysis of wild-type offspring yielded 0% (0/285) embryo (n=10) or 0% (0/285) (n=10) larval lethality with 100% (285/285) (n=10) survival to adulthood (Table 3.2). The phenotype of *lat-1(ok1465)* animal offspring is characterised by a variety of failures of epithelial migration and failure of gut attachment to pharynx in the larvae. A typical example of embryonic or larval death in *lat-1* homozygous animals is shown in Figure 3.3. Thus, this result demonstrates that 33% and 65% lethality occurred throughout the stages of embryo and larval development, respectively.

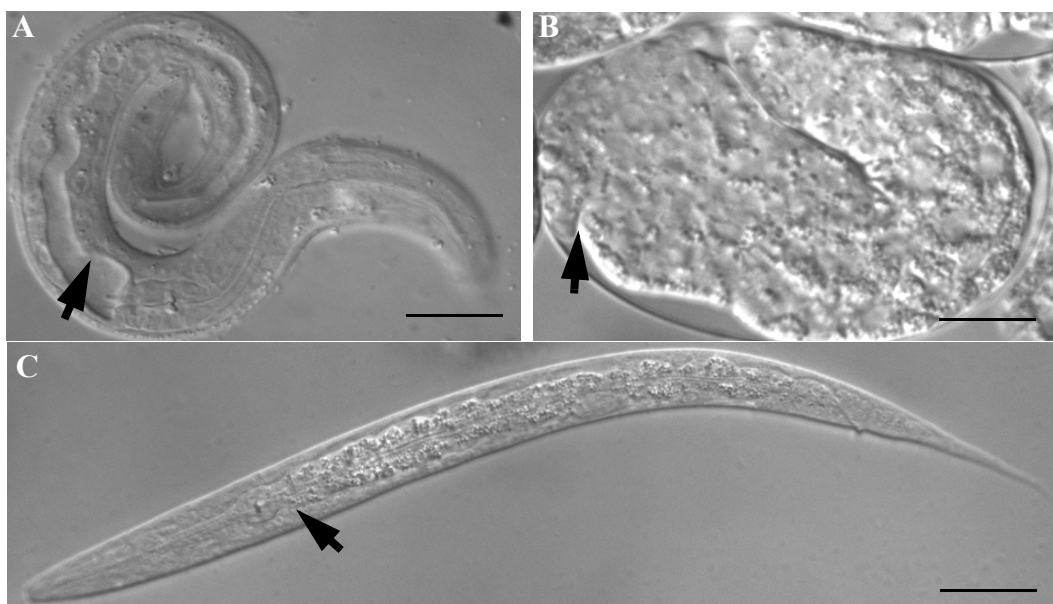

**Figure 3.3** Phenotypes of *lat-1(ok1465)* worms and wild-type (N2 Bristol). Embryo from *lat-1* worms were allowed to develop at 20°C after harvesting, then viewed under DIC optics (A) is a typical example of *lat-1* worm arrested larva with gut detached from pharynx as indicated by arrow. (B) is a typical example of a *lat-1* worm embryo. The arrow points to a rupture, with cells extruding from the head during the elongation stage. (C) is a typical example of wild-type L1 with gut attached to pharynx. The scale bar is shown as a thin black line, and represents 50 μm.

This is consistent with the bioinformatic analysis that suggests that the function of the *lat-1* gene will be lost in the *ok1465* allele. However, these data do not exclude the possibility that the phenotype of *lat-1(ok1465)* worms could arise from a mutation in a closely linked gene; given that

the ok1465 allele has only been outcrossed six times, this could be a considerable portion of the genome, and closely linked (and potentially mutated) genes would be likely to remain linked to the lat-1 allele.

### Section 3.3 Expression pattern under the lat-1 gene promoter

The aim was to study the expression pattern of the lat-1 gene promoter during developmental and adult stages, and thus to determine in which cells the lat-1 gene is expressed. Therefore, two different regions of the 5' end of the lat-1 gene, putatively including the promoter sequences, were fused to either a *lacZ* reporter gene (encoding a nuclear localization signal) or to a *gfp* reporter gene. Transgenic animals were created with the resulting constructs, and the expression patterns of *lacZ* or *gfp* determined.

#### Section 3.3.1 Generation of *lat-1::LacZ* transgenic animals

Two different lengths of the lat-1 promoter were fused to a *lacZ* reporter gene as described in Figure 3.4. The first lat-1 promoter contains ~1.5kb of the 5' regulatory region of lat-1, and a minimal region of exon 1. The exon 1 sequence contains four amino acids of the open reading frame, which was fused in-frame to the reporter gene *lacZ-gfp* from plasmid pPD96.04 (<http://www.ciwemb.edu>; [97]; this plasmid is the 1.5kb lat-1 construct, [P<sub>1.5kb lat-1</sub>::Exon1(lat-1)::LacZ-gfp]), and the resulting plasmid designation is pAA411. The second lat-1 promoter contains ~3kb of the 5' regulatory region of lat-1, also contains a minimal region of exon 1 with three amino acids which was fused in-frame to reporter gene *lacZ-gfp* to give plasmid ~3kb lat-1 construct, [P<sub>3.0kb lat-1</sub>::Exon1(lat-1)::LacZ-gfp] and designation pAA412. These two lat-1 promoters were compared to find out if there was any difference in terms of expression patterns.

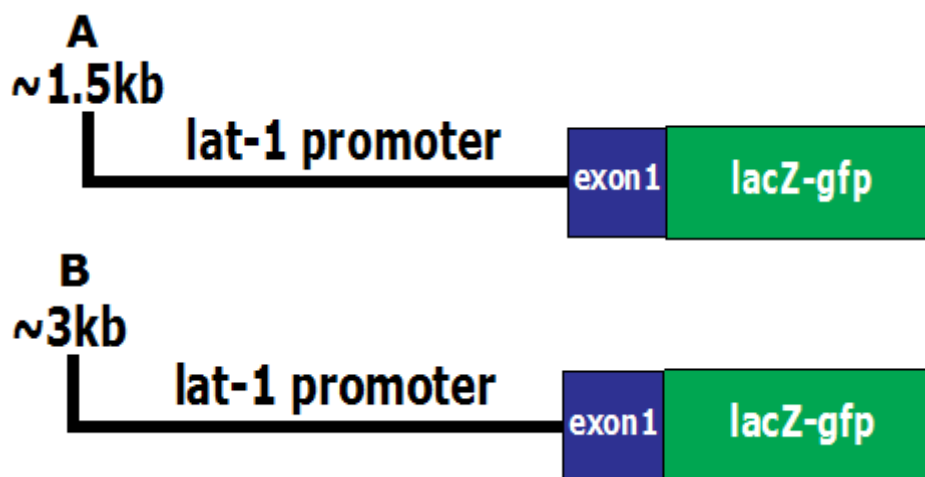

**Figure 3.4** Transcriptional fusions of *lat-1* gene promoter to *lacZ-gfp*. **A)** The cartoon shows an in-frame transcriptional fusion of *lat-1* gene, with ~1.5kb *lat-1* promoter (5' regulatory region) including a minimal region of exon 1 with four amino acids, which was then fused to reporter gene; green fluorescent protein (*gfp*) with nuclear localisation signal and  $\beta$ -galactosidase (*lacZ*). The resulting plasmid from this fusion is [P<sub>1.5kb lat-1</sub>::Exon1(*lat-1*)::*LacZ-gfp*] designated as [pAA411] (see section 2.7.1). **B)** The cartoon shows in-frame transcriptional fusion of *lat-1* gene. ~3kb *lat-1* promoter (5' regulatory region) was fused to a minimal region of exon 1 with three amino acids, which was then fused to a reporter gene encoding green fluorescent protein (*gfp*) with nuclear localisation signal and  $\beta$ -galactosidase (*lacZ*), resulting in the plasmid [P<sub>3kb lat-1</sub>::Exon1(*lat-1*)::*LacZ-gfp*] designated as [pAA412] (see section 2.10.1).

The ~1.5kb *lat-1* construct or ~3kb *lat-1* construct were co-injected with *rol-6(su1006)* [pRF4], as a selectable marker into wild-type worms, while in the negative control the *lacZ* reporter plasmid, without an insert, [pPD96.04] was co-injected with pRF4 into wild-type worms. Transgenic animals generated were identified by the roller phenotype, and none of these transgenic animals showed green fluorescence when using appropriate GFP filters. Three independent stable lines were obtained from these different injected F<sub>0</sub> animals for each combination of plasmids.

Stable lines were obtained from injection of the ~1.5kb and ~3kb *lat-1* constructs for 13%-33% and 13%-26% respectively of the transgenic F<sub>1</sub>, while the negative control *LacZ-gfp* gave stable lines from 7%-16% of transgenic F<sub>1</sub> (Table 3.3).

**Table 3.3 Characterisation of *lat-1* reporter and pRF4 transgenesis.**

DNA injected	No of transgenic (F <sub>1</sub> )	No of stable line (S)	% stability (S/F <sub>1</sub> )
[P <sub>1.5kb lat-1</sub> ::Exon1(lat-1):: <i>LacZ-gfp;rol-6</i> ][pAA411;pRF4]	18	4	22%
	24	8	33%
	15	2	13%
[P <sub>3.0kb lat-1</sub> ::Exon1(lat-1):: <i>LacZ-gfp;rol-6</i> ] [pAA412;pRF4]	23	6	26%
	16	2	13%
	19	4	21%
[ <i>LacZ-gfp;rol-6</i> ][pPD96.04;pRF4]	19	3	16%
	17	2	12%
	15	1	7%

The plasmid DNA of ~1.5kb *lat-1* construct, ~3kb *lat-1* construct, or *gfp-lacZ* with *rol-6(su1006)* at concentration of 50-100µg/ml. Transgenic animals were identified at L3 stage by the roller phenotype. The number of transgenic( F<sub>1</sub>), and stable line (S) from each injected animal is shown; a stable line is defined as a line where the roller phenotype propagates through three generations. Percentage stability (%) is the number of stable lines, divided by number of transgenic (F<sub>1</sub>) from each injected animal.

### Section 3.3.2 Generation of *lat-1::GFP* transgenic animals

In order to follow the expression pattern of *lat-1* gene during development, the *lat-1* promoter (~1.5kb, 5' regulatory region of *lat-1*) which contains minimal region of exon 1 with four amino acids was transcriptionally fused in-frame to the reporter gene *gfp*; this plasmid is ~1.5kb *gfp* construct [P<sub>1.5kb lat-1</sub>::Exon1(lat-1)::*gfp*] [pAA410]. Figure 3.5 shows a schematic of the transcriptional *gfp* fusion with the *lat-1* gene promoter.

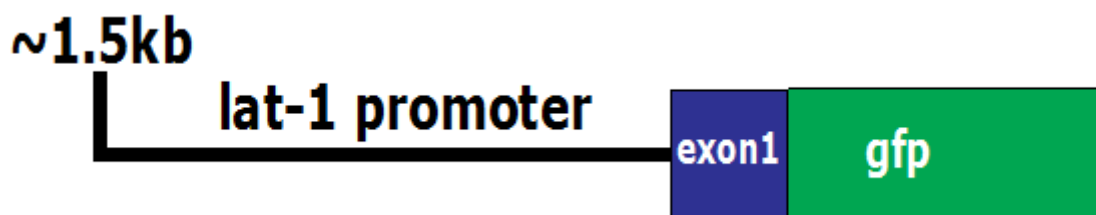

**Figure 3.5** Transcriptional *gfp* fusion with the *lat-1* gene promoter. The cartoon shows an in-frame transcriptional fusion of *lat-1* gene with ~1.5kb *lat-1* promoter (5' regulatory region) that includes a minimal region of exon 1 with four amino acids, which was then fused to a reporter gene encoding green fluorescent protein (*gfp*), that leads to a resulting plasmid [P<sub>1.5kb lat-1</sub>::Exon1(*lat-1*)::*gfp*] designated as [pAA410] (see section 2.10.1).

The reporter fusion ~1.5kb *gfp* construct was co-injected with mCherry (*unc-54::mCherry* designated as pAA414, the body-wall muscle expression of mCherry GFP) as a selectable marker into wild-type (N2 Bristol) worms, while plasmid pEGFP-N1, containing the GFP construct without a relevant promoter as a negative control, was co-injected with mCherry (a positive control for transgenesis) into wild-type worms. Transgenic animals obtained were identified by red fluorescent body-wall muscle, and the negative control only showed red fluorescence in body-

**Table 3.4** Characterisation of *lat-1* reporter and *unc-54::mCherry* .

DNA injected	No of transgenic F <sub>1</sub>	No of stable line (S)	% stability (S/F <sub>1</sub> )
[P <sub>1.5kb lat-1</sub> ::Exon1( <i>lat-1</i> ):: <i>gfp</i> ; <i>unc-54::mCherry</i> ] [pAA410;pAA414].	27	9	33%
	21	3	14%
	17	3	18%
[ <i>gfp</i> ; <i>unc-54::mCherry</i> ] [pEGFP;pAA414]	23	5	22%
	14	2	14%
	10	0	0%

The plasmid DNA of ~1.5kb *gfp* construct or GFP plasmid with mCherry was injected into the syncytial gonad of wild-type worms at the concentration of 50-100µg/ml. Transgenic animals were identified by red fluorescent body-wall muscle using mCherry red filter. The number of transgenic (F<sub>1</sub>), and stable line (s) from each injected animal is shown; a stable line is defined as a line where selectable marker mCherry transgene propagates through three generations . Percentage stability (%) is the number of stable lines divided by number of transgenic (F<sub>1</sub>) from each injected animal.

wall muscle, with no green fluorescence. At least 2-3 independent stable lines were generated

from three different injected F<sub>0</sub> animals for each plasmid combination..

Transgenic stable lines obtained from injection of ~1.5kb *gfp* construct account for 14%-33% of the transgenic F<sub>1</sub>, while the negative control GFP plasmid account for 14%-16% of the transgenic F<sub>1</sub> (Table 3.4).

### Section 3.3.2.1 Integration of extrachromosomal arrays by $\gamma$ -irradiation

All the transgenic animals obtained from micro-injection of either ~1.5kb *lat-1* construct and ~3kb *lat-1* construct and ~1.5kb *gfp* construct including negative controls are said to be stable as they transmit the transgene beyond the F<sub>2</sub> generation, presumably as an extrachromosomal array. However, it is important to characterise lines which have a stably integrated chromosomal copy of the transgene, as this will give more consistent transmission in homozygous animals, and also may lead to more consistent expression. At least one line each from all the three lines generated from injection of individual construct was  $\gamma$ -irradiated (section 2.7.4). The strains cre-

**Table 3.5 Integration of *LacZ* reporter transgenes.**

Integrated strain	% transmission ( <i>rol-6(su1006)</i> )	Brood size	Adult assayed (n)
[P <sub>1.5kb lat-1::Exon1(lat-1)::LacZ-gfp;rol-6</sub> ][pAA411;pRF4]			
DA311	100%	285±7	10
DA312	100%	272±10	10
[P <sub>3.0kb lat-1::Exon1(lat-1)::LacZ-gfp;rol-6</sub> ][pAA412;pRF4]			
DA411	100%	281±5	10
DA412	100%	291±13	10
[ <i>LacZ-gfp;rol-6</i> ][pPD96.04;pRF4]			
DA511	100%	276±9	10

Strains are the integrated lines created from transgenic animals for micro-injection of individual reporter constructs; ~1.5kb *lat-1* construct, ~3kb *lat-1* construct, *LacZ-gfp*. The percentage of transmission for the integrated strains was measured for the adult transgenic offspring that transmit the roller phenotype. Brood size is the total number of offspring that exhibits roller phenotype per individual transgenic adult animal (Mean±Standard deviation); an adult hermaphrodite was singly plated and transferred every day, and offspring with roller phenotypes were counted. n is the number of adult transgenic animal assayed for the study

ated from integrated lines were bred against wild-type five times to remove any unwanted mu-

tation from background.

**Table 3.6 Integration of GFP reporter transgenes.**

Integrated strain	% transmission ( mCherry)	Brood size	Adult assayed (n)
[P <sub>1.5kb lat-1::Exon1(lat-1)::gfp;unc-54::mCherry</sub> ] [pAA410;pAA414]			
DA211	100%	297±4	10
DA212	100%	280±8	10
[ <i>gfp;unc-54::mCherry</i> ] [pEGFP;pAA414]			
DA920	100%	269±3	10

Strains are the integrated lines created from transgenic animals for micro- injection of individual reporter construct; ~1.5kb *gfp* construct or GFP plasmid. The percentage of transmission for the integrated strains was measured for the adult transgenic offspring that transmit selectable marker mCherry transgene. Brood size is the total number of offspring that transmits mCherry transgene per individual transgenic animal (Mean±Standard deviation); an adult hermaphrodite was singly plated and transferred everyday, and offspring with mCherry were counted. n is the number of adult transgenic animal assayed for the study

The *lat-1::lacZ* reporter gene constructs gave two integrated strains each and transmitted the integrated array at 100% with relative brood sizes as described in Table 3.5. The *lat-1::gfp* reporter gene construct also gave two integrated strains and transmits 100% integrated array with relative brood sizes as shown in Table 3.6. In the negative controls, each reporter gene (*lacZ* or *gfp*) has only one integrated strain and transmits the integrated array to 100% offspring. The results showed that the strains of *lacZ* reporter gene and *gfp* reporter gene obtained after irradiation transmit the array to all of the offspring and are, therefore, integrated arrays.

### Section 3.3.2.2 Characterisation of reporter gene expression

#### Section 3.3.2.2.1 Expression pattern of *lat-1::GFP* or *lat-1::LacZ* during embryonic development

To study the activation of the *lat-1* promoter during egg development, transgenic adult hermaphrodites were sliced open and eggs examined over time under the appropriate *gfp* filter as described in section 2.4.1. Egg development was followed from 40-cell stage; gastrulation period all through to 3-fold stage for the transgenic worm carrying ~1.5kb, 5' regulatory region



fused to *gfp* reporter gene, while different stages of the transgenic worms carrying either ~1.5kb or ~3kb, 5' regulatory region fused to *lacZ* reporter gene were stained for  $\beta$ -galactosidase expression, as it was not possible to follow egg development for histochemical staining (section 2.7.5). In the negative control, transgenic worms either carrying *gfp* or *lacZ* without insert were treated as described above.

Expression of the ~1.5kb and ~3kb, 5' regulatory regions fused to *lacZ* reporter gene respectively, was examined for any difference in the expression pattern. In 3-fold stage embryos,  $\beta$ -galactosidase expression detected corresponds to the positions of gut cell (Figure 3.7A). The expression pattern observed in ~1.5kb promoter of *lat-1* was similar to ~3kb promoter of *lat-1*, therefore both promoters drive reporter gene at the embryonic stage. Results from the negative control showed that  $\beta$ -galactosidase expression was not detected, showing that *rol-6* transgene did not cause spurious expression of the transgene by itself (data not shown).

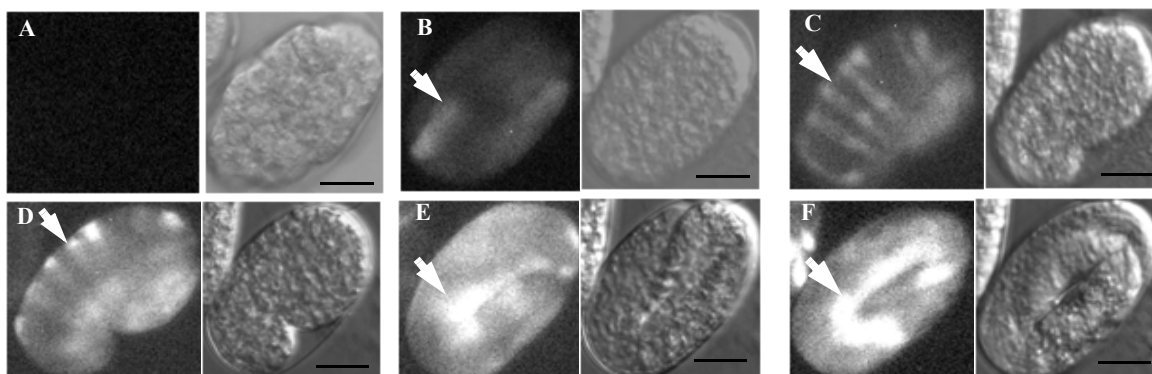

**Figure 3.6 Embryonic expression pattern of *lat-1::GFP*.** The diagram shows the photographs of different stages of embryo development of transgenic animal carrying ~1.5kb, 5' end of *lat-1* fused to *gfp* reporter gene. Embryos were dissected from integrated lines of transgenic animals. All images were taken under GFP filter and visible DIC using the same focal point (A) embryo at 40-cell stage before GFP detection (post-fertilization) (B) GFP fluorescence was first detected at the position of gut cells (white arrow), 60 mins post-fertilization (C) a dorsal sheet of gut cells (white arrow) intercalation (D) migration of dorsal gut cells (white arrow) (E) beginning of gut cells expression at 2-fold stage with twitching (white arrow) (F) gut cells expression at 3-fold stage (white arrow). Scale bar is 25 $\mu$ m, and all images were captured at 40x magnification.

The expression pattern of the 1.5kb, 5' regulatory region fused to the *gfp* reporter gene during

embryonic development was compared with either ~1.5kb or ~3kb, 5' regulatory region fused to *lacZ* reporter gene. During egg development, *gfp* fluorescence corresponding to gut cell was first detected 1hr post-fertilization (Figure 3.6B), before epidermal morphogenesis stage, then became higher in both intensity and number of fluorescent cells during later embryogenesis. Sixty minutes later, dorsal gut cells start intercalation during the early stage of epidermal enclosure (Figure 3.6C). Development of dorsal cell began toward the end of epidermal enclosure almost an hour later before the 2-fold stage (Figure 3.6D). At the 2-fold stage, the gut was apparent, and could be clearly seen at the 3-fold stage. However, twitching of the embryo during the 2 or 3-fold stage prevents extended exposures of gut cells.

When compared to expression pattern of either ~1.5kb or ~3kb, 5' regulatory region fused to *lacZ* reporter gene, staining of  $\beta$ -galactosidase corresponding to gut cell was consistently observed in 3-fold stage of embryo. From this experiment, the same expression pattern was noticed as observed in *gfp* embryonic expression. These data showed that the activity of the *lat-1* promoter was detected at different stages of embryonic development, particularly in gut cells. The study of embryo during development for the negative control (*gfp* without an insert) did not show any fluorescence, indicating there was no effect of mCherry transgene (data not shown).

#### **Section 3.3.2.2.2 Post embryonic expression of *lat-1* gene promoter**

The expression of the *lat-1* gene promoter was examined in transgenic animals using two different *lat-1* promoters, containing ~1.5kb and ~3kb of the 5' regulatory region fused to *lacZ* reporter gene respectively. The aim of this experiment was to find out any difference in the expression pattern between ~1.5kb and ~3kb promoter of *lat-1*. Integrated lines obtained from individual reporter constructs were analysed for the expression pattern of *lacZ*.

In the post-embryonic stages, a tail neuron cell and gut cell were observed in L1-L3 stages. A typical example of L1 stage is represented in Figure 3.7B-C. From L4 to adult stage,  $\beta$ -galac-

tosidase expression was strong in gut cells (Figure 3.7D-E). In the negative control, transgenic animals carrying *lacZ* and *rol-6* did not yield gut staining, indicating that *rol-6* transgene did not affect expression pattern (Figure 3.7F). The results show no difference in the expression pattern between ~1.5kb, 5'end of *lat-1* and ~3kb, 5'end of *lat-1*. These data showed that both ~1.5kb and ~3kb promoters of *lat-1* were individually capable of driving expression of reporter gene *lacZ* in the transgenic animals, therefore, they are both functional promoters.

The ~1.5kb promoter *lacZ* reporter construct was compared with ~1.5kb promoter fused to *gfp*. In ~1.5kb or ~3kb *lacZ* fusion, L1-L3 stage showed the same level of expression in gut and two tail neuron cells, but ~1.5kb *gfp* fusion showed strong gut cell expression in the body of L1-L3 stages. But, in the L4 to adult stage, the intensity of *gfp* fusion expression started diminishing restricting the expression to gut with two tail neurons identified to be PVQL and PVQR in the posterior region of the adult tail as shown in Figure 3.8D&F. Identification of the two tail neurons was based on the criteria set in the worm atlas for cell identification. A similar expression pattern of the *lacZ* fusion was seen in L4 to adult stage worms (Figure 3.7). The negative control experiment only showed mCherry fluorescent body-wall muscle expression of the animals that were transgenic for *gfp* vector and mCherry, indicating that no effect was caused by the mCherry transgene (Figure 3.8G). Therefore, the result shows a distinct expression pattern for gut cells of all stages with the *gfp* transcriptional fusion driven by ~1.5kb promoter of *lat-1* (Figure 3.8A-G).

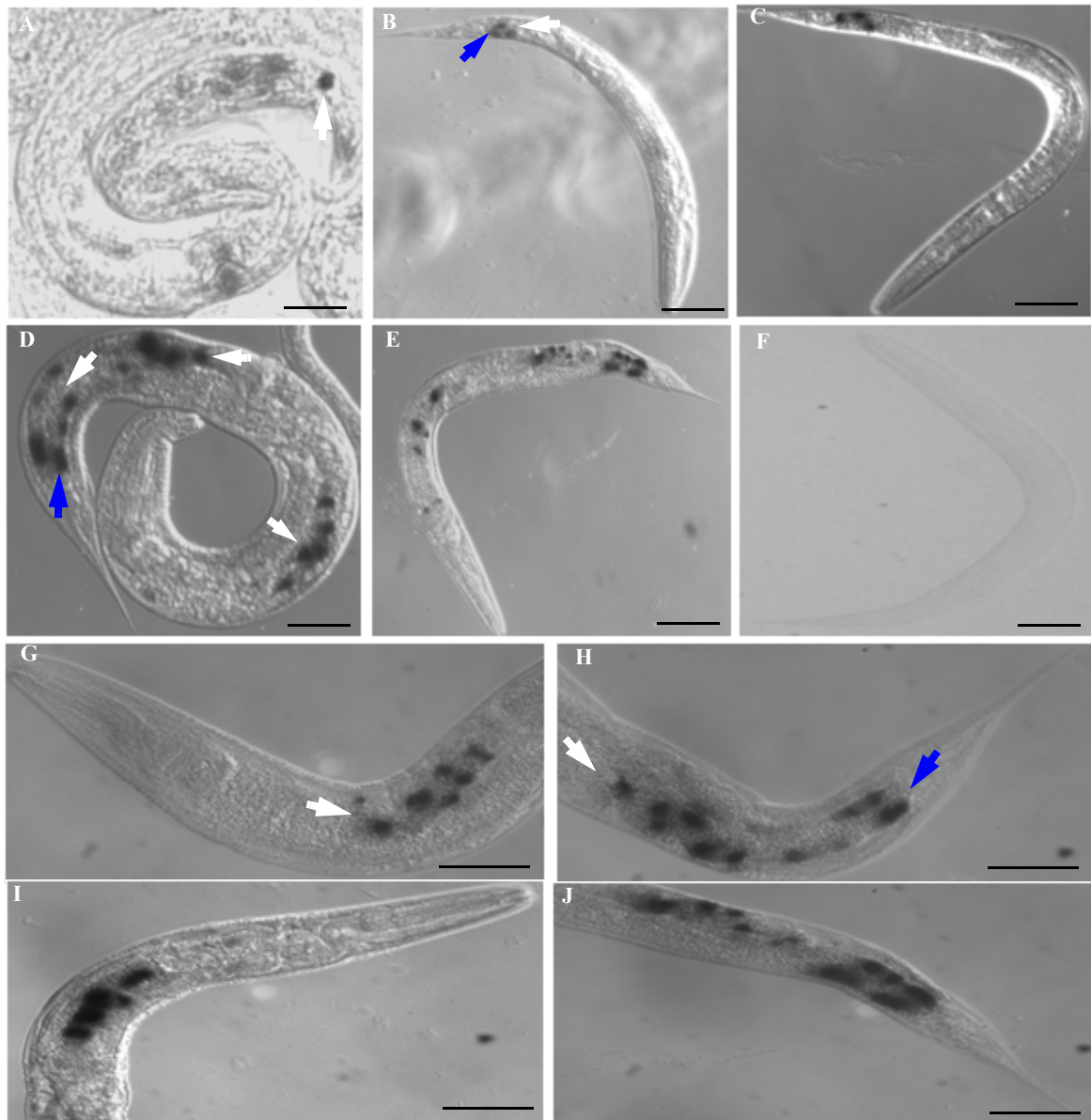

**Figure 3.7 Expression pattern of *lat-1::LacZ* in wild-type.** Integrated lines of transgenic animals carrying ~1.5kb, 5' end of *lat-1* reporter construct and ~3kb, 5' end of *lat-1* reporter construct were created respectively as described in Table 3.5. and stained for  $\beta$ -galactosidase (see section 2.4.7). (A) A typical example of ~1.5kb or ~3kb with  $\beta$ -galactosidase staining of gut cell (white arrow). (B) An example of L1 stage of ~1.5kb  $\beta$ -galactosidase expression showing tail neuron cell (blue arrow) and gut cell at the beginning of gut (white arrow). (C) An example of L1 stage ~3kb showing similar expression pattern. (D) L4 stage of ~1.5kb reporter expression of tail neuron cell (blue arrow), gut cell (white arrow), and the body twist of the animal is due to expression of selectable marker roller phenotype. (E) The L4 stage of ~3kb reporter construct shows similar expression pattern with L4 stage of ~1.5kb reporter construct. (F) The L4 stage of transgenic animal carrying *lacZ* and roller phenotype, but no expression of  $\beta$ -galactosidase. (G) The reporter expression of ~1.5kb construct at adult stage (anterior side) showing gut cell (white arrow). (H) The reporter expression of ~1.5kb construct at adult stage (posterior side) showing gut cell (white arrow), tail neuron cell (blue arrow), the twist in both pictures was due to roller phenotype. (I) The adult stage (anterior side) and (J) adult stage (posterior side) of ~3kb reporter construct similar to expression pattern of ~1.5kb reporter construct. Scale bar is 50  $\mu$ m. All images were captured at 100x magnification.

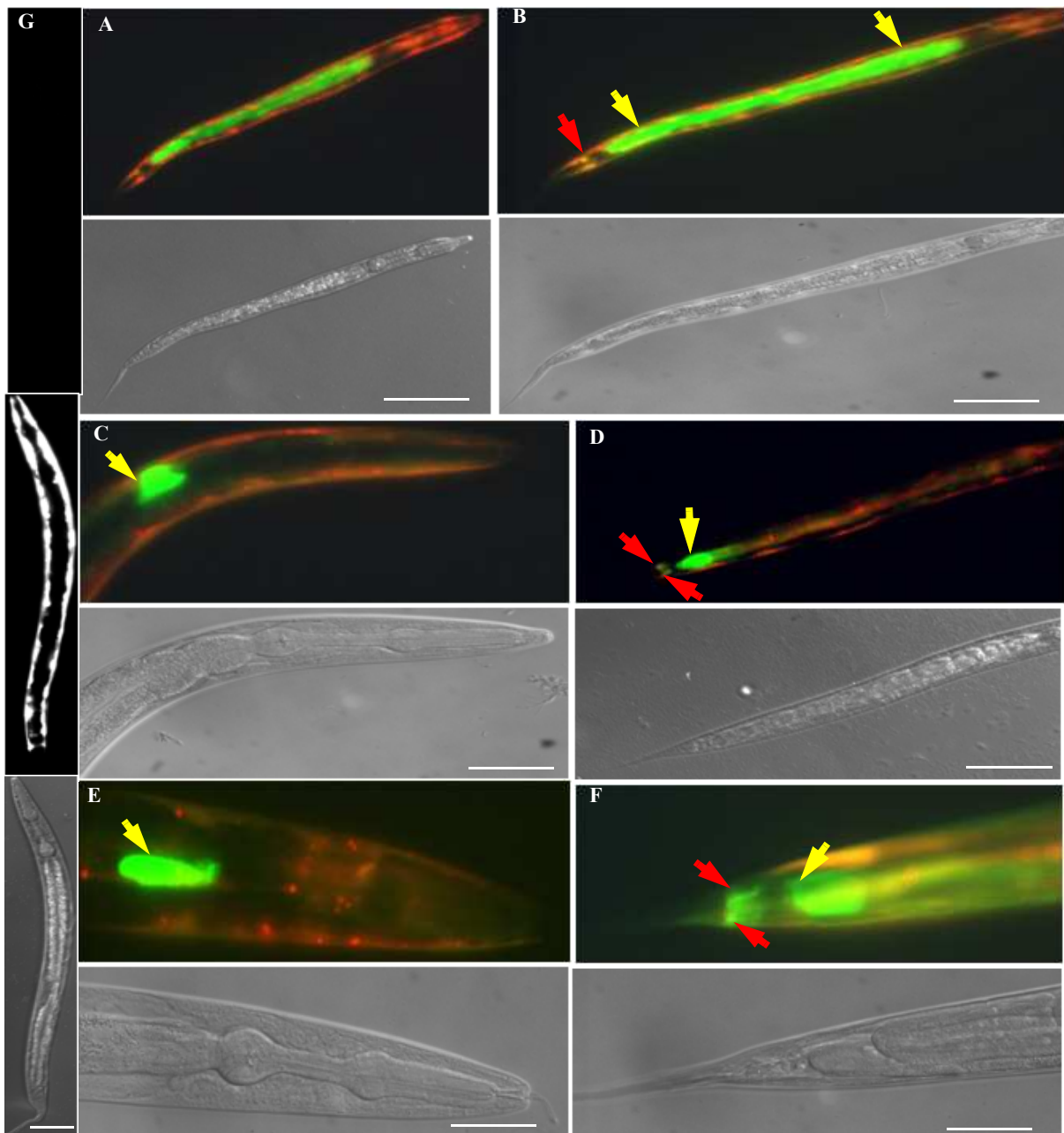

**Figure 3.8 Expression pattern of *lat-1::GFP* in wild-type.** Integrated lines of transgenic animals carrying ~1.5kb, 5'end of *lat-1* reporter construct was created as described in Table 3.6. All images were captured at 100x magnification for GFP expression under GFP filter, mCherry filter and visible DIC filter for pseudo-colour. (A & B) An example of L1 stage showing intensely fluorescent gut cells (yellow arrow) with developing tail neuron (red arrow), B image captured at higher magnification. (C) The L4 stage (anterior side) showing gut cell (yellow arrow). (D) The L4 stage (posterior side) showing gut cell (yellow arrow) and two tail neuron cells identified as PVQL and PVQR (two red arrows respectively). (E) The adult stage (anterior side) showing a gut cell (yellow arrow). (F) The adult stage (posterior side) showing two tail neurons (PVQL and PVQR) (two red arrows respectively) and gut cell (yellow arrow). (G) The L4 stage of transgenic animal carrying pEGFP and mCherry, image captured under GFP filter (black), image captured under mCherry filter showing body-wall muscle expression of mCherry and image captured under visible DIC showing autofluorescence. Scale bar is 50  $\mu\text{m}$ , all images captured at 100x, only A captured at 40x magnification

The result showed overlapping expression pattern between the *lacZ* and *gfp* fusion constructs. Expression pattern in the *lacZ* and *gfp* fusions with the *lat-1* promoter in L1-L3 stage worms showed tail neuron and gut cell from the beginning to the end of intestine (Figure 3.7 & Figure 3.8 A-B). The *lacZ* transcriptional fusion of ~1.5kb and ~3kb promoter of *lat-1* were detected in the same pattern at all developmental stages, from embryos all through to the adult stages. However,  $\beta$ -galactosidase and GFP are detected in intestinal cells of each developmental stage of all transgenic animals, and coupled with tail neuron cells detection which are obvious at the adult stage of transgenic animals. In summary, these results showed the same significant level of expression of ~1.5kb, ~3kb, 5' end of *lat-1 lacZ* fusion and ~1.5kb, 5' end of *lat-1 gfp* fusion. Hence, these data showed that all the *lat-1* promoter constructs tested are functional and confer a similar pattern of expression. Thus, the ~1.5kb *lat-1* promoter construct contains sufficient information to yield correct tissue-specific and developmental expression.

## **Section 3.4 Effect of B0457 cosmid**

### **Section 3.4.1 B0457 cosmid rescues the *lat-1* (ok1465) allele**

The *lat-1(ok1465)* allele has a deletion of the *lat-1* gene and ~95-98% of *lat-1(ok1465)* homozygous worms arrest or die before adulthood, with only ~2-5 adult offspring per animal (see section 3.3.1). However, it is unclear if this lethality is due to the deletion in the *lat-1* gene, or to adventitious mutations introduced during the process of mutagenesis to create this allele. Hence, it is necessary to complement the lethality of *lat-1(ok1465)* worms in order to prove that the *lat-1* gene is responsible for the phenotype. The B0457 cosmid contains the full-sequence of the *lat-1* gene, and was tested to see if it rescues embryonic lethality of *lat-1(ok1465)* worms before determining functional regions within the cosmid. Therefore, B0457 cosmid DNA and CFP were co-injected into *lat-1* worms, while CFP selectable marker only was injected into *lat-*

1 worms as a negative control.

**Table 3.7** Effect of B0457 Cosmid and *unc-54::cfp* DNA on *lat-1* (ok1465) worms.

DNA injected	Transgenic embryo (F <sub>1</sub> )	Transgenic adult (F <sub>1</sub> )	Stable transgenic line
<i>B0457;unc-54::cfp</i>	20	20	18*
	12	12	6
	26	26	15
	23	23	17
	27	27	20
	Total	108 <sup>a</sup>	108 <sup>a</sup>
<i>unc-54::cfp</i> (CFP)	8	0	0
	10	1	0
	6	0	0
	12	1	0
	18	2	0
	24	2	0
	9	0	0
Total	87 <sup>b</sup>	6 <sup>b</sup>	0

DNA was injected into the syncytial gonad of *lat-1* (ok1465) worms at a concentration of 50-100µg/ml, and transgenic offspring were determined by the presence of blue fluorescence in the body wall; uninjected animals yielded no offspring with blue fluorescence (data not shown). The number of transgenic embryos, transgenic adults and stable transgenic lines from each animal is shown. The statistical significance of the proportion of transgenic worms surviving to adulthood between *B0457;unc-54::cfp* and CFP was determined by a Chi squared test, and the difference between <sup>a</sup> and <sup>b</sup> was found to be highly significant ( $P < 0.05$ ). \* includes a stable line with 100% transmission of the array.

The idea of injecting CFP is to ensure that rescue of *lat-1* worms is not caused by the effect of CFP. Five different injected F<sub>0</sub> worms gave rise to independent stable lines from injection of B0457 and CFP, as indicated by blue fluorescent body-wall muscle expression from early embryogenesis to adulthood. In the negative control, seven different injected F<sub>0</sub> worms with CFP produced blue fluorescent embryos, with six transgenic F<sub>1</sub> reaching adulthood without producing any stable lines (Table 3.7). After injection with the plasmid CFP, there were six surviving adults from >80 transgenic embryos. The statistical significance of the difference in proportion of embryos that reached adulthood after injection of *B0457;unc-54::cfp* or CFP, was deter-

mined by  $\chi^2$  analysis, and found to be statistically significant ( $P < 0.0001$ ). Therefore, the B0457 cosmid rescued the lethality of *lat-1(ok1465)* worms.

### Section 3.4.1.1 Stability of *unc-54::cfp* transgene on *lat-1(ok1465)* worms

The stability of the CFP transgene was investigated for five independent stable lines obtained in Table 3.7. Each stable line yielded one strain (DA601-605), as named in Table 3.8, and the strains transmit the CFP to progeny at between 95%-100%. All the strains were examined for brood size and the percentage of transmission of the extrachromosomal array was assayed by measurement of the blue fluorescence from CFP.

**Table 3.8** The *unc-54::cfp* transgene stability .

Stable transgenic strain	% transmission ( CFP)	Brood Size	Adult assayed
DA601	100%	282±6	20
DA602	97%	272±4	10
DA603	95%	257±12	10
DA604	95%	276±7	15
DA605	98%	284±10	15

Strain DA601-DA605 are the transgenic stable lines obtained from injection of *unc-54::cfp* transgene. The percentage of transmission was measured for the adult transgenic offspring that transmit CFP (blue fluorescence); the number of transgenic adult was divided over the total number of offspring including offspring without *cfp* (blue fluorescence). Brood size is the total number of offspring per individual animal (Mean ± Standard ); an adult hermaphrodite was singly plated and transferred everyday, offsprings with CFP (blue fluorescence) were counted. n is the number of adult transgenic animal assayed for the study.

Strain DA601 is the only tested stable line that transmits 100% CFP transgene with brood size of 282±6 from all 18 lines obtained, other tested stable lines transmit below 100% (Table 3.8). The result shows that the level of stability from five independent stable lines differ from one another as reflected in the percentage of transmission of CFP transgene and brood sizes. One line was examined to ascertain if the extrachromosomal array introduced via microinjection is integrated into a chromosomal site in the transgenic worms. The transgenic stable strain that



shows 100% transmission of the array was chosen for the outcross analysis. Wild-type males

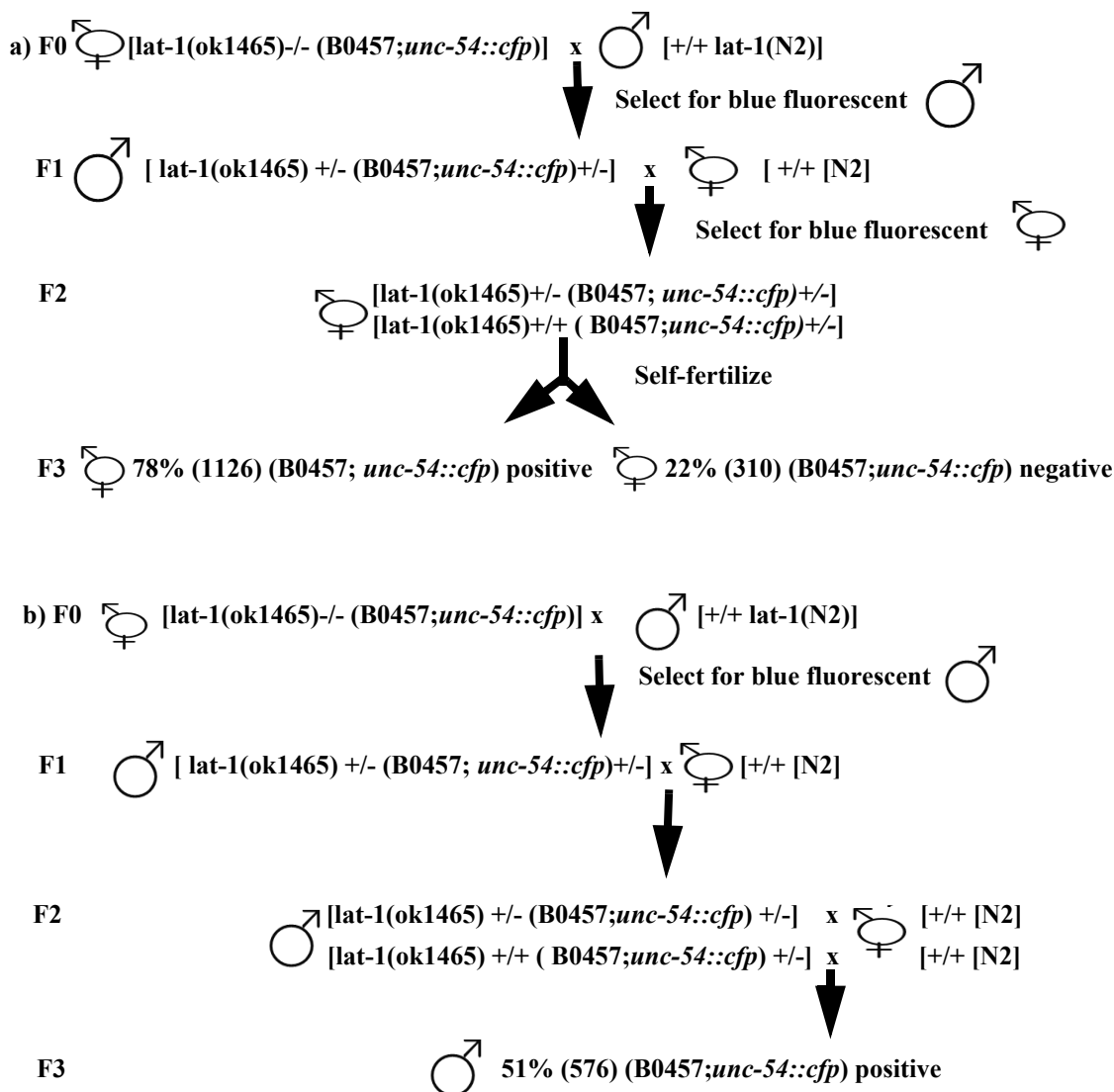

**Figure 3.9 Segregation of (B0457;unc-54::cfp) transgene.** The figure shows annotated diagram of outcross analysis between B0457, *unc-54::cfp* on *lat-1* (ok1465) worms and N2-wildtype. **a)** F<sub>0</sub> represents the start of the cross for L4 transgenic hermaphrodites (-/-) against young N2 wild-type (+/+). Blue fluorescent transgenic male progeny F<sub>1</sub> (+/-) was selected and was crossed to L4 hermaphrodite N2 wild-type (+/+). F<sub>2</sub> blue transgenic hermaphrodite progeny (+/-,+/+) was selected but on two different chromosomes and self-fertilize, leading to a total number of 1126 progeny blue fluorescent (78%) and a total number of 310 progeny non-blue fluorescent (22%). **b)** F<sub>0</sub> represents the start of the cross for L4 transgenic hermaphrodites (-/-) against young N2 wild-type (+/+). Blue fluorescent transgenic male progeny F<sub>1</sub> (+/-) was selected and was crossed to L4 hermaphrodite N2 wild-type (+/+). F<sub>2</sub> blue fluorescent transgenic male progeny (+/-,+/+) was selected but on two different chromosomes and was crossed to L4 hermaphrodite N2 wild-type (+/+) producing total number of 576 male progeny 51% (+/-). Five individual sets of experiment were set up for all the crosses and this was repeated two times.

Hermaphrodite



male



(N2 Bristol) were crossed against transgenic hermaphrodites with B0457;*unc-54::cfp*, producing a total number of 568 males and 556 hermaphrodites.

Resulting males showing body wall fluorescence (i.e. *unc-54::cfp*) were crossed to wild-type hermaphrodite (N2 Bristol). From the progeny of this cross, L4 transgenic hermaphrodites showing body wall fluorescence were placed individually on plates and allowed to self-fertilize. The progeny were screened for the presence and absence of the blue fluorescence, and the outcome of cross analysis for the ratio was calculated by  $\chi^2$ -test to determine whether the results fit or deviate from Mendelian genetics. There were 1126 blue fluorescent transgenic hermaphrodites (78%) and 310 non-fluorescent wild type hermaphrodites (22%), which is not significantly different from the expected Mendelian ratio of blue fluorescent (75%) and non-fluorescent (25%) ( $\chi^2$ -test,  $P > 0.05$ ). Another cross was done in parallel by taking heterozygous F<sub>2</sub> males with B0457;*unc-54::cfp* and crossed to wild-type hermaphrodites. The offspring (1130) had 576 male offspring that were blue-fluorescent (51%), which is not significantly different compared to an expected result of 50% ( $\chi^2$ -test,  $P > 0.05$ ). Five individual sets of experiment were set up for all the crosses and repeated two times to confirm the same result. The results show that this particular stable line exhibits Mendelian segregation of array and, therefore, is integrated.

### **Section 3.4.2 Phenotypic effect of B0457 cosmid and CFP on lat-1 (ok1465) worms**

The phenotypic effect of the B0457 cosmid and CFP on lat-1 (ok1465) was studied to find out if the micro-injection of the transgene rescued lat-1(ok1465) brood size and defecation cycle defects. This analysis of transgene should define the role of the B0457 cosmid (containing the full sequence of lat-1 gene) in rescuing of lat-1(ok1465) phenotypes. Therefore, it is important to

characterise the rescued lat-1 animals and compare with wild-type. DA601, an integrated line (Table 3.8) containing B0457 and CFP on the lat-1(ok1465) background, was examined for developmental lethality, brood size and defecation cycle.

#### **Section 3.4.2.1 Effect of B0457 on developmental lethality in lat-1(ok1465)**

Developmental lethality was determined by counting the number of embryos per animal for a period of seven days until they stopped laying eggs, and comparing this to the number of adults produced from these embryos. The number of embryos and adults counted from B0457;*unc-54::cfp* on lat-1(ok1465) worms and wild-type worms were not significantly different ( $286\pm 6$  and  $304\pm 14$ ), whereas in the lat-1 (ok1465), only 3 offspring per animal reached adulthood (Table 3.9). P values were calculated relative to wild-type by t-test analysis to determine level of significance. N2 worms gave rise to  $304\pm 14$  offspring per adult, while the lat-1 worms showed a slightly reduced number of embryos laid ( $220\pm 13$ ;  $P<0.05$ ), and the number of surviving adults was greatly reduced, at  $3\pm 8$  offspring per adult: this was significantly different from N2 worms ( $P<0.0001$ ). However, lat-1 animals carrying the B0457 cosmid laid  $286\pm 6$  embryos per animal ( $P<0.05$ , compared to lat-1), and the number of surviving adult offspring per animal was  $286\pm 6$  ( $P<0.0001$ , compared to lat-1). Thus, lat-1 animals show small numbers of surviving adult offspring due to lethality during embryogenesis and larval stages (Section 3.2.2). Lat-1 homozygotes carrying the B0457 cosmid show rescue of this phenotype close to the levels seen in N2 worms. Since it has been shown that the effect on survival is due to the B0457 cosmid, and not to the CFP marker gene (Section 3.4.1), this shows that the B0457 cosmid rescues the effects of the lat-1(ok1465) allele on embryonic and larval lethality.

#### **Section 3.4.2.2 Effect of B0457 on defecation cycle in lat-1(ok1465) worms**

Lat-1(ok1465) worms have a lengthened defecation cycle, with a pBOC-pBOC interval of 80

seconds (DRB, unpublished data). This defecation cycle is abnormal when compared to wild-type, which defecate every 45 seconds [64]. The effect of B0457 cosmid on *lat-1* (*ok1465*) worms was investigated to find out if it rescued the defecation cycle defect. Defecation cycle analysis (pBoc to pBoc (posterior body muscle contraction)) was carried out as described [63], [98]. Single L4 hermaphrodites were incubated over-night at 20°C on bacteria seeded plate and studied for defecation using Etho [98] software at 20°C room. The *lat-1* animals showed a significantly prolonged defecation cycle ( $80 \pm 10$  seconds), compared to wild-type worms ( $45 \pm 3$  seconds,  $P < 0.0001$ ). *lat-1(ok1465)* animals that were transgenic for B0457 had a reduced defecation cycle compared to the *lat-1(ok1465)* parental stock ( $50 \pm 7$ ,  $P < 0.0001$ ). The N2 worms and B0457 on *lat-1* animal has a defecation cycle close to the level of wild-type as described in other literature [64], [99] (Table 3.9).

**Table 3.9 The B0457 cosmid rescues *lat-1(ok1465)* phenotypes.**

Genotype	No of embryo	Brood size	Defecation cycle (s)	Adults assayed (n)
N2	304±14	304±14	45±3	10
<i>lat-1(ok1465)</i>	220±13	3±8 <sup>b</sup>	80±10 <sup>b</sup>	10
Strain DA 601	286±6	286±6 <sup>b</sup>	50±7 <sup>b</sup>	15

All the genotypes are described above. Table depicts the Mean ± Standard deviation of brood sizes (defined as surviving adult progeny) and defecation cycle of all the genotypes; N2 wild-type, *lat-1(ok1465)*, Strain DA 601 at 20°C. Brood size is defined as total number of progeny that reached adulthood over the life time of a single hermaphrodite. P values were calculated between *lat-1* and N2, and Strain DA 601 and *lat-1*, and  $P < 0.05$  is indicated (<sup>b</sup>). (n) is the number of adult assayed.

These data show that *lat-1(ok1465)* worms transgenic for both cosmid B0457 and *unc-54::cfp* show rescue of the defecation cycle defect in *lat-1(ok1465)* worms. It was not possible to obtain *lat-1(ok1465)* worms with CFP, as a result of the low survival of these worms (Section 3.4.1), and so it is not possible to prove that the rescue of the defecation cycle defect is due to the B0457 cosmid and not the CFP construct. However, in view of the fact that it is the B0457 cosmid, and not the CFP construct, that rescues the lethality in the *lat-1(ok1465)* worms, it is likely that the

defect in defecation cycle is rescued by the B0457 cosmid also.

In summary, these results show significant difference in terms of increase in brood size and length of defecation cycle in *lat-1(ok1465)* worms that had been injected with the B0457 cosmid. Presence of *lat-1* gene on B0457 cosmid is likely to be responsible for the rescue of *lat-1(ok1465)* worms phenotype, even though some other genes are present on B0457 cosmid. Hence, these data suggest that it is the *lat-1* gene deletion that is important in altering embryonic developmental processes and defecation cycle control in the *lat-1(ok1465)* worm.

## Section 3.5 Analysis of *lat-1* gene

### Section 3.5.1 Full-length *lat-1a* cDNA rescued the *lat-1(ok1465)* worms

The B0457 cosmid, containing the full sequence of the *lat-1* gene, rescued the lethality of *lat-1(ok1465)* worms (Figure 3.3A-B), but this experiment did not prove whether it was the presence of the *lat-1* gene, or another gene on the B0457 cosmid, that was responsible for the rescue of lethality in *lat-1(ok1465)* worms. Therefore, the hypothesis that the *lat-1* gene was responsible for rescue of the *lat-1(ok1465)* phenotype was investigated by introducing a *lat-1* cDNA into these worms. There are three *lat-1* transcripts arising from differential exon splicing, designated *lat-1 a-c*; the “c” transcript is likely to be non-functional, and *lat-1a* was arbitrarily selected for

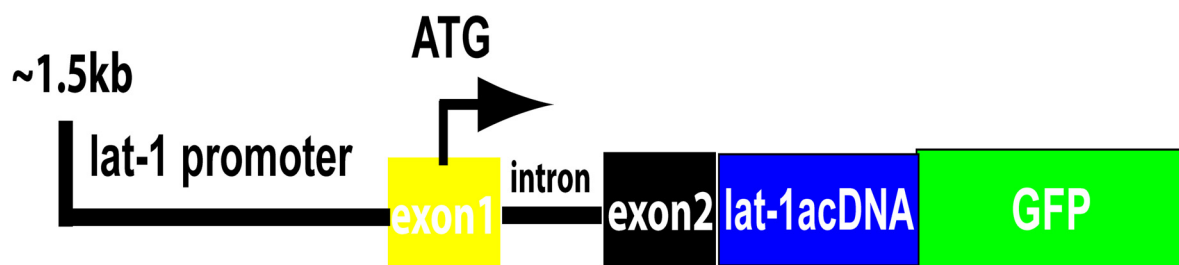

**Figure 3.10** Expression construct for full-length *lat-1a* cDNA. The cartoon shows in-frame translational fusion of *lat-1a* cDNA to the reporter gene, GFP. ~1.5kb of the 5' end of *lat-1* promoter contains the endogenous start codon ATG (black arrow) in the middle of exon 1 (yellow) with an intron (black line) and exon 2 (black box) with *lat-1a* cDNA (blue box) fused to green fluorescent protein GFP (green box), resulting construct is designated as pAA401. ( see section 2.10.2)

testing. A cartoon of the *lat-1a* construct for transgenesis is shown in Figure 3.10; the construct is driven by ~1.5kb of the 5' end of endogenous *lat-1* promoter, with *lat-1a* exons 1 and exon 2 fused to the remainder of the *lat-1a* cDNA, and fused in-frame at the C-terminus with GFP. This plasmid is full-length *lat-1a* cDNA [ $P_{1.5\text{kb} \text{ lat-1}}::\text{FL}(\text{lat-1a cDNA})::\text{gfp}$ ], designated as [pAA401] (Figure 3.10).

The full-length *lat-1a* cDNA was co-injected with mCherry (*unc-54::mCherry*, pAA414) as a selectable marker into *lat-1* (ok1465) worms. The mCherry was injected into *lat-1* (ok1465) worms as a negative control to ensure that any rescue effect is not caused by the marker.

**Table 3.10** Effect of full-length *lat-1a* cDNA and mCherry DNA on *lat-1*(ok1465) worms.

DNA injected	Transgenic embryo (F <sub>1</sub> )	Transgenic adult (F <sub>1</sub> )	Stable transgenic line
[ $P_{1.5\text{kb} \text{ lat-1}}::\text{FL}(\text{lat-1a cDNA})::\text{gfp};\text{unc-54}::\text{mCherry}$ ][pAA401;pAA414]	27	27	13*
	25	25	14
	17	17	9
	21	21	12
Total	90 <sup>a</sup>	90 <sup>a</sup>	48
[ <i>unc-54::mCherry</i> ][pAA414]	16	1	0
	13	0	0
	22	2	0
Total	51 <sup>b</sup>	3 <sup>b</sup>	0

The plasmid DNA from full-length *lat-1a* cDNA or mCherry construct was injected into the syncytial gonad of *lat-1*(ok1465) worms at a concentration of 50-100µg/ml. Transgenic offspring obtained were characterised by the presence of red fluorescence in the body wall, while uninjected animals yielded no offspring with red fluorescence (data not shown). The number of transgenic embryos, transgenic adults and stable transgenic lines from each animal is shown. The statistical significance of the proportion of transgenic worms surviving to adulthood between full-length plasmid and mCherry plasmid was determined by a Chi squared test ( $\chi^2$  analysis) and difference between <sup>a</sup>&<sup>b</sup> was found to be significant ( $P<0.05$ ). \* includes a stable line with 100% transmission of array.

Transgenic worms were readily identifiable by red fluorescent body-wall muscle expression using the mCherry red filter. Four different injected F<sub>0</sub> worms gave rise to independent stable lines from co-injection of full-length *lat-1a* cDNA and mCherry. In the negative control, three differ-

ent F<sub>0</sub> worms injected with mCherry produced 51 red fluorescent embryos, with only 3 transgenic F<sub>1</sub> reaching adulthood, with none producing transgenic offspring (Table 3.10). The statistical significance of the difference in proportion of transgenic embryo that reached adulthood after injection of full-length plasmid or mCherry plasmid was determined by  $\chi^2$  analysis, and found to be statistically significant (P<0.0001). This result shows that when the lat-1a fusion protein was driven by the endogenous lat-1 promoter, it rescued the lethality of lat-1(ok1465) worms. This result shows that the lat-1a protein is capable of rescuing the lethality of lat-1(ok1465) worms, and therefore that the lat-1a protein is functional, and is not adversely affected by the C-terminal fusion of a GFP sequence. Although this construct was capable of complementing the lethality in the lat-1(ok1465) strain, there was a failure to detect GFP in the adult transgenic animals. It can be concluded that the lat-1a-GFP fusion is expressed, but that the failure to detect GFP fluorescence might be due to low levels of expression of the lat-1a-GFP fusion protein, or to restricted developmental expression.

### Section 3.5.1.1 Stability of mCherry transgene of lat-1a cDNA on lat-1(ok1465) worms

Four independent stable lines obtained from micro-injection of full-length lat-1a cDNA were

**Table 3.11 The mCherry transgene stability of lat-1a cDNA .**

Stable transgenic strain	% transmission (mCherry)	Brood size	Adults assayed (n)
[P <sub>1.5kblat-1</sub> ::FL(lat-1a cDNA):: <i>gfp</i> ; <i>unc-54</i> :: <i>m-cherry</i> ][pAA401;pAA414]			
DA 101	100%	339±7	20
DA 102	98%	284±6	15
DA 103	99%	282±10	15
DA 104	99%	276±5	15

Each transgenic strain was examined for percentage transmission of the mCherry gene, and brood size as described in the Table 3.11. The percentage of transmission with mCherry plasmid is the percentage of transgenic adult with red fluorescence. Brood size is the total number of transgenic adult offspring per individual animal (Mean ± Standard Deviation). n is the number of adult transgenic animal assayed for the study.

assayed for stability by measuring red fluorescence from mCherry. Each stable line tested

(DA101-104) is named in Table 3.11, and the strain transmits mCherry to progeny at between 98%-100%.

The result shows that the transgene stability varies between strains as demonstrated in the percentage of mCherry positive offspring and brood sizes. Strain DA 101 showed 100% transmission, and was examined to find out if the extrachromosomal array was fully integrated into chromosomal site of transgenic animal as described in section 3.4.1. The results showed that strain DA 101 exhibits mendelian inheritance (data not shown); therefore, it is an integrated line.

### Section 3.5.1.2 Phenotypic effect of lat-1a cDNA and mCherry on lat-1 (ok1465) worms

#### Section 3.5.1.2.1 Effect of lat-1a cDNA on developmental lethality

The effect of full-length lat-1a cDNA plasmid on lethality in lat-1(ok1465) worms was examined in strain DA 101 by counting the number of embryos and surviving offspring. Wild-type worms produced  $315 \pm 14$  adult offspring per animal, while the lat-1(ok1465) produced significantly less adult offspring,  $3 \pm 2$ . Introducing the lat-1a cDNA increased the number of surviving adults in lat-1(ok1465) worms to  $339 \pm 7$ , significantly increased compared to the lat-1(ok1465) animals. The number of embryos laid by lat-1 worms was reduced by ~30% compared to N2 worms ( $222 \pm 7$ ;  $P < 0.0001$ ), but was significantly increased by the introduction of the lat-1 transgene (Table 3.12).

**Table 3.12** Effect of lat-1a cDNA on lat-1 (ok1465) lethality.

Genotype	No of embryos	Brood size	Defecation cycle (s)	Adults assayed (n)
Wild-type	$315 \pm 14$	$315 \pm 14$	$45 \pm 7$	10
lat-1(ok1465) worm	$222 \pm 7$	$3 \pm 2^b$	$80 \pm 11^b$	10
Strain DA 101 (Full-length )	$339 \pm 7$	$339 \pm 7^b$	$49 \pm 4^b$	20

Wild-type, lat-1(ok1465) worm and Strain DA101 (full-length lat-1a cDNA) were assayed at 20°C. The table depicts the Mean±Standard deviation for number of embryos, brood size (defined as surviving transgenic adult progeny) and defecation cycle for each genotypes. P values were calculated between lat-1 (ok1465) worm and wild-type, and between Strain DA 101 and lat-1(ok1465) worm, and  $P < 0.05$  is indicated (<sup>b</sup>). n is the number of adults assayed.



Table 3.10 shows that the introduction of the lat-1 and mCherry cDNAs rescued defects in embryo number and developmental lethality in the lat-1(ok1465) line; given that Table 3.10 shows that the lat-1 plasmid is required to obtain viable offspring, it can be concluded that the mCherry cDNA is not required for rescue of developmental lethality in this strain, and that the lat-1a cDNA fusion is sufficient to rescue the developmental lethality of the lat-1(ok1465) line.

#### **Section 3.5.1.2.2 Effect of full-length lat-1a cDNA on defecation cycle**

Defecation cycle lengths were measured for wild-type and lat-1(ok1465) worms, and strain DA101. The lat-1(ok1465) worms shows significantly prolonged defecation cycles ( $80 \pm 11$  seconds) compared to N2 wild-type ( $45 \pm 7$  seconds,  $P < 0.0001$ ). Transgenic lat-1(ok1465) animals with the full-length lat-1a cDNA had a significant reduction in defecation cycle length compared to lat-1(ok1465) worms ( $49 \pm 4$ ,  $P < 0.0001$ ), and the length of defecation cycle is close to wild-type. This result shows that the lat-1a cDNA construct rescued the defecation cycle defect in lat-1(ok1465) worms. The mCherry plasmid failed to produce transgenic animals as a result of embryo lethality (Table 3.10), and that suggests that the rescue of defecation cycle was due to full-length lat-1a cDNA, not the mCherry construct.

In summary, these results show that the absence of the lat-1 gene affects embryonic and larval developmental processes, and defecation cycle control in the lat-1 (ok1465) worms. Moreover, these data demonstrate that full-length lat-1a cDNA was capable of rescuing lat-1(ok1465) offspring lethality and defecation cycle. Therefore, the lat-1a cDNA encodes a functional lat-1a protein.

#### **Section 3.5.2 Identification of functional domains of lat-1a**

The ability of the lat-1a cDNA to rescue the lethality defect in the lat-1(ok1465) worms provides a simple assay for the endogenous function of the gene. It is possible to identify the functional regions within lat-1a cDNA since it is not clear what roles each region plays in the rescue of lat-

1(ok1465) worms. Therefore, identification of regions required for rescue of lat-1(ok1465) worms should define functional domains within lat-1a protein, and provide information about the role of these domains; the investigation has been split up into investigating C-terminal or N-terminal deletion series of the lat-1a cDNA.

### Section 3.5.2.1 Role of the lat-1a C-terminus

The lat-1a protein has a relatively large C-terminus for a member of the GPCR family, and in-

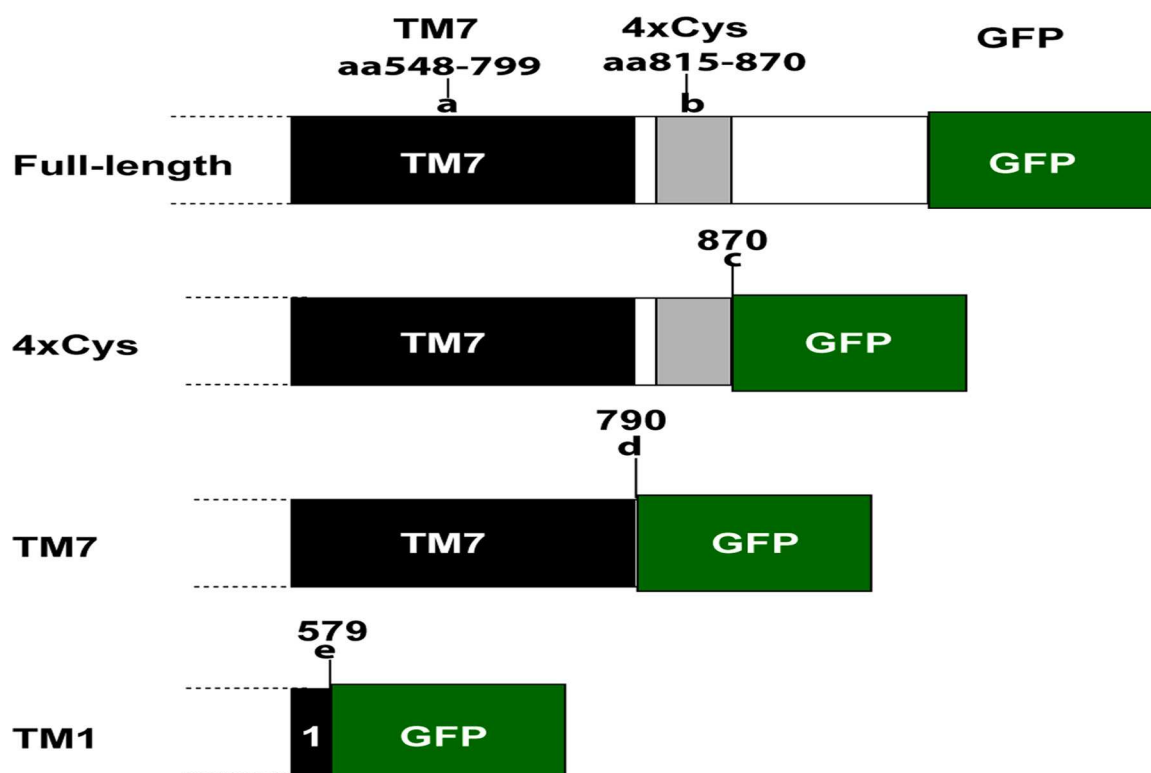

**Figure 3.11** Cartoon depicting C-terminal deletions of lat-1a. The first structure shows the full-length lat-1a cDNA fused to green fluorescent protein (GFP) which has two functional domains with their relative positions (a) seven transmembrane domain (TM7) in black colour at amino acid positions between 548-799 and (b) four cysteine domain (4xCys) in gray colour at amino acid positions between 815-870. (c) four cysteine domain (4xCys) truncated at amino acid 870. (d) seven transmembrane domain (TM7) truncated at amino acid 799. (e) transmembrane domain one (TM1) truncated at amino acid 579. The dotted lines represent the continuation of full-length lat-1a cDNA towards the native N-terminus in each construct described above.

cludes identifiable domains such as the four cysteine domain and the canonical GPCR seven transmembrane domain. To determine the functional roles of C-terminal domains, a series of C-terminal truncations were created, terminating at the four cysteine domain (amino acid 870, “4xCys”), the seven transmembrane domain (amino acid 790 “TM7”) and at the end of the first

transmembrane domain (amino acid 579 “TM1”) (Figure 3.11).

Each truncated C-terminal clone was translationally fused in-frame at the C-terminus with GFP and placed under the control of the ~1.5kb *lat-1* promoter used in the previous section (Figure 3.10). The plasmids are designated as 4xCys [*P*<sub>1.5kb *lat-1*</sub>::4xCys(*lat-1a* cDNA)::*gfp*] or [pAA402]; TM7 [*P*<sub>1.5kb *lat-1*</sub>::TM7(*lat-1a* cDNA)::*gfp*] or [pAA403]; and TM1 [*P*<sub>1.5kblat-1</sub>::TM1(*lat-1a* cDNA)::*gfp*] or [pAA407]. The effect of C-terminal truncations was tested on the ability to rescue *lat-1(ok1465)* worms. Individual C-terminus constructs were co-injected with

**Table 3.13** Effect of C-terminal *lat-1a* cDNA and m-Cherry DNA on *lat-1(ok1465)* worms.

DNA injected	Transgenic embryo (F <sub>1</sub> )	Transgenic adult (F <sub>1</sub> )	Stable transgenic line
[ <i>P</i> <sub>1.5kblat-1</sub> ::4xCys( <i>lat-1a</i> cDNA):: <i>gfp</i> ;unc-54::mCherry][pAA402;pAA414]	19	19	10*
	26	26	13
	18	18	10
Total	63 <sup>a</sup>	63 <sup>a</sup>	
[ <i>P</i> <sub>1.5kblat-1</sub> ::TM7( <i>lat-1a</i> cDNA):: <i>gfp</i> ;unc-54::mCherry] [pAA403;pAA414]	24	9	2
	17	4	1
	13	3	0
Total	54 <sup>b</sup>	16 <sup>b</sup>	3
[ <i>P</i> <sub>1.5kblat-1</sub> ::TM1( <i>lat-1a</i> cDNA):: <i>gfp</i> ;unc-54::mCherry] [pAA407;pAA414]	18	0	0
	15	0	0
	25	0	0
Total	58 <sup>c</sup>	0 <sup>c</sup>	0
[unc-54::mCherry] [pAA414]	18	2	0
	14	1	0
	8	0	0
	10	0	0
Total	50 <sup>d</sup>	3 <sup>d</sup>	0

The syncytial gonad of *lat-1(ok1465)* worms were injected at the concentration of 50-100µg/ml with plasmid DNA from each construct as shown in the Table 3.13. Transgenic offspring obtained were examined for the presence of red fluorescence in the body-wall muscle. The number of transgenic embryos, transgenic adults and stable transgenic lines from each animal is shown. The statistical significance of the proportion of transgenic worms surviving to adulthood between 4xCys plasmid, TM7 plasmid or TM1 plasmid and mCherry plasmid was determined by a Chi squared test, and the difference between <sup>a</sup> & <sup>d</sup>, <sup>b</sup>&<sup>d</sup>, was found to be highly significant (P<0.05), whereas there was no significant difference between <sup>c</sup>&<sup>d</sup> (P=0.1613). \* includes a stable line with 100% transmission of the array

the selectable marker, mCherry, into lat-1(ok1465) worms, while the selectable marker was injected into lat-1(ok1465) worms as a negative control. The 4xCys construct produced independent stable lines from three different injected F<sub>0</sub> worms, the TM7 construct produced independent stable lines from three different injected F<sub>0</sub> worms, but the TM1 construct did not produce any transgenic adults or stable lines from four different injected F<sub>0</sub> worms.

In the negative control, four different injected F<sub>0</sub> worms with mCherry produced red fluorescent embryos, with only 2 transgenic F<sub>1</sub> reaching adulthood and no stable lines (Table 3.13). The difference in proportion of embryos that reached adulthood after injection of individual construct or selectable marker was examined by  $\chi^2$  test analysis. The results were found to be significantly different from the mCherry control for the 4xCys and TM7 plasmids, but not for the TM1 plasmid. This result provides preliminary evidence that sequences C-terminal to the 4xCys domain are not required to rescue the lethality of lat-1 (ok1465) worms, and that the 4xCys domain has an important role, since truncation back to the seven transmembrane domain resulted in only partial rescue of the lethality of lat-1 (ok1465) worms, while one transmembrane domain failed

**Table 3.14 The mCherry transgene of C-terminal lat-1a cDNA stability.**

Stable transgenic strain	% transmission (mCherry)	Brood size	Adults assayed (n)
[P <sub>1.5kblat-1</sub> ::4xCys(lat-1a cDNA):: <i>gfp;unc-54::mCherry</i> ][pAA402;pAA414]			
DA 201	100%	223±15	15
DA 202	98%	198±9	15
DA 203	99%	213±11	15
[P <sub>1.5kblat-1</sub> ::TM7(lat-1a cDNA):: <i>gfp;unc-54::mCherry</i> ] [pAA403;pAA414]			
DA 301	99%	18±16	10
DA 302	99%	20±10	10

Transgenic strain from each tested stable line was examined for percentage of transmission and brood size as described above in the Table 3.14. The percentage of transmission with mCherry plasmid is the proportion of offspring that reached adulthood with red fluorescence. Brood size is the total number of transgenic adult per individual animal (Mean ± Standard ). n is the number of adult transgenic animal assayed for the study.

to rescue the lethality of *lat-1* (ok1465) worms. The TM7 domain is absolutely required, since deletion of this region yields no rescue of the lethality defect of the *lat-1*(ok1465) worms.

### Section 3.5.2.1.1 Stability of mCherry transgene in transgenic *lat-1* (ok1465) worms

The stability of the mCherry transgene in stable lines generated from the 4xCys (n=3) and TM7 (n=2) constructs was examined. Brood size and percentage transmission of extrachromosomal array is shown in Table 3.14.

Transgenic strain from 4xCys and TM7 transmit the transgene to adult offspring at between 98-100%. Strain DA 201 that transmits 100% was tested for the integration of extrachromosomal array using similar approach as described in Section 3.4.1. The result showed that extrachromosomal array was integrated in this strain (data not shown).

### Section 3.5.2.1.2 Effect of C-terminally truncated *lat-1a* in *lat-1*(ok1465) worms

#### Section 3.5.2.1.2.1 Developmental lethality effect

To examine developmental lethality, embryos from transgenic animals and the number of embryos surviving to adulthood were determined, for wild-type worms, *lat-1*(ok1465) worms and the transgenic worms. The transgenic strains with highest percentage of transmission were ex-

**Table 3.15 Effect of C-terminal *lat-1* gene on *lat-1*(ok1465) phenotypes.**

Genotype	No of embryos	Brood size	Defecation cycle (s)	Adults assayed (n)
Wild-type	301±10	301±10	45±9	10
<i>lat-1</i> (ok1465) worm	217±5	3±5 <sup>b</sup>	80±6 <sup>b</sup>	10
Strain DA 201 (4xCys)	223±15	223±15 <sup>b</sup>	47±10 <sup>b</sup>	15
Strain DA 302 (TM7)	218±12	20±7 <sup>b</sup>	57±6 <sup>b</sup>	10

Strain DA 201 and DA 301 from *lat-1*(ok1465) worms that were transgenic for 4xCys and TM7 constructs were examined for phenotypes respectively. The table shows the Mean±Standard deviation of brood sizes (defined as surviving adult progeny) and defecation cycle (measured in seconds). The genotype include wild-type, *lat-1*(ok1465) worm, strain DA 201 (4xCys), strain DA 302 (TM7), all examined at 20°C. Brood sizes of transgenic animals and *lat-1*(ok1465) worms were compared relative to wild-type level. P values were calculated between *lat-1* (ok1465) worms and wild-type, and strain DA 201 (4xCys), strain DA 302 (TM7) and *lat-1* (ok1465) worm and P<0.05 is indicated (<sup>b</sup>). n is the number of adult assayed

amined. From *lat-1(ok1465)* worms, only 3 adult offspring per animal reached adulthood (Table 3.15). Wild-type worms produced  $301 \pm 10$  adult offspring per animal. The 4xCys transgenic animals had  $223 \pm 15$  embryos, with 100% survival to adulthood ( $P < 0.0001$ , compared to *lat-1*). The *lat-1(ok1465)* worms transgenic for TM7 produced  $20 \pm 7$  adult offspring per animal from  $218 \pm 12$  ( $P < 0.0001$ , compared to *lat-1*). Further analysis of offspring lethality from TM7 transgenic animal gave rise to; 153/218 (70%) larval lethality and 45/218 (21%) embryo lethality out of 218 embryos ( $n=10$ ).

The result shows that the 4xCys construct on *lat-1(ok1465)* worms shows complete rescue of lethality, but the number of embryos laid is unchanged from *lat-1* worms. However, the TM7 construct on *lat-1(ok1465)* worms shows only a partial rescue of phenotype, but still > 6-fold above *lat-1* worms. Therefore, the 4xCys construct rescued the phenotype of *lat-1(ok1465)* worms, and partial rescue of the phenotype of *lat-1 (ok1465)* worms by the TM7 construct was noted, with offspring lethality during embryonic and larval stage. However, the full-length *lat-1a* showed > 300 offspring for the rescue of *lat-1* animal's brood size, and 4xCys showed 223 offspring. Thus the region after the 4xCys motif is important for rescuing the brood size defect.

#### **Section 3.5.2.1.2.2 Defecation cycle effect in *lat-1 (ok1465)* worms**

Defecation cycles were measured for the 4xCys and TM7 transgenes in *lat-1 (ok1465)* worms and also in wild-type and *lat-1 (ok1465)* worms. The *lat-1(ok1465)* worms shows significantly lengthened defecation cycle ( $80 \pm 6$  seconds) compared to wild-type animal ( $45 \pm 9$ ,  $P < 0.0001$ ). Transgenic *lat-1(ok1465)* animals with the 4xCys or TM7 constructs show a significantly reduced defecation cycle compared to *lat-1(ok1465)* worms ( $47 \pm 10$ ,  $P < 0.0001$  or  $57 \pm 6$ ,  $P < 0.0001$ ). These two domains of truncated C-terminus *lat-1a* cDNA show almost similar level of defecation cycle to the wild-type animal. Surprisingly, the TM7 construct rescued the defecation cycle defect, in contrast to its inability to rescue the lethality of *lat-1(ok1465)* worms.

Thus, the 4xCys domain is dispensable for complementation of the defecation cycle defect, but required for the rescue of developmental lethality in the *lat-1(ok1465)* worms.

### Section 3.5.2.2 Role of the *lat-1a* N-terminus

The N-terminus of GPCR proteins is believed to be responsible for binding ligands, and the se-

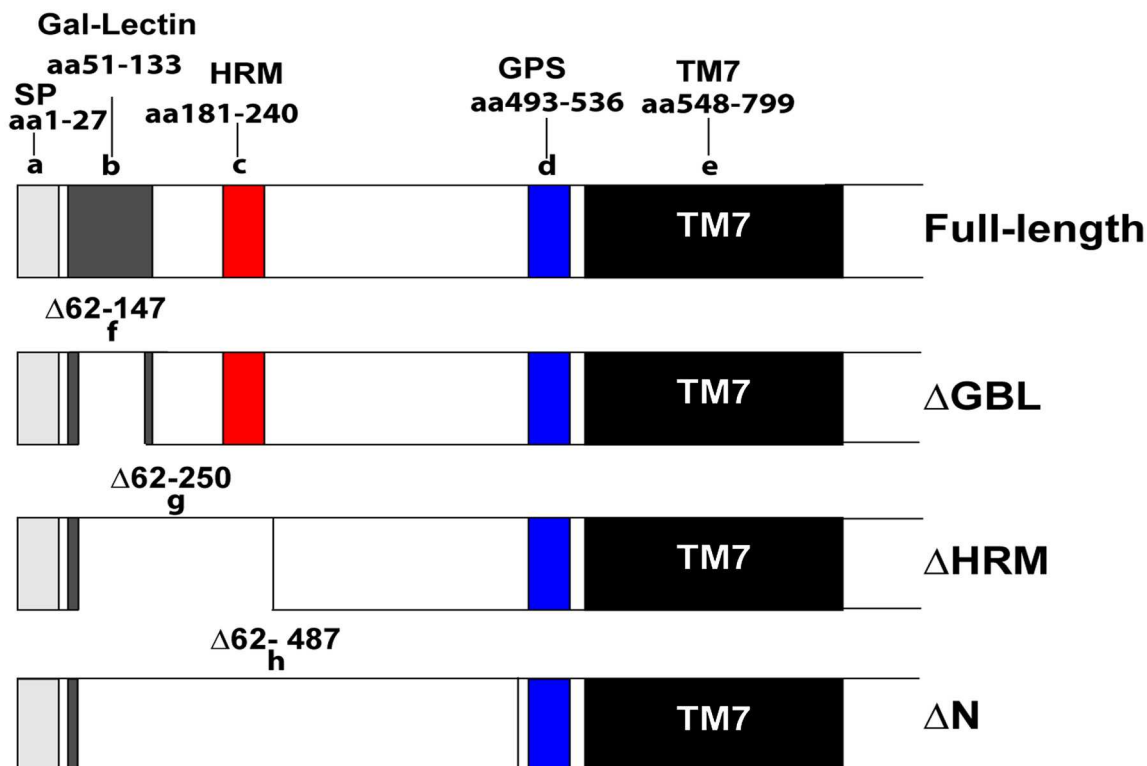

**Figure 3.12 Cartoon depicting deletion of N-terminal *lat-1a* cDNA.** The first structure shows the full-length N-terminal *lat-1a* cDNA having five functional domains with their relative amino acid positions: (a) Signal peptide (SP) in gray colour has amino acid position at between 1-27, (b) Galactose-binding lectin domain in dark gray colour has amino acid positions at between 51-133, (c) Hormone receptor motif domain (HRM) in red colour has amino acid positions at between 181-240, (d) G-protein coupled receptor proteolysis site (GPS) in blue colour has amino acid positions at between 493-536, (e) Seven transmembrane domain (TM7) in black colour has amino acid positions at between 548-799. (f) The Galactose-binding lectin domain ( $\Delta$ GBL) shows truncation of domains at amino acids between  $\Delta$ 62-147. (g) The Hormone receptor motif domain ( $\Delta$ HRM) shows truncation of domain at amino acid between  $\Delta$ 62-250. (h) The N-terminal ( $\Delta$ N) deletion construct shows deletion between amino acids  $\Delta$ 62-487.

cretin family of GPCRs has a large N-terminal region; it is not clear what regions are involved in binding any endogenous ligand. Hence, it is important to investigate N-terminal *lat-1a* truncations to determine which regions are necessary for the rescue of *lat-1(ok1465)* worms. Three different constructs were generated, and all three contained amino acids 1-61, which includes the putative N-terminal signal peptide which is likely required for correct processing and trans-

port of the protein to the cell surface. The first construct has a deletion of the galactose-binding lectin domain (amino acids 62-147 “ $\Delta$ GBL”); the second additionally deletes the hormone receptor motif domain (amino acids 62-250 “ $\Delta$ HRM”); and the third deletes the rest of the N-terminal domain up to the GPS (amino acids 62-487 “ $\Delta$ N”) (Figure 3.12). Using the same approach as for the C-terminal deletion series, all clones were translationally fused in-frame at the C-terminus to GFP and placed under the control of  $\sim$ 1.5kb of the endogenous *lat-1* promoter. The plasmids are designated as  $\Delta$ GBL [ $P_{1.5\text{kb } lat-1}::\Delta$ GBL(*lat-1a* cDNA)::*gfp*] or [pAA404];  $\Delta$ HRM [ $P_{1.5\text{kb } lat-1}::\Delta$ HRM(*lat-1a* cDNA)::*gfp*] or [pAA405]; and  $\Delta$ N [ $P_{1.5\text{kb } lat-1}::\Delta$ N(*lat-1a* cDNA)::*gfp*] or [pAA408]. Each individual N-terminal truncation was examined for the rescue of *lat-1(ok1465)* worms. Individual constructs were co-injected with the selectable marker, mCherry, into *lat-1(ok1465)* worms, while the selectable marker was injected into *lat-1(ok1465)* worms as a negative control.

The  $\Delta$ GBL construct produced two independent stable lines from three different injected  $F_0$  worms and  $\Delta$ HRM construct produced one independent stable line from three different injected  $F_0$  worms,  $\Delta$ N construct did not yield any independent stable line from three different injected  $F_0$  worms.

In the negative control, four different injected  $F_0$  worms with mCherry construct produced mCherry red fluorescent embryos with two transgenic  $F_1$  reaching adulthood but failed to produce transgenic offsprings (Table 3.16). Chi-squared test analysis ( $\chi^2$ ) was used to determine statistical significance of the difference in proportion of embryos that reached adulthood after injection of each construct or selectable marker. The result was found to be statistically significant for  $\Delta$ GBL construct or  $\Delta$ HRM construct but not significantly different for  $\Delta$ N construct. Hence, the deletion of galactose-binding lectin domain or hormone motif receptor domain retained the ability of the construct to partially rescue the lethality of *lat-1(ok1465)* worms, while



deletion of the rest of the N-terminal domain abolished the ability of the construct to rescue the lethality of *lat-1(ok1465)* worms.

**Table 3.16 Effect of N-terminal *lat-1* gene and mCherry DNA on *lat-1* (*ok1465*) worms.**

DNA injected	Transgenic embryo (F <sub>1</sub> )	Transgenic adult (F <sub>1</sub> )	Stable transgenic line
[P <sub>1.5kb lat-1</sub> ::ΔGBL( <i>lat-1a</i> cDNA):: <i>gfp;unc-54::mCherry</i> ][pAA404;pAA414]	32	18	12
	27	13	6
	15	5	0
Total	74 <sup>a</sup>	36 <sup>a</sup>	18
[P <sub>1.5kb lat-1</sub> ::ΔHRM( <i>lat-1a</i> cDNA):: <i>gfp;unc-54::mCherry</i> ][pAA405;pAA414]	23	11	6
	14	5	0
	16	7	0
Total	53 <sup>b</sup>	23 <sup>b</sup>	6
[P <sub>1.5kb lat-1</sub> ::ΔN( <i>lat-1a</i> cDNA):: <i>gfp;unc-54::mCherry</i> ][pAA408;pAA414]	21	1	0
	25	1	0
	18	0	0
Total	64 <sup>c</sup>	2 <sup>c</sup>	0
[ <i>unc-54::mCherry</i> ] [pAA414]	25	2	0
	17	0	0
	16	1	0
Total	58 <sup>d</sup>	3 <sup>d</sup>	0

DNA from each construct as described in Table 3.16 was injected into the syncytial gonad of *lat-1(ok1465)* worms at a concentration of 50-100μg/ml. Transgenic offspring obtained were studied for the presence of red fluorescence in the body-wall muscle. The number of transgenic embryos, transgenic adults and stable transgenic lines from each injected animal is shown. The statistical significance of the proportion of transgenic worms surviving to adulthood between ΔGBL construct, ΔHRM construct, ΔN construct and mCherry construct was determined by a chi squared test, and the difference between <sup>a</sup> & <sup>d</sup>, <sup>b</sup> & <sup>d</sup> was found to be significant (P<0.05), whereas there was no significant difference between <sup>c</sup> & <sup>d</sup> (P=0.5847).

### Section 3.5.2.3 Stability of mCherry transgene in transgenic worms

Stable lines were examined for percentage of transmission. The stable lines DA 401 and 402 of

$\Delta$ GBL transmit mCherry to progeny at between 98-99%. The hormone receptor motif yielded one strain DA 501, and transmits mCherry to progeny at 98% as shown in Table 3.17. The result shows that transgenic stable lines from  $\Delta$ GBL and  $\Delta$ HRM transmit mCherry to a high percentage of their adult offspring.

**Table 3.17 The mCherry transgene of N-terminal lat-1a cDNA stability.**

Stable transgenic strain	% transmission (Cherry)	Brood size	Adults assayed (n)
[P <sub>1.5kblat-1</sub> :: $\Delta$ GBL(lat-1a cDNA):: <i>gfp;unc-54::mCherry</i> ][pAA404;pAA414]			
DA 401	98%	87±17	15
DA 402	99%	96±9	15
[P <sub>1.5kblat-1</sub> :: $\Delta$ HRM(lat-1a cDNA):: <i>gfp;unc-54::mCherry</i> ][pAA405;pAA414]			
DA 501	98%	25±6	15

Transgenic strain from each tested stable line was examined for percentage of transmission and brood size as shown in the Table 3.17. The percentage of transmission with mCherry plasmid is the number of transgenic adult animal that reached adulthood with red fluorescence. Brood size is the total number of transgenic adult per individual animal (Mean ± Standard). n is the number of adult transgenic animal assayed for the study.

### Section 3.5.2.4 Effect of N-terminal deletions in lat-1 (ok1465) worms

#### Section 3.5.2.4.1 Effect on developmental lethality of lat-1 (ok1465) worms

To study developmental lethality, transgenic worms carrying either  $\Delta$ GBL or  $\Delta$ HRM constructs were examined for embryonic survival. The lat-1(ok1465) worms produced only 3 offspring per

**Table 3.18 Effect of N-terminal lat-1a cDNA on lat-1(ok1465) phenotypes.**

Genotype	No of embryos	Brood sizes	Defecation cycle (s)	Adults assayed (n)
Wild-type	296±13	296±13	45±3	10
lat-1(ok1465) worm	230±6	3±2 <sup>b</sup>	80±8 <sup>b</sup>	10
Strain DA 402 ( $\Delta$ GBL)	250±11	96±9 <sup>b</sup>	48±9 <sup>b</sup>	15
Strain DA 501 ( $\Delta$ HRM)	192±4	25±6 <sup>b</sup>	50±12 <sup>b</sup>	15

Strain DA 402 and DA 501 from transgenic worms carrying  $\Delta$ GBL and  $\Delta$ HRM constructs respectively were examined for phenotypes. Table 3.18 shows the Mean±Standard deviation of brood sizes (defined as surviving adult progeny) and defecation cycle (measured in seconds) of all genotypes; Wild-type, lat-1(ok1465) worm, strain DA 402 ( $\Delta$ GBL) strain DA 501 ( $\Delta$ HRM) assayed at 20°C. Brood sizes were measured relative to wild-type level. P values were calculated between lat-1 (ok1465) worm and Wild-type, and between strain DA 402 ( $\Delta$ GBL) and lat-1(ok1465) worm, strain DA 501 ( $\Delta$ HRM) and lat-1(ok1465) worm and P<0.05 is indicated (<sup>b</sup>). n is the number of adult assayed.

animal that survived to adulthood (Table 3.18), whereas wild-type worms produced  $296 \pm 13$  adult offspring per animal. The number of embryos laid by *lat-1(ok1465)* worms had a 22% reduction ( $230 \pm 6$ ;  $P < 0.0001$ ), significantly different from wild-type worms.

The  $\Delta$ GBL on *lat-1(ok1465)* worms produced  $250 \pm 11$  embryos per animal, which was close to *lat-1*, and the number of surviving adult offspring was significantly increased compared to *lat-1*. 250 embryos were examined from strain 402 for offspring lethality gave rise to; 53/250 (21%) embryo lethality and 100/250 (40%) larval lethality ( $n=15$ ). The  $\Delta$ HRM on *lat-1(ok1465)* worms produced  $192 \pm 4$  embryos per animal, which was significantly lower than *lat-1* worms, and the number of surviving adult offspring was  $25 \pm 6$ , significantly greater than in *lat-1* worms. Out of 192 embryos examined from strain 501, the result yielded; 67/192 (35%) embryo lethality and 100/192 (52%) larval lethality ( $n=15$ ). The  $\Delta$ GBL and  $\Delta$ HRM on *lat-1(ok1465)* worms only show partial rescue of phenotype, since the rescue is smaller than the levels seen in wild-type worms.

However, the effect of the  $\Delta$ GBL locus in rescuing lethality is greater than the  $\Delta$ HRM construct, as the number of adult offspring are  $\sim 4$ -fold higher. The deletion of the HRM domain in  $\Delta$ HRM causes a substantial decrease in the ability to complement the lethality during embryonic and larval stage in *lat-1(ok1465)* worms and, therefore, this domain has an essential role in the endogenous function of the *lat-1* receptor.

#### **Section 3.5.2.5 Effect of N-terminal truncations on defecation cycle**

Defecation cycles were measured for the  $\Delta$ GBL or  $\Delta$ HRM worms on *lat-1(ok1465)*, and compared with wild-type and *lat-1(ok1465)* worms. The *lat-1(ok1465)* worms shows a significantly prolonged defecation cycle, compared to wild-type worms. *Lat-1(ok1465)* worms that were transgenic for both  $\Delta$ GBL and  $\Delta$ HRM had a reduced defecation cycle compared to the *lat-1(ok1465)* animals. Transgenic worms from these two domains of truncated N-terminal *lat-1a*

cDNA nearly show the same level of defecation cycle as wild-type worms. Surprisingly, the  $\Delta$ GBL and  $\Delta$ HRM constructs rescued the defecation cycle defect in lat-1(ok1465) worms, despite their inability to rescue the lethality in these worms. Therefore, these data show that neither the galactose-binding lectin or hormone receptor motif domains of lat-1a are required to rescue the defecation cycle in lat-1(ok1465) worms.

### **Section 3.6 Is TM1 a dominant negative?**

A hypothesis is that TM1 would decoy any endogenous ligand from binding to the endogenous receptor, thus attenuating the endogenous signalling pathway; binding of ligand to the TM1 protein will result in no intracellular signalling. This hypothesis predicts that the TM1 construct will produce a mild phenocopy of the lat-1(ok1465) phenotype if injected into N2 worms, therefore, acting as a dominant negative. By contrast, although the  $\Delta$ N N-terminal deletion mutant yielded no stable lines when injected into lat-1 worms, it does not have a functional ligand-binding domain, and would be predicted to have no adverse effects if injected into N2 worms.

To test this hypothesis, the TM1 plasmid or  $\Delta$ N plasmid was injected into wild-type worms. The selectable marker mCherry plasmid and full-length lat-1a cDNA were injected into wild-type worm as negative controls. Three different injected  $F_0$  worms produced three independent stable lines each from co-injection of TM1 and mCherry plasmids, the  $\Delta$ N and mCherry plasmids. Four different injected  $F_0$  worms produced stable lines from co-injection of full-length lat-1a cDNA and mCherry plasmids, while injection of mCherry plasmid only produced three stable lines from three injected  $F_0$  worms. The statistical significance of the difference in the proportion of transgenic embryos that reached adulthood after injection of TM1 plasmid,  $\Delta$ N plasmid, full-length lat-1a cDNA plasmid, or selectable marker, was calculated by  $\chi^2$  analysis.

The result shows a statistically significant difference in the number of transgenic embryos surviving until adulthood between animals transgenic for TM1 plasmid and animals transgenic for

either mCherry plasmid or full-length lat-1a plasmid, whereas there was no statistically signif-

**Table 3.19 Effect of TM1 lat-1a cDNA and mCherry DNA on wild-type worms.**

DNA injected	Transgenic embryo (F1)	Transgenic adult (F1)	Stable transgenic line
[P <sub>1.5kblat-1</sub> ::FL(lat-1a cDNA):: <i>gfp;unc-54::mCherry</i> ][pAA401;pAA414]	40	40	28
	28	28	17
	34	34	21
	25	25	12
Total	127 <sup>a</sup>	127 <sup>a</sup>	78
[P <sub>1.5kblat-1</sub> ::TM1(lat-1a cDNA):: <i>gfp;unc-54::mCherry</i> ] [pAA407;pAA414]	22	11	6
	19	9	8
	25	13	10
Total	66 <sup>b</sup>	33 <sup>b</sup>	9
[P <sub>1.5kblat-1</sub> ::ΔN(lat-1a cDNA):: <i>gfp;unc-54::mCherry</i> ][pAA408;pAA414]	25	25	11
	22	22	8
	27	27	13
Total	74 <sup>c</sup>	74 <sup>c</sup>	32
[ <i>unc-54::mCherry</i> ] [pAA414]	28	28	14
	19	19	10
	25	25	11
Total	72 <sup>d</sup>	72 <sup>d</sup>	35

The syncytial gonad of wild-type worms was injected with plasmid DNA at a concentration of 50-100μg/ml. Transgenic offspring were identified by the presence of red fluorescence in body wall. Table 3.19 shows the number of transgenic embryos, transgenic adults and stable transgenic lines from injection of each construct. The statistical significance of the proportion of transgenic worms surviving to adulthood between <sup>a</sup> & <sup>b</sup>, <sup>b</sup> & <sup>c</sup>, <sup>b</sup> & <sup>d</sup> was found to be significant (P<0.05). While the difference between <sup>a</sup> & <sup>d</sup>, <sup>a</sup> & <sup>c</sup>, <sup>c</sup> & <sup>d</sup> was found not be significant (P>0.05) ( $\chi^2$  analysis)

icant difference between full-length lat-1a cDNA plasmid and mCherry plasmid or with ΔN plasmid and mCherry plasmid. This result shows that the TM1 construct had a statistically significant effect, decreasing viability of wild-type worms by ~ 50%, as reflected in the number of the transgenic embryo that reached adulthood. The effect on wild-type worms is not as a result

of full-length *lat-1a* plasmid,  $\Delta N$  plasmid or mCherry plasmid, but TM1 specific. However, the effect of truncated TM1 *lat-1a* construct on wild-type strengthens the hypothesis that TM1 might be decoying ligand from binding to endogenous receptors, given a reduction in the number of transgenic embryos that survived to adulthood.

### Section 3.6.1 Transmission of mCherry transgene

The percentage transmission of mCherry was studied in the transgenic lines generated in Section 3.5.2. At least three independent stable lines were generated from each construct. Each sta-

**Table 3.20 The mCherry transgene of TM1 *lat-1a* cDNA stability .**

Stable transgenic strain	% transmission (mCherry)	Brood size	Adults assayed (n)
<i>[P<sub>1.5kblat-1</sub>::FL(<i>lat-1a</i> cDNA)::gfp;unc-54::mCherry][pAA401;pAA414]</i>			
DA701	88%	266±16	10
DA702	73%	217±23	10
DA703	59%	195±15	10
DA704	67%	189±13	10
<i>[P<sub>1.5kblat-1</sub>::TM1(<i>lat-1a</i> cDNA)::gfp;unc-54::mCherry] [pAA407;pAA414]</i>			
DA801	59%	58±9	10
DA802	62%	62±12	10
DA803	75%	82±21	10
<i>[P<sub>1.5kblat-1</sub>::<math>\Delta N</math>(<i>lat-1a</i> cDNA)::gfp;unc-54::mCherry][pAA408;pAA414]</i>			
DA901	55%	143±5	10
DA902	67%	183±14	10
DA903	70%	202±10	10
<i>[unc-54::mCherry] [pAA414]</i>			
DA911	85%	242±17	10
DA912	67%	205±11	10
DA913	71%	202±8	10

Stable transgenic strains were obtained from independent stable lines for individual injection of each constructs as described in Table 3.20. The percentage of transmission was measured for the transgenic adult offspring that transmits mCherry (red-fluorescence) only. Brood size is the total number of transgenic offspring per individual animal (Mean±Standard deviation). n is the number of adult transgenic animal assayed for the study.

ble line, where tested, yielded one strain per individual construct, as named in the Table 3.20, and the strains transmit mCherry to progeny at 55-88%. All the stable transgenic strains were examined for brood size and the percentage of transmission .

The result shows that the stable lines obtained from individual constructs differ from one another as indicated by the percentage of transmission and brood sizes.

### **Section 3.6.2 Phenotypic effects of TM1 on wild-type worms**

#### **Section 3.6.2.1 Developmental effect of TM1**

The effect of the TM1,  $\Delta N$  and full-length lat-1a constructs or the selectable marker on wild-type animals were measured for developmental lethality. Developmental lethality was measured from the transgenic lines with the highest percentage of transmission. N2 worms produced  $292 \pm 12$  adult offspring per animal. Transgenic worms carrying a truncated TM1 construct showed a significant reduction ( $\sim 57\%$ ) in the number of embryos laid, at  $160 \pm 9$  per adult animal ( $P < 0.0001$ , compared to wild-type), and the number of surviving adult offspring was  $82 \pm 21$  ( $P < 0.0001$ , compared to wild-type). The phenotype of TM1 transgenic worm is characterised by failure of elongation during embryogenesis and rupture of intestine during larval development. Analysis of 160 embryos from strain DA 803 for offspring lethality showed 50/160 (31%) larval lethality and 28/160 (18%) ( $n=10$ ). A typical example of embryo or larval arrest is shown in Figure 3.13.

The data showed no decrease in the number of embryos laid or the number of offspring that reached adulthood from wild-type worms that were transgenic for  $\Delta N$ , full-length lat-1a construct or the selectable marker. Hence, these data showed that truncation of C-terminal of lat-1a to TM1 is toxic to wild-type worms which had significant offspring lethality, and this is consistent with toxicity to transgenic embryos from micro-injection of TM1 construct into lat-1(ok465) worms, observed in Section 3.5.2.1. Also, the nature of toxicity shown in Figure 3.13

is similar to the phenotypes of *lat-1(ok1465)* worms in Figure 3.3.

**Table 3.21 Effect of TM1 *lat-1a* cDNA on wild-type phenotypes.**

Genotype	No of embryos	Brood size	Defecation cycle (s)	Adults assayed (n)
Wild-type	292±12	292±12	45±14	10
Strain DA 701 (Full-length )	297±23	297±23 <sup>b</sup>	47±5 <sup>b</sup>	10
Strain DA 803 (TM1)	160±9	82±21 <sup>b</sup>	71±4 <sup>b</sup>	10
Strain DA 903 (ΔN)	284±7	284±7 <sup>b</sup>	45±8 <sup>b</sup>	10
Strain DA 911 (mCherry)	285±11	285±11 <sup>b</sup>	44±13 <sup>b</sup>	10

Strain DA 701, 803, 903, 911 (genotypes) were obtained from wild-type animals that were transgenic for full-length, TM1, ΔN, mCherry construct respectively. The table depicts the Mean±Standard deviation of brood sizes (defined as surviving adult progeny) and defecation cycle (measured in seconds). Brood sizes were measured relative to wild-type. P values were calculated between wild-type and strain DA 701 (P>0.05) , wild-type and strain DA 803 (TM1) (P<0.05), wild-type and strain DA 903 (ΔN) (P>0.05) , wild-type and mCherry ( P>0.05). P value is indicated (<sup>b</sup>). n is the number of adult assayed

However, the ΔN and full-length *lat-1a* constructs gave transgenic lines which had brood sizes and offspring survival that was not significantly different from the mCherry transgenic lines. The fact that the full-length construct does not cause toxicity excludes the possibilities that the *lat-1* is toxic or that the promoter is driving inappropriate temporal or tissue-specific expression that causes toxicity. Moreover, the finding that the ΔN plasmid transgenic animals are not compromised shows that a dysfunctional *lat-1* is not sufficient for the toxicity. Therefore, it is a good evidence for decoying of ligand from endogenous receptors.

### Section 3.6.2.2 Effect of TM1 *lat-1a* cDNA on defecation cycle in wild-type worms

Defecation cycles were measured for the individual constructs, and compared with wild-type animals. Wild-type worms show a defecation cycle period of 45±14 seconds. But, wild-type animals that were transgenic for TM1 construct shows a prolonged defecation cycle ( 71±4 seconds), significantly greater compared to wild-type worm (P=0.0018). The full-length *lat-1a* construct in wild-type worms shows a defecation cycle of 47±5 seconds. The ΔN transgenics has a defecation cycle of 45±8 seconds and the selectable marker on wild-type worms shows a



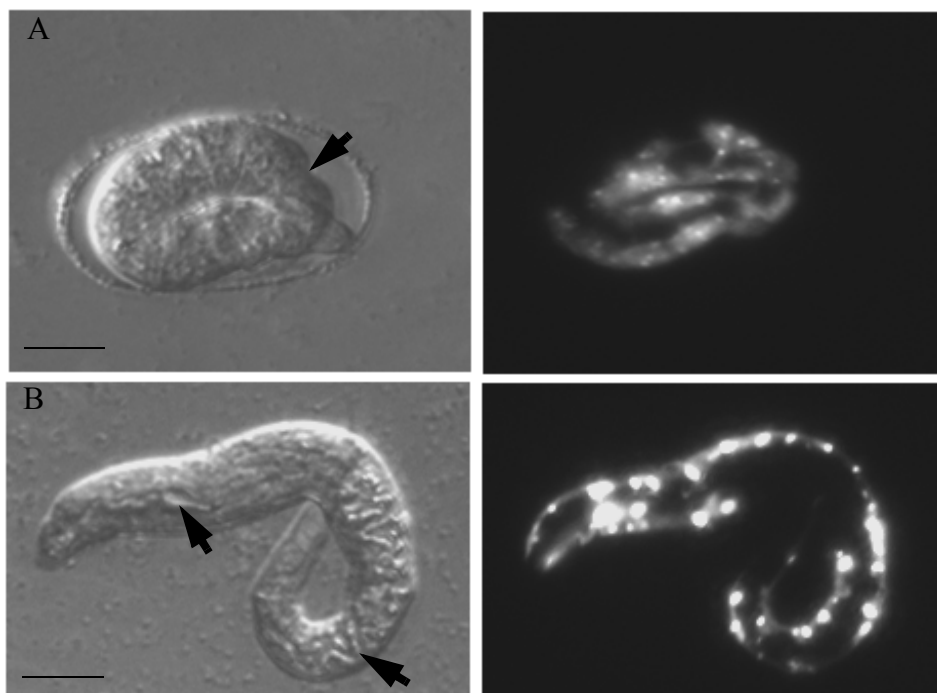

**Figure 3.13 Phenotypes of TM1 *lat-1a* cDNA on wild-type worms.** The diagram shows the photographs of arrested embryo and larvae from transgenic animal carrying N2 [ $P_{1.5\text{kb } lat-1}::TM1(lat-1a \text{ cDNA})::gfp;unc-54::mCherry$ ] [pAA407;pAA414]. All images were captured under DIC optics and mCherry filter using the same focal point at 100x magnification. Embryos were dissected from transgenic adult hermaphrodite as described in section 2.8.1. **A** is a typical example of 3-fold stage arrested embryo that failed to elongate as indicated by the arrow. **B** is a typical example of larval 1 with the rupture of intestine and pharynx as shown by the arrow. Scale bar is 50  $\mu\text{m}$ .

defecation cycle of  $44 \pm 13$  seconds; none of which are significantly different from wild-type. These data show that the TM1 construct on wild-type worm caused a significant lengthening of the defecation cycle, whereas there was no effect in the wild-type animals that were transgenic for  $\Delta N$  construct, full-length *lat-1a* or selectable marker.

Since the  $\Delta N$  construct was not toxic to wild-type worms, the failure of the  $\Delta N$  construct to rescue *lat-1(ok1465)* worms demonstrates that  $\Delta N$  construct merely lacks the ability to rescue *lat-1(ok1465)* worms, but is not toxic to these worms per se. Moreover, micro-injection of full-length *lat-1a* or selectable marker had no toxic effect on wild-type worms, showing that the *lat-1a* sequence by itself (or the mCherry) has no gross toxicity in wild-type worms. It is therefore concluded that, truncation of C-terminus of *lat-1a* to transmembrane domain one is toxic and

acts as dominant negative as predicted, and prevents ligand from binding to endogenous lat-1 gene in wild-type worms.

## Section 3.7 Tissue-specific expression of lat-1a

### Section 3.7.1 *aex-3* promoter driving lat-1a expression

The ~1.5kb *lat-1* promoter driving a full-length *lat-1a* cDNA construct rescues *lat-1(ok1465)* worms. It is known that the mammalian latrophilin is expressed at high level in the nervous system. Therefore, it was proposed to express *lat-1a* cDNA constitutively in nerve cells by replacing the *lat-1* promoter with the *aex-3* promoter, which has been shown to mediate nerve-specific expression [100]. To study this, the full-length *lat-1a* cDNA containing exon 1 and exon 2 with intron was translationally fused in-frame to C-terminal of GFP and driven by ~1.3kb of the *aex-3* promoter; this plasmid is the *aex-3* reporter construct; [P<sub>1.3kb aex-3</sub>::FL(*lat-1a* cDNA)::*gfp*] designated as [pAA409] (Figure 3.4).

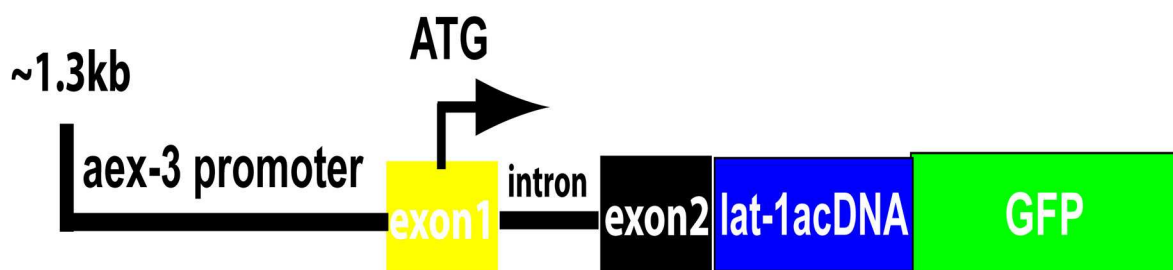

**Figure 3.14** Translational reporter gene fusion of *lat-1a* cDNA driven by *aex-3* promoter. Cartoon shows in-frame translational fusion of *lat-1a* cDNA to reporter gene. ~1.3kb, 5' end of *aex-3* promoter contains start codon ATG (black arrow) in the middle of exon 1 (yellow) with an intron (black line) and exon 2 (black box) with *lat-1a* cDNA (blue box) fused to green fluorescent protein GFP (green box), resulting construct is designated as pAA409. ( see section 2.10.3)

The primary aim of this experiment was to find out if *aex-3* promoter, driving nerve-specific expression, could rescue the lethality of *lat-1 (ok1465)* worms, as this would suggest an important role for latrophilin in the nervous system. The *aex-3* reporter construct was co-injected with mCherry as a selectable marker into *lat-1 (ok1465)* worms and mCherry was injected into *lat-1 (ok1465)* worms as a negative control.

**Table 3.22** Effect of *aex-3* reporter construct and mCherry DNA on *lat-1* (ok1465) worms.

DNA injected	Transgenic embryo (F <sub>1</sub> )	Transgenic adult (F <sub>1</sub> )	Stable Transgenic line
P <sub>1.3kb aex-3::FL(lat-1a cDNA)::gfp;</sub> <i>unc-54::mCherry</i> [pAA409;pAA414]	25	2	0
	18	1	0
	30	4	0
	23	3	0
Total	96 <sup>a</sup>	10 <sup>a</sup>	0
<i>unc-54::m-Cherry</i> [pAA414]	24	2	0
	14	0	0
	10	1	0
	16	2	0
Total	64 <sup>b</sup>	5 <sup>b</sup>	0

The plasmid DNA from *aex-3* reporter construct or mCherry was injected into the syncytial gonad of *lat-1*(ok1465) worms at a concentration of 50-100µg/ml. Transgenic offspring obtained were examined for the presence of red fluorescence in the body wall. The number of transgenic embryos, transgenic adults and stable transgenic lines from each injected animal are presented in the Table 3.22. The statistical significance of the proportion of transgenic worms surviving to adulthood between *aex-3* reporter construct and mCherry was determined by a Chi squared test, and the difference between <sup>a</sup> and <sup>b</sup> was found not to be significant (P>0.05)

The transgenic worms were identified by red-fluorescent body-wall muscle expression from embryogenesis to adulthood. Micro-injection of *aex-3* reporter construct produced red fluorescent embryos from four different injected F<sub>0</sub> worms with ten transgenic F<sub>1</sub> reaching adulthood without producing transgenic progeny. In the negative control experiment, four different injected F<sub>0</sub> worms with mCherry produced red fluorescent embryos from four different injected worms with five transgenic F<sub>1</sub> reaching adulthood but failed to produce transgenic offspring (Table 3.22).

The statistical significance of difference in proportion of transgenic embryos that reached adulthood after injection of *aex-3* reporter construct or selectable marker was calculated by Chi-squared method, and found not to be statistically significant (P=0.78). The result shows

that when fusion protein was driven by *aex-3* promoter, it failed to rescue the lethality of *lat-1(ok1465)* worms. This could be explained either by a failure of the *aex-3* promoter to confer expression in a tissue relevant for the lethality, or by expression of *lat-1* in an inappropriate tissue causing lethality.

### Section 3.7.2 Effect of *aex-3* reporter construct on wild-type worms

Micro-injection of *aex-3* reporter construct could not rescue the lethality of *lat-1 (ok1465)* worms, but produced ten transgenic adults F<sub>1</sub> without transgenic offspring. Thus, it was not possible to study the inappropriate expression of *lat-1*. A hypothesis is that *aex-3* promoter might drive tissue-specific expression that causes toxicity. It is important to test effect of *aex-3* reporter construct on wild-type worms and study the resulting offsprings for any toxic effect. The *aex-3* reporter construct was co-injected with mCherry, while mCherry, the selectable marker was injected as a negative control.

**Table 3.23 Effect of *aex-3* reporter construct and mCherry DNA on wild-type worms.**

DNA injected	Transgenic embryo (F <sub>1</sub> )	Transgenic adult (F <sub>1</sub> )	Stable transgenic line
P <sub>1.3kb aex-3</sub> ::FL( <i>lat-1a</i> cDNA):: <i>gfp</i> ; <i>unc-54</i> :: <i>mCherry</i> [pAA409;pAA414]	23	23	12
	18	18	9
	29	29	10
Total	70 <sup>a</sup>	70 <sup>a</sup>	31
<i>unc-54</i> :: <i>mCherry</i> [pAA414]	27	27	14
	15	15	7
	33	33	17
Total	75 <sup>b</sup>	75 <sup>b</sup>	38

The plamid DNA from each construct was injected into the syncytial gonad of N2 worms at a concentration of 20-50µg/ml. Transgenic offspring obtained were examined for the presence of red fluorescence in the body wall. Table 3.23 shows the number of transgenic embryos, transgenic adults and stable transgenic lines. The statistical significance of the proportion of transgenic worms surviving to adulthood between *aex-3* reporter construct and *mCherry* was determined by a Chi squared test, and the difference between <sup>a</sup> and <sup>b</sup> was found not to be significant (P>0.05)

Three independent stable lines were obtained from three different injected F<sub>0</sub> worms with *aex-3* reporter construct. The injection of selectable marker produced three independent stable lines

from three different injected F<sub>0</sub> worms. The  $\chi^2$  method was used to calculate the statistical significance of difference in proportion of transgenic embryos that reached adulthood after injection of *aex-3* reporter construct or selectable marker, and this was found not to be statistically significant. These data were not sufficient to characterise the effect of *aex-3* reporter construct. Therefore, further characterisation of independent stable lines should define the roles of *aex-3* reporter construct or selectable marker on wild-type worms.

### Section 3.7.3 Stability of mCherry transgene of *aex-3* reporter construct on wild-type

Wild-type worms that were transgenic for *aex-3* reporter construct or selective marker were examined for stability. One strain was tested from either *aex-3* reporter construct or selectable marker, and the strains transmit mCherry to progeny at between 39%-77%. All the stable transgenic strains were studied for brood size and percentage of transmission.

**Table 3.24 The mCherry transgene of *aex-3* reporter construct stability.**

Stable transgenic strain	% transmission (mCherry)	Brood size	Adults assayed (n)
[P <sub>1.3kb aex-3</sub> ::FL(lat-1a cDNA):: <i>gfp;unc-54::mCherry</i> ][pAA409;pAA414]			
DA 111	45%	75±11	10
DA 112	69%	118±7	10
DA 113	39%	66±4	10
<i>unc-54::mCherry</i> [pAA414]			
DA 914	75%	201±17	10
DA 915	58%	168±10	10
DA 916	77%	226±15	10

Stable transgenic strains were obtained from independent stable lines for individual injection of either *aex-3* reporter construct or selectable marker, mCherry. The percentage of transmission was measured for the transgenic adult offspring that transmits mCherry (red-fluorescence) only. Brood size is the total number of transgenic offspring per individual animal (Mean± Standard deviation). n is the number of adult transgenic animal assayed for the study.

These data show the level of stability of each strain differs from one another as indicated by the percentage of transmission of mCherry transgene and brood sizes. However, *aex-3* reporter construct shows relatively low percentage of transmission with smaller brood sizes.

### Section 3.7.4 Phenotypic effect of *aex-3* reporter construct and mCherry on wild-type

#### Section 3.7.4.1 Effect of *aex-3* construct on development

Embryos were counted from transgenic worms carrying *aex-3* reporter construct or mCherry to examine the developmental processes. Wild-type worms produced  $296 \pm 15$  offspring per adult animal. The *aex-3* reporter construct on wild-type worm shows a significantly reduced number of embryos laid per animal ( $170 \pm 18$ ;  $P < 0.0001$  compared to wild-type), and the number of surviving adults offspring per animal was  $170 \pm 18$  ( $P < 0.0001$ , compared to wild-type). However, mCherry on wild-type worms laid  $293 \pm 10$  embryos per adult animal ( $P = 0.24$ , compared to wild-type) and the number of surviving adult offspring per animal was  $293 \pm 10$  ( $P = 0.24$ , compared to wild-type). The result shows a great reduction in the number of offspring from transgenic animal carrying *aex-3* reporter construct. However, the result shows no decrease in the number of offspring from transgenic animal carrying mCherry. Thus, the *aex-3* construct causes a decrease in the brood size, but does not cause developmental lethality.

**Table 3.25** Effect of *aex-3* construct on wild-type worm phenotypes.

Genotype	No of embryos	Brood size	Defecation cycle (s)	Adults assayed (n)
Wild-type	$296 \pm 15$	$296 \pm 15$	$45 \pm 11$	10
Strain DA 112 ( <i>aex-3</i> reporter construct)	$170 \pm 18$	$170 \pm 18^b$	$85 \pm 6^b$	10
Strain DA 916 (mCherry)	$293 \pm 10$	$293 \pm 10^b$	$47 \pm 13^b$	10

Strain DA 112, 916 obtained from transgenic worms carrying *aex-3* reporter construct and mCherry plasmid respectively were studied for the phenotypes. The Mean  $\pm$  Standard deviation of the number of embryos, brood sizes (defined as surviving adult progeny) and defecation cycle (measured in seconds) were represented in the Table 3.25 for all genotypes, assayed at 20C. Brood sizes were compared combined latrotoxins combined latrotoxins relative to wild-type level. P values were calculated between wild-type and strain DA112 (*aex-3* reporter construct) ( $P < 0.05$ ), wild-type and strain DA 916 ( $P > 0.05$ ). P value is indicated (<sup>b</sup>), n is the number of adult assayed

#### Section 3.7.4.2 Effect of *aex-3* reporter construct on defecation cycle

Defecation cycles were measured for the *aex-3* reporter construct and *unc-54::mCherry* on wild-type worms. N2 worm shows a defecation cycle of  $45 \pm 11$  seconds. Transgenic worms carrying *aex-3* reporter construct shows a significantly prolonged defecation cycle ( $85 \pm 6$  seconds), compared to wild-type ( $P < 0.0001$ ), whereas wild-type worms that were transgenic for mCherry

shows a defecation cycle ( $47 \pm 13$  seconds) comparable to wild-type ( $P=0.52$ ). The result shows that *aex-3* reporter construct on wild-type worms had a significant effect due to an increase in defecation cycle and decrease in the brood size, whereas in the control experiment, there was no effect of mCherry wild-type worm.

## **Section 3.8 The action of Black Widow Spider Venom**

### **Section 3.8.1 Partial purification of toxins from combined latrotoxins**

Black widow spider venom (combined latrotoxins) was supplied as a lyophilised extract from venom sac of *Latrodectus mactans tredecimguttatus*. Since the crude venom contains a variety of low molecular weight components in addition to the high molecular weight latrotoxins, it is necessary to separate these components in order to be able to specifically test for the action of the high molecular weight latrotoxins. Combined latrotoxins proteins were purified by size-exclusion chromatography, and protein concentration was determined using Bradford assay according to the methods described in section 2.9.1 and 2.9.2 respectively. Venom proteins eluted in 0.5ml fraction were run on a gel using denaturing LDS-PAGE. All the fractions from between 15-34 showed absorbance at 280nm (indicating protein), while fractions 23-27 contained proteins of 110-130kDa characteristic of the latrotoxins, and fractions 28-29 contained lower molecular weight proteins. It has been previously demonstrated that proteins of  $\sim 110$ kDa are toxic upon micro-injection into *C.elegans* [86], [45]. These data show successful size fractionation of combined latrotoxins extracts, and fractions that contain specific venom protein greater than 110kDa were pooled for micro-injection.

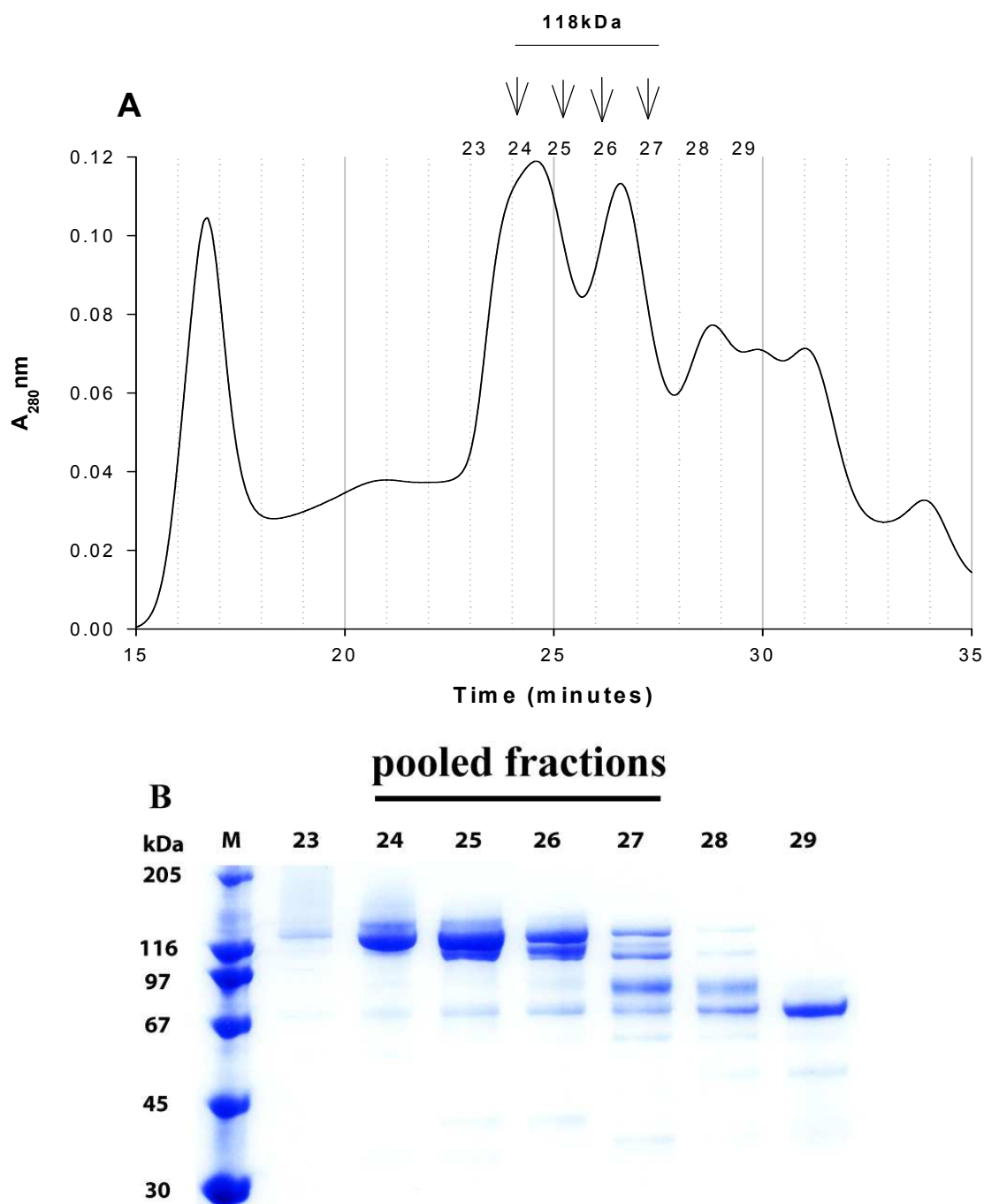

**Figure 3.15 Purification of combined latrotoxins protein.** **A** Size-exclusion chromatography of combined latrotoxins. 5mg of lyophilised Black Widow Spider Venom was dissolved in 20mM Tris at pH 8.0, 150mM NaCl, and loaded onto the Sephacryl S-200 column at 0.5ml/min. The absorbance at 280nm ( $A_{280nm}$ ) of the fraction eluate is represented by thick black line. Fractions (0.5ml) were collected ( corresponding to time 23-29) as shown on top of the graph. The position of pooled peak fractions of the same molecular weights for micro-injection is indicated by the black line (24-27; 118kDa). **B** shows denaturing LDS-PAGE of latrotoxin fractions. Fractions from size-exclusion chromatography (A) were collected for protein analysis. Eluted fractions were separated by running at 180V on 10% Bis-Tris gel for the visualisation of protein and stained using Coomassie Blue. The sizes of eluted proteins (time 23-29) are identified along side molecular weight marker (M) as shown above and the pooled fractions ( time 24-27) for micro-injection is underlined as thick lines.



### Section 3.8.2 Effect of combined latrotoxins on *C.elegans*

It is essential to determine whether the *C.elegans* lat-1 is required for mediating the toxicity of combined latrotoxins, prior to further investigation of the role of lat-1 gene in the mechanism of action of combined latrotoxins. RNAi knockdown of the lat-1 gene in wild-type worms showed resistance to combined latrotoxins (BWSV) [86], but these experiments are not definitive, since RNAi merely leads to knockdown, and RNAi is frequently tissue specific in *C. elegans* mCherry[101] [102]. Hence, it was desirable to study a genetic null (ok1465) allele of the lat-1 gene, to determine if lat-1 is required for the toxic effects of combined latrotoxins. However, it is important to compare the effect of combined latrotoxins on *C.elegans* lat-1(ok1465) worms and wild-type worms, with appropriate controls. Therefore, dose-effect curve of combined latrotoxins was carried out on lat-1(ok1465) worms, wild-type worms, and lat-1(ok1465) worms carrying various transgenes.

#### Section 3.8.2.1 Effect of combined latrotoxins on wild-type worms and lat-1(ok1465) worms

It is important to determine the dose-response relationship for combined latrotoxins on wild-type worms or lat-1(ok1465) worms to characterise its toxicity. Therefore, each concentration of combined latrotoxins was injected into 20 individual worms to study the effect of combined latrotoxins. The pooled size-exclusion chromatography column fractions of combined latrotoxins protein were at a concentration of 400 µg/ml, and these were diluted in 10-fold increments prior to injection. The injected worms were incubated at 20°C after recovery in M9 buffer and scored for the effect of combined latrotoxins after 3hrs. Dead worms were characterised by rod-like shape, slow movement of the body until death, and failure to respond to worm pick.

Wild-type worms were sensitive to combined latrotoxins with an LD<sub>50</sub> concentration of ~4 ng/ml, whereas lat-1(ok1465) worms were refractory to combined latrotoxins with 0% lethality at 400 µg/ml ( Figure 3.16). As the concentration of combined latrotoxins decreased from 400 µg/

ml to 40 fg/ml, the lethality in wild-type worms decreased gradually from 100% to 0%, showing a shallow dose-response. The results provide strong evidence that the *lat-1* gene was responsible for the toxicity of combined latrotoxins that killed wild-type worms, since the deletion in the *lat-1* gene was correlated with resistance to combined latrotoxins.

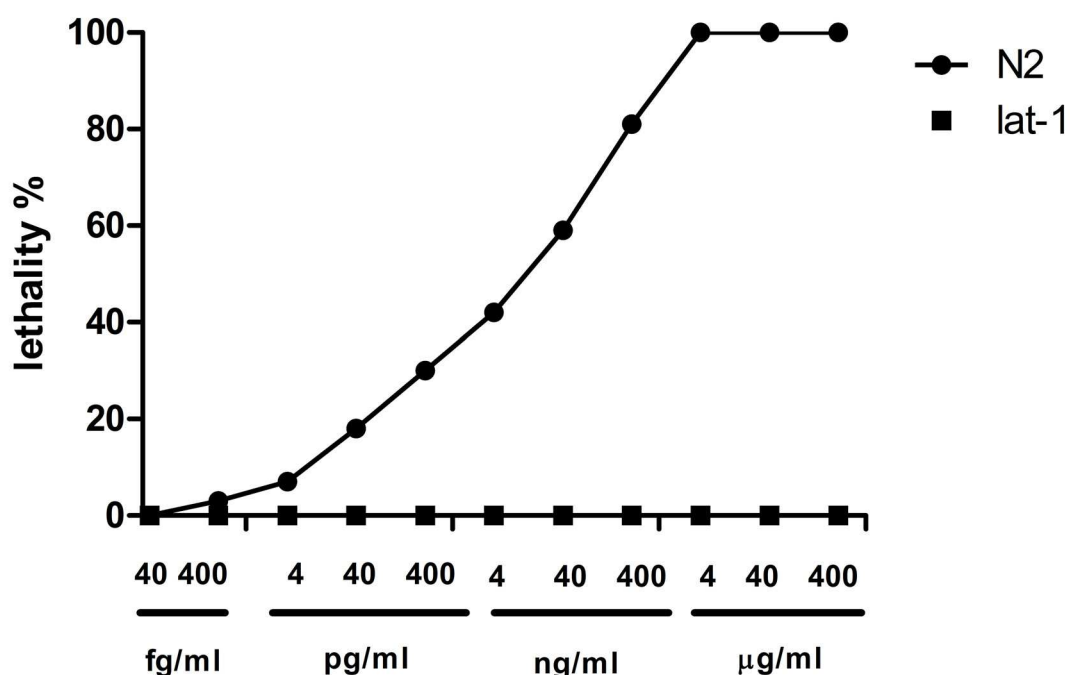

**Figure 3.16** A dose curve effect of combined latrotoxins on wild-type and *lat-1* worms. 20 wild-type or *lat-1(ok1465)* worms for each point were injected with combined latrotoxins in 10-fold serial dilution starting from concentration of 400 µg/ml. After injection, worms were recovered in M9 buffer before incubation at 20°C for 3hrs and thereafter scored for the effect of combined latrotoxins (section 2.7.3). Percentage of lethality (%) were plotted against dose concentration 400 µg/ml - 40 fg/ml. A dose-response curve (black circle) was obtained from the toxicity of combined latrotoxins that killed wild-type worms with LD<sub>50</sub> concentration of ~4 ng/ml. The *lat-1(ok1465)* worms was resistant to combined latrotoxins without dose-response curve (black box)

### Section 3.8.2.2 The *lat-1* gene confers sensitivity to combined latrotoxins in *lat-1(ok1465)* worms

The *lat-1(ok1465)* worms contain a deletion in the *lat-1* gene, but will additionally contain mutations in other genes, even after 6 outcrosses against N2. In order to investigate the hypothesis

that the deletion in the *lat-1* gene is responsible for resistance against combined latrotoxins, various constructs containing the *lat-1* gene were introduced into *lat-1(ok1465)* worms, and dose-response curves constructed with the resulting worms. B0457 cosmid contains the full sequence of the *lat-1* gene and rescued lethality and defecation defects in the *lat-1(ok1465)* worms.

Wild-type worms and B0457 transgenic worms were sensitive to combined latrotoxins and showed 100% lethality at the highest concentration dose of injection of 400  $\mu\text{g/ml}$ , whereas *lat-1(ok1465)* worms were less sensitive to combined latrotoxins with 5% lethality at 400  $\mu\text{g/ml}$  (Figure 3.17). The  $\text{LD}_{50}$  concentration of  $\sim 4$   $\text{ng/ml}$  was obtained from dose-response curve for the toxicity of combined latrotoxins that killed B0457 transgenic worms and wild-type worms. The results showed that the B0457 cosmid conferred susceptibility to the toxicity of combined latrotoxins to *lat-1(ok1465)* worms.

The B0457 cosmid contains multiple genes in addition to *lat-1*, and so does not definitively prove that *lat-1* confers sensitivity to combined latrotoxins. Additionally, the full-length *lat-1* would presumably result in the generation of the normal three transcripts of *lat-1* (i.e. a, b and c). Hence to definitively test the hypothesis that *lat-1a* can confer sensitivity to combined latrotoxins, *lat-1(ok1465)* worms transgenic for the *lat-1a* cDNA were tested for sensitivity to combined latrotoxins. Transgenic worms or wild-type worms that were injected at the highest dose concentration of 400  $\mu\text{g/ml}$  showed 100% lethality of sensitivity with  $\text{LD}_{50}$  concentration of  $\sim 4$   $\text{ng/ml}$ , whereas *lat-1(ok1465)* worms injected at 400  $\mu\text{g/ml}$  showed 5% lethality of sensitivity, as shown in Figure 3.17.

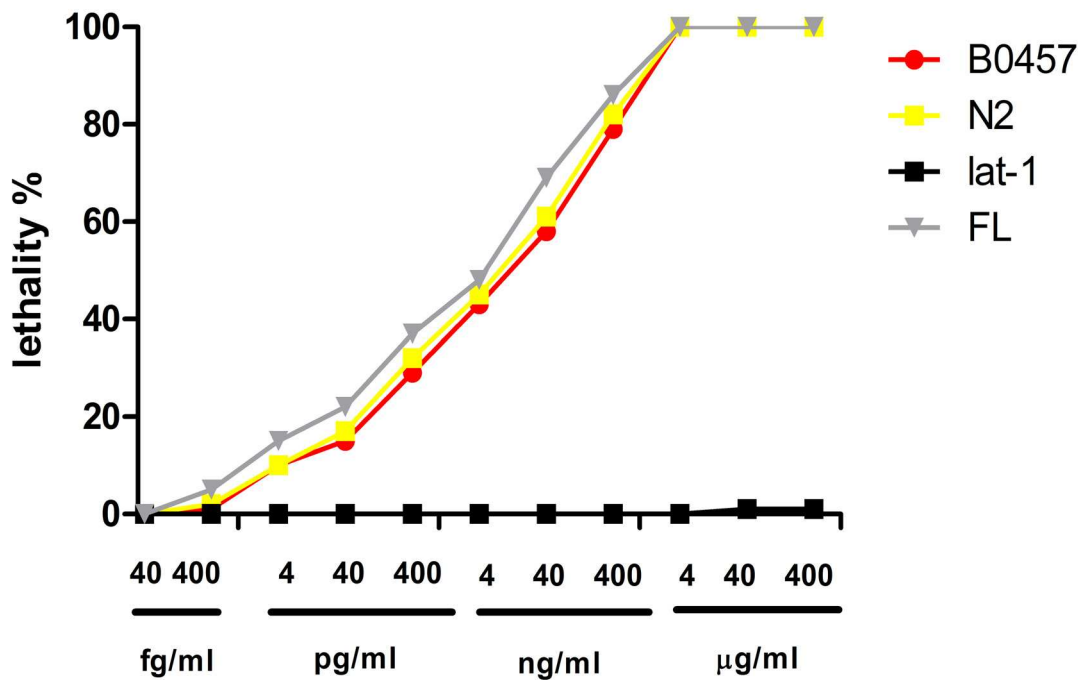

**Figure 3.17** A dose curve-effect of combined latrotoxins on full-length lat-1a or B0457 cosmid worms. 20 worms were injected with combined latrotoxins per point for each genotype at each dose as described in section 2.7.3. Percentage of lethality (%) were plotted against dose concentration 400 µg/ml-40 fg/ml. A dose curve-effect was obtained from wild-type worms (yellow) and lat-1(ok1465) worms that were transgenic for full-length lat-1a cDNA (gray) or B0457cosmid (red) with LD<sub>50</sub> concentration of ~4 ng/ml, and with lat-1(ok1465) worms (black).

The results showed that lat-1a cDNA transgenic worms and wild-type worms were sensitive to combined latrotoxins, whereas lat-1(ok1465) worm were resistant to combined latrotoxins. Thus, full-length lat-1a was responsible for the sensitivity to toxicity of combined latrotoxins that killed transgenic worms, and this proves that the absence of lat-1 gene in lat (ok1465) worm leads to resistance to combined latrotoxins.

### Section 3.8.2.3 Defining regions of lat-1a required for combined latrotoxins toxicity

Given that the lat-1a gene confers sensitivity to combined latrotoxins on lat-1(ok1465) worms, it is possible to determine the regions of lat-1 that are required for this functionality by undertaking a systematic mutagenesis of the lat-1 gene. A series of C- and N- terminal deletions were

constructed, and used to create transgenic lat-1(ok1465) worms; the resulting worms were then tested for sensitivity to combined latrotoxins.

#### **Section 3.8.2.3.1 C-terminal deletions of lat-1a**

Two different types of transgenic animals were obtained from micro-injection of C-terminal lat-1a deletion constructs into lat-1(ok1465) worms. The 4xCys construct fully rescued lat-1(ok1465) worms, and the TM7 construct partially rescued lat-1(ok1465) worms. Therefore, it was important to find out the effect of combined latrotoxins to elucidate the roles of functional regions of the lat-1a C-terminus in respect of their abilities to mediate the toxicity of combined latrotoxins. The wild-type worms or lat-1(ok1465) worms carrying 4xCys construct were sensitive to the combined latrotoxins and showed 100% lethality at the highest concentration dose injection of 400 µg/ml with an LD<sub>50</sub> concentration of ~40 ng/ml, while the TM7 transgenic worms only showed 50% lethality to combined latrotoxins at the highest concentration of 400 µg/ml. The lat-1(ok1465) worms injected with combined latrotoxins at 400 µg/ml showed 0% lethality. Truncation of the C-terminus of lat-1a to the area of four cysteine domain yielded worms that had a sensitivity to the toxicity of combined latrotoxins that was close to wild-type, showing that the region of the C-terminus after the 4xCys domain is not required for signalling in combined latrotoxins toxicity. However, when the C-terminus was deleted back to the seven transmembrane domain of lat-1a, the resulting worms were ~10<sup>4</sup>-fold less sensitive to combined latrotoxins than the corresponding 4xCys worms. Therefore, C-terminal sequence of lat-1 after the TM7 domain is required for the action of lat-1 mediated combined latrotoxins toxicity, and the transmembrane domain itself is not sufficient to mediate the toxicity of combined latrotoxins in *C. elegans*.

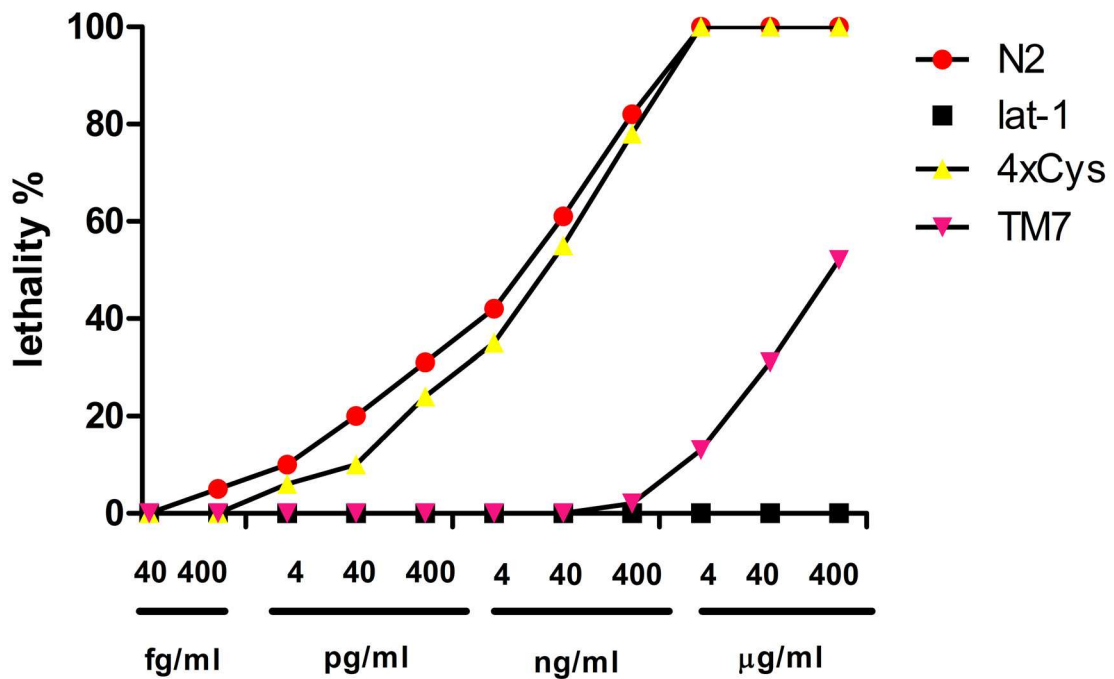
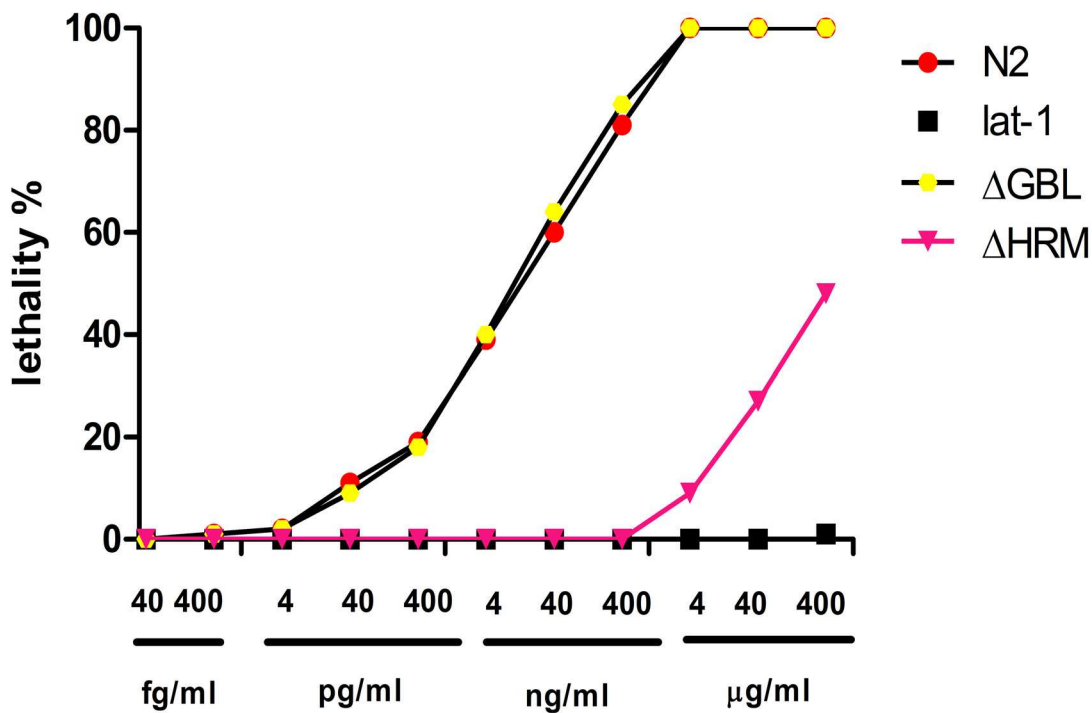

**Figure 3.18 Dose-response of combined latrotoxins on C-terminally-truncated lat-1a worms.** 20 worms were injected with combined latrotoxins per point for each genotype as described in section 2.7.3. The graph shows the plot of percentage of lethality (%) against dose concentration 400  $\mu\text{g/ml}$ -40  $\text{fg/ml}$ . A dose-curve effect was obtained from wild-type worms (red) and lat-1(ok1465) worms (black) that were transgenic for area of four cysteine domain [4xCys] (yellow) with  $\text{LD}_{50}$  concentration of  $\sim 4$   $\text{ng/ml}$ . The lat-1 (ok1465) worms that were transgenic for seven transmembrane domain [TM7](magenta) showed 50% lethality at the highest concentration, 400  $\mu\text{g/ml}$ , while lat-1(ok1465) worms (black) were refractory to toxin treatment.

### Section 3.8.2.3.2 N-terminal deletions of lat-1a

Two plasmids containing N-terminal deletions of lat-1,  $\Delta\text{GBL}$  and  $\Delta\text{HRM}$ , partially rescued lat-1(ok1465) worms. It is important to find out the roles of these two regions within lat-1a cDNA with respect to the toxicity of combined latrotoxins. Transgenic worms carrying  $\Delta\text{GBL}$  and wild-type worms were sensitive to combined latrotoxins and showed an  $\text{LD}_{50}$  concentration of  $\sim 4$   $\text{ng/ml}$ , while lat-1(ok1465) worms that were transgenic for  $\Delta\text{HRM}$  showed  $\sim 50\%$  lethality at 400  $\mu\text{g/ml}$ . lat-1(ok1465) worms were resistant to combined latrotoxins with 0% lethality at 400  $\mu\text{g/ml}$ . Hence, deletion of the galactose-binding lectin domain had little effect on sensitivity

to the toxicity of combined latrotoxins, since the  $\Delta$ GBL transgenic worms had equal sensitivity to wild-type, while deletion of the hormone receptor motif domain of lat-1a reduced sensitivity to the toxicity of combined latrotoxins by  $\sim 10^5$ -fold, compared to  $\Delta$ GBL worms.

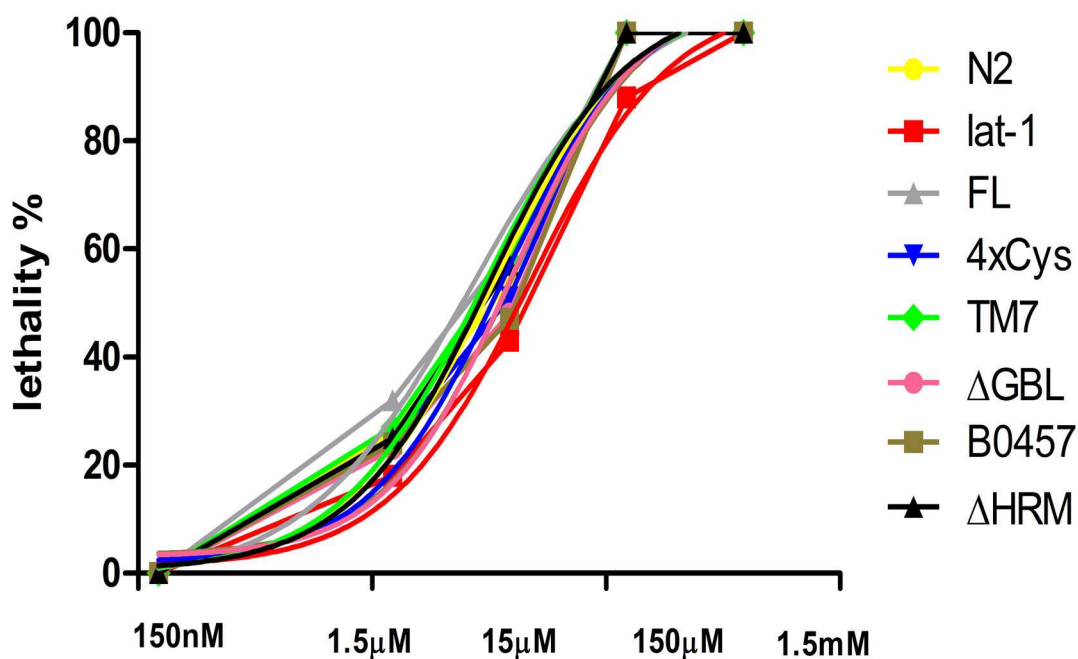

**Figure 3.19 Dose-response of combined latrotoxins on N-terminally truncated lat-1a worms.** 20 worms were injected with combined latrotoxins per point for each genotype as described in section 2.7.3. The graph shows the plot of percentage of lethality (%) against dose concentration 400  $\mu$ g/ml-40 fg/ml. A dose-curve effect was obtained from wild-type worm (red) and lat-1(ok1465) worms that were transgenic for galactose-binding lectin domain deletion [ $\Delta$ GBL](yellow) with  $LD_{50}$  concentration of  $\sim 4$  ng/ml. The lat-1(ok1465) worms that were transgenic for hormone receptor motif domain deletion [ $\Delta$ HRM](mangeta) showed 50% lethality at the highest dose, 400  $\mu$ g/ml, while lat-1(ok1465) worms (black) were insensitive to toxin.

### Section 3.8.3 Dose-effect curve of potassium cyanide (KCN) on transgenic worms, lat-1(ok1465) worms and wild-type worms

It is possible that the differential toxicity of combined latrotoxins in the various transgenic worms could be due to the lat-1 constructs conferring a non-specific susceptibility to toxicity. In order to show that the results seen are specific to combined latrotoxins, it was important to test the effect of toxic compound with a distinct mode of action, and potassium cyanide (KCN)

was used to obtain a dose-effect curve. To study the effect of KCN, 20 transgenic animals including the wild-type and *lat-1(ok1465)* worms were injected in 10-fold serial dilution from start concentration of 1.5 mM of KCN. The injected worms were recovered in M9 buffer before incubation at 20°C for 3hrs and scored for the effect of KCN. All the worms from each genotype were sensitive to KCN and showed 100% lethality at the highest concentration, with LD<sub>50</sub> concentration of ~15 μM.



**Figure 3.20** A dose curve-effect of KCN on *C.elegans*. 20 worms were injected with KCN per point for each genotype as described in section 2.7.3. The graph shows the plot of lethality (%) against dose concentration 1.5 mM-150 nM. A dose-curve effect was obtained from all the injected worms of each genotype; Wild-type [N2] (yellow), *lat-1(ok1465)* worms[*lat-1*] (red), *lat-1(ok1465)* worms transgenic for full-length *lat-1a* cDNA[FL] (gray), area of four cysteine domain[4xCys](blue), seven transmembrane domain[TM7](green), galactose-binding lectin domain deletion[ΔGBL](magenta), hormone receptor motif domain deletion [ΔHRM](black) or B0457 cosmid [B0457] (brown) with LD<sub>50</sub> concentration of ~15 μM.

The result showed that KCN killed all the injected worms with an LD<sub>50</sub> concentration of ~15 μM. These data exclude the possibility of non-specificity of combined latrotoxins toxicity to



transgenic animals, wild-type or lat-1(ok1465) worms. Therefore, the sensitivity or resistance of combined latrotoxins was due to the presence or absence of lat-1 gene respectively.

## Chapter 4 Discussion

### Section 4.1 Optimisation of transgenesis

Micro-injection was optimised for transgenesis of *C.elegans* to overcome the initial failure to obtain transgenic worms. One difficulty, ensuring accurate injection, was overcome by injecting rhodamine into the gonad of *C.elegans* as described in section 3.1.1. This experiment proved to be successful after targeting the gonad of *C.elegans* as reflected by the restriction of the red-fluorescence of rhodamine to the gonad. The installation of air-conditioning in the micro-injection room gave temperature control and contributed to the survival of injected worms that yielded transgenesis. While it is not possible to definitively identify temperature as the key determinant for successful transgenesis from this anecdote, it is suggestive that temperature control is essential for successful transgenesis; this is consistent with previous work, that shows *pgl-1* mutants show meiotic failure at higher temperatures [103].

DNA concentration was optimised for transformation of *C.elegans* to obtain stable lines. Two different selectable markers (pRF4:roller phenotype and pAA413:body-wall muscle expression of the Cerulean GFP) were used to obtain various stable lines with different concentrations as described in 3.1.2. The highest concentration of individual selectable marker yielded stable line, and the lowest concentration yielded no stable line. The result showed that it was possible to obtain stable line at the optimum DNA concentration of  $>50 \mu\text{g/ml}$  for either pRF4 or pAA413. These data are similar to findings reported for micro-injection of DNA into the distal arm of gonad [92], [91]. The number of stable lines obtained is dependent on the DNA concentrations used for injection, and this report is consistent with Mello et al (1991). Therefore, DNA concentration is a key variable for successful transgenesis in *C.elegans*.

### Section 4.2 The phenotype of *lat-1* allele

The deletion of *lat-1* gene in *ok1465* allele by mutagenesis as described in section 3.2.1 was

characterised and studied for offspring lethality after outcrossing against wild-type worms six times. The *lat-1* (*ok1465*) worm was under-represented and this is unlikely to be due to an unrelated mutation present in the *ok1465* allele. The under-representation of adult *lat-1* homozygous worms was shown to be due to death during embryogenesis or larval stages. Investigation of *lat-1* allele showed that 95-98% of its offspring die during developmental stages with only ~2-5 adult offspring from about 200 embryos per animal. The rate of lethality in homozygous *lat-1* worms is similar (~95-98%) in offspring derived from either homozygous or heterozygous *lat-1* parents; therefore the lethality is unlikely to be due to a maternal effect gene. Observed embryonic lethality occurs at the time of epithelial morphogenesis, which is late for typical maternal effect genes. Analysis of the *ok1465* allele showed developmental lethality in offspring after it had been outcrossed six times against wild-type animals. It is possible that the lethal phenotype manifest in *lat-1(ok1465)* worms is due to the deletion of *lat-1* gene or to a genetically linked mutation. However, it is important to understand why the offspring of *lat-1* animals die during embryonic or larval stage and determine the cause of the lethality. Therefore, it is essential to determine the role of the *lat-1* sequence in *lat-1* (*ok1465*) worms in order to gain insight into the understanding of the phenotype of *lat-1* worms.

### **Section 4.3 Expression of *lat-1* reporter gene**

It is important to know in which cells the endogenous *lat-1* gene is expressed in the wild-type worm as this will help to clarify the role of *lat-1* gene. Therefore, a transcriptional fusion of *lat-1* gene under the control of the *lat-1* promoter fused to *lacZ* reporter gene ( $\beta$ -galactosidase nuclear localisation signal) or *gfp* reporter gene (green fluorescent protein) was examined: both of the *gfp* or *lacZ* reporters allow microscopic visualization in *C.elegans*, allowing characterisation for the expression of the gene of interest [97] [104]. The idea of using different reporter genes was to find out if the same promoter driving two different reporter genes e.g *gfp* or *lacZ* would produce similar expression patterns for the study of *lat-1* promoter, and thereby provide a more

robust characterisation of the level and cell-specificity of *lat-1* gene expression. Analysis of embryos with the *lat-1::gfp* reporter fusion showed that GFP was expressed in hypodermal cells during dorsal intercalation (Figure 3.6C) and continued in 2-3-fold stage embryonic development as described in section 3.3.2. This expression pattern of *lat-1* gene promoter in the gut cells of 3-fold stage of the *gfp* reporter fusion is similar to the gut expression of 3-fold stage of *lacZ* fusion either for ~1.5kb or ~3kb of *lat-1* gene promoter, but technical difficulties precluded analysis of the *lacZ* fusions in earlier embryos. The expression of *lat-1* gene promoter detected in the gut cells and two tail neurons of larval or adult stage for ~1.5kb, *lacZ* transgenic worm is similar to that of ~3kb, *lacZ* transgenic worm. The same expression pattern (gut cells, two tail neurons) is found in larval or adult stages of ~1.5kb, *gfp* transgenic worm as described in section 3.3.2.

The expression pattern of *gfp* or *lacZ* reporter genes was detected in the same cells of all stages of transgenic worms obtained. The fact that two different lengths of *lat-1* promoter (the ~3 and ~1.5 kb fragments), and different reporter genes, in multiple independent transgenic worms, show similar and consistent expression patterns is a strong indication that these findings are robust and indicate the expression pattern of the endogenous *lat-1* gene. The high expression of these reporter genes in embryonic stages of the worm is also consistent with real-time PCR analysis of *lat-1* transcripts (Susann Lehmann, unpublished data) showing higher expression of *lat-1* in embryonic stages. This finding is consistent with data that showed *lacZ/gfp* reporter gene expression was detected in the same cells [105] [106] [107] [108].

#### **Section 4.3.1 Expression of *lat-1* gene and physiological relevance**

The expression of the *lat-1* reporter gene in hypodermal cells during epidermal enclosure is consistent with a role for *lat-1* in the embryonic arrest seen in the *lat-1(ok1465)* worm during epidermal morphogenesis, suggesting that the *lat-1* gene is important in embryonic development.

Additionally, both marker genes driven by the *lat-1* promoter were expressed in the embryonic and larval gut, and this is the site where the gut fails to attach to the pharynx in larval arrest of some *lat-1(ok1465)* larvae (Figure 3.3A). The concordance between site of expression and the site of the phenotype in *lat-1(ok1465)* worms is further evidence that the *lat-1* gene causes the phenotype. This result is similar to the finding that showed *cpl-1* gene is important for the development of embryos in mutant worms with embryonic lethality, and also consistent with the expression of *cpl-1* gene using *lacZ* or *gfp* transcriptional fusion that produced gut cell expression during embryogenesis [106].

Expression of *lat-1* gene in the gut of wild-type worm in larval stages and in adult can be correlated with the extended defecation cycle phenotype seen in *lat-1(ok1465)* worm. It is possible that *lat-1* gene is important for development of gut in the larval stages of *lat-1(ok1465)* worms as the *lat-1* gene is expressed in L1 stage of wild-type worm, and is responsible for the rescue of defecation cycle extension in *lat-1(ok1465)* animals. It is known that defecation cycle defects can be caused either by defects in the innervation of the defecation cycle machinery, or defects in the guts and excretory cells themselves [66] [109] [98]. Thus the fact *lat-1* promoter is capable of driving *lacZ* or *gfp* reporter fusion for gut cell expression, together with the fact that the *lat-1a* cDNA rescues the defecation cycle defect in *lat-1(ok1465)* worms, make a compelling case that it is gut expression of *lat-1* which is affecting the defecation cycle.

The ability of *lat-1* gene to express in the intestinal cell of *C.elegans* suggests that the gut could be the site of action for the toxicity of combined latrotoxins (BWSV) that killed *C.elegans*, suggesting a distinct site for the activity of toxins. The expression of *lat-1* in identified tail neurons that are known to serve as interneurons that regulates forwards and backwards locomotions, is unlikely to account for the toxicity of combined latrotoxins in *C.elegans*; these neurons are not necessary for development or survival of *C. elegans*. The highly restricted expression of *lat-1*

in the *C.elegans* nervous system is in marked contrast to the restricted expression of mammalian latrophilin-1 in the rat nervous system [110]. By contrast, mammalian latrophilins 2 and 3 show widespread expression outside the nervous system [15], and these are therefore more likely to be playing an analogous role to lat-1 in the worm.

### **Section 4.3.2 Characterisation of rescue of lat-1 (ok1465) worm phenotype**

The initial study of lat-1 (ok1465) worm showed that lat-1 animal has ~95% offspring lethality and outcrossing of lat-1 worm against N2 worm six times did not rescue the lethality. Micro-injection of B0457 cosmid that contains the full-sequence of lat-1 gene rescued the lethality of lat-1(ok1465) worms, indicative of the importance of the lat-1 gene on the B0457 cosmid. Further analysis of the transgenic worms showed that all of these rescues were full rescues; the defecation defect or developmental arrest phenotype was rescued to the point where animals that contained a copy of the rescuing cosmid were able to grow to adulthood and produce progeny, and also showed defecation cycle close to wild-type worm. The lat-1a transcript of lat-1 gene was tested to support the prove that the presence of lat-1 gene was responsible for the rescue of lethality of lat-1(ok1465) worms, as this experiment is required to exclude the possibility that other genes on the B0457 cosmid could ameliorate the phenotype of lat-1(ok1465) worms. The data showed that full-length lat-1a fusion rescued the developmental lethality of lat-1(ok1465) worm as described in section 3.5.1. It has been reported that cosmid containing full sequence of dpy 20 gene rescued mutant phenoptype of animal homozygous for dpy 20 allele back to wild-type worm [111]; this type of analysis provides compelling evidence of the importance of the lat-1 gene in the rescue of lat-1(ok1465) worms.

In passing, this experiment additionally confirms that the ~1.5kb promoter of lat-1 is driving the expression of the lat-1 cDNA at appropriate time to complement the lethality in lat-1(ok1465) worms, arguing that this promoter drives physiologically relevant expression. Further, the lat-

1a cDNA must be physiologically functional, since it complements the lat-1(ok1465) allele. There is no obvious consequence of losing the lat-1b transcript, since the lat-1a transgenic animals are not different from wild-type animals; it is therefore not clear if any distinct physiological role is served by the lat-1a and lat-1b transcripts.

The finding that latrophilin, a GPCR, plays an important role in development, is not unprecedented. The GPCRs signal principally through a pathway involving G-proteins [112], and G-proteins are known to play an essential role in development [113] [114]. For example, they are known to regulate cardiogenesis in the mouse [115] and play an important role in the orientation of cell division during embryonic development of *C.elegans* [116]. GPCRs are frequently targeted during drug development [117], but the class B (secretin) family of GPCRs are less well understood or characterised in their physiological roles. One class B GPCR plays an essential role for physiological functions to target drugs for various diseases [118]. As a member of class B/secretin subfamily of GPCRs, lat-1 gene has a critical role in development and the defecation cycle in the worm, and so this system offers the ability to investigate the role of the class B GPCRs in developmental processes.

These results show that transgenic expression of lat-1a rescues the lat-1(ok1465) worms, and provides compelling evidence that the lat-1 defect is responsible for the phenotype seen in lat-1(ok1465) worms. This work therefore corroborates the bioinformatic analysis of the function of this gene, and suggests that the ok1465 allele yields non-functional variants of lat-1.

## **Section 4.4 The role of lat-1 gene in *C.elegans***

### **Section 4.4.1 Importance of lat-1a C-terminus**

The role of lat-1a C-terminus is investigated to understand the importance of this region with respect to the rescue lat-1(ok1465) worm. Three various truncations of lat-1a C-terminus; 4xCys, TM7, TM1 were investigated to determine whether a truncated lat-1a protein rescued

the developmental lethality of lat-1(ok1465) worm. The 4xCys rescued lat-1 animals, TM7 partially rescued lat-1 animals, while TM1 failed to rescue lat-1 animals as described in section 3.5.2. Interestingly, the rescue of developmental lethality in 4xCys worm is similar to that of full-length lat-1a worm, indicating that the sequence after the 4xCys domain is not required for phenotypic rescue. However, the failure of the TM1 construct to rescue lat-1(ok1465) worm indicates that the TM7 domain of lat-1a is important for intracellular signalling.

All GPCRs contain a TM7 domain that plays an important role in intracellular signalling [9]. This finding has demonstrated the importance of the TM7 domains in the rescue of lat-1(ok1465) worms as deletion of C-terminus lat-1a to transmembrane one showed no functionality, suggesting that intracellular signalling is important. It has been shown that an analogous TM1 deletion mutant of rat latrophilin (deletion of six of seven transmembrane domains; TM7) binds to  $\alpha$ -latrotoxin, that the extracellular domain binds to this ligand, and thus suggesting that the failure of the *C. elegans* TM1 construct to rescue lat-1 worms should be viewed as a failure not of ligand-binding, but of signal transmission into the cell. Moreover, the rat latrophilin TM1 mutant had a reduced ability to allow calcium entry elicited by binding of  $\alpha$ -latrotoxin, indicating its inability to activate G-protein for cell signalling [5], and consistent with the finding that shows the TM7 domain of lat-1a is required for the rescue of lat-1 (ok1465) worm. Taken together, TM7 domain of latrophilin is important for intracellular signalling in the endogenous function of this receptor.

#### **Section 4.4.2 Importance of lat-1a N-terminus**

The role of lat-1a N-terminus was investigated in the rescue of lat-1(ok1465) worms, since the mammalian latrophilin (a member of GPCRs) is known to bind ligand [7]. A series of lat-1a N-terminus deletion made include;  $\Delta$ GBL,  $\Delta$ HRM,  $\Delta$ N and they were tested for the ability to rescue the developmental lethality of lat-1(ok1465) worms. The  $\Delta$ GBL or  $\Delta$ HRM construct par-



tially rescued the developmental lethality of *lat-1(ok1465)* worms, and  $\Delta N$  construct failed to rescue the lethality of *lat-1(ok1465)* worms, indicating the importance of GBL or HRM for the rescue of *lat-1(ok1465)* worms.

It is interesting to find out that  $\Delta GBL$  or  $\Delta HRM$  construct rescued defecation defect in *lat-1(ok1465)* worms but failed to fully rescue *lat-1* worms; one possibility is that different ligands are required for rescue of the defecation cycle, and lethality, and this is reflected in the requirement for different domains of the N-terminus of *lat-1*. Thus, the presence of galactose-binding or hormone receptor motif domain is important for the rescue of developmental lethality, but not required for defecation defect in *lat-1(ok1465)* worms. However, another possibility is that the same ligand is involved in both phenotypes, but that there is a bias in measurement; specifically, that the worms which die during development would have a defect in defecation cycle, but that those worms which happen to survive during development do so by means of some compensating adjustment which also restores the defecation cycle. A recent finding is that the galactose-binding lectin like domain of mouse latrophilin-1(*lat-1*) is functional in a carbohydrate binding assay [119]. However, this functionality is not the key ligand-binding role of *lat-1*, since the galactose-binding lectin domain of *C.elegans lat-1a* has only a minor effect in rescuing *lat-1(ok1465)* worms. It may be that the GBL domain serves to anchor the *lat-1* protein so that ligand can more efficiently bind to the HRM domain.

The GBL and HRM domains are conserved in the N-terminus of latrophilin (also known as CIRL), which is known to bind to  $\alpha$ -latrotoxin [7], [120]. Deletion of residues from 467-538 in the N-terminus of rat latrophilin resulted in a failure to bind toxin, and this region (477-537) corresponds to the HRM domain; deletion of sequences N-terminal to 467 (*i.e.* the olfactomedin and galactose-binding lectin domains) did not affect the ability of constructs to bind to  $\alpha$ -latrotoxin [5]. The failure in function of the *C. elegans lat-1* after the deletion of analogous domains

of the protein suggests that the HRM domain of latrophilin is essential for rescue of worms because of its ability to bind to a ligand.

### **Section 4.5 TM1 acts as a dominant negative**

The failure of the TM1 truncation in the C-terminus of lat-1a or the  $\Delta$ N truncation in the N-terminus of lat-1a to yield stable lines when injected into lat-1(ok1465) worm suggests that these constructs may not only fail to confer complementation, but could additionally have a frank toxic effect. A hypothesis is that when the TM1 construct is introduced into wild-type worm, the TM1 receptor will decoy ligand from binding to the endogenous receptor, hence resulting in lack of intracellular signalling. This hypothesis suggests the TM1 construct will be a dominant negative in wild-type worms by preventing intracellular signalling, as shown in Figure 4.1A. An essential control is to test whether ectopic expression of the lat-1a cDNA is per se capable of causing adverse effects; however, according to the hypothesis, when full-length lat-1a interacts with ligand, it presumably causes intracellular signalling through G-protein pathway (Figure 4.1B).

To test the hypothesis, the injection of TM1,  $\Delta$ N, full-length lat-1a or mCherry construct into wild-type worms was carried out. N2 worms transgenic for the TM1 construct showed a significant reduction (~50%) in the number of the embryo that reached adulthood, characterised by embryonic arrest or larval death, and an increased defecation cycle; these are the characteristic features of the lat-1(ok1465) allele. The effect of TM1 can not be a non-specific toxicity arising from overexpression of lat-1a or a defective lat-1a, because the full-length lat-1a construct had no adverse effect. Also, it can not be a non-specific consequence of a non-functional lat-1a, as  $\Delta$ N truncation of lat-1a did not have any adverse effect either. Therefore, the TM1 construct acts

as a dominant negative in wild-type worms to phenocopy the *lat-1* null.

**A** TM1 *lat-1a*

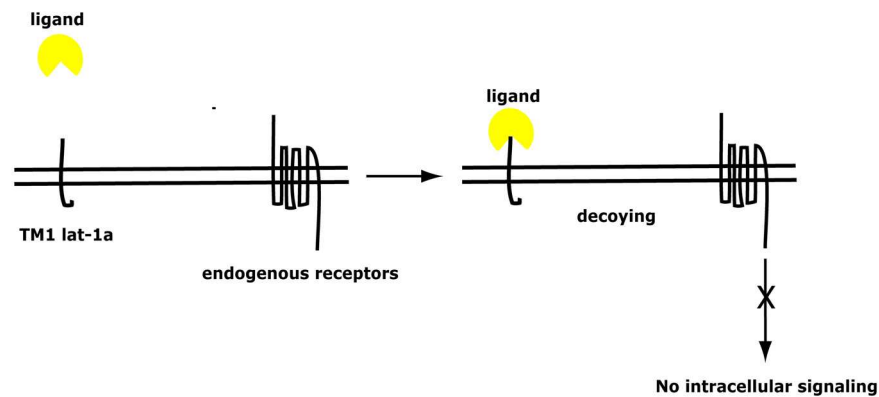

**B** Full-length *lat-1a*

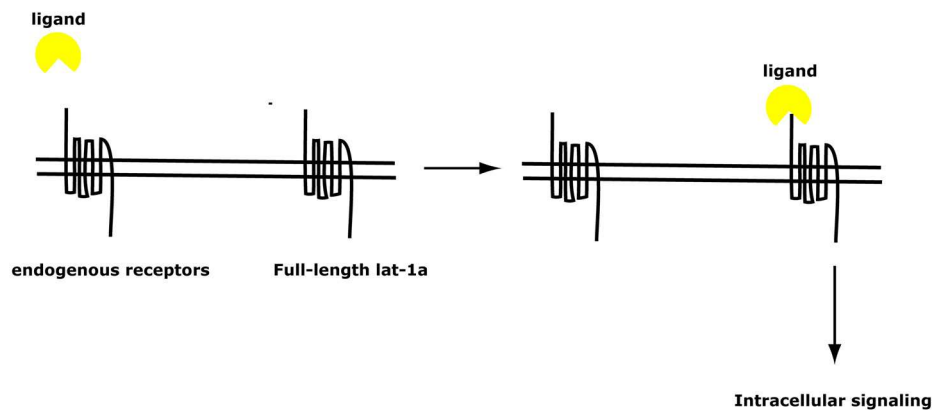

**Figure 4.1** TM1 decoying pathway. **A** shows TM1 interaction with ligand and decoying of ligand from endogenous receptors which results in a lack of intracellular signalling. **B** shows full-length *lat-1a* interaction with ligand, and binding of ligand to receptor results in intracellular signalling.

## Section 4.6 *aex-3* promoter for tissue-specific expression of *lat-1a*

Latrophilin was originally isolated and expressed in mammalian brain, and previous findings have demonstrated that mammalian latrophilin-1 is highly expressed in nervous system [6] [110] [121]. Latrophilin-1, latrophilin-2, and latrophilin-3 are known to have different tissue distributions in mammals, and all three share homology with *C.elegans* *lat-1* [15] [87]. Latrophilin was expressed in the nervous system of *C.elegans* to determine if expression of the *C.elegans* *lat-1* in the nervous system can complement the lethality of the *ok1465* worm. Iwasaki and his group have shown that the *aex-3* promoter confers nerve-specific expression [100]. The

*aex-3* promoter was swapped with the *lat-1* promoter driving full-length *lat-1a* cDNA and micro-injection of *aex-3* construct into *lat-1(ok1465)* worms produced many transgenic embryos but failed to yield stable lines, showing that the *aex-3* promoter driving *lat-1a* cDNA could not rescue the lethality of *lat-1(ok1465)* worms. It can therefore be concluded that the *aex-3* promoter was not capable of driving *lat-1a* cDNA to rescue *lat-1* animals, and this suggests that expression of *lat-1* in the nervous system is not critical for the role of *lat-1* in *C.elegans*.

The *aex-3* construct was tested on wild-type worms as it could not rescue *lat-1(ok1465)* worms, therefore testing the hypothesis that nerve-specific expression of *lat-1a* might be toxic to wild-type worms. Micro-injection of *aex-3* construct or mCherry into wild-type worms produced many transgenic embryos that survived to adulthood. The *aex-3::lat-1a* worm and mCherry worm were further characterised and *aex-3::lat-1a* worm produced half of normal brood size of wild-type worm or mCherry worm, showing an adverse effect of the *aex-3* construct. Notably, embryos from *aex-3::lat-1a* worm survived to adulthood without showing developmental arrest, in contrast to *lat-1(ok1465)* worms, which show embryonic and larval lethality. Thus, the *aex-3::lat-1a* worm does not exhibit the same phenotype of *lat-1(ok1465)* worm, although there is a reduction in brood size. Study of the defecation cycle in *aex-3::lat-1a* worms showed that it was significantly increased when compared to wild-type worm or mCherry worm, and this was due to the effect of *aex-3* construct. The fact that *aex-3::lat-1a* worm did not show developmental lethality shows that this defect is not a phenocopy of the *lat-1* null defect, but that the *aex-3* promoter is driving inappropriate or tissue-specific expression that causes reduction of brood sizes in wild-type worms. The *aex-3::lat-1a* influenced the defecation cycle of wild-type worm; however it is known that *aex-3* is important for some aspect of *C.elegans* defecation cycle [65], and that the nerve cell expression of *aex-3* affects defecation cycle [100], [122]. Thus it is not surprising that a physiological function of *lat-1a* in cells that are known to control def-

ecation cycle, can lead to alterations in defecation cycle. However, the functions of the majority of adhesion GPCRs, including latrophilin-1, are yet to be fully understood with only a few that are expressed in tissue [123]. While the lat-1 gene promoter confers expression in tail neurons of wild-type *C.elegans* nervous system, tissue-specific expression of lat-1 gene under the control of *aex-3* promoter in *C.elegans* nervous system had adventitious toxicity in wild-type worms, and failed to rescue lat-1(ok1465) animals. It is difficult to sustain the notion that the expression of lat-1 in the nervous system is critical for the role of lat-1 in *C.elegans*.

### **Section 4.7 Mechanism of action of combined latrotoxins in *C.elegans***

One of the aims of this thesis is to understand the action of combined latrotoxins on latrophilin (lat-1) in *C.elegans*. The wild-type worm and lat-1(ok1465) worm were injected with combined latrotoxins to investigate the level of toxicity and thereby characterise the role of endogenous lat-1 receptor. Figure 3.17 showed a dose-curve response with LD<sub>50</sub> at 4 ng/ml for wild-type worm, indicating that endogenous lat-1 gene mediates the toxicity of combined latrotoxins. At 400 µg/ml (~10<sup>5</sup>-fold greater than LD<sub>50</sub> at 4 ng/ml), there was no effect of combined latrotoxins in lat-1(ok1465) worm with 0% lethality, suggesting that deletion of lat-1 gene conferred the resistance. Although, lat-1(ok1465) worm has a deletion of the lat-1 gene which conferred resistance to combined latrotoxins, the presence of other receptors such as neurexin and phosphatase-sigma in lat-1 (ok1465) worms did not mediate any toxicity from combined latrotoxins. Therefore, lat-1 gene is solely responsible for the toxicity of combined latrotoxins.

#### **Section 4.7.1 Combined latrotoxins are sensitive to lat-1 gene in lat-1(ok1465) worm**

It is important to investigate the hypothesis that absence of lat-1 gene is responsible for the toxicity of combined latrotoxins, thus lat-1 worms carrying various constructs containing lat-1 gene were injected with combined latrotoxins to obtain dose-curve response. Combined latrotoxins killed B0457 worm and full-length lat-1a worm with an LD<sub>50</sub> of 4 ng/ml, which is con-

sistent with the concentration ( $LD_{50}$  4 ng/ml) that killed wild-type worm (Figure 3.16, 3.17, 4.2A), indicating the importance of lat-1 gene in the toxicity of combined latrotoxins. These data are consistent with the finding that the lat-1 gene is important for the rescue of lat-1(ok1465) worms (Figure 4.2A). The sensitivity of B0457 worm to combined latrotoxins reflects the presence and ability of lat-1 gene on B0457 cosmid to mediate the toxicity of combined latrotoxins. The mediation of toxicity by full-length lat-1a ablates the possibility that presence of other genes on B0457 cosmid that could mediate the toxicity of combined latrotoxins. It can therefore be concluded the presence of lat-1 gene on B0457 cosmid was responsible for the toxicity of combined latrotoxins that killed B0457 worms. These data have shown that lat-1 gene is important for the rescue of lat-1(ok1465) worm, and that lat-1 gene was responsible for the toxicity of combined latrotoxins. One possible way to explain this mechanism of action of combined latrotoxins that killed wild-type worm, B0457 worm and full-length lat-1a worm is that presence of endogenous or exogenous lat-1 receptor mediates the toxicity of combined latrotoxins presumably through a G-protein pathway [124], [125].

Moreover, it is likely that the mechanism of action for the toxicity of combined latrotoxins in *C. elegans* is similar to the activation of  $\alpha$ -latrotoxin by mammalian latrophilin that suggests the mechanism of intracellular signalling through G-protein [126]. The mechanism of action of combined latrotoxins can be corroborated by investigating various regions of full-length lat-1a in the context of intracellular signalling in order to strengthen the hypothesis.

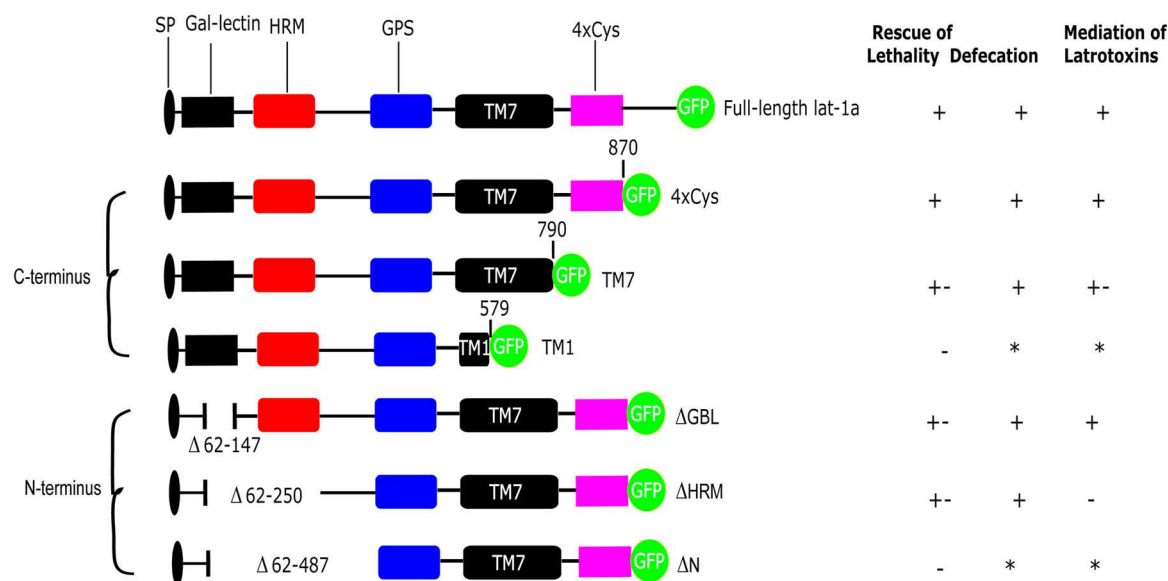
A *C.elegans* lat-1

## B Rat latrophilin

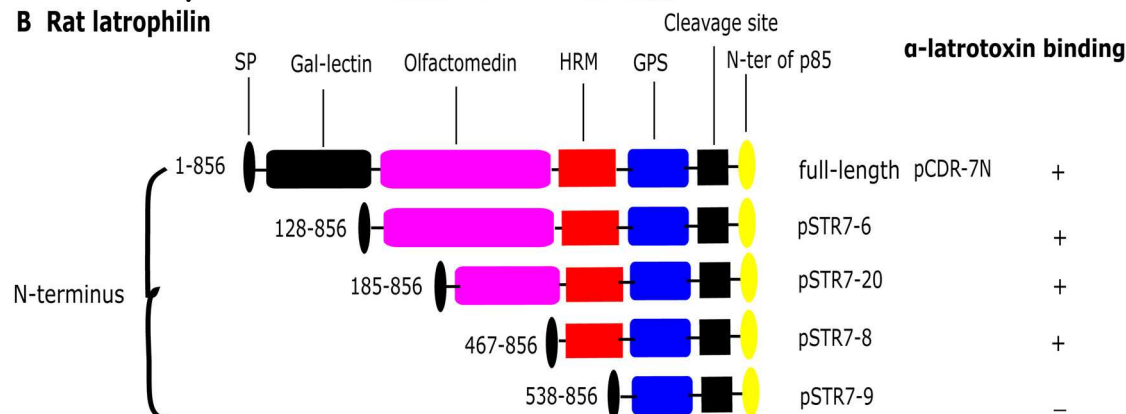

**Figure 4.2 Effect of latrophilin in *C.elegans* lat-1 (ok1465) worms and mammals.** A shows *C.elegans* lat-1. The 1st structure shows full-length lat-1a fused to green fluorescent protein (GFP) made up of signal peptide domain, galactose-binding lectin domain (GBL), hormone receptor motif domain (HRM), G-protein couple receptor proteolysis motif domain (GPS), seven transmembrane domain (TM7), area of four cysteine domain. 2nd structure shows truncation of 4xCys at amino acid 870. 3rd structure shows truncation of TM7 at amino acid 790. 4th structure shows truncation of TM1 at amino acid 579. 5th structure is ΔGBL that shows truncation of domains at amino acid between 62-147. 6th structure is ΔGBL that shows truncation of domains between 62-250. 7th structure is ΔN that shows truncation of amino acid between 62-487. Each truncation construct shows its effect with respect to rescue of lethality or defecation cycle and combined latrotoxins. For lethality and defecation, + means full rescue, +/- means partial rescue, - means no rescue, \* means not tested. For combined latrotoxins, + means 100% lethality at ~4ng/ml, +/- means 50% lethality at 400μg/ml, \*means not tested. B shows SP, GBL, HRM, GPS on the rat latrophilin sequence as present on *C.elegans* lat-1. 1st structure shows the full-length of N-terminus rat latrophilin between amino acids 1-856. 2nd structure shows deletion of domains between amino acid 538-856. 3rd structure shows deletion of domains between amino acid 185-856. 4th structure shows deletion of domains between amino acid 394-856. 5th structure shows deletion of domains between amino acid 538-856. 6th structure shows deletion of domains between amino acids 467-705. Each truncation construct shows its effect with respect to α-latrotoxin binding. + means toxin binding, - means no toxin binding. The figure 4.2B is reproduced from [5].

**Section 4.7.2 The role of lat-1a C-terminus in combined latrotoxin toxicity**

The role of intracellular signalling in the mechanism of action of lat-1 was investigated with worms transgenic for truncated C-terminus lat-1a constructs, which were tested for the toxicity of combined latrotoxins in transgenic worms. The 4xCys worms showed similar sensitivity to wild-type worms ( $LD_{50} \sim 40$  ng/ml), indicating the region of the C-terminus distal to the 4xCys domain is not required for signalling the toxicity of combined latrotoxins, consistent with the finding that the 4xCys domain is not required for defecation cycle defect in lat-1(ok1465) worms. However, deletion of the 4xCys domain in C-terminus lat-1a resulting to TM7 construct yielded TM7 worms that were  $\sim 10^4$ -fold less sensitive to combined latrotoxins than 4xCys worms, consistent with the finding that the 4xCys domain is required for the rescue of lat-1(ok1465) worms (Figure 4.2A). Therefore, 4xCys domain is important for the toxicity of combined latrotoxins.

This report showed that C-terminus of lat-1a is required for the toxicity of combined latrotoxins, and it suggests the ability of lat-1 gene to trigger signal through its C-terminal domain is required for the toxic action of combined latrotoxins. This finding is in contrast to the hypothesis that suggests latrophilin merely acts as a tether to signalling action of combined latrotoxins, and that intracellular signalling from lat-1 is not relevant [2], [1], [110], [127]. Fig 1.2 described the model that signalling is not relevant to trigger exocytosis when  $\alpha$ -latrotoxin binds to latrophilin, whereas these data suggest that lat-1 gene is important for signalling action of toxicity of combined latrotoxins. Sugita and his colleagues (1998) have shown that latrophilin (CIRL) as a G-protein coupled receptor is not required for signalling to stimulate exocytosis during  $\alpha$ -latrotoxin receptor binding, but rather recruit toxin to the membrane without participating in neurotransmitter release. Moreover, this finding supports the idea that latrophilin mediates the action of  $\alpha$ -latrotoxin through intracellular signalling [128], [126], [125]. Volynski et al (2000) had shown that it may be possible that latrophilin is involved in intracellular signalling of pore formation



but its mechanism of action remains unclear. However, this finding in *C.elegans* showed the importance of intracellular signalling of C-terminal lat-1a in the rescue and toxicity of combined latrotoxins for transgenic lat-1 worms.

### **Section 4.7.3 The role of lat-1a N-terminus in combined latrotoxin toxicity**

The N-terminal of mammalian latrophilin is an important ligand-binding for  $\alpha$ -latrotoxin, therefore, it is important to identify the regions within N-terminal of *C.elegans* lat-1 that are required for the toxicity of combined latrotoxins. The  $\Delta$ GBL worms were sensitive to the toxicity of combined latrotoxins at LD<sub>50</sub> 4 ng/ml while  $\Delta$ HRM worms were only sensitive at 400  $\mu$ g/ml, 10<sup>5</sup>-fold greater than  $\Delta$ GBL worms. These data showed that deletion of the galactose-binding lectin domain (GBL) of the N-terminus lat-1a did not affect the sensitivity for the toxicity of combined latrotoxins, which is consistent with the finding that showed deletion of GBL domain is not required for the binding of toxin [5], suggesting the GBL domain by itself is not essential for the toxin binding activity (Figure 4.2A&B). Deletion of hormone receptor motif domain (HRM) of N-terminus lat-1a showed a reduced sensitivity to combined latrotoxins by  $\sim$ 10<sup>5</sup>-fold, thus indicating the importance of HRM in the toxicity of combined latrotoxins. This finding is consistent with data that requires HRM domain for the rescue of lat-1(ok1465) worms, and the fact that deletion of the rat latrophilin HRM ablates the ability of the protein to bind to  $\alpha$ -latrotoxin [5]. Therefore, the HRM domain is important for the rescue of the lat-1 animal lethality and toxicity of combined latrotoxins, and the data of Krasnoperov (1999) suggests that this is because the HRM binds to the latrotoxins. It is likely that the GBL and HRM domains have distinct functions, as the GBL domain is not required for the toxicity of combined latrotoxins, whereas the HRM domain is required for the toxicity of combined latrotoxins. In agreement, deletion of the GBL domain alone failed to fully rescue lat-1 (ok1465) worms, showing that this regions has a role in the rescue of lat-1 animals. The deletion of both the GBL and HRM domain drastically reduced rescue of lat-1 worms, and in conjunction with the greatly reduced toxicity

of combined latrotoxins in  $\Delta$ HRM worms, suggests that the HRM is the ligand-binding domain of lat-1a for both the endogenous ligand(s) and latrotoxins.

#### **Section 4.7.4 The toxicity of Potassium cyanide (KCN)**

All transgenic animals including wild-type and lat-1(ok1465) worms were injected with KCN to disqualify the possibility of non-specificity of lat-1 constructs for the toxicity of combined latrotoxins. This control experiment is important in order to understand whether worm lethality or survival was a result of lat-1 gene specific for the toxicity of combined latrotoxins or absence of lat-1 gene conferred resistance on the toxicity of combined latrotoxins. However, these data showed that all transgenic animals, lat-1 animals and wild-type worms were equally sensitive to chemical toxicity, and that the various lat-1 constructs do not confer any non-specific sensitivity to chemical toxins. By contrast, the specific sensitivity to of these various constructs to combined latrotoxins must be due to a specific interaction between lat-1a and combined latrotoxins, and given the known interaction of mammalian latrophilins with  $\alpha$ -latrotoxin, this seems a likely possibility.

#### **Section 4.8 Future work**

This research has provided great understanding about the role of the lat-1 gene in lat-1(ok1465) worms and more importantly to the role of latrophilin as a receptor of combined latrotoxins. It is also very important to investigate other related genes that perform similar functions to the latrophilin either in *C.elegans* or in mammals such as rat. Some of the future works that are expected to be carried out are described. The lethality of the lat-1(ok1465) shows an important role for the endogenous lat-1 gene, and it would be interesting to see if this is conserved with mammalian latrophilins, *e.g.* by testing to see if rat lat-1 receptor under the control of *C.elegans* lat-1 promoter rescues lat-1(ok1465) animals and confers susceptibility to combined latrotoxins. The site of action of latrophilin is unclear, and given that lat-1 gene is expressed in gut cells, it

will be important to express the *lat-1a::gfp* fusion under the control of gut-specific promoter, to test for rescue of *lat-1* animals and susceptibility of combined latrotoxins. Finally, the *C. elegans* *lat-1* protein is not characterised, and detecting this protein by Western blotting will help to understand the properties associated with *lat-1* protein and provide more clues with respect to the function of *lat-1* gene.

## References

1. Sugita, S., et al., *alpha-Latrotoxin receptor CIRL/latrophilin 1 (CL1) defines an unusual family of ubiquitous G-protein-linked receptors. G-protein coupling not required for triggering exocytosis.* J Biol Chem, 1998. **273**(49): p. 32715-24.
2. Sudhof, T.C., *alpha-Latrotoxin and its receptors: neurexins and CIRL/latrophilins.* Annu Rev Neurosci, 2001. **24**: p. 933-62.
3. Kiyatkin, N., I. Dulubova, and E. Grishin, *Cloning and structural analysis of alpha-latroinsectotoxin cDNA. Abundance of ankyrin-like repeats.* Eur J Biochem, 1993. **213**(1): p. 121-7.
4. Saibil, H.R., *The black widow's versatile venom.* Nat Struct Biol, 2000. **7**(1): p. 3-4.
5. Krasnoperov, V., et al., *Structural requirements for alpha-latrotoxin binding and alpha-latrotoxin-stimulated secretion. A study with calcium-independent receptor of alpha-latrotoxin (CIRL) deletion mutants.* J Biol Chem, 1999. **274**(6): p. 3590-6.
6. Davletov, B.A., et al., *Isolation and biochemical characterization of a Ca<sup>2+</sup>-independent alpha-latrotoxin-binding protein.* J Biol Chem, 1996. **271**(38): p. 23239-45.
7. Krasnoperov, V.G., et al., *alpha-Latrotoxin stimulates exocytosis by the interaction with a neuronal G-protein-coupled receptor.* Neuron, 1997. **18**(6): p. 925-37.
8. Henkel, A.W. and S. Sankaranarayanan, *Mechanisms of alpha-latrotoxin action.* Cell Tissue Res, 1999. **296**(2): p. 229-33.
9. Harmar, A.J., *Family-B G-protein-coupled receptors.* Genome Biol, 2001. **2**(12): p. REVIEWS3013.
10. Snyder, D.A., et al., *Olfactomedin: purification, characterization, and localization of a novel olfactory glycoprotein.* Biochemistry, 1991. **30**(38): p. 9143-53.
11. Shiratsuchi, T., et al., *Cloning and characterization of BAI2 and BAI3, novel genes homologous to brain-specific angiogenesis inhibitor 1 (BAI1).* Cytogenet Cell Genet, 1997. **79**(1-2): p. 103-8.
12. Chang, G.W., et al., *Proteolytic cleavage of the EMR2 receptor requires both the extracellular stalk and the GPS motif.* FEBS Lett, 2003. **547**(1-3): p. 145-50.

13. Ushkaryov, Y.A., K.E. Volynski, and A.C. Ashton, *The multiple actions of black widow spider toxins and their selective use in neurosecretion studies*. *Toxicon*, 2004. **43**(5): p. 527-42.
14. Ichtchenko, K., et al., *A novel ubiquitously expressed alpha-latrotoxin receptor is a member of the CIRL family of G-protein-coupled receptors*. *J Biol Chem*, 1999. **274**(9): p. 5491-8.
15. Matsushita, H., V.G. Lelianova, and Y.A. Ushkaryov, *The latrophilin family: multiply spliced G protein-coupled receptors with differential tissue distribution*. *FEBS Lett*, 1999. **443**(3): p. 348-52.
16. Davletov, B.A., et al., *High affinity binding of alpha-latrotoxin to recombinant neurexin I alpha*. *J Biol Chem*, 1995. **270**(41): p. 23903-5.
17. Khvotchev, M., G. Lonart, and T.C. Sudhof, *Role of calcium in neurotransmitter release evoked by alpha-latrotoxin or hypertonic sucrose*. *Neuroscience*, 2000. **101**(3): p. 793-802.
18. Sugita, S., M. Khvochtev, and T.C. Sudhof, *Neurexins are functional alpha-latrotoxin receptors*. *Neuron*, 1999. **22**(3): p. 489-96.
19. Petrenko, A.G., et al., *Isolation and properties of the alpha-latrotoxin receptor*. *Embo J*, 1990. **9**(6): p. 2023-7.
20. Ushkaryov, Y.A., et al., *Neurexins: synaptic cell surface proteins related to the alpha-latrotoxin receptor and laminin*. *Science*, 1992. **257**(5066): p. 50-6.
21. Missler, M., R.E. Hammer, and T.C. Sudhof, *Neurexophilin binding to alpha-neurexins. A single LNS domain functions as an independently folding ligand-binding unit*. *J Biol Chem*, 1998. **273**(52): p. 34716-23.
22. Tabuchi, K. and T.C. Sudhof, *Structure and evolution of neurexin genes: insight into the mechanism of alternative splicing*. *Genomics*, 2002. **79**(6): p. 849-59.
23. Hata, Y., S. Butz, and T.C. Sudhof, *CASK: a novel dlg/PSD95 homolog with an N-terminal calmodulin-dependent protein kinase domain identified by interaction with neurexins*. *J Neurosci*, 1996. **16**(8): p. 2488-94.
24. Krasnoperov, V., et al., *Protein-tyrosine phosphatase-sigma is a novel member of the functional family of alpha-latrotoxin receptors*. *J Biol Chem*, 2002. **277**(39): p. 35887-95.

25. Meathrel, K., et al., *Protein tyrosine phosphatase sigma-deficient mice show aberrant cytoarchitecture and structural abnormalities in the central nervous system*. J Neurosci Res, 2002. **70**(1): p. 24-35.
26. Yan, H., et al., *A novel receptor tyrosine phosphatase-sigma that is highly expressed in the nervous system*. J Biol Chem, 1993. **268**(33): p. 24880-6.
27. Pan, M.G., et al., *Cloning and expression of two structurally distinct receptor-linked protein-tyrosine phosphatases generated by RNA processing from a single gene*. J Biol Chem, 1993. **268**(26): p. 19284-91.
28. Sapienza, P.S., et al., *Receptor protein tyrosine phosphatase sigma inhibits axon regrowth in the adult injured CNS*. Mol Cell Neurosci, 2005. **28**(4): p. 625-35.
29. Lajus, S. and J. Lang, *Splice variant 3, but not 2 of receptor protein-tyrosine phosphatase sigma can mediate stimulation of insulin-secretion by alpha-latrotoxin*. J Cell Biochem, 2006. **98**(6): p. 1552-9.
30. Lee, S., et al., *Dimerization of protein tyrosine phosphatase sigma governs both ligand binding and isoform specificity*. Mol Cell Biol, 2007. **27**(5): p. 1795-808.
31. Rash, L.D. and W.C. Hodgson, *Pharmacology and biochemistry of spider venoms*. Toxicon, 2002. **40**(3): p. 225-54.
32. Garb, J.E., A. Gonzalez, and R.G. Gillespie, *The black widow spider genus Latrodectus (Araneae: Theridiidae): phylogeny, biogeography, and invasion history*. Mol Phylogenet Evol, 2004. **31**(3): p. 1127-42.
33. Litovitz, T.L., et al., *1997 annual report of the American Association of Poison Control Centers Toxic Exposure Surveillance System*. Am J Emerg Med, 1998. **16**(5): p. 443-97.
34. Jackson, H. and T.N. Parks, *Spider toxins: recent applications in neurobiology*. Annu Rev Neurosci, 1989. **12**: p. 405-14.
35. Maretic, Z., *Latrodectism: variations in clinical manifestations provoked by Latrodectus species of spiders*. Toxicon, 1983. **21**(4): p. 457-66.
36. Muller, G.J., *Black and brown widow spider bites in South Africa. A series of 45 cases*. S Afr Med J, 1993. **83**(6): p. 399-405.
37. Zukowski, C.W., *Black widow spider bite*. J Am Board Fam Pract, 1993. **6**(3): p. 279-81.

38. Clark, R.F., et al., *Clinical presentation and treatment of black widow spider envenomation: a review of 163 cases*. *Ann Emerg Med*, 1992. **21**(7): p. 782-7.
39. Fritz, L.C., M.C. Tzen, and A. Mauro, *Different components of black widow spider venom mediate transmitter release at vertebrate and lobster neuromuscular junctions*. *Nature*, 1980. **283**(5746): p. 486-7.
40. Frontali, N., et al., *Purification from black widow spider venom of a protein factor causing the depletion of synaptic vesicles at neuromuscular junctions*. *J Cell Biol*, 1976. **68**(3): p. 462-79.
41. Magazanik, L.G., et al., *Selective presynaptic insectotoxin (alpha-latroinsectotoxin) isolated from black widow spider venom*. *Neuroscience*, 1992. **46**(1): p. 181-8.
42. Schiavo, G., M. Matteoli, and C. Montecucco, *Neurotoxins affecting neuroexocytosis*. *Physiol Rev*, 2000. **80**(2): p. 717-66.
43. Grishin, E., *Polypeptide neurotoxins from spider venoms*. *Eur J Biochem*, 1999. **264**(2): p. 276-80.
44. Grishin, E.V., *Black widow spider toxins: the present and the future*. *Toxicon*, 1998. **36**(11): p. 1693-701.
45. Krasnoperov, V.G., O.G. Shamotienko, and E.V. Grishin, *[Isolation and properties of insect-specific neurotoxins from venoms of the spider *Lactodectus mactans tredecimguttatus*]*. *Bioorg Khim*, 1990. **16**(8): p. 1138-40.
46. Dulubova, I.E., et al., *Cloning and structure of delta-latroinsectotoxin, a novel insect-specific member of the latrotoxin family: functional expression requires C-terminal truncation*. *J Biol Chem*, 1996. **271**(13): p. 7535-43.
47. Nicholson, G.M. and A. Graudins, *Spiders of medical importance in the Asia-Pacific: atracotoxin, latrotoxin and related spider neurotoxins*. *Clin Exp Pharmacol Physiol*, 2002. **29**(9): p. 785-94.
48. Ashton, A.C., et al., *Tetramerisation of alpha-latrotoxin by divalent cations is responsible for toxin-induced non-vesicular release and contributes to the Ca(2+)-dependent vesicular exocytosis from synaptosomes*. *Biochimie*, 2000. **82**(5): p. 453-68.
49. Orlova, E.V., et al., *Structure of alpha-latrotoxin oligomers reveals that divalent cation-dependent tetramers form membrane pores*. *Nat Struct Biol*, 2000. **7**(1): p. 48-53.

50. Burmistrov, Y.M., Z.P. Shuranova, and N.I. Artiukhina, *Effects of black widow spider venom and latrocrustatoxin on crustacean nerve cells: electrophysiological and ultrastructural study*. Gen Pharmacol, 1997. **28**(1): p. 159-66.
51. Elrick, D.B. and M.P. Charlton, *alpha-latrocrustatoxin increases neurotransmitter release by activating a calcium influx pathway at crayfish neuromuscular junction*. J Neurophysiol, 1999. **82**(6): p. 3550-62.
52. Culetto, E. and D.B. Sattelle, *A role for Caenorhabditis elegans in understanding the function and interactions of human disease genes*. Hum Mol Genet, 2000. **9**(6): p. 869-77.
53. Schwarz, E.M., et al., *WormBase: better software, richer content*. Nucleic Acids Res, 2006. **34**(Database issue): p. D475-8.
54. Brenner, S., *The genetics of Caenorhabditis elegans*. Genetics, 1974. **77**(1): p. 71-94.
55. Francis, M.M., J.E. Mellem, and A.V. Maricq, *Bridging the gap between genes and behavior: recent advances in the electrophysiological analysis of neural function in Caenorhabditis elegans*. Trends Neurosci, 2003. **26**(2): p. 90-9.
56. Boulton, S.J., et al., *Combined functional genomic maps of the C. elegans DNA damage response*. Science, 2002. **295**(5552): p. 127-31.
57. Hodgkin, J., *Sex, cell death, and the genome of C. elegans*. Cell, 1999. **98**(3): p. 277-80.
58. Aboobaker, A.A. and M.L. Blaxter, *Medical significance of Caenorhabditis elegans*. Ann Med, 2000. **32**(1): p. 23-30.
59. Wood, W.B., *Determination of pattern and fate in early embryos of Caenorhabditis elegans*. Dev Biol (N Y 1985), 1988. **5**: p. 57-78.
60. Kenyon, C., *The nematode Caenorhabditis elegans*. Science, 1988. **240**(4858): p. 1448-53.
61. Albertson, D.G. and J.N. Thomson, *The pharynx of Caenorhabditis elegans*. Philos Trans R Soc Lond B Biol Sci, 1976. **275**(938): p. 299-325.
62. Avery, L. and H.R. Horvitz, *Pharyngeal pumping continues after laser killing of the pharyngeal nervous system of C. elegans*. Neuron, 1989. **3**(4): p. 473-85.
63. Branicky, R. and S. Hekimi, *What keeps C. elegans regular: the genetics of defecation*. Trends Genet, 2006. **22**(10): p. 571-9.



64. Liu, D.W. and J.H. Thomas, *Regulation of a periodic motor program in C. elegans*. J Neurosci, 1994. **14**(4): p. 1953-62.
65. Thomas, J.H., *Genetic analysis of defecation in Caenorhabditis elegans*. Genetics, 1990. **124**(4): p. 855-72.
66. Reiner, D.J. and J.H. Thomas, *Reversal of a muscle response to GABA during C. elegans male development*. J Neurosci, 1995. **15**(9): p. 6094-102.
67. Sulston, J.E., *Neuronal cell lineages in the nematode Caenorhabditis elegans*. Cold Spring Harb Symp Quant Biol, 1983. **48 Pt 2**: p. 443-52.
68. Sulston, J.E. and H.R. Horvitz, *Post-embryonic cell lineages of the nematode, Caenorhabditis elegans*. Dev Biol, 1977. **56**(1): p. 110-56.
69. White, J.G., et al., *The structure of the ventral nerve cord of Caenorhabditis elegans*. Philos Trans R Soc Lond B Biol Sci, 1976. **275**(938): p. 327-48.
70. Xue, D., et al., *Regulation of the mec-3 gene by the C.elegans homeoproteins UNC-86 and MEC-3*. Embo J, 1992. **11**(13): p. 4969-79.
71. Miller, D.M., et al., *C. elegans unc-4 gene encodes a homeodomain protein that determines the pattern of synaptic input to specific motor neurons*. Nature, 1992. **355**(6363): p. 841-5.
72. Way, J.C. and M. Chalfie, *The mec-3 gene of Caenorhabditis elegans requires its own product for maintained expression and is expressed in three neuronal cell types*. Genes Dev, 1989. **3**(12A): p. 1823-33.
73. Richmond, J., *Synaptic function*. WormBook, 2005: p. 1-14.
74. Nonet, M.L., et al., *Synaptic function is impaired but not eliminated in C. elegans mutants lacking synaptotagmin*. Cell, 1993. **73**(7): p. 1291-305.
75. Harris, T.W., K. Schuske, and E.M. Jorgensen, *Studies of synaptic vesicle endocytosis in the nematode C. elegans*. Traffic, 2001. **2**(9): p. 597-605.
76. Sudhof, T.C., *The synaptic vesicle cycle: a cascade of protein-protein interactions*. Nature, 1995. **375**(6533): p. 645-53.
77. Miller, K.G., et al., *A genetic selection for Caenorhabditis elegans synaptic transmission mutants*. Proc Natl Acad Sci U S A, 1996. **93**(22): p. 12593-8.
78. Nguyen, M., et al., *Caenorhabditis elegans mutants resistant to inhibitors of acetylcholinesterase*. Genetics, 1995. **140**(2): p. 527-35.

79. Rand, J.B. and R.L. Russell, *Molecular basis of drug-resistance mutations in C. elegans*. *Psychopharmacol Bull*, 1985. **21**(3): p. 623-30.
80. Hosono, R., T. Sassa, and S. Kuno, *Mutations affecting acetylcholine levels in the nematode Caenorhabditis elegans*. *J Neurochem*, 1987. **49**(6): p. 1820-3.
81. Brose, N., et al., *Synaptotagmin: a calcium sensor on the synaptic vesicle surface*. *Science*, 1992. **256**(5059): p. 1021-5.
82. Koh, T.W. and H.J. Bellen, *Synaptotagmin I, a Ca<sup>2+</sup> sensor for neurotransmitter release*. *Trends Neurosci*, 2003. **26**(8): p. 413-22.
83. Petrenko, A.G., et al., *Binding of synaptotagmin to the alpha-latrotoxin receptor implicates both in synaptic vesicle exocytosis*. *Nature*, 1991. **353**(6339): p. 65-8.
84. DiAntonio, A. and T.L. Schwarz, *The effect on synaptic physiology of synaptotagmin mutations in Drosophila*. *Neuron*, 1994. **12**(4): p. 909-20.
85. Geppert, M., et al., *Synaptotagmin I: a major Ca<sup>2+</sup> sensor for transmitter release at a central synapse*. *Cell*, 1994. **79**(4): p. 717-27.
86. Mee, C.J., et al., *Latrophilin is required for toxicity of black widow spider venom in Caenorhabditis elegans*. *Biochem J*, 2004. **378**(Pt 1): p. 185-91.
87. Harder, A., et al., *Cyclooctadepsipeptides--an anthelmintically active class of compounds exhibiting a novel mode of action*. *Int J Antimicrob Agents*, 2003. **22**(3): p. 318-31.
88. Willson, J., et al., *Latrotoxin receptor signaling engages the UNC-13-dependent vesicle-priming pathway in C. elegans*. *Curr Biol*, 2004. **14**(15): p. 1374-9.
89. Fire, A., *Integrative transformation of Caenorhabditis elegans*. *Embo J*, 1986. **5**(10): p. 2673-2680.
90. Mello, C. and A. Fire, *DNA transformation*. *Methods Cell Biol*, 1995. **48**: p. 451-82.
91. Mello, C.C., et al., *Efficient gene transfer in C.elegans: extrachromosomal maintenance and integration of transforming sequences*. *Embo J*, 1991. **10**(12): p. 3959-70.
92. Stinchcomb, D.T., et al., *Extrachromosomal DNA transformation of Caenorhabditis elegans*. *Mol Cell Biol*, 1985. **5**(12): p. 3484-96.

93. Berezikov, E., C.I. Bargmann, and R.H. Plasterk, *Homologous gene targeting in Caenorhabditis elegans by biolistic transformation*. Nucleic Acids Res, 2004. **32**(4): p. e40.
94. Anderson, P. and S. Brenner, *A selection for myosin heavy chain mutants in the nematode Caenorhabditis elegans*. Proc Natl Acad Sci U S A, 1984. **81**(14): p. 4470-4.
95. Rizzo, M.A., et al., *An improved cyan fluorescent protein variant useful for FRET*. Nat Biotechnol, 2004. **22**(4): p. 445-9.
96. Edgley, M.L. and D.L. Riddle, *LG II balancer chromosomes in Caenorhabditis elegans: mT1(II;III) and the mIn1 set of dominantly and recessively marked inversions*. Mol Genet Genomics, 2001. **266**(3): p. 385-95.
97. Fire, A., S.W. Harrison, and D. Dixon, *A modular set of lacZ fusion vectors for studying gene expression in Caenorhabditis elegans*. Gene, 1990. **93**(2): p. 189-98.
98. Iwasaki, K., D.W. Liu, and J.H. Thomas, *Genes that control a temperature-compensated ultradian clock in Caenorhabditis elegans*. Proc Natl Acad Sci U S A, 1995. **92**(22): p. 10317-21.
99. Park, B.J., et al., *Calreticulin, a calcium-binding molecular chaperone, is required for stress response and fertility in Caenorhabditis elegans*. Mol Biol Cell, 2001. **12**(9): p. 2835-45.
100. Iwasaki, K., et al., *aex-3 encodes a novel regulator of presynaptic activity in C. elegans*. Neuron, 1997. **18**(4): p. 613-22.
101. Trappe, R., et al., *The Caenorhabditis elegans ortholog of human PHF5a shows a muscle-specific expression domain and is essential for C. elegans morphogenetic development*. Biochem Biophys Res Commun, 2002. **297**(4): p. 1049-57.
102. Qadota, H., et al., *Establishment of a tissue-specific RNAi system in C. elegans*. Gene, 2007. **400**(1-2): p. 166-73.
103. Kawasaki, I., et al., *PGL-1, a predicted RNA-binding component of germ granules, is essential for fertility in C. elegans*. Cell, 1998. **94**(5): p. 635-45.
104. Chalfie, M., et al., *Green fluorescent protein as a marker for gene expression*. Science, 1994. **263**(5148): p. 802-5.

105. Graham, P.L., et al., *Type IV collagen is detectable in most, but not all, basement membranes of Caenorhabditis elegans and assembles on tissues that do not express it.* J Cell Biol, 1997. **137**(5): p. 1171-83.
106. Hashmi, S., et al., *Cathepsin L is essential for embryogenesis and development of Caenorhabditis elegans.* J Biol Chem, 2002. **277**(5): p. 3477-86.
107. Dent, J.A. and M. Han, *Post-embryonic expression pattern of C. elegans let-60 ras reporter constructs.* Mech Dev, 1998. **72**(1-2): p. 179-82.
108. Ji, Q., et al., *CeRh1 (rhr-1) is a dominant Rhesus gene essential for embryonic development and hypodermal function in Caenorhabditis elegans.* Proc Natl Acad Sci U S A, 2006. **103**(15): p. 5881-6.
109. Katsura, I., et al., *Isolation, characterization and epistasis of fluoride-resistant mutants of Caenorhabditis elegans.* Genetics, 1994. **136**(1): p. 145-54.
110. Ichtchenko, K., et al., *alpha-latrotoxin action probed with recombinant toxin: receptors recruit alpha-latrotoxin but do not transduce an exocytotic signal.* Embo J, 1998. **17**(21): p. 6188-99.
111. Clark, D.V., et al., *Molecular cloning and characterization of the dpy-20 gene of Caenorhabditis elegans.* Mol Gen Genet, 1995. **247**(3): p. 367-78.
112. Morris, A.J. and C.C. Malbon, *Physiological regulation of G protein-linked signaling.* Physiol Rev, 1999. **79**(4): p. 1373-430.
113. Pupillo, M., et al., *cAMP receptor and G-protein interactions control development in Dictyostelium.* Cold Spring Harb Symp Quant Biol, 1988. **53 Pt 2**: p. 657-65.
114. Lyons, J., et al., *Two G protein oncogenes in human endocrine tumors.* Science, 1990. **249**(4969): p. 655-9.
115. Offermanns, S., et al., *Embryonic cardiomyocyte hypoplasia and craniofacial defects in G alpha q/G alpha 11-mutant mice.* Embo J, 1998. **17**(15): p. 4304-12.
116. Zwaal, R.R., et al., *G proteins are required for spatial orientation of early cell cleavages in C. elegans embryos.* Cell, 1996. **86**(4): p. 619-29.
117. Liebmann, C., *G protein-coupled receptors and their signaling pathways: classical therapeutic targets susceptible to novel therapeutic concepts.* Curr Pharm Des, 2004. **10**(16): p. 1937-58.

118. Neumann, J.M., et al., *Class-B GPCR activation: is ligand helix-capping the key?* Trends Biochem Sci, 2008. **33**(7): p. 314-9.
119. Vakonakis, I., et al., *Solution structure and sugar-binding mechanism of mouse latrophilin-1 RBL: a 7TM receptor-attached lectin-like domain.* Structure, 2008. **16**(6): p. 944-53.
120. Lelianova, V.G., et al., *Alpha-latrotoxin receptor, latrophilin, is a novel member of the secretin family of G protein-coupled receptors.* J Biol Chem, 1997. **272**(34): p. 21504-8.
121. Kreienkamp, H.J., et al., *The calcium-independent receptor for alpha-latrotoxin from human and rodent brains interacts with members of the ProSAP/SSTRIP/Shank family of multidomain proteins.* J Biol Chem, 2000. **275**(42): p. 32387-90.
122. Sassi, H.E., et al., *Gene CATCHR--gene cloning and tagging for Caenorhabditis elegans using yeast homologous recombination: a novel approach for the analysis of gene expression.* Nucleic Acids Res, 2005. **33**(18): p. e163.
123. Haitina, T., et al., *Expression profile of the entire family of Adhesion G protein-coupled receptors in mouse and rat.* BMC Neurosci, 2008. **9**: p. 43.
124. Lang, J., et al., *Ca<sup>2+</sup>-independent insulin exocytosis induced by alpha-latrotoxin requires latrophilin, a G protein-coupled receptor.* Embo J, 1998. **17**(3): p. 648-57.
125. Davletov, B.A., et al., *Vesicle exocytosis stimulated by alpha-latrotoxin is mediated by latrophilin and requires both external and stored Ca<sup>2+</sup>.* Embo J, 1998. **17**(14): p. 3909-20.
126. Volynski, K.E., et al., *Latrophilin, neurexin, and their signaling-deficient mutants facilitate alpha -latrotoxin insertion into membranes but are not involved in pore formation.* J Biol Chem, 2000. **275**(52): p. 41175-83.
127. Li, G., et al., *N-terminal insertion and C-terminal ankyrin-like repeats of alpha-latrotoxin are critical for Ca<sup>2+</sup>-dependent exocytosis.* J Neurosci, 2005. **25**(44): p. 10188-97.
128. Capogna, M., et al., *The alpha-latrotoxin mutant LTXN4C enhances spontaneous and evoked transmitter release in CA3 pyramidal neurons.* J Neurosci, 2003. **23**(10): p. 4044-53.

129. De Camilli, P. and K. Takei, *Molecular mechanisms in synaptic vesicle endocytosis and recycling*. Neuron, 1996. **16**(3): p. 481-6.
130. Lelianova, V.G., et al., *Alpha-latrotoxin receptor, latrophilin, is a novel member of the secretin family of G protein-coupled receptors*. J Biol Chem, 1997. **272**(34): p. 21504-8.