

Fowle, Kenneth (2003) The Use Of Computer Graphics And Visualisation (From Reconstruction To Training) For The Resource Sector Of Western Australia. PhD thesis, University of Nottingham.

**Access from the University of Nottingham repository:**

<http://eprints.nottingham.ac.uk/10044/1/kensthesis.pdf>

**Copyright and reuse:**

The Nottingham ePrints service makes this work by researchers of the University of Nottingham available open access under the following conditions.

This article is made available under the University of Nottingham End User licence and may be reused according to the conditions of the licence. For more details see:  
[http://eprints.nottingham.ac.uk/end\\_user\\_agreement.pdf](http://eprints.nottingham.ac.uk/end_user_agreement.pdf)

**A note on versions:**

The version presented here may differ from the published version or from the version of record. If you wish to cite this item you are advised to consult the publisher's version. Please see the repository url above for details on accessing the published version and note that access may require a subscription.

For more information, please contact [eprints@nottingham.ac.uk](mailto:eprints@nottingham.ac.uk)

University of Nottingham

School of Chemical, Environmental and Mining Engineering



**THE USE OF COMPUTER GRAPHICS AND VISUALISATION  
(FROM RECONSTRUCTION TO TRAINING) FOR THE  
RESOURCE SECTOR OF WESTERN AUSTRALIA**

**by**

**Kenneth G. E. Fowle**

Thesis submitted to The University of Nottingham  
for the degree of Doctor of Philosophy, April 2003

## **Abstract**

The minerals and energy sector can rightly be classified as comprising an extremely hazardous working environment in which numerous situations exist for accidents and incidents involving personnel and equipment to occur.

Accidents are often explained by what are referred to as 'human factor'. The often used explanation, 'technical-failure', gives the impression that technology lives a life of its own without human intervention. However, technical failure often occurs because of human errors in construction, installation, maintenance or operation. It is the person who triggers the risks who is made morally (and sometime legally) responsible. When an operator makes a mistake (an active error) he or she is personally blamed. When a designer or constructor makes a mistake, or when cheap or inferior equipment is bought, or when maintenance is faulty, the responsibility is depersonalised and it becomes a 'technology' fault (Sunderström-Frisk, 1998).

This research examines ways of using expert information using computer graphics and visualisation to produce visual applications that demonstrate and explain, but also have the added ability to teach the user or viewer, with the intent to assess their competency.

Today's technology provides educators, students, professional bodies and the general public access to large amounts of information in a visual form. We repackage technical literature and data as movies and videos for audiences to view, instead of reading the information. Understanding may be achieved rapidly instead of taking days, weeks or months. From a visual presentation the viewers absorb information, which is easy to retain.

The reconstructions discussed in this research concern the minerals and energy sector of Western Australia. They not only show what went wrong but can also be customised to demonstrate how to prevent an accident/incident. The benefits of this to industry is primarily: the ability to reuse the reconstruction instead of closing down a production line that cost the company and industry many thousands of dollars, and no lives are exposed to hazardous environments while examining the reconstruction for investigation or training purposes.

## Acknowledgements

The author would like to express his sincere thanks to the following:

**Mr Brian Paterson** – Managing Director of Central TAFE for his vision in this area and support.

**Mr John Timms** – Former General Manager/Director R&D at Central TAFE for initially employing me to undertake this project and the support and encouragement (kick up the bum) he provided in its success.

The ‘olde’ **Department of Minerals and Energy (DME)** (now Dept. of Industry and Resources) for granting me a secondment to pursue this PhD project. **Mr Tim McGovern** - General Manager Computer Services (retired), **Dr Colin Branch** - Deputy Director General (retired), **Mr Jim Torlach**, **Mr Martin Knee**, **Mrs K Watkins**, **Mr P Burke**, and **Mr T Smurthwaite** for their support and assistance.

**Professor Bryan Denby** and **Dr Damian Schofield** who after many meetings at Western Australian wineries, convinced me to undertake a PhD. (Who says business lunches are non-productive). Also their ‘mateship’ and help through out this project e.g. Bryan for accepting and supporting my application, Damian for his advice and as my supervisor .

The **Squelch’s**, **Dr Andrew** for his support (Tim-Tams) and advice, and **Professor Joan** for her persistent inquiries of “*is it finished*”.

**Mr Ken Steele** for his continual support, expert advice, encouragement and the many ideas he shared ... ‘Thanks Echo 1’.

**Petra Bowling** and **Ross Spencer** for friendship and providing administration support (that now costs 5 percent) and the many humorous e-mails exchanged.

**Mike Annear** - Senior Animator/Modeller (Dare-Devil and Paraglider) and **Akos Bruz** Video Producer (Wine and Sausage maker) for their friendship and support in providing technical advice, Hungarian words, reasons why I should jump off a cliff and the occasional drinking partners.

The **AIMS unit personnel** must also be commended for allowing this Australian to come and go into their inner sanctum and for introducing me to the Nottingham cuisine and nightlife, especially **THE IRISH**.

Certain UoN people need to be named:

**Andy Burton** (now Dr) for showing me the IRISH and how the English BBQ

**Beverly Denby** (nee Blackburn) for home cooked meals and finding the best bargains.

**Lorna Goodwin** for showing me how females work in a male dominated area

**Jez Noond** for introducing me to 'ART' - I think it was art

**Kate Strange** for introducing me to vegetarian cuisine and walking

**Ashley Tucker** (now Dr) and **Alison Clarke** for sharing their flat with this antipodean and educating me in 'car-bootie' etiquette.

**Also** the guy at the IRISH whose comments provided me with a reality check:

**"Its good to see a DAD come out with his kids"**

I thank my family for the encouragement and also in allowing me to leave the country when a certain beach house required painting, also apologies to the **Rule** family for the football (Aussie Rules - Andy) matches missed.

Thanks to my very good friend **Ruth Meechin-Fowle** and my beautiful daughter **Alexis**. Their support, encouragement and allowing me to travel to the UK for extended periods without taking a teenage daughter, who so desperately wanted to accompany me so she could see historical England and not because she would be away from school ....

Last but not least the person who got this project up and running and who provided me with an ear for listening, a brain for advice and wisdom, and friendship for support. My friend (and buddy) and local supervisor **Emeritus Professor Odwyn (2-4-1) Jones** whose enthusiasm, dedication and energy puts most to shame.

**"THANKS ODWYN"**

# Table of Contents

<b>1</b>	<b>INTRODUCTION.....</b>	<b>I</b>
1.1	BACKGROUND .....	23
1.2	ACCIDENT RECONSTRUCTION.....	24
1.3	CG&V AS A RECONSTRUCTION TOOL.....	25
1.4	CG&V AS A TRAINING TOOL.....	26
1.5	STATEMENT OF RESEARCH PROBLEM.....	28
1.6	RESEARCH AIMS .....	29
1.7	SCOPE OF WORK.....	29
1.8	RESEARCH METHODOLOGY .....	29
1.9	THESIS OVERVIEW.....	30
1.10	TERMS AND DEFINITIONS.....	33
<b>2</b>	<b>MINERALS AND ENERGY REVIEW .....</b>	<b>35</b>
2.1	INTRODUCTION.....	35
2.2	REPORTS AND INQUIRIES THAT INFLUENCED THE MINERALS AND ENERGY INDUSTRY.....	35
2.3	MINING SECTOR DISASTERS.....	37
2.4	ENERGY SECTOR DISASTERS.....	42
2.4.1	Petroleum.....	43
2.4.2	Gas .....	45
2.4.3	Nuclear.....	47
2.5	AUSTRALIAN MINERALS AND ENERGY INDUSTRY HISTORY .....	49
2.6	WA'S MINERALS AND ENERGY INDUSTRY HISTORY .....	51
2.7	WA'S MINING ACTS AND REGULATIONS.....	54
2.7.1	Achieving the objectives of the legislation.....	55
2.7.2	Reporting accidents.....	56
2.8	WA'S PETROLEUM ACTS AND REGULATIONS.....	56
2.8.1	Achieving the objectives of the legislation.....	57
2.8.2	Reporting accidents.....	57
2.8.3	Reporting spillages.....	58

2.9	TRAINING IN THE MINERALS AND ENERGY SECTOR .....	58
2.9.1	Traditional methods.....	59
2.9.2	Training as required by the WA mining regulations.....	62
2.10	CONCLUSION .....	63
<b>3</b>	<b>COMPUTER GRAPHICS AND VISUALISATION.....</b>	<b>64</b>
3.1	INTRODUCTION.....	64
3.2	HISTORY OF VISUALISATION.....	64
3.2.1	Art .....	64
3.2.2	Writing .....	66
3.2.3	Printing.....	68
3.2.4	Photography .....	70
3.2.5	Television .....	72
3.3	HISTORY OF COMPUTER GRAPHICS.....	76
3.4	COMPUTER GRAPHICS AND VISUALISATION.....	78
3.4.1	Entertainment .....	79
3.4.2	Industry .....	82
3.5	VIRTUAL ENVIRONMENTS.....	88
3.5.1	Immersive virtual environments .....	89
3.5.2	Non-immersive virtual environments .....	90
3.6	CONCLUSION .....	91
<b>4</b>	<b>COMPUTER GRAPHICS AND VISUALISATION FOR COURTROOMS .....</b>	<b>93</b>
4.1	INTRODUCTION.....	93
4.2	COMPUTER GRAPHICS AND VISUALISATION FOR UNDERSTANDING.....	93
4.3	LEGAL USES OF CG&V AND RELEVANT ISSUES .....	96
4.3.1	Definitions.....	97
4.3.2	Admissibility .....	99
4.3.3	Admissibility in Western Australia courts.....	100
4.3.4	Admissibility in other Australian courts .....	102
4.3.5	Admissibility overseas .....	105

4.3.6	When to use.....	107
4.4	CONCLUSION .....	108
<b>5</b>	<b>TECHNOLOGY IN THE MINERALS AND ENERGY SECTORS .....</b>	<b>110</b>
5.1	INTRODUCTION.....	110
5.1.1	For investigation.....	110
5.1.2	For planning .....	112
5.1.3	For training.....	116
5.1.4	For research.....	124
5.2	CONCLUSION .....	126
<b>6</b>	<b>CASE STUDY 1 – UNDERGROUND FIRE DISASTER .....</b>	<b>127</b>
6.1	INTRODUCTION.....	127
6.2	UNDERGROUND FIRE REPORTS AND INFORMATION.....	129
6.2.1	Significant Incident Reports (SIRs).....	129
6.2.2	Incidents Reports (Irs).....	130
6.2.3	Safety bulletin .....	130
6.3	UNDERGROUND FIRE CASE STUDY.....	131
6.3.1	Incident description.....	133
6.4	RECONSTRUCTION OF EVENTS.....	136
6.4.1	Mine details .....	136
6.4.2	Vehicle details .....	141
6.4.3	Assembling the events.....	143
6.4.4	Showing the completed reconstruction.....	146
6.4.5	Outcome of reconstruction.....	147
6.5	TRAINING APPLICATION.....	148
6.5.1	The design and setup.....	148
6.5.2	Outcome of application.....	150
6.6	CONCLUSION .....	151
<b>7</b>	<b>CASE STUDY 2 – SURFACE MINE ACCIDENT .....</b>	<b>152</b>
7.1	INTRODUCTION.....	152



7.2	OVER THE EDGE .....	153
7.2.1	Significant Incident Reports (SIRs).....	156
7.2.2	Incidents Reports (IRs).....	157
7.2.3	Safety bulletin .....	158
7.3	OVER THE EDGE CASE STUDY.....	159
7.3.1	Accident scenario .....	162
7.4	RECONSTRUCTION OF EVENTS.....	162
7.4.1	Mine details .....	163
7.4.2	Vehicle details .....	164
7.4.3	The reconstruction.....	165
7.5	TRAINING APPLICATION.....	167
7.6	OUTCOME OF RECONSTRUCTION AND TRAINING APPLICATION.....	170
7.7	CONCLUSION .....	170
<b>8</b>	<b>CASE STUDY 3 - EXPLORATION DRILLING.....</b>	<b>171</b>
8.1	INTRODUCTION.....	171
8.2	THE CASE STUDY .....	173
8.2.1	Case Scenario .....	173
8.3	RECONSTRUCTION OF EVENTS.....	174
8.3.1	What is to be presented .....	174
8.3.2	Down The-Hole hammer .....	174
8.3.3	Reverse circulation drilling .....	177
8.3.4	Geological influences .....	179
8.3.5	Separation cyclone.....	180
8.3.6	Vehicle details .....	182
8.3.7	Assembling the events.....	183
8.3.8	Showing the completed reconstruction.....	186
8.3.9	Outcome of reconstruction.....	188
8.4	TRAINING APPLICATION.....	189
8.4.1	Development of the application.....	189
8.4.2	Outcome of application.....	190

8.5	CONCLUSION .....	190
<b>9</b>	<b>CASE STUDY 4 – OFFSHORE OIL SPILLAGE.....</b>	<b>192</b>
9.1	INTRODUCTION.....	192
9.2	SPILLAGE CASE STUDY.....	195
9.2.1	Incident Description.....	196
9.3	RECONSTRUCTION OF EVENTS.....	198
9.3.1	Valve and hose details .....	198
9.3.2	Tanker details .....	199
9.3.3	Storyboarding the events.....	199
9.3.4	Assembling the events.....	202
9.3.5	Calculating the zone of probability .....	205
9.3.6	Outcome of the reconstruction.....	206
9.4	TRAINING APPLICATION.....	207
9.4.1	The design and setup.....	207
9.5	CONCLUSION .....	208
<b>10</b>	<b>FEEDBACK AND ASSESSMENT OF CASE STUDIES .....</b>	<b>210</b>
10.1	INTRODUCTION.....	210
10.2	PREVIOUS WORK.....	212
10.2.1	Example 1 – effectiveness of low cost VE systems .....	212
10.2.2	Example 2 - effectiveness of training simulations .....	213
10.2.3	Example 3 - effectiveness of CBT and simulations .....	215
10.2.4	Example 4 - effectiveness of simulations .....	215
10.2.5	Analysis of examples .....	217
10.3	METHOD OF EVALUATION.....	218
10.3.1	The questionnaire .....	218
10.3.2	The presentation .....	219
10.3.3	Design type.....	220
10.4	RESULTS.....	220
10.4.1	Demographics of attendees.....	220

10.4.2	Recognition and comprehension of visual material - Q1-3 .....	223
10.4.3	General views of visual material - Q4-5 .....	224
10.4.4	Perception of the visual material - Q6-7 .....	225
10.4.5	Attitude towards the use of the visuals material - Q8-9 .....	226
10.4.6	Understanding presented visual material - Q10-11 .....	227
10.5	CONCLUSION .....	229
<b>11</b>	<b>CONCLUSIONS AND RECOMMENDATIONS .....</b>	<b>231</b>
11.1	INTRODUCTION.....	231
11.2	OVERVIEW OF THESIS .....	231
11.3	SUMMARY OF FINDING.....	232
11.3.1	Current CG&V technology.....	232
11.3.2	Hypothetical case studies.....	233
11.3.3	Real case studies.....	233
11.3.4	Developing the reconstructions.....	235
11.3.5	Developing the training applications .....	235
11.3.6	Evaluation and assessment .....	236
11.4	RECOMMENDATIONS.....	236
11.5	FURTHER WORK.....	237
11.6	CONCLUDING REMARKS.....	239
<b>FURTHER MATERIAL PRODUCED .....</b>		<b>ERROR! BOOKMARK NOT DEFINED.</b>
CONFERENCE PUBLICATIONS.....		<b>ERROR! BOOKMARK NOT DEFINED.</b>
JOURNAL PUBLICATIONS.....		<b>ERROR! BOOKMARK NOT DEFINED.</b>
CONFERENCE ATTENDANCE.....		<b>ERROR! BOOKMARK NOT DEFINED.</b>
<b>REFERENCES .....</b>		<b>ERROR! BOOKMARK NOT DEFINED.</b>
<b>APPENDICES .....</b>		<b>ERROR! BOOKMARK NOT DEFINED.</b>
APPENDIX NO. 1:- NEW HARTLEY DISASTER 16 <sup>TH</sup> JANUARY 1862 .....		<b>ERROR! BOOKMARK NOT DEFINED.</b>
APPENDIX NO. 2:- THE MAYPOLE COLLIERY DISASTER 1908 .....		<b>ERROR! BOOKMARK NOT DEFINED.</b>

APPENDIX NO. 3:- LONGFORD ROYAL COMMISSION – LETTER TO ESTABLISH.....**ERROR!**  
**BOOKMARK NOT DEFINED.**

APPENDIX NO. 4:- TIMELINE OF AUSTRALIAN MINERAL AND ENERGY DISCOVERIES. ....**ERROR!**  
**BOOKMARK NOT DEFINED.**

APPENDIX NO. 5:- TIMELINE OF AUSTRALIAN MINE DEATHS (1882-1991).. **ERROR! BOOKMARK NOT DEFINED.**

APPENDIX NO. 6:- EXTRACTS OF MSI 1994 – PART 7 SECT 75-79 ..... **ERROR! BOOKMARK NOT DEFINED.**

APPENDIX NO. 4:- WA AND AUSTRALIAN PETROLEUM ACT AND REGULATIONS.....**ERROR!**  
**BOOKMARK NOT DEFINED.**

APPENDIX NO. 8:- MINESAFE – MOD MAGAZINE.....**ERROR! BOOKMARK NOT DEFINED.**

APPENDIX NO. 9:- BRAMBLES VS OTHERS, SUPREME COURT OF W.A., 1994.....**ERROR!**  
**BOOKMARK NOT DEFINED.**

APPENDIX NO. 10:- ADMINISTRATIVE APPEALS (PLANNING), VICTORIA, 1994.....**ERROR!**  
**BOOKMARK NOT DEFINED.**

APPENDIX NO. 11:- QUEEN VS CHALLONER, SUPREME COURT OF VICTORIA, 1996 .....**ERROR!**  
**BOOKMARK NOT DEFINED.**

APPENDIX NO. 12:- TOOMEY VS SCOLARO, SUPREME COURT OF VICTORIA, 1997.....**ERROR!**  
**BOOKMARK NOT DEFINED.**

APPENDIX NO. 13:- LONGFORD ROYAL COMMISSION, VICTORIA, 1998....**ERROR! BOOKMARK NOT DEFINED.**

APPENDIX NO. 14:- ROLLING ROCKS BROCHURE.....**ERROR! BOOKMARK NOT DEFINED.**

APPENDIX NO. 15:- LETTER FROM MR KEN STEELE.....**ERROR! BOOKMARK NOT DEFINED.**

APPENDIX NO. 16:- UDR DRILL RIG INFORMATION.....**ERROR! BOOKMARK NOT DEFINED.**

APPENDIX NO. 17:- INTRODUCTION TO THE SAFETY CASE CONCEPT .. **ERROR! BOOKMARK NOT DEFINED.**

APPENDIX NO. 18:- APPEA REPORTING DEFINITIONS.....**ERROR! BOOKMARK NOT DEFINED.**

APPENDIX NO. 19:- 2D VALVE PLAN LAYOUT .....**ERROR! BOOKMARK NOT DEFINED.**

APPENDIX NO. 20:- AIMS SOLUTIONS LANDFILL INSPECTION BROCHURE.. **ERROR! BOOKMARK NOT DEFINED.**

APPENDIX NO. 21:- QUESTIONNAIRE.....**ERROR! BOOKMARK NOT DEFINED.**

APPENDIX NO. 22:- INNOVATION FESTIVAL BROCHURE .....**ERROR! BOOKMARK NOT DEFINED.**

## List of Figures

Figure 1-1: Deliberately crashed vehicle ready for examination.....	26
Figure 2-1: Pit Bottom, 1835 – The Penny Magazine No.125 .....	38
Figure 2-2: Sketch showing crowds waiting for news, Hartley Colliery 1862 .....	39
Figure 2-3: The Burning Maypole Colliery - 29/8/1908, (Winstanley, 2001) .....	40
Figure 2-4: WA Newspaper 28 June 2000 .....	41
Figure 2-5: IXTOC oil spill .....	43
Figure 2-6: Piper-Alpha platform (BBC-NOS, 1998).....	44
Figure 2-7: Piper-Alpha first rescue craft (TU Delft, 1999).....	44
Figure 2-8: First major release, Longford R.C. ....	45
Figure 2-9: Second and Third major release, Longford R.C. ....	46
Figure 2-10: FE model of GP905 .....	46
Figure 2-11: Three Mile Island reactor.....	47
Figure 2-12: Cloud dispersement diagram .....	48
Figure 2-13: Aboriginal art work (Minefact, 2000).....	49
Figure 2-14: Searching for gold (anon, 1892). ....	52
Figure 2-15: Fimiston alias the <i>Superpit</i> .....	53
Figure 2-16: Map of WA Minerals & Energy Areas (Courtesy DoIR).....	54
Figure 2-17: Commonwealth & State Petroleum Acts boundaries .....	57
Figure 2-18: DoIR safety notices.....	60
Figure 2-19: Safety videos .....	61

Figure 2-20: CBT applications .....	61
Figure 3-1: The rainbow serpent .....	65
Figure 3-2: Early cylinder seal depicting beer production .....	67
Figure 3-3: A picture and writing .....	67
Figure 3-4: A page from the Guttenburg bible .....	69
Figure 3-5: Cover of Penny Magazine Feb 28, 1835 .....	70
Figure 3-6: Anaglyph process .....	71
Figure 3-7: Nipkow's scanning disk .....	73
Figure 3-8: Baird's mechanical television diagram .....	73
Figure 3-9: Zworkin demonstrating TV in 1929 .....	74
Figure 3-10: Iconoscope diagram .....	75
Figure 3-11: High definition and standard TV ratios .....	75
Figure 3-12: Sutherland at the console - Sketchpad project MIT 1963 .....	77
Figure 3-13: TRON the movie released .....	80
Figure 3-14: Kyoko Date front cover of magazine .....	81
Figure 3-15: Final Fantasy scene .....	81
Figure 3-16: Final Fantasy characters .....	82
Figure 3-17: GIS is layering information .....	83
Figure 3-18: Stress Analysis Model .....	85
Figure 3-19: Heave plates .....	86
Figure 3-20: Calculated pressure contours around a submerged heave plate .....	87

Figure 3-21: Image from a commercial flight training application.....	87
Figure 3-22: Virtual fantasy (Summerville, 1993).....	88
Figure 3-23: Researchers viewing 3D brain .....	90
Figure 3-24: Non immersive laparoscopic training .....	91
Figure 4-1: Scene from Marotta case (Courtesy M Annear) .....	101
Figure 4-2: Layout of the ICSRS scene showing hotspots and evidence found..	104
Figure 5-1: Reclaimer after the collapse (DME, 1996) .....	110
Figure 5-2: Model in its initial state .....	111
Figure 5-3: Model in the collapsed state.....	111
Figure 5-4: Mine planning (Surpac, 2001).....	113
Figure 5-5: Mine design (Fractal Graphics, 2001) .....	114
Figure 5-6: Diesel fumes upcasting a ventilation shaft .....	114
Figure 5-7: A main mine fan.....	115
Figure 5-8: VnetPC2000 screen capture of a mine ventilation system .....	115
Figure 5-9: VnetPC 2000 screen capture of airflow quantities and direction .....	116
Figure 5-10: 3-Point contact (courtesy A Bruz and M Annear) .....	117
Figure 5-11: Inside the haul truck simulator cabin .....	118
Figure 5-12: Screen capture of simulated haul road system.....	119
Figure 5-13: SAFE-VR - Video file activated.....	121
Figure 5-14: SAFE-VR, multimedia selection .....	122
Figure 5-15: VRMST – VR mine plan.....	123



Figure 5-16: VRMST – before going underground .....	123
Figure 5-17: VRMST – underground environment .....	124
Figure 5-18: Virtual Mine.....	125
Figure 6-1: U/G mobile equipment fires .....	127
Figure 6-2: An underground truck fire .....	129
Figure 6-3: Fighting an underground fire .....	131
Figure 6-4: Truck on fire (courtesy DoIR) .....	132
Figure 6-5: Sections of the script.....	136
Figure 6-6: 3D representation of the mine.....	137
Figure 6-7: Measuring XYZ from 2D plan.....	138
Figure 6-8: Spreadsheet of pegs and measured co-ordinates.....	139
Figure 6-9: Lofting .....	140
Figure 6-10: Screen capture showing declines and ventilation shafts .....	140
Figure 6-11: Rendered sectional mine model.....	141
Figure 6-12: Haul truck 2D drawing with measurements .....	142
Figure 6-13: Wireframe of haul truck.....	142
Figure 6-14: Haul truck on fire in decline .....	143
Figure 6-15: Overview of mine and sectional cut away.....	143
Figure 6-16: Cabling and Refuge chamber.....	144
Figure 6-17: Evacuation route .....	144
Figure 6-18: Location of incident .....	145

Figure 6-19: Loss of communications and smoke direction.....	145
Figure 6-20: Men safe in refuge chamber.....	145
Figure 6-21: Reversing fan direction.....	146
Figure 6-22: Extract from Minesafe2000 brochure .....	146
Figure 6-23: The players and task .....	148
Figure 6-24: Overview to the mine.....	149
Figure 6-25: Ventilation system described .....	149
Figure 6-26: Additional information .....	149
Figure 6-27: Final training slides.....	150
Figure 7-1: Big truck present big problems .....	152
Figure 7-2: Incidents reported and number of mobile plant incidents.....	153
Figure 7-3: Explosives truck over the edge (DME, 1991).....	154
Figure 7-4: Nugget poster .....	154
Figure 7-5: Minesafe magazine Dec 1994 .....	155
Figure 7-6: Montage of overturned trucks (courtesy DoIR).....	156
Figure 7-7: Minesafe magazine Dec 1997 .....	160
Figure 7-8: Prosecutions and Legal Proceeding Course .....	161
Figure 7-9: Site plane of where accident occurred .....	164
Figure 7-10: 3D truck model (AIMS Research) .....	164
Figure 7-11: Night work .....	165
Figure 7-12: Pre- inspection of vehicle and missing seatbelt .....	165

Figure 7-13: Truck heading to stope and reversing ready to dump .....	166
Figure 7-14: Truck falling over edge .....	166
Figure 7-15: Final resting place of vehicle .....	167
Figure 7-16: Location and aerial view of mine .....	167
Figure 7-17: Screen captures of web-based application .....	168
Figure 7-18: Personal information screen.....	168
Figure 7-19: Navigation hotspots within the application .....	169
Figure 7-20: Inspector findings .....	169
Figure 8-1: SECOROC DTH Schematic .....	174
Figure 8-2: Wireframe 3D model .....	175
Figure 8-3: Types of drill bits (Halco, n.d. ).....	176
Figure 8-4: Rendered drill bit .....	176
Figure 8-5: Split view of rendered DTH.....	177
Figure 8-6: DTH Bit air and sample flow (Chugh et al, 1996).....	178
Figure 8-7: Airflow schematics (Chugh et al, 1996) .....	178
Figure 8-8: Geological influences (Chugh et al, 1996) .....	179
Figure 8-9: Wireframe model of geological influences.....	180
Figure 8-10: Cyclone .....	181
Figure 8-11: Model of cyclone .....	181
Figure 8-12: 3D model of cyclone .....	182
Figure 8-13: Exploration drill - Courtesy UDR.....	182

Figure 8-14: Overview of environment .....	184
Figure 8-15: Drill rig and sectional view of ground .....	185
Figure 8-16: Split DTH in ground .....	185
Figure 8-17: Sectionalised DTH.....	186
Figure 8-18: Airflow to cyclone .....	186
Figure 9-1: Total reportable injuries by jurisdiction in 2000 .....	193
Figure 9-2: Medical treatment and alternative duties injury frequency rates 1996- 2000.....	194
Figure 9-3: Industry fatality frequency rate 1995-2000 (APPEA, 2000) .....	194
Figure 9-4: Location map .....	196
Figure 9-5: Hang-off-chain.....	197
Figure 9-6: Purge valve plan.....	197
Figure 9-7: Subsea hose diagram/plan.....	198
Figure 9-8: Damaged valves .....	199
Figure 9-9: Tender vessel and tanker.....	199
Figure 9-10: Storyboard for setting the scene .....	201
Figure 9-11: Screen capture (during development) .....	202
Figure 9-12: Screen shots of hose & chain entanglement .....	203
Figure 9-13: Screen shots - tender boat approaching tanker .....	203
Figure 9-14: Screen shots - tanker crane lifting hose .....	204
Figure 9-15: Screen shots of the zone of probability.....	205

Figure 9-16: Zone of probability calculated .....	206
Figure 10-1: Screen shoot of landfill application.....	212
Figure 10-2: I-Sim PatrolSim™ driving simulator .....	214
Figure 10-3: Presentation taking place .....	219
Figure 10-4: Employment area .....	220
Figure 10-5: Working environment .....	221
Figure 10-6: Quailifications achieved by attendees.....	221
Figure 10-7: Computer access .....	222
Figure 10-8: Age .....	222
Figure 10-9: Question 1 – what was being described.....	223
Figure 10-10: Question 2 – additional information.....	223
Figure 10-11: Question 3 - percieved ideas .....	224
Figure 10-12: Question 4 - better understanding .....	224
Figure 10-13: Question 5 – understanding technical discussions .....	225
Figure 10-14: Question 6 – depict reality .....	225
Figure 10-15: Question 7 – a sense of reality .....	226
Figure 10-16: Question 8 – tool for explaining things .....	227
Figure 10-17: Question 9 – tool for demonstrating things .....	227
Figure 10-18: Question 10 – understand what was showing .....	228
Figure 10-19: Question 11 – provide additional information.....	228
Figure 10-20: Results of all 11 questions (Averaged out).....	229

## **Abbreviations**

The following abbreviations are used in this thesis:

CAD.....Computer Aided Design

CAM.....Computer Aided Manufacture

CBT.....Computer Based Training

CFD.....Computational Fluid Dynamics

CG.....Computer Graphics

CG&V.....Computer Graphics and Visualisation

CG&VG.....Computer Graphics and Visual Graphics

CG&VR.....Computer Graphics and Virtual Reality

DoIR.....Department of Industry and Resources (formerly MPR and DME)

DME.....Department of Minerals and Energy (see DoIR)

FEA.....Finite Element Analysis

GUI.....Graphical User Interface

LNG.....Liquefied Natural Gas

MSIA.....Mines Safety and Inspection Act

MSIR.....Mines Safety and Inspection Regulations

MOSHAB.....Mines Occupational Safety and Health Advisory Board of Western  
Australia

MOD.....Mining Operations Division

MPR.....Department of Minerals and Petroleum Resources (formerly DME  
see DoIR)

NIOSH.....National Institute for Occupational Safety and Health

NURBS.....Non-Uniform Rational B-Splines

OH&S.....Occupational Health and Safety

PC.....Personnel Computer

PD.....Petroleum Division

SME.....Subject Matter Expert

TAFE.....Technical and Further Education

UoN.....University of Nottingham

VE.....Virtual Environment

VR.....Virtual Reality

WA.....Western Australia





# 1 INTRODUCTION

## Background

The minerals and energy sector can rightly be classified as comprising an extremely hazardous working environment in which numerous situations exist for accidents and incidents involving personnel and equipment to occur. When an accident or incident does occur, as in any other industry, there are invariably serious ramifications. It is, therefore, important to obtain a clear understanding of the causes and factors involved in order to satisfy legal and investigative requirements, and to prevent similar incidents from occurring in the future.

It is not possible for a detailed investigation to be conducted into every accident or incident, which occurs. A Department of Industry and Resources' (DoIR) inspector may have to rely on company investigations and/or system reports to provide details of minor accidents and some types of serious accidents and reportable incidents. Having said this, these reports are carefully scrutinised and any unusual circumstances will be noted for further investigation and/or subsequent action on the next scheduled DoIR site inspection.

Certain types of occurrences require immediate detailed investigation and inquiry by a DoIR Inspector such as:

?? Any fatal accident.

?? Any accident or incident involving detonation of explosive.

?? Any fire necessitating the evacuation of personnel or involving smoke inhalation by personnel.

While the information gathered during such an accident investigation serves the specific purpose of trying to ascertain the relevant facts, it invariably takes the form of text and abstracts (scientific and industry related), and two-dimensional (2D) plans and sections. This information and data cannot easily be interpreted nor understood by all interested parties. This shortcoming can be addressed by depicting the data in a more intuitive and meaningful manner using computer graphics and visualisation (CG&V). Through a range of processes this can lead to

the development of applications from accident reconstructions to training applications.

Large organisations are continually looking for ways to improve their performance, particularly safety performance since this may help to reduce their accident statistics and insurance premiums. CG&V provides a very real way in which complex ideas and information can be transmitted to a work force. The capacity of human beings to remember information from a three-dimensional (3D) based computer world is far greater than their ability to translate information from a printed page into a real 3D environment. This understanding enhancement has been extensively discussed by a number of authors (cf. Rheingold, 1991 and Krueger, 1991).

The ability of a computer to create synthetic copies of the real world, whether in computer animations or virtual reality, provides a number of opportunities to enhance current training methods. Allowing users to learn within computer-generated environments provides the opportunity for them to make mistakes and suffer the consequences without necessarily putting themselves at risk.

The computer based nature of the simulations often provide much needed novelty value to the training process, resulting in users paying more attention and learning more efficiently. However great care has to be taken to ensure that both the visual nature and simulation dynamics accurately reflect the real world to prevent the simulation losing credibility to cynical trainees (Schofield et al, 2000a).

## **Accident Reconstruction**

Accident reconstruction, recreation or re-enactment is a technique increasingly being applied to facilitate better understanding and interpretation of the factors and sequence of events leading to incidents and accidents in a variety of industries. The objective of an accident reconstruction is to simulate the sequence of events and actions leading up to and involved in a particular incident or accident.

In modern society, animations form a part of everyday presentations for sales, news, entertainment and training. The general public is used to viewing descriptions of incidents via animations from the news media. It would seem a

natural progression to incorporate such a flexible medium into the courtroom environment (Doyle, 1999).

CG&V can be used in a variety of circumstances for accident scene reconstruction, eyewitness testimony verification, data visualisation and training a workforce after an accident or incident. The ability to visualise complex and dynamic situations involving people, machinery and an environment, is a potential advantage of the application of this technology (Schofield et al, 2000b).

### **CG&V as a Reconstruction Tool**

In the UK, a series of experiments were conducted at the Crash Investigation and Training Unit (CITU), West Midlands Police Service. Three separate groups were asked to memorise a series of accident information. One group were shown textual descriptions, a second group were shown images and a third group were shown both the text and the images. As was expected the group who saw only text performed the worst with a number of errors. The group who saw the images made very few mistakes and the group shown both text and images performed the best (Doyle 1999).

PC Doyle goes on to explain the advantage of using computer-generated evidence succinctly in this particular quote from CAD User Magazine (1997):

*In many ways [CG animation] is a more powerful tool than the video footage we have access to on the all-too-rare occasions when it exists. Once we have a reasonable sequence of events we can play around with the camera positions to our heart's content. We can even place the camera where an eyewitness says he was standing – complete with darkness and fog effects – and judge whether his story fits with our reconstruction. At the end of the day a jury will be more comfortable with an animated sequence than it will be with a whole load of facts and figures from someone like me.*

A study entitled 'The Weiss-McGrath Report' found that after 72 hours, participants retained 10 percent of verbally presented information, while those who received the information visually retained 20 percent. But those who both heard and saw (visual and verbal presentation) retained 65 percent of the information (Berkoff, 1994).

In another study conducted in a research courtroom called *Limited Courtroom 21*, researchers found that jurors, regardless of age, prefer visually presented material. *Limited Courtroom 21* is a research project courtroom that is an international demonstration and experimental centre utilising commercially available state of the art technology located at William and Mary School of Law (Kuehn, 1999).

The minerals and energy sector can also benefit greatly from the implementation of computer graphics and visualisation (CG&V) as a forensic reconstruction and an investigative tool. It is unlikely for example, that a physical reconstruction of an underground rockfall can be physically reconstructed due to, costs, safety and availability of a similar geological domain. However physical reconstructions of motor vehicle accidents similar to the one shown in figure 1-1 where a vehicle was deliberately crashed in a controlled environment allows results to be taken for future use.



**Figure 1-1: Deliberately crashed vehicle ready for examination**

If all the forensic and investigative information is available then the reconstruction can be developed and presented to an inquiry. If not then ‘what if’ scenarios could be developed to address multiple possible scenarios.

### **CG&V as a Training Tool**

The proper training of employees to make them more productive should be a major ingredient in the strategy of any minerals company aspiring to establish and/or maintain its position as a world-class competitor.

Of particular note is the need to ensure that, not only are the safe working standards of the operation *communicated* during the induction process, but also that some positive check is carried out to ensure that the message presented has *actually been understood* by the employees receiving it (Torlach, 1998). Over the past few years, companies and governments have started to accept Computer Based Training (CBT) as a viable and valuable tool. Multi-media training provides dynamic graphics, sound and an interactive capability. Studies show that multi-media training often result in much greater retention rates than is the case with other media delivery systems, because students tend to become much more involved with content than with manuals or other text-based training (Casanova, 1998).

More often than not, the greatest barrier to offering reliable training opportunities to minerals employees are time and distance. Mining companies can't afford to have key employees tied-up in classrooms for days at a time. If programs such as these remove logistics barriers, employees will move on to greater learning opportunities with greater speed, and employers will reap the residual benefits. In today's world of information technology, one needs to take advantage of every training advantage available (Schofield et al, 2000).

As Virtual Reality (VR) applications have grown in other industries there have been a number of studies of the cost effectiveness of these applications. Although there is little hard evidence within the mining industry there is sufficient indication that similar gains are possible in this sector. In the UK the Department of Trade and Industry (DTI) produced a report in 1998 summarising the UK experience of VR across a broad range of industries. The report summarised the results of a survey of 131 companies who were using VR and provided clear evidence of the benefits that can be achieved (Holland et al, 2000).

Key advantages included:

?? Improved communications (61 percent).

?? Better decision making (58 percent).

?? Fewer mistakes (54 percent ).

?? Improved quality (52 percent).

?? Greater efficiency (48 percent).

?? Greater competitiveness (46 percent).

Increasingly the use of CG&V as a training tool is providing the most effective training especially where hazardous environments are involved or where expensive equipment is being used. The traditional chalk and talk methods are not being replaced but enhanced, as there is still a requirement for human interaction even if it is as simple as informing the user of their mistakes or perhaps answering questions from the user who knows of another way of doing the task at hand.

## **Statement of Research Problem**

*It is important to identify the research question(s) you are addressing and to thereafter develop your 'hypothesis' or 'hypotheses' in an attempt to answer the question or questions (Jones, 2001).*

It is hypothesised that computer visualisation is a useful investigative and educational tool for industry personnel and the legal fraternity in examining the events leading up to serious incidents and/or accidents. This powerful mechanism in the reconstruction and analysis of events whereby animations are viewed and virtual worlds interactively navigated can be extremely valuable in:

?? Demonstrating to investigators the most likely sequence of events leading to the incident/accident in question. The use of such animated 3D models could lead to an increase in, and faster, out-of-court settlements as well as reducing court-time due to the legal representatives having a much clearer and realistic understanding of the issues involved.

?? Educating the legal fraternity of the situation prevailing at the work-face and/or surrounding the incident/accident in question. This can be particularly useful when the work situation(s) and practice(s) in the minerals and energy industry are difficult to explain to such persons as Judges, Coroners, and legal officers such as Barristers and Solicitors.

?? Developing training material for a company or industry groups with the intention of demonstrating inappropriate work practices and/or unexpected hazards which can lead to serious incidents/accidents

The research questions that are addressed in this thesis are:

?? What are the merits and level of acceptance associated with the use of computer visualisation techniques for the reconstruction of incidents/accidents?

?? What are the merits and level of acceptance associated with the use of computer visualisation techniques for training applications developed from the reconstruction of incidents/accidents?

## **Research Aims**

The main research aims are to:

?? identify what aspects of computer visualisation technologies are suitable for accident reconstruction and training applications;

?? identify suitable incidents/accidents to be used as case studies and gather relevant data;

?? develop visualisations of accident reconstruction case studies using relevant aspects of computer graphics technology;

?? develop appropriate computer visualisations for training using reconstructed case studies; and

?? identify features of computer visualisation from the reconstruction and training applications that are of relevance to the Western Australian minerals and energy sectors.

## **Scope of Work**

The research work is limited to a study of these aspects of computer visualisation appropriate to accident reconstruction and training within the minerals and energy sector of Western Australia with emphasis being placed on making the information gathered during accident/incident investigations more readily accessible to all interested parties.

## **Research Methodology**

A literature study was conducted with a view to providing an overview of the development, definition and application of accident reconstruction. The literature

study also serves to identify relevant CG&V technologies appropriate to developing accident reconstruction based applications for the minerals and energy sector. Moreover, the literature study helped to define the boundaries of the research problem.

A number of case studies were selected to represent the variety of incident/accident occurrences in the minerals and energy industry. Reconstructions of these events were visualised using appropriate technology components and utilised in a manner appropriate to the individual case.

The success of these endeavours was assessed and is discussed on a case by case basis with regard to improving understanding and training potential, as appropriate. Success is also judged by feedback from the relevant industry groups, public appraisals and from the outcome of any associated legal proceedings and actions. These are seen as a 'real' measures of effectiveness as the information collected has come from prospective user groups. It is hoped that this will represent a real benefit to those who will eventually use computer graphics and visualisation in their working environment (training) or be exposed to it as a necessity (Judicial /Coronial Inquiry).

## **Thesis Overview**

The contents of this thesis contains two halves. The first half (Chapters 1-5) is the literary study where the thesis presents historical and current information related to computer graphics and visualisation with references to the minerals and energy sector and Western Australia. The second half (Chapters 6-11) presents the case studies that were used to determine the outcome of the research which is also presented in this section.

### Chapter 1 – Introduction

This chapter presents and defines the scope of the project, the research problem and how it will be addressed.

### Chapter 2 – Mineral and Energy Review

This chapter references some influencing events, disasters, recording practices and subsequent inquiries within the minerals and energy sector. It also provides a brief historical overview of the minerals and energy sector in Australia. This chapter



also reviews the Western Australian minerals and energy sector including its history, the Acts and Regulations and training.

### Chapter 3 – Computer Graphics and Visualisation

This chapter presents a literature review of the role and application of computer graphics and visualisation from its early beginning to current day usage. It identifies the various forms of simulation and virtual environments and defines appropriate aspects of CG&V technology.

### Chapter 4 – Computer Graphics and Visualisation for Courtrooms

This chapter presents a review of the role of computer graphics and visualisation in courtrooms as evidence for assisting in explaining events and for the purpose of memory retention. This section also presents cases where CG&V has been used in Western Australia, other Australian states and overseas court rooms.

### Chapter 5 – Technology in the Minerals and Energy Sector

This chapter presents a review of current technology and the application of computer graphics and visualisation used by the minerals and energy sector. This section also looks at how technology is used in the minerals and energy sectors for investigation, planning, training and research.

### Chapter 6 - Case Study 1 - Underground Fire Disaster

This is a hypothetical accident reconstruction based on actual accident events. The accident scenario was developed by the Western Australian Department of Minerals and Petroleum Resources' Mining Operations Division along with the Western Australian Chamber of Minerals and Energy.

A vehicle catches fire underground with miners still working on underground levels beneath the fire. Due to the mine design and development, other incidents follow. This CG&V reconstruction and training application was a major focal event at the Minesafe 2000 International Conference in Perth Western Australia.

### Chapter 7 - Case Study 2 - Surface Mine Accident

This is also a hypothetical accident based on a number of actual events. The accident scenario was developed by the Western Australian Department of

Minerals and Petroleum Resources Mining Operations Division (MOD). They use the accident scenario (text based) information as part of their training to educate and demonstrate to MOD Inspectors how to collect and record information at a minesite that has just reported an accident.

The incident involves a haul truck falling over the edge of a stockpile while dumping its load. The scenario also examines other influencing events leading up to the accident. Parts of this CG&V reconstruction and training application were also shown at the Minesafe 2000 International Conference in Perth Western Australia.

### Chapter 8 - Case Study 3 - Exploration Drilling

This study is based on an actual incident. The reconstruction was used to assist an expert witness to describe to the Judges of the Western Australian Supreme Court of Appeal, how an exploration drill works. This case study is not a reconstruction that involves injury or damage but demonstrates to laypersons (in this case Judges) practices, principles and procedures in a working environment without having to leave the court room, costly shutdowns or using real equipment (which is often unavailable).

### Chapter 9 - Case Study 4 – Offshore Oil Spillage

This chapter presents an actual incident but due to out of court settlement conditions, names and identifying items have been changed.

This case involves a reconstruction of a subsea oil spillage and visualises what the DoIR's, Petroleum Division (PD) inspectors believe happened.

The reconstruction was not used in court nor shown to the defence due to the rapid settlement. The reconstruction was used to demonstrate to DoIR's PD inspectors and the Western Australian Department of Public Prosecutions (DPP) Crown Prosecutor that the scenario they were presenting was possible. The reconstruction was used as an investigative tool to examine a range of possible scenarios and see what scenarios could have led to the incident.

### Chapter 10 – Feedback and Assessment of Case Studies

This chapter reviews some of the literature on studies from researchers and industry personnel conducted on various uses of computer graphics and visualisation. This chapter also discusses the results of an evaluation of the work presented in this thesis based on a presentation of the case studies.

## Chapter 11 – Conclusions and Recommendations

This chapter provides conclusions and recommendations arising from this work and presents them for further consideration of researchers in the field of computer graphics and visualisation who are interested in its application to accident and incident investigation and training in the minerals and energy sector.

## **Terms and Definitions**

A number of terms and definitions are used in this thesis which are commonly used in their respective fields but may not be familiar to all readers. Therefore, the definitions of these terms are provided below:

### **Definitions**

*Computer Graphics* Graphics (images) implemented through the use of computers.

*Immersion* The sensation of being part of an environment be it real or virtual (Vince, 1995).

*NURBS* A mathematical representation that can accurately define any shape from a single line, circle, arc, or box to the most complex 3D free form organic surface or solid (Rhinoceros, 2000).

*Polygon* A shape bounded by straight edges, such as a hexagon (Vince,1995).

*Rendering* The process of converting a graphics object for on screen display (Psootka and Davison, 1996).

*Texture Mapping* The process of substituting detail stored within a texture (image) map onto an arbitrary surface (Vince, 1995).

*Virtual Environment* A 3D data set describing an environment based upon real-world or abstract objects and data (Vince, 1995).

<i>Virtual World</i>	A 3D model of an environment comprised of a set of objects or entities, which can be experienced as a virtual reality (Pulkka, 1997).
<i>Walk-Through</i>	The activity of moving through a virtual environment (Vince, 1995).
<i>Wire Frame</i>	A view of a 3D object where all the edges are drawn, producing a 'see through' wire like image (Vince, 1995).

## **2 MINERALS AND ENERGY REVIEW**

### **Introduction**

This chapter references some influencing events, disasters, recording practices and subsequent inquiries within the minerals and energy sector. It also provides a brief historical overview of the minerals and energy sector in Australia. This chapter also reviews the Western Australian minerals and energy sector including its history, the Acts and Regulations and training.

Current trends in global competition, continuing regulation of both the environmental and health and safety aspects of mining, the restructuring of all sectors of the industry, and the drive for incremental improvements of all performance aspects of operations have caused cultural changes in the way that mining is done. The cultural change is manifested in management, labour, government agencies (on federal and state levels), and academia (Grayson, 1998).

### **Reports and Inquiries that Influenced the Minerals and Energy Industry**

*Dead miners have always been the most powerful influence in securing passage of mining legislation. US Senator Jacob Javits of New York (Green, 1998).*

This section identifies some significant events that have influenced the minerals and energy sectors to improve their current position in respect to health and safety.

On the 3 December 1969 the revolutionary law called The Federal Coal Mine Health and Safety Act of 1969 came into being in the USA. This came about after 78 men died in a methane explosion at Consolidated Coal Company's No. 9 mine in Farmington West Virginia. Their bodies were never recovered. The mine was sealed several days after the explosion. This was not the only impetus for the new law. Public awareness also focussed on the ravages of coal workers' pneumoconiosis which had affected over 100,000 Americans (Green, 1998).

In 1972, the Robens' Committee inquiry into safety and health at work in the UK, led to the Health and Safety Act 1974 (HSWA). This was the biggest revolution in industrial legislation in British history. It created a framework for goal-setting regulations supported by Approved Codes of Practice (ACOPS) which enshrined the concept of self-regulation (Langdon, 1998).

The Cullen Report into the Piper Alpha disaster was released in 1989 by the Honourable Lord Cullen. The inquiry into this incident initiated the move away from prescriptive legislation, to a co-regulatory objective based approach to safety management in the upstream petroleum industry. This report had an international affect. The report was accepted in the UK and The Safety Case legislative regime was adopted in Australia, and became effective from 1 July 1992 for new production facilities, and from 1 July 1996 for existing production facilities and Mobile Offshore Drilling Units (MODUs).

The formation of the Leon Commission of Inquiry in 1994, into Safety and Health in the mining industry under the chairmanship of Judge Ramon Leon, identified a number of shortcomings in the South African Minerals Act, 1991-Act No.5 1991. This came about as a result of a number of horrific mine accidents involving multiple injuries and fatalities. As a result of the Inquiry these shortcomings were addressed by embarking upon a new tripartite process to draft the Mine Health and Safety Act which resulted in the promulgation of the Mine Health and Safety Act, 1996-Act No. 29 (Langdon, 1998).

It is apparent from the above that many countries are addressing outdated and in some cases non-existent legislation to ensure that workers are not exposed to unnecessary risk and unsafe practices. Many countries are adopting like recommendations, practices and procedures. For example, the Cullen Report has had a widespread impact on the petroleum industry worldwide.

In Western Australia due to the unprecedented number of mining sector fatalities, an inquiry was established by the Mines Occupational Safety and Health Advisory Board (MOSHAB) in September 1997 to investigate the issue. The taskforce presented its finding in the *Report on Fatalities in the Western Australian Mining Industry* and identified twenty-three recommendations, eight to be implemented by July 1998 and the remainder by December 1998.

Another report produced by MOSHAB entitled *Risk Taking Behaviour in the Western Australian Underground Mining Sector* was published in November 1998. The report found that the reasons given by employees and their supervisors for risk taking included production pressure, lack of skills, method of remuneration, saving time and effort and lack of awareness.

The various inquiries that happen around the world have implications to all industries not only to minerals and energy. One item that is continually mentioned in these reports is the lack of understanding of and training in safety procedures. Proper assessment needs to be continual to ensure workers are up to date with new techniques or procedures that a company or industry has installed.

The former West Australian State Mining Engineer Mr Jim Torlach (2001) sums this up in the following two sentences where he explains why we should listen to various reports:

*It is essential to continue to learn from experience of the past if serious mishaps are to be avoided.*

*It is all the better if the lessons are learned from the unfortunate previous experience of others, rather than repeating the process.*

## **Mining Sector Disasters**

During Victorian times there was great public interest in mining disasters and the Illustrated London News and The Graphic, were among other popular magazines of the time that dispatched artists to capture the scene at the stricken mine. The sketch was rushed back to the office and a skilled wood engraver would make the plate to produce the magazine illustration such as the one shown in figure 2-1 (Winstanley, 2001).

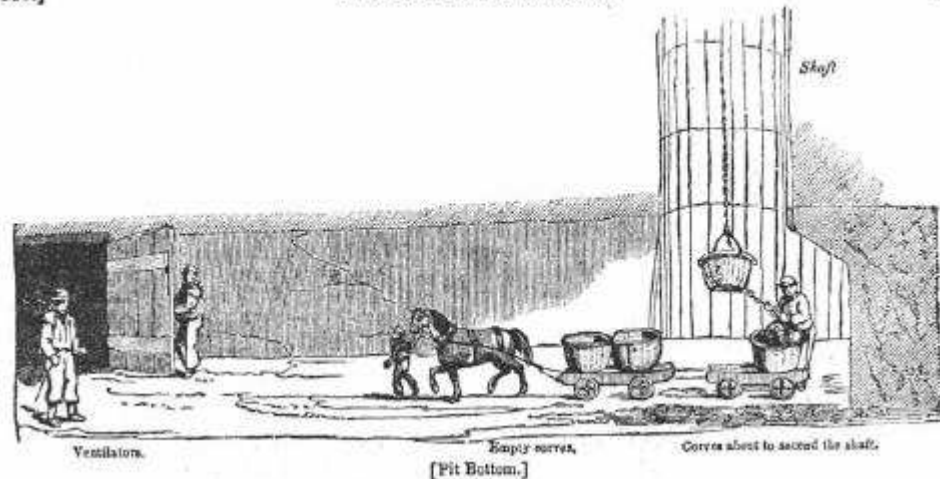

**Figure 2-1: Pit Bottom, 1835 – The Penny Magazine No.125**

The following is an extract of the reported fatal accident at the New Hartley Colliery in Northumberland, England where 204 men and boys lost their lives (Gardiner, 1983).

*At 10:30am on the 16<sup>th</sup> January 1862 the back shift at the New Hartley Colliery were in the process of relieving the shift which had started at 2.30am. As was the practice at that time one shift relieved the preceding one at the coalface. The first set of eight miners had started to ascend to the surface but of these men only three were to eventually see the light of day. As the cage was rising between the High Main and the Yard seams it suddenly came to a violent halt. Without any warning the beam of the giant pumping engine at the pit top suddenly fractured and twenty-one tons of cast iron hurtled down the shaft taking with it shaft supports, pipes and ventilation partition. The debris crashed on top of the cage severing two of its four support chains and flinging a number of miners to their deaths while the remainder miraculously clung to the damaged cage. A blockage 30 yards deep then formed at a vital part of the shaft allowing no means of escape for the trapped miners below.*

Figure 2-2 shows a sketch of the Hartley Colliery with people gathering to hear of news of the rescue. A detailed transcript and a sketch of the section of the mine that the accident occurred is available in Appendix 1.



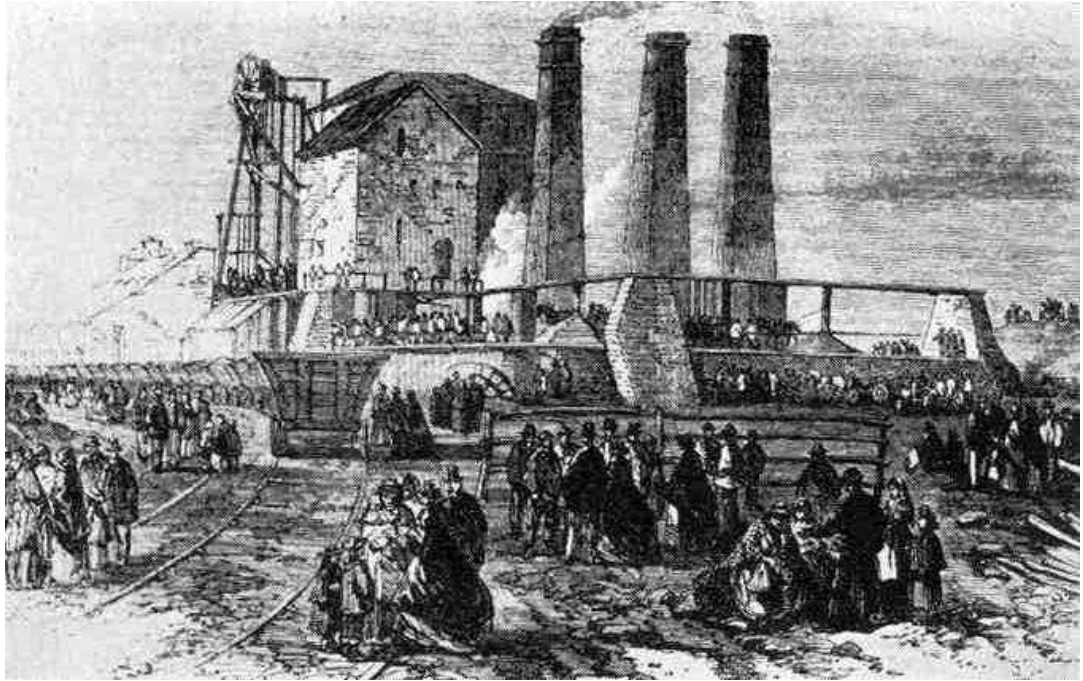

**Figure 2-2: Sketch showing crowds waiting for news, Hartley Colliery 1862**

Forty years on and drawings were still the best way to provide detailed information and explain the details of the disaster.

The following extract is from the transcript of the Coroners inquest of The Maypole Colliery Disaster of 1908. Part of the transcript is available in Appendix 2, (Maypole, 1998).

*Just after five in the evening on Tuesday, 18th August 1908, a deep rumble was heard within a radius of about a mile of the Maypole Colliery in Abram near Wigan. The thing dreaded by miners and their families had happened.....an explosion somewhere deep underground in the tunnels and roads of the pit.*

*A little over an hour before the explosion, at 4pm, the Maypole's day shift had returned to the surface, leaving the maintenance men, the firemen, the men who manned the pumps and the shot firers who would bring down the next day's coal in the miles of tunnels.*

*There were 78 men left underground, three working in the Seven Feet mine and seventy-five in the Wigan Four Feet. All the workers in the Wigan Four Feet lost their lives.*



It is not known if the drawing was used at the Coroners inquest or produced after all the evidence was collected. What is known is that it was constructed to explain the accident, as the title indicates – ‘The Accident Explained’.

With the introduction of modern printing, computers and animation software, the reconstruction of accidents and incidents can be relatively fast and effective, providing that the information is available. This is shown in a more recent example where illustrations were used as a way to explain how a mining accident happened.

On Wednesday 28 June 2000, The West Australian newspaper ran the following front-page article (Figure 2-4) to not only inform readers of the accident but to show by way of diagrams and photos, the magnitude of the accident.



Figure 2-4: WA Newspaper 28 June 2000

*At about 5.00pm on Monday 26 June 2000, a fill barricade ruptured and*

*allowed a considerable volume of mine fill, consisting of tailings in a slurry form, to enter the 12 and 13 levels of the mine and to flow to the bottom of the decline, which is the deepest part of the mine. Three employees died in the accident (EXIS, 2001).*

The only difference between all of the above examples is how the information was captured. Current technology uses photographs and computers to draw or generate the diagrams whereas in the early days the pictures were hand drawn and transferred to the print press and in some cases carved onto wood for printing. These processes had one thing in common; the information was to be used for public information whether it was for newspaper articles, teaching aids such as books and journals or later for litigation.

The use of graphics is prevalent in the examples presented, the images often dominate the story appearing on the front page of newspapers, as in the current case. The pictures allow the readers (and presenters) to provide information that is not readily available or easy to describe, for example the length of a tunnel or the depth of a mine. These concepts can be difficult to explain in words, but with visuals it is easier to show the magnitude of the problem. This therefore supports the use of computer graphics and visualisation as a tool to provide accident information to the public.

## **Energy Sector Disasters**

Bearing in mind the cost of establishing and maintaining these large and complex industrial sites, if a significant accident does occur, then company representatives and investigators will use every tool available to assist with the investigation. They will then use those tools to explain to the company, government, community and judicial sector what went wrong so that it will not happen again.

Accidents and incidents are also evident within the energy sector and sometimes the magnitude of the event is greater than that which occurs in the minerals sectors. The following examples demonstrate the validity of this statement.

## ?? *Petroleum*

### **1** Mexico

On June 3, 1979, the IXTOC-I exploratory well blew out in the Bay of Campeche off Ciudad del Carmen, Mexico (Figure 2-5). After three months of uncontrolled spillage, the oil had travelled 600 miles from the hole drilled. By the time the well was brought under control in late March 1980, an estimated 140 million gallons (3.5 million barrels) of oil had spilled into the bay. The IXTOC I is currently the second largest oil spill of all-time, eclipsed only by the deliberate release of oil, from many different sources, during the 1991 Gulf War (Taylor, 1999).

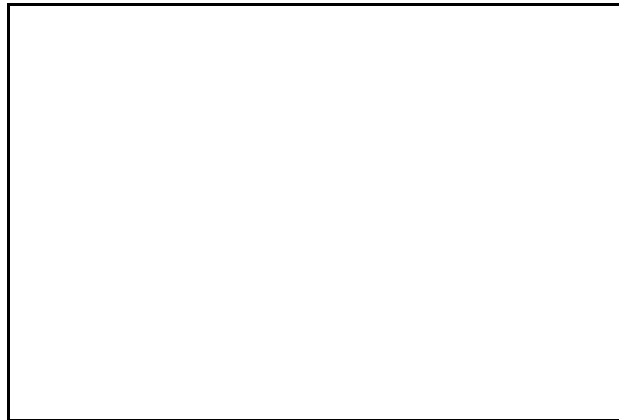

**Figure 2-5: IXTOC oil spill**

### **2** United Kingdom,

The Piper Alpha oil platform disaster, which occurred on the evening of 6 July 1988, was located in an oilfield in the North Sea about 110 miles north-east of Aberdeen. The platform was destroyed in an explosive conflagration (Figure 2-6). 167 persons lost their lives as a result of the accident either through being on board the platform or through being involved in rescue operations.



**Figure 2-6: Piper-Alpha platform (BBC-NOS, 1998)**

The disaster began with a routine maintenance procedure. A backup propane condensate pump in the processing area needed to have its pressure safety valve checked every 18 months. The valve was removed, leaving a hole in the pump. Because the workers could not get all the equipment they needed by 6:00 PM, they received permission to leave the rest of the work until the next day.

During the next work shift, a little before 10:00 PM, the primary condensate pump failed. The people in the control room, who were in charge of operating the platform, decided to start the backup pump, not knowing that it was under maintenance. Gas products escaped from the hole left by the valve with great force. At about 10:00, it ignited and exploded (Conway et al, 1999) (Figure 2-7).



**Figure 2-7: Piper-Alpha first rescue craft (TU Delft, 1999)**

A Public Inquiry began at on 19 January 1989 into the Piper Alpha disaster supervised by the Honourable Lord Cullen. The inquiry lasted for 125 days with a vast amount of information being presented. The information came in a variety of formats, including text, photographs and the use of CG&V in the shape of diagrams and computer generated models. These models were developed using such techniques as Computational Fluid Dynamics (CFD) and Finite Element Analysis (FEA) results.



## ?? **Gas**

The Liquefied Natural Gas (LNG) industry also has experienced major incidents.

### **3 Sydney, Australia 1998**

On Friday 25 September 1998, at about 12:26 in the afternoon, a vessel fractured, releasing hydrocarbon vapours and liquids. The fracture of the heat exchanger which began the series of explosions at the plant was preceded by a failure of the normal flow of hot oil through the equipment, which together with the continuing flow of very cold oil and condensate into the exchanger tank caused the temperature of the tank to fall well below freezing point (Mac, 1999).

Two employees were killed and eight others injured. Supplies of natural gas to domestic and industrial users were halted. The fire at the Longford plant raged for two days, and the supply of gas throughout Victoria did not resume until October 14, 1998 a total of 17days.

When employees finally restored the flow of hot oil into the tank, the extremes of temperature variation within the tank caused it to fracture, leading to an explosion of volatile gases, which subsequently ignited as shown in figures 2-8 and 2-9.



*Figure 7.2 The first major release, at 13:00:40*

**Figure 2-8: First major release, Longford R.C.**



Figure 7: The second major release, at 14:23:47

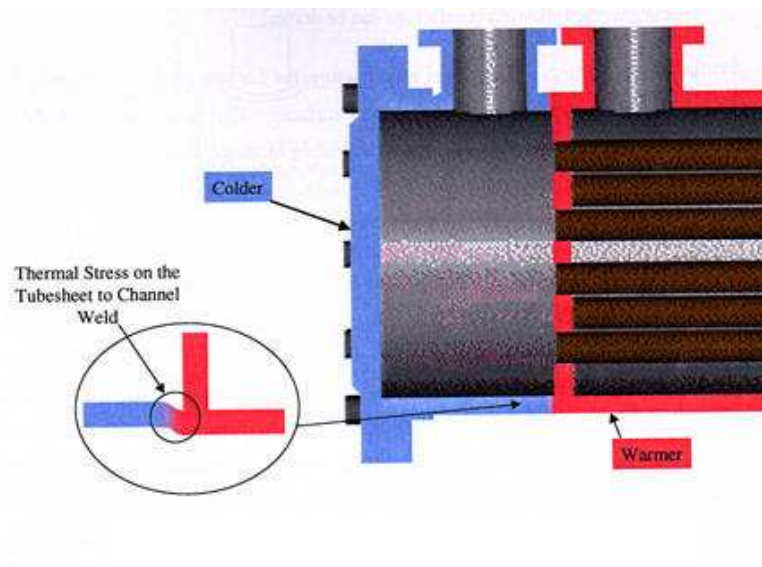

Figure 7A: The third major release, at 14:33:37

**Figure 2-9: Second and Third major release, Longford R.C.**

The explosions and fire at the Longford plant constituted one of the worst accidents in the history of Australian LNG industry, and a Royal Commission was established 20 October 1998 (Appendix 3) to report upon the causes of the explosion and fire which occurred at the gas production facility (Mac, 1999).

During the inquiry many people presented evidence, some of this evidence was presented in the form of 3D models and simulations. The following diagram (Figure 2-10) taken from the Longford final report, is a graphic showing the Finite Element (FE) model for the component GP905 (which was the heat exchanger that failed) depicting the area of failure when subjected to the thermal stress calculation.



**Figure 2-10: FE model of GP905**



The final report made many recommendations one was that the operators at the time had no adequate training in procedures, or understanding. They did not know what should happen when a valve is closed off or when new plant is installed. Training was inadequate and this needs to be addressed in the future.

From the above examples the issue of training and/or understanding of procedures is repeatedly mentioned. The use of graphics and computer simulations were used to explain and provide information as to what caused such disasters. This demonstrates that computer graphics and visualisation (in any form) can be a useful tool, especially for performing reconstructions and presenting information to people who have little understanding of the relevant industry, but have to make recommendations to ensure that these incidents do not happen again (e.g. an inquiry).

### ?? ***Nuclear***

Petroleum and LNG is commonly associated with the energy sectors but this thesis will briefly discuss nuclear energy as this industry has also had some major accidents and incidents

## **4 United States of America**

Three Mile Island - March 28, 1979 - The worst commercial nuclear accident in the U.S. occurred as equipment failures and human mistakes led to a loss of coolant and partial core meltdown at the Three Mile Island reactor (Figure 2-11) in Middletown (Taylor, 1999a).



**Figure 2-11: Three Mile Island reactor**

The operators were unable to diagnose or respond properly to the unplanned automatic shutdown of the reactor. Deficient control room instrumentation and inadequate emergency response training proved to be root causes of the accident (UIC, 2002).

## **5 Russia**

April 26 1986, saw the worst accident in the history of nuclear power. Fires and explosions resulting from an unauthorized experiment at the Chernobyl nuclear power plant near Kiev, USSR (now in the Ukraine) caused the spread of significant quantities of radioactive material over much of Europe. CG&V (Figure 2-12) was used to define the magnitude of this event, which again demonstrates its utility as a useful tool for providing information (Taylor, 1999a).



**Figure 2-12: Cloud dispersement diagram**

At least 31 people were left dead in the immediate aftermath of the disaster and an estimated 135,000 people were evacuated from areas around Chernobyl, some of which were uninhabitable for many years (Taylor, 1999a).

## **6 United Kingdom**

Windscale Nuclear Power Plant, Seascale, Lake District, England, was the first full-scale nuclear power station in the world. On October 7 1957, a fire in the Windscale plutonium production reactor (opened in 1956) saw the spread of

radioactive material throughout the countryside. In 1983, the British government said that 39 people probably died of cancer as a result (Taylor, 1999a).

## **Australian Minerals and Energy Industry History**

For more than 40,000 years before the arrival of the First Fleet in Sydney Harbour, Australian Aborigines had been mining the land for ochre and stone. Aborigines depended on their stone implements to gather and process their food and ochre was a vital ingredient in art (Figure 2-13) and religious practices, consequently quarries and ‘processing’ sites were developed to cater for the demand for these products; and transport routes were established to allow for their trade (Minefact, 2000).



**Figure 2-13: Aboriginal art work (Minefact, 2000).**

While ochre and stone of one sort or another can be found almost anywhere in Australia, the ochre and stone deposits that were exploited by Aborigines were of particularly high quality. The higher the quality the larger the mining operation and the greater the distance over which the product was traded. Ochre from north western South Australia and from eastern Western Australia and stone axes from Mount Isa-Cloncurry were traded far outside these districts. At times many different clans would gather near a quarry site to trade for the stone or ochre and to hold ceremonies, initiations and other important cultural events (Minefact, 2000).

Mines were generally open cut, although some mines did extend underground. At Koonalda Cave in South Australia there is evidence that flint mining extended about 75 metres below the surface and up to 300 metres from the entrance of the

cave. The quarried flint nodules from the cave were taken elsewhere to be made into tools. Operations at most major Aboriginal mines appear to have ceased no later than 50 years ago, although deposits of ochre are still being exploited for use in art and ceremonies (Minfact, 2000).

The following information from the DME (2001a) demonstrates the significant events of 'Modern' Australian mining following the arrival of European settlers on the eastern seaboard in 1788. A detailed listing of discoveries are given in Appendix 4.

?? In 1788, quarrying of sandstone for early buildings at Sydney Cove was undertaken at Hawkesbury.

?? The first discovery of coal was made by escaped convicts in the Newcastle area in 1791.

?? The coal industry began in 1798 when ship owners gathered surface coal at Newcastle and brought it to Sydney for sale. Export of Newcastle coal began in 1799 with a shipment to India.

?? Traces of metallic minerals, particularly gold, were found in the early part of the 19th century, mainly by shepherds and convicts. However, there was no concerted effort towards mining because English law demanded that all gold and silver remained the property of the Crown.

?? The first metal mined in Australia was lead from the Glen Osmond hills on the outskirts of Adelaide in 1841. This was followed by copper mining at Kapunda in the same general area in 1842.

When many Australian colonial residents migrated to the United States in 1849 following reports of rich gold discoveries in California, the New South Wales Government realised that the wave of migration needed to be reversed, so rewards were offered for the discovery of 'payable' gold.

In April 1851, the first reported discovery of payable gold was made by J Lister and W Tom at the junction of Lewis Ponds and Summer Hill Creeks, Ophir.

Over the past 100 years, 438 mine employees have lost their lives in 28 mine disasters in Australia and many more have been injured. A table listing the

disasters in which two or more persons lost their lives in the Australian mining industry is shown in Appendix 5. (Pitzer, 1999).

## **WA's Minerals and Energy Industry History**

Perth was discovered in 1697 by the Dutch navigator, de Vlamingh, who named the Swan River after the black swans he saw (Stannage, 1979). To European scholars of the 16<sup>th</sup> Century, the existence of a large undiscovered landmass in southern latitude was incontrovertible. It was held with equal conviction and as little foundation in empirical science that, when explored, *Terra Australis Nondum Cognita* would yield immense mineral riches. In 1576 an English pundit, John Dee wrote confidently that it ‘*Doth abound with gold and other things to men’s great commodity very serviceable*’ (Spillman, 1993).

In March 1827, Captain James Stirling on one of his sojourns along the Swan River drew up a list of minerals which he claimed had been “*discovered in our hasty inspection*”. Approval for settlement was given late in 1828 with Capt Stirling being appointed Lieutenant Governor. Notwithstanding a lack of interest from England in minerals, two important contemporary works of geological science were sent to Stirling. The first of these, popularly known as ‘Conybeare’s Geology’, was the Rev. W.D. Conybeare and W Phillips’ *Outlines of the geology of England and Wales*, published by Phillips in 1822. The second was by Prof. Robert Jameson entitled ‘*A system of mineralogy, in which minerals are arranged according to the natural history*’, published in 1820 (Spillman, 1993).

The Western Australia mining industry began soon after the arrival of the first settlers at the Swan River settlement in 1829 with the quarrying of limestone and digging of clay for bricks for construction of houses and roads. The following significant events indicate how the WA minerals and energy industry developed (DME 2001b):

?? In 1846, coal was found in the Murray River, south of Perth, and in the bed of the Irwin River, near Dongara. Further discoveries of minerals were also noted south of Perth, notably copper and lead deposits near Mundijong.

?? The Collie coalfield was discovered in 1883. Collie grew to become an important source of coal for the State which was used mainly for power

production in railways, shipping and generation of electricity. Today it is still the only coal producing area within WA producing electricity.

?? Gold was found near the Ord River in 1883, then at Hall's Creek and elsewhere in the Kimberley in 1886, and in 1888 rich reefs were discovered at Southern Cross. Arthur Bayley and William Ford moved eastward from Southern Cross and in September 1892, discovered the Coolgardie goldfield (Figure 2-14).



**Figure 2-14: Searching for gold (anon, 1892).**

?? In June, 1893, Patrick Hannan, along with Thomas Flanagan and Daniel Shea discovered gold at Kalgoorlie. The rush to Kalgoorlie that followed was the second of the three great goldrushes in Australia. The Kalgoorlie field remains the most significant gold-producing region in Australia.

?? The Fimiston Open Pit (also known as the Super-pit) is the largest open pit gold mine in Australia. When completed the pit (Figure 2-15) will be 4 kilometres long, 1.5 kilometres wide and 650 metres deep (Kalgold, 2001).



**Figure 2-15: Fimiston alias the *Superpit***

The Western Australia oil and gas resources were also being discovered as shown in the following:

?? In 1953 oil was discovered at Rough Range. Though the discovery was not commercial, it demonstrated that oil did exist and the tempo of exploration rose dramatically throughout Australia.

?? The mid 1960's saw the discovery and development of large iron-ore deposits in the Pilbara and rich deposits of bauxite, nickel and petroleum elsewhere in the State.

?? The discovery of a large quantity of petroleum at Barrow Island in 1964 saw the development of the State's first commercial oilfield.

?? During the 1970s the discovery of natural gas on the North West Shelf, gold at Telfer, and diamonds at Ellendale and Argyle occurred.

All of this ensured that mining became the mainstay of WA's economy. The following map of WA (Figure 2-16) shows the magnitude of resources in the state.



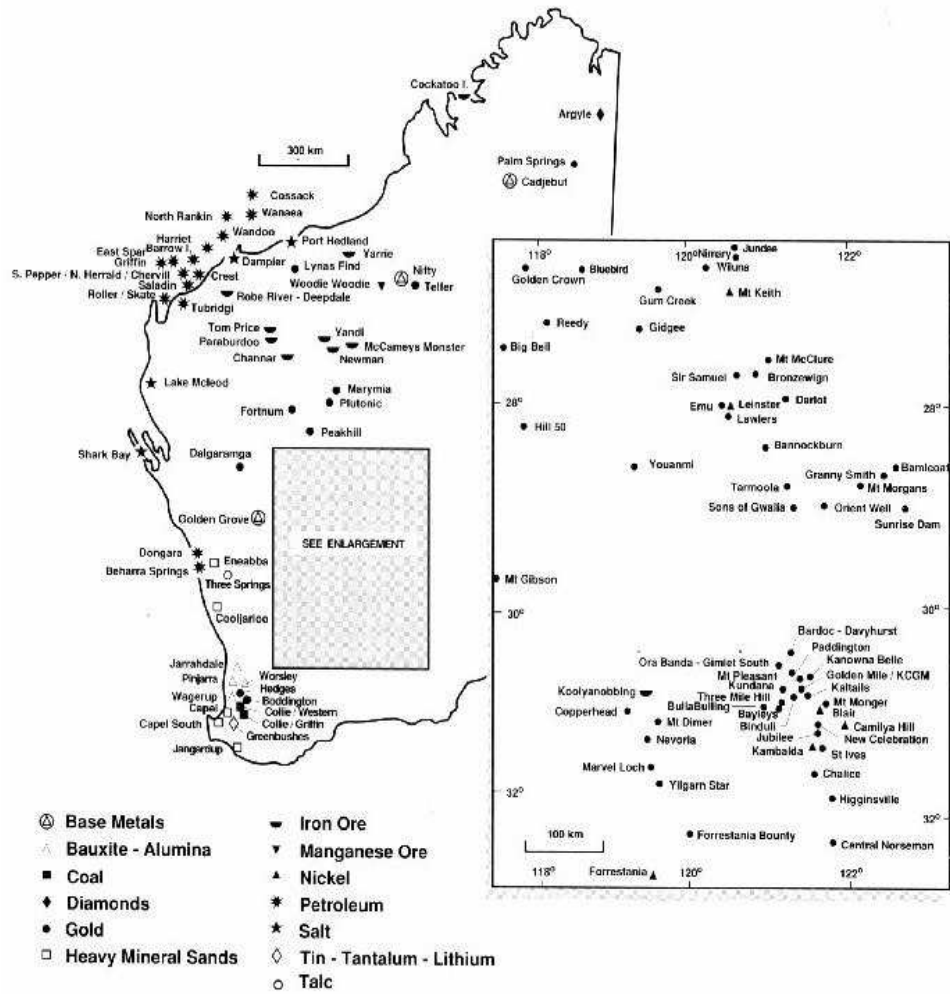

Figure 2-16: Map of WA Minerals & Energy Areas (Courtesy DoIR)

## WA's Mining Acts and Regulations

The Mining Operations Division (MOD) of the Department of Industry and Resources (DoIR) monitors the Western Australian minerals industry. The MOD use Acts and Regulations to ensure that mineral sector fulfils its legal obligations towards the State of WA and its workforce.

The following statement defines the difference between an Act and a Regulation as defined by the State Law Publisher (SLP, 2001):

### *ACT OR REGULATION and WHAT IS THE DIFFERENCE?*

*Acts and Regulations are quite different, but it can be confusing knowing which is required as they often have similar titles and deal with similar material.*

*An Act is legislation passed by the Parliament. Acts, not including schedules to Acts, can only be amended by another Act of Parliament. Acts set out the broad*



*legal policy principles.*

*Regulations, Rules, Codes etc. are commonly known as 'subsidiary legislation'. These are the guidelines that dictate how the provisions of the Act are applied. They also have pro forma official forms that are required under the Act.*

*Generally, if its the Legal statement of Law that you want then it is the Act that is required. If it is implementation detail then you need the regulation.*

The Mine Safety and Inspection Act (MSIA) 1994, places emphasis on workplace consultation between employers and employees, and recommends that safety and health representatives be elected. The general requirement for employers to consult and cooperate with safety and health representatives and other employees is a part of the employer's general duty under the Act. Similarly, employees are required to cooperate with employers in safety and health matters so that employers are able to meet their responsibilities (DME, 1999).

### **?? *Achieving the objectives of the legislation***

The MOD administers the MSIA 1994 that sets objectives to promote and improve occupational safety and health standards. General duties are laid down in the Act, and are supported by other requirements in the Act and Regulations. The Act describes behaviour required of people who affect safety and health at work. It imposes a requirement to a general duty of care to protect persons at work from hazards and maintain safe and healthy workplaces.

The Mines Safety and Inspection Regulations (MSIR)1995, made under the Act, describe some of the requirements, which apply to specific work situations. Reference is also made in the legislation to codes of practice and guidelines and to standards produced by Standards Australia and the National Occupational Health and Safety Commission.

The Act provides a framework where consultation, cooperation, regulations, codes of practice, workplace standards and procedures to resolve issues support the general duty of care. The general duty of care is the guiding principle for all other parts of the Act.

The legislative framework shown below (Table 2-1) was established to achieve the objectives of the MSIA 1994. (DME, 1999).

<p><b>Mines Safety and Inspection Act 1994</b></p>	<p>Major Provisions of the Act</p> <ul style="list-style-type: none"> <li>?? The General Duties</li> <li>?? Resolution of Issues</li> <li>?? Safety &amp; Health Representatives</li> <li>?? Safety and Health Committees</li> <li>?? Enforcement of Act and Regulations</li> </ul>
<p><b>Mines Safety and Inspection Regulations 1995</b></p>	<p>The Regulations set minimum requirements for dealing with specific hazards and for work practices, including reference to:</p> <ul style="list-style-type: none"> <li>?? National and State Standards developed by the National Occupational Health and Safety Commission and the WorkSafe Western Australia Commission; and</li> <li>?? Australian Standards developed by Standards Australia</li> </ul>
<p><b>Guidance Material not in Regulations</b></p>	<ul style="list-style-type: none"> <li>?? Codes of practice approved or adopted for Western Australia in accordance with Section 92 of the Act;</li> <li>?? Guidelines as endorsed by the Mines Occupational Safety and Health Advisory Board;</li> <li>?? National and State codes of practice and standards developed by the National Occupational Safety and Health Commission and the WorkSafe Western Australia Commission; and</li> <li>?? Australian Standards developed by Standards Australia</li> </ul>

**Table 2-1: Mines Safety and Inspection Act 1994 Framework.**

**?? Reporting accidents**

Under the MSIA specific accidents and injuries must be reported. This is defined in Part 7 of the Act - Specific Duties Relating to Occupational Safety and Health, in sections 75 to 79. Extracts of the sections can be viewed in Appendix 6.

**WA’s Petroleum Acts and Regulations**

The petroleum industry is regulated by various pieces of legislation and regulations (refer Appendix 7). The Western Australia DoIR administers the Commonwealth offshore adjacent area (Figure 2-17) under a Joint Authority arrangement as the designated authority (Petweb, 2001).

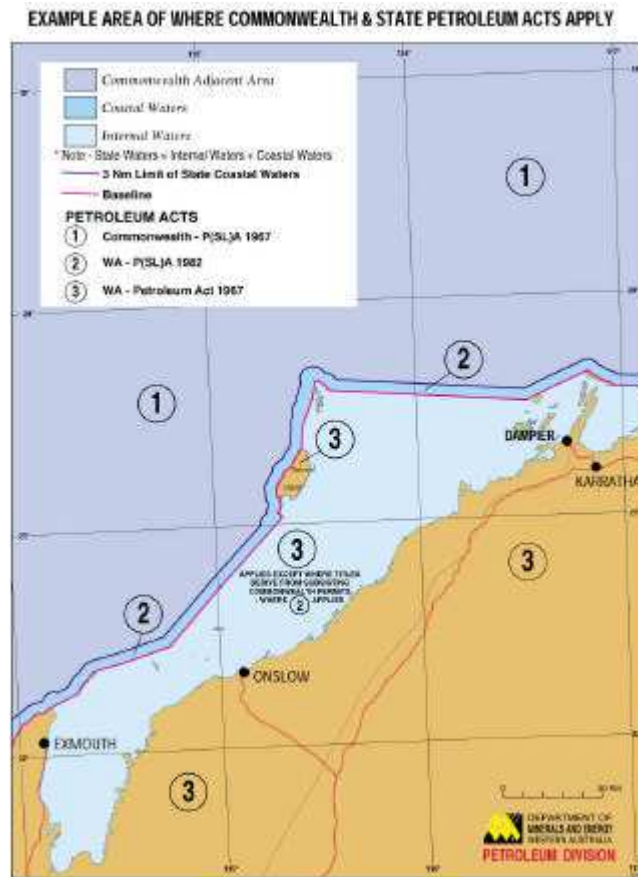

**Figure 2-17: Commonwealth & State Petroleum Acts boundaries**

**?? *Achieving the objectives of the legislation***

Operators are required to report to the DoIR all aspects of their operations as a condition for carrying out petroleum activities. Reporting is required for:

- ?? Routine compliance auditing and reporting.
- ?? Disposal of Produced Formation Water (PFW).
- ?? Hydrocarbon spills.
- ?? Other reportable incidents.

**?? *Reporting accidents***

Accidents and incidents at petroleum sites must be reported to the DoIR. Near misses must also be reported. The information is entered into a database and it is used to identify safety trends and to focus investigations. The trends and other data are distributed to industry and the general public through magazines and conferences (Petweb, 2001).

## ?? **Reporting spillages**

The reporting of incidents resulting in the spillage or escape of hydrocarbons or other contaminants from onshore operations is regulated under Clause 290 of the Petroleum Act 1967 Schedule of Onshore Petroleum Exploration and Production Requirements 1991. Under Clause 290 (1), a report to the DoIR must be made in the event of:

?? A significant spillage of hydrocarbons which in areas of inland waters is in excess of 80 litres and in other areas in excess of 500 litres.

?? A significant quantity of petroleum in a gaseous form is in excess of 500 m<sup>3</sup>.

For offshore operations under State jurisdiction, Clause 285 (1) in the Offshore Schedule stipulates reporting requirements in the event of:

?? An escape or discharge into the sea of a mixture of petroleum and water in which the petroleum concentration is greater than 50 mg l<sup>-1</sup>.

?? An escape or discharge into the sea of more than 80 litres of petroleum.

All incidents are required to be reported to the DoIR's Manager for Safety and Environment and the DoIR's Manager for Exploration and Production under Clause 285 (2) of the Offshore Schedule as outlined above (Petweb, 2001).

## **Training in the Minerals and Energy Sector**

Training in the minerals and energy sectors does require a person to have completed an induction training course before they start work.

To obtain certain positions requires specific training for example:

?? To be employed as mine supervisor you must hold a mine managers certificate, to obtain this you need to have completed a degree in mining (or equivalent).

?? To be a drilling rig offsider you must have (or in the process of obtaining ) a basic competency level e.g. Level 1 Competency Certificate.

The one consistent factor in training for the minerals and energy sector in WA is at that all people employed must undergo an induction course. Each site is different so if a person works at many sites they will be required to undergo each of the site specific induction course. These courses usually last 2-4 hours. The

question that must be asked is once a person has been employed in these hazardous environments and undergone the induction course for that site, then what other training is available.

The following will demonstrate some of the methods used to provide training.

### ?? ***Traditional methods***

Each industry has their own manner of providing training to their employees. The following are the more traditional methods that are currently used.

?? Induction courses – these are usually half day sessions to new employees explaining to them the company’s safety and health policy as well as specific information relevant to that company or minesite e.g. if the evacuation alarm is activated the ‘mustering’ and assembly points must be known.

?? Toolbox or Safety meetings – these are usually 5 – 15 minute talks to small groups of workers. They take place on site and just before the employees start work or in remote areas during a ‘practical stopping/resting’ time. They are conducted by the safety officer or a representative to inform workers of a specific problem that is of concern or as a reminder of some safety practices such as *‘remember to apply sun block at regular intervals and drink lots of water’*.

?? Safety publications – these are generally text based and presented as safety bulletins, safety alerts or monthly magazines. They are produced primarily by a government agency or industry associations for the industry and are usually located in the ‘common’ room of the workplace or a public area for reading. The following are good examples:

MINESAFE - a magazine produced by the DoIR (Appendix 8) that contains local and international health and safety information, articles on current incidents that are of concern to the DoIR and MOD, as well as information relating mining legislation.

SAFETY Notices – these are also DoIR publications produced by the relevant division highlighting safety issues or as information on problems or accidents/incidents that have recently occurred in the industry. Figure 2-18

presents two safety notice one for the petroleum industry and the other for mining. These are released under the authority of the Director of each division

**SAFETY BULLETIN**

**HEALTH MONITORING**

A recent mine accident on a petroleum installation resulted in a person being hospitalized a few days later.

The injuries sustained in the accident were small enough to allow the person to return to work after seeing the Medix. His condition deteriorated in the course of a few days to such an extent that he had to be evacuated to be treated by a doctor.

The potential effect on his recovery, of the medication he was taking for a medical condition at the time of the accident, was not initially recognized.

DME wants to stress that it is the employer's responsibility to:

1. Maintain up-to-date records for all employees of their medical condition and any medication being taken.
2. Assess employees' ability to safely perform assigned tasks, given any medical condition and/or medication.

Similarly, it is the responsibility of employees to report to the employer any changes in their health and any medication being taken that may affect their ability to perform work safely.

**W. L. Tinapple**  
DIRECTOR, PETROLEUM DIVISION

15 February 2000

Department of  
Mineral and Petroleum Resources

Petroleum Division  
Tel: (08) 9222 3622  
Fax: (08) 9222 3709

WESTERN AUSTRALIA

Significant Incident Report No. 110

**VEHICLE OVER SLOPE EDGE**

**INCIDENT**

A Toyota personnel carrier was reversed into an ore drive in an underground mine, where it went over the bench edge of an open slope. Fortunately, the vehicle became stuck on the edge and it enabled the driver to exit the vehicle. The driver attempted to secure the vehicle with chain but it slipped entirely over the edge and fell 15 m into the slope drop-off on the level below.

The driver was barely shaken by this incident and was fortunate not to have sustained serious or fatal injuries.

**CAUSES**

- The entrance to the ore drive leading to the slope was not cordoned off with a physical barrier;
- The mine relied on the placement of a chain and sign to warn of the presence of a vertical opening into a slope. In this case, the chain and sign was not in place;
- Risks associated with slope vertical openings had not been fully assessed;
- The driver was unaware of the position of the bench edge in the drive. It had been advanced approximately 34 m during his H & R break;
- Poor visibility to the rear of the vehicle.

**COMMENTS AND PREVENTATIVE ACTION**

To avoid a recurrence of this type of incident, the following actions need to be considered:

- Assess current work practices and procedures and ensure that safe systems of work that include appropriate precautions are in place which will minimise any risk of injury to any persons working at, or accessing, vertical opening locations.

Refer to MSR 1995 regulation 10.35, and to the MOSHAB guideline "Vertical Opening Safety Practice."

**ThinkSAFE MineSafe**

Department of Mineral & Petroleum Resources  
March 2 August 2001

Page 1 of 2

Figure 2-18: DoIR safety notices

?? Safety Videos – these can be broadly based or produced on specific themes and are currently used in all areas of the minerals and energy sectors to disseminate information. Figure 2-19 demonstrates examples of videos available: the Bristow helicopter video is used to instruct passengers on the emergency safety procedures where as the Boral video explains the 3-point contact principle when ascending and descending and the implications of a potential injury.



Figure 2-19: Safety videos

?? Computer Based Training (CBT) – requires computer access. Personal computers are not always available on remote minesites, however some oil and gas offshore platforms have the relevant facilities. This form of training is usually available to be undertaken at work or at home. Figure 2-20 demonstrates examples of applications. The ‘scraper’ application provides information on how to operate a scraper and its uses. The coal industry provides training packages and example assessments for gaining competency levels in this industry.



Figure 2-20: CBT applications

The National Institute for Occupational Safety and Health (NIOSH) Spokane Research Laboratory (USA) are currently undertaking the following tasks:

?? To create training tools relevant to metal/nonmetal mines (using video).

?? To introduce multimedia presentation as a tool to provide training to the new generation of miners.

There has been a large demand for the video, requests are received continually by NIOSH pointing to a much greater need than had been anticipated. The multimedia and prototype VR applications have also been well received. Beta tests have shown these forms of training are very popular with younger miners (Cullen, 2000).

### ?? ***Training as required by the WA mining regulations***

The Western Australian Mines Safety and Inspection Regulation 1995 requires that each employee is:

?? Given adequate instruction and training in safety procedures and systems of work and in the tasks required of the employee.

?? Assessed before commencing work at the mine to ensure that the employee is competent to perform the tasks he or she will be assigned and to operate any plant and equipment the employee will be required to operate.

?? Retrained and reassessed whenever systems of work or plant and equipment are changed, or new systems or work or plant and equipment are introduced.

It is important to note that these provisions include a requirement for assessment to ensure competency, and require reassessment when operational systems or tasks change. Recording of training, retraining and reassessment is also required (Torlach, 2000).

The following statement from DoIR's, MOD, Safety Bulletin No. 40, 27/05/1998 summarises the justification of pursuing such works.

*The jury found that death arose by way of accident, but evidence led at the inquest prompted the Coroner to issue the following riders, which were recommended by the jury:*

*(1) An induction process should include a mechanism to evaluate the inductee's understanding of the material covered. The process should include provision for regular re-assessment of employees' knowledge of induction material.*



*(2) Operator competence should be assessed on a regular basis, especially where tasks or procedures change.*

*It appears from this recommendation that the jury were mindful of the influence, which induction training and competency assessment processes may have had with respect to the occurrence of this particular accident. Their concern in this regard (which is shared by the inspectorate) has prompted them to draw the attention of the mining industry to this potential hazard with a view to preventing further deaths in similar circumstances.*

The above statement demonstrates that training is not only a requirement by legislation but accepted by the general public and industry as a way of keeping employees informed.

## **Conclusion**

There has been significant occupational health and safety (OH&S) changes made in the mineral and energy sectors primarily due to some large scale disasters. The inquiries that have followed and the recommendations that they made, have mostly been incorporated into the OH&S practices of today's minerals and energy sectors.

This chapter briefly looked at the Australian and the Western Australian minerals and energy sector from its beginning through to legislation and training.

The disasters of the industry have been documented in many ways using the technology or skill of the day, from hand drawn pictures through to current day digital photographs and video captures. The use of visualisation methods to document and assist in explaining the events is well documented and is considered to be the "norm" for any current disaster or event. The following chapter looks at the start and current use of computer graphics and visualisation.

## 3 COMPUTER GRAPHICS AND VISUALISATION

### Introduction

This chapter reviews the currently available literature for computer graphics and visualisation (CG&V). Given that the subject areas are very broad, attention is paid to relevant issues within the scope of the work covered, the role and application of computer graphics and visualisation from its early beginning to current day usage. It identifies the various forms of simulation and virtual environments and defines appropriate aspects of CG&V technology

### History of Visualisation

Language existed long before written text, emerging probably simultaneously with abstract thought and the Genus Homo. In Ryan's (1997) opinion, the signature event that separated the emergence of palaeohumans from their anthropoid progenitors was not tool-making but a rudimentary oral communication that replaced the hoots and gestures still used by lower primates. The transfer of more complex information, ideas and concepts from one individual to another, or to a group, was the single most advantageous evolutionary adaptation to another for species preservation. As long ago as 25,000-30,000 years BC, humans were painting pictures on cave walls. Whether these were telling a 'story' or representing some type of 'spiritual house' or ritual exercise is not known (Ryan, 1997).

When we talk about visualisation, in our present society, we predominantly think of computers. Visualisation actually goes back through the centuries to these early visual markings made on walls followed much later by printing and then television.

### ?? **Art**

Art comes in many forms and Michael Wood described it this way;

*A survey of Western art (as compared to African or Indian) could begin in one of many places - the caves of Lascaux or Altamira, Stonehenge, Mycenae, even ancient Egypt (Wood, 1989).*

We see images everywhere in our daily lives; we absorb them unthinkingly, indeed, they have helped to shape the way we see (Hooker, 1989).

The artist is not simply a blank eye registering and recording optical impression but a person involved in shaping and organising intelligence whose choices tell us a great deal about the society in which they are working and their own attitude to that society.

We assume that the art of the past is a kind of cultural symbolism, a form of shorthand which helps us to understand those times - but how does modern art connect with all that past? And in a society dominated by television, film, video and the electronic media, does art nowadays have anything significant to say? Art then is, above all a product of its own time, of beliefs, the social order and the means of production of that time (Hooker, 1989).

In Australia 'The Dreaming' is a term used by Aborigines to describe the relationship and balance between the spiritual, natural and moral elements of the world. Many artworks are visual representations of the symbols associated with the artist's dreaming. Figure 3-1 is named *Daughter of the original female rainbow serpent*, by Bardyal Nadjamerrek. The painting of *The Rainbow Serpent* first appeared in Arnhem Land rock art more than 6000 years ago (Tacon et al, 1996).



**Figure 3-1: The rainbow serpent**

The Dreaming relates to a period from the origin of the universe to a time before living memory or experience - a time of creator ancestors and supernatural beings. 'Dreaming' is often used to refer to an individual's or a group's set of beliefs or spirituality. For instance, an Aboriginal Australian might say that they have

Kangaroo Dreaming or Honey Ant Dreaming, or any combination of Dreaming pertinent to their 'country' (Tacon et al, 1996).

The use of art as a mechanism for delivering information required patience and time. In the case of cave paintings people travelled to the site to view the image (information). If the painting was on canvas then portability was available but still restrictive as there was only one original. In both cases interpretation of the painting was either left to the individual or provided by a storyteller or interrupter, both subject to distortion, exaggeration and misinformation.

### ?? **Writing**

The advent of a writing system, seems to coincide with the transition from hunter-gatherer societies to more permanent agrarian encampments when it became necessary to count ones property, whether it be parcels of land, animals or measures of grain or to transfer that property to another individual or another settlement.

Around 4100-3800 BC, tokens began to be symbols that could be impressed or inscribed in clay to represent a record of land, grain or cattle and a written language was beginning to develop. The pictures began as representing what they were i.e. pictographs, and eventually certain pictures represented an idea or concept i.e. ideographs, and finally to represent sounds (Ryan, 1997).

Written language was the product of an agrarian society, These societies were centered around the cultivation of grain. A natural result of the cultivation and storage of grain is the production of beer. It is not surprising, therefore, that some of the very oldest written inscriptions concern the celebration of beer (Figure 3-2) and the daily ration allotted to each citizen (Ryan, 1997).

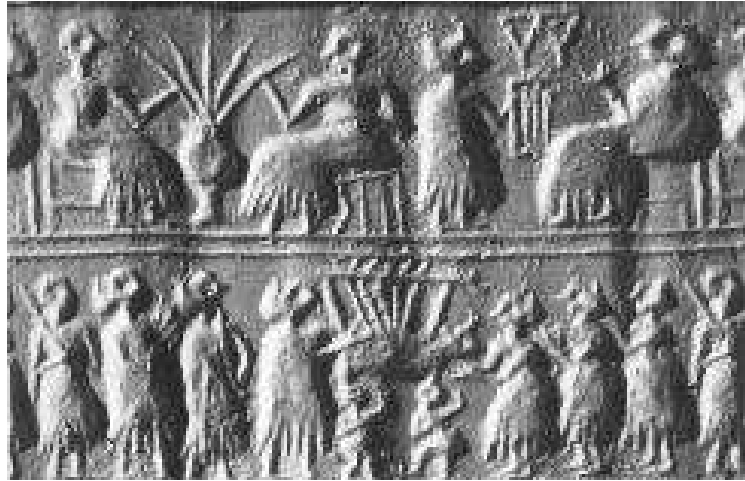

**Figure 3-2: Early cylinder seal depicting beer production**

While cuneiform was spreading throughout Mesopotamia, a different writing system was being developed in nearby Egypt. From about 3000 BC the Egyptians used a form of beautifully stylised picture writing called hieroglyphics (Writing of the Gods). There were signs for objects, ideas and sounds, including a basic alphabet of 24 signs that stood for separate letters. More than 5000 years ago Egyptian scribes were already using paper (papyrus) pen and ink and we see their writing (Figure 3-3) today in tombs and temples along the banks of the river Nile (Parker, n.d.).



**Figure 3-3: A picture and writing**

The Phoenician alphabet was adopted by the early Greeks who earned their place in alphabetic history by symbolising the vowels. Therefore the Hebrew, Aramaic and Greek scripts all came from the Phoenician. The Greek alphabet led to Latin and Cyrillic. Aramaic led to Arabic and most of the scripts used in India. The entire Western World became inheritors of those beer drinkers in Mesopotamia and the turquoise miners in Sinai (Ryan, 1997).

Writing is now much easier than it used to be. We no longer have to cut our own pens from lengths of bamboo or feather quills, or make our own paper from reeds or animal skins (Parker, n.d.).

## ?? **Printing**

The Chinese development of paper making also led them in the ninth century to develop moveable type. They did this by setting characters in wood blocks. While the Chinese language's reliance on up to 40,000 characters made moveable type impractical, Western inventors later began modifying this centuries-old printing process using moveable type.

In 1450, a German artisan from a small town called Mainz, Johannes Guttenberg originated a moveable type method that printers used until the 20th century. Guttenberg punched 264 characters into the ends of steel punches, which were inserted into copper blanks. His next innovation was transforming a wine press into a machine suitable for printing, and using, heated oil, resin and soap, Guttenberg also made ink which introduced printing as a new form of mass communication (Inventing Printing, 1999).

Gutenberg's bible (Figure 3-4) consisted of 641 sheets with most of its pages containing forty-two lines in two columns. All in all there were 1,282 pages bound in two volumes. In 1474 an account was written that described Gutenberg as printing three hundred sheets a day using six presses. About three hundred copies were printed with the binding done elsewhere with some copies being sold as separate sheets (Figure 3-4). The bible was printed in ten sections, which means that Gutenberg had to have enough type to set up about 130 pages at a time. This translated into nearly four hundred thousand pieces of type needed, a huge investment of time and metal (Panagakis et al, 1997).



Figure 3-4: A page from the Gutenberg bible

Gutenberg's bible was a large project by any day's standards, but particularly by those in the mid 1400's. Setting each letter by hand, placing each sheet in the press and then taking it out to dry only to insert it again to be printed on the reverse side, was a mammoth undertaking (Inventing Printing, 1999).

With all this 'new' technology being available and with education and literacy skills on the increase, when an event or incident occurred, the print was able to disseminate the information using text and pictures.

An example of the widespread use of printing occurs in England early in the 20<sup>th</sup> Century, The Penny Magazine, (Figure 3-5) was published every Saturday, and was aimed at the working class (Corrie, 1995).

Monthly Supplement of  
**THE PENNY MAGAZINE**

OF THE  
Society for the Diffusion of Useful Knowledge.

192.]

February 28 to March 31, 1835.

THE COLLIERIES.—No. I.

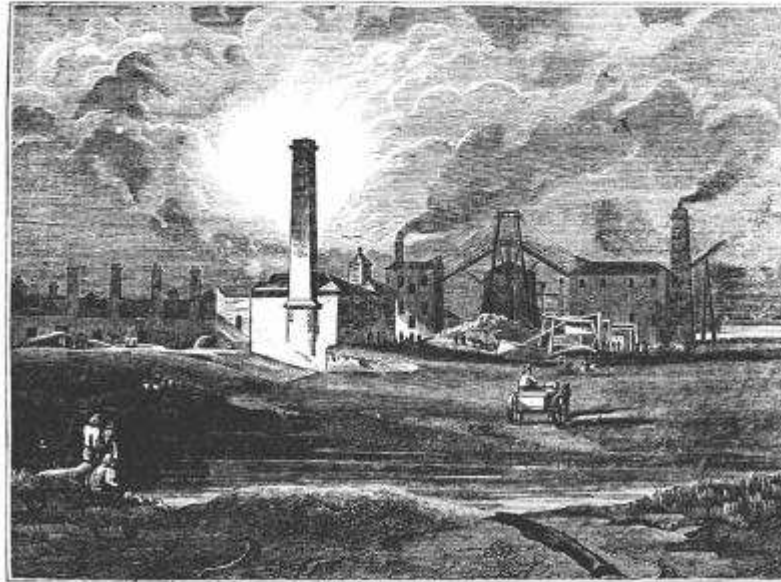

[South Hutton Colliery.]

**Figure 3-5: Cover of Penny Magazine Feb 28, 1835**

It was part of the Society for the Diffusion of Useful Knowledge's program for liberal reform. For its reader, however, it was a source of information on subjects of general interest: everyday things like tea and coffee, well-known places in England, and included a series on animals and birds of Britain, and descriptions of present-day manufacturing (Corrie, 1995).

Printing therefore, provided a mechanism for quick dissemination of information to a large number of people.

### ?? **Photography**

Sir John Herschel, first used the name Photography in 1839, the year the photographic process became public. The word is derived from the Greek words for light and writing. William Talbot produced a paper negative in August 1835, it was of poor quality and measured 1 inch square. However, Talbot subsequently made some significant improvements, and by 1844 was able to bring out a photographically illustrated book entitled 'The Pencil of Nature' (Leggat, 2000).



Celluloid was invented in the early eighteen-sixties, and John Carbutt persuaded a manufacturer to produce very thin celluloid as a backing for sensitive material. George Eastman is particularly remembered for introducing flexible film in 1884. Four years later he introduced the box camera, and photography could now reach a much greater number of people (Leggat, 2000).

Of specific relevance to the technology described in this thesis is the use of photography to depict three-dimensional depth.

### Anaglyphs

Figure 3-6 demonstrates an anaglyph and how you view the final image in 3D.

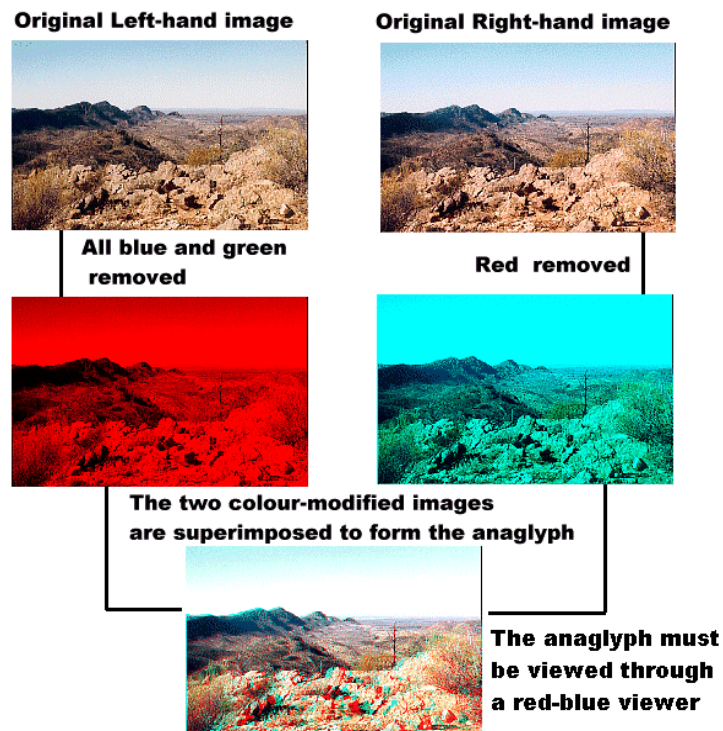

**Figure 3-6: Anaglyph process**

In 1835 W. Rollman first illustrated the principle of the anaglyph using blue and red lines on a black field with red and blue glasses to perceive the effect, but this was for line drawings only. In 1858 Joseph D'Almeida began projecting three-dimensional magic lantern slide shows using red and green filters with the audience wearing red and green goggles (Leggat, 2000).

Louis Ducas du Hauron produced the first printed anaglyphs in 1891. This process consisted of printing the two negatives, which form a stereoscopic

photograph on to the same paper, one in blue or green and the other in red.

To look at the pictures you would look through a viewer made up of coloured glasses, with red (for the left eye) and blue or green (right eye).

The left eye would see the blue image that would appear black, whilst it would not see the red; similarly the right eye would see the red image, this registering as black. Therefore producing a three dimensional image (Leggat, 2000).

### Stereoscopy

In 1613 the Jesuit Francois d'Aguillion (1567-1617), coined the word 'stéréoscopique' The idea of stereoscopy actually preceded photography. Binocular drawings were made by Giovanni Battista della Porta (1538-1615), about the same period Jacopo Chimenti da Empoli (1554-1640) produced drawings side by side which clearly indicated his understanding of binocular vision. Stereoscopic or 3D photography works because it is able to recreate the illusion of depth.

Most associate Sir David Brewster with the invention, but it was Sir Charles Wheatstone who, in June 1838, gave an address to the Royal Scottish Society of Arts on the phenomena of binocular vision. The conventional method of viewing stereoscopic photographs in the last century was to use a viewer which held a pair of images, and which enabled each eye to see only one; by fusing these together a 3D effect was recreated (Leggat, 2000).

### ?? **Television**

As early as 1875 George Carey of Boston suggested sending a picture over multiple circuits, but others like W.E. Sawyer proposed transmission of images over a single wire or channel by rapidly scanning picture elements in succession.

John Logie Baird was born on August 13th, 1888, in Helensburgh, Dunbartonshire, Scotland and died on June 14, 1946 and is remembered as being an inventor of a mechanical television system. In the 1920's, Baird and the American Clarence W. Hansell patented the idea of using arrays of transparent rods to transmit images for television and facsimiles respectively. Baird's 30 line images were the first demonstrations of television by reflected light rather than

back-lit silhouettes. Baird based his technology on Paul Nipkow's scanning disc (Figure 3-7) idea and later developments in electronics (Bellis, n.d.).

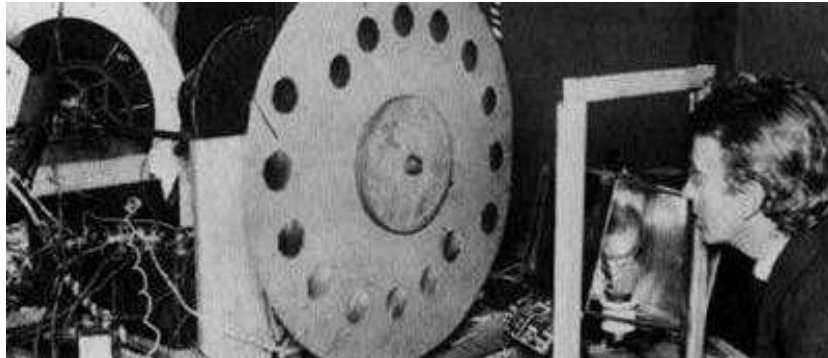

**Figure 3-7: Nipkow's scanning disk.**

This television pioneer created the first televised pictures of objects in motion in 1924, the first televised human face in 1925 (Figure 3-8) and a year later he televised the first moving object image at the Royal Institution in London (Bellis, n.d.).

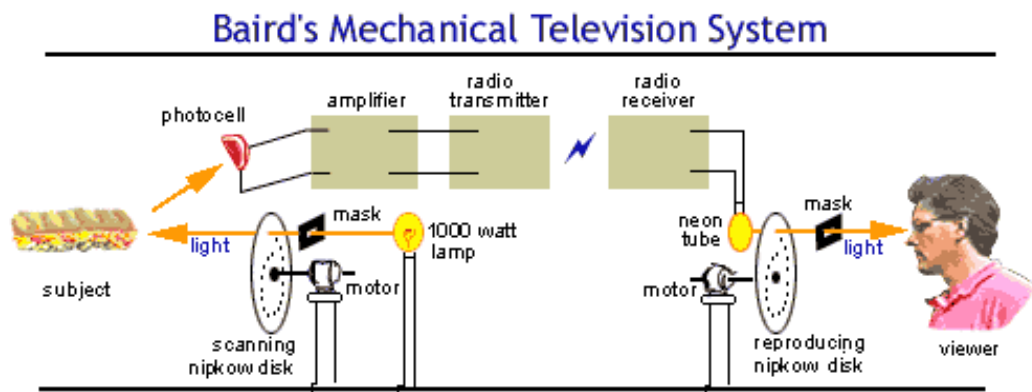

**Figure 3-8: Baird's mechanical television diagram**

His 1928 trans-atlantic transmission of the image of a human face was a broadcasting milestone. Colour television, stereoscopic television and infra-red light were all demonstrated by Baird before 1930. He successfully lobbied for broadcast time with the British Broadcasting Company (BBC) and the BBC started broadcasting television on the Baird 30-line system in 1929. The first simultaneous sound and vision telecast was broadcast in 1930. In July 1930, the first British Television Play was transmitted, *'The Man with the Flower in his Mouth'* (Bellis, n.d.).

Vladimir Zworykin, (a Russian-born American) was working with Pittsburgh's Westinghouse Electric Corporation, where he invented the iconoscope in 1923, a tube for television transmission. The iconoscope was later replaced but laid the foundations for early television cameras. The iconoscope allowed pictures to be electronically broken down into hundreds of thousands of elements. In 1929, Zworykin demonstrated how television would work with his kinescope, or cathode-ray tube. Zworykin's model for television (Figure 3-9) was quite different from the television watched today with the display screen being only one square inch (Mills, 1999).



**Figure 3-9: Zworykin demonstrating TV in 1929**

In 1930, Philo Taylor Farnsworth was the first to transmit a television image comprised of 60 horizontal lines. The image transmitted was a dollar sign, quite appropriate considering the amount of revenues that television would bring in the decades to come.

In 1932, Zworykin's iconoscope (Figure 3-10) was able to imitate the way that the human eye viewed images for television broadcast. After joining the Radio Corporation of America, Zworykin developed designs for colour television, but in his life's later years, television's trivialisation of everyday life disturbed the inventor, who favoured using television as a cultural enrichment and learning tool (Mills, 1999).



**Figure 3-10: Iconoscope diagram**

In the 1950's Hollywood wanted to give the public a reason to buy a cinema ticket instead of staying at home and watch their sets. They tried a lot of ideas, some good and some bad, but one idea that still works today is the widescreen format. Wider screens, such as *Cinerama*, *Cinemascope*, and *VistaVision*, give the theatre audience a more visually engulfing experience. Because our two eyes give us a wider view, a wider movie makes more sense.

Like the widescreen movie formats, the High Definition Television (HDTV) screen is formatted much closer to the way we see. Our field of vision is more rectangular than square. So, when we view movies in widescreen format, the image fills more of our field of vision and has a stronger visual impact. After a few decades of experimenting with ratios, the most common theatre screen aspect ratio is 16:9 (Figure 3-11). HDTV is going to use the same aspect ratio. However, that's only part of HDTV. Besides a wider screen, the picture is going to have more detail and crisper images. With the bigger pictures comes a finer resolution (Bellis, n.d.).

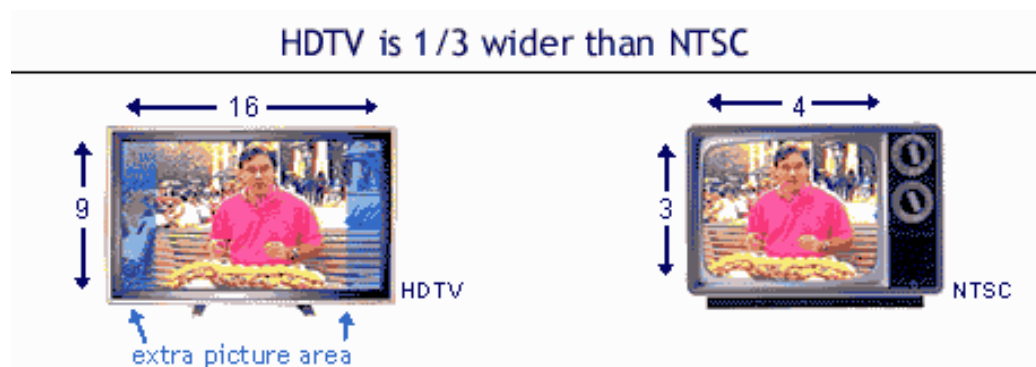

**Figure 3-11: High definition and standard TV ratios**

The above information has demonstrated the advancements in how picture information has been presented from early cave paintings through to high definition wide screen digital TV. Engineers, scientists and other professions have also capitalised on the value of pictures and other visualisation methods by expressing the results of their ideas, design work and calculations in the form of engineering drawings, charts and graphs (Demel, 1984).

To follow on from this and demonstrate how technology has helped progress visualisation we must see where Computer Graphics (CG) started and how.

## **History of Computer Graphics**

When people talk about the history of CG you would normally start with the *age of Sutherland* in this case we will look very briefly at the pre-history of computer graphics.

The foundations of computer graphics as mentioned in *The Short History of Computer Graphics* (Florida Tech, 2001) can be traced to artistic and mathematical ‘inventions’ for example;

?? Euclid Icirca (300 – 250 BC) who’s formulation of geometry provides a basis for graphics concepts

?? Filippo Brunelleschi (1377 – 1446) architect, goldsmith and sculptor who is noted for his use of perspective.

?? Rene Descartes (1596 – 1650) who developed analytical geometry, in particular coordinate systems which provide a foundation for describing the location and shape of objects in space.

?? Gottfried Wilhelm Leibniz (1646 –1716) and Isaac Newton (1642 – 1727) who co-invented calculus that allows the description of dynamical systems.

?? James Joseph Sylvester (1814 – 1897) who invented the matrix notation.

The term computer graphics was first used in 1960 by William Fetter to describe new design methods he was pursuing at Boeing.

In 1966 William Fetter defined computer graphics this way;

*Perhaps the best way to define computer graphics is to find out what it is not. It is not a machine. It is not a computer, nor a group of computer*

*programs. It is not the know-how of a graphic-designer, a programmer, a writer, a motion picture specialist, or a reproduction specialist.*

*Computer graphics is all these - consciously managed and documented technology directed towards communicating information accurately and descriptively.*

During this same period, Ivan Sutherland's work was establishing him as a leading researcher in the computer science field. In 1960, he produced Sketchpad: A Man-Machine Graphical Communication System, for his doctoral dissertation (Figure 3-12). The dissertation has been described as a major contribution to computer graphics knowledge because, up to that time, computer graphics had dealt exclusively with 2D pictures of objects. Ivan's dissertation dealt with the objects themselves and used a data structure that was based on the topology of a 3D object and described the relationships between the parts of the object (Evans and Sutherland, 2001).



**Figure 3-12: Sutherland at the console - Sketchpad project MIT 1963**

Sketchpad pioneered the concepts of graphical computing, including memory structures to store objects, rubber-banding of lines, the ability to zoom in and out on the display, and the ability to make perfect lines, corners, and joints. This was

the first GUI (Graphical User Interface) long before the term was coined (Sun Microsystems, 1994).

A goal of visualisation (computer graphics) is to capture the dynamic qualities of systems or processes by using representative moving images. In the 1980s, borrowing as well as using many of the special effects techniques of Hollywood, scientific visualisation moved into animation. In 1990, the National Centre for Space Aeronautics' award-winning animation of smog descending upon Los Angeles influenced air pollution legislation in the state. This animation was a compelling testament of the value of this kind of imagery, however the animation had severe limitations. Firstly, it was costly. After months of elaborate computer simulations, the smog animation itself took six months to produce from the resulting data; individual frames took from several minutes to an hour. Secondly, it did not allow for interactivity, that is, for changes in the data or conditions governing an experiment that could produce immediate responses in the imagery. Once completed, the animation could not be altered (University of Illinois, 1995).

## **Computer Graphics and Visualisation**

CG&V are used in many modern applications for example, movies, business, demonstrations, presentations, cartoons, videos, brochures and papers, but they all have one thing in common, the graphics generated are used for visual effects.

Accurate 3D geometry can be produced using conventional Computer Aided Design (CAD) software. A range of texture maps are then applied to the solid 3D CAD objects. Lighting conditions are then defined and objects are viewed from a range of different camera positions (Denby et al, 1998).

Visualisation, and more specifically computer-generated visualisation is used to a great extent in almost all areas of human endeavour with often immeasurable gains. One example is the field of scientific and data orientated visualisation which makes extensive use of computer generated images to view complex data sets and visualise phenomena which are otherwise invisible (Young, 1996).

The term Visualisation as used in this thesis, can be defined as a set of hardware and software tools that allows the user to:

?? View static computer graphics



?? Use various techniques and equipment to construct, develop and present data and information.

?? Realistically simulate interaction with virtual objects which are computer models of real objects.

### ?? **Entertainment**

The debut of computer graphics (CG) in film came in the 1976 film *Future World*, featuring Peter Fonda. In this film, only Fonda's computer generated hand and head showed in the background. At that time the film industry would not invest any money in these technologies because they could not benefit the plot of their film (Images United, 1997).

It was not until 1982 that CG entered mainstream cinema, when *Star Trek II - The Wrath of Kahn* was released. That movie contained sixty seconds of full-colour CG. In the sequence, called the '*Genesis Effect*', a lifeless planet was hit by a missile which caused incineration and flames across its entire surface of the sphere as the camera zoomed in tight. Compared with today's movies, this one-minute piece may seem a small accomplishment. However, this remarkable scene, created by Lucasfilm's Computer Division represents many firsts. It required the development of several new CG tools, including one for creating convincing computer fire and another to produce complex and realistic mountains as well as shorelines from surface equations (Images United, 1997).

In 1982, Disney Productions released *TRON* (Figure 3-13) as a feature film production. There were 15 minutes of computer generated footage and 68 minutes of effects in *TRON* (Patterson, 1982).



**Figure 3-13: TRON the movie released**

The magnitude of the work on *TRON* resulted in 53 minutes of edited live action black-and-white footage to be composited with backgrounds and effects via backlit animation. This required 76,320 frames (24 frames per second) of which each had to be enlarged and two copies made to allow the adding of the elements required for effects animation and additional characters. When completed there was over 400,000 elements for the animation stand (Patterson, 1982).

A popular question in the movie industry at the moment is whether digital actors will totally replace real ones in the movies someday. This might not happen in the near future, but it could come a reality with the continual advancement of high performance computers, software and the development of new techniques. For example, the idea of a virtual pop star was first conceived at HoriPro in 1995, when the company was looking into developing new multimedia software, and decided on a virtual '*aidoru keshu*' (idol-singer). The model was made up of 40,000 polygons, and employed as many as 10 programmers just to work on her face alone. When photographs of her were first sent to magazine publishers, she was even mistaken for another popular singer. Kyoko Date (Figure 3-14), named DK-96, for '*Digital Kids, 1996*', was given a stage name, a biography, a birth date, a blood type, hobbies, and a family in Fussa, Japan (Yoshi, 1998).



Figure 3-14: Kyoko Date front cover of magazine

With the developments of higher performance computers, better graphic cards and software, the creation of feature movies where all the characters are computer generated was only a matter of time.

The movie *Final Fantasy* from Columbia Pictures/Square Pictures was released in 2001, the whole movie was computer animated (Figure 3-15) using Maya and Renderman software (Square, 2000).



Figure 3-15: Final Fantasy scene

This was not an animation as in the Walt Disney animated style such as *Beauty and the Beast*. The *Final Fantasy* characters (Figure 3-16) were very life like and attracted acting talent, such as Alec Baldwin, Ming Na, Donald Sutherland for the voice overs (Square, 2000).



Character AKI



Character Neil

**Figure 3-16: Final Fantasy characters**

## ?? **Industry**

Interactivity would have remained wishful thinking if not for the development of high-performance computers in the mid-1980s. These machines provided the speed and memory for programmers and scientists to develop advanced visualisation software programs. By the end of the 1980s, low-cost, high-resolution graphic workstations were linked to high-speed computers, which made visualisation technology more accessible.

The predominant discussion within the following section on industrial computer visualisation concerns minerals and energy related applications. The development of technology within this section is similar to that in most other industries

## **7 Computer Aided Design (CAD)**

CAD software is commonly used for drafting architectural and engineering drawings and for making technical illustrations of any kind. CAD enables you to prepare fast and accurate drawings. It provides flexibility to change drawings with minimal effort. In recent years, many professionals have switched from the manual process of drawing and designing to CAD to enjoy the benefits of this



precise and creative tool. As a result, CAD has become very important to all professionals involved in the field of design and drafting.

## 8 Geographic Information System (GIS)

Itami and Raulings (1993) provide the following definition of a GIS:

*A Geographic Information System (GIS) is a computer program for storing, retrieving, analysing, and displaying cartographic data.*

Figure 3-17 demonstrates how different information is layered over the same geography. The information in these GIS examples shows ‘Driving Alone to Work’ and ‘Management and Professional Occupations’ in Hawaii (Hawaii Gov, 2002).

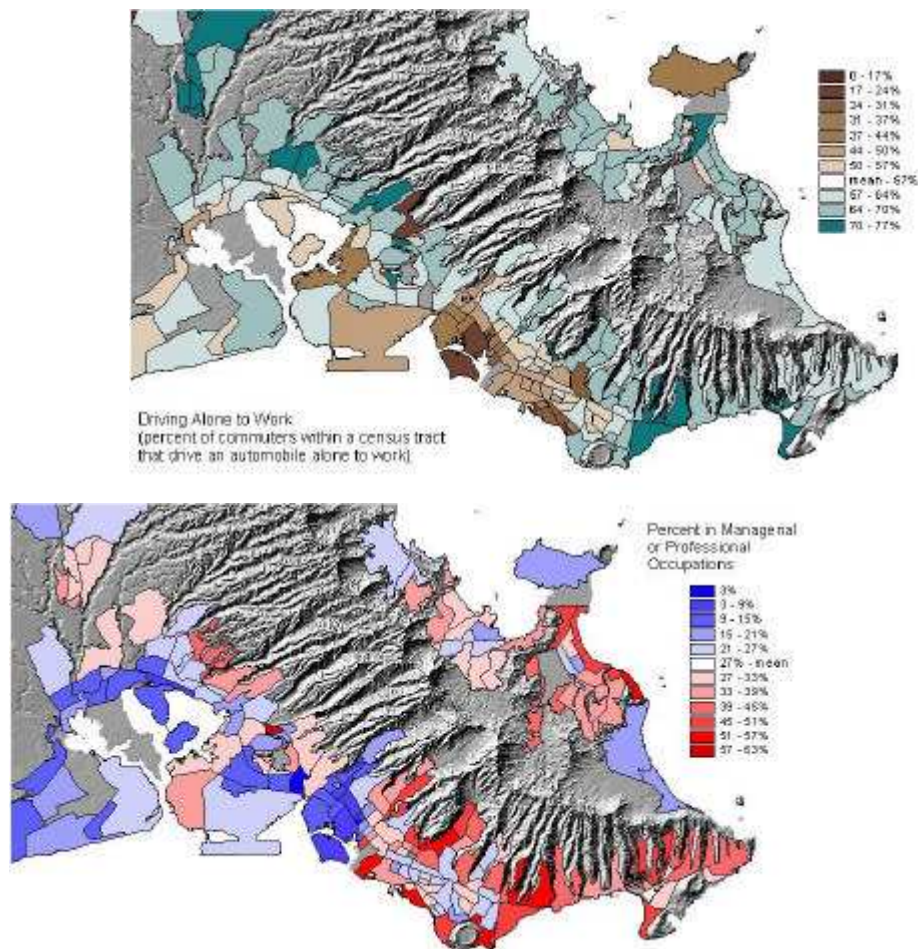

**Figure 3-17: GIS is layering information**

On the walls of caves near Lascaux, France, Cromagnon hunters drew pictures of the animals they hunted 35,000 years ago. Associated with the animal drawings

are track lines and tallies thought to depict migration routes. These early records followed the two-element structure of modern GIS: a graphic file linked to an attribute database.

The following list provides additional examples where GIS has been used:

?? Positioning legislative district boundaries.

?? Deciding which pockets of endangered environment should be protected.

?? Predicting the impact of waste facilities on local health patterns.

?? Planning restocking of native species.

?? Preparing to service the local and surrounding population in the event of various possible disasters?

The following two examples briefly describe how GIS has been used in relation to mining activities.

?? Using a GIS and a variety of digital maps, the United States Geological Services (USGS) and the Forest Service created perspective views of an area to depict the terrain before and after mining. GIS was used to combine map types and display them in realistic 3D perspective views that conveyed information more effectively and to a wider audience than traditional 2D maps (USGS, 1997).

?? At the University of Nottingham, GIS has been used to aid in the resettlement of villagers in Ghana who live on the site of a new surface mine development. The representation of the resettlement areas allowed assessment by the Ghana Environmental Protection Agency before the project began (Mensa, 1999).

## **9 Simulation**

The formal definition of discrete system simulation is a system where, at any instant in time, a countable number of changes can take place. Trucks being loaded, travelling to a dump, dumping, being refuelled, returning to the mine, etc are classic examples of such systems (Sturgul, 1998).

Sturgul (1998) believes that the most important advance in recent years has been the introduction of animation (visualisation) into simulation software. This shows

the results of simulation in a 2D 'cartoon' fashion. Sturgul justifies this statement with the following two reasons:

?? Often simulation programs can contain insidious errors that do not show up when the program is being run and can be detected best when viewing the animation.

?? Prior to animation, the results of the simulation study were often presented as a set of numbers.

Two such applications relevant to the work in this research, which have benefited from the use of visualisation are described below:

?? Finite Element Analysis (FEA) consists of a computer model of a material or design that is stressed and analysed for specific results (Figure 3-18). For example it is used in new product design, and existing product refinement

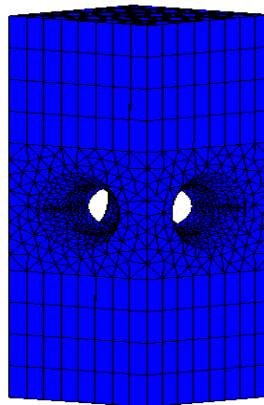

**Figure 3-18: Stress Analysis Model**

Finite Element Analysis (FEA) was first developed in 1943 by R. Courant, who utilised the Ritz method of numerical analysis and minimisation of variational calculus to obtain approximate solutions to vibration systems. By the early 70's, FEA was limited to expensive mainframe computers generally owned by the aeronautics, automotive, defence, and nuclear industries. Since the rapid decline in the cost of computers and the phenomenal increase in computing power, FEA has been developed to an incredible precision. Present day computers are now able to produce accurate results for all kinds of parameters (Monaghan, 2000).

FEA has become a solution to the task of predicting failure due to unknown stresses by showing problem areas in a material and allowing designers to see

all of the theoretical stresses within. This method of product design and testing is far superior to the manufacturing costs which would accrue if each sample was actually built and tested (Monaghan, 2000).

?? Computational Fluid Dynamics (CFD) rests on the foundation of the scientific laws that deal with mass, momentum, and energy. However, the rigorous calculations needed to work out the implications of all these laws overstretches modern computational power, even that of parallel processors. Shortcuts (usually called models) must be used. CFD therefore also rests on the less secure foundation of models of turbulence, radiation, and chemical reaction. The turbulence models now in use derive mainly from research projects performed at Imperial College in London in the 1970s. Additions with respect to combustion have come from the University of Trondheim, Norway (Freeman et al, 1997).

In the process and petroleum industries, CFD can reduce development time scales and costs by replacing lengthy and expensive laboratory investigation with numerical predictions. For example, a quantitative description of the pressure distribution on a sub-sea oil platform (Figure 3-19) as a function of time is useful for optimising design for maximum load and fatigue life.

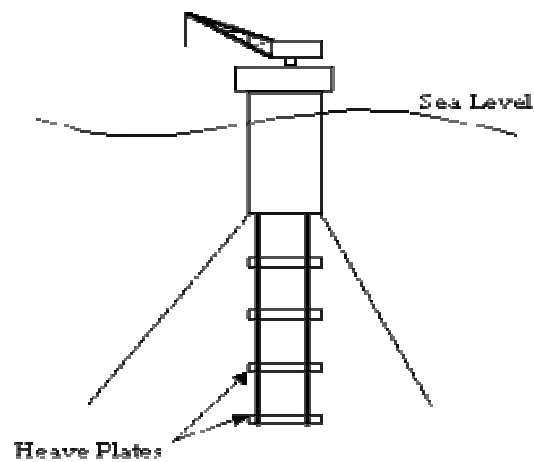

**Figure 3-19: Heave plates**

Figure 3-20 shows a contour plot of the pressures around a submerged heave plate at an instant in time. Visualisation of the flow gives improved understanding of the effects of platform design on performance (ARA, 2001).



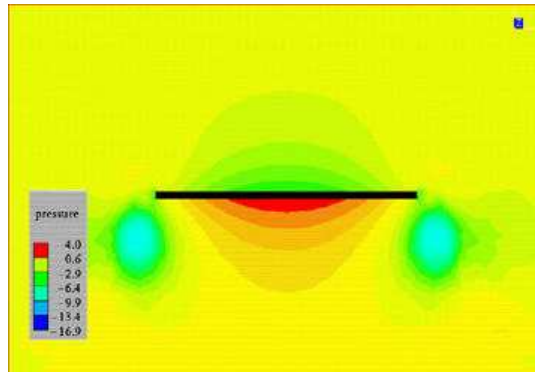

**Figure 3-20: Calculated pressure contours around a submerged heave plate**

The use of CG&V is dependent on hardware, software and the imagination of the users. The military, industry, and entertainment sectors are currently using interactivity within their simulation systems.

Most people associate simulation application or simulators with aircraft training. One such company Evans and Sutherland develops and manufactures hardware and software to produce highly realistic 3D synthetic worlds. It produces high-quality visual systems for simulation and training in defence and commercial applications as well as high-performance systems for digital theatres and other applications throughout the world. Evans and Sutherland sell flight training simulators which replicate in-flight conditions that are crucial to effective pilot training. These simulators represent realistic simulation scenarios including fog, rain, and snow. Pilots are able to virtually experience reality, before they ever leave the ground. An image from a commercial flight training application is shown in figure 3-21 (Nasios, 2001).



**Figure 3-21: Image from a commercial flight training application**

The cost of technology is decreasing and the power of the computers is increasing. The demand for interactivity is pushing computer visualisation to the limits. This technology advancement leads to a discussion of virtual environments.

## Virtual Environments

Youngblut et al, (1996) reviewed Virtual Environment (VE) interface technology from the perspective of the user, that is, the devices and requirements that are imposed on the user in order to interact with a VE. In Youngblut's report the term VE is used synonymously with virtual reality and synthetic environment.

Whilst there is no widely accepted definition of the term VE, the approach chosen is to describe a VE system as a computer-generated world with which the user can interact with the purpose of altering the state of the user (Figure 3-22) or of the computer (Durlach et al, 1995).

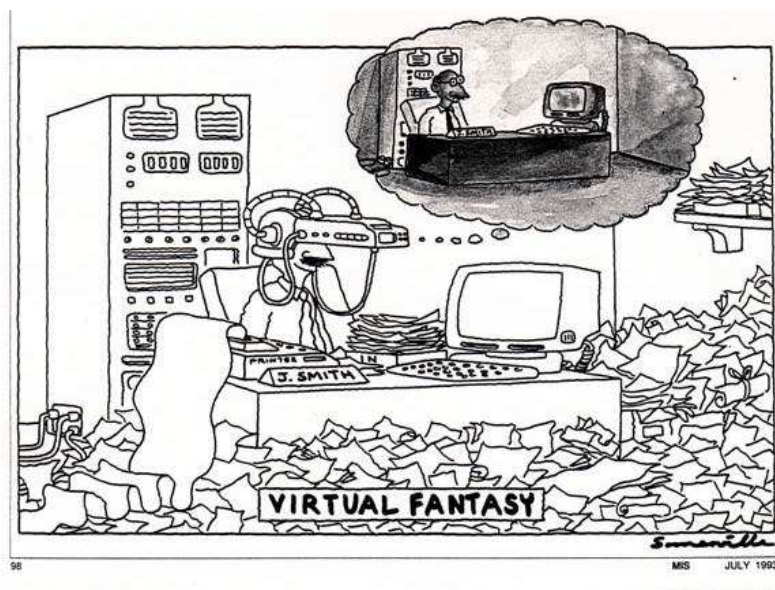

Figure 3-22: Virtual fantasy (Summerville, 1993)

Kolasinski in his report defined a VE as a 3D, interactive, realistic, real-time computer generated simulation providing direct input to the senses via a Head-Mounted Display (HMD), Binocular Omni-Oriented Monitor (BOOM), DataGlove and similar devices. From the standpoint of a user, there are three major components of a VE system. First, the user must have some way of seeing in the virtual environment. This is sometimes accomplished with a HMD. Second, the user must have some way of moving through the VE. Joysticks, spaceballs, and wired clothing devices are some of the current devices used to control

movement in the VE. Finally, there must be some way to identify the user's direction of view in the VE. This is accomplished by means of a tracking device, often attached to the HMD (Kolasinski et al, 1995).

There are two types of VE's:

?? **Immersive** VE systems, where the user is essentially surrounded by the virtual world to the exclusion of the real world. An advanced interface is where the user views the virtual world through a HMD. The HMD presents an image directly in front of each eye and magnifies it so that it fills a wide field of view, creating the impression of actually being in a world, rather than looking at a screen. However, HMD technology is fairly crude, and rather expensive, and has a number of disadvantages including encumbrance, isolating experience and occasional simulator-sickness (Schofield, et al, 2000).

?? **Non-immersive** where the user views the virtual world indirectly through a computer monitor or some other display and, typically, interacts with the VE using more traditional keyboard, mouse, and trackball interfaces. A third alternative is augmented reality systems where the virtual world is superimposed over the real world. Here the intent is to supplement the real world with useful information, for example, guidance in performing a real world task (Youngblut et al, 1996).

The two types of VE systems are scala, for example, the 'true' non-immersive as Youngblut (1996) informs us, uses a computer monitor with traditional peripherals (keyboard and mouse). However as technology improves peripherals become more elaborate, specific and sensitive, allowing motion and force feedback to the user. Although the user is not immersed visually as they are still using a computer monitor to view, they do get a sense of feel. This also applies to immersive, as technology improves the use of HMD's as well a sensor bodysuites will provide the user with 'full' visual and sensory immersion.

### ?? ***Immersive virtual environments***

There is currently considerable focus on VE systems because the potential of these systems is enormous. They offer a more intuitive metaphor for human-computer interaction. The user can exploit their existing cognitive and motor skills for interacting with the world in a range of sensory modalities and, in many

instances, the experience they gain in the VE is directly transferable to the real world (Youngblut et al, 1996).

Examples of VE based training exist in a number of other sectors. Anyone that has flown in a large passenger aircraft has trusted their lives to someone that has been trained with the assistance of a VR system. The techniques that have been developed over a number of decades in this area are now available on the desktop and have been adapted into a whole range of other training applications. These types of system offer major potential advantages due to increased retention caused by the visual nature of the medium and the role-playing nature of the interactivity (Hollands et al, 1999).

Researchers at Brown University in America are developing applications for visualising tensor-valued diffusion-rate volume data (of the brain) acquired with magnetic resonance imaging (DT-MRI) (Figure 3-23). They are making use of CAVE immersion for surgery rehearsal, post-surgery treatment and tracking. (Brown University, 2001).

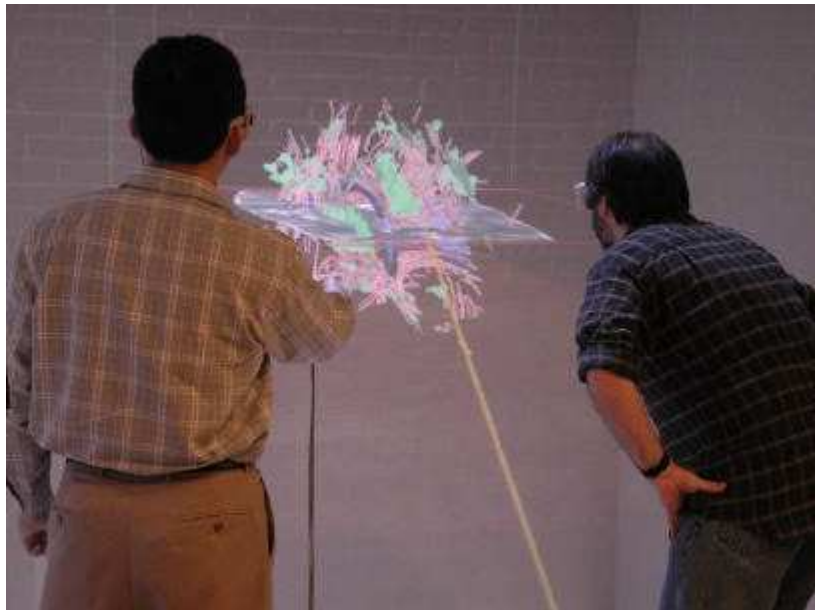
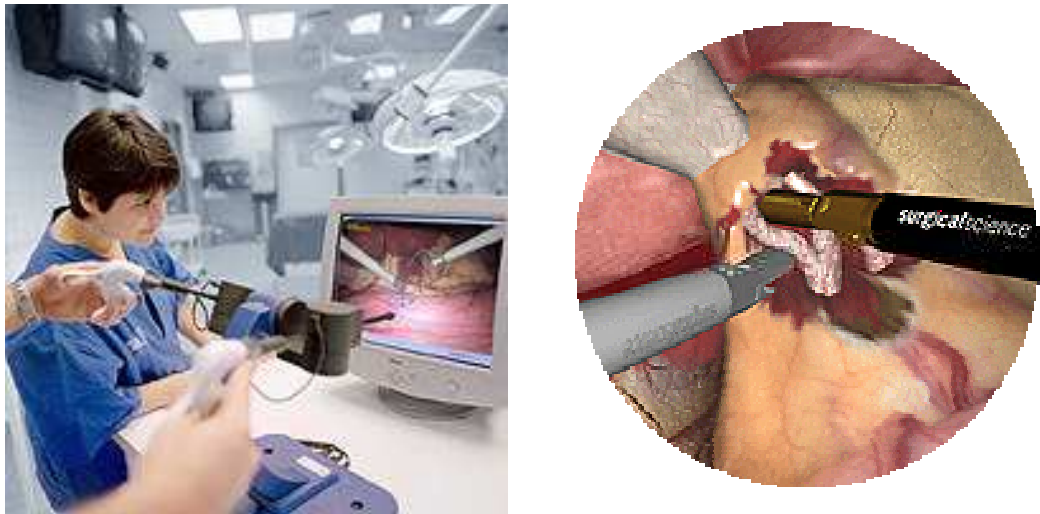

**Figure 3-23: Researchers viewing 3D brain**

### **?? *Non-immersive virtual environments***

The following example is classed by this author as non-immersive as the user is still viewing the object on a standard computer monitor as a 2D model. They are using a peripheral specifically designed to mimic the tool required for this

training. The intent is to provide the user with a meaningful environment within which they can interact in a natural, multi-modal manner. In medical training, a surgeon could practice a particular surgical procedures on a virtual patient, for example; practice basic skills or accurately simulate a critical phase in the frequently performed laparoscopic cholecystectomy procedure (Figure 3-24), the dissection of calot's triangle. Misidentification of bile ducts and blood vessels is a constant risk and simulation aims at reducing the risk by improving the surgeon's skills in a safe, simulated environment (Lapsim, 2002).



**Figure 3-24: Non immersive laparoscopic training**

In addition to visual images, the surgeon's major form of interaction with the system is by means of specially-modified versions of his customary instruments that provide realistic haptic feedback sensations as the surgeon manipulates virtual body tissues (Hunter et al, 1993).

## **Conclusion**

A picture is said to be worth a thousands words and CG&V technology has the capability to express this statement in a modern way. CG&V is commonly understood to mean the creation, storage and manipulation of models and images. Such models come from a diverse and expanding set of fields including physical, mathematical, artistic, biological, and even conceptual (abstract) structures. (Nasios, 2001).

The rapid developments in PC technology in recent years and the huge potential market for desktop VE in a wide range of sectors means that this is the area where some of the fastest developments are occurring. Whilst much of the development is for the leisure industry there are real industrial opportunities that can be exploited. The home computer games market has driven the development of software tools for the creation of 3D models together with the specialist 3D graphics accelerator boards and peripherals for PC games systems (Schofield et al, 2000).

The development of computer generated accident reconstructions culminating in training applications using simple presentations through to full scale simulations using virtual reality provides an ideal platform for educators, occupational health and safety trainers and competency assessors.

Computer generated forensic CG&V will form important admissible evidence in the courtrooms of the future. Acceptance by the public and courts is an important issue, and implementation strategies must be considered carefully.

The following chapter looks at the current use of CG&V in courtrooms both locally and internationally.

# **4 COMPUTER GRAPHICS AND VISUALISATION FOR COURTROOMS**

## **Introduction**

Individuals from engineering and scientific disciplines are frequently required to testify in court on a broad range of topics, such as personal injury, product liability and patent infringement. The issues in question can be extremely complicated and difficult to explain to the court without some form of graphic representation. A survey by the American Bar Association (ABA) found that jurors are often confused, bored, frustrated and/or overwhelmed by technical issues or complex fact patterns. Further research indicates that the attention span of the average juror is seven minutes. This illustrates the need to reduce lengthy explanations with charts and diagrams alone (Goodwin, 2000).

Computer animation is one particular method that helps to communicate complex technical matter to a non-technical audience. Where only static images such as diagrams and charts have previously been used to explain the testimony of an expert witness, computer animations are now also utilised for illustrating the time dimension. This extra dimension is extremely useful when explaining a critical accident sequence, complex vehicle motion, or a complicated engineering principle or theory. Computer animation is also used when taking advantage of its lack of physical restrictions, which allows the viewer to go where it is physically impossible to go with a normal camera (such as inside an engine or a human body), or to show witness views of a crime or crash (Jones et al, 1991).

## **Computer Graphics and Visualisation for Understanding**

Schofield and Noon (1999) believe that the experience of the US courts has demonstrated the overwhelming advantage of using computer-generated evidence to aid understanding among all involved in an accident inquiry. Using forensic animations for investigation evidence can be advantageous for a number of reasons including:

?? an accurate and effective method of showing how an event occurred or could

occur,

?? are believable as the animations are often close to a real life portrayal of the event,

?? investigators and trainees often remember CG images long after other forms of media,

?? computer systems allow investigators to recreate the accident environments; this is useful since the site of an accident may have changed since the time of the event, and

?? a jury can visualise 'hidden' data, e.g. the display of vehicular or projectile trajectories.

The following studies in the USA have shown that the odds of winning a court case dramatically improve when a forensic animation is used:

?? One American study showed that the average person retains 87 percent of information presented visually, but only 10 percent of information presented orally (Seltzer 1990).

?? Another study showed that the average person has 65 percent retention of visual information and only 15 percent for oral information (Cobo, 1990).

?? One American survey showed that juror memory retention increases 100 percent when using a visual presentation over an oral presentation (Krieger, 1992).

?? Another survey revealed that there is a 650 percent increase in jury member memory retention with computer animation presentations (Thomas, 1997).

A series of experiments were conducted at the West Midlands Police Service (UK) Crash Investigation and Training Unit (CITU). Three separate groups were asked to memorise a series of accident information. One group were shown textual descriptions, a second group were shown images and a third group were shown both the text and the images. As was expected the group who saw only text performed the worst with a number of errors. The group who saw the images made very few mistakes and the group shown both text and images performed the best (Doyle, 1999).



In a recent study by Elizabeth Loftus (2001) participants first watched a two minute video clip of a drunk-driving incident on a computer screen. In the video three police officers begin their Saturday night shift at the ferry dock. One of them is seen warning several men not to drive, as they may be drunk. After much discussion about whether to take the train or drive, the men get into the car. The one occupying the front passenger seat is seen looking drunk or asleep.

For half the participants, the scene shifts to another policeman who is standing in the path of the car trying to stop it. After some yelling on the part of the passenger and the police, the car hits the policeman, and he ends up hanging on to the roof of the car. Much chaos ensues, and the video ends with an arrest of the people in the car and attempts to care for the injured policeman.

Participants were then asked to imagine a variety of scenes from the video. The 'imagination' participants were asked to imagine a scene that was not actually presented. Finally after a short four minute filler task, participants were tested on their memory of the video.

In terms of free recall 2 percent of the 'controls' mentioned the false critical detail, compared to 15 percent of the 'imagination' group. A critical recognition question was also asked about the scene that was not presented, 15 percent of the 'controls' recognised this scene as a critical aspect of the event, compared to 41 percent of the 'imagination' group (Loftus, 2001).

The results of this experiment helps demonstrate the power of the visualisation to assist in presenting information and evidence in the following ways:

?? As a precursor for stimulating the imagination. Only 2 percent of the 'control' group mentioned the false critical detail, where as the 'imagination' group that were asked to image a scene that was not there, 15 percent mentioned it as a critical scene. This result, although supporting the view that presenting visual information, people will retain and recall the facts. However, a trial lawyer could use the same presented CG&V to assist their case by playing the same visual but presenting what they believe (their clients view) what happened and to stimulate the imagination of a jury or similar just by adding their own voice over and explanations or in the case of the Loft experiment just image an alternative.

?? Retention of information by showing a visual and providing additional information in the way of speech was proven to be very beneficial. Only 15 percent of the 'control' group recognised a scene as critical where as the 'imagination' group that had this extra information, 41 percent identified it as a critical aspect.

These results obtained by Loftus although not definitive, provides evidence relevant to the research question, *What are the merits and level of acceptance associated with the use of computer visualisation techniques for the reconstruction of incidents/accidents?* It also demonstrates that although a CG&V assists in presenting the facts and people do recall, there is a possibility that in presenting a certain view of CG&V information it may lead to people being instructed to view the CG&V in another way which would possibly negate the initial use of the CG&V by the party who first presented it.

All of the above examples demonstrate that the use of CG&V provides a greater understanding of what is being shown as well as assisting in memory retention of what has been shown. This justifies the use of CG&V for the reconstruction of industrial accidents and for training in a wide range of environments.

## **Legal Uses of CG&V and Relevant Issues**

There is nothing novel or radical about using visual technology for courtroom use. A photograph was first admitted as evidence in the USA in *Church v City of Milwaukee*, (1872)<sup>1</sup>. This case specified that a photograph of the plaintiff's premises could properly be admitted as evidence. New types of visual evidence have repeatedly been introduced. The challenge is to adapt familiar evidentiary precepts to evolving technologies - in other words, to unfamiliar facts (Joseph, 1996).

The defining characteristic of virtual reality evidence, its interactivity, raises unique relevance and prejudice issues, in addition to the fundamental questions typically presented by computer simulation evidence. As technology becomes

---

<sup>1</sup> 31 Wis. 512, 519-520,

more advanced, and the evidence more familiar, judicial receptivity is likely to increase as is the potential usefulness of the evidence (Joseph, 1996).

### ?? **Definitions**

The introduction of computer generated forensic animations into American courts was controversial. People arguing against them said that the animations were based on artistic interpretation rather than factual evidence. People arguing for forensic animations say that they offer the ability to visualise the 'real' data and witness the accident from more than just a bystander's perspective (Cybulski and Valentine, 1998).

There is a concern that many people have an inability, when viewing simulations, to distinguish between fact and fiction, that is, between a computer-based 'reconstruction from first principles' based on physics and engineering laws and a photo-realistic computer-rendered animation based on subjective data (Borsook, 1998).

Ambermind (1999) an Australian company who use CG for showing information to courts inform us that there are essentially two forms of computerised legal animation for use by the legal profession for courtroom usage:

?? **Representation** : this type of animation is a 'dramatisation' of the event. The animation is a guide without focusing on precise details.

?? **Reconstruction** : this type of animation contains extremely precise details, and replicates the exact event as per the existing evidence.

Barbara Mills (1991) in her paper at the Australian National Crimes Authority distinguishes between three types of uses of presentation graphics, irrespective of the technology used to prepare them:

?? **Fact Graphics**: illustrate the most important agreed facts in the case. Examples include time lines indicating the order in which events occurred, or diagrams to explain the structure of a company or an interlocking group of companies.

?? **Concept Graphics**: illustrate concepts with which a judge or jury may not be familiar, without any particular reference to the facts of the case being tried. For example, concepts such as reinsurance, the operation of the futures market, how unit trusts work, 'DNA fingerprinting' or projectile movements could be

the subject of concept graphics. Concept graphics will often require support by expert evidence, and may become contentious if there is expert disagreement concerning the concept.

?? **Case Graphics:** show the basis of the allegation, or of the defence, and are therefore different from fact graphics in that they include disputed facts, and inferences which either side may deduce from the facts that they allege. Such graphics will often be contentious. Possible objections may include claims that inferences are being unfairly presented as facts or that the graphics are presented in such a way as to have emotive connotations.

Irwin (1995) argues that computer generated animation is an extraordinarily powerful tool which combines facts and hypotheses, in the re-enactment of events. Irwin presents the following definitions of presentations to court.

?? **Illustrative purposes:** An accident reconstructionist expert may testify about the manner in which a collision occurred. Given the expert's testimony is admissible, a Computer Graphics and Visual Graphics (CG&VG) presentation would also be admissible to illustrate the expert's opinion, so long as the expert testified that the CG&VG fairly and accurately depicted that which is sought to portray. This type of exhibit supports or summarises testimony or opinion.

?? **Substantive evidence:** is probative in nature, i.e., its presence supports the probability or non-probability of an occurrence. Therefore, substantive evidence requires a more exhaustive foundation for admission. The CG&VG, used as substantive evidence, must accurately represent the accident scene, vehicle motion and the expert's opinion. This evidence is used to educate the court.

Goodwin (2003) before discussing the use of 'computer animations' as evidence in court and its subsequent admissibility provides the following to clarify the terms used to describe such technology.

?? An **animation** is a general term describing - any presentation which consists of a series of graphical images being sequentially displayed, representing objects in different positions from one image to the next, which implies motion (Grimes, 1994). This term may be used to describe a technical, scientific based presentation or a presentation consisting of artist renditions, sometimes referred

to as a 'cartoon animation'.

?? The phrase **scientific animation** is used to describe a more technically based presentation, and is defined as - a computer animation that is based on the laws of physics and appropriate equations of motion (Grimes, 1994). Technically, a scientific animation, used in an accident reconstruction, demonstrates motion with accelerations consistent with Newton's Second Law. Velocities and positions are time integrals of the acceleration data. Objects and environment in a scientific animation are properly and consistently scaled.

?? A **simulation** is a model which predicts an outcome. The model may be a physical or a mathematical model, but the significant property is that a simulation predicts a future result (Grimes, 1994). In the accident reconstruction community, a simulation is based on the laws of physics and contains specific equations of motion.

From these definitions there are similarities, but when dealing with legal issues there is a need to develop definitions that will be applicable to all areas of CG&V reconstructions.

### ?? ***Admissibility***

The collection of data can be extremely varied and it takes considerable skill to collate that data into a narrative for evidence presentation. The usual type of presentation is by the question and answer of witnesses by advocates. It is important to relate certain points to an enquiry panel clearly and succinctly, hoping that they understand all the technical detail that may be described.

As technology advances, analysis of accident data becomes more elaborate and there is a need to provide graphical representations of the incident, scene and events. Forensic animations provide strong visual explanations, but there are many problems with this type of evidence. It could be argued that forensic animations are not computer records, however the animations graphically show details directly related to documentary evidence (calculated values or witness statements for example). The fact that the evidence is often available in another form is a crucial point, forensic animations must be considered as corroborative and supportive, rather than as stand-alone evidence (Fisher, 1999).

The method of presentation of digital data to an enquiry is a matter of some concern. Presentations are often in the form of a multimedia presentation, where different parts can be accessed and used as required. This presentation will usually contain original document scans, text, rendered images and forensic animations (shown on a computer monitor, projection screen or using videotape).

It is important to ensure that, while working on producing digital evidence, data files are secure. All models, images and animations must be protected from external (i.e. network) alteration (Schofield et al, 2000). To ensure that electronic evidence is not altered audit trails are kept and digital evidence are watermarked to ensure that the 'original' digital evidence is submitted without alteration. If there is objection to the digital evidence the court will request that the original item be presented.

### ?? ***Admissibility in Western Australia courts***

One of the first cases to use CG&V in Western Australia was the following case listed at the Perth District Court, *The Queen v Marotta, Bull and King (1995)* and used by the defense council.

Three men faced Judge Mary-Anne Yates in the Perth District Court on 17 June 1997 for allegedly raping a young woman on 18 November 1995. Part of the defense case was a reconstruction of the event using video and CG&V. The video was used to document how the reconstructionist obtained the measurements of the scene. People with similar physical characteristics to the accused and the victim were used to demonstrate the victims testimony (Annear, 2001).

The CG&V presentation (Figure 4-1) were used to further demonstrate, that the victims statement of the incident was impossible to re-enact without changing the crime scene parameters. These parameters included increasing the size of the shower recess to enable two people to occupy it. As shown in the figure 41 for the incident to happen as described by the victim the accused is required to be placed through the shower recess wall (Annear, 2001).

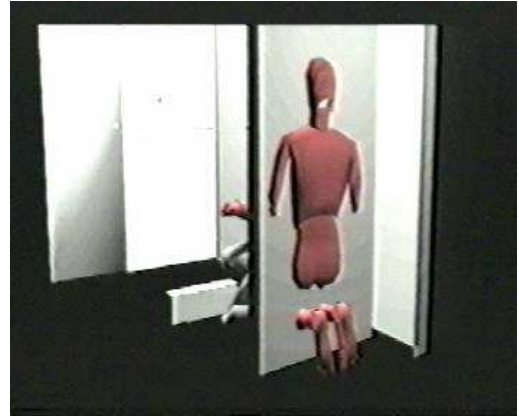
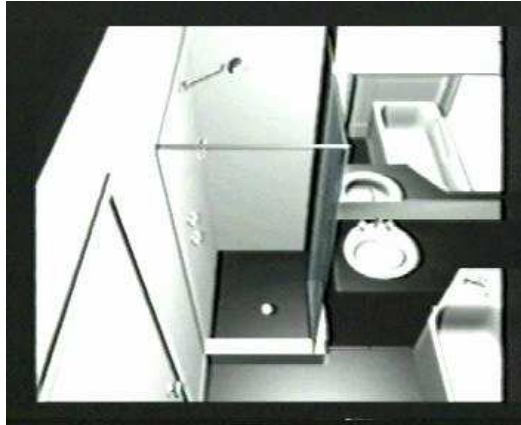

**Figure 4-1: Scene from Marotta case (Courtesy M Annear)**

The trial returned mixed verdicts of guilty on some charges and not guilty on others. On appeal to the High Court of Australia the convictions were set aside.

In the Supreme Court of Western Australia, *Brambles Australia Ltd v Others* (1994) (Appendix 9) saw the introduction of computer simulation (WASC, 1998).

Two road trains collided and the issue of negligence was being sought that included which road train crossed over to the wrong side of the road. The Brambles road train consisted of a Volvo prime-mover with double axle steering towing a single tri-axle tipping semi-trailer. This in turn was towing a bogie axle converter dolly, supporting a further single tri-axle tipping semi-trailer. The other road train consisted of a Volvo prime-mover with single axle steering towing a belly dumper tri-axle trailer. This was towing a converter dolly which formed the front wheels of a further belly dumper tri-axle trailer. The gross weight of each road train was approximately 83 tonnes. Each was approximately 30 metres in length having a maximum overall width of about 2.5 metres (SCWA, 1998).

A computer model was constructed to simulate the collision but it was also acknowledged, that this approach is subject to the limitations of the computer program and the assumptions, on which the simulation was based. These included a perfectly smooth road of infinite width.

The above examples demonstrate that usefulness of CG&V to the WA legal profession in explaining technical issues to lay people.

## ?? **Admissibility in other Australian courts**

The following examples demonstrate that CG&V has been used throughout Australia either as a computer generated simulation/animation or visual using digital photographs and using computer software to join the photos together to create a single computer generated environment ('crime-scene').

### **Victoria**

In October 1994 a CG&V was used to demonstrate flood plans to the Administrative Appeals Tribunal of Victoria, Planning Section. (Appendix 10).

A computer model was developed to demonstrate the behaviour of the floodplain in flood conditions. It is also worth noting the following extract from the transcripts;

*It is true that computer models are inherently uncertain but it is also true that in this case the assessment is conservative because it makes no allowance for the permeability of the under structure of the building, the removal of buildings from the floodplain in association with the development, and the relocation of other buildings into the lee of existing buildings. The Tribunal is satisfied that the impact of the proposed building on floodplains in this location is sufficiently marginal to be disregarded (VICAAT, 1994).*

CG&V was also used in a murder trial *The Queen v Michael Joseph Challoner*. Challoner, was convicted by a jury in the Supreme Court at Melbourne on 23 May, 1996 on one count of murder. The judge sentenced Challoner, on 31 July, 1996, to be imprisoned for 19 years. A non-parole period of 15 years was fixed.

An appeal was granted and lodged - Supreme Court of Victoria, *The Queen v Michael Joseph Challoner* (1996)<sup>2</sup> (Appendix 11), and it was from this documentation that the use of computer graphics used in the original trial is mentioned.

A CG&V presentation was prepared with the intention of producing a reconstruction of the scene, rather than simply a plan. This was in an attempt to

---

<sup>2</sup> *SCV/No-176/1996*



ascertain the likely path of the bullet, which struck the deceased. It was interesting to note that a video used to view the CG&V (Tendered as Exhibit G) failed to play due to technical reasons. The final outcome was the application for leave to appeal against conviction was granted. The conviction was quashed and the sentence imposed set aside and a new trial was held.

In the Supreme Court of Victoria *Toomey v Scolaro and Others*, (1997) (Appendix 12) an anatomist, Mr Donald Meikle, and bio-mechanist, Mr Noel Lythgo, produced a video computer animation and also video taped a number of demonstrations, in a controlled environment, of situations where a subject was subjected to varying forces against bars at 1000 mm and 933.5mm. They also took anthropometric measurements both of the plaintiff and of the claimed scene of the accident (VICSC, 1997).

In 1997 a gas explosion at the Esso Longford Gas Plant resulted in two fatalities and a number of people injured as well as cutting gas supply for two weeks to a majority of Victoria. As a result of this catastrophe the *Longford Royal Commission* (1998) (Appendix 13) was established. The commission was presented with videos of the actual explosions, digital photography, animations and simulations using FEA.

### **New South Wales**

Ambermind an Australian company successfully introduced CG&V into the Administrative Appeals Tribunal (AAT) court room as a legal animation in an architectural dispute in *Pietrzak & Zayler v. City of Stonnington* (1997)<sup>3</sup>.

An animation was used to show to the court, the building as it would look with the modifications in place, demonstrating that the building proposal would not adversely affect the character of the surrounding streetscape and would not be inconsistent with the existing character and appearance of the Urban Conservation Area.

The judgement, on June 25 1997, was held in favour of the client, and the architectural modifications were allowed. The company that produced the CG&V

---

<sup>3</sup> *AAT Appeal 1997/021664*

asked for comments from the Tribunal as to its effectiveness, and received the following reply;

*The Tribunal is greatly assisted by illustrative material which depicts the outcome of a development proposal..... The advantage of using computer driven techniques is to enhance the accuracy of the material admitted in evidence Mr W Bar, Registrar AAT (Ambermind, 1999).*

## Queensland

An Interactive Crime Scene Recording System (ICSRS) has been developed by the Queensland police (Figure 4-2).



**Figure 4-2: Layout of the ICSRS scene showing hotspots and evidence found**

The ICSRS uses digital photographs taken at the crime scene and the software package QuickTime VR to join ('stitch') the photographs creating a panoramic view of the scene. The photographs are usually taken with a digital camera mounted on a tripod with each photograph having 30 percent coverage of the adjoining photo to ensure seamless joins. Once created the user moves around the scene by placing the mouse on the photo and holding the left mouse button down and moving left or right. This will give the user the sense that they are rotating in a circular motion (left or right). To advance forward through the crime scene recognised 'hot spots' are placed in the photograph so that by double clicking the user moves to a new panoramic view. There is a zoom feature to allow the user to zoom in on areas within the photo albeit the quality of the photographs will determine the quality of the zoomed in picture. In the case of ICSRS, accuracy of the image (Figure 4-2) while important, is not legally paramount.

*The idea is not to represent the images as evidence to the court, but rather to give the parties involved an idea of what the scene looks like. Senior Sergeant Adrian Freeman (Nicholls, 1998).*

The Queensland police have so far recorded eighteen crime scenes using the virtual reality system, two of which have been used in the courtrooms. The first was used in 1998 in the Queensland Supreme Court trial of a man accused of murdering a Japanese backpacker in Cairns (Nicholls, 1998).

### ?? **Admissibility overseas**

Forensic animation has been used extensively as a tool in the U.S. and Canada. In fact, various judges (e.g. Judge Wiener U.S.) have publicly stated their approval of animations provided that they are relevant and accurate. Key examples where animations have been used in the USA are:

?? *Robinson v. Missouri Pacific R.R. Co.*, (1994)<sup>4</sup>. Affirming the admission of a computer-generated animation videotape depicting the collision of a car and train.

?? *Rockwell Graphic Systems v. DEV Indus., Inc.*, (1992)<sup>5</sup>. Admitting computer-generated animation comparing two printing presses

?? *Champeau v. Fruehauf Corp*, (1987)<sup>6</sup>. Affirming the admission of a videotape demonstrating the distance and speed estimates of a collision of a tractor-trailer. In Champeau, the videotaped experiment was not a recreation of the accident; rather it was used to demonstrate general principles of physics and to refute a witness's testimony. The videotaped experiment was performed at the scene of the accident.

?? *People v. McHugh*, (1984)<sup>7</sup>. The court notes noted that whether a diagram is hand drawn or mechanically drawn by means of a computer is of no importance. In McHugh, the criminal defendant sought to introduce as evidence a computer re-enactment of a fatal car crash.

---

<sup>4</sup> 16 F.3d 1083, 1087-88 (10<sup>th</sup> Cir. 1994) U.S

<sup>5</sup> No.84 C 6746, 1992 U.S. Dist. LEXIS 17661 (N.D.Ill. Nov 10 1992)

<sup>6</sup> 814 F.2d 1271, 1278 (8<sup>th</sup> Circ. 1987) U.S

<sup>7</sup> 124 Misc.2d 559, 560, 476 N.Y.S.2d 721, 722(Supp. 1984) U.S

The use of forensic animation in the UK is still in its infancy. Computer-generated evidence litigation in the United Kingdom is based upon admissibility and authenticity laws. The Civil Evidence Act 1995 and the Civil Procedure Rules govern admissibility in the UK. Authenticity is a different matter; the laws of evidence and procedural rules still require the development of comprehensible and comprehensive rules dealing with problems of authenticity. This need is enhanced by a lack of computer technology literacy and the overwhelming effect it has on the computer illiterate (Schofield, 1999).

US courtrooms have repeatedly illustrated the beneficial effects of using CG evidence. Although this evidence has only just started appearing in UK courts, relevant case law from the US and other jurisdictions may be referenced for admissibility requirements. This is particularly true for forensic animations, which by American standards are substantive evidence and thus more complex to admit to trial (Goodwin, 2002).

The following are some examples where CG has been used in the UK

?? In the case of *R v Ore*, at Birmingham Crown Court in November 1998, introduced the first forensic animation to a UK criminal trial. PC Michael Doyle of the Crash Investigation and Training Unit (CITU) of the West Midlands Police Service produced the animation. The case involved a collision between two vehicles at a junction; one of the drivers was killed as he pulled out in front of an oncoming vehicle. The view of both drivers was partially obscured by large hedges and walls around the junction (Doyle 1999).

The forensic animation produced showed the view from the perspective of each of the drivers, and also included high angle views overlooking the scene. The movement of the vehicles was accurately modelled based on the calculations performed by PC Doyle. Although the animation provided strong evidence towards the culpability of the surviving driver, he was acquitted of the dangerous driving charge, based on other, uncontested, evidence put forward by the defence (Goodwin, 2002).

?? Another important case concerns an accident that occurred in the West Midlands in 1999. Forensic animations, created by AIMS Research based on police survey data, were used extensively in a Walsall Coroners inquest in

helping to establish the events that lead up to the death of two motorcyclists. The animated reconstructions visualised how the two motorcyclists were killed, when both collided with a vehicle that pulled across their path (Goodwin, 2002).

In Spain computer graphics is also being used where for example in the case of *Ciudad de Salamanca v Stolt Avenir* two ships collided. The judge rejected the three expert witness's testimony that the Stolt Avenir was to blame. An appeal was lodged and a computer graphic presentation was produced to explain the manoeuvres of the ships. The three appeal judges overturned the original verdict (de Ros, 1999).

### ?? **When to use**

A defence lawyer in a particular trial in the USA argued against allowing CG&V to be used in the trial because it would lead the jurors to believe that this was a movie of what actually happened. The judge stated that the jurors were not likely to be overly influenced by the 'realism' of it as it was quite obvious that it was simply a model and that the simple shapes and lack of detail where detail was not required made it very clear what it was (Applied Kinematics, 1998).

The ultimate question that must be answered is whether the computer generated evidence helps people to understand what happened more clearly than can be achieved by other means. If so, is it so persuasive and realistic as to create a potential for undue prejudice or confusion that is not present with photographs or sound recordings, and does this potential outweigh the probative value of the computer generated evidence?

CG&V is one particular method that helps to communicate complex technical matters to a non-technical audience. Where only static images such as diagrams and charts have previously been used to explain the testimony of an expert witness, computer animations are now also utilised for illustrating the time dimension. This extra dimension is extremely useful when explaining a critical accident sequence, complex vehicle motion, or a complicated engineering principle or theory. Computer animation is also used when taking advantage of its lack of physical restrictions, which allows the viewer to go where it is physically

impossible to go with a normal camera (such as inside an engine or a human body), or to show witness views of a crime or crash (Jones et al, 1991).

Goodwin (2000) states that there are three main perceived benefits to using CG&V displays in the courtroom.

?? Firstly, they aid the understanding of both jury and judge, as they provide an effective means of conveying evidence. As the complexity of the issues presented to a jury increases, the amount of interest, comprehension, and retention will decrease

?? The second perceived benefit is that CG&V displays can be tools of jury persuasion. According to research, people are twice as likely to be persuaded if the arguments are supported by visual aids (Lederer and Solomon, 1997).

?? The third benefit is that CG&V displays provide the presenter with a better illustration of their arguments. Evidence can be retrieved instantaneously during a presentation, and the display can be manipulated for better vantage points (for example, an animation can be zoomed or possibly seen from another view).

Despite the apparent benefits, Goodwin (2000) also indicates that CG&V displays may be misused in court, and the consequences of this cannot be underestimated. The persuasive power of CG&V displays is also their greatest disadvantage; they leave a strong impression on jurors, they tend to mesmerise, and they relax an individuals' natural critical nature.

## **Conclusion**

Australian CG&V evidence litigation is not as clearly laid out as that for the US, or even the UK. On researching State and Federal evidence Acts, it was discovered that most laws were passed nearly thirty years ago, and some even a hundred years ago. A uniform Evidence Act was enacted five years ago to remove the current obstacles for admitting electronic evidence. Not all Australian jurisdictions have adopted this Act yet, but it is important that they do. Nevertheless, the same admissibility issues of hearsay, relevance, authenticity, and opinion evidence still apply, as they do in America and the UK, although most laws relate to stored digital data rather than to computer-generated displays.

One promising step taken by all Australian jurisdictions is the modification of hearsay rules to enhance admissibility of computer evidence. However, approaches taken to determine the admissibility of computer-generated evidence in Australia are not uniform (Goodwin, 2003).

Inevitably the future will be digital technology: digital cameras and videos, electronic document storage, network commerce, internet business, intelligent search agents, computer animations and virtual simulators are already in use. Computer technology in everyday society has altered the fundamental way that certain parts of day-to-day tasks are performed. As computers become more powerful, users redefine their problems to maximise the capabilities of the technology. In any accident investigation inquiry the outcome from the investigation team is often a complex affair. There is frequently a problem in transferring this complex information to both the experts and members of the public. CG&V allows information to be presented in trials, industrial hearings, public inquiries and settlement claims evaluation in an accessible and easily understood visual manner (Schofield, 2000b).

Computer generated forensic animations will form important admissible evidence in the courtrooms of the future. Acceptance by the public and courts is an important issue, and implementation strategies must be considered carefully.

This chapter has demonstrated that the courts are starting to accept CG&V in many forms to assist in explaining evidence presented, however there is still limited use of computer generated evidence to assist in mining accidents and incidents. The following chapter looks at the use of CG&V technology in the minerals and energy sectors demonstrating that there is a natural progression in using CG&V to assist in developing accident and incident reconstructions leading to training application for educational outcomes.

## 5 TECHNOLOGY IN THE MINERALS AND ENERGY SECTORS

### Introduction

The use of specialised software to assist the minerals and energy sector is not new and the following demonstrates some of the most commonly used technology and the purpose it is being used for. The one thing that all of this technology have in common – is visualisation. These can be either drawings or photographs as well as 2D/3D, animation or simulation.

#### ?? *For investigation*

Animation and Simulation can be useful in finding out why an incident happened not specifically to locate ‘blame’ but to discover why structures or systems fail fail. The following example demonstrates the use of CAD and simulation software. In this example, simulation software was used to reconstruct the following incident;

*An operator was killed on 24 July 1996, when the main forestays, which support the boom of a bucketwheel reclaimer (Figure 5-1) crushed the operator’s cabin, following a buckling overstress in the main mast (DME, 1998).*

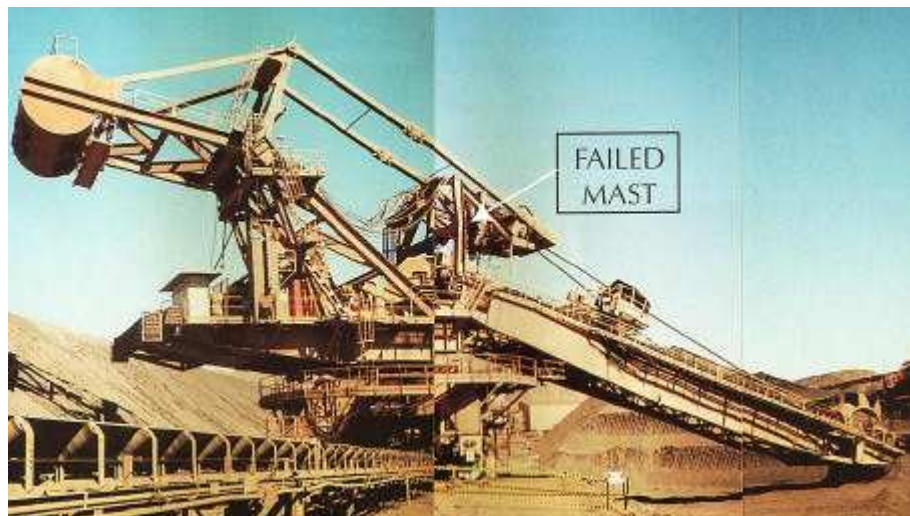
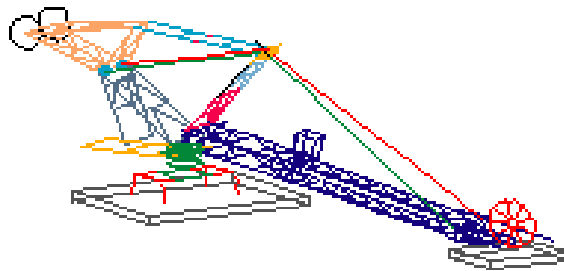

**Figure 5-1: Reclaimer after the collapse (DME, 1996)**



The main jib of a 820 tonnes bucket wheel reclaimer collapsed resulting in a fatality and serious mechanical damage. The bucket wheel reclaimer in question was capable of moving approximately 6000 tonnes per hour (SYDAC, 2001).

Geometric and mass distribution data was provided to SYDAC in a standard CAD exchange format. This data was imported into ADAMS? simulation software to create the basic geometry to which joint and constraint conditions were added (Figure 5-2).



**Figure 5-2: Model in its initial state**

Comparing independent results from a finite element analysis of the structure with the results of the initial static analysis validated the model. The comparisons of the simulated and final collapsed states (Figure 5-3) provided evidence that identified the correct failure mode (SYDAC, 2001).

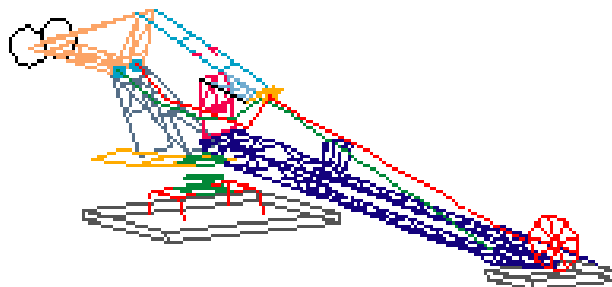

**Figure 5-3: Model in the collapsed state**

The simulation of the collapse proved to be a valuable tool in understanding the failure of this complex piece of equipment. The ability to look at many alternative

load and structural conditions produced a detailed understanding of the system dynamics of interest, safely and cost effectively (SYDAC, 2001).

It is not known whether the SYDAC reconstruction was used in the courts or used only for internal company usage, however the investigation by the Department of Industry and Resources, Mining Operations Division lead to the following action:

*The Department prosecuted Hamersley Iron Pty Ltd, over the death of the plant operator at the Tom Price (WA) iron ore minesite. Hamersley Iron was found guilty under Section 9.1 (a) of the Mines Safety and Inspection Act 1994 for failing to provide a safe plant. In the Perth Court of Petty Sessions on 26 February 1998, the Magistrate (Richard Bromfield) returned a guilty verdict after a four day trial and fined the company \$40,000 plus \$10,000 cost (DME, 1998).*

### ?? **For planning**

A range of mining software is used to assist mining and exploration companies with designing, running and maintaining their environments. Mine planning software began in the large mining companies who developed in-house software during the 1960's and 1970's to help with the planning of large open-pit mining projects. In the 1980's most of the present mining related CAD companies were formed which include such companies as KRJA/Maptek, Datamine, Mincom, Minemap and Surpac (Figure 5-4).

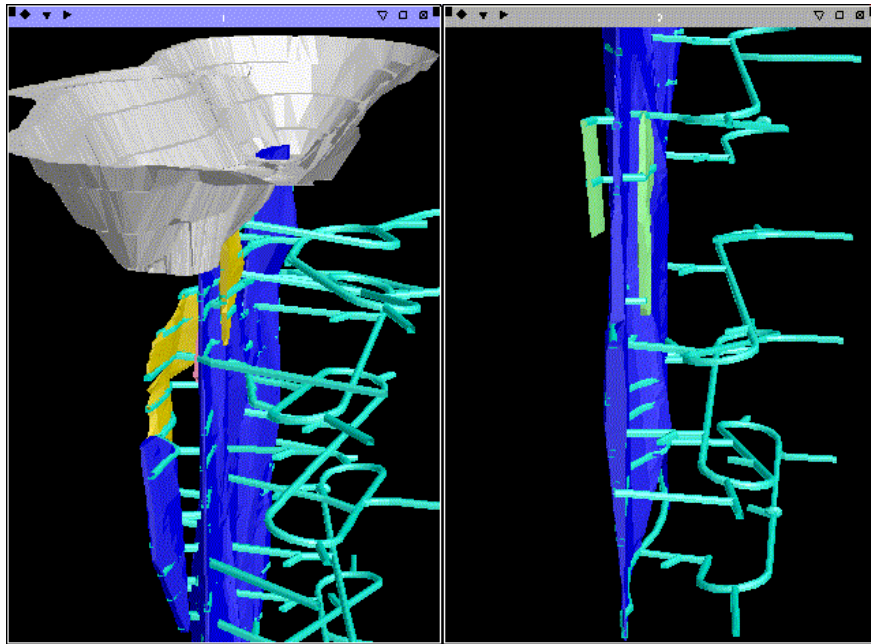
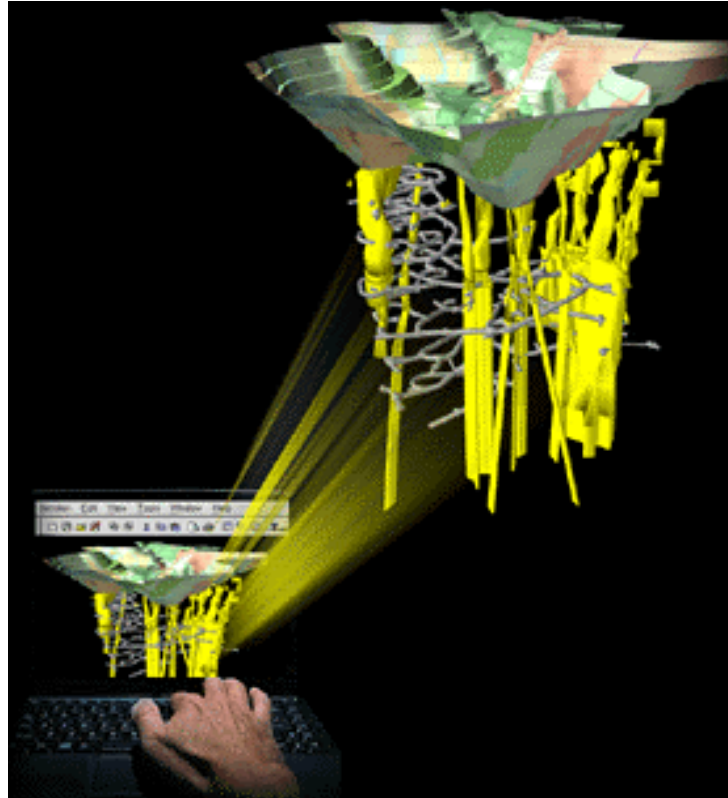

**Figure 5-4: Mine planning (Surpac, 2001)**

The development of mining software can be viewed as a succession of technological advances. Initially, orebody modelling and ultimate pit design were the only objectives. The availability of graphics workstations in the early 1980's meant that variable sized block models and interactive graphical pit design applications became available (Denby and Schofield, 1999).

Originally available for large Unix workstations, most mining software is now being designed to run on 'off the shelf' windows based , personal computers. Modern mining software suites provide advanced 3D spatial information, modelling, visualisation and analysis systems for the mining industry covering: exploration, geological modelling, mine design and planning, mine production, scheduling and surveying, resource extraction, geostatistics, groundwater modelling and rehabilitation (Denby, 1999).

Western Australian companies such as Surpac and Fractal Graphics (Figure 5-5) are developing advanced analysis software for geophysical potential field data which provides information using multimedia and other graphical visualisation tools and methods.



**Figure 5-5: Mine design (Fractal Graphics, 2001)**

Another application specifically for the underground mining is the use of ventilation software. This software can be useful for not only planning purposes but also provide ‘what if’ scenarios.

The extraction of gases (Figure 5-6) and provision of fresh air to miners is very important and if not done correctly can have devastating results.



**Figure 5-6: Diesel fumes upcasting a ventilation shaft**

To ensure that air is circulated through the ventilation system requires large fans (Figure 5-7) that either push air in or extract air from the underground mine. Some fans are reversible so that they can work in ‘either’ mode.



**Figure 5-7: A main mine fan**

The following is a brief description of one of many ventilation packages available. VnetPC (Figure 5-8) is a Windows based program designed to assist in the planning of underground ventilation layouts (MVS, 2001).

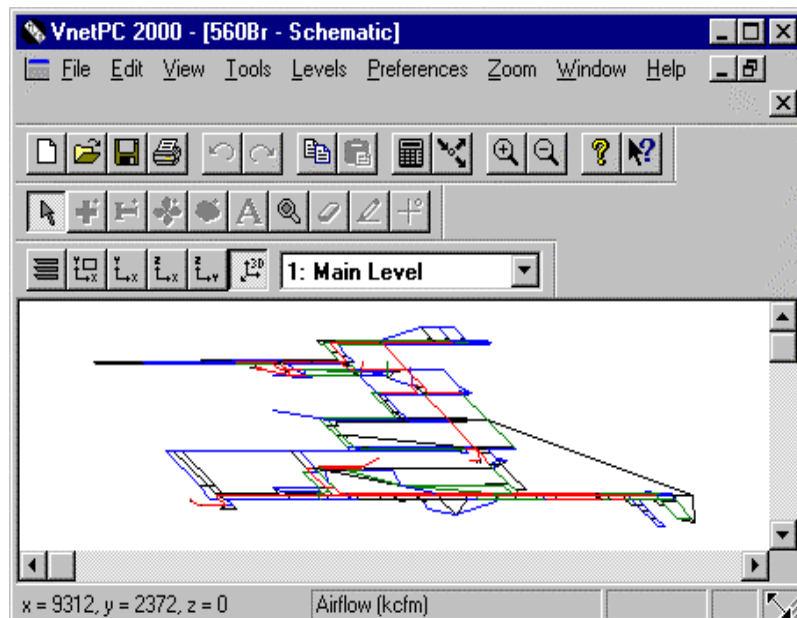

**Figure 5-8: VnetPC2000 screen capture of a mine ventilation system**

The software can simulate existing ventilation networks such that fan operating points, airflow quantities, and frictional pressure drops approximate those of the

actual system. This is accomplished using data from ventilation surveys together with information determined from known airway dimensions and their characteristics. Proposed subsurface facilities may also be designed (Figure 5-9) (MVS, 2001).

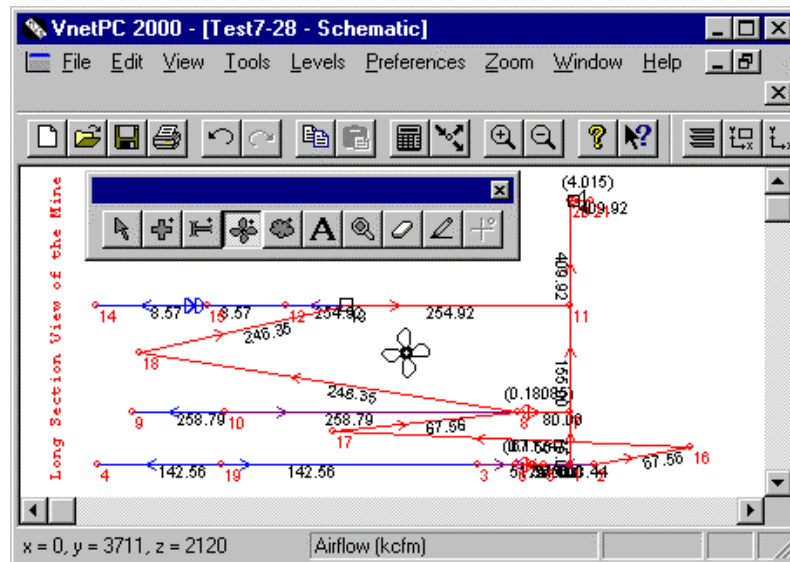

Figure 5-9: VnetPC 2000 screen capture of airflow quantities and direction

### ?? **For training**

There are many examples of CG&V training applications that have been developed specifically for the minerals and energy sectors. Most of these are videos and CBT packages that have a mixture of text, graphics, videos and some have interactivity.

One benefit of computer graphics is that it provides information that is less likely to be misunderstood due to inappropriate words or text being presented and/or the inability to provide instructions due to safety and expense issues.

The following examples typify the use of videos and CG&V packages in the training of personnel in the Western Australian minerals and energy sector.

### **Video**

Recently Central TAFE's Computer Graphics and Visualisation Centre was asked to develop an application that would assist BORAL Industry to train its employees in 'stepping down' or 'climbing up' ladders, equipment and vehicles (Figure 5-10). This is a very common injury throughout the industry and they wanted



something different, as training videos explaining ascending and descending (3-Point-Contact) methods already exist.

The video produced was different to others as it used CG&V (Figure 5-10) to demonstrate how ankles and knees can be damaged by not adhering to the 3-point contact rules when mounting and dismounting vehicles, and how surgery is performed to correct injuries, but still with the possibility of leaving the person with future debilitating problems.



**Figure 5-10: 3-Point contact (courtesy A Bruz and M Annear)**

A video was identified as the best option by the users as the information was to be used as part of the company's induction course. It should be mentioned that it is not common to have PC's at remote minesites and with workers doing 10-12 hour shifts on a fly-in/fly-out basis, training sessions of length are not usually conducted. The video delivers its message quickly and addresses the problem and provides training in this specific area.

## **10 Computer Based Training**

Computer Based Training (CBT) can be delivered on CD-ROM or be distributed over the Internet or on an intranet. Most CBT training has the following characteristics:

?? Interactive: Students interact with the training application and can receive immediate feedback.

?? Multimedia: Multiple forms of media are used: text, sound, graphics, and video help keep the student's attention.

?? Self-paced: Each student proceeds at their own pace. Proficient learners do not

have to wait for others, they progress through the topic/course and some application provide self assessment (tests) throughout of the lesson or course and will not allow the student to progress to the next section until a satisfactory result has been achieved..

CBT can reduce the training time of traditional Instructor-Led Training (ILT) from 20 percent to 80 percent, with most reductions averaging between 40 percent and 60 percent. In one example, Intel replaced an 8 to 12 hour classroom training with embedded training built into a performance support system application that took 1 to 2 hours (over a 5 times reduction). The students' ability to use the software accurately improved from 78 percent to 98 percent. Though this example seems extreme, it does show the potential for reducing training time (Horizon Interactive, 2001).

#### **Immersive/Simulator**

A Western Australian company Immersive Technologies has developed a Haul Truck simulator. In principle it is similar to the simulators that airline pilots use for training. The haul truck simulator has all the characteristics of a 'real' truck. From figure 5-11 it can be seen that the drivers seat, control panel and mechanism are real and the environment (minesite) is projected to all areas that the driver would be able to see from their position inside the haul trucks cabin. This provides the trainee with the opportunity to drive a haul truck in a simulated environment before operating a real one.



**Figure 5-11: Inside the haul truck simulator cabin**



This simulator uses existing CAD data and imports the information to configure the minesite environment and haul roads (Figure 5-12). The various interior truck components can be altered to recreate the type of haul truck the minesite is using.

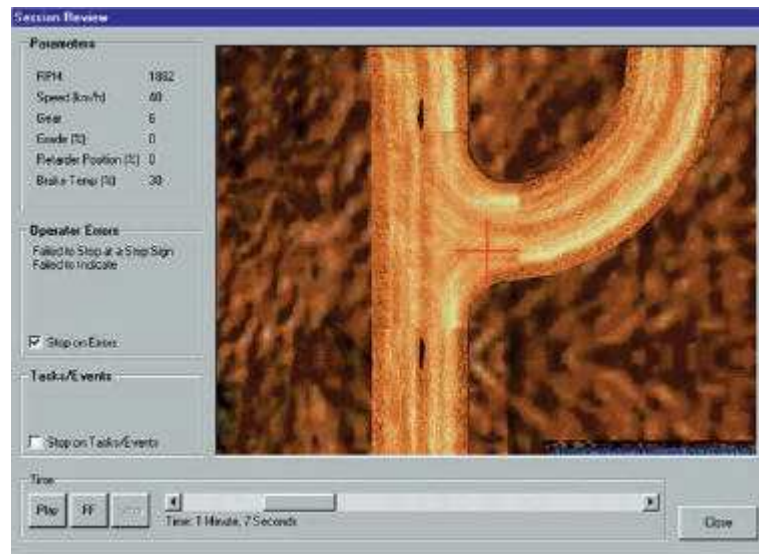

**Figure 5-12: Screen capture of simulated haul road system**

From the moment the simulator starts, the trainee's performance and the machine's vital truck operating information are monitored with the results available in report form for analysis. The supervisor can then 'playback' the simulation and discuss the trainee's actions (Immersive Technologies, n.d.)

The simulator has been designed to:

- ?? Create an environment as close as possible to the real minesite.
- ?? Teach an operator the correct control procedures from safety, production and machine wear and tear perspectives.
- ?? Expose the operator to various simulated events. Many of these would be either too dangerous or difficult to test for real.
- ?? Record the operator's reactions together with the machines vital operating information.
- ?? Provide print outs of a trainees performance.

With the cost of this system starting from \$350k, a number of local and international mining companies have purchased a site specific simulator to assist with their training of haul truck drivers. The cost of putting a trainee driver into a

simulator than using a production vehicle that costs over \$1million is seen to be cost effective.

The AIMS Research Unit at the University of Nottingham (UK) has over ten years experience of creating a variety of VR training aids, and it has become apparent that a large number of VR training applications share a common set of requirements:

?? Generate a 3D representation of a working environment.

?? Place representations of hazardous objects or situations within the virtual world.

?? Allow the user to find, identify and categorise any hazards present.

?? Simulate the operation and dynamics of vehicles, equipment and objects within the virtual world.

?? Allow the user to carry out actions within the virtual world.

?? Tag or report any actions that result in a hazardous situation.

In order to be able to develop such applications without the programming skills normally required, AIMS Research, has developed SAFE-VR, which is a Graphical User Interface (GUI) applications development tool.

One of the primary groups that can benefit from VR based training are those who may have problems with existing training programs due to limitations of language or literacy. Since it is highly unlikely that these users would be significantly computer-literate, any user interface has to be kept simple, so that its operation does not prove to be barrier to learning from the training package (Schofield et al, 1997).

Navigation around the virtual world can be by a number of different input devices. Three-dimensional controllers, such as forceballs, provide the most control over movement but need significant practice to use successfully. For users new to virtual worlds, traditional controllers such as 2-axis joysticks, can be relatively easy to use (Squelch, 1998). For actually selecting objects within the virtual scene, a mouse and cursor may be used. However, learning to use a mouse can be difficult for those persons new to computers. A touch-screen is more user friendly and allows the user to select an object simply by pointing at it.

Each object or hazard in the virtual world can have a number of information files associated with it. These can be any external files recognised by the computer, and are typically multimedia training material such as, text files, video and even web-based resources. For any hazard present within a session, the user can view its associated information files from within the session report (Figure 5-13). Where existing training material exists within an organisation, this can be incorporated into a SAFE-VR training package, and acts as a valuable context-sensitive revision aid.

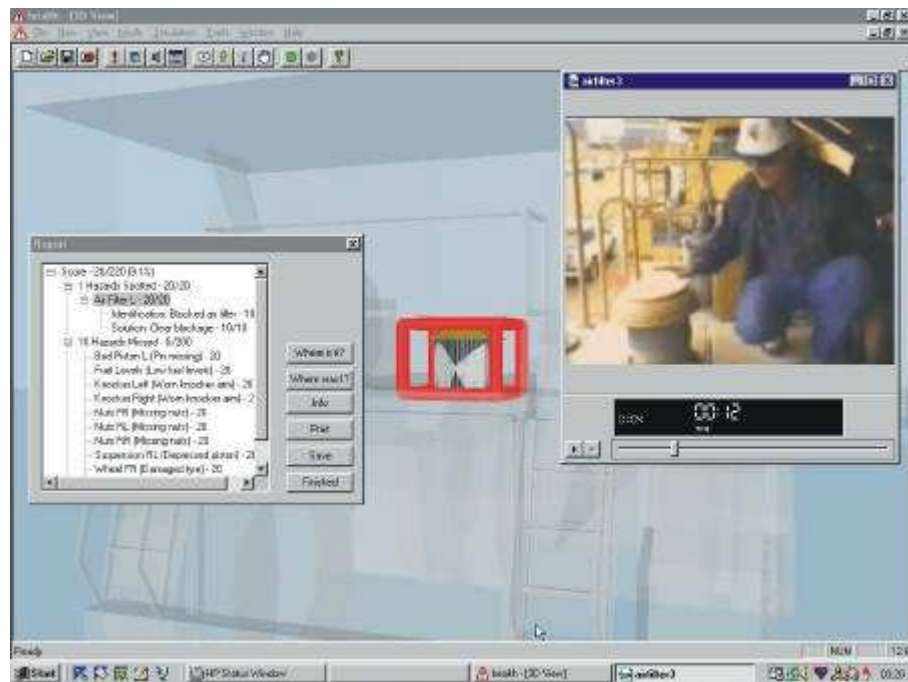
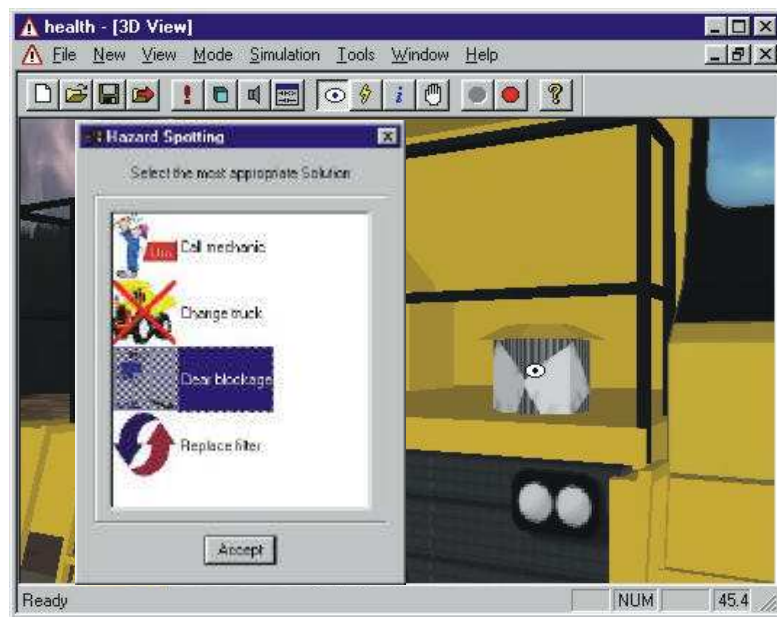

**Figure 5-13: SAFE-VR - Video file activated**

In addition to simple hazard spotting, SAFE-VR also has a method for creating simulations of dynamics, procedural operations and fault tree diagnosis. The fundamental approach taken is that of ladder logic, commonly used in Programmable-Logic-Controllers (PLCs). Any object can have a number of possible actions associated with it and these actions can initiate events within the SAFE-VR simulation. A combination of these various element states can be used for fault-tree based hazard modelling, and because of its basis in industrial controllers it also provides an ideal approach to modelling equipment operation (Schofield et al, 1997).

For example, drivers of large off-road haulage vehicles must understand the importance of pre-shift inspections. These inspections are a pure hazard spotting

application, ideal for SAFE-VR training, which allow drivers to increase their safety through the elimination of potentially dangerous activities. The virtual world created in SAFE-VR allows the drivers to discover a changing variety of hazards, not only the ones identified in this particular accident scenario. The system also explains the consequences, which can occur due to ignoring any particular hazard using the multi-media\forensic animation system (Figure 5-14). In this manner the transfer of complex information to the driver is optimised, and their understanding increased.



**Figure 5-14: SAFE-VR, multimedia selection**

The National Institute of Occupational Health and Safety (NIOSH), a United States of America Government Agency is also investigating and developing applications of VR and other interactive instructional technologies for providing training material in a form that can be more readily measured. The Virtual Reality Mine Safety Trainer (VRMST) is one such application (Figure 5-15).

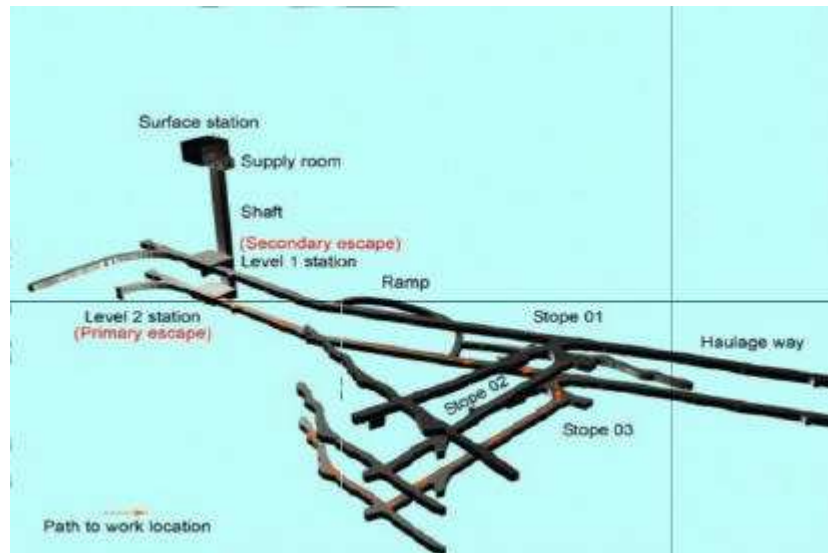

**Figure 5-15: VRMST – VR mine plan**

The software developed at the NIOSH Spokane Research Laboratory (SRL) simulates training environments to increase worker safety by allowing workers to practice basic job skills in many hazardous conditions, such as low visibility, unstable ground, or working near mobile equipment. In addition, the results of bad choices and incorrect decisions can be illustrated graphically without actually exposing trainees to danger (Figure 5-16 & 17).



**Figure 5-16: VRMST – before going underground**



**Figure 5-17: VRMST – underground environment**

The VRMST software also provides network capabilities, which allow trainees located at different computers to work as a team in hazard recognition and evacuation exercises. The software can be installed on a mid-range personal computer. The inherent flexibility of this type of simulator allows easy and rapid updating and modification of the training material. The software could be distributed via the Internet, which will allow end-users to receive frequent software updates, share user-created scenarios, and participate in on-line, multi-user training (Orr and Varley 2000).

### ?? **For research**

The Commonwealth Scientific Industry Research Organisation (CSIRO) is researching the use of 3D visualisation. This involves the development of techniques to integrate complex disparate 3D and time-based data sets by using reliable off-the-shelf software to reduce project development time and use of Internet technologies for the delivery and security of information. They have developed a Virtual Mine (Figure 5-18) model that incorporates an interactive Web based visualisation system using Java and VRML (Virtual Reality Modelling Language) (LeBlanc-Smith, 2000).



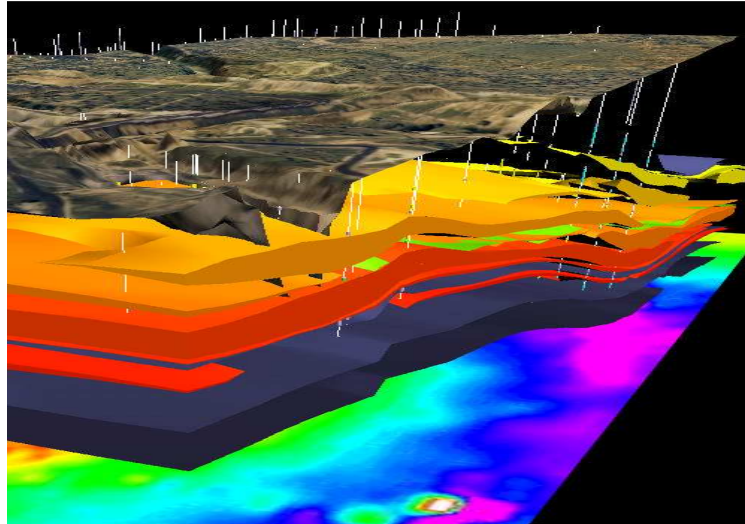

**Figure 5-18: Virtual Mine**

LeBlanc-Smith, (2000) identified the following the benefits of such a system to industry has been:

?? It provides visual integration of disparate 3D data using Internet technologies makes it possible for a mining organisation to better interpret exploration, mining and operational data.

?? It adds value to existing data.

?? It provides an interactive environment that connects visual data sets to other information contained in external databases.

?? It allows the use of an organisation's internal Internet based communication system to provide access to 3D data for various mining operations, particularly remote sites.

?? The integrated 3D models can be developed and updated from a central site and then securely distributed or served to other sites via the Internet.

?? It allows the use of low cost and familiar Windows PC/Web browser environment.

The advancements in 'bandwidth' to send data and the ability of low cost PC's to receive large amounts of data and process that information to present a complete visual scene is getting closer. Some companies are able to do such things but at a cost and the information is usually sent internally. As CSIRO continues to

advance their product so will the information carriers and PC manufacturers develop lower cost products.

## **Conclusion**

CG&V software and other forms of visualisation are used daily by the minerals and energy sectors. They are primarily used for predicting, planning and demonstrating, situations related to geological interpretation and for mining and processing operations.

The following chapters continues to focus on the use of CG&V by presenting reconstructions of accidents/incidents to get information out to the community and the workplaces, to show what happened and how not to repeat mistakes.

The development of computer generated accident reconstructions culminating in training applications using simple PowerPoint presentations through to full scale simulations using virtual reality provides an ideal platform for educators, OH&S and training assessors with additional tools to get their message and information across.



## 6 CASE STUDY 1 – UNDERGROUND FIRE DISASTER

### Introduction

The significant number of underground fires primarily relating to vehicles is a concern to the DoIR. A fire in an underground mine can present a major hazard and threatens the lives of all persons below ground; yet the number of such incidents occurring below ground in WA continues to rise as shown in figure 6-1 (DME, 2000).

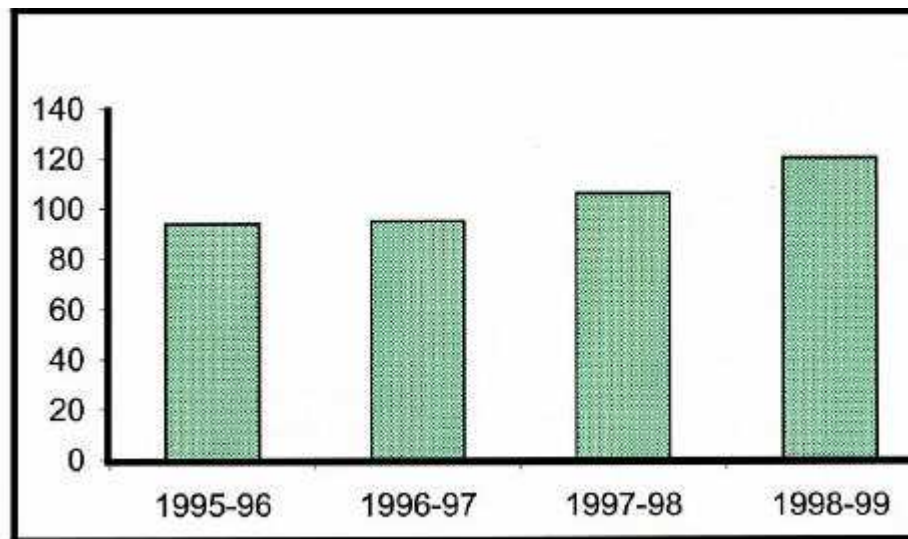

Figure 6-1: U/G mobile equipment fires

In the DoIR publication Minesafe (DME, 2000) an analysis of the four hundred and fifteen underground mobile equipment fires reported in the years 1995-1999 indicate the following categories of responsibility:

?? 47 percent originate in the vehicle engine compartments, and are largely caused by fuel or oil leaks spraying onto hot parts such as turbo-chargers and exhaust manifolds.

?? 27 percent are caused by electrical defects due to wiring short circuits and overload conditions. Batteries, starter motors and the unprotected heavy duty cabling are other major contributors.

?? 13 percent of fires are due to braking systems and primarily involve parking

brakes not fully released. Front brakes cause more fires than rear.

?? 3 percent of fires are caused by the retarder.

?? 10 percent of fires could not be categorised due to inadequate information.

Although no fatalities or major incidences have occurred due to mine fires in WA, other disasters have occurred, with significant loss of lives elsewhere:

?? In 1912 an underground fire in Mount Lyell Mine in Tasmania, Australia claimed 42 lives.

?? In May 1972 a fire in the underground Sunshine Mine at Kellog, Idaho in the USA killed 91 men. The fire was not completely extinguished and the mine reopened in December 1972.

?? In 1986, 177 miners perished in a fire at South African Kinross gold mine.

The DoIR wishes to get a message across to industry that underground fires are a cause of concern. In 1999, the WA State Mining Engineer, Mr J Torlach wrote the following:

*.. throughout the nineties the DME has issued a series of alerts on fire hazards together with summaries of reported incidents. A recent review of reported incidents over a 6 to 7 month period showed that some 300 surface fires and over 80 underground fires had occurred. Whereas fires on the surface regularly result in substantial property loss and damage to plant, particularly mobile plant as shown in figure 6-2, where the potential for a large loss of life is normally much less than for underground fires (Torlach, 1999).*



**Figure 6-2: An underground truck fire**

## **Underground Fire Reports and Information**

To ensure that the industry is aware of hazardous situations, accidents and relevant OH&S information, the DoIR releases various magazines (Appendix 7), reports and data-sheets from its Mining Operations Division. The information presented by the DoIR in such publications relate solely to the incident, without including identifying information.

The following reports are similar (without the departmental header and logos) to those sent to all the minesites in WA and are available from the DoIR website (EXIS, 2001) relating to some of the underground fires that have been reported. It demonstrates that the problem exists and fires can start very easily.

### **?? Significant Incident Reports (SIRs)**

Significant Incident Report No: 23, June 1991

Subject: UNDERGROUND FIRES

*In the space of two weeks underground fires occurred at two separate mines. In incident number 1, a 1.5m<sup>3</sup> load haul dump (LHD) unit rolled onto its side while dumping heavy ore into a stockpile from a one in nine gradient. The stockpile was near full and the unit was partially articulated across the grade of the decline. Two miners were trapped by the fire and were rescued by a Mine Rescue Team. In incident number 2, an LHD unit*

*(of the same type) rolled onto its side whilst attempting to dislodge oxidised ore in a stope.*

Significant Incident Report No: 98, September 1998

*Subject: JUMBO DRILLING RIG - UNDERGROUND FIRE*

*A twin-boom development jumbo drilling rig caught fire in an underground metalliferous mine and was extensively damaged. The fire required the evacuation of all personnel from the underground workings.*

?? **Incidents Reports (Irs)**

Incident Number: 391, February 2000

*Type of Accident: Outbreak of Underground Fire (with injury)*

*The driver of a Toro 35D truck suffered smoke inhalation when a fire occurred on the starter motor underground. He also inhaled some of the dry chemical from the extinguisher he used to douse the blaze*

Incident Number: 497, March 2001

*Type of Accident: Outbreak of Underground Fire (no injury)*

*The operator of a Toro LHD noticed a fire in the engine compartment as he was tramming up the decline. He reversed the vehicle into a level and unsuccessfully attempted to extinguish the fire using the portable extinguishers. Eventually he extinguished the flame by detaching the exhaust lagging and submerging it in a pool of water. The lagging had been soaked with diesel from a leaking fitting.*

?? **Safety bulletin**

Safety Bulletin No: 10, July 1994

*Subject: Fires on 4 x 4 Light Vehicles*

*Details: Within a two-month period two underground fires on Toyota 4 x 4 Land Cruisers were reported. In each case the fire was caused by the engine being driven backwards, as the vehicle rolled back after stalling on an incline, while still in forward gear. This caused the airfilter to ignite due to the combustion cycle being reversed.*

From the information presented to date, it is apparent that the WA mining industry is very fortunate that a major underground fire has not yet occurred. From the analysis of the fire reports from 1995-1999 a majority of these were not due to human errors, but the indications were that there are problems with the machinery. The industry needs to be continually made aware of the potential hazard of underground fires and the need for all mining equipment to be inspected prior to its use and any problems reported.

One initiative taken by the mining industry is to hold fire rescue competitions. Competitions are run at individual minesites, as well as local, regional and at state level. This is not only to simulate real scenarios (Figure 6-3) but it is a method of keeping fire crews prepared and mining personnel mindful and aware of such emergencies

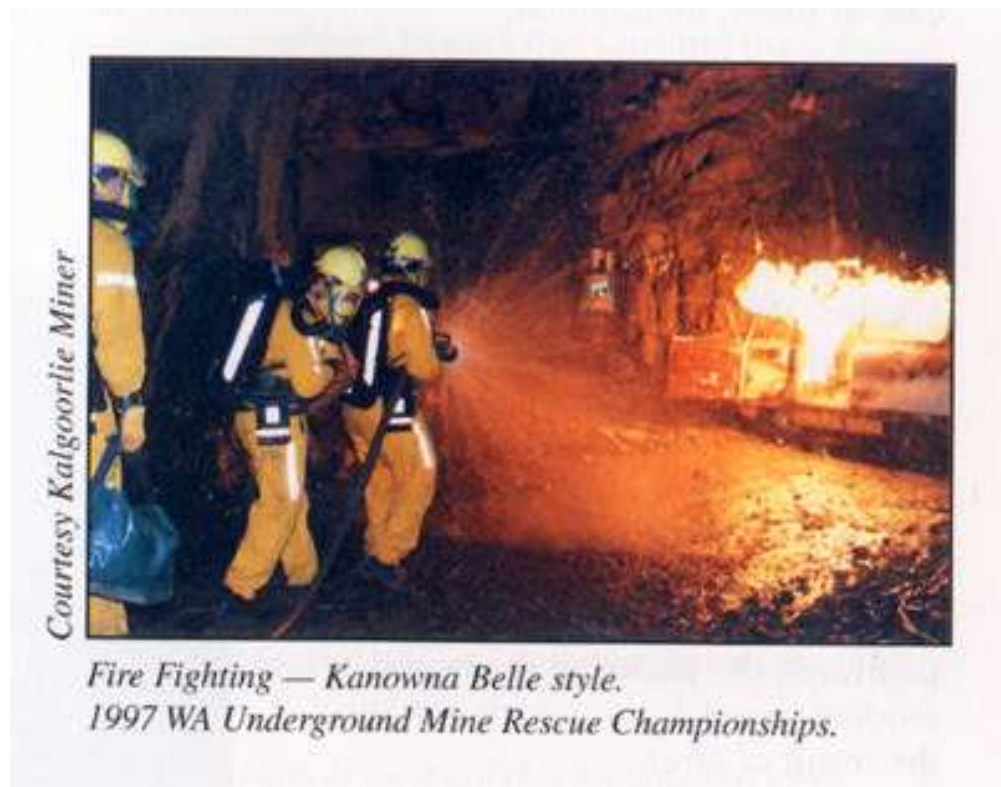

**Figure 6-3: Fighting an underground fire**

## **Underground Fire Case Study**

Due to the number of incident reports relating to underground fires that have been submitted into the DoIR, the MOD and the Western Australian Chamber of Minerals and Energy decided to dedicate a session at the Minesafe 2000

International Conference to discuss a hypothetical underground fire incident with information taken from actual cases that have been reported.

The reconstruction of the hypothetical incident was to be animated to provide a visualisation of the scenario so that the people involved in the conference reconstruction had a sense of an actual underground incident. The visualisation was also for the benefit of the audience (approximately 500 delegates) so that they could gain an understanding of the magnitude of the incident.

To demonstrate the potential hazard from a truck fire in a confined space the author was shown a photo of a haul truck on fire, but in an open area. Its tyres well alight and with thick black, toxic smoke visible. Then the author was asked to imagine such a fire being located underground and in a confined space. Figure 6-4 was the photo shown to demonstrate that this type of accident is of major concern.



**Figure 6-4: Truck on fire (courtesy DoIR)**

The MOD developed the scenario and it was the author's responsibility to develop the visualisation that would best suit the incident and the way that the hypothetical reconstruction was to be shown, and where additional information or explanation of events were required the Subject Matter Expert (SME) Mr Martin Knee from DoIR, provided the answers. The following section describes the incident as developed by MOD.

## ?? **Incident description**

*At 11:30 pm, the registered manager of the mine (who is also the underground manager) receives a telephone message in his room in the camp from the leading hand in the processing plant. The leading hand is the night shift coordinator for calls to the mine emergency number.*

*The leading hand tells the underground manager that he has received an emergency call from the underground shift-boss on N/S to say that a full haul truck is on fire in the decline, some 450 linear metres down the decline from the portal. There is no sign of the driver of the truck.*

*The truck is well alight and the shift-boss reports that it had been fully refuelled immediately before the start of the shift and that it was returning loaded to surface on its first trip of the night. The tyres on the truck are burning.*

*Through the flames and thick smoke that is being drawn down decline, the shift-boss can see that the main power cables in the decline are on fire. The poly lines carrying the air and water services and the rising main pump line have burnt through and the shift-boss has isolated both lines using valves in the decline above the fire.*

*The telephone communications line also runs though the decline and appears to have been cut below the fire, as the shift-boss cannot make contact with the crib room some 150 metres below the fire.*

*Three men were working on a sub-level at the same horizon as the crib room, charging stope rings for blasting on the following shift. The shift-boss has no idea where they currently are or what their condition may be.*

*Six other men in the loading and trucking and service crews are also working in the mine below the fire. The shift-boss has no idea where they are or what condition they are in.*

*The leading hand in the mill reports that he has received a call on the emergency telephone from the refuge chamber at the bottom of the mine and that all six members of the loading and trucking and service crews are currently safe inside the refuge. Conditions are getting unpleasantly warm, but they have compressed air and potable water and report no immediate discomfort.*

*The men in the refuge chamber report thick smoke in the decline outside and they can hear a major flow of water from source unknown to them running down the decline, but they are unable to investigate further due to the smoke.*

*Each man in the refuge chamber has a self-contained self-rescuer rated at a maximum duration of one hour at rest or thirty minutes under moderate physical load.*

The above extract provides the scenario. The next step was to develop a script (Figure 6-5) that would be used by the presenter and also identify which animations were needed, where they would be placed and their timing. Each of the animations would run for a maximum of thirty seconds.

TIME	AUDIO	VISUAL
00:00	MODERATOR	
	Description of the mine The decline runs from near the bottom of the pit to a depth of around 300 metres below surface. A number of sub-levels run off the decline into stoping areas. Ore and waste haulage is carried via the decline using 30 tonne capacity haul trucks.	Fly over of surface of mine.  Isometric view of underground workings in relation to surface features.
03:05	RESCUE TEAM CAPTAIN	
	Answers in own words. MODERATOR to bring out the point that visibility is practically nil and that the atmosphere is irrespirable.	Underground development (decline) with fire showing smoke and lack of visibility.
04:30	MODERATOR	
	The return air raise system also forms the escape route from the mine and is equipped with ladderways and platforms. Is that a good idea,?	Zoom on return air raise from bottom of mine to surface.



		Refuge chamber showing services access from decline with escape raise in background.
14:45	EMERGENCY RESPONSE CO-ORDINATOR	
	Answers in own words. MODERATOR to bring out whether the response centre and its service arrangements are adequate for this type of mine and what else might be required.	Surface showing office complex of transportable buildings.
26:50	MODERATOR	
	Through the flames and thick smoke that is being drawn down decline, the shift-boss can see that the main power cables in the decline are on fire. The poly lines carrying the air and water services and the rising main pump line have burnt through and the shift-boss has isolated all of the service lines using valves in the decline above the fire.	Close-up of burning truck blocking decline. Service lines are seen to be burnt through.
41:10	VENTILATION OFFICER	
	If the fan is reversed, the fumes from the fire will be blown up the decline, putting at risk anyone in the area above the fire. The return air raise will be full of smoke and fumes. It will take some time (calculable from the cubic capacity of the raise divided by the reverse air flow quantity from the fan) to clear the raise and allow persons to use it to escape.	Changes to show ventilation reversed and smoke blowing UP the decline from the site of the fire and exiting via the decline portal to the open pit.
93:00	MODERATOR	
END AT	Ladies and gentlemen, it seems that we have only a partial success here, despite the best efforts of all those involved. The fire was contained...	Isometric view (with fire, smoke exits via portal).

95:15	efforts of all those involved. The six men from the Refuge Chamber and the truck driver are all safe on the surface, if a little shocked. However, it looks bad for the three men who are still unaccounted for.	
-------	--	--

**Figure 6-5: Sections of the script**

The above script was also used as the storyboard to ensure that the graphics for example; smoke direction, fire, and camera movements (usually zooming into an area) matched the audio information from the script.

### **Reconstruction of Events**

All of the modelling and rendering for the reconstruct of this hypothetical scenario was undertaken using 3D Studio Max? version 3 and the software After Effects was also used to create the smoke and fire effects.

#### **?? *Mine details***

An actual underground mine was selected by the DoIR from a list of disused workings. The mine information - detailing ventilation, declines, minor works and survey information was provided as paper based plans. A CAD model was produced as shown in figure 6-6, but this was not available. Therefore all information had to be extracted manually from the paper-based plans.

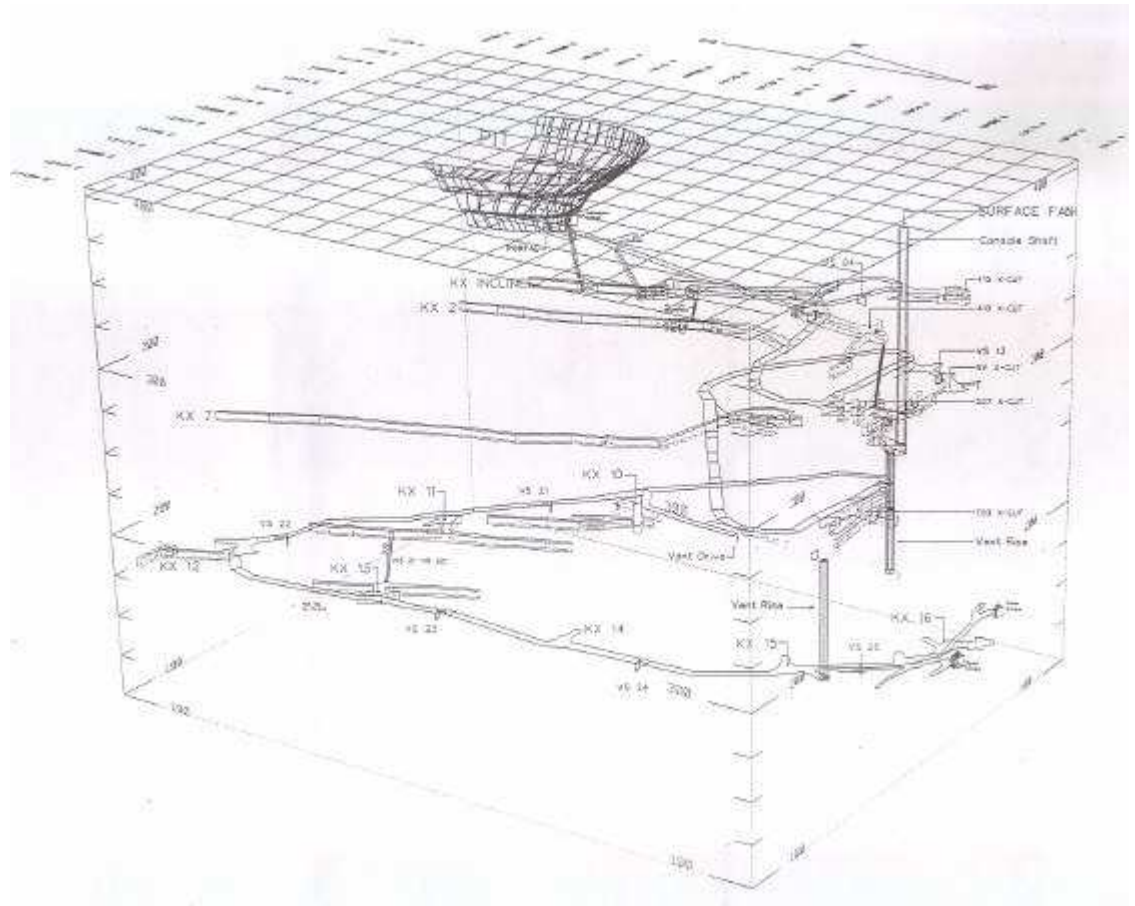
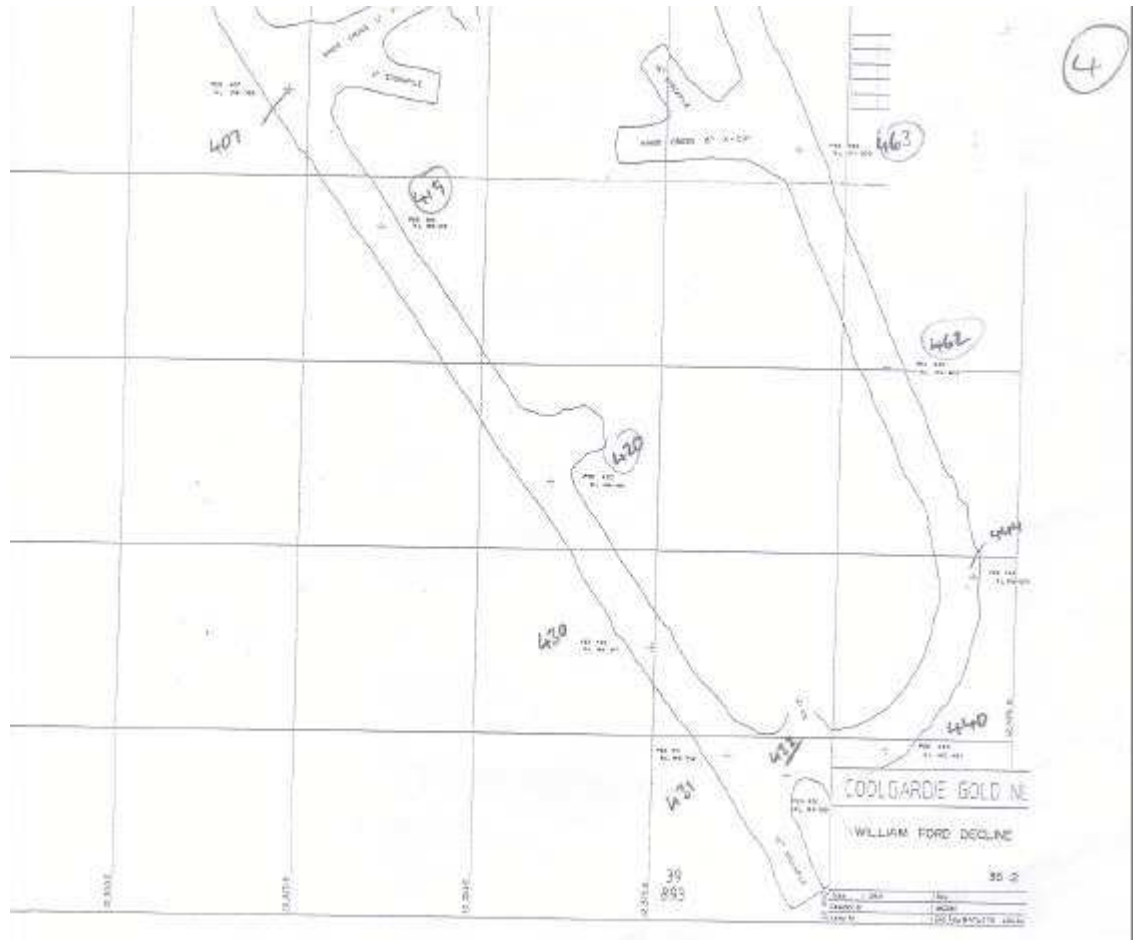

**Figure 6-6: 3D representation of the mine**

The reconstruction of the underground mine was undertaken in the following stages

### **Stage-1**

The declines, ventilation and relevant information were measured from the supplied survey plans(Figure 6-7). The Easting, Northing and Relative Level (RLs) for points were obtained from the plans by manual process, using a scale ruler and parallel ruler. In most modern mines, the mine plans and information would be available electronically.



**Figure 6-7: Measuring XYZ from 2D plan**

### **Stage-2**

Each point used was an actual survey reference point and all information was placed into a spreadsheet (Figure 6-8). This also served as a check to ensure that the measurements taken were correct. Some of the factors, which were examined, included the gradient of the decline and survey point locations, ensuring the decline was going downhill and the points were in the area indicated.

PEG No	RL	Difference	Z Depth	X Easting	Y Northing	Notes
1	359.797		0	12262.85	10715.72	Start of decline (PORTAL)
5	354.361	5.436	5.436	12262.85	10766.43	
10	344.805	9.556	14.992	12264.28	10847.86	
13	341.805	3	17.992	12264.28	10869.29	
14	340.734	1.071	19.063	12250	10886.43	First Turn (Left)
17	336.335	4.399	23.462	12223.56	10889.29	
20	332	4.335	27.797	12183.57	10895.72	
22	330.99	1.01	28.807	12176.43	10892.15	
29	329	1.99	30.797	12167.86	10887.86	
104	329.878	29.919	29.919	12260.71	10712.15	MINOR
175	330	-0.122	29.797	12293.56	10637.85	WORKIN GS Not
235	265	94.797	94.797	12266.43	10787.15	MINOR
267	264.429	0.571	95.368	12304.28	10720.72	WORKIN
39kf	266.072	-1.643	93.725	12369.99	10559.29	GS Not
216	263	96.797	96.797	12240.71	10851.43	MINOR

**Figure 6-8: Spreadsheet of pegs and measured co-ordinates**

### Stage-3

Each X, Y and Z co-ordinate i.e. northing, easting and depth was entered (manually) into 3D Studio Max using the 'Create Point' function. This was a time consuming process as each point had to be entered for each corresponding point on the spreadsheet

### Stage-4

At the completion of entering the points, the next step was to join each point so that the points relating to the decline were connected and the points relating to other paths, such as ventilation ducts were connected properly. This was accomplished by selecting the points required and using the 3D Snap option.

### Stage-5

To create a 'tunnel' look, the lofting function within the 3D studio max software was used. Lofting changes the characteristic of 'the line' to a required form and colour. As demonstrated in figure 6-9 the line will be lofted by a circle character producing a cylinder.

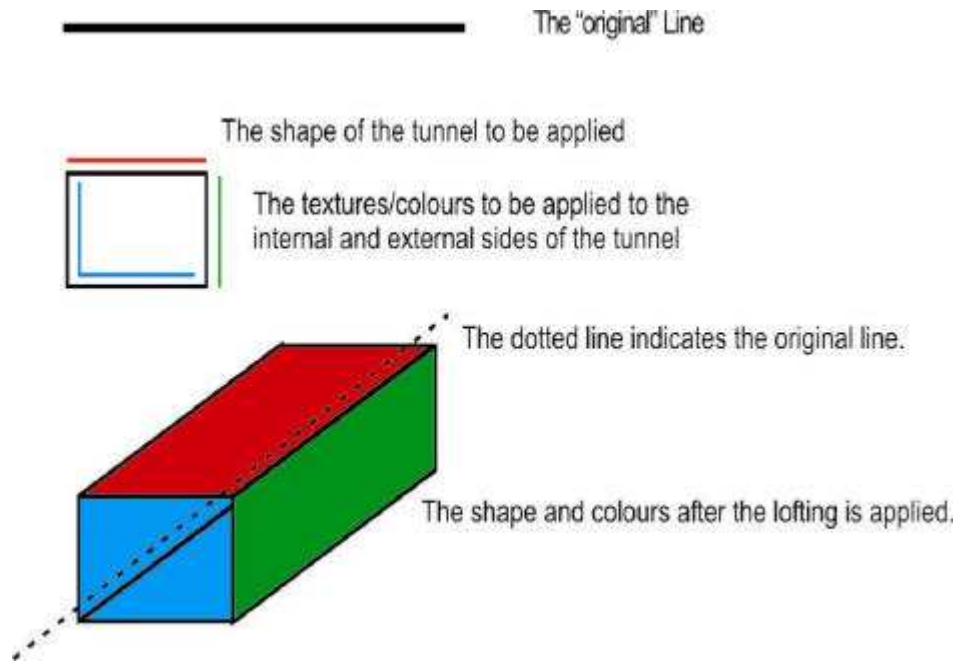

**Figure 6-9: Lofting**

Figure 6-10 represents a 3D view of the underground workings of the mine. The green objects represents the decline, the red object represents a ventilation shaft and the blue represents the vertical ventilation shaft that takes the air to the surface.

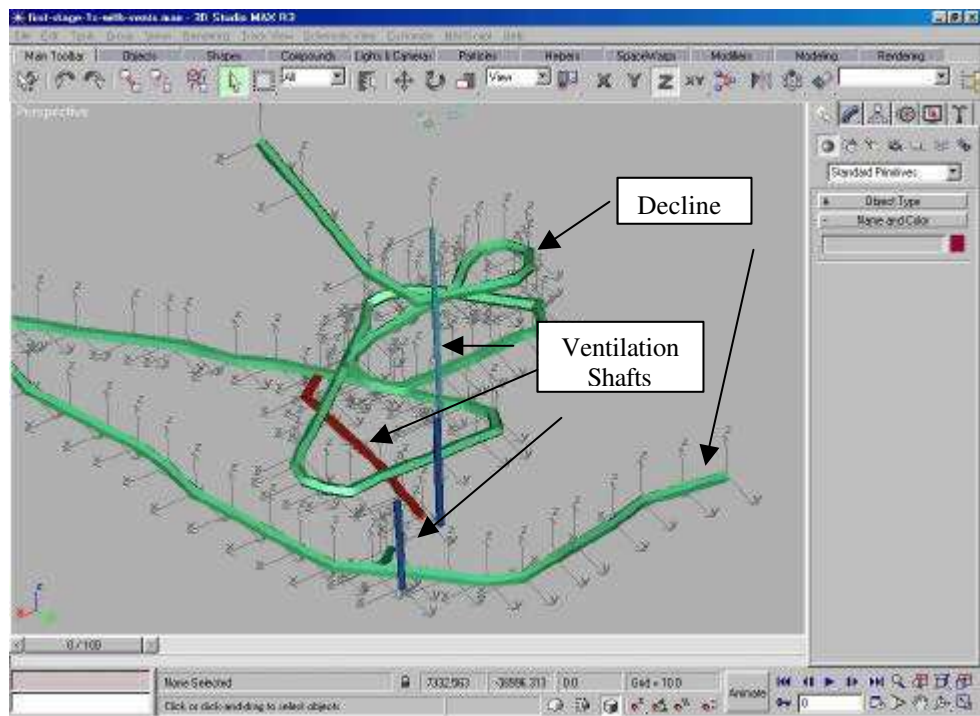

**Figure 6-10: Screen capture showing declines and ventilation shafts**

The 'skeleton' (Figure 6-10) model of the minesite and decline had now been created. The model was further developed with the assistance of Mike Annear to establish the terrain and produce a completed model and animation from the supplied script.

The terrain was taken from a previous model and placed on top of the skeleton model. The texture map that was overlaid on the terrain was taken from an aerial photograph of a similar area in regional Western Australia. To demonstrate the underground workings it was decided to show the top of the minesite with a truck entering the decline then removing part of the terrain to expose the decline so that a view of the terrain, minesite and the decline and ventilation shafts could be seen, ensuring that a good perspective of the mine was presented. Figure 6-11 demonstrates the final model and the cut away section



**Figure 6-11: Rendered sectional mine model**

### ?? ***Vehicle details***

The SME (Mr M Knee) defined the type of haul truck to be used as a 30 ton type machine. It was agreed to make a generic type of haul truck, as this was a hypothetical incident the brand type was not a factor. The truck was built from supplied dimensional plans (Figure 6-12) and using a base model supplied by the University of Nottingham's AIMS Research unit.

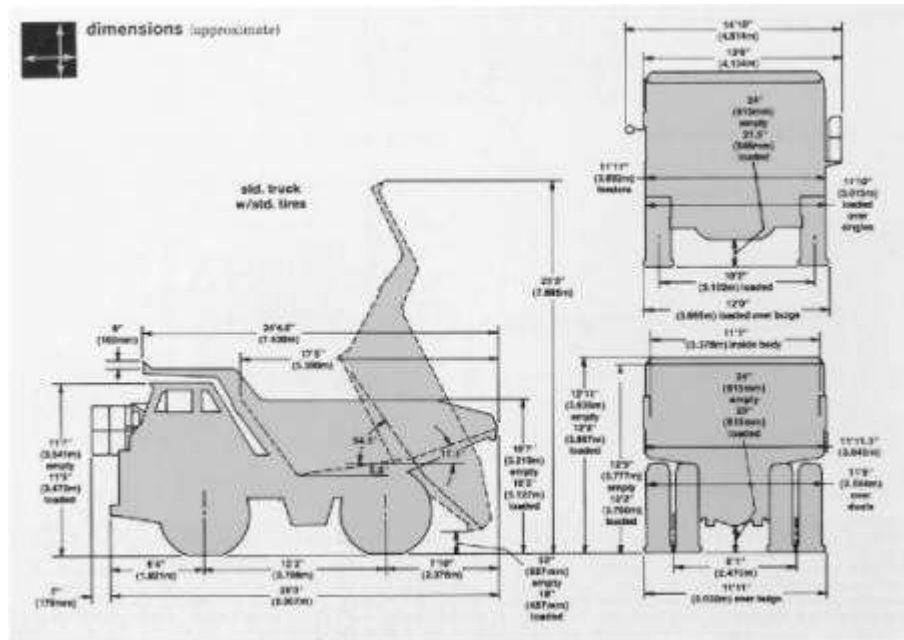

**Figure 6-12: Haul truck 2D drawing with measurements**

The supplied model was modified to suit, using the plans, and by photographs and digital images of actual trucks available from various visits to actual minesites by the developers. A wire frame was produced (Figure 6-13) and using ordinary and digital photographs the external covering (or texture) was added (or mapped).

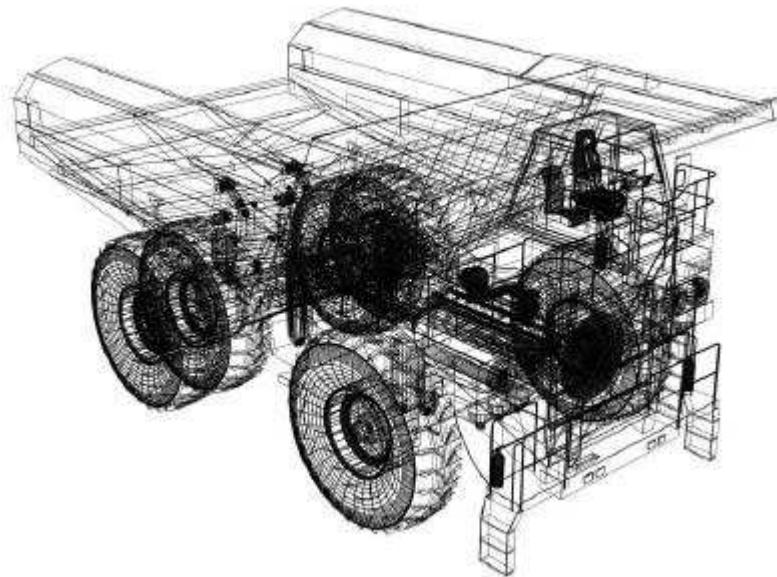

**Figure 6-13: Wireframe of haul truck**

Continuum Resources an industry partner with Central TAFE also assisted in the modelling, using the After Affects software to produce the smoke and fire and



render all of the animations on their render farm. Figure 6-14 shows a final render of the truck in the decline on fire.



Figure 6-14: Haul truck on fire in decline

### ?? ***Assembling the events***

As with most reconstructions an overview of the existing environment was developed to establish the scene, the following graphics were developed:

?? Overview of the mine with a sectional cut away (Figure 6-15) to show workings and ventilation system indicating direction of airflow.

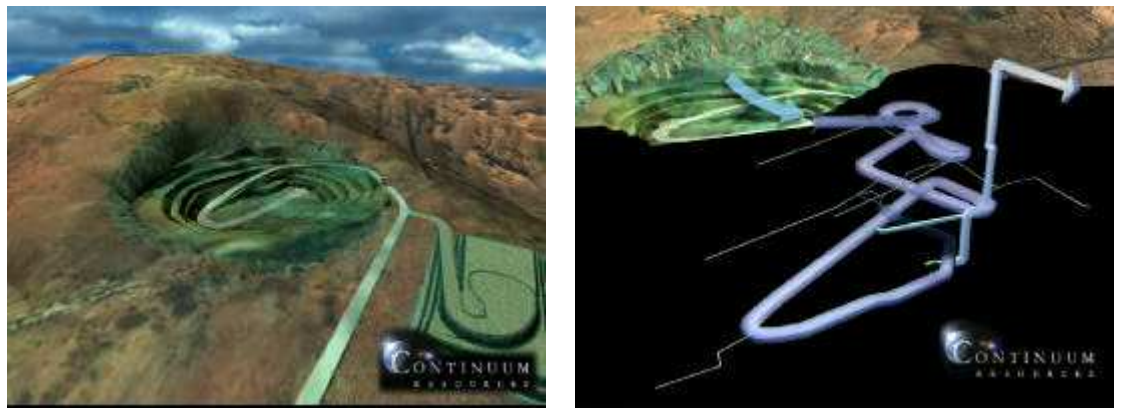

Figure 6-15: Overview of mine and sectional cut away

?? Location of first aid building and mine rescue equipment within the minesite.

?? Additional information on the submersible pump being used to keep the rising water at a safe level.

?? View of the electrical and communication cabling and position of a refuge

chamber and location of water pump to extract rising water (Figure 6-16).

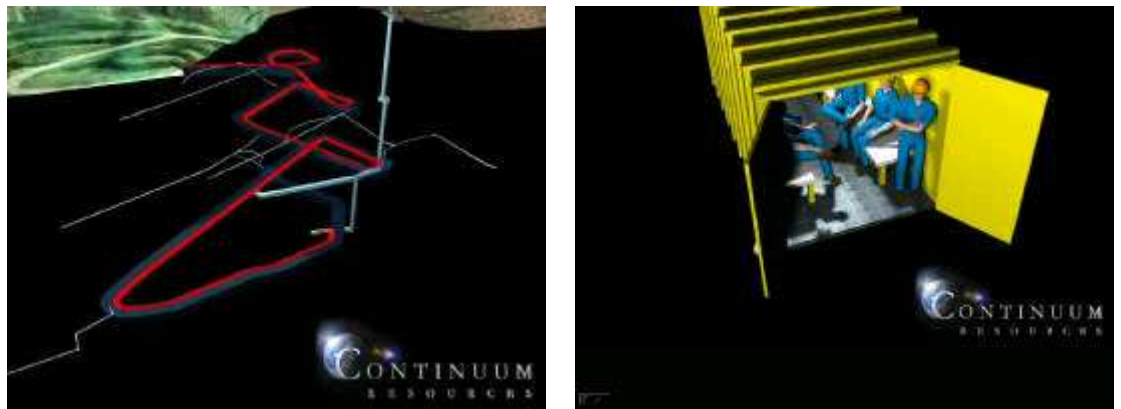

**Figure 6-16: Cabling and Refuge chamber**

?? Figure 6-17 provides an overview of the evacuation route from the refuge chamber (down the mine) to the surface via the extraction fan.

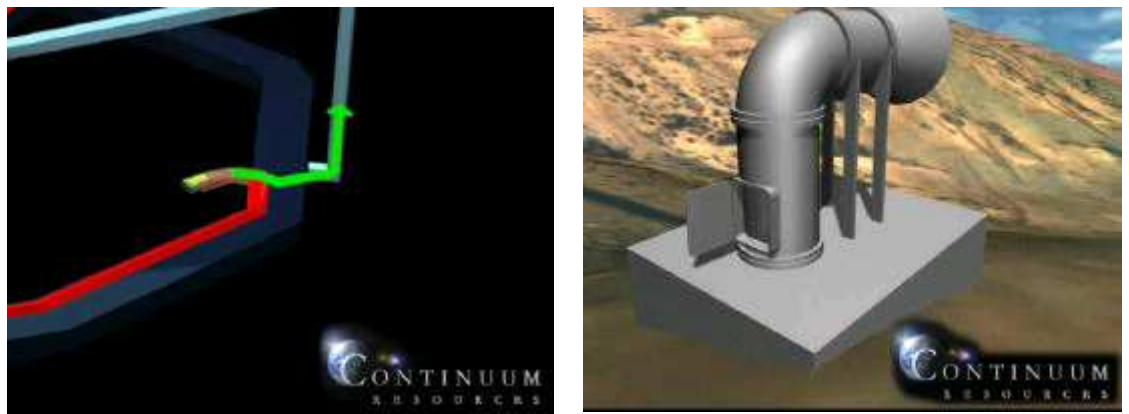

**Figure 6-17: Evacuation route**

?? The next stage of the reconstruction was to develop each of the sequential events that occurred. The graphics were developed to provide visual information for the panel of experts and to provide advice and feedback as to what they would and should do and what needs to be done as a result of the events. The following graphics depict each of the events on which the panel had to comment as well as their role playing duties and responsibilities.

?? The location of the incident within the sectional cutaway indicates how far down the decline the truck was. The view also showed the truck on fire and the type of fire (tyre) and the direction of the smoke (Figure 6-18).

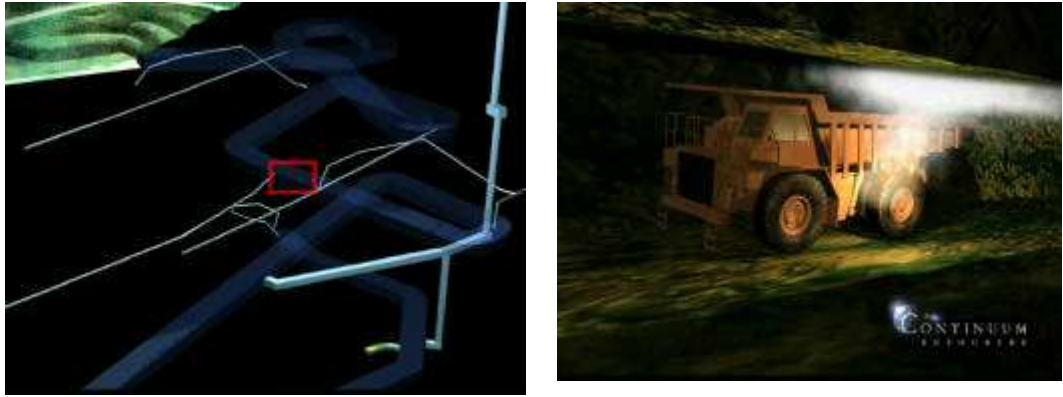

**Figure 6-18: Location of incident**

?? The reconstruction showed the fire damaging the electric and communication cabling as well as demonstrating how the ventilation system is moving the smoke and fumes throughout the mine (Figure 6-19).



**Figure 6-19: Loss of communications and smoke direction**

?? The men are held up in a refuge chamber and their escape route was not available due to the smoke and toxic fumes (Figure 6-20).



**Figure 6-20: Men safe in refuge chamber**

?? A single solution (of reversing the fan) was presented as a possible solution but there was an intent to generate additional solutions (Figure 6-21).

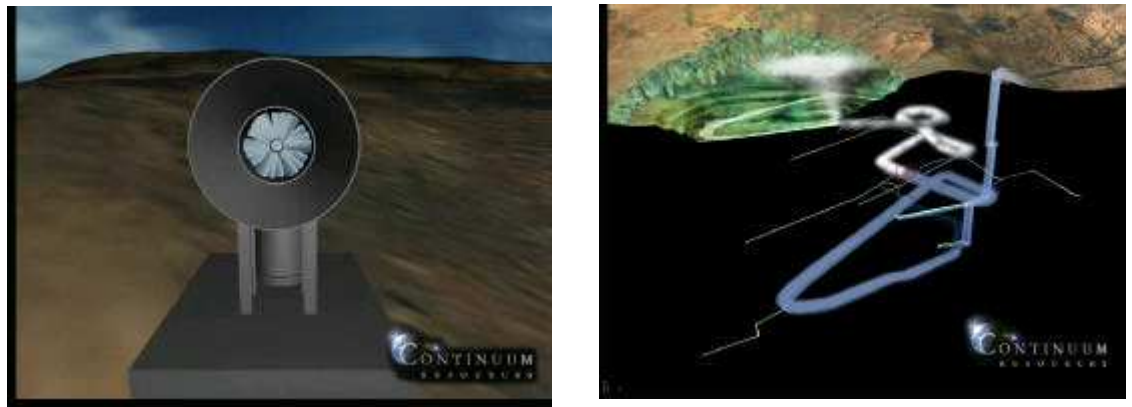

Figure 6-21: Reversing fan direction

?? ***Showing the completed reconstruction***

The reconstruction was scheduled to be shown at the Minesafe 2000 International Conference in Perth WA, entitled, Mine Disaster Hypothetical (Figure 6-22).

<p><b>Tuesday 5 September 2000</b> Understanding, Achieving and Maintaining Competence in the Workplace Health and Safety Training Innovations Risk Management and Safety Management Systems Mine Disaster Hypothetical</p> <p>This on-stage exercise will be conducted utilising operational staff in a simulated underground potential disaster situation. A realistic time scale will be in place to test the adequacy of emergency response and rescue resources at a mine site.</p>
--

Figure 6-22: Extract from Minesafe2000 brochure

In front of over 500 delegates a panel of industry experts was formed. This panel viewed the hypothetical scenario under the direction and control of a facilitator and the presenter. Neither the panel nor the delegates had seen or discussed the scenario prior to the presentation.

The expert panel was there to address the events that were to unfold as the facilitator presented them. The panel members had to address what they would do in carrying out their specified roles The involved included:

?? Mr Les Buchbinder - Lawyer and Facilitator

?? The panel was made up of the following

?? Mr Martin Knee - acting State Mining Engineer

?? Mr Lee Randford - Director General Department of Minerals and Energy

?? Mr Stevenson - Secretary to the Premier of WA

?? Mr Simon Thompson - District Inspector, Mining Operation Division

?? Other industry personnel from the mine, Mine Rescue captain, Ventilation officer, Mine manager, Trades and Labour Council.

?? Television presenter and Newspaper reporter.

The animations were presented in a PowerPoint format and when the facilitator reached an event that had been animated, the presenter activated the appropriate animation. The animations were also developed to keep the audience involved and interested in the presentation.

### ?? ***Outcome of reconstruction***

There was no official response or formal assessment of how the reconstruction was received by the 500 delegates. The best indication of its success was that the Mine Disaster Hypothetical presentation was scheduled for one hour, the panel took one hour and forty-five minutes to discuss the various options and relevant problems. From comments received not many (if any) of the delegates walked out of the conference hall during this extended session..

After the presentation two unsolicited comments were received regarding the use of the animations.

*I cannot wait for this technology to appear in the courts – however it may make my task a little more difficult as I may not be able to talk as long as I do now. Mr Les Buchbinder – Lawyer and Facilitator of the hypothetical.*

*I was very impressed and could see this type of presentation being used in Coroners Courts to help with information clarification within some mining accidents. Mr J Torlach - WA State Mining Engineer.*

Another indication that the reconstruction was successful was the level of enquiries at the Central TAFE and University of Nottingham combined exhibition stand, demonstrating the use of CG&V. After the presentation Professor Denby, Dr Schofield and Ms Goodwin (from Nottingham) noticed significant increase in the number of people enquiring about the use of CG&V for the mining industry.



## Training Application

The training application consisted of a modification of the original reconstruction to include a script all presented in a PowerPoint presentation. The presenter uses a script to ensure that as certain key points are being raised, the relevant animations are displayed.

Also included in the training application CD was a presentation developed by the Mining Operations Division specifically for highlighting the problems and statistics relating to underground fires

### ?? *The design and setup*

The animations were imported into Microsoft's PowerPoint software. The reason being that the graphics and the script could be used either manually or alternately set to time-lines. The application had to fit onto a single CD and had to be accessed using a low cost personal computer and the software had to be easily available either via a supplied viewer or software that was already installed on the computer.

The following demonstrates what the training version looks like. It is similar to the original presentation except that additional text has been added providing instructions.

?? The first slides mentioned the scenario and the list of players required (Figure 6-23).



Figure 6-23: The players and task

?? An overview of the minesite is also provided (Figure 6-24).

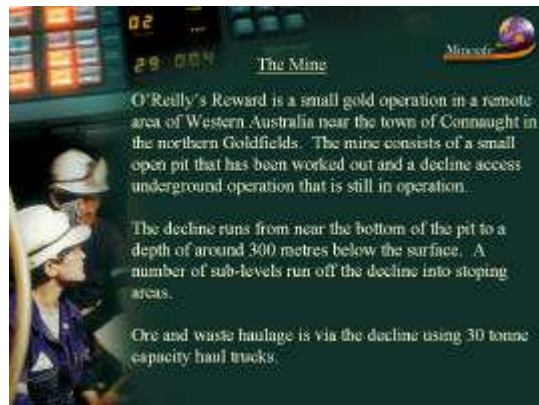

**Figure 6-24: Overview to the mine**

?? A description of the ventilation system of the minesite (Figure 6-25).

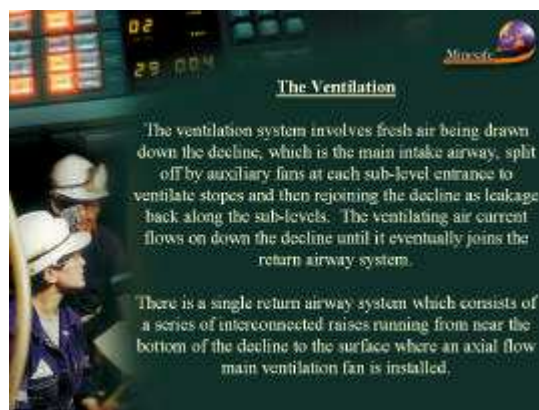

**Figure 6-25: Ventilation system described**

?? Additional information was also provided on the refuge chamber and circumstance surrounding the incident was presented (Figure 6-26).

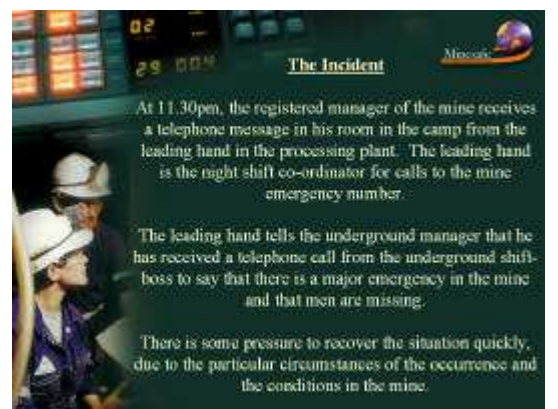
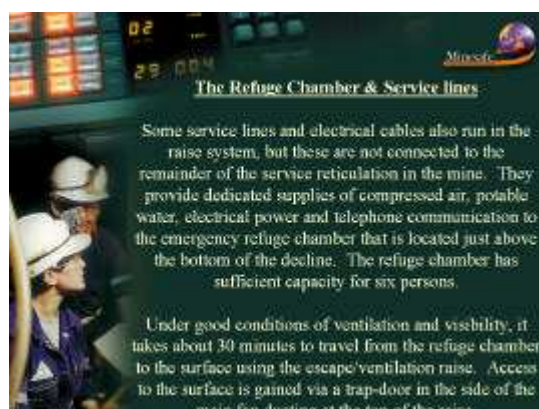

**Figure 6-26: Additional information**

The remaining slides continue to alternate between the script that describes the upcoming slide and the animations. The animated slides are the same reconstruction animations shown in the Minesafe 2000, Mine Disaster Hypothetical session .

The final slides (Figure 6-27) contained the following questions and acknowledgments:

?? Is this is the only solution and could a similar event happen at your minesite to ensure that the participants start to relate what they have participated in to their environment. Finally acknowledgements.



Figure 6-27: Final training slides

### ?? **Outcome of application**

No formal assessment has been compiled as to the success of this training application. Only anecdotal evidence is available indicating that the application has merit and is worth pursuing.

The use of CBT material on minesites is very limited. The minesites visited over the years only showed that computers were used by the administration staff and in specialised areas (e.g. mine planning and scheduling).

The use of this type of application is useful when a company is in a position to stand down production people for a few hours or when staff are rostered off and able to attend training sessions at the mining companies designated training establishment. Further applications of this training package are being investigated.



## **Conclusion**

Underground fires in Western Australia have been a major concern to the Department of Industry and Resources, Mining Operations Division, for a number of years.

The opportunity to present a hypothetical scenario (based on actual incidents) at an international forum using computer generated animations to provide additional information and a visual reconstruction of the event, was seen as an ideal opportunity to raise the concerns of the regulators regarding the increasing hazard of underground fires within the mining industry.

The significant advantages of this 'virtual' training environment over a real one is its enormous flexibility. The virtual environment can be used as a basis for training in a wide range of different scenarios so that trainees can learn to cope with many different situations, some of which are impossible to prepare for in the real world.

The second advantage is that trainees learn by their active participation i.e. (role playing). This has a significant effect on their ability to retain what they learn, as compared with the use of other techniques such as videos or books.

The use of reconstruction animations of hazardous incidents allows SMEs to continually review the incident and provide additional comments and explanations, whether it is for legal or internal investigation.

The next step is to use the reconstructed incident as a training tool. In this case study the use of text information to describe the scenario and provide additional information to enhance the understanding of participants was a useful addition to the original presentation. The finished product can be controlled by the individual and used as a tool-box training application or a class room role playing tutorial.

## 7 CASE STUDY 2 – SURFACE MINE ACCIDENT

### Introduction

Truck accidents and incident are a major problem both underground and on the surface. Due to their size many forget that they like any other vehicle are susceptible to accidents. The following pictures (Figure 7-1) were presented in the DoIR Minesafe magazine (DME, 2001c) to demonstrate that trucks are a problem and people need to be made aware of the increased hazard of such a large mobile plant on a minesite such as:

?? Lack of viewing areas from the cabin of the truck.

?? Increased stopping distances of these vehicles.

?? Weight of vehicle (with or without load).

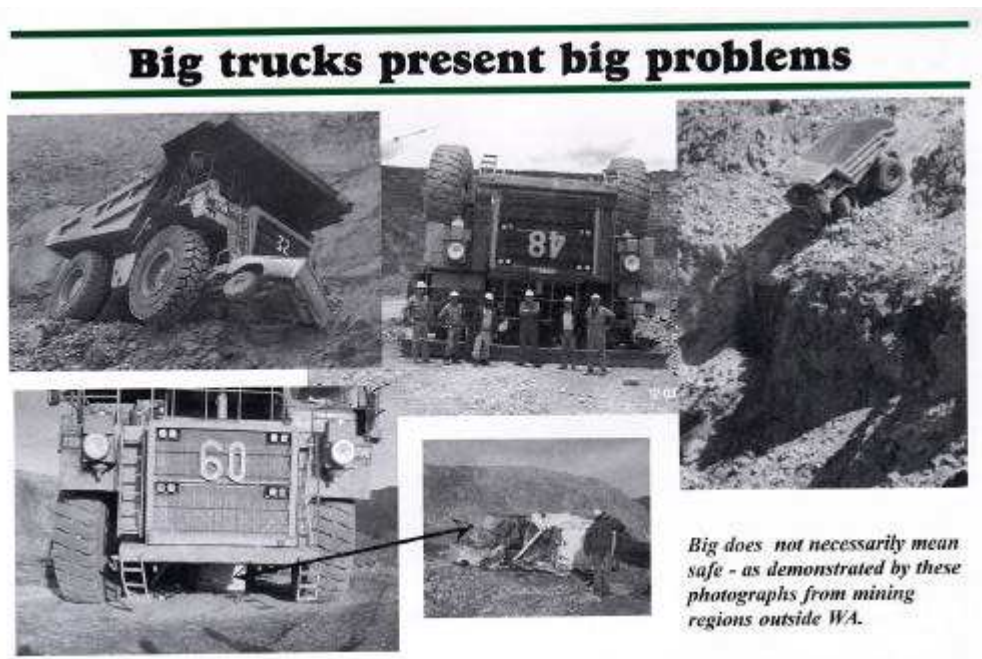

**Figure 7-1: Big truck present big problems**

As the following graph (Figure 7-2) demonstrates, from 1994 up to December 2001, mobile plant incidents were the second most frequently reported accident with 1,944 being reported. Fires recorded 3,787 and other incidents 1,279 (DME, 2001d).

Also on the graph, a breakdown of the actual mobile plant incidents reported are presented, as well as the number of fatalities.

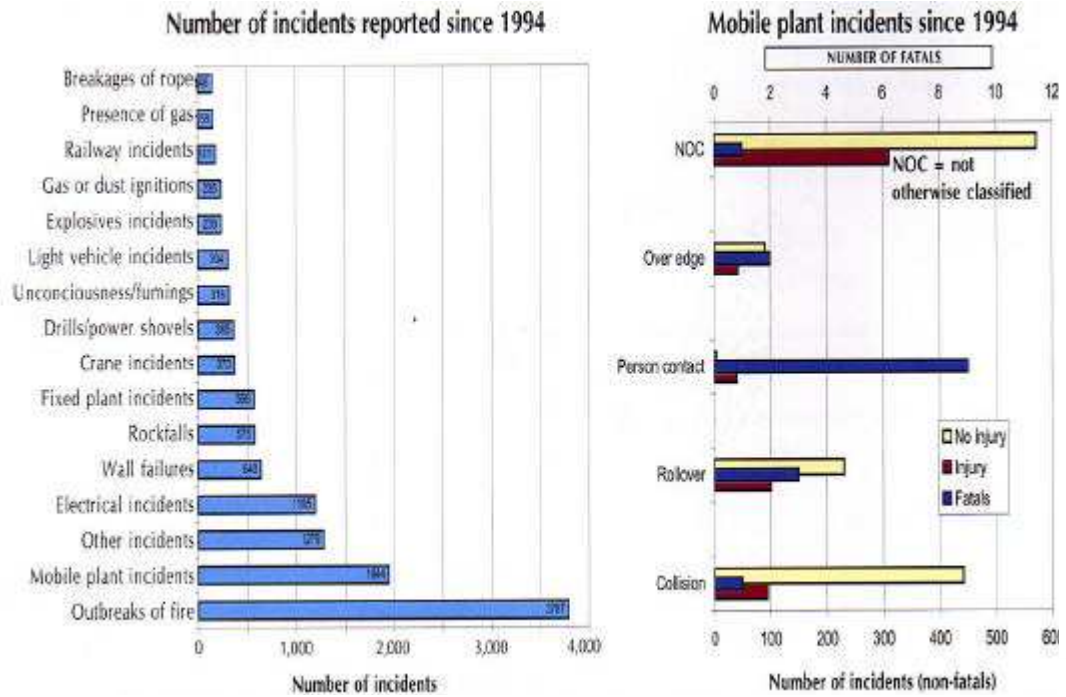

**Figure 7-2: Incidents reported and number of mobile plant incidents**

Apart from injuries to personnel every accident means a reduction in and possibly loss of production and loss of equipment and if a fatality occurs, loss of a life. This case study will look at a hypothetical incident that is based upon actual events and presents information leading up to and including a truck falling over the edge of a stockpile.

## Over the Edge

As previously mentioned in Case Study 1, the DoIR release various magazines, reports and data-sheets to ensure that the industry is aware of hazardous situations, which could lead to accidents and general OH&S information,.

Trucks falling over an edge or rolling over have been written about since 1990, in the first year of the magazine MINESAFE produced by the DoIR's Mining Operations Division. The November edition showed a vehicle precariously balanced on its rear on the edge of a stockpile and the title of the article was called DUMP PRECAUTIONS and again in the December 1991 edition of the magazine the front cover showed a vehicle that had gone over an edge (Figure 7-3) although this was a serious incident it could have been much worse if the truck had been carrying its load of explosives, which could have led to a very large incident.



**Figure 7-3: Explosives truck over the edge (DME, 1991)**

The effectiveness of showing trucks that had somehow gone over the edge of a stockpile or windrow was also demonstrated in a cartoon like manner as a poster (Figure 7-4). These posters were sent to all minesites and placed in areas where drivers and minesite personnel would see them and thereby reinforcing the message that trucks can easily go over an edge of a dump.



**Figure 7-4: Nugget poster**

Another issue of the Minesafe magazine dated December 1994 (Figure 7-5) depicts six photographs of trucks that had either gone over an edge or rolled over, the caption this time was 'When will it Stop?'



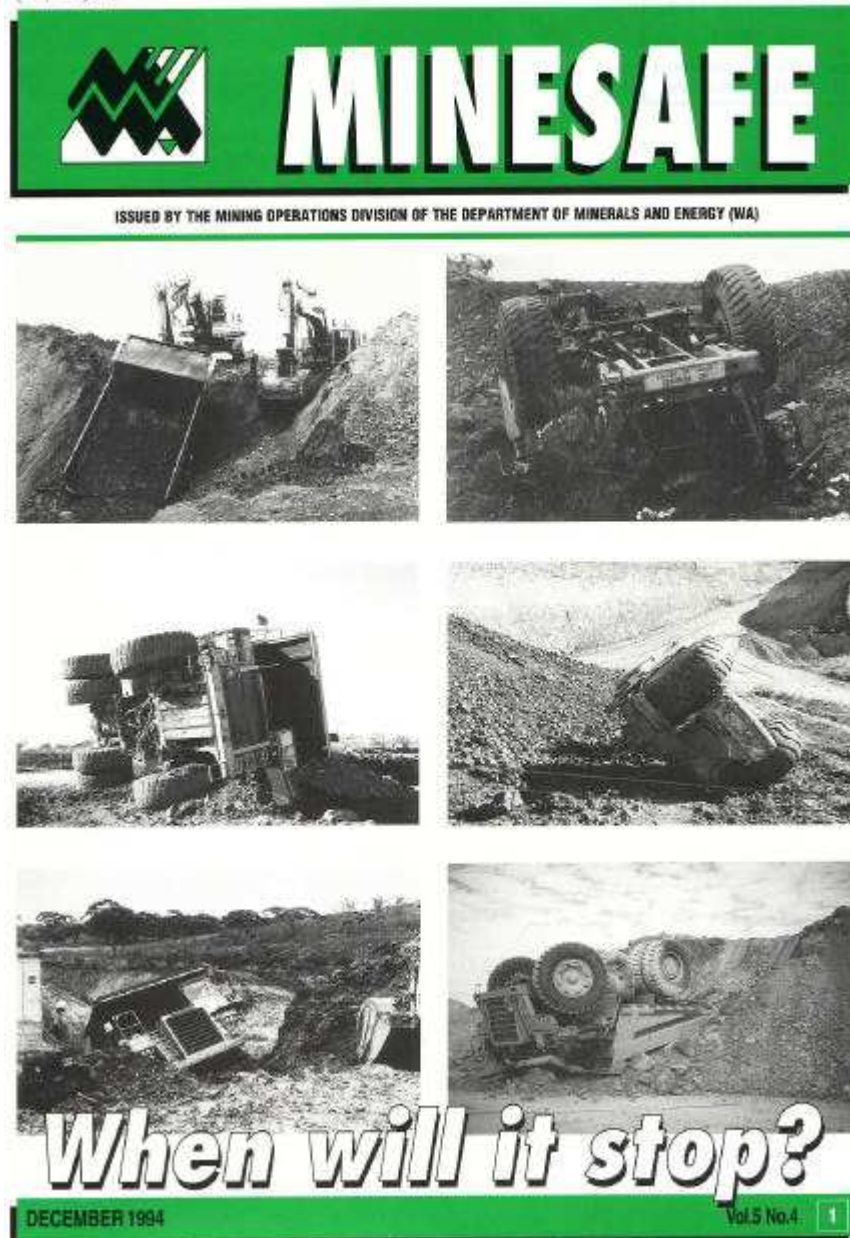
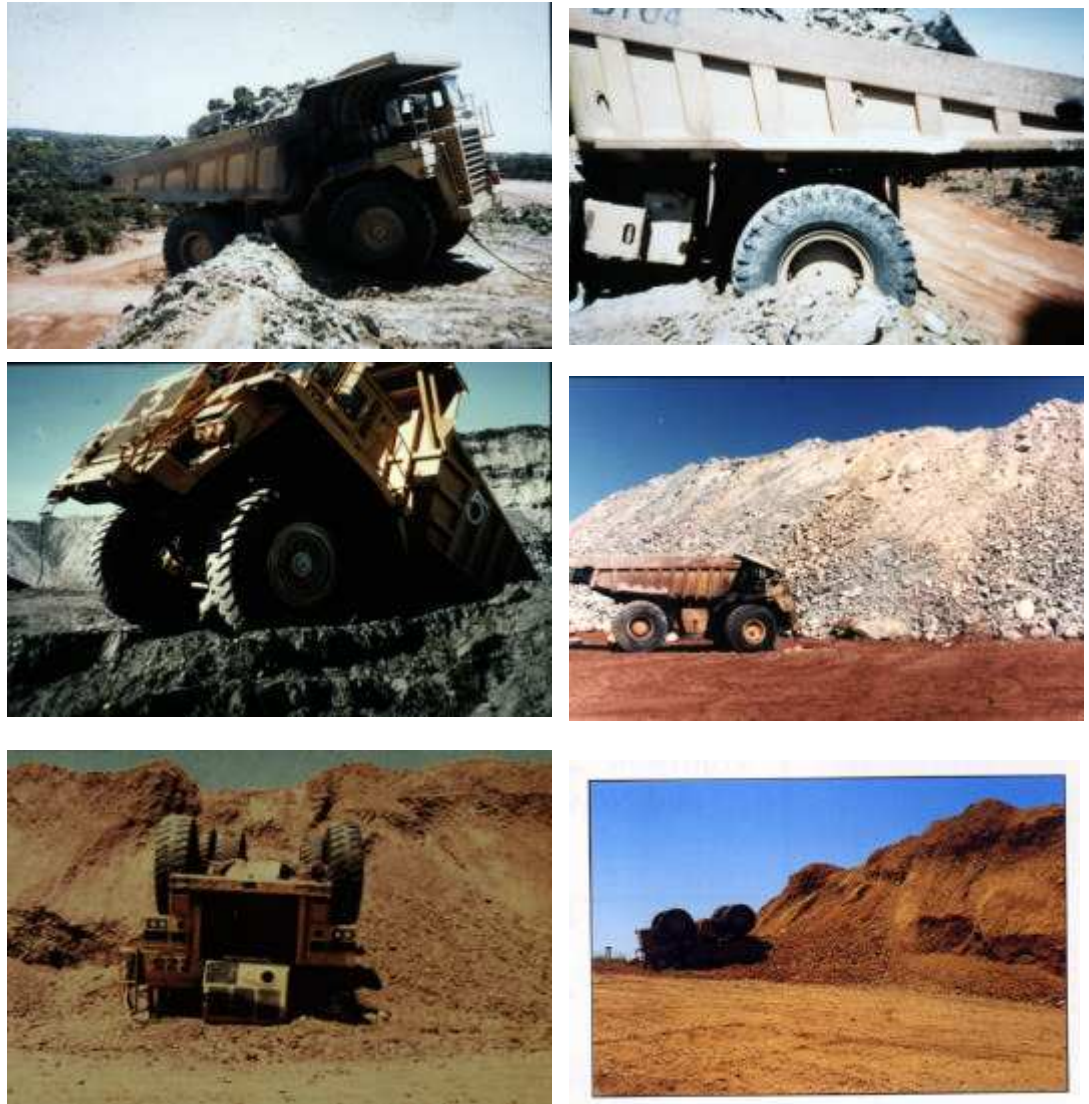

Figure 7-5: Minesafe magazine Dec 1994

The most common incident occurs where a haul truck is reversing to 'dump' its contents. The following photographs (Figure 7-6) show haul trucks in various stages of reversing and falling over an edge.



**Figure 7-6: Montage of overturned trucks (courtesy DoIR)**

In addition to the visuals the DoIR provides reports within their hardcopy publications such as MINESAFE (similar to those in Case Study 1). The reports are also available from the DoIR website (EXIS, 2001) relating to some of the more serious or potentially serious incidents that have been reported. It demonstrates that the problem exists and these accident and incidents can happen easily.

**?? Significant Incident Reports (SIRs)**

Significant Incident Report No: 26, October 1991

*Subject: TRUCK TOPPLED OVER EDGE OF STOCKPILE*

*Incident: A Caterpillar 769 haul truck was reversed to the edge of a 6*

*metre high stockpile which collapsed causing the truck to topple over the edge and come to rest upside down at its base. A front end loader was digging at the base of the stockpile to feed a crusher whilst dumping operations were being carried out above. The truck driver suffered serious injuries including fractured ribs, shoulder and several vertebrae.*

**Cause:** *There was no effective backstop or spotter on the stockpile at the time the truck was being tipped. The edge of the stockpile had been undercut by the loader immediately below the point at which the truck was being tipped.*

Significant Incident Report No: 74, May 1997

**Subject:** *DRIVER KILLED IN TRACTOR ROLLOVER*

**Incident:** *A self employed fencing contractor was fatally injured in April 1997 whilst constructing a fence down a dam wall in the south west. He was driving a Massey Ferguson tractor across the slope of the dam wall to drill a post hole when the tractor rolled sideways pinning him beneath the rear wheel.*

**Cause:** *The tractor was being driven across the steep embankment. The tractor was not fitted with a Roll Over Protective Structure (ROPS) nor any operator restraining devices.*

?? **Incidents Reports (IRs)**

Incident Number: 503, May 2001

*Type of Accident: Truck /Mobile Equip. Over Edge (Fatality)*

*The operator of a dozer was killed when his vehicle breached the edge on the bench on which he was working and fell approximately 100 metres. The deceased operator was found 40 metres up the rill of broken material from the final position of the dozer.*

Incident Number: 518, December 2001

*Type of Accident: Truck /Mobile Equip. Over Edge (injury)*

*The operator of a dozer sustained a fractured shoulder when the vehicle toppled over the edge of an old quarry, while clearing vegetation from a*

*disused stockpile. The dozer fell approximately 5 metres before landing on its roof.*

?? **Safety bulletin**

Safety Bulletin No: 20, June 1996

*Subject: SEAT BELTS AND RESTRAINING HARNESS IN HEAVY EARTH MOVING EQUIPMENT*

*Details: The fitment and wearing of seat belts (as a minimum standard) is now required under Regulation 4.16 of the Mines Safety and Inspection Act Regulations (1995).*

*The Mining Inspectorate has formed the view that the wearing of seat belts across the industry is now a general practice (although not universal). This view is derived from both direct observation and from an examination of accidents and incidents in which persons in vehicles have been found on investigation to have worn belts or restraint harnesses and have generally escaped serious injury.*

*However, there is an increasing experience of injury due to: seat belts or harnesses being inadequately attached or maintained, resulting in defective performance.*

*Failure of the attachment of the seat to the vehicle or of a movement restraint component of the seat attachment, can result in injury to the person. Such failures have been variously attributed to poor design, inadequate maintenance, deterioration due to wear and tear and corrosion, and failure to ensure the integrity of restraint components following damage or detachment in service.*

*Injury has also resulted from inadequacy of the restraint itself; for example, the use of lap seat belts instead of a more comprehensive harness.*

*Action Required*

*Review the integrity of design and quality of manufacture and fitment of the system as supplied, to determine if it is adequate and fit for the application; (for example sufficiently robust and durable in service, whether a lap and sash or full harness is appropriate).*



*Maintain vigilance on the condition of the components in service, and in particular on the maintenance of the seat and restraint.*

*Ensure that the integrity of these components is not affected by other maintenance work on the equipment.*

*Ensure that all persons are instructed in the use, adjustment and maintenance of restraints and that operators wear them.*

From the information presented to date, and from the available statistics it appears there are recurring problems with mobile equipment. The root cause of mobile equipment rolling over or going over the edge could be; brake failure, loose ground, wet ground, action of other vehicles and/or operator errors.

This report is not investigating causation but demonstrating that mobile equipment is the second highest reportable accidents and that when an accident occurs it is not necessarily due to a single vehicle fault.

## **Over the Edge Case Study**

The author sought the DoIR's permission and assistance to select an appropriate case study relating to trucks going over an edge. The DoIR was a little reluctant to nominate past or current incidents that have been investigated. The reason being that the reconstruction may be seen by the industry as a reinvestigation.

The case study selected focuses on many reportable offences that a new inspector needs to identify and was partly based on the incident demonstrated in figure 7-7.

## ONCE MORE WE ARE TALKING SEATBELTS!

Seatbelts are one item of safety equipment, that you never want to put to the test. For most people belting up is a reflex action. For those who still haven't adopted this safe practice, it may become the last lesson you **never** learn.



Long drop with seatbelt – ALIVE!



Short drop – no seatbelt. FATALITY

On mines, ROPS cabs are designed to stop the operator being crushed in a vehicle when it rolls over. If you aren't wearing the seatbelt, you won't damage the inside of the cab as you are thrown against it – it will damage you.

More importantly the seatbelt may save your life when it stops you from being thrown out of a vehicle during a rollover or collision.

Seat belt maintenance is critical. Belts need to do their job without any risk of failure. They are designed to hold you in a position that minimises the chances of injury.

## BE KIND TO YOURSELF

DECEMBER 1997

Vol.8 No.4

1

Figure 7-7: Minesafe magazine Dec 1997

Data for the case study was purely text based and had been developed from a number of similar accidents and incidents. The information was presented as a typical brief that is to be presented to a legal team for consideration for prosecution. The training manual is known as the Prosecutions and Legal Proceedings Course (Figure 7-8).

**of Western Australia**  
**Mining Operations Division**  
Prosecutions and Legal Proceedings Course  
Presented in Association with the Crown Solicitor's Office

**EXAMPLE OF BRIEF FOR PROSECUTION**

**Figure 7-8: Prosecutions and Legal Proceeding Course**

The manual was set out as if it was a real accident and the document was written to be used as a brief for possible prosecution. The manual contains the following information:

- ?? Summary of Facts
- ?? Suggested Charges
- ?? Section 9 of the Mines Safety and Inspection Act 1994
- ?? Report of the District Inspector of Mines
- ?? Report of Special Inspector of Mines (Machinery)
- ?? List of Witnesses
- ?? Investigators Statements
- ?? Witness Statements
- ?? Records of Interview
- ?? Plans
- ?? Photographs

This hypothetical case study was designed and developed using real data that was readily available from fatalities and accidents reports of the DoIR.

The hypothetical accident involves the training of a haul truck driver. During the training, the truck was driven onto a stockpile carrying a load of ore. As the truck tipped the ore, the ground beneath the trucks rear wheels collapsed and the truck slipped over the edge and overturned. The reconstruction shows the factors that led to this accident and also how the accident could have been avoided.

## ?? **Accident scenario**

*On the morning of 24 May, Mr John David Spicer was undergoing training as a haul truck driver at the mine. He had been assigned to the truck operated by Ms Angela Maria Zanetti who was to conduct the training. Mr Spicer was seated in the passenger seat in the truck cab while Ms Zanetti occupied the operator's seat. The seat belt on the operator's seat was in a properly maintained condition and was worn by Ms Zanetti. The seat belt on the passenger seat was unusable as one half of the belt had been removed for maintenance two days previously and had not been replaced. Mr Spicer reported this to the supervisor (as he was instructed during his induction) but was told by the supervisor "if you want the job get in the truck", consequently, Mr Spicer was unable to use the belt and did not do so.*

*At approximately 06.15 hours, Ms Zanetti drove the truck onto the stockpile, carrying a load of ore. The Proton truck controller instructed her to tip the load over the edge of the stockpile. This was the first load which she had tipped that morning. On the previous shift, ore had been removed from the base of the stockpile to feed the crusher. The edge of the stockpile was standing near-vertically and was in an unstable condition.*

*As Ms Zanetti reversed the truck to the edge of the stockpile to tip the load, the material collapsed under the rear wheels and the truck slipped over the edge and came to rest in upside down with the tray and cab resting on the ground some six metres below.*

*Ms Zanetti, who was wearing her seat belt, suffered shock and minor injuries; however, Mr Spicer, who was unable to wear his belt, sustained a fractured skull, three fractured ribs and a compound fracture of the radius and ulna of his right arm.*

The above provides the scenario. The Inspectors final report of the incident was used as the script to develop what animations were needed.

## **Reconstruction of Events**

All of the modelling and rendering for the reconstruct of this hypothetical scenario was undertaken using 3D Studio Max? version 3 and the software After Effects.

The animated reconstruction and the design of the training component was undertaken at the University of Nottingham (UoN). While this work was being undertaken at the UoN, Dr D Schofield was the SME for issues relating to mining and Mr J Noond was the SME for the training component.

The reconstruction and the training application were developed at the same time so as to allow both components to be presented at the MINESAFE 2000 International Conference as a joint paper involving the University of Nottingham (UoN), AIMS Solutions and Central TAFE. A full copy of the *Rolling Rocks* brochure can be seen as Appendix 14.

It is not intended to describe how the models for the reconstruction were constructed since the basis for the modelling is similar to that undertaken in case study 1 where the models were also constructed using 3D Studio Max from wire frames to solid models. The wire frames were then animated to illustrate each event. It is advantageous to do this prior to rendering, as rendering requires large amounts of processing time. Once the animated sequence is approved and the textures applied to each model the rendering process is undertaken. The following describes how some of the details were obtained and how the reconstruction was presented.

### ?? ***Mine details***

A scaled hand drawn plan (Figure 7-9) detailing survey points, and RL's (Relative Levels) was provided to indicate heights and position of relevant information. All this information was part of the normal briefing documentation in the training manual.

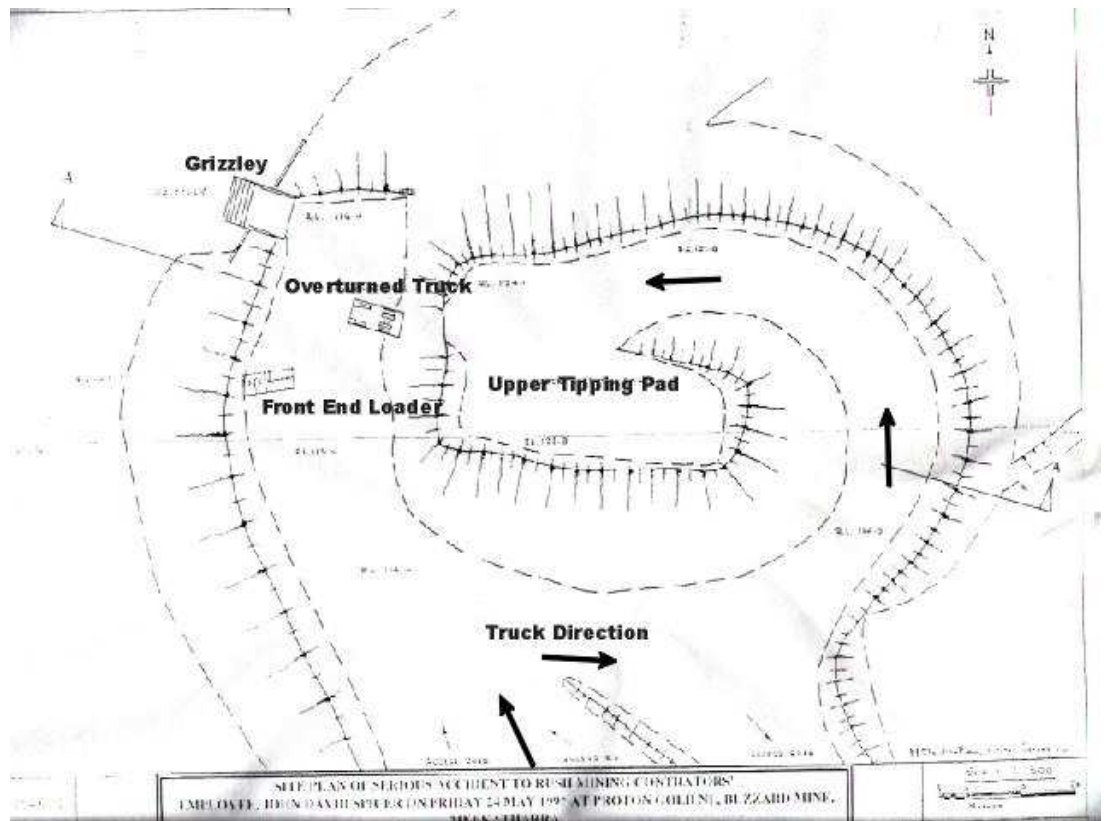

Figure 7-9: Site plane of where accident occurred

### ?? *Vehicle details*

The vehicle (Figure 7-10) used in this reconstruction is the truck used in case study 1, modelled using 3D Studio Max version 3 and initially developed and constructed by AIMS Research, UoN for their Safe-VR application.

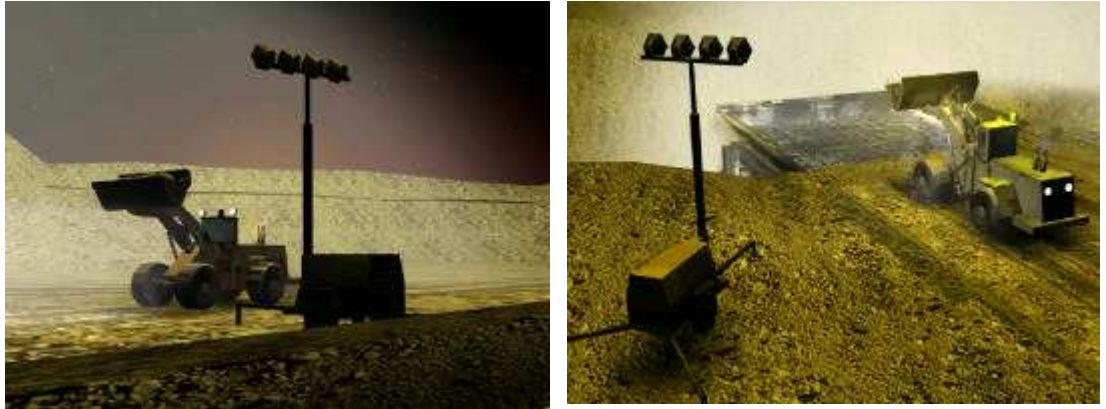

Figure 7-10: 3D truck model (AIMS Research)



## ?? **The reconstruction**

The reconstruction starts with the night shift (Figure 7-11) before the accident and shows the operation of the front-end loader on the stockpile. The removal of ore from below the stockpile caused the slope to be unstable.



**Figure 7-11: Night work**

The animation then moves to the next day, when the pre-shift truck inspection (Figure 7-12) is carried out. All vehicles must be inspected prior to use and any problems or issues must be reported to the supervisor on duty. This is when the missing seatbelt on the passenger seat was noticed and reported. The supervisor advised that if Mr Spicer wanted the job then he should carry on and get in to the truck.



**Figure 7-12: Pre-inspection of vehicle and missing seatbelt**

The animation (Figure 7-13) then shows the truck (with missing seatbelt) approaching the stockpile, climbing onto the stockpile's upper tipping pad and reversing to position the truck in preparation to dump its contents. There was no notification to indicate that ore had been removed from this slope on the previous

shift. The dump truck should have been told to go to a safe dump area so that a dozer could push the material into the area that needs to be re-enforced.



**Figure 7-13: Truck heading to stope and reversing ready to dump**

The animation continues (Figure 7-14) showing the truck reversing to the edge of the upper tipping pad and starting to raise the tray to dump its contents. It is from there that the ground displaces from the trucks rear wheels causing the truck to fall over the edge.



**Figure 7-14: Truck falling over edge**

The view presented is the front view demonstrating the truck tipping over. The reversal was not portrayed as it was unknown what part of the ground gave way and how the truck descended. It is important to remember that reconstructions are based on SME information and facts. If this information is not provided then it is not possible to reconstruct and accident accurately.

A photograph (Figure 7-15) of the final resting place is shown as this demonstrates how the truck actually ended up after falling 8 metres.





**Figure 7-15: Final resting place of vehicle**

## **Training Application**

The multi-media system developed for this particular scenario allows the user to investigate the accident by reading details of the mine (Figure 7-16) and witness statements and watching animated investigation on the equipment and surrounding areas.



**Figure 7-16: Location and aerial view of mine**

An example screen from the multi-media system is shown in figure 7-17. The system runs in a standard web browser and is easy to navigate. The user can access information about the minesite, mine vehicles and witness statements as well as animations and images showing what happened during the accident.



Figure 7-17: Screen captures of web-based application

The application could also be used to assist investigator training by providing the ‘personal touch’. That is, the witness statements although taken, are presented using photographs (Figure 7-18) of the witness. This gave a more realistic emphasis on the statements presented by these ‘characters’.

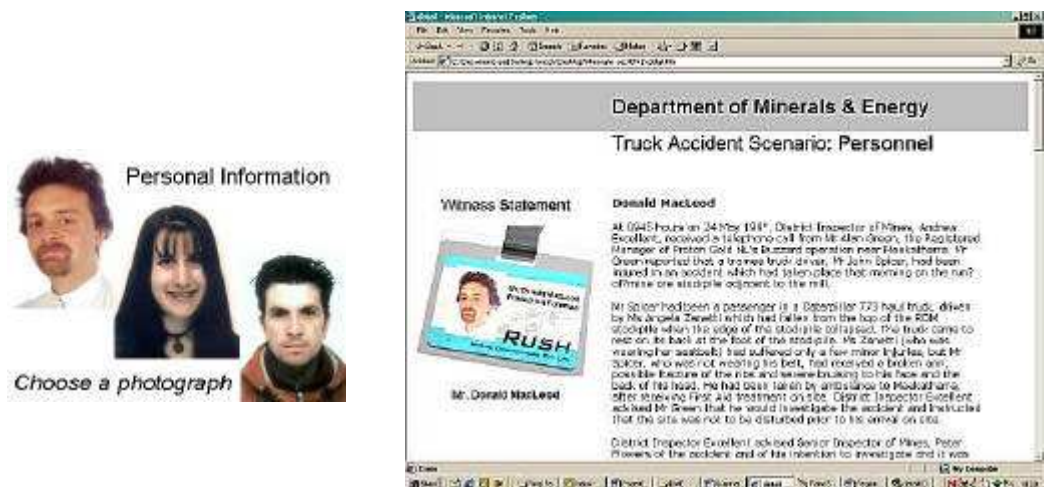

Figure 7-18: Personal information screen

Navigation through and around the application is done in a similar manner to other web-based applications using the ‘mouse’ to provide interaction. By positioning the mouse cursor over a ‘hotspot’ and clicking the mouse button (left one in this case) allowed the participant to move to the next screen or area that was chosen. As in figure 7-19 the hotspots were Home, Next, Back and the coloured bars with text.



**Figure 7-19: Navigation hotspots within the application**

The presentation concludes with the Inspector's Findings (Figure 7-20), which explains documents what the user of this application should have found or noticed, for example:

*The passenger side seatbelt on the truck driver by Mr Zanetti was not functional, as one half of it had been removed for maintenance two days prior to the accident.*



**Figure 7-20: Inspector findings**

This provides the novice inspector with correct identification of one of the causes of this incident, it also demonstrates how the information that is found should be noted and recorded.

The findings also suggest what areas of the Mines and Safety Act and Regulations have been breached and the Inspectors recommendation, which usually involves a prosecution or a formal letter from the DoIR.

## **Outcome of Reconstruction and Training Application**

The training application was demonstrated at the Minesafe 2000 International Conference held in Perth, Western Australia, 3-8 September 2000. There was no official response or formal assessment as to how the reconstruction was received by the 500 delegates. The best indication to its success was the reaction of conference participants when visiting the Central TAFE and the UoN combined exhibition stand demonstrating the use of CG&V at the conference.

The staff of the DoIR were very happy with the outcome. However until communication line speeds are improved and PC's are readily available at minesites such programs will have limited application. This does not stop the use internally by industry or for the safety people to conduct onsite or 'tool box' viewing.

### **7.1 Conclusion**

This case study demonstrated once again the value of CG&V in accident reconstruction. The visual 'story' demonstrated all the factors that contributed to the final accident of the truck tipping over the edge.

The use of web based technology also provides a mechanism for interacting with the case study as well as providing the ability of the application to be placed either on to a internet site or used locally via an intranet service.

The author wishes to acknowledge the assistance of Mr Martin Knee (State Mining Engineer) of DoIR for allowing the use of the case study as well other members of the MOD for additional information.

## 8 CASE STUDY 3 - EXPLORATION DRILLING

### Introduction

In July 1990, the Australian exploration world was talking of a new find near Mt Gibson Western Australia (north of Kalgoorlie). Karpa Spring was discovered by three prospectors - Clark Easterday and Len and Dean Ireland. Reverse circulation drilling scored some high-grade intersections, including 38m grading 34 grams per tonne. The deposit was said to have a strike length of 1,500m, open in all directions. Eight drill holes were shown as ending in mineralisation.

Tests on the samples revealed extremely high gold mineralisation and boosted the value of the Karpa Springs deposit which Perilya Mines N.L. bought with its Canadian based partner Noranda Inc for \$6 million in 1990. However, the check holes showed "*a complete absence of gold*", in the words of Perilya Mines NL and Noranda Exploration Pty Ltd, which promptly sued the original three prospectors for its \$6million and obtained court orders freezing the assets of the prospectors. On 28 February 1991 the prospectors were charged with fraud, the prosecution alleging that they had 'spiked' drill samples which had been sent to the assay laboratory. The trial started 31 May 1993 and ended 30 July 1993. They were convicted of the fraud and each served 13 months of a 3½ year jail terms (Kappelle, 2002).

To date the three prospectors still maintain their innocence and are appealing in the Western Australian Supreme Court on the grounds that the crown withheld scientific and share trading information at their trial, and that they have fresh evidence which would could have led to an acquittal (Kappelle, 2002). This scenario has been selected as a case study for a number of reasons:

- ?? It is a current issue, in that the reconstruction is to be used as part of an appeal process within the Supreme Court of Western Australia.
- ?? It is an mining incident that did not injure people or the environment nor require DoIR investigation, but it did fall in the area of a prosecution.
- ?? It will help demonstrate that reconstructions are a ideal tool for demonstrating procedures and practices in association with subject matter experts.

The most significant reason is demonstrated in the following statement by Mr Ken Steel, which is part of a letter (Appendix 15) explaining his involvement in the case and the reason why he thinks that a reconstruction would be useful.

*By the time I was called to give evidence at the trial, the case had been in session for several days and the jury had been provided with a mass of technical information to consider. In order to provide sufficient background information for the jury to support my evidence it was necessary to add to this and explain in detail the drilling process and its various complexities before I could hope to have them understand the core issues which my field trials had identified. The only method available to me was through a series of photo- copied diagrams and my verbal explanations.*

*As a personal observation I felt I was failing to get through to the jury being just one more in a long line of technical experts providing complex opinions information which would be totally alien to the average juror.*

*Cross examination demonstrated to me that my findings were not lost on the prosecution and they exploited the juror's probable failure to grasp the essentials of my findings as would be expected where the evidence was contradictory to their case.*

This case involves:

?? the use and understanding of 'Down The Hole' (DTH) hammer-drills

?? understanding geological structures such as 'zones of lost influence' and 'contamination zones'.

The reconstruction will be used in the Supreme Court of Western Australia - *Court of Criminal Appeal – Appeal No 111-113 of 1999*, as a tool to demonstrate a number of procedures relating to exploration drilling and the geological formations that the drill passes through. The completed reconstruction will be used in association with the SMEs (Mr M. McGowan and Mr K. Steele) who will also be using appropriate text and voice for further and more detailed information.

The MOD monitors the Western Australian exploration drilling industry under the Mines Safety and Inspection Act 1994. This case did not involve the DoIR as there was no accident or incident however, the prospectors were charged with

Fraud and Conspiracy to Defraud by the police on the advice from the Department of Public Prosecution.

## **The Case study**

A request was made to Central TAFE's CGVC by Mr Ken Steele a drilling industry consultant on the practicalities of assisting him and another (Mr Mike McGowan) in presenting their technical information using some form of computer graphics to ensure that the people associated with the appeal could get a better understanding of what the technical issues involved.

Following a number of meetings and demonstrations between Mr Steele and Mr McGowan, the SME's for this project and CGVC, it was agreed that computer graphics in the form of animations would assist greatly in the presentation of their evidence to the Appeals Court.

### **?? Case Scenario**

Mr Steele provided the information to indicate what the case was about, and his role in this appeal. The full details can be seen in Appendix 15, the following is a further extract from the letter.

*Drillmark Consultants was engaged by the defense and asked to examine all of the evidence and identify any possible explanations for the discrepancies, which had been accomplished in the exploration drilling process.....*

*The down hole hammer is essentially a high speed reciprocating piston running inside a cylinder and striking the drill or cutting tool several hundred times a minute.*

*Because of the close tolerances the down hole hammer system requires a specially formulated oil to be introduced into the air stream to lubricate the piston/inner cylinder surface. It was my preliminary opinion that this could have provided the means of introducing the salted gold.*

*I could find no evidence of this having been previously demonstrated but outlined the mechanisms and processes by which I felt this could be achieved.*

*The industry has three separate methods of introducing oil into the air*



*stream two of which employ a reservoir of oil to be mechanically collected through the air stream supply and the third being manually pouring oil into the system at each interval that the drill was stopped to extend the depth by adding another length of drill pipe.*

## **Reconstruction of Events**

All of the modelling and rendering associated with the reconstruction was done using 3D Studio Max? (rendering), Rhinoceros 2.0 (modelling) and After Effects (special effects) software.

The SME's were required to explain how various parts of an exploration drill rig and its drilling and collecting equipment worked. They were also responsible for deciding what information was required to be presented, as it was their evidence that was being reconstructed.

### **?? What is to be presented**

The SME's wanted to get across to the judges at the Court of Appeal the following:

?? What is Down The Hole Hammer (DTH) drilling ?

?? What is reverse circulation drilling ?

?? How does a cyclone work ?

?? What are zones of lost circulation ?

?? What are contamination zones ?

### **?? Down The-Hole hammer**

2D plans and brochures were obtained from various manufactures of DTH's so that a model of a DTH could be constructed. A schematic of a Secoroc DTH (Figure 8-1) was found on a website (Secoroc, n.d.). The schematic is animated on the website to show the DTH working.

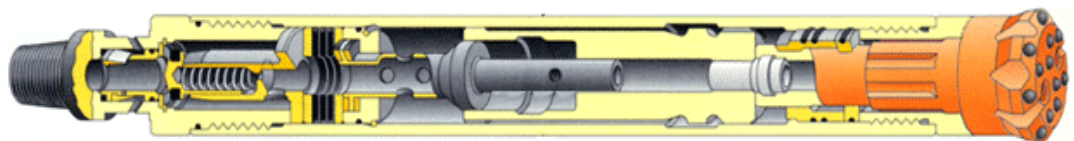

**Figure 8-1: SECOROC DTH Schematic**



A 3D model of a DTH was constructed using the modelling software. It was initially built as a wire frame model (Figure 8-2) with all parts that require movement developed separately. Low polygon modelling techniques were again used to ensure that the completed model was not too complicated for rendering and modifications.

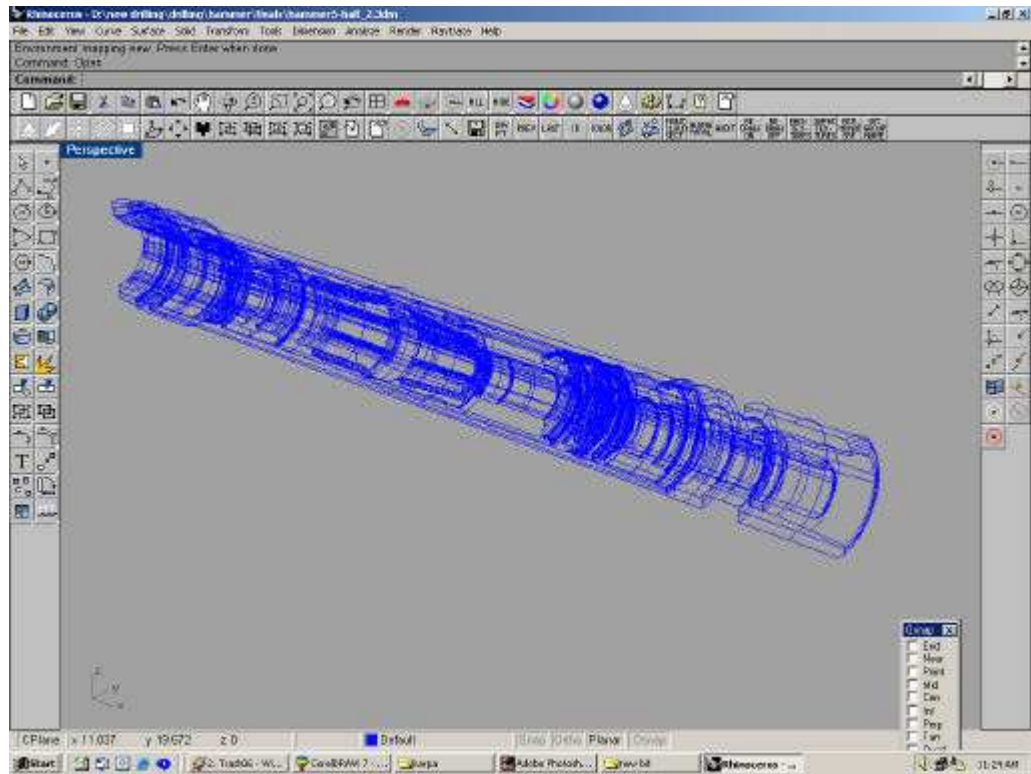

**Figure 8-2: Wireframe 3D model**

The author worked from various manufacturers brochures (Figure 8-3) and with the SME's to understand how a DTH worked.

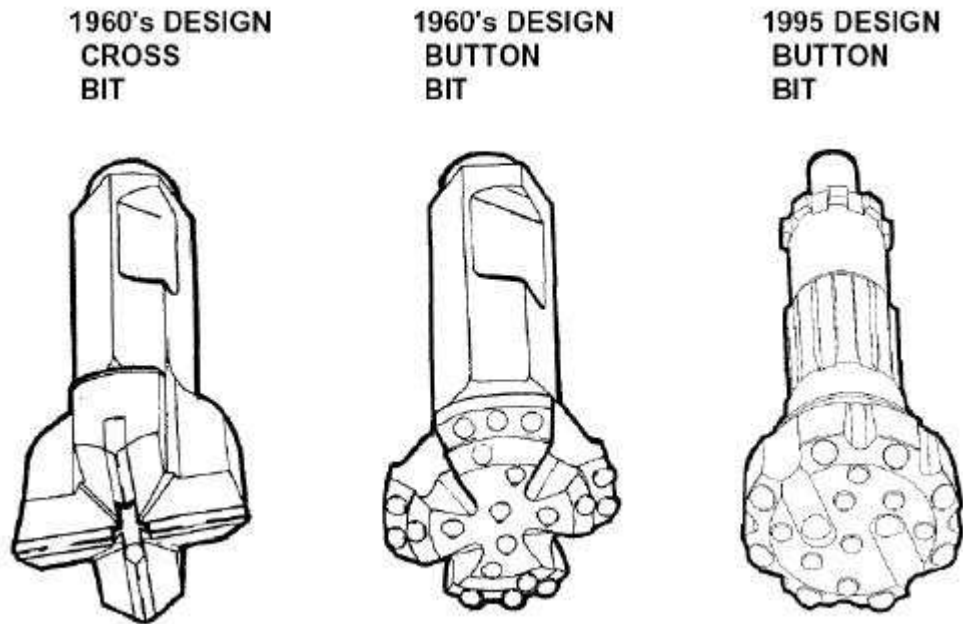

Figure 8-3: Types of drill bits (Halco, n.d.)

With all of this information the drill bit was developed (Figure 8-4) and this time rendered to allow the SME's to provide advice as to how they perceived the 3D model.

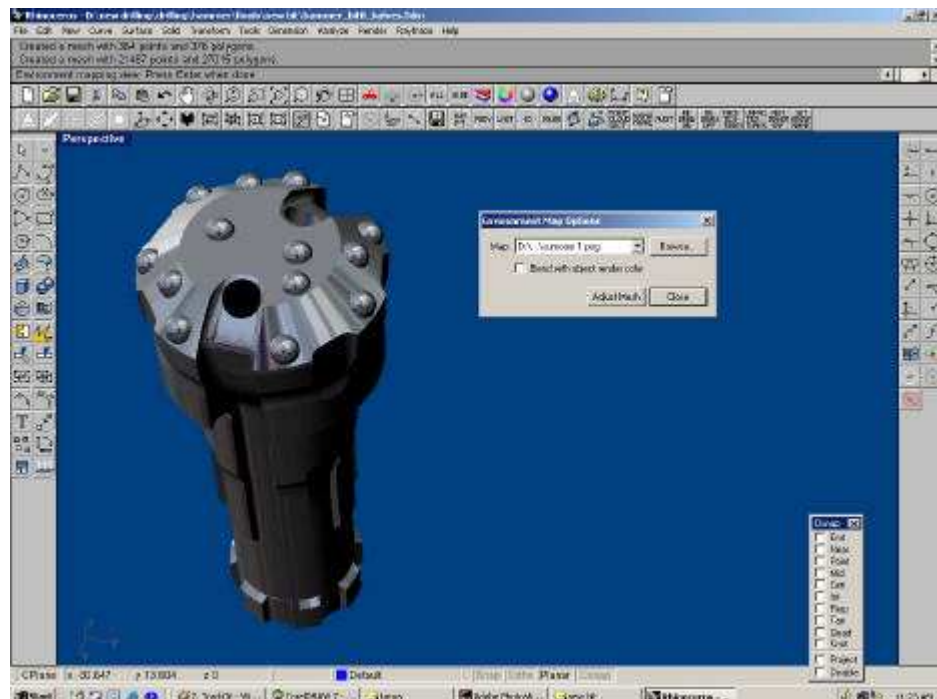

Figure 8-4: Rendered drill bit

Figure 8-5 demonstrates the drill bit and the DTH split, so that the internal moving parts could be viewed in motion as well as demonstrating how the air

circulates within the system. It was interesting to note that many industry representatives were impressed with the animated visuals, and some suggested minor changes to ensure better accuracy.



**Figure 8-5: Split view of rendered DTH**

Mr Greg Finch (2001) a senior industry expert after seeing the drill bit and DTH model, said the following:

*I have changed drill bits and fixed some parts but in my 30 years in the industry have never seen one that allows people to see all moving parts and air flows.*

### ?? **Reverse circulation drilling**

The reconstruction had to demonstrate how the air, which is pumped into the DTH flows, from the surface, through the DTH and drill bit and eventually ends up back at the surface and at the cyclone. This is demonstrated using traditional 2D diagrams in figure 8-6 and 8-7.

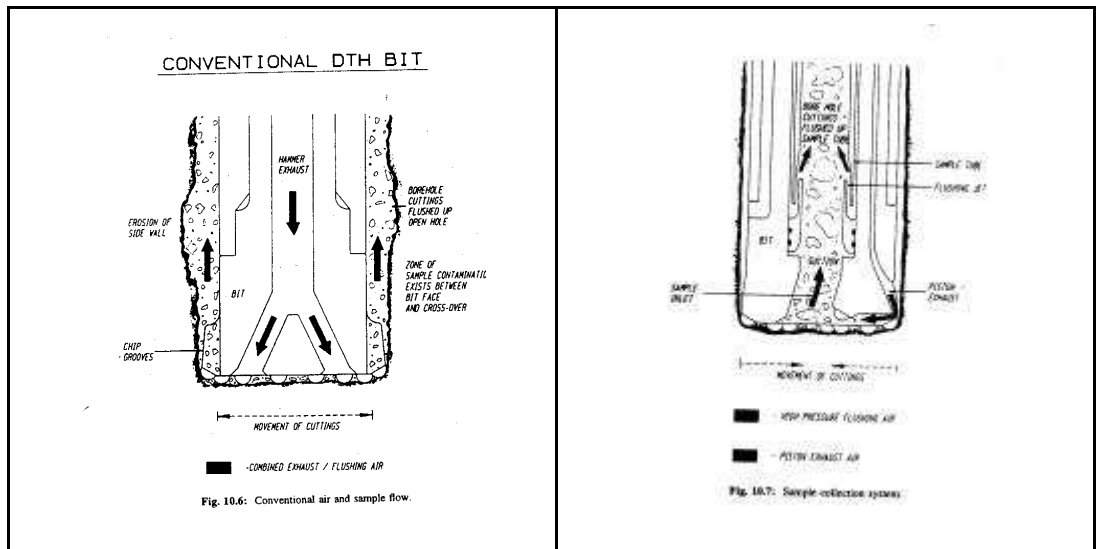

Figure 8-6: DTH Bit air and sample flow (Chugh et al, 1996)

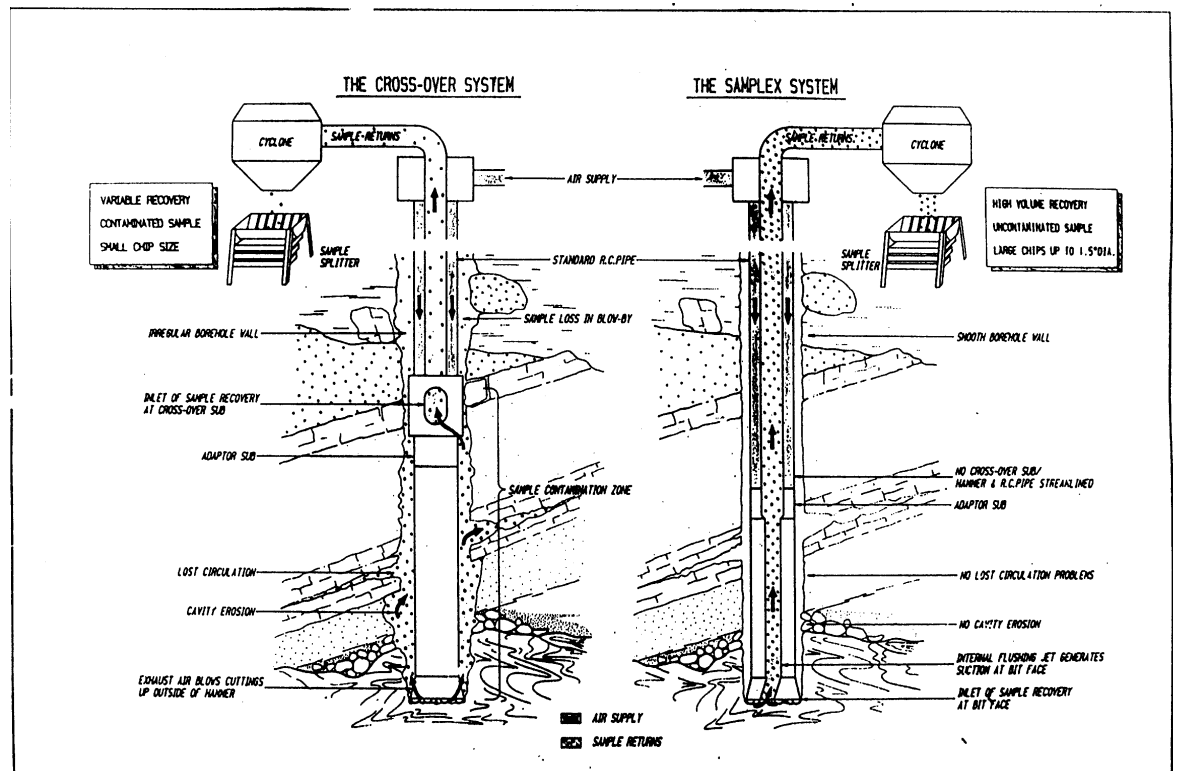

Figure 8-7: Airflow schematics (Chugh et al, 1996)

It is important that court personnel understand the process of the DTH and reverse circulation drilling. The following extract is from Mr Steele's requirements (Appendix 15).

*Central to my opinion was the specific type of drilling which had been employed and the equipment used in the process. This involved the use of a down hole hammer with a cross over sub using a drilling technique termed*

*RAB or rotary air blast drilling.*

*In this system the down hole hammer and the drill bit are powered by compressed air and used in tandem with dual wall drill pipe. To penetrate the subsurface geological formations and deliver samples of the ground being penetrated through the inner drill pipe back to the surface for collection and sampling....*

### ?? **Geological influences**

The reconstruction was required to demonstrate how differing geological structures could affect sampling and how the air pressure could contaminate (Figure 8-8) the surroundings.

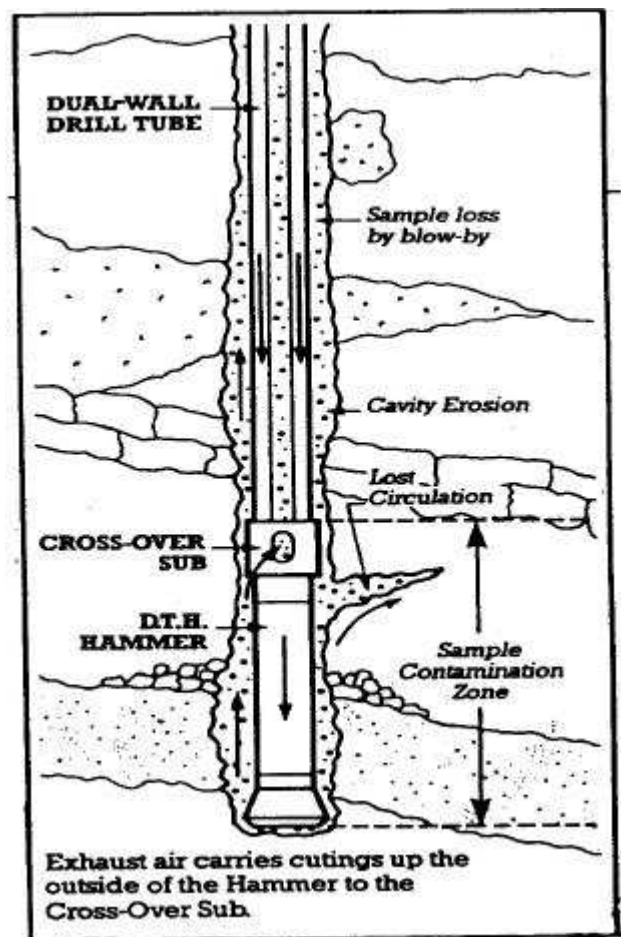

Figure 8-8: Geological influences (Chugh et al, 1996)

As the drill passes through the various geological formations in a hammering and rotating function the rock breaks and cracks. In addition the very high air pressure that is also passed down the hole via the drill tube also affects the surrounding

rock and the resulting erosion can contaminate the samples being passed back up to the surface. All of this information needs to be incorporated into the animation so that non-technical persons can understand the process.

From the above diagram and advice from the SME's a 3D model was generated (Figure 8-9) to demonstrate how the system operates and the factors that influences its performance.

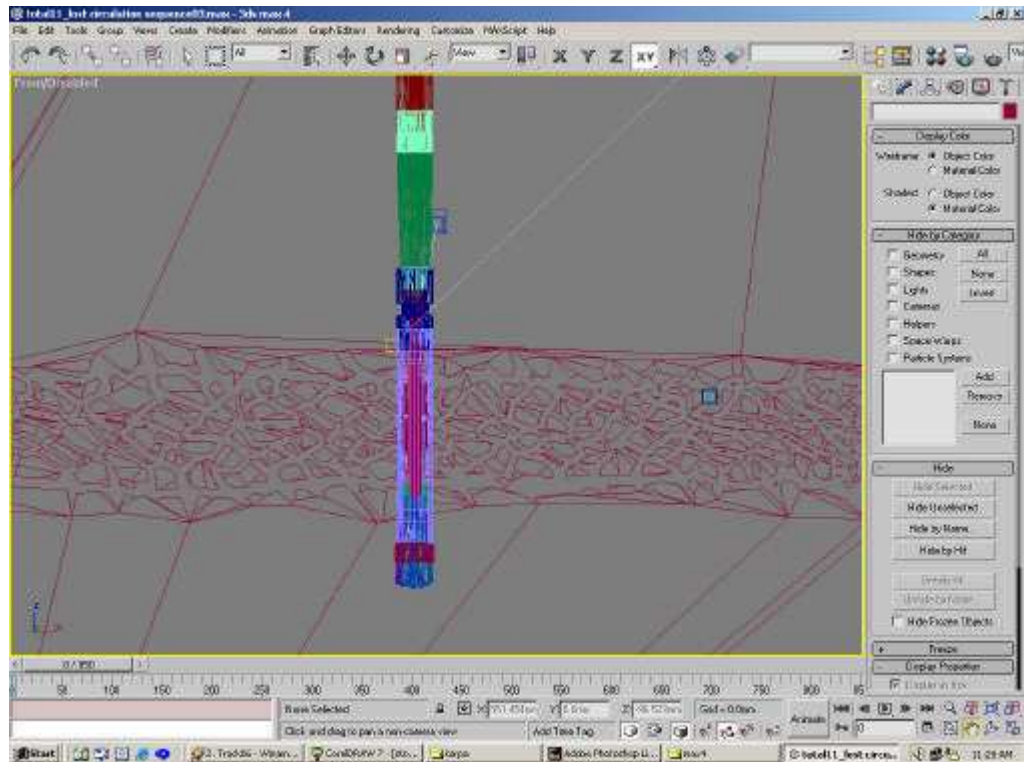

Figure 8-9: Wireframe model of geological influences

### ?? **Separation cyclone**

A cyclone was modelled from information provided by the Mr McGowan and also from models demonstrated on the internet. The cyclones presented in figure 8-10 was from Kerb Engineering (2002) .



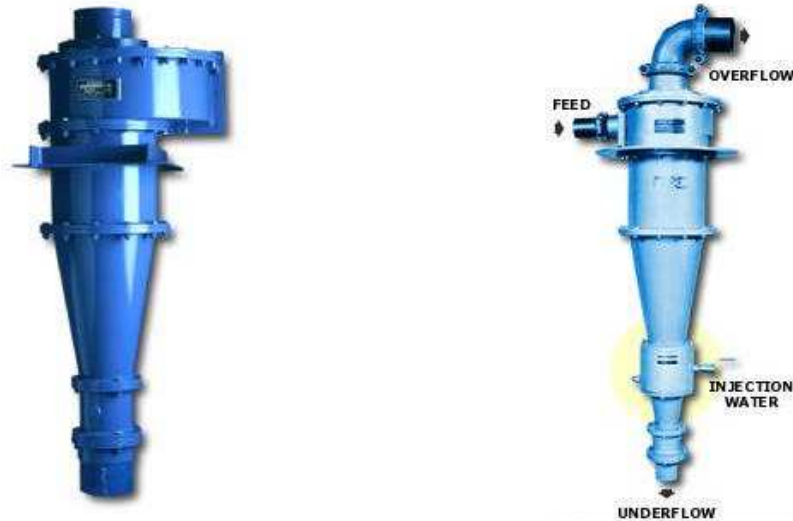

Figure 8-10: Cyclone

The rotation action inside a cyclone was also required to be demonstrated as this was one of the crucial elements within the evidence. Figure 8-11 from an article by Arterburn (n.d.) shows a sectional drawing of what is inside a cyclone as well as the rotational action of the fluid leading to the separation of the fine particles (*overflow*) and the remainder (*underflow*).

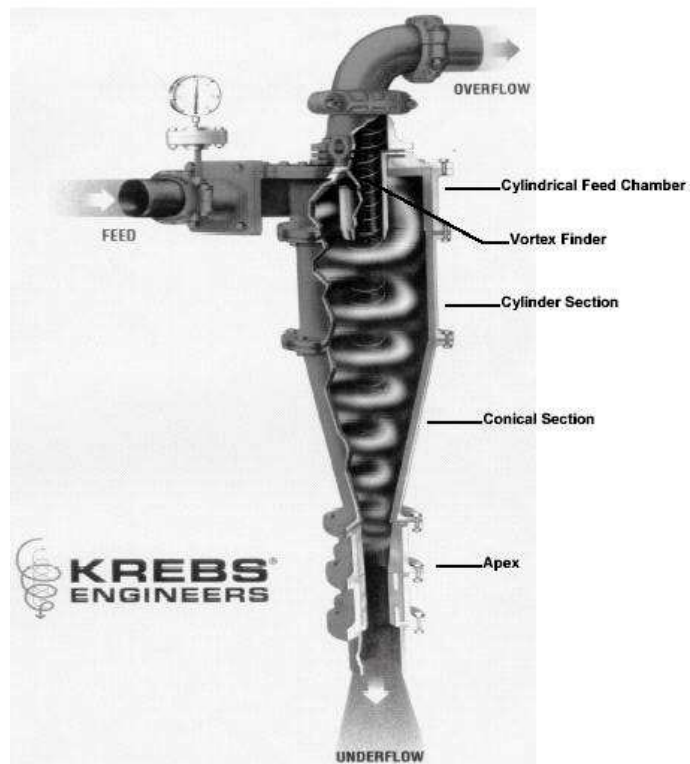

Figure 8-11: Model of cyclone

A cyclone was modelled (Figure 8-12) from all of the above information showing drilled dirt entering, separating and finally falling into a collection/sample bag.

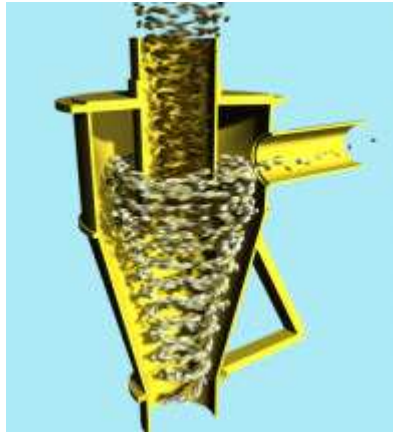

Figure 8-12: 3D model of cyclone

### ?? **Vehicle details**

The type of exploration drill rig was not an important issue for the court reconstruction so a general drilling rig was selected i.e. a UDR MarkII 650 (Appendix 16). A 3D model was constructed with limited detail so as to not distract the viewing audience (Figure 8-13) from the essential elements of the presentation.



Figure 8-13: Exploration drill - Courtesy UDR



## ?? **Assembling the events**

The reconstruction was completed with a number of computer generated animations showing various relevant information. These animations could be run as a single animated file or each animated event could be run independently.

The final decision was to have a single animated file with a voice over of what was being shown. The voice over was that of the SME.

A voice over script was prepared to match the animation, however the animations had to be re-rendered to ensure that the timing of the animation matched that of the voice over.

The following is an extract of the script, which was used for the voice over. The whole script is not available for publication in this thesis as it contains evidence that still resides with the court .

### **NORMAL SEQUENCE**

*In the normal sequence of events, a hole is drilled with a reverse cycle 'Down the hole' hammer drill.*

*Compressed air is pumped down from the surface inside the outer section of the drill tube, a double walled pipe with a thread on each end.*

*As the hole gets deeper, more sections of tube are added.*

*It continues through the tube until it reaches a unit called a crossover sub, where it is redirected into the centre section of the pipe. The air then travels through the hammer section of the drill, where it drives a reciprocating piston.*

*This piston in turn impacts against the actual drill bit, where the rock cutting process takes place. After the air has been through the piston chamber, it exits the hammer section through the centre of the drill bit....*

*This mixture of air and finely crushed rock is then redirected back through the crossover sub, and transported back to the surface through the inside of the drill tube... On reaching the surface, the mixture passes through a device called a cyclone air separator.*

*The airflow containing the mixture is forced to spin inside the cyclone. The*

*lighter dust is blown out the upper section of the cyclone and the heavier pieces of rock where any gold is usually found, fall out the bottom and are put into sample bags.*

### ***LOST CIRCULATION***

*Lost circulation occurs when the the drill bit encounters an area of rock that is either relatively porous, or has a fault or fissure through it.*

*As the bit passes through the Zone of lost circulation, the airflow, and suspended rock sample particles, spread out into the fissure, and some of the sample material is lost into the fissure.*

*The loss of containment also causes a drop in output air pressure and reduced sample material being transported back to the surface.....*

The following screen captures are presented to demonstrate that the animation was finalised, but due to the animation still being used and restricted to court viewing only a few of the screen captures have been included and not all are from the actual rendered models.

The animation opened with an overview of the exploration site to portray the environment (Figure 8-14) in which the incident occurred .

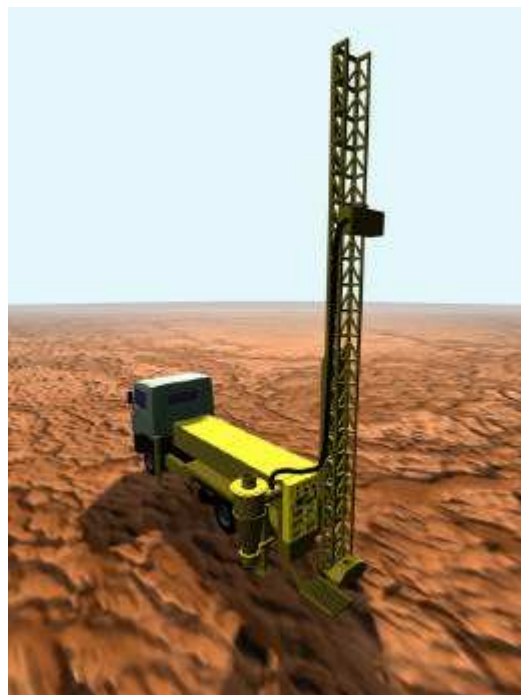

**Figure 8-14: Overview of environment**

A view from the top of the drill rig (*Header*) was demonstrated with the camera following the drill rod down. The camera then panned back to reveal a cross section of the ground so as to follow the DTH through the geological structures (Figure 8-15).

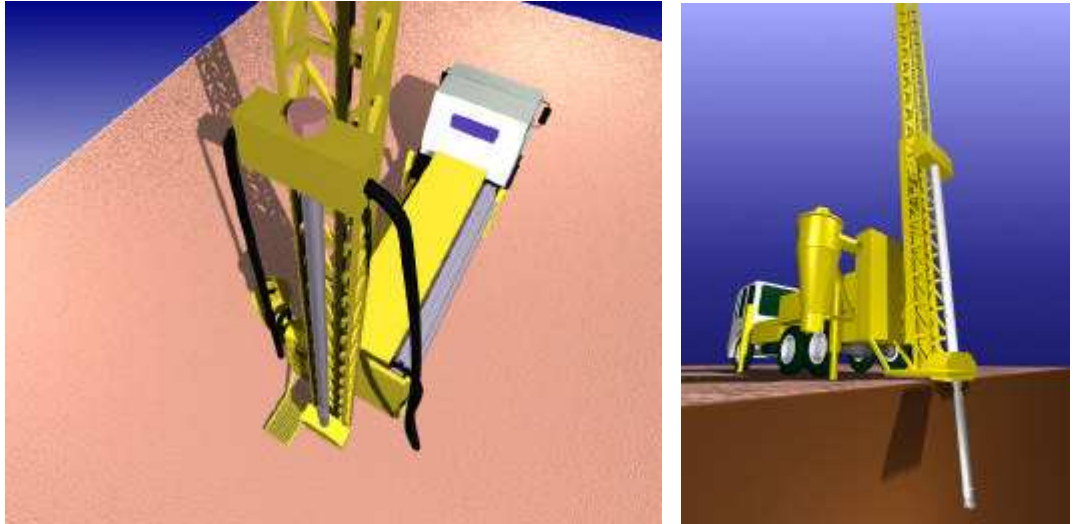

**Figure 8-15: Drill rig and sectional view of ground**

The camera followed the drill rod and DTH through the layers of geology and demonstrated the SME's evidence of 'lost circulation' and 'zones of influence'.

The next stage of the reconstruction was to demonstrate how the DTH actually drills through the rock formations and how the drilled particles are carried up to the surface. This was done by 'splitting' the DTH (Figure 8-16).

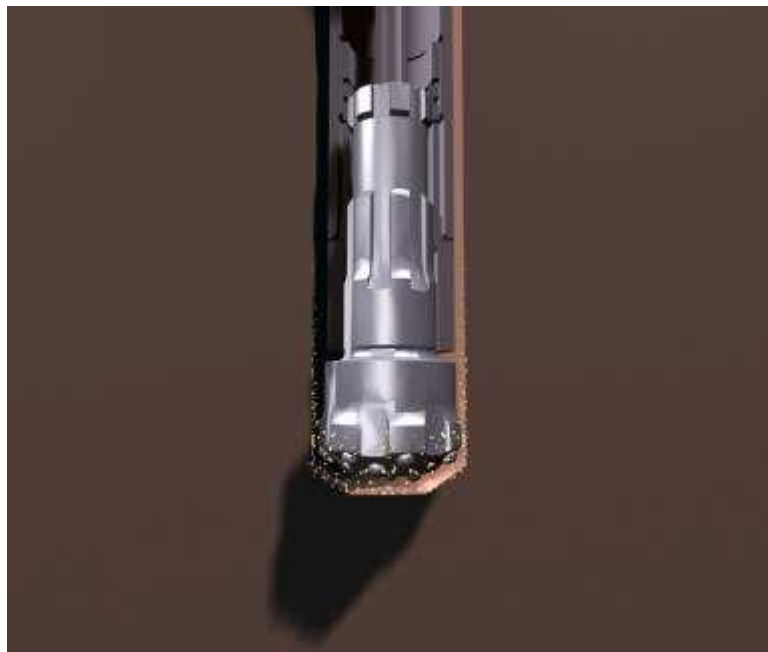

**Figure 8-16: Split DTH in ground**

The sectionalised DTH (Figure 8-17) was further animated to demonstrate the air flow that not only provides the air to the DTH hammer to make it work (like a piston) but also how the air transports the drilled rock particles through the DTH.

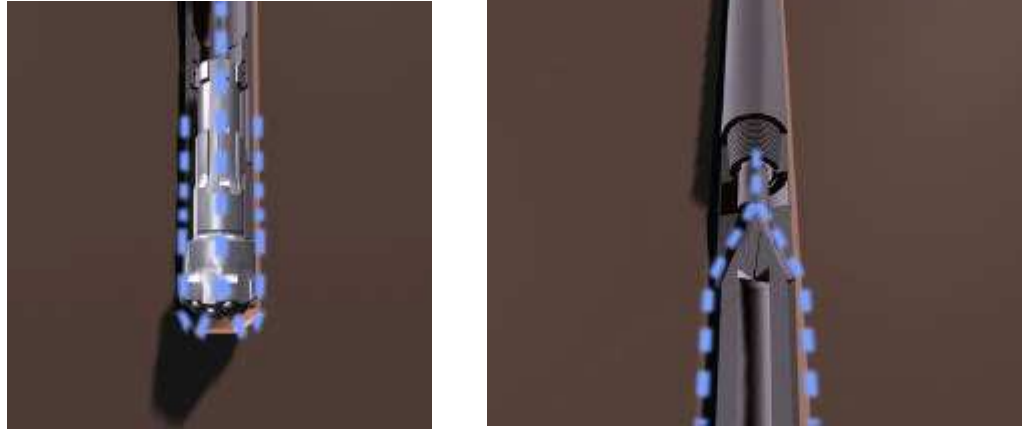

**Figure 8-17: Sectionalised DTH**

The final animation showed how the air with the rock particles made their way to the surface and into the cyclone, and how the cyclone circulated the rock particles and separated the light dust upwards to the overflow and the heavy particle downward to the underflow (Figure 8-18). The downward particles are collected in sample bags and some of these bags are taken for content analysis.

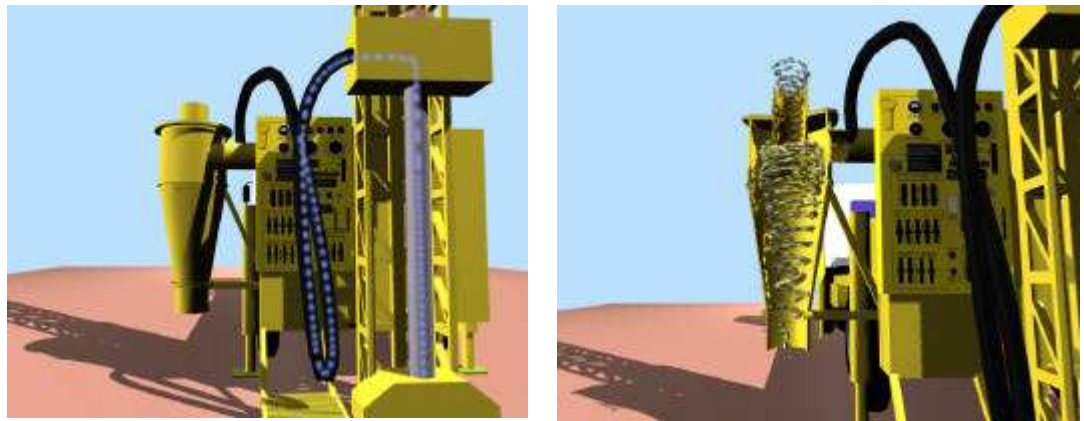

**Figure 8-18: Airflow to cyclone**

### **?? *Showing the completed reconstruction***

The Appeal was scheduled at the Supreme Court of Western Australia in late 2001 but deferments obtained by the prosecution kept the Appeal from being heard. The Appeal was finally heard starting on Monday 9<sup>th</sup> December 2002. The Supreme

Court of Western Australia – Court of Criminal Appeal – Easterday<sup>8</sup>, Ireland<sup>9</sup> and Ireland<sup>10</sup>, was held before Hon Justice Scott, Hon Justice Steytler and Hon Justice Robert-Smith. The Appeal was set to finish on 20<sup>th</sup> December 2002.

The reconstruction had been completed with a number of computer-generated animations presenting specific information requested by the SMEs. The animations were set out to be presented in association with the SME's testimony. Additionally, the SME's inserted video footage of specific actions that did not require animating as the evidence was demonstrating work practice and methods.

The final product presented to the court was an eleven minute video. The video contained the animation with the voice over of the SMEs as well as actual video footage of an exploration drill rig demonstrating what the SME's had testified to was possible.

The following is a statement from Michael McGowan (2003) who was one of the SME's using the video

*The video presentation was the first part of my evidence presented to the court. The video was played as I was in the box.....*

*...after being sworn in and verifying that I was the author of the affidavits and one of the joint authors of the video and the video was part of my expert evidence, the video was presented to the court.*

*The judges immediately understood what my evidence was about, and were able to, and did ask intelligent pointed questions about aspects of the expert evidence. That gave me the opportunity to explain aspects of the evidence that otherwise would have been difficult to articulate.*

Hence it is apparent that the video was also used in conjunction with the SME's testimony to demonstrate in a graphical manner what they were talking about.

Michael McGowan (2003) continued:

---

<sup>8</sup> CCA/111/99 – Easterday

<sup>9</sup> CCA/112/99 – Ireland

<sup>10</sup> CCA/113/99 – Ireland

*Our counsel said that those 11 minutes were the most powerful and most easily understood part of all of the expert evidence. It helped make all of the rest of our expert evidence understandable also. I think the judges completely accepted our proposition as to how the salting took place. We will need to wait for their decision to be sure of that. The animation was important, as was the video of the rig operation. The voiceover worked a treat.*

During the summing up from the defence lawyer Mr T Percy QC, it was mentioned that during the examination of a SME (Mr M McGowan) that the video that accompanied his testimony was very beneficial in informing on what is 'lost circulation'. He also informed the judges during his summation that at no time was the information presented on the video challenged by the prosecuting team.

### ?? **Outcome of reconstruction**

In a paper by Patricia Kuehn, (1999) titled '*Maximizing Your Persuasiveness: Effective Computer Generated Exhibits*' she makes the following statement

*A two-minute video, if well made, will make a greater impression on the minds and emotions of jurors than the world's best expert. Once jurors see the video, the images will be graven on their mind... The familiar power of television will shoulder everything else aside. The very value of using the videotape — its ability to impress and explain — is thus the source of the most persuasive arguments against its use.*

The outcome is not only the acceptance of the reconstruction by the courts but the acceptance by the industry to use animation as a tool to explain technical processes.

This reconstruction was requested by two industry experts to help them present their technical information, and from the comments by Mr Steele (Appendix 15), reconstructions are useful.

*The use of computer graphics which animate the drilling process and enable the inter related and interactive aspects of the drilling process and sample delivery to be visually demonstrated will greatly enhance the ability of the judiciary to grasp the complexities involved and follow the logic on which my part of the evidence is based.*

*In this format the drilling equipment, the system and the interference with the formation can be illustrated and interrogated to ensure total comprehension and conformity with the original findings presented at the initial trial.*

*My involvement with the development of this animation has heightened my awareness of the potential power of this technology in the wider field of training in general.*

On Friday 28 March 2003 at 9:15am the WA Supreme Court of Appeals presented their findings on the Karpa Springs case. The three judges were unanimous that the 3 men were innocent on all charges and that their decision was final with no further appeal.

It is unclear at this time if the CG&V is mentioned in the judges decision reports as they were not released. The reports contained information that was said 'in-camera' and pending possible further legal action, the report will not be released so as to not prejudice other potential outcomes.

## **Training Application**

A training version of this scenario is to be used by Central TAFE and industry, showing how a Central and External DTH Hammer works, both their internal workings and airflow circulation. It is also possible that the animations could be added to existing training applications such as AIMS research's application SAFE-VR Drill Rig or eventually as an individual web based application for on-line training and possible maintenance application.

For the purpose of this project the application has been setup as a straight AVI file that the user selects (using the mouse button) and the animation will run and the user will be presented with the selected animation plus a voice over describing the animation. This is aimed as a Tool-Box presentation or for more general drilling industry use.

### **?? Development of the application**

This was achieved by taking the original reconstruction and putting in placing a new voice over to explain, in some part, the more technical items as this was to be

used by the drilling industry who all ready have some knowledge of the components.

### ?? **Outcome of application**

*Until the court has released the evidence the application cannot be released for general viewing or comments. The benefits can only be assessed by Mr Steele and Mr McGowan who commissioned this reconstruction with a view of allowing a training component to be extracted from the reconstruction.*

The following statement from Mr Steele's letter (Appendix 15) demonstrates that this application and ones like it are very useful.

*In its current form apart from its use in the court room, the functionality of the animation lends itself to explaining to trainees and indeed current practitioners of precisely what happens down the hole whilst conducting exploration drilling activities and how the various pieces of equipment such as down hole hammers, cross over subs, dual wall drill pipes and cyclones operate and interact to perform their individual functions.*

*From the industries perspective it is far better to have drill crews trained with more universal skill sets and the use of the computer graphics lends itself to this.*

*The concept of using this animation and others like it linked into a drilling rig control panel could present a training aid with substantial application in the field of training and one which industry would embrace with enthusiasm were it to be commercially available.*

## **Conclusion**

This case study of a 'real life' incident demonstrated that there are many more factors to take into consideration than the hypothetical studies. This case study was to be used to assist in obtaining freedom for people. This case study although developed and ready to be presented was postponed which provided the team to do some modifications and this occurred a number of times.

The outcome achieved by the development and presentation of the graphics to a Supreme Court in Western Australia and the very positive comments from the Mr McGowan and Steele before and after the video was presented as 'evidence'



continues to demonstrate that the use of CG&V as a reconstruction and training tool is very much accepted by experts and required by industry.

## **9 CASE STUDY 4 – OFFSHORE OIL SPILLAGE**

### **Introduction**

The basis for the modern health and safety legislation has its roots in Lord Robens' 1972 report on Safety and Health at Work in the UK. The findings of the Robens report were embraced in the UK Health and Safety at Work Act of 1974. However it was not until some 14 years later as a result of the Piper Alpha disaster in the UK North Sea in July of 1988 and the subsequent Cullen public inquiry, that the objective setting legislation (espoused by Lord Robens) was seriously considered in the offshore petroleum industry (Ihdayhid, 2000). In Western Australia, the Robens philosophy resulted in the development of the Occupational Health Safety and Welfare Act 1984, now known as the Occupational Safety and Health Act 1984 (Ihdayhid, 2000).

It has been over 10 years since the Piper Alpha Disaster in the UK North Sea. The inquiry into this incident initiated the move away from prescriptive legislation, to a co-regulatory objective based approach to safety management in the upstream petroleum industry. The 'safety case' legislative regime (Appendix 17) was adopted in Australia, and became effective from 1 July 1992 for new production facilities, and from 1 July 1996 for existing production facilities and MODUs (Mobile Offshore Drilling Units). Major developments in legislation have been occurring over the past years to streamline the regulatory system and to make it consistent with a co-regulatory objective based approach.

The term 'safety case' is used to describe a sophisticated, comprehensive and integrated risk management system. A safety case regime is characterised by an acceptance that the direct responsibility for the ongoing management of safety is the responsibility of the operators and not the regulator, whose key function is to provide guidance as to how the safety objectives to be achieved. The operators can achieve those objectives by developing systems and procedures that best suit their needs with the co-operation and agreement of the regulator. This 'safety case' then defines the rules by which the operation of the facility is governed (DoITR, 2003).

The DoIR administers the Commonwealth offshore adjacent area under a Joint Authority arrangement as the Designated Authority. The DoIR collects information relating to safety performance in Western Australia, but sends it to the Australian Petroleum Production & Exploration Association (APPEA). The APPEA is the national organisation representing the oil and gas exploration and production industry in Australia. The Association seeks to promote a competitive basis for the development of Australia's oil and gas resources while maintaining the highest standards of environmental management and safety. Members of the Association account for more than 95 percent of oil and gas producers in Australia (APPEA, 2000).

The following diagrams (Figure 9-1 and 9-2) from the APPEA Report (2000) demonstrate that there are not as many reportable injuries in the oil and gas sectors as is the case in minerals sector due mainly to the difference in the size of the workforces. It is also significant that there has been a steady decline in the oil and gas sectors (as in the minerals sector) injury frequency rates over the years.

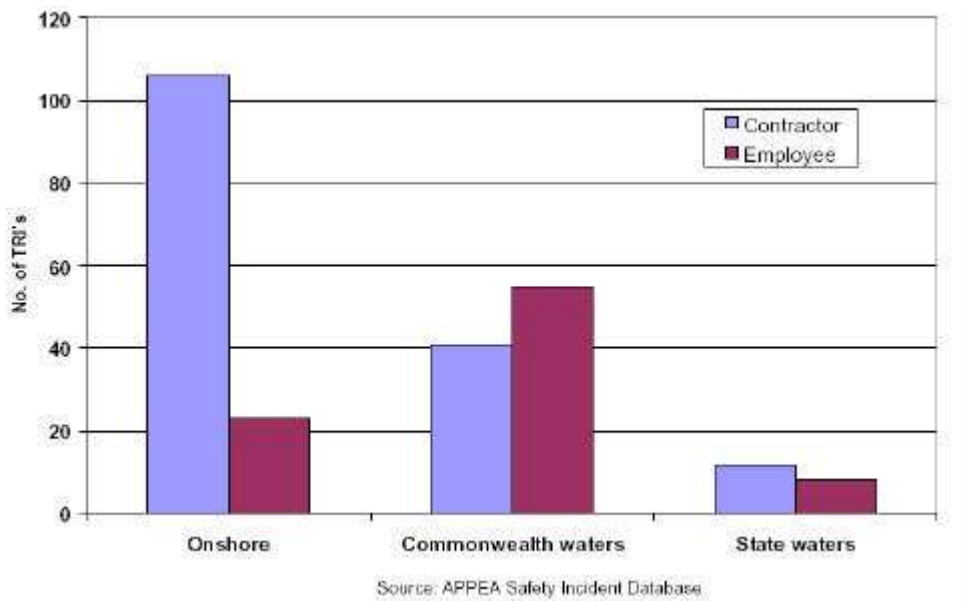

**Figure 9-1: Total reportable injuries by jurisdiction in 2000**

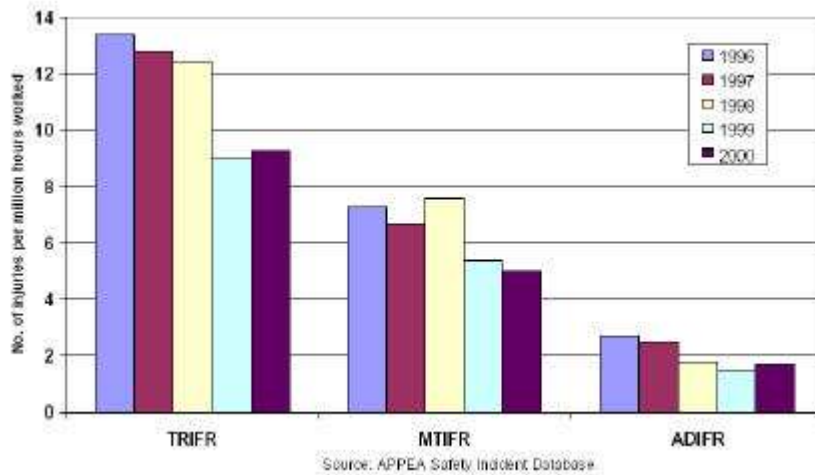

**Figure 9-2: Medical treatment and alternative duties injury frequency rates 1996-2000**

There were zero fatalities in the Australian oil and gas exploration and production industry in 1999 and 2000, compared to 3 in 1998, 6 in 1997 and 1 in 1996. Consequently, the fatality frequency rate (or fatal accident rate) was also zero in 2000 and 1999, compared with 0.1 fatalities per million hours worked in 1998, 0.2 in 1997 and 0.04 in 1996 (APPEA, 2000). Definitions of how these rates are calculated are shown in Appendix 18.

The following chart (Figure 9-3) demonstrates the petroleum fatality frequency rates in relation to other industries.

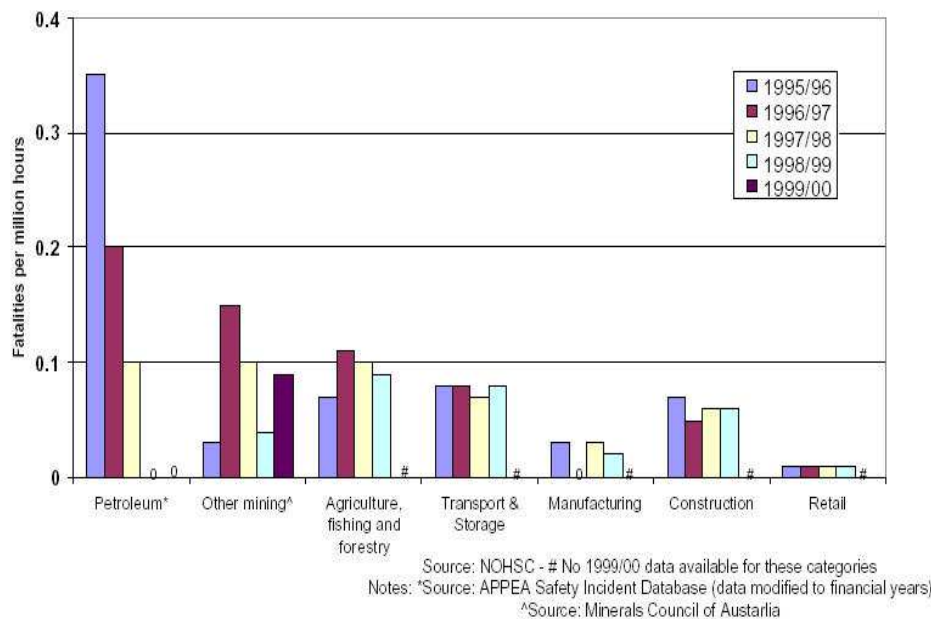

**Figure 9-3: Industry fatality frequency rate 1995-2000 (APPEA, 2000)**

The last WA oil and gas sector fatality was recorded in March 1996 and this occurred within the onshore industry. The WA offshore industry recorded its last fatality in July 1994.

As with the minerals sector the Petroleum Division within the DoIR collects information and distributes that information to ensure that the petroleum and gas sectors are aware of various incidents and relevant safety information.

As demonstrated in Chapter 2, section 9.1. a number of training and educational methods are used to enforce current trends and present pertinent information to the industry. The industry and the DoIR take all accidents and incident very seriously no matter what their size, as shown in the following case study where a small spillage occurred but was still deemed to be a prosecutable offence.

### **Spillage Case Study**

Against the backdrop of these accident figures, the following case study is an actual incident that occurred in the waters off the coast of Western Australian. The company involved was prosecuted but settled out of court.

The usage of this incident as a case study for this research was agreed providing the company and those involved were not identified. The case study involves an underwater incident where a subsea hose, that transfers crude oil stored on land, to ship oil tankers, is damaged during the process of transferring and releases (spillage) oil into the sea.

Spillages are a reportable offence as demonstrated in the following extract of the Petroleum Act (Petweb, 2000).

*The reporting of incidents resulting in the spillage or escape of hydrocarbons or other contaminants from onshore operations is regulated under Clause 290 of the Petroleum Act 1967 Schedule of Onshore Petroleum Exploration and Production Requirements 1991 (the Onshore Schedule; Table 1). Under Clause 290 (1), a report to the DME [DoIR] must be made in the event of:*

?? a significant spillage of hydrocarbons which in areas of inland waters is in excess of 80 litres and in other areas in excess of 500 litres

?? a significant quantity of petroleum in a gaseous form is in excess of 500 m<sup>3</sup>

Clause 290 (2) of the Onshore Schedule states the requirements of a written report to the Director of the DME [DoIR] at the same standard as those of Clause 285 (2) of the Offshore Schedule (stated above).

For offshore operations under State jurisdiction, Clause 285 (1) in the Offshore Schedule stipulates reporting requirements in the event of:

?? an escape or discharge into the sea of a mixture of petroleum and water in which the petroleum concentration was greater than 50 mgL<sup>-1</sup>;

?? an escape or discharge into the sea of more than 80 L of petroleum.

### ?? **Incident Description**

The incident occurred at Island Marine Terminal, in State waters. The terminal is 100km off the coast from Dampier, Western Australia (Figure 9-4).

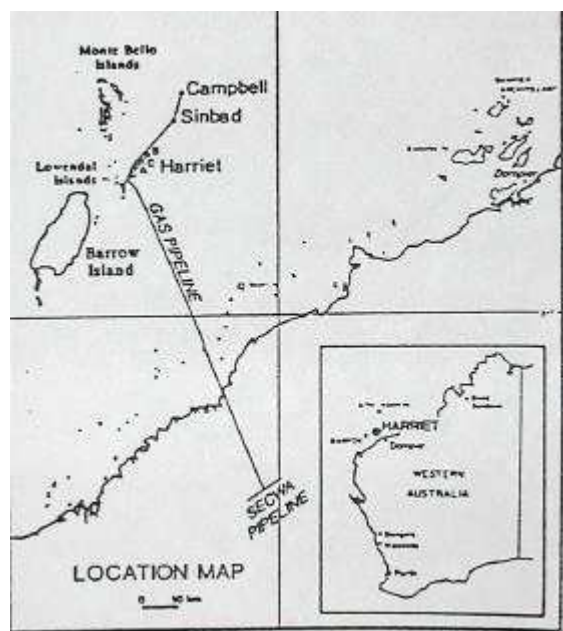
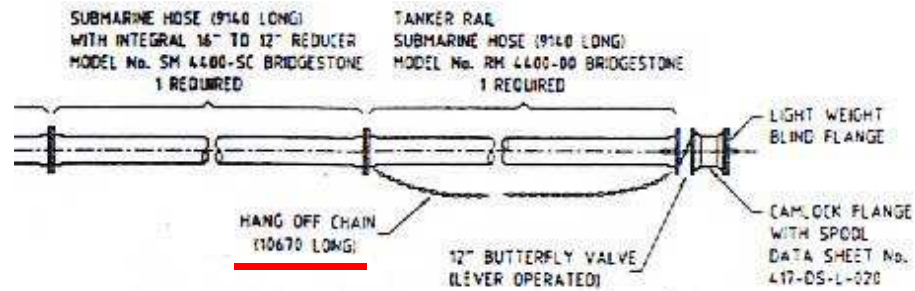

Figure 9-4: Location map

At the terminal unprocessed oil that has been extracted by nearby oil-wells. The capacity of the terminal requires that an oil tanker collects a shipment every 10-15 days to ensure that the terminal can keep receiving fresh oil from the oil-wells. The crew of tanker M/V SHIP-1 was on a trip to collect the oil and to do this they were required to connect to the terminal using the subsea loading hose.

As the tanker was in the process of receiving the subsea hose from the tender vessel, an object (later found to be a 4 inch subsea purge valve) was accidentally pulled to the surface. The purge valve was entangled in the 'hang-off-chain' that

is connected at the front of the subsea hose. The hang-off-chain as shown in figure 9-5 is 10-12 metres in length and is connected to an onboard crane to lift the subsea hose onto the tankers deck so that the crew can connect the hose (via its flange) to the receiving tanks on the ship so that the stored oil from the terminal can start flowing.



**Figure 9-5: Hang-off-chain**

The purge valve was located 73 metres back from the flexible hose end close to the 16 inch Pipeline End Manifold (PLEM) valve (Figure 9-6). The PLEM is the interface between the fixed location pipe and the flexible subsea hose pipeline. The ‘traumatic’ shearing off of the purge valve resulted in a loss of approximately 30 m<sup>3</sup> of crude oil causing a slick some 4 nautical miles in length.

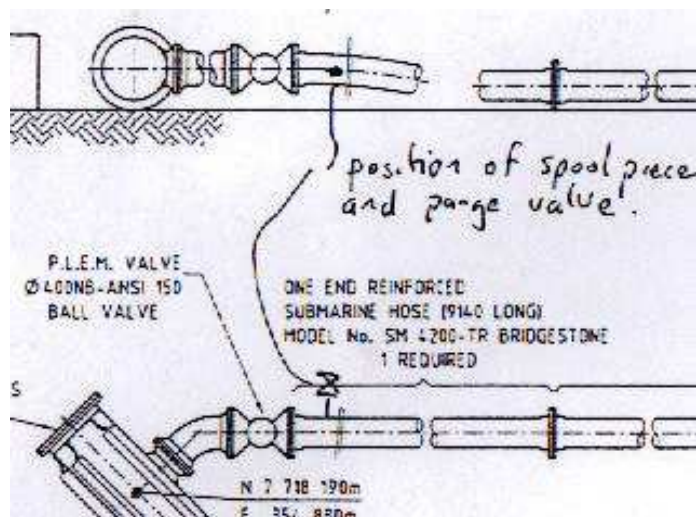

**Figure 9-6: Purge valve plan**

The investigation identified that the immediate cause of the incident was believed to be the ‘hang-off-chain’ which had become snagged around the purge valve. It is further believed that the tanker’s safety officer failed to appreciate during the hose retrieval operations that parts of the chain had become snagged.

The DoIR's PD following their initial investigations invited Central TAFE's CG&V Centre to assist in determining what could have occurred by the use of 'what-if' scenarios and the animation of a number of witness statements. The reconstructions had to be accurate as they were to be used in legal presentations to demonstrate what the DoIR investigators believed happened and also to demonstrate the sequence of the events as described by the witnesses.

## Reconstruction of Events

All of the modelling and rendering for the reconstruction was done using 3D Studio Max? version 3. Witness reports were used and advice was sought from the SMEs.

### ?? **Valve and hose details**

A 2D plan (Figure 9-7) was provided detailing subsea hose measurements, layout and fittings. This was used to certify the accuracy of maximum distance between the PLEM Buoy and Marker Buoy, and the number of subsea hoses between these two Buoys.

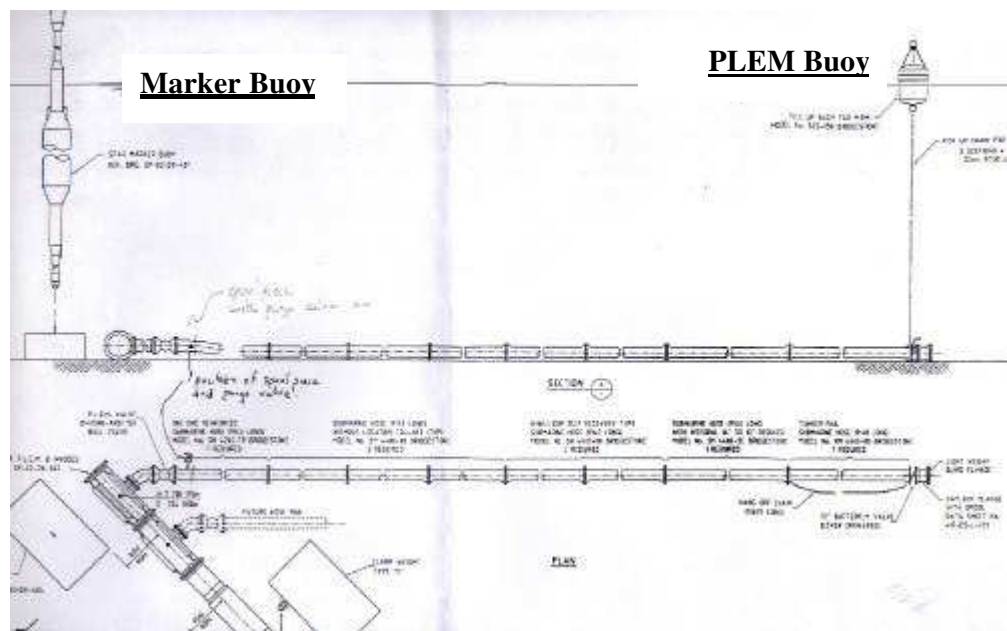

Figure 9-7: Subsea hose diagram/plan

Another 2D plan was provided (Appendix 19) which demonstrated where the purge valve was positioned. The reason for the hand drawn notes on the plan was that the purge valve had been added later and the plans had not been updated.



The use of photographs of the recovered, damaged items (Figure 9-8) was also beneficial in establishing what was to be produced, although there was no scaling item (e.g. a ruler) placed next to the items to enable a scaled measurement to be obtained.



**Figure 9-8: Damaged valves**

### ?? ***Tanker details***

The actual details of the tanker and attending vessel (Figure 9-9) were deemed not to be significant so approximations of the tanker and attending vessel were used. The attending vessel retrieved the PLEM Buoy, which is connected to the hose connector, and hooks it to the tanker for its crane to hoist up the subsea hose.

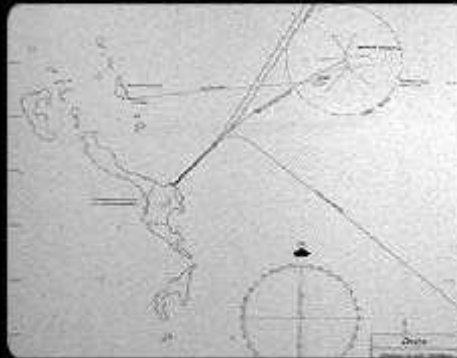

**Figure 9-9: Tender vessel and tanker**

### ?? ***Storyboarding the events***

A storyboard was constructed to demonstrate what models were to be developed and to ensure that the animation would represent what had happened. A 3D model of the environment was constructed and the accuracy of measurement was not deemed to be an issue as the model was to be used only for demonstration purposes, identifying items of relevance and for producing a final storyboard

(Figure 9-10) to illustrate each event as mentioned by the witnesses, SMEs and DoIR Investigators. Documented information was placed under the relevant graphics to explain what was being portrayed.



1 On Monday the 28th the second attempt was made to berth the tanker. This takes place at a preset mooring area, and involves the tanker attaching to 8 anchors in 20m of water.

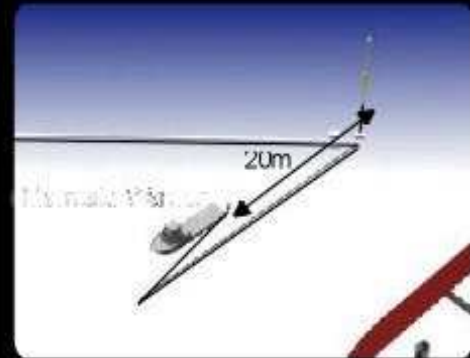

4 The workboat picked up the hose end marker buoy. N (skipper) stated that the pickup buoy was approx 20m south of the PLEM marker buoy.



2 The tanker was moored with its bow to the south, with the current running south to north/northwest. The transfer hose is a 70m long flexible rubber hose, fixed to a concrete mooring.

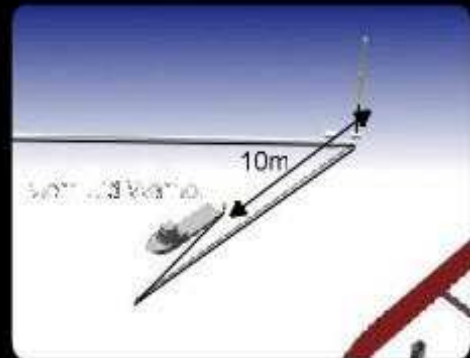

5 The usual distance between the buoys is 40-50m. Seaman E stated that the distance between the buoys was only 10m.

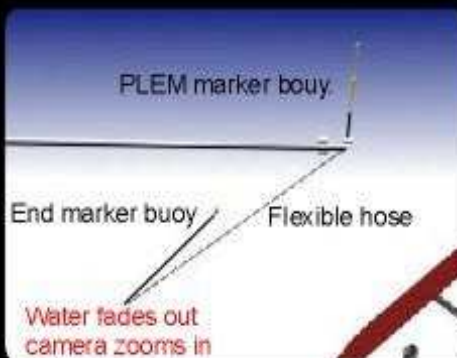

3 The tanker is moored alongside (parallel) to the flexible hose. The fixed end of the hose is marked by a 15m high PLEM marker buoy. The end to be lifted is marked by a small yellow buoy.

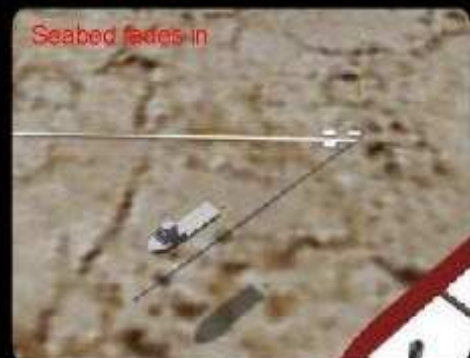

6 We believe this discrepancy in estimated distance can be the result of the flexible being out of position.

Figure 9-10: Storyboard for setting the scene

## ?? **Assembling the events**

There were three areas that needed to be addressed in the reconstruction of this incident:

?? What happened before the tender boat picked up the PLEM Buoy? This included prior events such as weather conditions and procedures for releasing the hose after use.

?? What procedures were followed while collecting the hose and who saw what?

?? What technical and non-technical items need to be used and mentioned throughout the reconstruction? For example, where are the PLEM and Marker Buoys? This is demonstrated as a wireframe in figure 9-11, however in the final presentation the environment would be rendered.

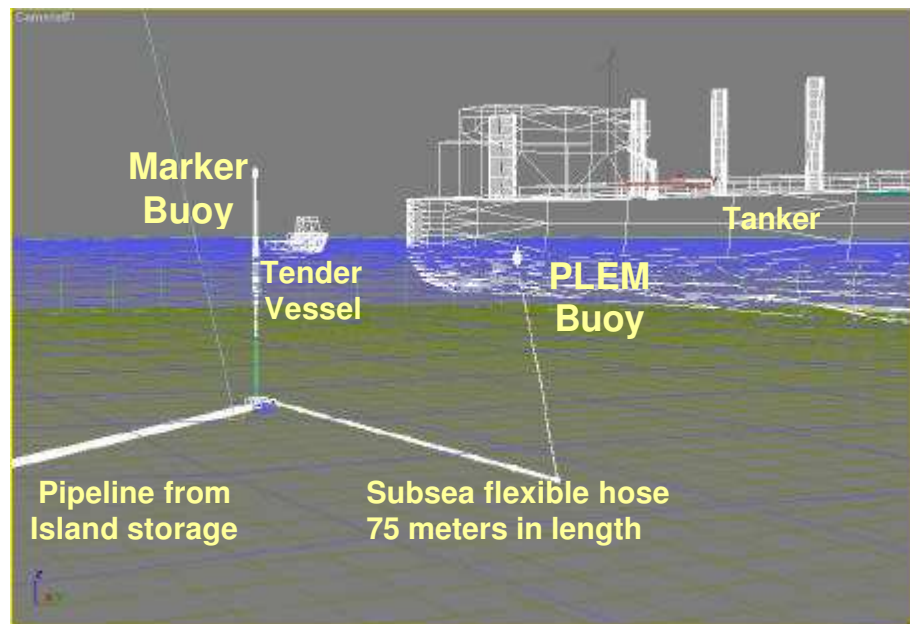

**Figure 9-11: Screen capture (during development)**

It is unknown what really happened, and how the chain wrapped itself around the valve. The weather conditions over the previous weeks saw very rough sea conditions with heavy swells and strong winds and this may have been a determining factor. The hose must be laid straight when it has been disconnected as shown in figure 9-11, if this had not been done properly then this could also have contributed to the accident.

The seabed reconstruction demonstrated how the hose line should be laid out ensuring that the Marker and PLEM Buoys are far apart. One thing that is known is that the chain severed the valve. To demonstrate this, graphics were constructed showing the chain around the valve (Figure 9-12).

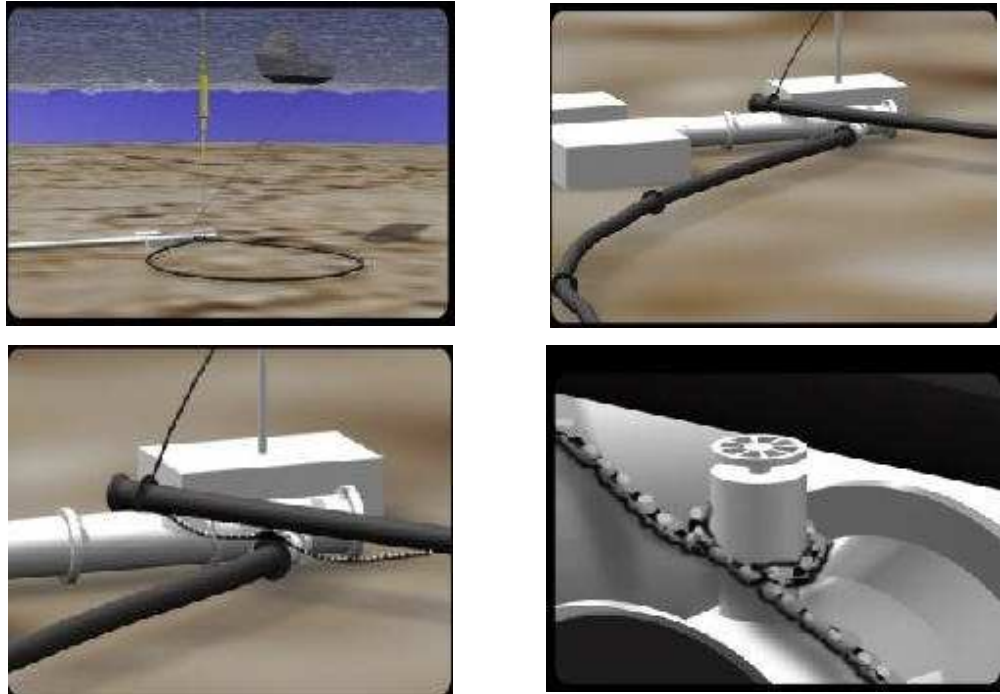

**Figure 9-12: Screen shots of hose & chain entanglement**

The graphics for the surface view was constructed to replicate what the SMEs believed could have happened based on the currently available information. Figures 9-13 and 9-14 demonstrates some of this information with the tender vessel collecting the PLEM Buoy from a close proximity to the Marker Buoy and delivering it to the tanker for the crane to winch the hose aboard.

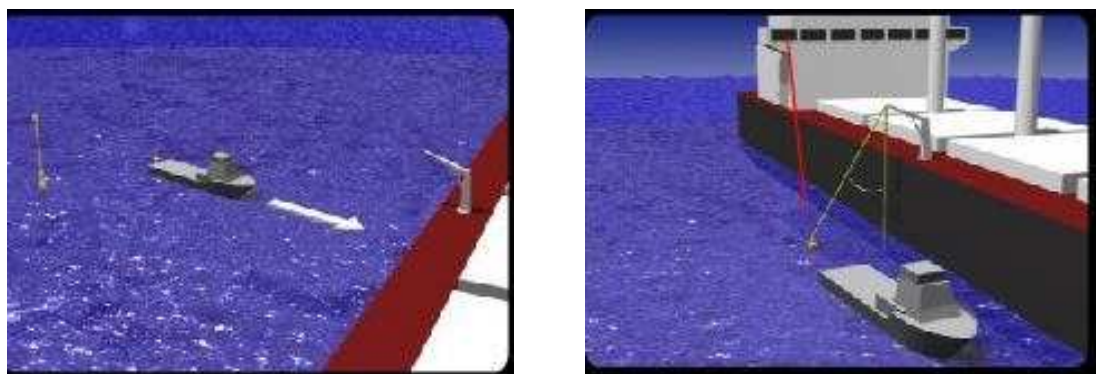

**Figure 9-13: Screen shots - tender boat approaching tanker**



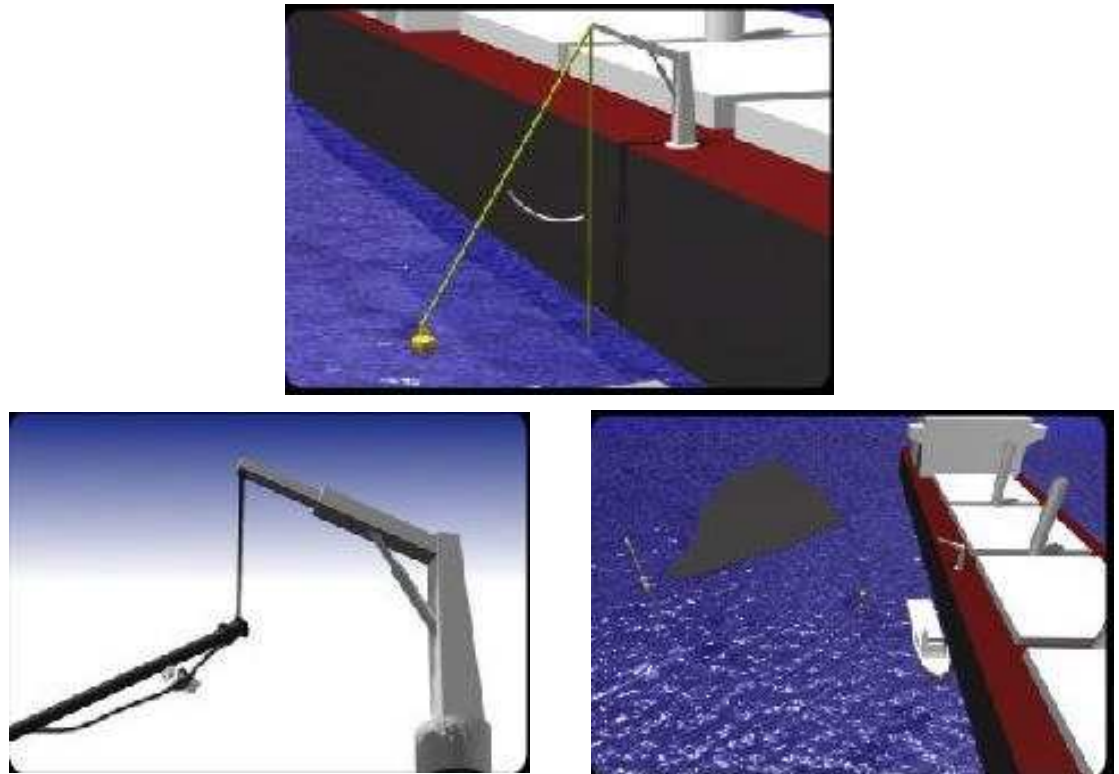
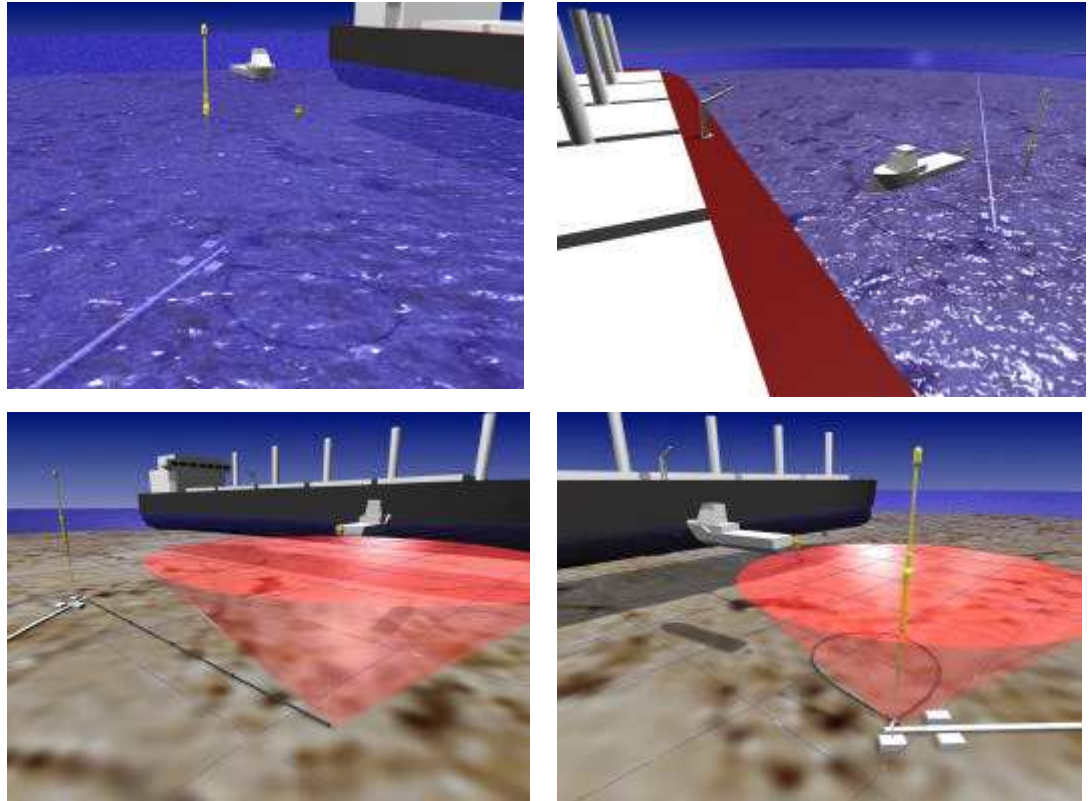

**Figure 9-14: Screen shots - tanker crane lifting hose**

The graphics then present what the safety officer and the people connecting the hose to the winch should have seen, which was the angle of the crane rope coming aboard. The line of the rope should be almost vertical when coming from the seabed and not at an angle as stated by a number of witness testimonies.

The graphics also depicted the final outcome would have been visible to all, that is, the hose breaking the surface of the water along with the hang-off-chain with the valve snared in the chain. The last visual is of the spillage being evident on the surface of the water. There is no evidence that the spillage was noticeable before the hose and valve came to the surface.

With varying testimonies and with no absolute certainty except for the length of the chain between the PLEM Buoy and the end of the subsea hose, a *zone of probability* existed regarding where the PLEM Buoy was in relation to the Marker Buoy. This *zone* was created as a red circle as shown in figure 9-15.



**Figure 9-15: Screen shots of the zone of probability**

This *zone of probability* would provide the investigators with tangible results given that the water depths were not available and that the distance between the PLEM Buoy and the Marker Buoy at pick up time was not known. The workforce knew that the first section of chain was caught around the valve and given that the length of the chain from the PLEM Buoy to the end of the subsea hose was known, then a cone can be traced with the tip (centre point) being positioned over the submerged valve.

#### ?? ***Calculating the zone of probability***

Using conventional mathematics and calculations for a right angle triangle using Pythagorus' Theorem, which is ( $c^2 = a^2 + b^2$ ), the *zone of probability* can be calculated.

From the information provided we know that the PLEM Buoy chain length was 3 x 11metre sections of 22mm links. From navigational charts and local knowledge we were able to obtain an estimated depth of water.

From a further conversation with a local expert, the investigation team estimated that the water depth was around 20 metres. Therefore with a chain length of 33 metres and a water depth of 20 metres, the radius would be:  $c^2 = a^2 + b^2 = [33^2 = 20^2 + b^2] = [33^2 - 20^2 = b^2] = [1089 - 400 = b^2] = [689 = b^2] = [b = 26.25]$ .

Therefore the radius = **26.25metres**

It is interesting to note at this point that the above calculations were derived using both accurate figures and local knowledge. From these values, the radius of the zone of probability (Figure 9-16) was calculated to be 26.25 metres.

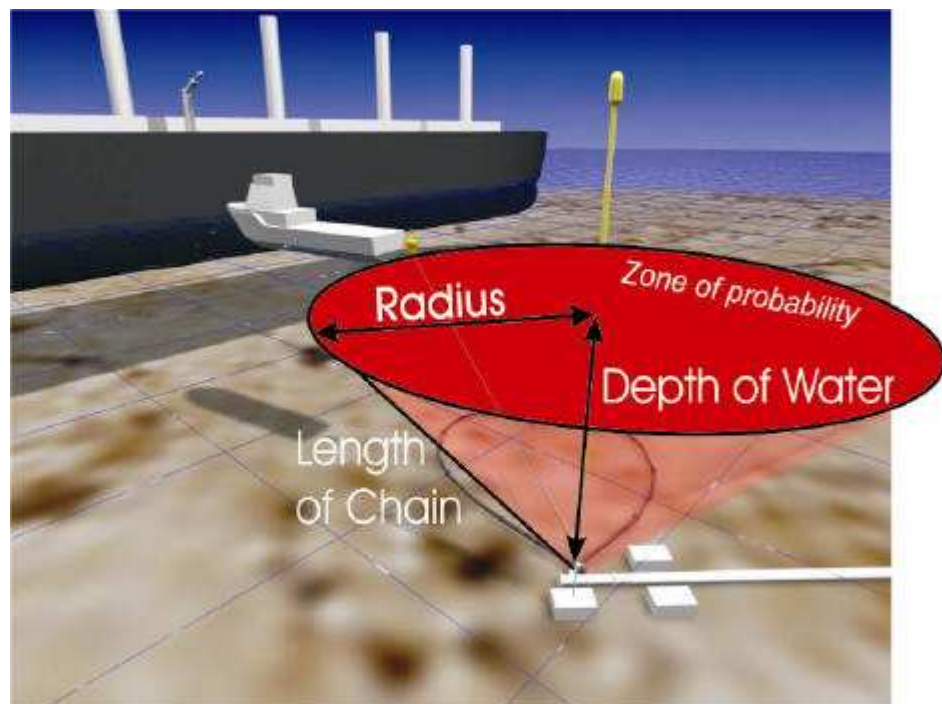

**Figure 9-16: Zone of probability calculated**

This means that the PLEM Buoy is calculated to be no more than 26.25 metres from the Marker Buoy in any direction. An interesting aspect of this is that some of the witness statements indicated that the PLEM Buoy was about 20 to 25 meters away from the Marker Buoy when the PLEM Buoy was collected, while others said that the PLEM Buoy was at least 50 to 60 metres away.

### ?? **Outcome of the reconstruction**

The witness statements were not consistent, with some saying the PLEM Buoy and Marker Buoy were a good distance apart, some provided more acceptable distance figures, while other statements thought they may be close but not that close and some did not notice anything.



The reconstruction had to be based on the most reliable information (which was that the valve was tangled on the hang-off-chain). This information and the known distances allowed the position of the PLEM and Marker Buoy to be defined within a *zone of probability*.

The DoIR investigators and the Crown Solicitors Office representative were very impressed with the CG&V presentation. During this meeting it was agreed that some animations of the witness statements would also be beneficial to present to the Defence. It was also agreed that the current information (graphics and storyboard) would be used at the first meeting between the two legal teams.

The calculation of a more accurate *zone of probability* using measurements that could be better substantiated was also thought to be useful considering the varying reports on distance between the PLEM Buoy and the Marker Buoy.

In the process of developing the animations an e-mail was received advising to stop further work as the Defence had sought further information on what the Prosecutor was submitting (part of the disclosure) and also to stop any further costs being incurred, indicating that a likely guilty plea was evident.

A settlement was achieved and part of the terms of the settlement included non-disclosure of certain information. This limited the amount of detail which could be included in this thesis.

## **Training Application**

A training application based on this reconstruction was not developed due to the sensitivity of the information. However the following describes what the intent of the training application would have been and what format would have been used.

### **?? *The design and setup***

The training application would have been a video based training package. The reason for this is that a video player is always available, but a computer may not be standard, however the creation of a DVD was not out of the question.

A tanker visits many ports and may only visit a particular port once a year. Consequently there could be changes as to the docking procedures and collection of the subsea hose between such visits.

The video could refresh the viewers on the type of port and terminal they are approaching and how best to dock, pick up the supply subsea hose, approach the collection points and any other peculiarities. There could also be an overview of the facilities and an animation of how best to anchor the tanker and how to retrieve the PLEM Buoy and connecting hose. The video, using CG&V, could also point out that if a hose is surfacing at a particular angle then there could be problems. The CG&V would also demonstrate how to put the hose back in to the water for the next tanker.

The proposed video would have been about 5-10 minutes in length.

## **Conclusion**

The Robens (1972) report on 'Safety and Health at Work' in the UK and the Piper Alpha Disaster Inquiry findings in 1988 dramatically changed the way that Safety and Health was seen and the way the petroleum industry accepted and adopted the safety case regime.

The case study used storyboard techniques for the development of the 3D model using 3D Studio Max. 'What-if' scenarios in 'real time' were conducted with instructions from the SMEs. The 3D models were not rendered (left as wireframes) thereby allowing greater interactivity and flexibility.

The ability to overlay additional information in the form of a *zone of probability* from calculations, demonstrated the flexibility of using CG&V.

The DoIR investigators and Crown Solicitors were impressed that the information demonstrated using CG&V would not have been possible to show using other conventional methods as it took place in deep water (over 22 metres) and in an environment that could not be easily contained. The ability of the CG&V to 'take' people to the incident area without actually visiting the scene helps reduce the cost of travel, but ultimately safety, as no one has to go underwater to view the scene.

The fact that the information was not used in a court room but was used in some way by the Prosecution in preparing for the case demonstrates that it has a role to play in providing evidential information.

One of the objectives of using reconstruction is to present the factual information so that all parties agree and that the information cannot be disputed. This then

either shortens the court time or enables a settlement. In this case study the CG&V assisted a rapid settlement to be achieved.

# 10 FEEDBACK AND ASSESSMENT OF CASE STUDIES

## Introduction

This chapter reviews a set of completed evaluation forms which assess the impact of this research as well as briefly looking at some studies that researchers and industry personnel have conducted on various uses of CG&V.

Many studies have shown that students learn best when a variety of teaching methods are used, and that different students respond to different methods. To this end, computers are being increasingly used as teaching tools. These approaches often include multimedia presentations, computerised question-and-answer sessions, and realistic simulations of situations too complex, costly or hazardous to bring into the classroom (Bell and Fogler, 1995).

In any accident investigation inquiry the outcome from the investigation team is often a complex affair. There is frequently a problem in transferring this complex information to both experts and to members of the public. CG&V technology allows information to be presented in trials, industrial hearings, public enquiries and settlement claims evaluations in an accessible and easily understood visual manner. The experience of the US courts has demonstrated the overwhelming advantage of using computer-generated evidence to aid understanding among all people involved in a range of courtroom scenarios. There are three main perceived benefits to using computer-generated displays in the courtroom.

Firstly, they aid in jury and judge understanding the complexity of the issues presented to a jury increases, the amount of interest, comprehension, and retention will decrease (O'Flaherty, 1996). According to the American Bar Association, jurors are 650 percent more likely to retain information when oral arguments are combined with visual presentations during a trial (Marriott, 1996).

The second benefit is that computer-generated displays are a tool of jury persuasion; from a litigator's point of view the persuasive value of these displays is undeniable and an invaluable weapon in their arsenal. Research studies have

found that people are twice as likely to be persuaded if the arguments are supported by visual aids (Lederer and Solomon, n.d.).

The third benefit is that computer-generated displays provides presenters with a better illustration of their arguments. Relevant documents and exhibits are easier to find, evidence can be retrieved instantaneously, and the display can be manipulated for better vantage points (Lopez, 1996).

There is no doubt that computer-generated displays are a powerful tool of persuasion in the armoury of any technologically adept litigator who is prepared to use them. Nevertheless, some have expressed considerable unease about the use of such technology in the courtroom. The consequences of misuse of computer-generated displays cannot be underestimated particularly in the context of a criminal trial. Critics argue that the persuasive power of computer-generated displays is also their greatest disadvantage. Computer-generated displays invariably leave a strong impression on jurors. Indeed, they tend to mesmerise fact seekers and relax their natural critical natures (Jenkins 1976, p 600). The tendency on the part of the jury is to think "*I saw it on TV, therefore it must be true*". Such a conclusion may of course be far from the truth and essentially removes from the jury their fact-finding function: (O'Flaherty, 1996).

*The fear is that the highly communicative nature of computer graphics and the myth of the infallible computer will take the decision out of the jury's hands. The old adage 'seeing is believing' may gain extra force in this setting* (Borelli, 1996).

Another area of concern is the scope for tampering with the evidence in computer-generated displays. This possibility was recognised in the dissenting judgement of Justice Van Graafeiland in the US case of *Perma Research & Development v Singer* (1974)<sup>11</sup>). The learned judge stated that although a computer has tremendous potential for generating more meaningful evidence, "*it presents a real danger of being the vehicle for introducing erroneous, misleading or unreliable evidence.*" While computer-generated displays offer apparent advantages in jury presentation such as varying perspectives, slow-motion and stop-action, such

---

<sup>11</sup> 542 F 2d 111 (2d Cir) cert denied, 429 US 987

facilities can also be used to manipulate the events being shown. (O’Flaherty, 1996). As Marcotte (1989) explains:

*Just as a writer uses punctuation, the selective use of a zoom, close-up and fadeout can accent different points. A constantly moving object can appear to change speed or direction by merely changing the point where it is viewed. While the animation may be technically correct, it can be misleading. The medium shapes the message.*

## 10.1 Previous Work

A number of recent studies evaluating the use of CG&V in computer based training (CBT), virtual environments (VE) and simulation have been completed. The following are some of the conclusions to be drawn from a selection of these studies:

### ?? **Example 1 – effectiveness of low cost VE systems**

A virtual environment training application for landfill site inspection (Figure 10-1) was developed by the AIMS Research Unit using the SAFE-VR software. The application runs on a low cost PC with graphics cards. There are no additional immersive 3D visual aids or haptic devices. The users use a mouse, joystick or similar to manoeuvre around a virtual landfill site spotting and identifying a range of safety hazards within the site.



**Figure 10-1: Screen shoot of landfill application**

Twenty-seven undergraduates in their second or third year majoring in environmental engineering originally took part in a series of evaluation trials of this virtual reality training system. In the first part of the experiment the trainees

watched a video, which was produced by accompanying an expert navigating the virtual landfill site, spotting and identifying hazards. In the second part of experiment each of the subjects used the virtual reality training system and for twenty minutes they tried to spot all the hazards that were present in the virtual landfill site. The results of this experiment showed that the virtual reality training was more effective than the video training. Subjects mentioned that the virtual reality training system had made hazard spotting easy and it had helped them learn and understand issues related to environmental safety in a landfill site (Nasios, 2001).

To further support the value of CG&V as an educational tool, the UK's Environment Agency adopted the application (Appendix 20) and with a further development to suit their requirement, are using it to train their Inspectors. It enables users to navigate around a landfill site and randomly encounter a typical range of scenarios, hazards and events.

The Environment Agency Project Manager, Howard Thorp made the following comments on the application.

*Whilst the simulation does not seek to replace real life experience, it does offer some real benefits. Users can get quick and easy access to training without waiting for training courses, training budgets or experienced trainers to become available.*

*The programme is cost and time effective, and early feedback from users indicates the retention of key information is enhanced because the approach to training is memorable and stimulating. Many staff are amazed by how much they remember when they come for their second training session.*

### **?? Example 2 - effectiveness of training simulations**

Driving simulators (Figure 10-2) are being employed by several police departments in the United States to help them cope with the expanding demand to improve their drivers' safety and proficiency.



**Figure 10-2: I-Sim PatrolSim™ driving simulator**

These simulators are being used in a variety of applications e.g. Basic Driver Decision Making, Tactical Driver Manoeuvring, Hazard and Threat Awareness, Intersection Analysis, Improving Driver Multi-tasking Skills, Patrolling, Pursuit, Practice of Policies and Procedures, and Emergency Code 3 Response. The lessons learned by these police departments, i.e., Raleigh, NC, San Antonio, TX, West Covina, CA and several others, can provide an introductory look at the benefits, challenges, and techniques that work in a simulator-based, tactical training environment (Welles et al, 2000).

The data collected on simulator drivers spans six contiguous months, it involved the training of 875 officers and was compared to the same six month period the year prior, when no simulator training was used. This data reflects accidents that were recorded on official police accident reports from January to June in both years of 1999 and 2000. The first three months of the simulator's use (October to December 1999) was focused on developing instructor familiarity and instructional techniques.

?? Number of reported accidents: No simulator: June 1999 = 90 versus simulator used: June 2000 = 68

?? Intersection accidents: No simulator: June 1999 = 58 versus simulator used – June 2000 = 15

In this six month time frame, the San Antonio Police Department had also used the simulator to train staff on intersection analysis and situational awareness. Their result indicated a remarkable reduction of 74 percent in intersection accidents and an overall reduction of 24 percent in department-wide accidents. In



1999, intersection accidents represented 64 percent of all accidents and usually resulted in those with the most severe consequences (Welles et al, 2000).

### ?? **Example 3 - effectiveness of CBT and simulations**

The technological challenge for Sand (1999) included producing realistic military force employment actions, in an unclassified environment, which replicated the full range of diplomatic, informational, military and economic interactions, producing learning stimuli for students focused at the operational level of war and fully integrating Global Command and Control System (GCCS) functionality.

Many (military) training courses today are solely based on simulation. Operators are asked to, teach the 'how' and the 'why' of the new system and simulation to practice. Therefore both simulation and tutorials are needed for effective instruction. Tutorials without any form of simulation deny the learner the opportunity to practice what they are being taught. Without 'doing', there is no real learning. Simulations without tutorials do not give the learner the background understanding of why or how to properly execute their tasks (Sand et al, 1999).

*What I hear, I forget; what I see, I remember; what I do, I understand. -  
Confucius 451 BC*

Sand's (1999) conclusions revealed the tangible value of interactive decision-making in the curriculum. For mid-grade officers engaged in humanitarian assistance exercises, theater ballistic missile defense operations or a smaller-scale contingency scenarios the capability to observe the effects of their decisions on the progress of operations was invaluable. The use of realistic documents and GCCS tools reinforced the relevance of the instruction and increased retention. All of this directly affects the preparedness of these officer students to execute responsibilities in joint commands worldwide. Providing appropriate stimuli and then permitting the students to learn and retain the salient lessons required by the curriculum is finally possible due to the interactive nature of the learning environment.

### ?? **Example 4 - effectiveness of simulations**

William and Harris (2001) from the Naval Air Warfare Center, Training Systems Division, Air 4.9T in Orlando Florida, USA, inform us in their paper that the impetus to use simulation in some capacity is getting stronger with the passage of

time. The benefits of simulation are well known. The safety benefits of conducting emergency procedures training in the simulators are obvious. Weapons system training in simulators clearly costs less in the wear and tear of equipment and the reduction in the use of expendables.

The use of simulation allows tactics to be developed in secure environments and certainly the environmental impact is reduced if weapons are not deployed and resulting clean up efforts are avoided. Simulation should increase the efficiency and effectiveness, as well as reduce the risks, associated with training on the operational equipment.

Furthermore, the trends in simulation equipment lend themselves to providing lower cost solutions to the training challenges. The cost of computer hardware is becoming lower, and increasingly more capable so that ever more sophisticated simulations can be created for less funding. It is fair to say that simulations could be applied to solving some of the training challenges if the user community had confidence that the simulations do what they are supposed to do, i.e. provide the training the users need to do their job.

As final examples of Measures of Effectiveness (MOE)s that can be measured and used to determine the effectiveness of training systems or elements of training systems, consider the following data taken from the results of studies conducted at the Surface Warfare Officer School (William and Harris, 2001);

?? These MOEs have to do with human performance attributes that were measured.

?? The Situation Assessment improved because the use of external sources of information increased by 41 percent,

?? Improper phraseology was reduced by 44 percent indicating improvement in communications.

?? Team initiative and leadership improvement was indicated because:

?? The trainees provided 62 percent more situation report updates

?? There was a 46 percent improvement in the clarity and appropriateness of the priorities that were stated.

?? Evaluation of the training effectiveness in team leader training showed improvement in supporting behaviour that was indicated by the trainees passing 66 percent more of relevant information, without having to be asked.

?? Trainees passed 43 percent more performance feedback to their teams.

?? In addition, the training improvement was noted when the teams.

?? Identified 59 percent more of the critical deviations and potential problems.

?? Correctly evaluated 34 percent more of the critical tracks.

### ?? ***Analysis of examples***

The examples presented have been low cost PC based VE through to high-end simulation that incorporates additional training components in the form of CBT.

In all of the examples the users have benefited in learning and understanding and being able to utilise this training in their working environments. Also worth noting is that a system does not have to be expensive to achieve an outcome, as long as the information presented is understandable to the audience it is designed for. In the case of the landfill application it was to spot the hazard by 'walking' around the site. The driving simulator required the user to sit behind the wheel and drive around a VE and the military simulator and CBT application tested a number of activities that the officers could encounter in performing a certain duty. All examples presented the students with interactivity and CG&V applications that they could interact with.

It should be noted that the author did not exclude negative comments on CG&V applications. These are very limited but should be mentioned, for example, the conclusions reached by Thomas et al (2001) from their training experiments was as follows:

?? On the evidence of this experiment, immersive VR technology is not yet sufficiently mature to be considered as a viable replacement for conventional CBT. Better or equal training effectiveness was not achieved with VR.

?? Current immersive VR systems may represent a barrier to effective training due to discomfort and difficulties related to the style of interaction. Remedying these shortcomings should be one priority for further research.

?? Subjective reaction to the immersive VR equipment - despite its problems - indicated a surprisingly favourable impression (although this could be due to a novelty factor that might wear off).

?? Despite the problems revealed in this experiment, advantages over CBT in spatial learning were indicated for immersive VR training, although this did not lead to improved transfer of training as this factor was outweighed by others.

Although Thomas highlighted a number of problems, he did not totally discount the use of VR as a training application.

In conclusion, the use of CG&V applications as an effective training, educational and information tool has been presented generally accepted, even with some limited negative comments.

The following further evaluates the use of CG&V as an appropriate tool to present information using the cases studies that the author has presented in chapters 6 - 9 of this thesis.

## **10.2 Method of Evaluation**

In order to assess the relevance and acceptability of CG&V as a reconstruction and training tool within the minerals and energy sectors a presentation was given to an audience. The audience was of random people who responded to an open invitation to the general public. During this seminar two of the case studies (i.e. case study 1 and 2) were presented. At the end of the presentation a questionnaire was handed to the attendees to complete.

### **?? *The questionnaire***

A questionnaire (Appendix 21) was developed to collect information from people who made themselves available to participate in the seminar, it was to be completed directly after the presentation in a quick and efficient manner where the participants indicated their 'opinion' by placing a tick in the appropriate box. The questionnaire was designed to gather data on participants:

?? Demographics.

?? Recognition and comprehension of the visual material.

?? General views of the visual material.

?? Perception of the visual material.

?? Attitude towards the use of the visuals material.

?? Understanding presented visual material.

The participants were asked to complete the questionnaire after the seminar. They had to tick a rating that they thought appropriate to the question being asked. The rating were as follows:

**0**–Strongly Disagree, **1**-Totally Disagree, **2**–Disagree, **3**–Agree, **4**-Totally Agree and **5**–Strongly Agree.

### ?? ***The presentation***

The presentation was conducted at Central TAFE’s Computer Graphics and Visualisation Centre Perth WA. Figure 10-3 shows the author explaining to the audience how the 3D models are developed. The presentation then demonstrated case studies 1 and 2 and also presented modified versions of case studies 3 and 4 (following the restrictions specified by the lawyers).



**Figure 10-3: Presentation taking place**

The participants attended the presentation on 7<sup>th</sup> May 2002 as part of the Federal Government’s Innovative program for informing Australians of programs in the various scientific and innovative areas that are being pursued in Australia. The event was the Australian Innovation Festival (Appendix 22). The presentation was listed as ‘Forensic Reconstruction using Computer Graphics’ and was a open

invitation to the general public. The presentation lasted ninety minutes and thirty-five questionnaires were returned as a result of this presentation

### ?? **Design type**

The collection of data for analysis can often be categorised in two ways:

?? Experimental – carried out in a controlled or manipulated environment

?? Non-Experimental – carried out in a ‘natural’ environment.

The Non-Experimental method has been used because the natural setting has the advantage of being a real-life situation where information was judged as if it was being used as a training application or presented as information of an event.

## 10.3 Results

### ?? **Demographics of attendees**

#### Employment Areas

As shown in figure 10-4, the ‘government’ sector had the largest representation at the seminar, followed by the ‘private’ sector and ‘students’ with ‘others’ being in the minority.

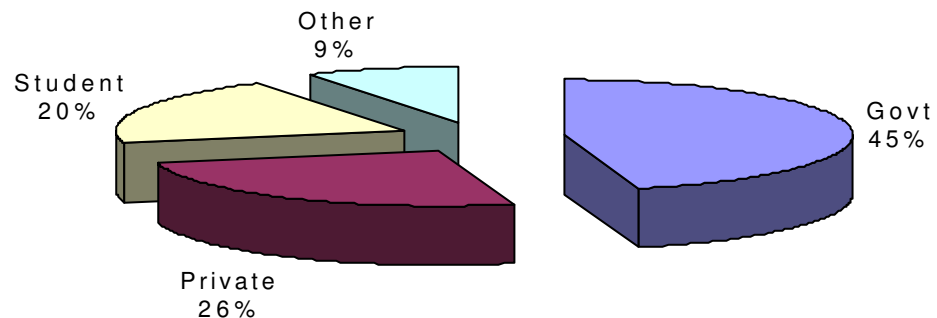

Figure 10-4: Employment area

This presentation was open to the general public and the only two categories that did not register an entry on the questionnaire was the ‘domestic’ and ‘unemployed’ category.

#### Current working environment

The employment background (Figure 10-5) of those attending was considered to be important in assessing the relevance of their responses to the questionnaire.

Although the people employed in 'education' were in the majority, the remainder were evenly spread. The 'legal' and 'medical' sectors were not represented, however a number reported they were 'retired'. They were included on the graph but they could have been part of 'others' group which would have made the 'others' total to 17 percent, thereby creating an even spread.

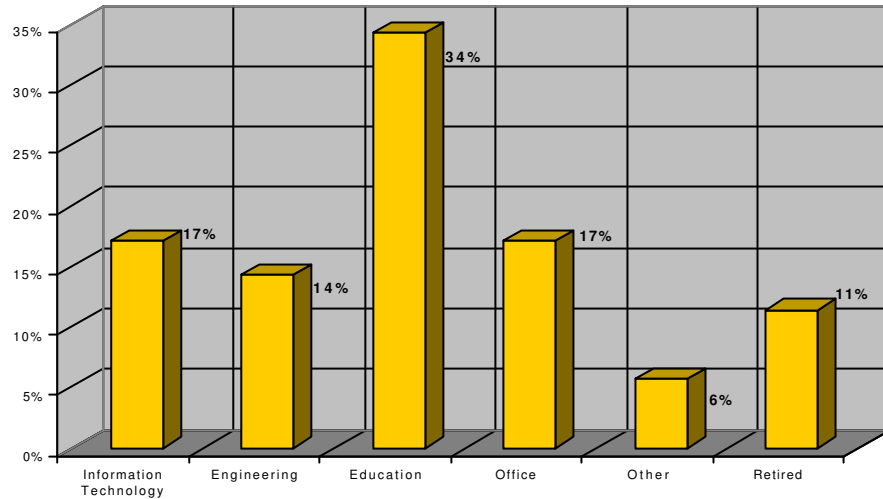

**Figure 10-5: Working environment**

Education

Figure 10-6 demonstrates the qualification of the participants and shows that 81 percent of the people had achieved High School certification or higher. Non educated persons were not included in this survey.

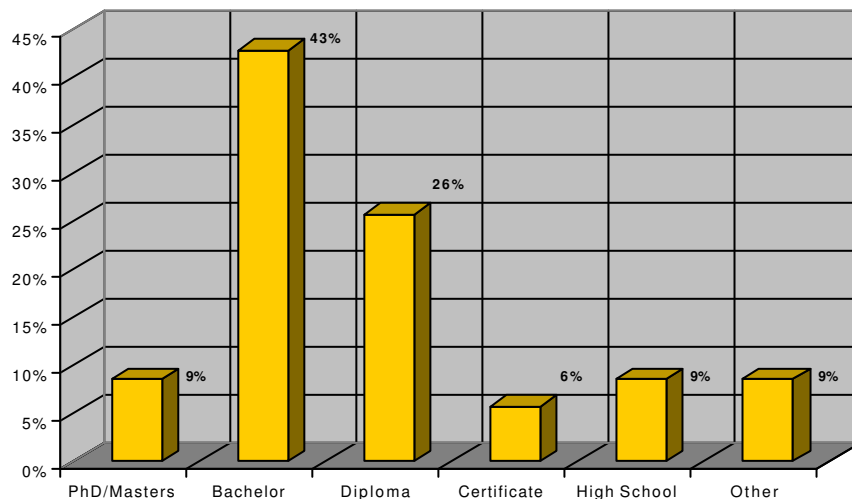

**Figure 10-6: Qualifications achieved by attendees**

Access to Personal Computer

The percentage of participants that have their own personal computer was very high (Figure 10-7) registering 71 percent. It was interesting to note that all participants had access to a computer.

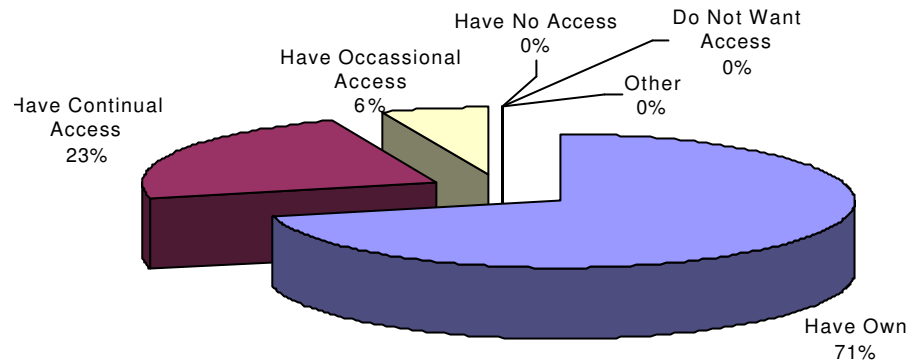
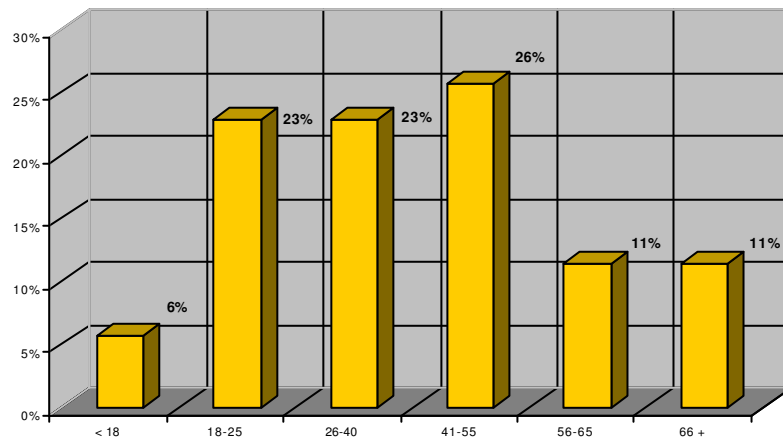

**Figure 10-7: Computer access**

All the participants were therefore computer literate and using PC's regularly or had an interest in using PC's. This knowledge will have some influence as to how the participants assess the presentation.

#### Age of participants

Figure 10-8 demonstrates the good spread of participants ages.



**Figure 10-8: Age**

The fact that the participants came to the seminar via an advertisement and were not selected by the author ensured that the people who completed the questionnaire were representative of a random sample.



**?? Recognition and comprehension of visual material - Q1-3**

Questions 1-3 wanted to establish if the CG&V presented information that was coherent, understandable and recognisable. All responses rated well as demonstrated in figures 10-9,10-10 and 10-11 where most were in the 4-5 category of 'Totally Agree' and 'Strongly Agree'. All the respondents agreed that the graphics did depict what was being described in the talk.

**Q1 – Did the graphics depict what was being described?**

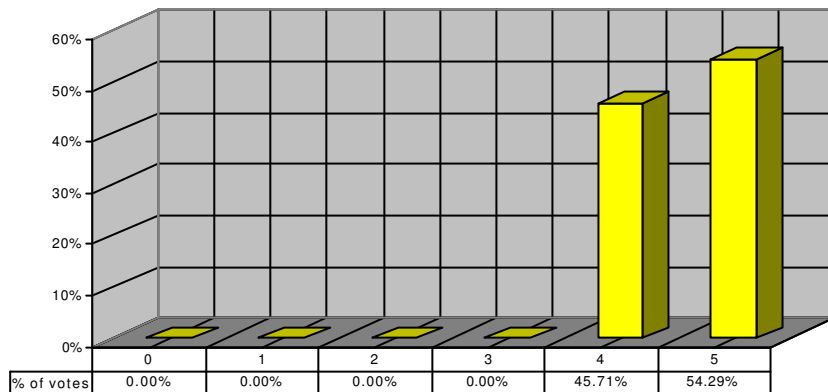

**Figure 10-9: Question 1 – what was being described**

**Q2 – Did the graphics demonstrate additional information that was not spoken off?**

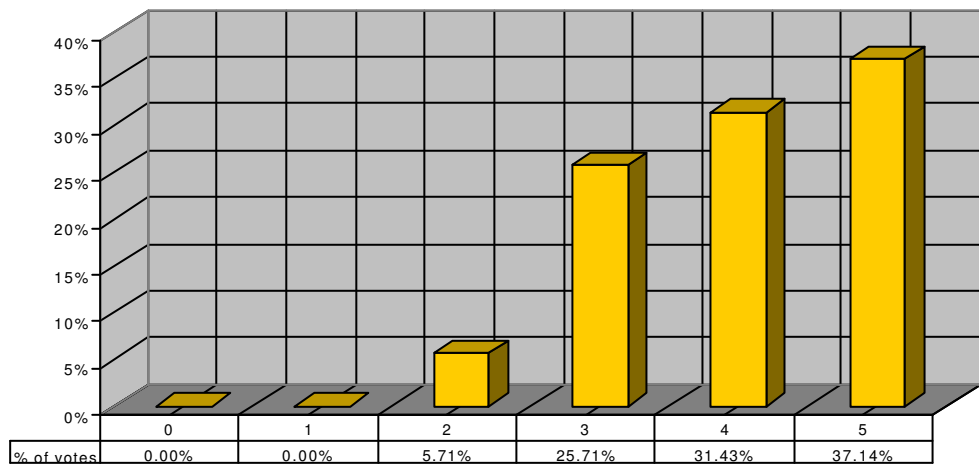

**Figure 10-10: Question 2 – additional information**

**Q3 – Did the graphics give you a preconceived idea of what was going on ?**

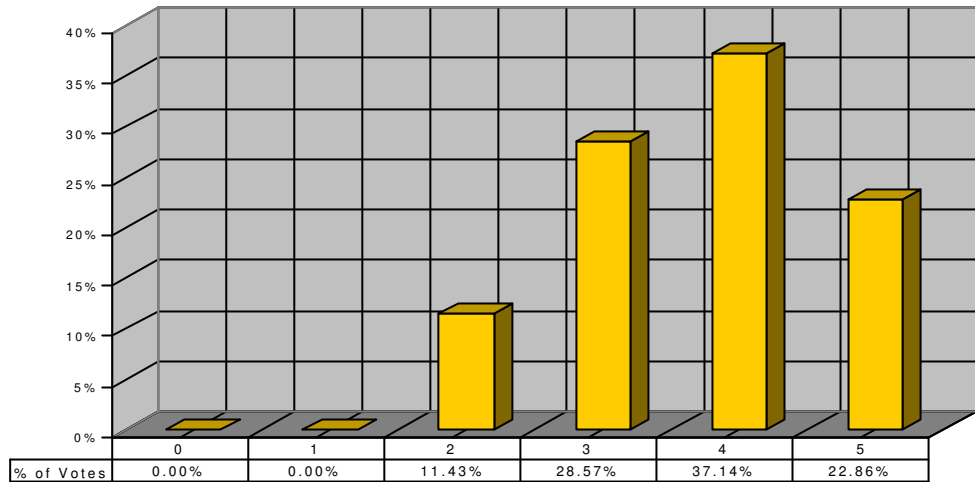
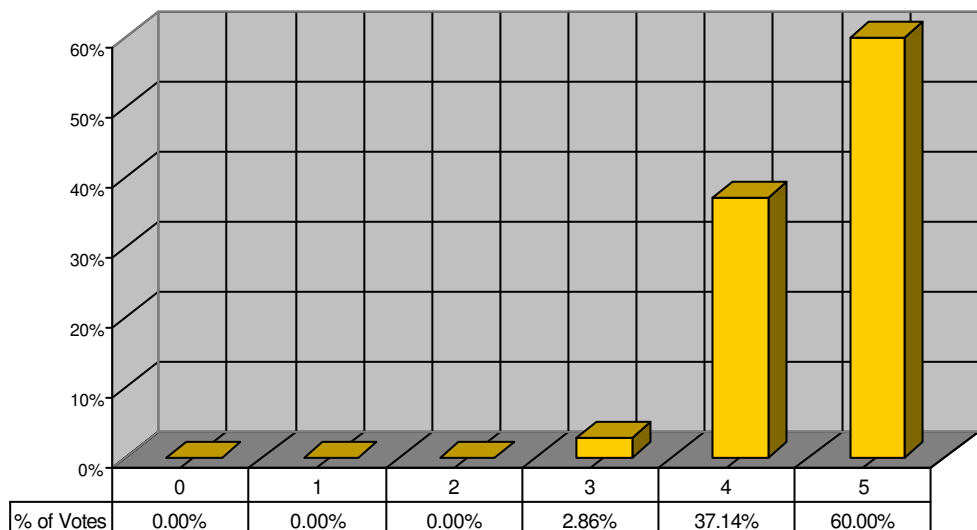

**Figure 10-11: Question 3 - perceived ideas**

?? **General views of visual material - Q4-5**

This section, (questions 4 and 5) focussed on the amount of understanding conveyed by the material being presented. The results (Figure 10-12 and 10-13) with a majority in the 4-5 category of 'Totally Agree' and 'Strongly Agree', indicates that the CG&V helped the group achieve a better understanding and provided assistance where technical issues were raised.

Question 4 – Did the graphics provide information for a better understanding ?



**Figure 10-12: Question 4 - better understanding**

Q5 – Would graphics help you understand technical discussion?

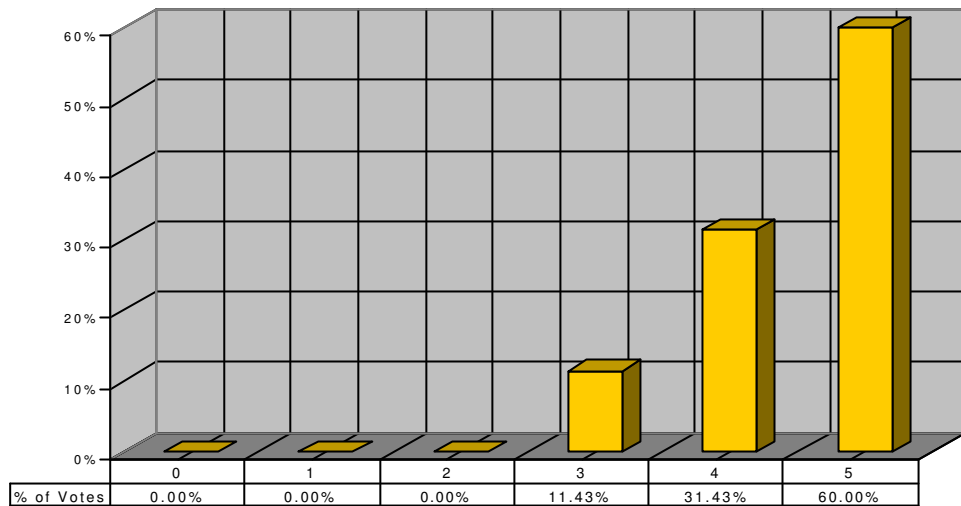

Figure 10-13: Question 5 – understanding technical discussions

?? **Perception of the visual material - Q6-7**

For questions 6 and 7, the group were required to indicate the level of realism portrayed in the presentation and the quality of the animations.

Figure 10-14 shows the results for question 6 the group recorded a majority rating of 3-4 category of ‘Agree’ and ‘Totally Agree’ which infers the CG&V demonstrated medium to high levels of realism.

Q6 – Did the graphics depict reality?

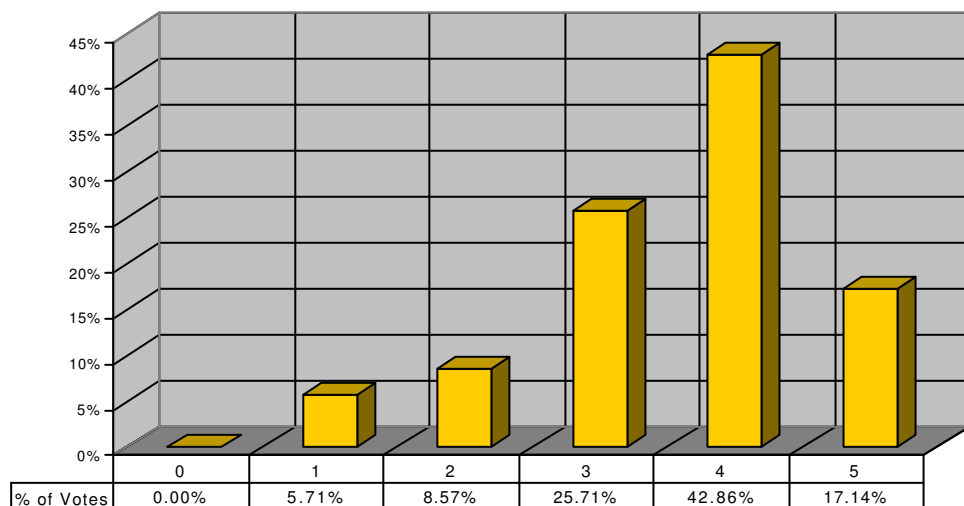
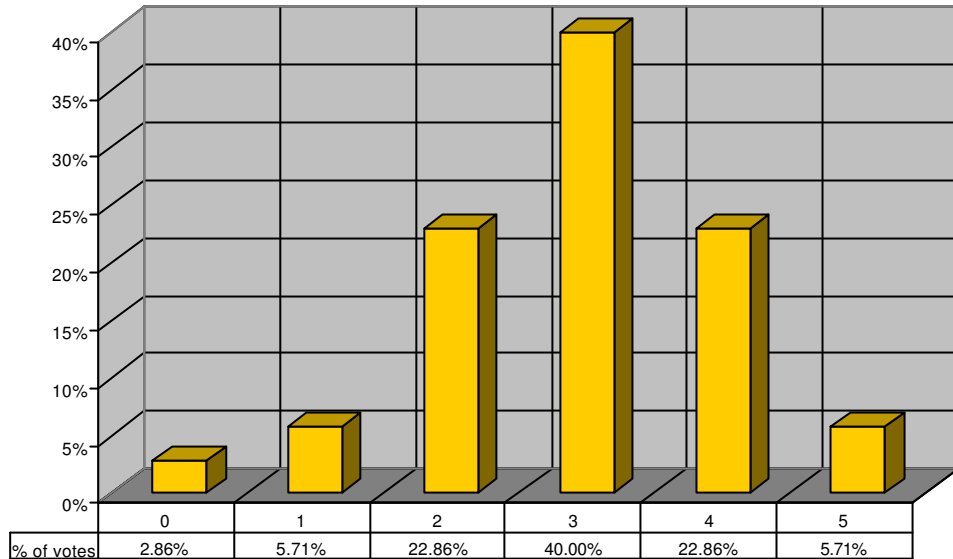

Figure 10-14: Question 6 – depict reality

Figure 10-15 shows the results for question 7 and the group recorded in every rate from ‘No sense’ of reality to ‘Yes it did provide a sense’ of reality. However 84 percent of the group recorded values of 2, 3 and 4, with 40 percent recording a

value of 3, indicating that they ‘Agree’ and the graphics demonstrated medium levels of realism

Q7 – Did the graphics provide a sense of reality?

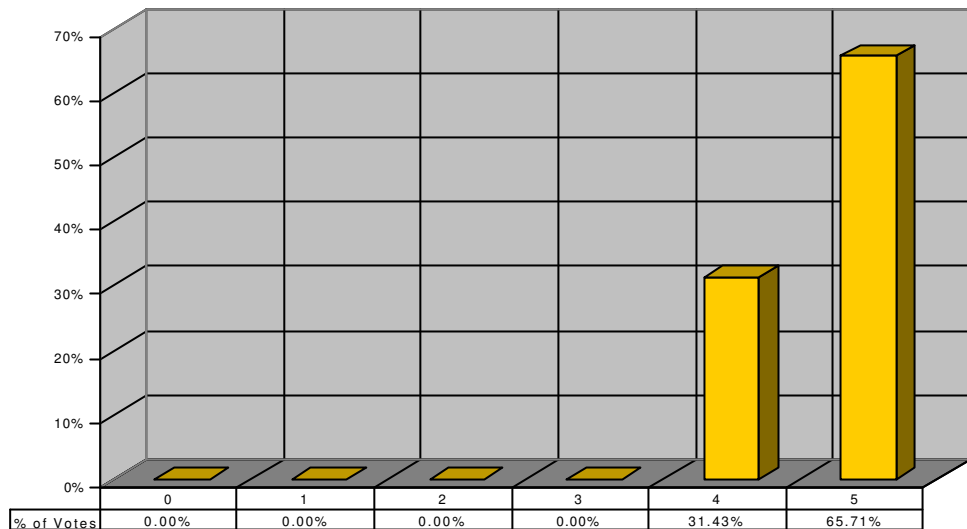

**Figure 10-15: Question 7 – a sense of reality**

**?? Attitude towards the use of the visuals material - Q8-9**

Questions 8 and 9 required the group to record their attitude to the usefulness of CG in the presentation. The results (Figure 10-16 and 10-17) obtained from the group recorded a majority in the 4-5 category of ‘Totally Agree’ and ‘Strongly Agree’, indicating that the participants were very supportive and positive about the use of CG&V as a means of assisting in providing explanations and as a tool for demonstrating ideas in a visual manner.

Q8 – Are graphics a useful tool for explaining things



**Figure 10-16: Question 8 – tool for explaining things**

Q9 – Is graphics a useful tool for demonstrating things?

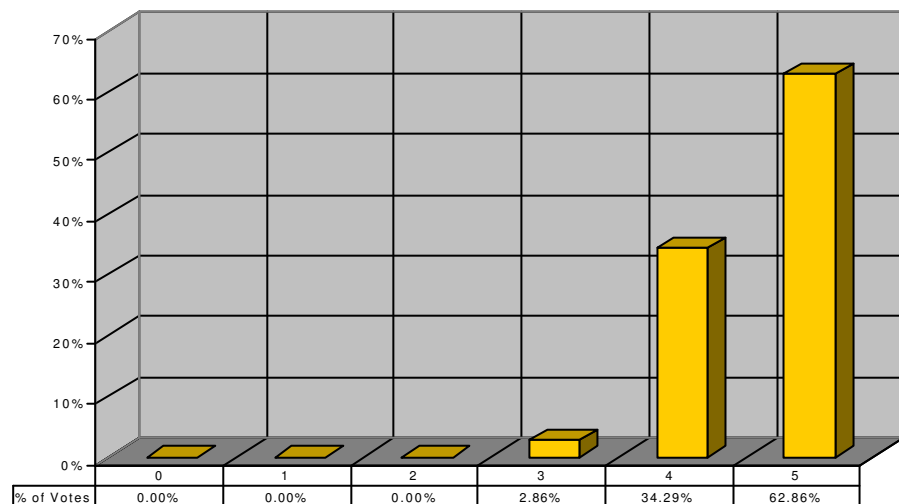
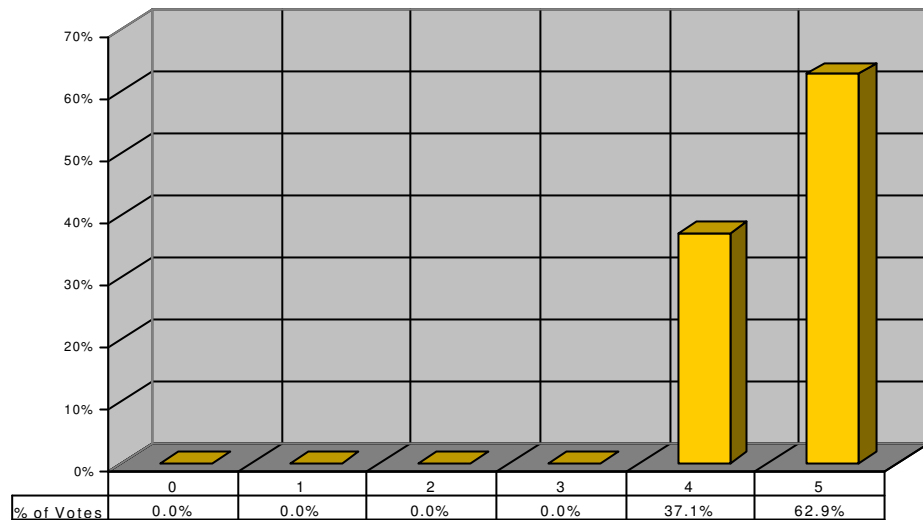

**Figure 10-17: Question 9 – tool for demonstrating things**

**?? Understanding presented visual material - Q10-11**

Questions 10 and 11 invited participants to indicate their understanding of what was presented. Figures 10-18 and 10-19 both received high rating of 4 and 5 indicating that the CG&V presentation did what it was intended to do, and that it helps with the understanding and provides additional information. These results suggest that the CG&V presentation proved to be most useful. The responses to Question 11 also imply an improved understanding of what was presented which would be important in both courtroom and training environments.

Q10 – Did you understand what the graphics were showing?



**Figure 10-18: Question 10 – understand what was showing**

Q11 – Did the graphics provide information that you did not know before?

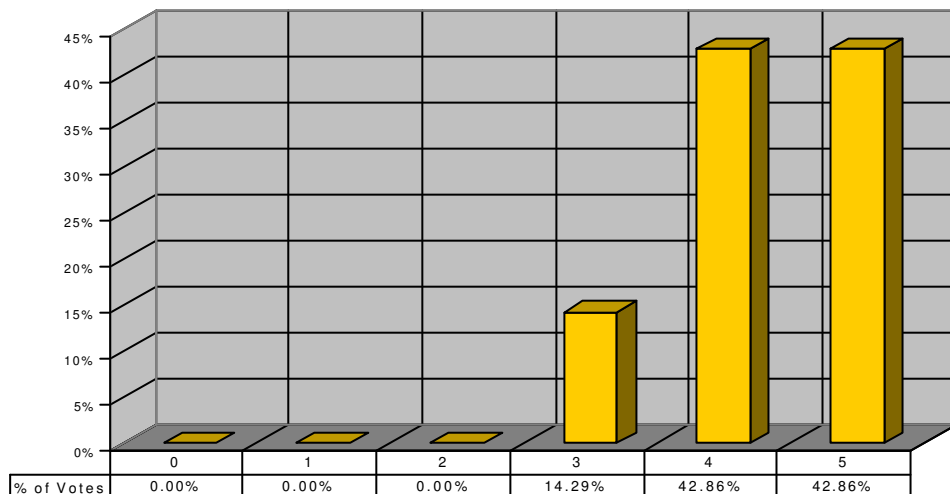

**Figure 10-19: Question 11 – provide additional information**

The following table (Figure 10-20) represents the response to all eleven questions and the average scores that they achieved.

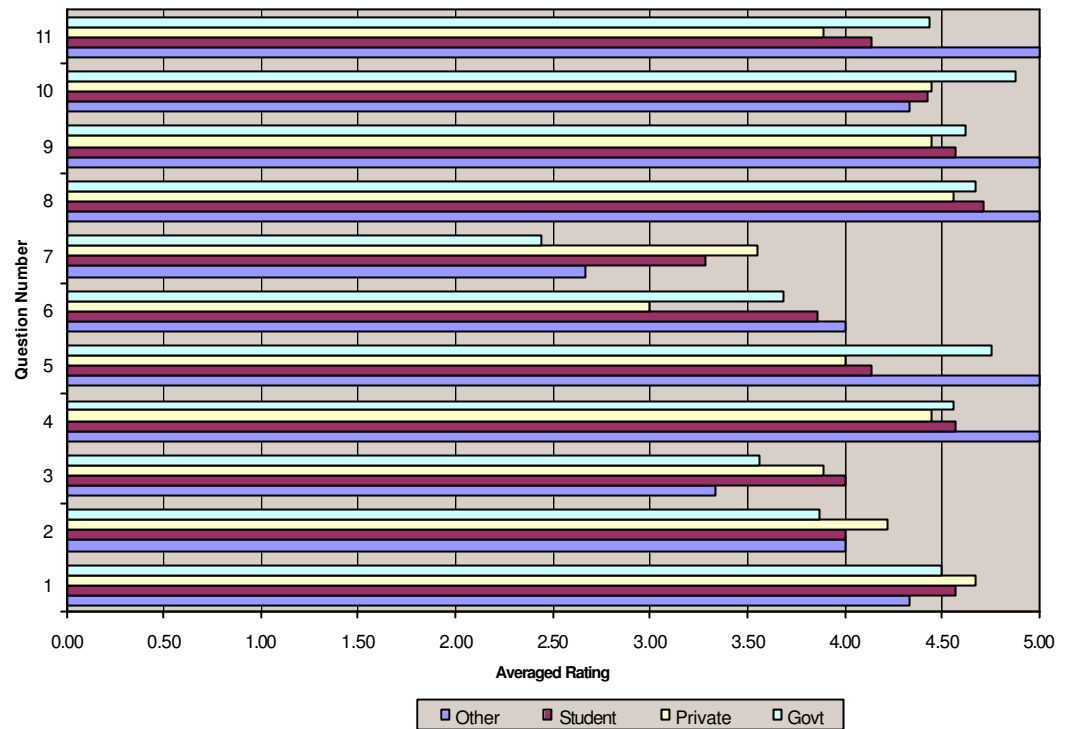

**Figure 10-20: Results of all 11 questions (Averaged out)**

## 10.4 Conclusion

On the basis of these results it appears that the general public will accept the use of CG&V technology as a means of reconstructing accidents and incidents and presenting general information and complex issues.

The number of institutions and companies conducting research into the effects and usage of CG&V as a training tool and the number of companies using CBT and VR for training purposes also clearly demonstrates the acceptance and utility of these technologies.

The simplicity of this project's evaluation exercise was justified, since it involved a reasonable cross-section of populace and the assessment of four CG&V presentations.

The research questions addressed in this thesis are:

?? What are the merits and level of acceptance associated with the use of computer visualisation techniques for the reconstruction of incidents/accidents?

?? What are the merits and level of acceptance associated with the use of

computer visualisation techniques for training applications developed from the reconstruction of incidents/accidents?

The small test sample results obtained from the 35 returned questionnaires and the additional presentations contained in this thesis (1999-2003), the responses have clearly demonstrated the merit and level of acceptance in using CG&V technology for information dissemination and training purposes.

There has been little if any negative comments on the use of this technology. The only negative comments received related to the cost of developing training applications and producing a reconstruction and a comment said partly in jest that:

*If I am going to present evidence using graphics in court to explain things – then what will I talk about ? (Heenan, 2001).*

The evaluation has confirmed the indication that CG&V used in accident reconstructions and leading to training applications has relevance and potential in the field of mine accident and incident reconstructions as well as assisting in training. None of the subjects used in the sample evaluation had negative comments, the comments received throughout the research have always been positive.



# 11 CONCLUSIONS AND RECOMMENDATIONS

## Introduction

The purpose of this work was to identify and investigate the potential of using computer graphics and visualisation as a tool for developing reconstructions of accidents and incidents within the Western Australian minerals and energy sector. This work was extended to include turning the developed reconstructions into training tools. In this chapter a brief overview of the work is given followed by the presentation of conclusions and recommendations.

### 11.1 Overview of Thesis

Ever since man has been able to communicate using words and drawings, there has been a rapid advancement in society. The transfer of information and the formatting of that information so that it could be understood by peer reviewers, has been a challenge. The greatest challenge of all has been that of taking complex information and making it understandable to all who are interested.

From the use of drawings of mine disasters as shown in the Penny Magazine in the early 1800's to current complex 3D graphics of geological structures, visuals have helped provide minerals and energy information for people. The use of computers has provided the means of taking complex (and not so complex) information further by providing new mechanisms for viewing information. New software and procedures for providing ways to present the information are constantly under development.

This study set out to assess the use of CG&V to recreate, using animations, 2D and 3D models and other digital images, accidents and incidents that occur within the Western Australian minerals and energy sector.

Four case studies were developed. Two hypothetical cases were based on past accidents and incidents and two cases on current accidents using information that investigators and SMEs had collected for use in legal proceedings.

The hypothetical cases used were not problematic since all the information was previously available and if information was missing a SME provided the information on request.

The real case studies provided challenges since information was not available, often because it was not thought to be of any use. Also it was impossible to present some of the information to the public to obtain their assessment and feedback, as it was sub-judice and restricted to the legal teams and courts. The real case studies were also influenced by external parties (for example other legal teams, judges and the investigative team) who were predominantly unfamiliar with this technology

Each hypothetical case study produced a reconstruction and a training application within the project timescale. The real cases, only one provided a reconstruction and some training material, but it took longer due to delays in court appearance and the many changes required in the reconstruction. Delays were also caused by the additional requirements asked for when the team saw the many 'final' draft presentations. The other real case study only produced a reconstruction in draft format due to the case being settled out of court. This was seen as a success as this is one of the benefits of CG&V, to assist in the understanding of issues that may save court time.

The evaluation of the case study reconstructions comprised a single presentation to a group of people who responded to an advertisement. The seminar was based on the use of CG&V as a reconstruction and training tool. The evaluation of the information received from the presentation produced encouraging feedback indicating the suitability and acceptance of the computer graphics technology and concepts in producing accident reconstructions and training applications in the minerals and energy sector.

## **Summary of Finding**

This section presents the conclusions drawn from the research undertaken.

### **?? *Current CG&V technology***

This research has provided many examples of the use of CG&V as used by the minerals and energy sectors. It has demonstrated that the industry is not against

the use of this technology as long as the industry sees a benefit to its use. Currently most of the CG&V applications such as Ventilation Planning, Mine Planning and Truck Driving Simulators assist the industry in minimising costs of production, these are seen as direct (tangible) benefits. Where as reconstructions and most training applications are seen as intangible that is, they may make a difference, industry seems reluctant to invest.

### ?? ***Hypothetical case studies***

The use of hypothetical case studies proved to be extremely useful. The cases were delivered into complete packages, whereby the information to be translated was clearly defined as well as the desired outcome.

In case study one (the underground fire) some information had already been presented to the mining industry (not using CG&V) to demonstrate the problems that currently exist in the industry that can easily result in fatalities.

Case study two (the truck rollover), had been used by the Department of Minerals and Petroleum Resources (as a text based training course) to train their new inspectors in the procedures of recording and investigating accidents.

The hypothetical cases were easier to develop due to the flexibility available in the development of the models and environment. Although there was an effort to provide accurate reconstructions, the users requirement was a reconstruction useful to the industry. From these reconstructions, the development of a training application was seen to be more beneficial than the reconstructions. This was probably due to the fact that the reconstructions were not being used in a legal context, only to provide graphics for the training applications.

The hypothetical reconstructions are accurate and based on the information provided. The main aim of these from the DoIR's perspective was to provide information so that people could understand what was happening, which is more of a training outcome, than providing accurate and factual information that may be challenged in a legal sense.

### ?? ***Real case studies***

The use of actual incidents which were in the process of being investigated, and required for courtroom presentation, provided an insight into the expectations of

the end-users. One of the additional concerns that these studies brought with them was the information required to ensure that the reconstructions and training applications were accurate and that what was being presented to the SMEs, legal teams and potentially the courtrooms could be backed up by either witness statements, specifications or other items that could substantiate the graphical evidence presented.

In case study three (the exploration drilling) the information had been available for a number of years as the case was due for appeal. The main issue was how to reconstruct the incident ensuring that the three Supreme Court Appeal judges understood all the technical information referred to by the SME who was to present this information in the trial. One other issue that affected the case study was the many changes that occurred because the witness and legal team kept making changes as to how they were going to present their testimony.

In case study four (the offshore spillage) the incident happened underwater in a remote location. The information available was either a few days old (photographs) or only available from witness statements, plans and diagrams. The actual scene could not be preserved and the investigation team only took information that they thought was of value since the use of CG&V was initially not an option. One other issue was that the SMEs had an idea of what may have happened and this was analysed using the accurate 3D model that was developed. Therefore they were able to visualise a number of 'what if' scenarios and start to develop the sequence of events which probably lead to the accident.

In both of these case studies, time was a factor. In case study three the Supreme Court set a date and the team had to prepare and be ready. The prosecution team was able to move the date three times and these delays added a further 18 months to the time the Appeal was finally conducted. This presented the SMEs with additional time to review and revise their information. The outcome of the trial was that the Appeal was successful on all three counts. The decision of the court has yet to be released as it contains sensitive information that may be used in further legal action, so it is not known how effective the judges thought the graphics were in providing information.

In case study four, again the date was set for a court appearance and the CG&V had to be available for disclosure to the opposition. As the CG&V was being

developed the prosecution team was meeting with the 'offenders' and before the CG&V was completed, the two parties had agreed to an outcome – they settled out of court. The CG&V although used by the prosecution was not 'officially' presented to the defense team in the act of disclosure.

For both of these studies the training applications although seen as useful were not deemed (from a legal perspective) to be as important as the accuracy of the reconstruction for court usage.

### ?? ***Developing the reconstructions***

During the course of the research work, the PC platform technology increased the storage, processing and rendering power. Also during the work, two major software upgrades for 3D Studio Max were released. The research started with 3D Studio Max version 3, this then went to version 4 which had many problems, then 3D Studio Max version 5 was released to correct the problems. Rhinoceros was also launched the year the research started, it also released a Rhino version 2 in 2001 during the research project. Although these technology and software changes provided some challenges it also brought about the ability to develop faster and present images, animations and scenarios in a more flexible and realistic manner.

### ?? ***Developing the training applications***

The only case studies that reached this phase were the hypotheticals due to there being no legal restrictions imposed on the data used. The hypothetical case studies were presented as training applications using PowerPoint and HTML as the mechanisms for accessing the training packages.

At the start of this research it was mentioned that the industry that was being addressed was mainly located in remote areas and access to computer technology was limited. The training media that the applications could run on had to be low cost and available to public. The research achieved this by producing the applications of a generic nature that could be placed on media such as CD, Video or broad cast over the internet, all of which are available to the public and run on low cost equipment.

## ?? **Evaluation and assessment**

The evaluation and assessment produced encouraging feedback regarding the suitability and effectiveness of CG&V technology and concepts. The evaluation has confirmed that CG&V has an increasingly important place in assisting with accident investigations and these can be further developed into training applications.

The participants that provided the evaluation and assessments of the case studies presented were seen as a true cross section of the general public and potential jury members. Therefore the results presented can be viewed as support and acceptance that the use of CG&V is acceptable to the general public and supports the research questions.

Throughout the research work demonstrations have been conducted showing the case studies in there various forms of development to a wide variety of people and industry groups. During the presentations there has been little if any negative comments on the use of this technology. The only negative of comments received related to the cost of developing training applications and producing a reconstruction. The final versions of the case studies that were presented to the evaluation group did not receive any negative comments or questions of costs, the evaluation group just recorded very positive acceptance of the use of CG&V as indicated in their score sheets.

The evaluation confirmed earlier indications that CG&V used in accident reconstructions and training applications has relevance and great potential in reconstructing and investigating mine accidents and in the training of personnel.

## **Recommendations**

The following are the recommendations which arise from this research work:

?? CG&V should be introduced more widely to the accident investigation teams in the minerals and energy sector to assist with their investigations. For example, virtual environments could be used to provide ‘what-if’ scenarios of current accident scenes and demonstrate how potential incidents could occur and be avoided.

?? The development of CG&V based on accident information for educational

purposes should be encouraged. CG&V learning systems can assist students to think critically, develop an understanding of the subject and help them in developing their capabilities, skills and competencies.

?? CG&V should be used more widely in courtrooms and as a tool to assist lawyers and subject matters experts to present their statements (which are often technical in nature) in a meaning full way to an audience including judges, lawyers and jury who more often than not have very limited knowledge of the scientific and technical issues involved in industrial accidents.

?? CG&V should be introduced to the minerals and energy sectors as part of their tool box presentations, thereby presenting information that is not ambiguous and is consistent across the industry.

?? There is need for more formal and rigorous evaluation of the type of CG&V used on a particular accident and the choice of training methods used to convey the information to provide a more conclusive assessment on the usability of the CG&V for accident reconstructions and training applications.

## **11.2 Further Work**

The author had difficulty in locating research papers that present actual measurements of the performance of CG&V as a means of training personnel. Thurman (1999) also indicated that he attempted a literature search to locate studies where simulator-based training was the topic of discussion. He focused his search on the four domains where public perception has it that simulators are used extensively in training (nuclear power, medicine, commercial aviation, and NASA). His search lead to 103 published articles documenting the benefits of simulator-based training. Yet, a closer examination revealed that the majority were meant to be descriptions of a new or improved simulators. Of the 103 articles, only four actually supplied any assessment data (and they were limited to simple reactions and opinions of trainees and/or trainers).

This research project was intended as a preliminary investigation and assessment of the potential use of CG&V within the minerals and energy sector of Western Australia in the area of accident and incident reconstruction and training

applications. The results to date clearly indicate that this technology has great potential, however further investigation is required in the following areas:

?? The type of training application that would suit a working mine.

Each mine is different and the use of CG&V ranges from PC virtual environments such as Safe-VR, CBT on CD-ROM and the conventional Video. A study of the most appropriate CG&V for use in various situations is essential to find out the following:

?? Will the workers prefer to study at home using the training application

?? The type of interaction the worker will best learn from, whether it be a Safe-VR walk around spotting hazards or a CD-ROM that presents information then requires the user to answer questions before moving onto the next area.

?? The type of CG&V that would suit an industry operating in remote sites

?? The type of CG&V application that users want. Taking into consideration that a new 'generation' of workers are joining the workforce who have grown up with new technology being used as tools for training.

?? Memory retention of mine workers operating in a fly-in/fly-out arrangement.

Due to the remoteness of many minesites a large proportion of the workers are transported to the location for set periods then transported back 'home' for time off. This is commonly called fly-in/fly-out where you stay at the minesite for 2-3 weeks at a time doing 12 hour shifts for the whole period. The worker is then returned 'home' (fly-out) for his recreation time for maybe one week before returning to the minesite. Some of the questions to be addressed are:

?? Will the workers prefer to study at home using the training application

?? Will the worker be better instructed before or after his 12 hour shift.

?? The most appropriate CG&V application for minesites e.g. 'tool box' instruction at the minesite or full seminar away from minesite.

The above work if undertaken needs to address the issues raised by Thurman (1999) in that results should be measurements and performance of the application and the user and not designed for marketing and sales.



### **11.3 Concluding Remarks**

This research project set out to investigate the use of computer graphics and visualisation as a reconstruct and training tool and, in particular, to examine its potential in the Western Australian minerals and energy sectors. The study looked at two hypothetical case studies based on actual events and two real cases, one that went to court and the other which was settled out of court.

The study focused on the development and reconstruction of the accidents and incidents to ensure the people viewing the accident/incident would get a greater understanding of the events leading up and to the accident/incident. The information was then progressed towards developing a training application with the view to improving safety standards and reducing accidents and incidents.

It is clear from the literature review, the research conducted and the evaluation performed, that the use of computer graphics and visualisation as a reconstruction and training tool is well-established and offers the Western Australian minerals and energy sector the means by which its employees can enhance their ability to understand the causes of accidents and incidents thereby improving the safety training of personnel.

The research questions raised in this thesis have led to the conclusion that:

?? That there is merit and a high level of acceptance associated with the use of computer visualisation techniques for the reconstruction of incidents/accidents as well as training applications developed from the reconstruction of incidents/accidents?

## **APPENDICES**

## APPENDIX No.1

### Appendix No. 1:- New Hartley Disaster 16<sup>th</sup> January 1862

At 10:30am on the 16<sup>th</sup> January 1862 the back shift at the New Hartley Colliery were in the process of relieving the shift which had started at 2.30am. As was the practice at that time one shift relieved the preceding one at the coalface. The first set of eight miners had started to ascend to the surface but of these men only three were to eventually see the light of day. As the cage was rising between the High Main and the Yard seams it suddenly came to a violent halt. Without any warning the beam of the giant pumping engine at the pit top suddenly fractured and twenty-one tons of cast iron hurtled down the shaft taking with it shaft supports, pipes and ventilation partition. The debris crashed on top of the cage severing two of its four support chains and flinging a number of miners to their deaths while the remainder miraculously clung to the damaged cage. A blockage 30 yards deep then formed at a vital part of the shaft allowing no means of escape for the trapped miners below.

Initially Mr John Short, the colliery Enginewright raised the alarm on the pit top. He then went on to take charge of the initial rescue attempts.

By the end of the first day the damaged cage had been removed and planking placed across the shaft to enable rescuers to be lowered and raised. By Friday the enormity of the disaster was realised, and it was decided to seek the services of locally renowned mining engineer William Coulson who readily volunteered

On Saturday work was progressing steadily but was hampered by falling water and insecure shaft supports. Their efforts were concentrated on reaching a now buried emergency trap door which had been used for pump maintenance and which provided a direct link to the Yard seam in which the miners were trapped. By the Monday of the rescue attempt Coulson's men had cleared the trap door but unfortunately they were driven back by the escape of a large volume of gas. The rescue attempt had to be abandoned until an adequate supply of fresh air could be brought to the point of rescue. This took a further two days.

By about midday on Wednesday a small entrance was forced through the trap door, but again Coulson's men were forced back by gas. Eventually this cleared and the rescuers moved cautiously into the maintenance tunnel below the trapdoor where they found pools which suggested that the trapped men had tried to break out from below the blockage.

On the following Saturday the recovery of the bodies began. Due to the restrictions still present in the shaft it took seventeen hours to bring them all to the surface. (Gardiner, 1983).

**See next page for explanation of accident**

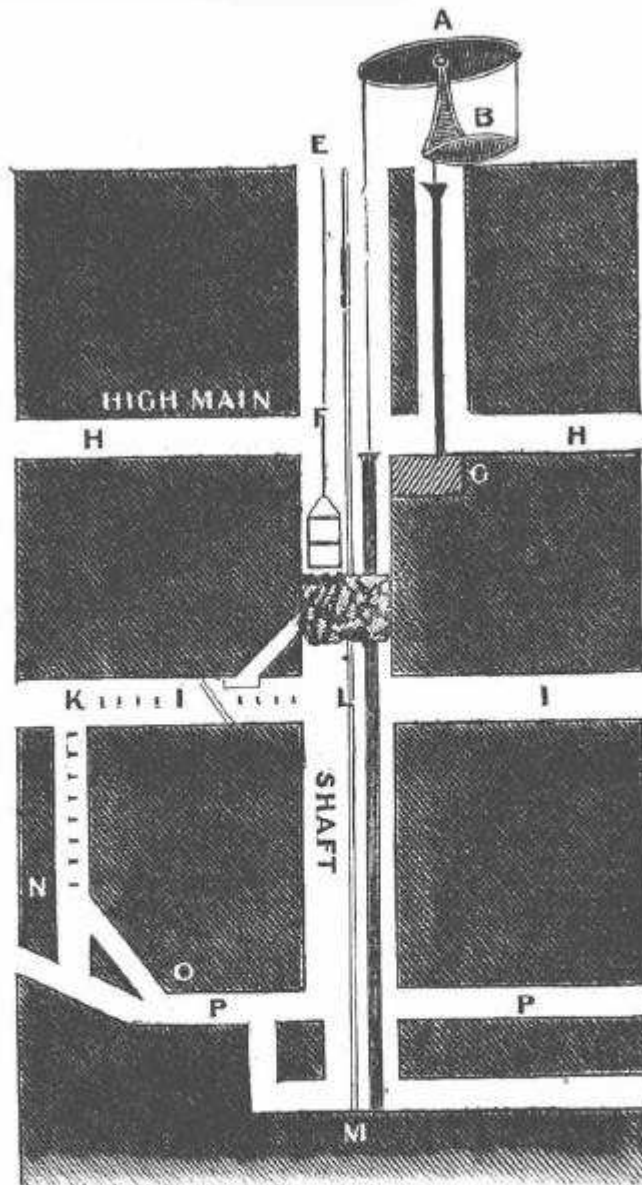

- A. Point where large beam broke, 16ft. 6in. from the spears.
- B. Lower beam for top set of pumps in small shaft to 7 fathoms below High Main Seam, making the high set of pumps up to surface 45 fathoms.
- E. Top of pit, or Main Shaft, 12ft. diameter, and 105 fathoms to the bottom of the sump (M), where the third set of pumps rest.
- E to F. 38 fathoms to High Main Seam.
- F to L and M, as shown by blank line, are two sets of pumps, of about 30 fathoms each.
- G. Bottom of staple for high set of pumps, showing the sump, 7 fathoms below High Main.
- H H. High Main Coal Seam, not working.
- I I. Yard Coal Seam, not working,
- K. Top of staple, up which the men ascended by a wire rope ladder from the top of the slope drift, 10 fathoms.
- N to O. Slope drift.
- P. P. Low Main, where the principal workings were in progress.

SECTION OF THE WORKINGS.

Fatal accident at New Hartley Colliery – 2/1/1862 (Winstanley 2001)

## **Appendix No. 2:- The Maypole Colliery Disaster 1908**

Just after five in the evening on Tuesday, 18th August 1908, a deep rumble was heard within a radius of about a mile of the Maypole Colliery in Abram near Wigan. The thing dreaded by miners and their families had happened.....an explosion somewhere deep underground in the tunnels and roads of the pit.

A thick column of soot and smoke rose out of the No 1 shaft towering several hundred feet above the colliery yard. Within minutes wives, mothers and children rushed to the pit yard. Park Lane itself, now a neat, modern housing estate, was a quite narrow road at the time.

On a normal working day the miners would hide their tobacco tins and matches in the thick clumps of grass beneath the wooden fencing, knowing that it would still be there, untouched, when their shift ended. Even in relatively gas-free mines, which the Maypole was not, no flames were allowed and these rules were strictly adhered to.

One of the first people on the scene was the manager of the Maypole, Arthur Rushton, who was just returning from a holiday. His eye witness account was published at the coroner's inquest.

*"I had been away on holiday for twelve or thirteen days, and I was driving home when, nearing the colliery, I heard a low rumbling noise and saw a cloud of dust. I got out of my cab and went straight to the colliery.*

*When walking between the lamp room and the fan-house, I saw that some of the masonry of the fan-house had been blown away. It was only then that I realised what had occurred. I walked to the general office and wrote a telegram to Mr Hall, His Majesty's Inspector of Mines, and afterwards I went to the pit. The headgear for No 1 pit was partially demolished and the rope was hanging in the headgear. The cage itself had gone below. "*

*"Knowing that after-damp was coming out of the pit, I went to No2 with Mr Picton, the under manager of No 1 pit, and instructed him to get a rescue party together, go to the Wigan Junction Pit, descend the shaft and get into the seven feet mine that way. I then got the engineman to knock down the No 2 pit and, in about five minutes, they got a signal from the seven feet. I took it, therefore that there was nothing wrong in the seven feet.*

*I then told Mr Nelson who had been in my place while I was away, and the Under Manager, to get the cage from the Seven feet, and if all was right in the Seven feet, they must lengthen the rope and go down into the Wigan mine.*

*I then went to the Wigan Junction and found the rescue party had already entered the mine. A little way in, they came across a fall which blocked the whole road. I ordered the roadway to be cleared, and in the meantime I returned to the Maypole, where I found Mr Hall in my office. We went down the No 2 at about 9 o'clock and joined up with Mr Picton and his party who had made their way from the Junction."*

The Maypole's two shafts offered access to a labyrinth of roads and tunnels travelling several thousand feet below ground and linking with several other adjacent collieries, Wigan Junction and Bickershaw at several different levels.

A little over an hour before the explosion, at 4pm, the Maypole's day shift had returned to the surface, leaving the maintenance men, the firemen, the men who manned the pumps and the shot firers who would bring down the next day's coal in the miles of tunnels.

There were 78 men left underground, three working in the Seven Feet mine and seventy-five in the Wigan Four Feet. All the workers in the Wigan Four Feet lost their lives.

The pithead was crowded with families within a few minutes of the explosion. Many of those who waited for news of their husbands, sons and fathers kept a silent vigil at the pit head for several days until the full extent of the loss was known.

At about 9 o'clock in the evening Rushton and the mines inspector Henry Hall went back down the No 2 shaft with a rescue party from Garswood and started once more to work their way along the tunnels. Just before midnight they found the first body, charred and horribly mutilated and arranged for it to be brought to the surface. Hours later a second badly burned body was found, and then, as the night progressed five more. Some were found with hands covering their faces in a futile attempt to protect themselves from the advancing fireball. One man in his fifties was found on his knees in prayer, the last few seconds of his life spent preparing himself for the inevitable.

The inquiry was opened on August 20th 1908 in the Congregational Mission Church at Abram. The coroner, Sam Brighthouse, (third from right on front row) had already taken the jury to view the bodies of the seven recovered victims at the Abram Smallpox Hospital, and when the representatives of the interested parties took their seats it was clear that the mineowners would be strenuously denying any suggestions of negligence in the operation of the mine. The manager and under-manager would be stressing that they were in no way at fault and the Miner's Federation would be pressing the interests of the dead men, their families and the pitmen everywhere in the country.

The initial stages of the inquiry were taken up with identification of the recovered bodies and with determining the safety level of the gas in the Maypole. In a tense and electric atmosphere Rushton denied that there were dangerous pockets of gas. When questioned about shot firing he stressed that only those explosives designated as safe by the Home Office had been used and that the firemen's reports had shown no dangerous collections of gas.

The Miner's Federation were concerned to show that the Maypole had been inadequately ventilated, that shot firing had taken place at improper times, and when gas was present, and that there had been a general lack of proper supervision by the management. Their witnesses gave evidence that it was sometimes so hot that men had to be fanned while working. Rushton strenuously denied this.

As far as the shot firing was concerned the Federation witnesses were adamant that shot holes were sometimes drilled when there was gas present, and one witness actually stated that he had been present on one occasion when the fireman William Henry Monks, had fired a shot, not only when there was gas present but when the day shift men were still down the mine.

Tom Ellis, on behalf of the mine owners strenuously fought to refute this evidence, but damaging evidence came out during the examination of the night under-manager Isaac James.

The coroner opened out the questioning when a legal argument developed whether firemen's reports, or duplicates, were necessary under the legislation. Brighthouse grew impatient and cut through the argument, addressing James.

*"When we know how dangerous gas is in a mine, and how important it is that it should be dispersed, it is curious isn't it, that two firemen should report gas on the Saturday morning and you should take no notice of it in your report?"*

The night under-manager replied that it was his report....that is a report of what he did himself. This evasion pushed him deeper into a hole of his own making.

Counsel for the Federation stepped in, - *"Your explanation is that it was an oversight?"*

*"Yes." - "In each of the five cases?"* coroner Brighthouse asked in wonderment. - *"Yes."*

Flustered and trapped the unfortunate under-manager cried out, "I have done no deed wilfully."

The admission nevertheless had been made. The reports filed above the mine were not original or accurate: they stated there was no gas present in the mine when the firemen had reported there was.

As the inquiry dragged on through April, May and June of 1909 the parade of conflicting evidence seemed endless.

Tom Ellis acting for the mine owners found himself facing adversaries not prepared to give an inch. One such was Isaiah Houghton, a dogged independent man who had worked in the mines for 46 years. He insisted that a fireman had been shot firing in the Maypole while the day shift was down, and he would not be shaken in his story.

*"He was working in the daytime, at the time I am telling you. You needn't try to change me I am too old a dog to be changed."*

Though Ellis pressed the old man hard he would not be moved. - *"I am telling the truth. I have not come here to tell a lie. I have been very near pumped for to do."*

And as the laughter spread around the courtroom he added, - *"I have been tidy persuaded on it."*

Although the management were found to be largely at fault for the unfortunate accident no prosecutions arose from the inquiry.

**(See sketch of disaster on the next page)**

THE BURNING MAYPOLE COLLIERY AT WIGAN: THE ACCIDENT EXPLAINED.

DRAWN BY E. B. HURDMAN, MAP SPECIAL ARTIST AT WIGAN.

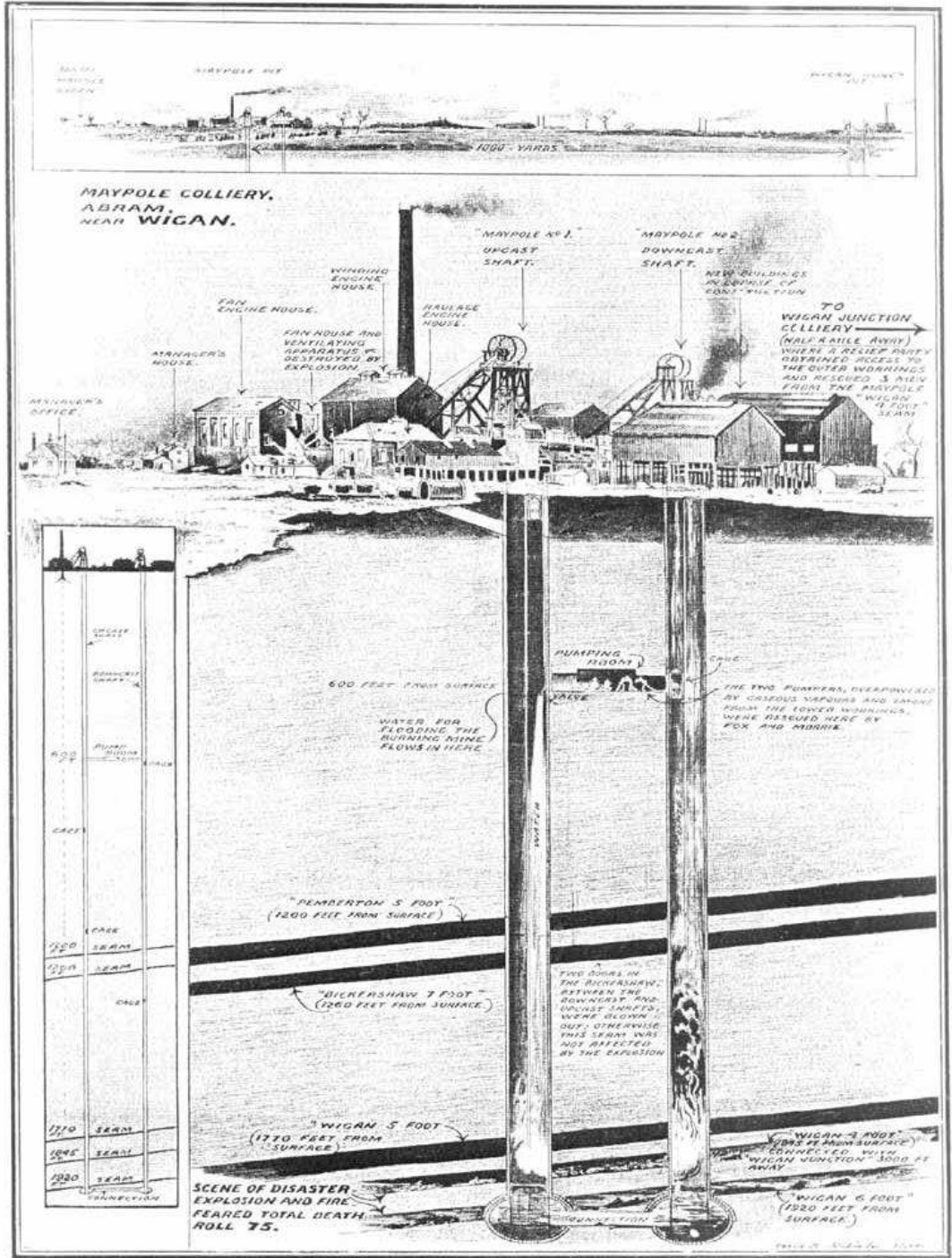

SECTION OF THE MAYPOLE MINE SHOWING THE BURNING SEAMS

(11) In plan of the shaft at a single instantaneous drawing of the Maypole Colliery showing the two shafts, the head-gear, and water. It shows the position towards the eastward of the shaft and shows the method of flooding the mine to get out the fire. When the explosion occurred the upper shaft would have the level of 6000 feet and the lower shaft would be at 1770 feet. The diagram gives the run of the mine and the relative distance of the Wigan Junction shaft which the latter would have been 1770 feet up.

The Burning Maypole Colliery at Wigan - 29/8/1908



**Appendix No. 3:- Longford Royal Commission – Letter to establish.**

**ELIZABETH THE SECOND BY THE GRACE OF GOD  
QUEEN OF AUSTRALIA AND HER OTHER REALMS AND TERRITORIES  
QUEEN, HEAD OF THE COMMONWEALTH**

To The Honourable Sir Daryl Michael Dawson, AC, KBE, CB.  
Brian John Brooks BE, FIEAust, FAIP, FAIE, FIE

GREETINGS:

WHEREAS:

- A. Gas extracted by Esso Australia Resources Ltd (“Esso”) and BHP Petroleum (Bass Strait) Pty Ltd (“BHP”) is processed at gas production and processing facilities at Longford, Victoria (“the Longford facilities”) operated by Esso.
- B. On Friday 25 September 1998 an explosion and fire occurred at the Longford facilities.
- C. As a result of that explosion and fire two persons were killed, a number of persons were injured and all gas supply from the Longford facilities ceased.
- D. It appeared to the Governor in Council that the available supply of gas was or was likely to become less than was sufficient for the reasonable requirements of the community and accordingly the Governor in Council, acting under s.62F of the *Gas Industry Act* 1994 (“the Act”) by proclamation declared that Part 6A of the Act was to apply.
- E. Following that proclamation, directions were given under Part 6A of the Act to effect the cessation of all but essential gas usage in those parts of Victoria which rely upon the supply of gas from the Longford facilities.
- F. The Governor of the State of Victoria, in the Commonwealth of Australia by and with the advice of the Executive Council has deemed it to be expedient that a Commission should issue to you in the terms set out below.

NOW THEREFORE the Governor of the State of Victoria, in the Commonwealth of Australia, by and with the advice of the Executive Council and acting pursuant to section 88B of the *Constitution Act* 1975, appoints and constitutes you

The Honourable Sir Daryl Michael Dawson AC, KBE, CB  
Brian John Brooks BE, FIEAust, FIAP FAIE, FIE

to be Our Commissioners

AND HEREBY APPOINTS The Honourable Sir Daryl Michael Dawson, AC, KBE, CB to be Chairman of the Royal Commission.

### Appendix No. 4:- Timeline of Australian Mineral and Energy

#### Discoveries.

- 1848 -Discovery of lead in the bed of the Murchison River, WA.
- 1851 - Discovery of gold at Clunes, Castlemaine and Ballarat, Victorian gold rushes started.
- 1852 - Payable gold discovered at the Nook, near Fingal, and at Nine Mile Springs (Tasmania). Gold also discovered at Gulgong (NSW).
- 1853 - Riots on Ballarat goldfields (Vic). Storming of the Eureka Stockade on 3<sup>rd</sup> December.
- 1857 - Brown coal discovered at Lal Lal (Vic).
- 1858 - Gold discovered at Canoona (Qld).
- 1859 - Copper recognised in the Cobar area (NSW).
- 1860 - Copper discoveries at Wallaroo and Moonta (SA).
- 1862 - Copper-rich lode found at Clermont (Qld).
- 1864 - Coal discovered in Greta/Cessnock/Maitland field (NSW); principal Australian source of gas coal. Blair Athol coal field (Qld) found; seam is 90ft thick.
- 1869 - Record gold nugget "Welcome Stranger" (2284oz) found near Dunolly (Vic).
- 1870 - Gold discovered at Birdwood (SA).
- 1871 - Discovery of tin at Mt Bischoff (Tas) and Inverell (NSW).
- 1872 - Payable gold discovered in Pine Creek area (NT).
- 1874 - Brown coal deposits found in the Latrobe Valley (Vic).
- 1882 - Lead, zinc, copper orebody at Captain's Flat (NSW) first worked. Gold nugget found between Roebourne and Cossack (WA).
- 1883 - Lead, silver, zinc discovered at Broken Hill (NSW). Collie coalfield found in WA (commercial mining began in 1898).
- 1885 - Opening of Broken Hill Proprietary silver mines. Gold found at Hall's Creek in the Kimberley district of WA. Silver/lead discovered at Mt Zeehan (Tas).
- 1888 - Tin found at Greenbushes (WA). Black coal found at Leigh Creek (SA).
- 1889 - First mining of brown coal in Victoria.
- 1892 - Gold discovered at Coolgardie (WA), also in areas now known as the Dundas and Mt Margaret goldfields. First bore sunk in Coorong area (SA) in search for oil.
- 1893 - Gold discovered at Kalgoorlie.
- 1893-94 - Copper, lead and zinc discovered at Roseberry (Tas).

1900 - Iron ore from Middleback Ranges (SA) mined by BHP to provide flux for lead smelting at Port Pirie. Natural gas encountered in water bore at Roma (Qld).

1904 - Scheelite deposit found on King Island (Tas).

1906 - Natural gas reticulated in Roma (Qld). Uranium discovered at Radium Hill (SA).

1915 - Opening of BHP's steelworks at Newcastle.

1923 - Lead/zinc orebody discovered at Mt Isa (Qld).

1924 - Oil and gas produced from well at Lake Bunga in eastern Gippsland, near lakes Entrance (Vic).

1926 - Aberfoyle tin and wolfram deposits located in Tasmania.

1934 - First commercial development of mineral sands deposits at Byron Bay (NSW).

1937 - First large-scale mining of black coal by open-cut methods in Australia at Blair Athol (Qld).

1943 - Large-scale production of zircon/rutile concentrate from Queensland. Large-scale production of asbestos at Wittenoom Gorge (WA).

1944 - Extensive open-cut mining at Leigh Creek (SA) coal started.

1948 Wundowie (WA) charcoal iron and steel industry began production.

1949 Uranium discovered at Rum Jungle (NT).

1950 Bauxite discovered at Gove (NT).

1951- First shipment of iron ore from Yampi Sound (WA) to Port Kembla steelworks in NSW.

1953 - Flow of oil discovered in WAPET's Rough Range No. 1 well at Exmouth Gulf (WA) provided stimulus for continuing search in ensuing years.

1954 - Rum Jungle (NT) uranium plant opened.

1956 - Full-scale mineral sand mining began at Capel (WA).

1961 - Flow of oil in Moonie No. 1 about 80km from Tara (Qld). Australia's first commercial oilfield by Union/Kern/AOG group on a field around this well.

1962 - Iron ore deposit identified at Mt Tom Price (WA). Manganese discovered on Groote Eylandt (NT).

1963 - Mining of Darling Range (WA) bauxite began.

1964-65 - Discovery of gas and oil in the Bass Strait (Vic).

1965 - Discovery of Mitchell Plateau (WA) bauxite deposits.

1966 - Discovery of nickel at Kambalda (WA) and phosphate at Duchess (Qld). Iron ore mining began at Mt Tom Price and Mt Goldsworthy (WA), first iron ore exports from WA.

1967 - Discovery of Mt Weld (WA) carbonatite containing rare earths and phosphate. Discovery of Woodcutters (NT) lead/zinc prospect. Start of mining of Savage River (Tas) iron ore deposit.

1969 - Discovery of nickel at Mt Windarra (WA) and start of Poseidon boom. Discovery of Woodlawn (NSW) base metal deposit.

1970 - Discovery of Eneabba (WA) mineral sand deposits.

1970-73 - Ranger, Nabarlek and Jabiluka (NT) uranium deposits found.

1971 - Discovery of Agnew (WA) nickel deposit, Telfer (WA) gold deposit, start of iron ore production at Robe River (WA) and the discovery of Yeelirrie (WA) uranium deposit.

1971-72 - Discovery of North West Shelf (WA) natural gas fields.

1979 - Natural gas discovered at Port Campbell (Vic). Discovery of diamonds in Kimberley region of WA. Discovery of Granny Smith (WA) gold deposit.

1983 - Hellyer (Tas) base metal deposit discovered.

1985 - Discovery of Kintyre (WA) uranium deposit. Discovery of Kunwarara (Qld) magnesite deposit.

1985-1989 - Many old gold mines in WA revived as open-cut operations.

1987 - First production from Cadjebut (WA) lead/zinc deposit.

**APPENDIX No.5****Appendix No. 5:- Timeline of Australian Mine Deaths (1882-1991)**

<b>MINE</b>	<b>STATE</b>	<b>YEAR</b>	<b>TYPE OF INCIDENT &amp; No. of Deaths ( )</b>
Creswick Gold Mine	VIC	1882	Mine flooded (22)
Bulli Colliery	NSW	1887	Explosion (81)
Mount Kembla	NSW	1902	Explosion (94)
Mount Mulligan	QLD	1921	Coal dust explosion (76)
Bellbird Colliery	NSW	1923	Fire & explosion (21)
Metropolitan Colliery	NSW	1925	Outburst of CO2 (2)
Redhead Colliery	NSW	1926	Gas explosion (5)
Hart's Aberdare	QLD	1936	Gas explosion (4)
Wonthaggi Mine	VIC	1937	Explosion (13)
Ebbe Vale No 3	QLD	1945	Gas explosion (4)
Aberdare Extended	QLD	1954	Gas explosion (2)
Metropolitan Colliery	NSW	1954	Outburst of CO2 (2)
Collinsville Mine	QLD	1954	Outburst of CO2 (7)
Bulli Colliery	NSW	1965	Underground fire (4)
Wyee State Colliery	NSW	1966	Fall of roof (5)
Blockman's Flat	NSW	1972	Fall of roof (3)

Box Flat Ipswich	QLD	1972	Gas & dust explosion (17)
Kianga Mine	QLD	1975	Gas & dust explosion (13)
Agnew Mine	WA	1977	Fall down shaft (5)
Leichhardt	QLD	1978	Gas outburst (2)
Appin Colliery	NSW	1979	Explosion (14)
Laleham No 1 Colliery	QLD	1982	Fall of roof (3)
Moura No 4 Mine	QLD	1986	Explosion (12)
Emu	WA	1989	Mine flooded (6)
Western Main	NSW	1991	Roof fall (3)
South Bulli Mine	NSW	1991	Gas explosion (3)
Moura No 2 Mine	QLD	1994	Explosion (11)
Gretley Colliery	NSW	1996	Shaft flood (4)

Mine disasters in Australia, 1882–1996.

Compiled from Dept of Mineral Resources in various states

**Appendix No. 6:- Extracts of MSI 1994 – Part 7 Sect 75-79**

**75. Health surveillance of mine employees**

*(1) The principal employer and every employer at a mine must establish and maintain a system for the surveillance of the health of their employees in accordance with the regulations*

*(2) The principal employer and every employer at a mine must provide information to the State mining engineer on the surveillance of the health of their employees in accordance with the regulations.*

**76. Notice of accident to be given**

*(1) Where a person suffers injury in an accident at a mine and is disabled by that accident from following his or her ordinary occupation, the manager must cause notice of the accident to be given ?*

*(a) in accordance with the regulations, to the district inspector for the region in which the mine is situated; and*

*(b) if the injured person so requests, to the secretary or local representative of a trade union of which that person is a member.*

*(2) The notice required to be given under subsection (1) must ?*

*(a) if the injury appears to be serious, be given by the fastest practicable method of communication as soon as it is reasonably practicable to do so, and must subsequently be confirmed in writing; and*

*(b) if the injury appears not to be serious, be given in writing at the end of the month.*

*(3) A manager who ?*

*(a) omits to give a notice required to be given by subsection (1); or*

*(b) fails without reasonable excuse to give a notice required to be given by subsection (1) in accordance with subsection (2), commits an offence, unless the required notice was given by the principal employer at the mine.*

*(4) An injury is a serious injury for the purposes of this section if the injury ?*

*(a) results in the injured person being disabled from following his or her ordinary occupation for a period of 2 weeks or more; or*

*(b) involves unconsciousness arising from inhalation of fumes or poisonous gases or asphyxiation due to lack of oxygen or displacement of oxygen by an inert gas; or*

*(c) results from an accident, including fuming, arising out of the use of explosives or blasting agents.*

**77. Recording of accidents in accident log book**

*(1) The manager must cause to be kept at the mine a book of a type approved by the State mining engineer and called the accident log book, and must after the occurrence of any accident cause a record of the accident to be entered without delay in the book. Penalty: \$5 000.*

*(2) The manager must ensure that the accident log book is kept open at all reasonable times to the examination of an inspector, an assistant inspector, a safety and health representative for the mine, a representative of a trade union any member of which is employed at the mine, and of any other person authorized by the State mining engineer. Penalty: \$5 000.*

**78. Recording of occurrences in the record book**

*(1) The manager must immediately give notice to the district inspector for the region in which the mine is situated of an occurrence to which this section applies, whether or not any bodily injury to any person or damage to property has resulted from the occurrence and must give to the district inspectorsuch particulars in respect to the occurrence as the inspector may require. Penalty: \$5 000.*

*(Refer to the Act for further details)*

**79. Manager to report potentially serious occurrences**

*(1) The manager inform the district inspector for the region in which the mine is situated of any occurrence at the mine which in the manager's opinion has the potential to cause serious injury or harm to health (other than an occurrence referred to in section 78) although no injury or harm in fact happened. Penalty: \$5 000.*

*(Refer to the Act for further details)*



**Appendix No. 4:- WA and Australian Petroleum Act and Regulations**

**COMMONWEALTH ADJACENT AREA**

Schedule of Specific Requirements as to Offshore Commonwealth – Petroleum Submerged Lands (SL) Act 1967

Schedule 7 – Occupational Health & Safety (part Petroleum Exploration & Production 1995 (with amendments 1SL/1996-7 and 2SL/1996-7 )

Petroleum Submerged Lands (Management of Safety On Offshore Facilities) Regulations 1996.

**WESTERN AUSTRALIA COASTAL WATERS**

Western Australia - Petroleum (Submerged Lands) Act 1982

Schedule of General Requirements for Occupational Health & Safety 1993 ( the "green book")

Schedule of Specific Requirements as to Offshore Petroleum Exploration & Production 1995 (with Amendments 1T/96-7 and 2T/96-7)

**WESTERN AUSTRALIA ONSHORE**

Western Australia – Petroleum Act 1967

Schedule of General Requirements for Occupational Health & Safety – 1993 (the "green book")

Schedule of Onshore Petroleum Exploration & Production Requirements 1991 For Submerged Lands

**WESTERN AUSTRALIA PIPELINES**

Petroleum Pipelines Act 1969 (including Regulations 1970)

Schedule of General Requirements for Occupational Health & Safety – 1993.

Schedule of Onshore Petroleum Exploration & Production Requirements 1991

Appendix No. 8:- MINESAFE – MOD MAGAZINE



# MINESAFE

ISSUED BY THE MINING OPERATIONS DIVISION OF THE DEPARTMENT OF MINERALS AND ENERGY(WA)

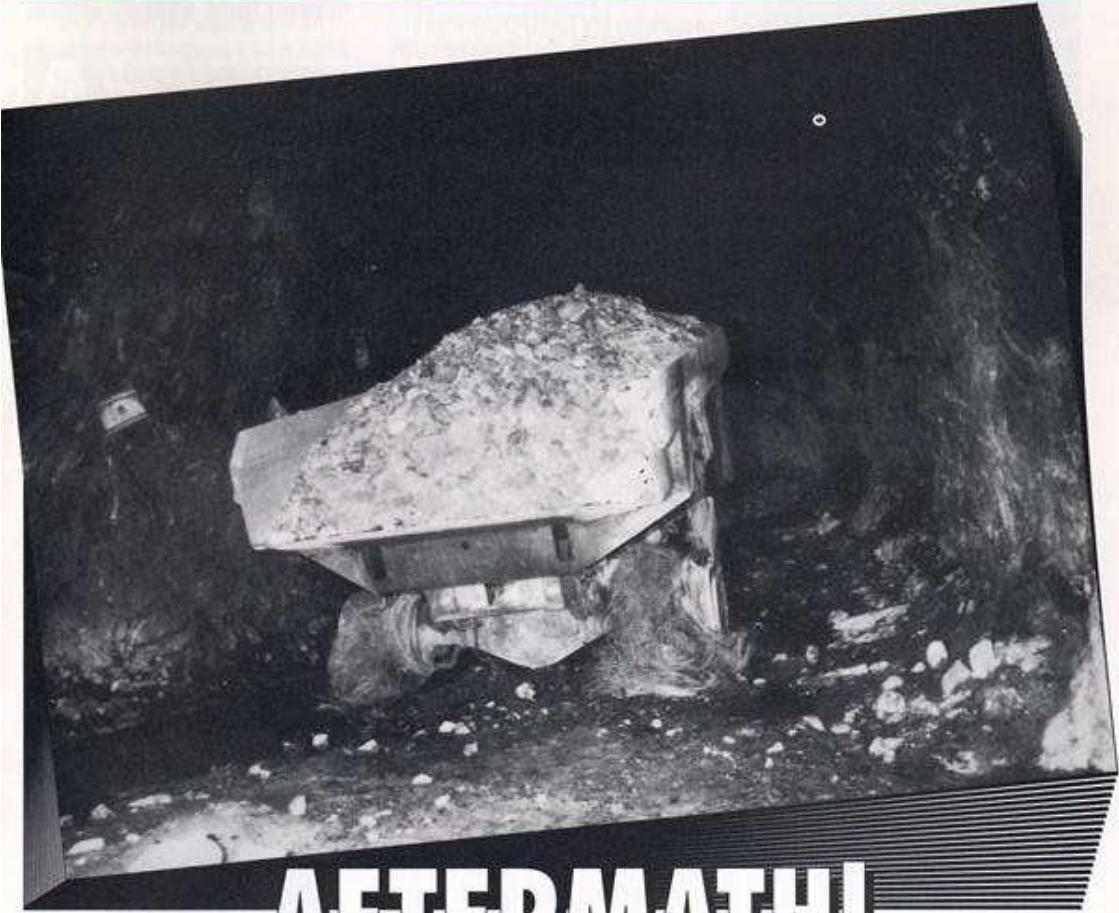

## AFTERMATH!

A 40 tonne articulated haul truck caught fire when the right hand rear wheel brake locked coming up the decline. The brake system overheated, and caught fire. The blaze spread to the front of the truck via the hydraulic oil lines, burning out the engine compartment, cabin and the hydraulic system. No one was hurt, but the potential danger was extreme, particularly for those people working downwind of the blaze.

JUNE 1994

Vol.5 No.2

1

## APPENDIX No.9

### **Appendix No. 9:- Brambles vs Others, Supreme Court of W.A., 1994.**

*SUPREME COURT OF WESTERN AUSTRALIA, FILE NO/S : CIV 1961 of 1994*

*BETWEEN : BRAMBLES AUSTRALIA LTD Plaintiff AND*

*AM & JP KEUNE PTY LTD First Defendant, IAN ROBERT JONES Second  
Defendant*

*HEARD: 9-12 FEBRUARY 1998, DELIVERED: 26 FEBRUARY 1998*

*Extract from Transcript*

*Mr Jones' evidence was tested theoretically by Mr David Axup, also a well qualified motor vehicle accident consultant with considerable experience. Mr Axup, in conjunction with an organisation known as ARRB Transport Research Ltd ("ARRB") used a [computer model] to simulate the collision as described by Mr Jones.....*

*As Mr Axup acknowledged, this approach is subject to the limitations of the computer program and the assumptions, which it makes. These included a perfectly smooth road of infinite width. Further, it was assumed for the purpose of the simulation that the Brambles prime-mover had a single steer axle. It will be recalled that it actually had a double steer axle.*

*The computer simulation demonstrated that it would have been possible for the two road trains to have executed the movements as described by Mr Jones in the time available. However, it is apparent from the ARRB report that the road trains would have been at the limit of their stability. (WASC, 1998)*

## APPENDIX No.10

### Appendix No. 10:- Administrative Appeals (Planning), Victoria, 1994

ADMINISTRATIVE APPEALS TRIBUNAL OF VICTORIA, PLANNING DIVISION

APPEAL NO: 1994/31912, APPLICATION NO: 8161

HEARD AT MELBOURNE ON 11TH OCTOBER 1994, AND

AT BENALLA ON MONDAY 14, 15 AND 16 NOVEMBER 1994

TRIBUNAL: Anthony Liston, Presiding Member Gerard Sharkey, Member

PARTIES: Appellant/Objectors Peter Hall and Others

Responsible Authority Shire of Delatite (formerly City of Benalla)

Respondent/Applicant Shire of Delatite

NATURE OF APPEAL - Appeal under Section 82 of the *Planning and Environment Act* 1987 (the Act) against a decision to grant a permit.

Extract from Transcript

#### PROPOSAL

Development of a multi-purpose Sport & Recreation Centre incorporating: indoor heated swimming pool, exercise rooms, change rooms, clubrooms, incl. licensed club facilities and in excess of 20 gaming machines & gaming facilities.

Removal of native vegetation to facilitate the development.

Relocate sheep pens and horse stall.

-----

Structures within the floodplain obstruct the flow of water and can increase the flooding impact of particular flows in that locality. Dr. Phillips is a consultant engineer who has been working with the City of Benalla to develop a better floodplain management plan in response to the effects of the 1993 floods. Willing and Partners have developed a **[computer model]** of the behaviour of the

floodplain in flood conditions. The Responsible Authority requested Dr. Phillips to assess the impact of the proposed development using this model, set out below is the conclusion from Dr. Phillips' evidence resulting from this assessment

*It was concluded that if the Sport and Recreation Centre had been already constructed at the time of the 1993 flood then it would have lead to a small increase of up to 0.04m immediately upstream of the Centre. The potential increase in flood levels in the vicinity of residential properties in Arundel Street and elsewhere would be further reduced by the distance of residential buildings from the Centre which it is proposed to construct adjacent to the Showgrounds on the left bank of the Broken River It was further concluded that the estimated increase in peak flood levels during an October 1993 flood, which was a severe flood, of less than 0.1m during major floods is acceptable in hydraulic terms."*

It is true that **[computer models]** are inherently uncertain but it is also true that in this case the assessment is conservative because it makes no allowance for the permeability of the under structure of the building, the removal of buildings from the floodplain in association with the development, and the relocation of other buildings into the lee of existing buildings. The Tribunal is satisfied that the impact of the proposed building on floodplains in this location is sufficiently marginal to be disregarded. (VICAAT 1994)

**Appendix No. 11:- Queen vs Challoner, Supreme Court of Victoria, 1996**

*SUPREME COURT OF VICTORIA, COURT OF APPEAL, No. 176 of 1996*

*THE QUEEN v. MICHAEL JOSEPH CHALLONER*

*JUDGES: PHILLIPS, C.J., CALLAWAY and KENNY, J.J.A.*

*WHERE HELD: Melbourne*

*DATES OF HEARING: 30-31 March, 7, 8 and 20 April 1998*

*DATE OF JUDGMENT: 28 July 1998*

-----

The witness continued that on the basis of the above information, and no more, he prepared a computer model with the intention of producing a reconstruction of the scene using three dimensional [**computer graphics**], rather than simply a plan. All this was in an attempt to ascertain the likely path of the bullet which struck the deceased.

-----

At this point, and without objection, a "video [**animation**]", Exhibit "G" was tendered. An attempt to play the video failed for technical reasons but it is clear the jury had already viewed it during the opening address of counsel for the prosecution. Mr Ogleby continued his evidence. In answer to the prosecutor, and apparently referring to the video, he said he had produced a "cone of probability" which he described as, "my expression".

The final outcome was the following

The application for leave to appeal against conviction is granted, the appeal treated as instituted, heard *instanter* and allowed. The conviction sustained by the applicant in the court below is quashed and the sentence imposed thereon is set aside. The Court directs that a new trial of the applicant be had

**Appendix No. 12:- Toomey vs Scolaro, Supreme Court of  
Victoria, 1997**

*SUPREME COURT OF VICTORIA,*

*Toomey v Scolaro Concrete Constructions and Others (No.2) - No. 4130 of 1997*

*JUDGE: Eames J*

*Dates of Hearings: 12 - 16; 19 - 23; 26 - 28 February 2001; 1, 2, 5 - 9, 13 - 16, 19 - 23, 26 - 30 March 2001; 2 - 4, 18, 23, 24, 26, 27, 30 April 2001; 1 - 4, 7, 8, 16 - 18, 21 - 25 May 2001 Date of Judgement: 17 August 2001 - Medium Neutral Citation [\[2000\] VSC 279](#)*

-----  
**NEGLIGENCE** - Damages - plaintiff falls over balustrade within stairwell in block of flats - whether height of balustrade in breach of clause D2.16 Building Code of Australia 1990 - whether low balustrade nonetheless served "to restrict" falls - .....- whether delegable and/or non-delegable duty of care owed

causation - whether fall solely due to skylarking of colleagues of plaintiff on stairway - plaintiff severely intoxicated - volenti non fit injuria -

.....- quantum of damages - plaintiff quadriplegic - 25 year old, world-class athlete at time of injury - loss of earning capacity - whether benefits allowed to family business on account of plaintiff's labour were earnings of plaintiff - relevance of pension repayable to Commonwealth.

-----  
Anatomist, Mr Donald Meikle, and bio-mechanist, Mr Noel Lythgo, after visiting the site of the accident, produced a video [**computer animation**] and also video taped a number of demonstrations, in a controlled environment, of situations where a subject was subjected to varying forces against bars at 1000 mm and 933.5mm. They also took anthropometric measurements both of the plaintiff and of the claimed scene of the accident. Mr Meikle stressed the significance of the reduced height of the bar when set against the body of the plaintiff. (VICSC, 1997)



**Appendix No. 13:- Longford Royal Commission, Victoria, 1998**

The Esso Longford Gas Plant Accident

Report of the Longford Royal Commission

The Honourable Sir Daryl Michael Dawson, AC KBE CB – chairman

Mr Brian John Brooks, BE FIEAust FAIP FAIE FIE – Commissioner

No 61 – Session 1998-99, Parliament of Victoria

stresses. A temperature difference of the order of 20°C would have been sufficient to result in the failure on 25 September 1998.

6.26 The modelling method used was finite element analysis. The model calculated the stress in the tubesheet to channel weld due to the stresses induced by the internal pressure and a temperature differential between the channel and the shell. The residual stresses were ignored, as they were small in comparison. The model accepted the shell side being uniformly warmer than the channel of the reboiler, as shown in Figure 6.18. The temperature difference would cause the shell side to expand to a larger diameter than the channel, resulting in stress in the tubesheet to channel weld.

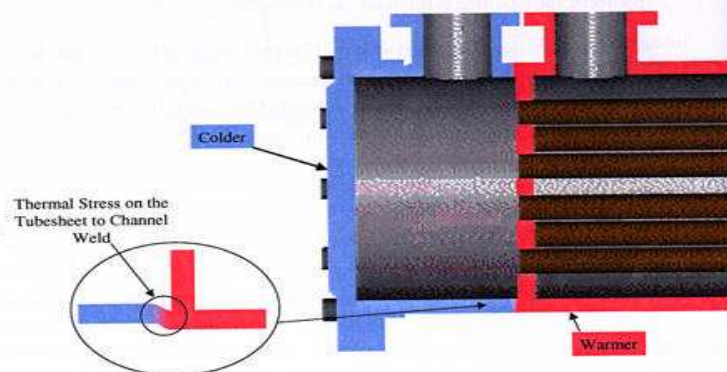

Figure 6.18 Finite element model for GP905 thermal stress calculations

6.27 The model calculated the axial stresses for the internal pressure and the 1°C temperature difference in the tubesheet to channel weld. The initial model was enhanced to a 3D model that evaluated the effects of the nozzles on the stress. The nozzles were found to have little effect on the stresses in the tubesheet to channel weld.

6.28 Having determined the stress to temperature relationship, the next step taken was to assess the temperature difference required for an initiating flaw to result in the failure of the vessel.

6.29 The cases modelled were based on the possible flaws identified by the investigation of the failure surface at the 8 o'clock position. The set of cases developed for the modelling of stress were:



### 3D Modelling Cases

- A flaw the size of the flat region found at the 8 o'clock position (ignoring the weld root cavity). This was modelled as a semi-elliptical flaw 18 mm long by 7 mm deep, using a 3D model.
- A combination of a flaw the size of the flat region and the weld root cavity. This was modelled as a semi-elliptical flaw 120 mm long by 7 mm deep. The weld cavity was 230 mm long, so this flaw was conservative in length.
- A combination of a flaw the size of the flat region and the weld root cavity. This was modelled as a semi-elliptical flaw 180 mm long by 7 mm deep. The weld cavity was 230 mm long so this flaw was a better, but still conservative, estimate of the length.
- A small flaw at the weld root cavity. This was modelled as a semi-elliptical flaw 70 mm long by 3 mm and by 4 mm deep (2 cases). The weld cavity was 230 mm long, so this flaw was a better, but still conservative, estimate of the length.

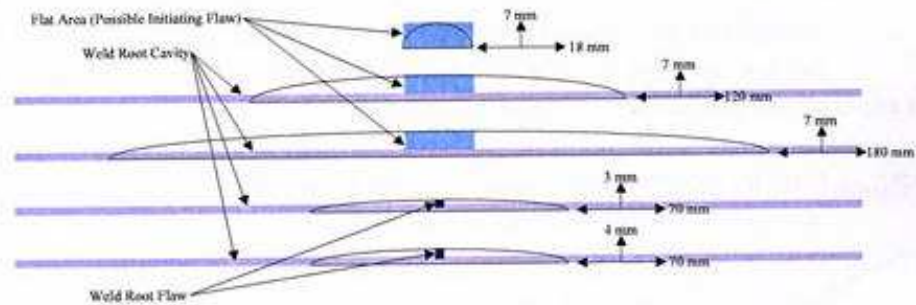

Figure 6.19 Flaw cases for 3D modelling

### 2D Modelling Cases

- Long rectangular flaws of depths 2 mm, 4 mm, 6 mm, 7 mm and 8 mm. The depths were chosen to represent the range of depths of potential flaw from that to the weld root cavity to the flat area.

For each of these cases, the stress intensity factor was calculated and was compared to the fracture toughness values obtained from the tests. This comparison enabled cases that could result in failure to be identified.

The results of the failure analysis found the following:

## Appendix No. 14:- Rolling Rocks Brochure

# Rolling Rocks

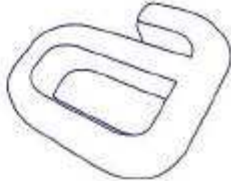

**Friday 24th May...**

...Buzard Open Pit Mine, John David Spicer suffers serious injuries in an incident involving a haul truck."

"The seat belt on the passenger seat had been removed for maintenance two days previously."

"As the truck reversed to the edge of the stockpile it collapsed under the rear wheels and the truck slipped over the edge and came to rest on the ground some six metres below."

"Mr Spicer sustained a fractured skull, three fractured ribs and a compound fracture of the right arm."

The "Rolling Rocks" training package, currently under development at AIMS Solution (in association with Central TAFE, WA) is based on information from the Department of Minerals and Energy (Western Australia).





This new concept in training from AIMS Solutions mixes forensic animation, accident case studies, responsibility assessment, multi-media safety training and interactive hazard spotting.

The package integrates computer generated animation, live action video and virtual reality simulation with easy to use, browser based interactivity. This provides a learning experience which will stimulate your work force and make their training an interesting and enjoyable experience.

A prototype of this product will be premiered at Minesafe International 2000 in Perth, Western Australia.

AIMS Solutions would welcome your comments and feedback

Contact us at the address shown below.



**aims solutions**  
[aims-solutions.co.uk](http://aims-solutions.co.uk)

AIMS Solutions Ltd PO Box 6345 Nottingham U.K. NG7 2XN Tel 0115 951 4321 Fax 0115 9466392

Partnered by 

## **Appendix No. 15:- Letter from Mr Ken Steele**



**Drillmark Consultants & Assocs**  
**143 Lesmurdie Rd, Lesmurdie, WA 6076**

3/7/02

### **Karpa Springs Animation**

Dear Ken

The Karpa Springs gold fraud case had a high profile in WA when it was being prosecuted through the courts. The case involved three prospectors whom, it was alleged, had salted a prospect to the extent that it was identified as having the potential to become Australia's richest mine. The prospectors sold out their interest in the prospect to a mining company for a substantial sum of money. The tenement was subsequently found to be barren with no gold in place beyond minute background levels normally associated with such geological formations.

Drillmark Consultants was engaged by the defense and asked to examine all of the evidence and identify any possible explanations for the discrepancies, which had been accomplished in the exploration drilling process.

From my initial examination of the evidence I took the view that the prospect was indeed barren, a view not shared by the accused.

My preliminary report drew attention to certain aspects of the evidence, which I believed could indicate the drill and the drilling process as having potential involvement in the salting process. This conflicted with a good deal of the sworn statements provided by the prosecution in support of their case against the three accused in which it was inferred that the prospectors had more likely introduced the salted gold into the samples subsequent to the drilling process.

It was my preliminary opinion that there were aspects of the evidence which, when considered in relation to each other, could demonstrate this not necessarily to be the case. I felt that the drill and the drilling process could potentially be used to achieve the same apparent effect as that illustrated in the sample values and random distribution of gold provided through subsequent laboratory fire assay analysis of the drill samples.

Central to my opinion was the specific type of drilling which had been employed and the equipment used in the process. This involved the use of a down hole hammer with a cross over sub using a drilling technique termed RAB or rotary air blast drilling.

In this system the down hole hammer and the drill bit are powered by compressed air and used in tandem with dual wall drill pipe. To penetrate the subsurface geological formations and deliver samples of the ground being penetrated through the inner drill pipe back to the surface for collection and sampling.

The down hole hammer is essentially a high speed reciprocating piston running inside a cylinder and striking the drill or cutting tool several hundred times a minute.

Because of the close tolerances the down hole hammer system requires a specially formulated oil to be introduced into the air stream to lubricate the piston/inner cylinder surface. It was my preliminary opinion that this could have provided the means of introducing the salted gold.

I could find no evidence of this having been previously demonstrated but outlined the mechanisms and processes by which I felt this could be achieved.

The industry has three separate methods of introducing oil into the air stream two of which employ a reservoir of oil to be mechanically collected through the air stream supply and the third being manually pouring oil into the system at each interval that the drill was stopped to extend the depth by adding another length of drill pipe.

It could not be determined through the available evidence which specific system had been employed by the drilling contractor at the time the exploration took place.

In my preliminary opinion I postulated that had such a mechanism been employed this could also link in with other aspects of evidence such as "random flyers" or isolated gold particles found during the subsequent drilling activities which were undertaken by the police at the request of the prosecution and which subsequently the prospect as being otherwise barren.

From my reading of the evidence, the focus of the prosecution's allegations was that the samples had been tampered with after recovery through drilling process but my brief was not required to examine this aspect and indeed would have been outside the area of my expertise.

My opinion whilst not excluding the accused from involvement, if it could be demonstrated to work in practice, would indicate the potential for parties other than the three accused to have been involved and that this could have been accomplished without their knowledge or involvement.

Specifically I was asked to identify possible avenues by which the fraud could have perpetrated and to carry out field based experiments under controlled conditions which would test the practicality of the theoretical explanations I had advanced.

On the basis of my opinion, I was engaged to carry out field trials to investigate if my theories would work in practice.

To achieve this I engaged the services of two different drilling contractors using the three different oil distribution mechanism previously identified to drill sample holes in three non gold bearing formations.

In each case the drill samples were collected in the conventional manner to be taken through the same laboratory analytical process as the original samples to determine the content or absence of gold.

In order to preserve the forensic nature of the investigation it was necessary to employ subterfuge to ensure that all third party involvement was excluded from the actual drilling activity.

The two owners of the drilling rigs were the only persons with knowledge of the objectives of my research trials and they were each required to sign a legal non disclosure agreement document prior to leasing their rigs to me and were not to be present when the trials were conducted.

The drilling crews were told that I was conducting trials of a new oil formulation for use with a down hole hammer system and that the oil had a vegetable dye additive to trace its content in the samples being obtained. The purpose of the trial being to test the oil content and possible contamination in surrounding formations should it be used in water well drilling applications. This provided further explanation to the crew of why the drill oil mechanisms were to be sanitized after the drilling had been completed.

I was the sole person in charge of the oil supplied to the drilling crew prior to the commencement of drilling and to which I had added a small supply of gold and large quantity of a vegetable die.

The drilling crew used the oil in the conventional manner and gathered the drill return samples in exactly the same way as would be the case on an exploration site, splitting the samples, providing 25 percent of the return to myself bagged as they would be for transport to the laboratory for analysis.

I transported the samples direct to the laboratory for them to analyse in the same manner as the originals, with the results to be sent directly to the legal team of the accused.

The three trials each produced a result, which demonstrated the viability of the system as a means of introducing gold into a sample through the drilling process.

It was held to be significant that the most successful of the three trials and the one which replicated the original data in the manner in which the spurious gold was randomly dispersed both in content and depth, was achieved by using a rig of identical manufacture to that used on the Karpa Springs prospect. Whilst not conclusive this rig would have possibly the identical mechanical oil distribution system supplied by the manufacturer as a part of the original equipment.

By the time I was called to give evidence at the trial, the case had been in session for several days and the jury had been provided with a mass of technical information to consider. In order to provide sufficient background information for the jury to support my evidence it was necessary to add to this and explain in detail the drilling process and its various complexities before I could hope to have them understand the core issues which my field trials had identified. The only method available to me was through a series of photo-copied diagrams and my verbal explanations.

As a personal observation I felt I was failing to get through to the jury being just one more in a long line of technical experts providing complex opinions information which would be totally alien to the average juror.

Cross examination demonstrated to me that my findings were not lost on the prosecution and they exploited the juror's probable failure to grasp the essentials of my findings as would be expected where the evidence was contradictory to their case.

The accused were found guilty, have by now served their sentence and are still suffering the consequences of what I believe to be an unsafe conviction if there were no other contrary evidence other than results of my field trials.

The three parties have been given leave to appeal their conviction and as a part of new evidence my findings will come before the courts again for re examination.

The use of computer graphics which animate the drilling process and enable the inter related and interactive aspects of the drilling process and sample delivery to be visually demonstrated will greatly enhance the ability of the judiciary to grasp the complexities involved and follow the logic on which my part of the evidence is based.

In this format the drilling equipment, the system and the interference with the formation can be illustrated and interrogated to ensure total comprehension and conformity with the original findings presented at the initial trial.

The technology employed to produce this animation was not available at the time and in my opinion should prove invaluable in demonstrating complex technical issues to non technical personnel.

My involvement with the development of this animation has heightened my awareness of the potential power of this technology in the wider field of training in general.

In its current form apart from its use in the court room, the functionality of the animation lends itself to explaining to trainees and indeed current practitioners of precisely what happens down the hole whilst conducting exploration drilling activities and how the various pieces of equipment such as down hole hammers, cross over subs, dual wall drill pipes and cyclones operate and interact to perform their individual functions.

This is not always truly understood with any exactitude even by experienced operators since they are trained to react to surface information feedback through either gauges or noise. Learning by rote in this manner leads a great deal to be desired. Whilst it develops

practical skills, the underpinning knowledge and theories behind the technology remain a mystery to many.

This gap in their training means that drill crews are, in many instances unable to operate at maximum productivity potential, when confronted with conditions they have not previously encountered and the learning curve can be quite extensive.

By definition, exploration infers encountering and entering the unknown. Drilling into geological formations associated with gold is substantially different to drilling into formations associated with other base metals. Although the equipment performs the various functions in the same way, until the drill crew recognise and react to the differences in which the ground conditions react, both productivity and in some cases the accuracy of the drill sampling can suffer. From the industry perspective it is far better to have drill crews trained with more universal skill sets and the use of computer graphics lends itself to this.

The concept of using this animation and others like it linked into a drilling rig control panel could present a training aid with substantial application in the field of training and one which industry would embrace with enthusiasm were it to be commercially available.

I thank you for the work you have undertaken on this project and which I hope will continue to advance the use of this technology into industry applications.

Sincerely

Ken Steele



Appendix No. 16:- UDR Drill rig information

# UNIVERSAL DRILL RIGS



## Universal MkII 650 Drill

# Universal MkII 650 Drill

## Description — Specifications

<b>Type</b>	All hydraulic top head drive.	<b>Rod Clamps &amp; Slips Table</b>	B†, N† and H† Rod clamp jaws, hydraulically operated and self energising. Range of optional jaws available from 44.5 mm (1 3/4 in) to 177.8 mm (7 in). 320 mm (12 5/8 in) Mast bottom opening. 224 mm (8 7/8 in) Rod clamp body opening. NOTE: † Refers to "O", "Q" & "T" or similar wireline systems.		
<b>Drill Mast</b>	6 m (20 ft) Rod pull capacity, 9.2 m (30 ft 2 in) long. Designed for angles between vertical and 45°. 720 mm (2 ft 4 in) hydraulic mast dump. Mast can reach ground level between 60° and 90° drilling angle.	<b>Wireline Winch</b>	1000 m (3280 ft) of 5 mm (3/16 in) wire rope. Full drum pull: 3.4 kN (765 lbf) at 243 m/min (797 ft/min). Bare drum pull: 7.6 kN (1750 lbf) at 101 m/min (331 ft/min).		
<b>Diesel Motor</b>	GM4-53T, 116 kW (155 hp) at 2200 rpm.	<b>Hydraulics</b>	Highest quality axial and radial piston pumps and motors used in three independent open circuits (Main — Water — Cylinders). Full flow 10 micron beta rated return oil filtration. Larger than average hose and control valve sizes used to achieve highest possible circuit efficiency. Proven reliability over thousands of hours can be demonstrated.		
<b>Rotation Head</b>	Top drive direct coupled. High-low manual gear change. High precision helical gears, case hardened and ground, 5–1700 rpm. Stepless speed control 5–380 rpm in low gear and 380–1700 rpm in high gear. <b>Output Torque at 100% efficiency:</b> 5095 Nm (3755 ft lbf) 5–100 rpm 505 Nm (373 ft lbf) 1000 rpm 298 Nm (220 ft lbf) 1700 rpm Fully automatic torque-speed control for diamond drilling running the bit always at highest possible rpm using maximum available horsepower. 48 mm (1 7/8 in) ID hollow spindle, floating 50mm (2 in). Jet-lubricated gears and bearings. Air to oil type lube oil cooler fitted.	<b>Rod Carry Rack</b>	Tray type for 6 m (20 ft) lengths of drill pipe situated on the right hand side of the drill tray. Nominal capacity 20 x 6 m (20 ft) lengths of 89 mm (3 1/2 in) pipe.		
<b>Head Traverse</b>	Hydraulic cylinder over pull down ropes and pullover chains, 2:1 ratio. 6.66 m (22 ft) traverse with maximum speeds of 41.9 m/min (137 ft/min) up, and 29 m/min (95 ft/min) down. Hydraulic side racking of rotation head.	<b>Pipe Boom</b>	Hydraulic fully variable and swivelling pipe handling boom for all angles from vertical to 45°. Loads and unloads from rod carry rack or from back up truck.		
<b>Pull Down</b>	45 kN (10,000 lbf) - cylinder over ropes.	<b>Depth Capacity</b>			
<b>Pull Out</b>	75 kN (16,800 lbf) - cylinder over chains.	<b>Drilling Techniques</b>	<b>Hole ø</b>	<b>Rode</b>	<b>Depth</b>
<b>Rod Pull</b>	6 m (20 ft).	1. High pressure down the hole hammer drilling and rotary non core, mud or air flush:	165 mm 6 1/2 in	89 mm 3 1/2 in	300 m 1000 ft
<b>Main Hoist</b>	64.9 kN (14,600 lbf) maximum pull. 120 m/min (394 ft/min) maximum speed. Mast top mounted, single line pull. Fully automatic pull-speed control pulling the rodstring always at highest possible speed using maximum available horsepower.	2. Diamond core:	B† 1000 (3900)	N† 670 (2850)	H† 575 (1885)
<b>Water Pump</b>	Bean W1122BCD-140 L/min at 7000 kPa (37 gpm US at 1000 psi). Option: Bean pump with disc valves. Standard hydraulic transmission can then produce 190 L/min at 7000 kPa (50 gpm US at 1000 psi) water output.	NOTE: Diamond drill depth capacities based on straight, vertical, clean and fluid filled holes. No allowance made to break core. † Refers to "O", "Q", "T" or similar wireline systems.			
<b>Rod Break Out</b>	Hydraulic 48 in Rigid Stillson. 7500 Nm (5528 ft lbf) make-up torque at 12000 kPa (1740 psi) 7500 Nm (5528 ft lbf) break-out torque at 8000 kPa (1160 psi).	<b>Approximate Weight and Dimensions:</b> Bare drill on hydraulic jack-up tray Weight: 8 100 kg (17 800 lb) Length: 9.2 m (30 ft 2 in) Width: 2.5 m (8 ft 2 in) Height: 3.5 m (11 ft 6 in)			

Specifications are as at March 1995 and are subject to changes or modifications without notice which are made from time to time by U.D.R. and its suppliers in accordance with their policies to update and improve their products.

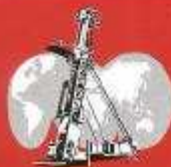

## UNIVERSAL DRILL RIGS

A TRADE NAME OF UNIVERSAL DRILLING SYSTEMS (AUST.) PTY. LIMITED  
(INCORPORATED IN THE STATE OF QUEENSLAND)

100 Grindle Road  
Rocklea 4106  
Queensland  
Australia

PO Box 204  
Salisbury 4107  
Queensland  
Australia

Telephone (07) 3875 1177  
International 61 7 3875 1177  
Fax (07) 3875 1919



## **Appendix No. 17:- Introduction to the Safety Case Concept**

### **Introduction to the Safety Case Concept**

The term "safety case" is used to describe a sophisticated, comprehensive and integrated risk management system. A safety case regime is characterised by an acceptance that the direct responsibility for the ongoing management of safety is the responsibility of the operators and not the regulator, whose key function is to provide guidance as to the safety objectives to be achieved. The operators can achieve those objectives by developing systems and procedures that best suit their needs and agreeing these with the regulator. This "safety case" then form the rules by which the operation of the facility is governed.

The safety case includes details of safety management arrangements and risk assessment studies, which, once submitted to and accepted by the regulator, form a co-regulatory guidance document that sets both the standards to be achieved and the mechanism for achieving them.

The safety case also forms the basis for ongoing audits of the facility and its operation throughout its life. Key aspects of inspection/auditing by the regulator will be to monitor the effectiveness with which the commitments in the safety case are being implemented, monitor the effectiveness of both the safety management system (SMS) and the operators audits of them, and to critically examine the efforts made by management to actively involve the workforce in the safety case process.

The concept was developed in the United Kingdom to minimise major industrial hazards, mainly in the nuclear and chemical industries, and is now used to manage risk in a wide variety of applications. These include the control of risk in British naval operations, the safe operation of the privatised British railway system and the design of computer software programs. The safety case regime is normally based on a 'co-regulatory structure', with an 'operator' preparing and operating the facility for which the safety case is developed and a 'regulator' assessing, accepting and auditing the adequacy of the safety case.

A safety case serves two main purposes:

to give the 'regulator' (assessor) confidence that the 'operator' has the ability, commitment and resources to properly assess and effectively control risks to the health and safety of staff and the general public; and

to provide a comprehensive working document against which the 'operator' and the 'regulator' can check that the accepted risk control measures and safety management systems have been properly put into place and continue to operate in the way in which they are intended.

It is intended to be a 'living' document which describes the safety of an operation for the duration of the whole project—from initial concept design to termination of the operation and abandonment of any facilities and drives the continuous improvement of the risk management arrangements.

<http://www.industry.gov.au/index.cfm>

**Appendix No. 18:- APPEA Reporting Definitions**

**APPEA Reporting Definitions**

**Reportable Incident**

Under the APPEA Safety Incident Database Guidelines, an incident is reportable when the operating company has the “prevailing safety influence” over the activity that caused the incident. "Prevailing safety influence" occurs when the operator has control over the activity under consideration and is therefore in a position to positively influence (from a safety perspective) the way in which the activity is undertaken.

**Number of Hours Worked**

In accordance with the definition of "Reportable Incident", the total number of hours worked by employees and contractors is reported where the operator has the "prevailing safety influence".

**Lost Time Injury - LTI**

Is defined as an injury or occupational illness that results in a permanent disability; or time lost of one complete shift, day or longer, as defined on the current medical certificate.

**Alternate Duties Injury - ADI**

Is defined as an injury or occupational illness that results in the injured person:

being assigned to another job; or

working at their permanently assigned job with some restrictions on duties; or

working at their permanently assigned job with some restrictions on their working time for periods of a complete shift or day or more as defined on the current medical certificate.

**Medical Treatment Injury - MTI**

Is defined as any work-related loss of consciousness, injury or disease requiring more than minor First Aid treatment by a medical practitioner or registered medical personnel but not resulting in lost time or alternate / restricted duties.

### **Total Reportable Injuries - TRI**

Includes the following injury classifications: lost time injuries; medical treatment injuries;

alternative duties injuries; and fatalities.

### **Frequency Rate - FR**

Is defined as the number of injuries per one million hours worked. The frequency rate is calculated as follows:

*$(\text{Number of injuries in the period} \times 1,000,000) \div \text{Number of hours worked in the period}$*

### **Average Lost Time**

The average of the time lost for each lost time injury. This is a measure of severity of the injuries and is calculated as follows:

*$\text{Number of working days lost} \div \text{Number of LTIs in the period}$*

Appendix No. 19:- 2D Valve plan layout

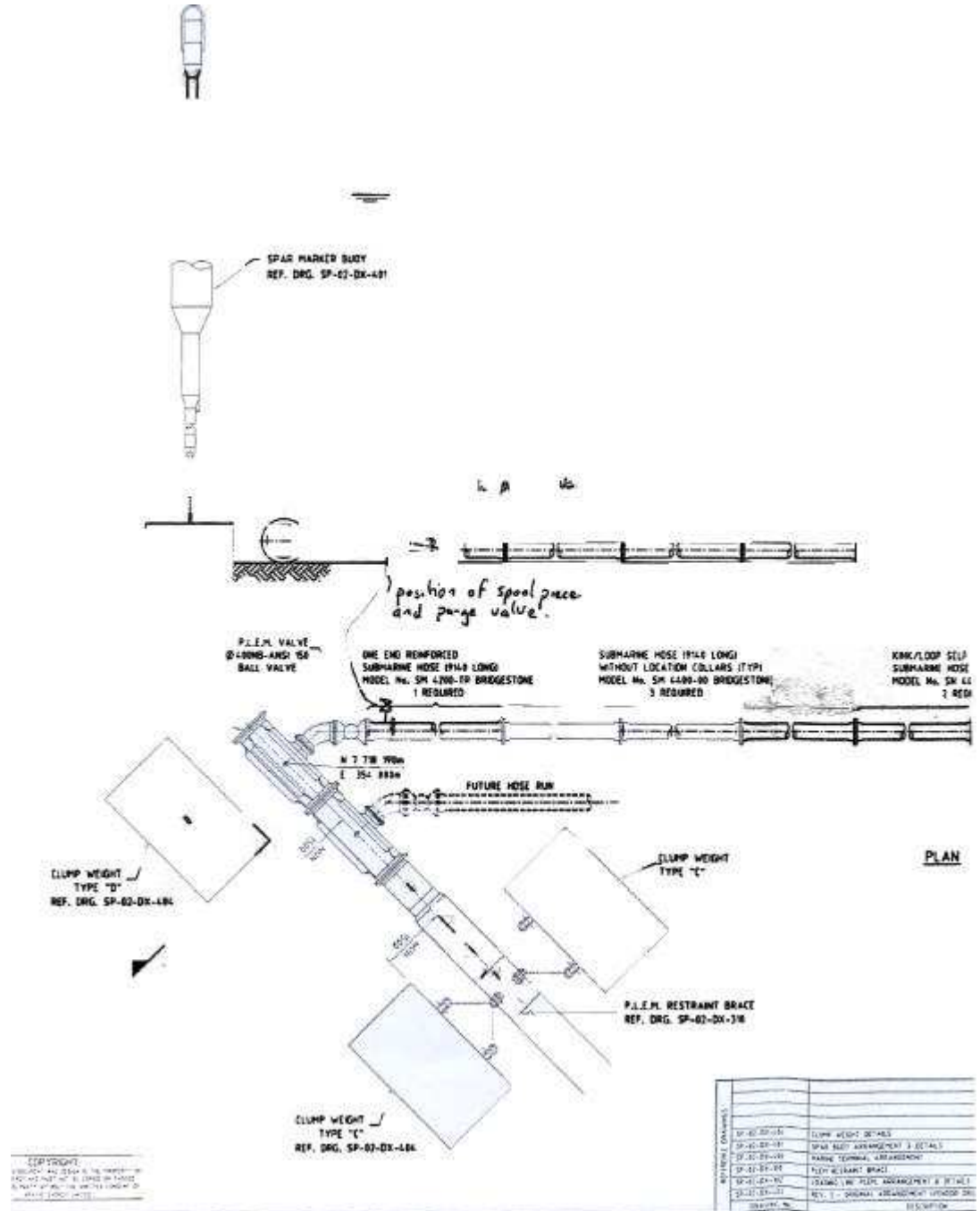

Appendix No. 20:- AIMS Solutions Landfill Inspection brochure

## Environmental

### Landfill inspection Training

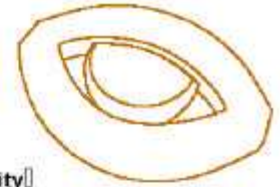

**The Environment Agency is using a virtual reality system to train landfill site inspectors.**



The Environment Agency has introduced, a virtual reality based training system developed by AIMS Solutions. The system is used nationwide and forms part of the Agency's course for waste site inspectors and aims to enhance the training experience and provide greater site inspection consistency.

The computer-based simulation enables users to navigate around a landfill site and randomly encounter a typical range of scenarios, hazards and events.



"Whilst the simulation does not seek to replace real life experience, it does offer some real benefits. Users can get quick and easy access to training without waiting for training courses, training budgets or experienced trainers to become available."

"The programme is cost and time effective, and early feedback from users indicates the retention of key information is enhanced because the approach to training is memorable and stimulating. Many staff are amazed by how much they remember when they come for their second training session."

Environment Agency Project Manager Howard Thorp

The key benefit emerging from the training is the development of a more consistent application of the Operator Performance Risk Assessment (OPRA) and the Agency's Site Inspection Methodology.



The site consists of a large landfill site and waste transfer station but has been designed to evolve, with liquid treatment facilities and new waste cells being potential additions. The system will shortly be available to the wider industry as Environment Agency ONSITE, a commercially available version of the software is in development.



aims

solutions

[aims-solutions.co.uk](http://aims-solutions.co.uk)



ENVIRONMENT  
AGENCY

Appendix No. 21:- Questionnaire

***Please tick the box that best suites you in relation to the question area***

**What area best covers you?**

Government-	Private-	Domestic-	Unemployed-	Student -	Other -
-------------	----------	-----------	-------------	-----------	---------

**What is your current working environment?**

Legal -	Medical -	Information Technology -	Engineering -	School/TAFE /Uni -	Office -	Other -
---------	-----------	-----------------------------	---------------	-----------------------	----------	---------

**What is your highest educational qualification achieved?**

PhD/Masters -	Bachelor -	Diploma -	Certificate -	High School -	Other -
---------------	------------	-----------	---------------	---------------	---------

**What access to a personal computer do you have?**

Have own -	Have continual access -	Have occasional access -	Have no access-	Do not want access -	Other -
------------	----------------------------	-----------------------------	--------------------	-------------------------	---------

**What is your current age?**

Less than 18-	18 to 25 -	26 to 40 -	41 to 55 -	56 to 65 -	66 or Older -
---------------	------------	------------	------------	------------	---------------

***On a scale of 0 to 5 with 0 being the least and 5 being the best please select (only one) for your answer.***

**Did the graphics depict what was being described?**

0 -	1 -	2 -	3 -	4 -	5 -
-----	-----	-----	-----	-----	-----

**Did the graphics demonstrate additional information that was not spoken of?**

0 -	1 -	2 -	3 -	4 -	5 -
-----	-----	-----	-----	-----	-----

**Did the graphics give you a preconceived idea of what was going on?**

0 -	1 -	2 -	3 -	4 -	5 -
-----	-----	-----	-----	-----	-----

**Did the graphics provide information for a better understanding?**

0 -	1 -	2 -	3 -	4 -	5 -
-----	-----	-----	-----	-----	-----

**Would graphics help you understand technical discussion?**

0 -	1 -	2 -	3 -	4 -	5 -
-----	-----	-----	-----	-----	-----

**Did the graphics depict reality?**

0 -	1 -	2 -	3 -	4 -	5 -
-----	-----	-----	-----	-----	-----

**Did the graphics provide a sense of reality?**

0 -	1 -	2 -	3 -	4 -	5 -
-----	-----	-----	-----	-----	-----

**Are graphics a useful tool for explaining things?**

0 -	1 -	2 -	3 -	4 -	5 -
-----	-----	-----	-----	-----	-----

**Are graphics a useful tool for demonstrating things?**

0 -	1 -	2 -	3 -	4 -	5 -
-----	-----	-----	-----	-----	-----

**Did you understand what the graphics were showing?**

0 -	1 -	2 -	3 -	4 -	5 -
-----	-----	-----	-----	-----	-----

**Did the graphics provide information that you did not know before?**

0 -	1 -	2 -	3 -	4 -	5 -
-----	-----	-----	-----	-----	-----

***Thankyou for filling this questionnaire out***

Appendix No. 22:- Innovation festival brochure



The brochure features a dark background with a red vertical bar on the left side. At the top center is a red circular logo with horizontal lines. Below it, the text 'AUSTRALIAN INNOVATION FESTIVAL' is displayed in white, with the website 'www.innovationfestival.com.au' underneath. A line of text reads 'Proudly supported by the Federal Department of Industry, Tourism & Resources'. To the right, a white box contains 'APRIL 29th - MAY 14th' and 'programme of events' in red. The left red bar contains six logos: 'INDUSTRY TOURISM RESOURCES', 'GOVERNMENT OF WESTERN AUSTRALIA Department of Industry and Technology', 'TECHNOLOGY PROMOTES HEALTHY PROFITS', 'Swish Group', 'Adair COMMUNICATIONS', and 'interactive'. The website 'www.innovationfestival.com.au' is repeated in large white font in the lower right, with a smaller version below it. At the bottom, a paragraph describes the festival as a series of showcase events across all States and Territories, held in Western Australia from 29 April to 14 May 2002, celebrating new ideas with potential commercial application, co-ordinated in Western Australia by the Department of Industry and Technology and funded by the Federal Government and private sector sponsors.

**AUSTRALIAN INNOVATION FESTIVAL**  
www.innovationfestival.com.au

Proudly supported by the Federal Department of Industry, Tourism & Resources

**APRIL 29th - MAY 14th**  
programme of events

**INDUSTRY TOURISM RESOURCES**

**GOVERNMENT OF WESTERN AUSTRALIA**  
Department of Industry and Technology

**TECHNOLOGY PROMOTES HEALTHY PROFITS**

**Swish Group**

**Adair**  
COMMUNICATIONS

**interactive**

**www.innovationfestival.com.au**  
www.innovationfestival.com.au

The Australian Innovation Festival is a series of showcase events across all States and Territories. Held in Western Australia from 29 April - 14 May 2002, the festival celebrates the value of new ideas - particularly those which have a potential commercial application. It is co-ordinated in Western Australia by the Department of Industry and Technology and funded by the Federal Government and private sector sponsors.



