

9-25-1988

A Study of Low Energy Ar⁺ Ion Bombardment Induced Lattice Damage in (100) n-GaAs by Channeling

S. K. Jindal
University of Texas at Austin

S. S. Lin
University of Texas at Austin

L. D. Brown
University of Texas at Austin

H. L. Marcus
University of Texas at Austin

M. A. Schmerling
University of Texas at Austin

Follow this and additional works at: <https://digitalcommons.usu.edu/microscopy>



Part of the [Life Sciences Commons](#)

Recommended Citation

Jindal, S. K.; Lin, S. S.; Brown, L. D.; Marcus, H. L.; and Schmerling, M. A. (1988) "A Study of Low Energy Ar⁺ Ion Bombardment Induced Lattice Damage in (100) n-GaAs by Channeling," *Scanning Microscopy*. Vol. 2 : No. 4 , Article 6.

Available at: <https://digitalcommons.usu.edu/microscopy/vol2/iss4/6>

This Article is brought to you for free and open access by the Western Dairy Center at DigitalCommons@USU. It has been accepted for inclusion in Scanning Microscopy by an authorized administrator of DigitalCommons@USU. For more information, please contact digitalcommons@usu.edu.



A STUDY OF LOW ENERGY Ar⁺ ION BOMBARDMENT INDUCED LATTICE
DAMAGE IN (100) n-GaAs BY CHANNELING

S.K. Jindal, S.S. Lin*, L.D. Brown, H.L. Marcus and M.A. Schmerling.

Center for Materials Science and Engineering, University of Texas at Austin
Austin, Texas 78712.

(Received for publication August 04, 1988, and in revised form September 25, 1988)

Abstract

It has been found that sputter cleaning of GaAs single crystals results in damage or loss of crystallinity in the first few tens of nanometers of the crystal. The damage is a result of both - energetic Ar ions impinging on and being incorporated in the GaAs surface and the resultant preferential sputtering of As from the GaAs lattice. A study of this damage which was done at room temperature and at -110 °C was made by the use of Selected Area Electron Channeling Patterns. The relationship between the degree of surface disorder, as shown by the pattern degradation, and sputtering parameters (ion beam voltage and ion beam dose) was experimentally obtained. The energy regime investigated was 0.5 to 5 keV with sputtering times from 5 to 20 minutes. The results showed increasing contrast degradation in the selected area channeling patterns (SACPs) with increasing incident ion energies from 0.5 to 4 keV, a maxima in contrast degradation for a sputtering time of 10 minutes and greater contrast degradation at room temperature than at -110 °C.

KEY WORDS: Channeling patterns, Lattice damage, (100)GaAs, Low energy Ar⁺ ion bombardment, Surface disorder, Ion-surface interactions, Low energy Ar⁺ sputtering of GaAs and Electron Channeling.

*Address for correspondence:
Steve S. Lin, ETC II 8.160, Department of Mechanical Engineering, University of Texas at Austin, Austin, TX 78712

Phone Nos (512) 471-3146 and (512) 471-3469

Introduction

Ion bombardment has been widely used as sputtering for many analytical techniques such as Auger electron spectroscopy (AES), secondary ion mass spectroscopy (SIMS), and X-ray photoelectron spectroscopy (XPS) in conjunction with the atomistic investigation of surface or near surface layers at some point in the analysis, or used as a controlled source for ion scattering such as Rutherford backscatter spectroscopy (RBS) and ion scattering spectroscopy (ISS). Also it can be used as ion milling for cross-section transmission electron microscopy (X-section TEM) sample preparation, or used as dry etching technique for semiconductor surface cleaning prior to metal deposition in case of the fabrication of metal-semiconductor contacts such as Schottky barriers and ohmic contacts.

The damage induced by ion impingement, i.e., the production of lattice defect and preferential sputtering of multicomponent compound is very complex. It can give rise to structural features that are not representative of the bulk material and interfere with the "ideal" study of the unaltered material. Different analytical techniques have been previously applied to investigate the induced damages of GaAs surfaces caused by Ar⁺ bombardment. Auger depth profiling and SIMS were used by Singer et al. (1981a) for the study of Ar⁺ ion implantation in the GaAs, as well as by McGuire (1978) and Singer et al. (1981 a, b) for the selective sputtering of Ga and As. Low energy electron diffraction (LEED) was used by Welkie and Lagally (1979), Palau et al. (1982), Wang and Holloway (1984) to study the surface imperfection. Selected Area Channeling Patterns (SACPs) have been used to evaluate the damaged layer by Hungsperger and Wolf (1970,1971), and Ishiguro et al. (1987). Until recently, X-section TEM was used for structural determination by Ivey and Piercy (1987), and Ishiguro et al. (1987).

This work investigates the variation of irradiation damage caused by low energy (0.5 to 5 keV) Ar⁺ ion impingement on a (100) GaAs surface at two temperatures as shown by the loss of contrast in the electron channeling pattern.

Selected Area Channeling Patterns (SACPs)

SACPs are diffraction patterns obtained when a parallel beam of electrons is rocked about a spot on a crystalline specimen and the backscattered and secondary electron intensity monitored versus the rocking angle. As the angle between the beam and the specimen changes, the penetration depth of the incident electrons changes due to the existence of "channels" in the atomic lattice. This gives rise to a variation in the number of backscattered and corresponding secondary electrons and hence the contrast

of the channeling pattern (Joy et al. 1986 and Newbury et al. 1986).

SACPs can be generated in the scanning electron microscope and the scanning transmission electron microscope. They are used in crystallographic orientation determination, material deformation studies, lattice parameter measurements and in the study of crystal imperfections. They provide localized information from 5 to 1000 micron diameter areas. The "information depth" or the depth below the object surface contributing to the SACP is a function of the atomic number of the sample and the acceleration voltage of the electrons employed. It ranges from 1 to 100 nms for an accelerating voltage of 20 keV (Davidson, 1983, 1984).

The SACP is a result of Bragg diffraction of electrons within the crystal and any imperfections in the crystal lattice will lead to a degradation of the channelling pattern quality. There are four measures of pattern degradation: a) pattern contrast, b) pattern line width, c) the number of higher order lines visible and d) degree of pattern distortion. We chose pattern contrast because pattern degradation could be quantified objectively by an image processor which could detect subtle differences in contrast over many pictures.

Experimental

Sample Preparation

M/A-COM single crystal Si-doped(100) GaAs with an etch pit density of 4900/cm² and resistivity of 0.0022 ohm-cm was loaded into an ultrahigh vacuum system without prior cleaning and then ion pumped to a base pressure of 1x10⁻⁸ torr. The samples were mounted with Al foil (low sputtering yield) on a Cu stage to avoid sputter deposition of the Cu stage onto the sample. The stage had a type K, Chromel - Alumel thermocouple embedded in it and a cold finger assembly attached to it for chilling the GaAs sample in vacuo. Steady state temperatures of -110 °C could be achieved. The samples were then bombarded by Ar⁺ ions utilizing a Physical Electronics, Inc. model 04-191 sputter ion gun with a model 20-115 ion gun control unit. Fluxes from 7 (0.5 keV) to 11 (5 keV) μA/cm² were used and independently measured with a Faraday cup and electrometer. The gun - to - sample separation distance was 5 cms. The sputtering was done at a normal incidence with an Ar pressure of 5x10⁻⁵ torr which was bled into the system via a non evaporative getter pump. Sputtered and unsputtered areas were obtained by placing a fabricated mask, made out of tungsten, on top of the sample. Thus, the sample had a built-in standard against which damage could be compared as shown in Fig. 1.

Sample analysis

After preparation the samples were removed from the UHV system and then ultrasonically cleaned in acetone and methanol and analyzed in a JSM35C Scanning Electron Microscope. Selected Area Channeling Patterns (SACPs) were obtained with a probe diameter of 10 microns at a fixed beam current of 6 nA and other instrument variables held constant for each sample.

SACPs were obtained with the electron probe centered on the unsputtered and sputtered regions by translating the specimen through fixed distances, verified visually by the clarity, or lack thereof, of the electron channeling pattern. Line scans on the SEM were difficult to obtain with sufficient contrast for analysis. Image processing in the Advanced Graphics Laboratory at the University of Texas was employed to obtain line scans.

The images were processed using a Grinell 270 frame buffer system. First, the images were digitized and then scanned along the (220) band to give an intensity versus

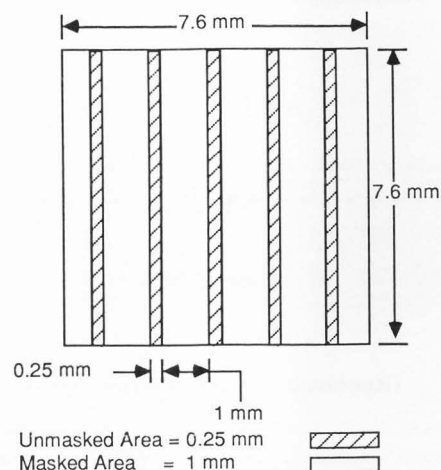

Figure 1. Schematic of an Ar⁺ ion sputter damaged (100) GaAs sample.

position map along this band edge. Pattern degradation for each sample was quantified by taking the damage ratio $\Delta I_D : \Delta I_{UD}$, "D", of the change in intensity for the sputtered area (ΔI_D) to the corresponding change (ΔI_{UD}) for an unsputtered area as shown in Fig. 2.

Repeatability of results was demonstrated by taking SACPs of the same sample on different days and confirming that the ratio $\Delta I_D : \Delta I_{UD}$ remained unchanged, although the individual peak to valley heights varied between runs from day to day due to variations in SACP parameters on the SEM.

Results

It should be noted that the damage was analyzed after as many as 55 days. The time lag between sample preparation and sample analysis seemed to have a significant effect on the contrast of the channeling pattern and this will be discussed later.

Fig. 3 shows the variation in the contrast of SACPs for the samples sputtered with incident Ar⁺ ion beam energies ranging from 0.5 keV to 5 keV with fluxes of 7 to 11 μA/cm² for 10 minutes at either room temperature or -110 °C. Except for the sample damaged at 5 keV at room temperature, increasing incident ion energy results in increasing degradation of the SACP contrast. The degradation of SACP contrast for room temperature damage at 2 keV and 4 keV is shown to be greater than the corresponding contrast for the damage done at -110 °C.

Figs. 4 and 5 show the loss of contrast versus sputtering time (flux of ~ 10¹³ Ar⁺/cm².sec) for samples sputtered with 2 keV and 4 keV incident Ar⁺ ion energies at room temperature and at -110 °C, respectively. Both plots show an interesting trend towards contrast degradation saturation after 10 minutes of sputtering and increase in channeling pattern contrast at 20 minutes.

Discussion

Damage of semiconductor surface due to Ar⁺ ion bombardment is primarily caused by displacement, ionization and implantation events such that the production of imperfections in the lattice is a cumulative effect of the events, such as point defect generation, Ar atom implan-

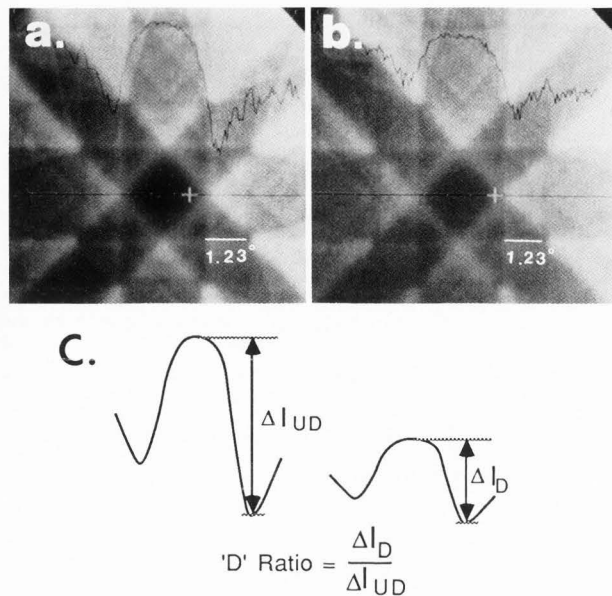

Figure 2. Line scans for a selected area channeling pattern obtained on the JSM 35 C for a (100) GaAs specimen held at -110°C and bombarded with 2 keV Ar^+ ions for 10 minutes. The damage ratio is obtained by averaging the ratios of the peak to valley heights obtained from both sides of the major peak.

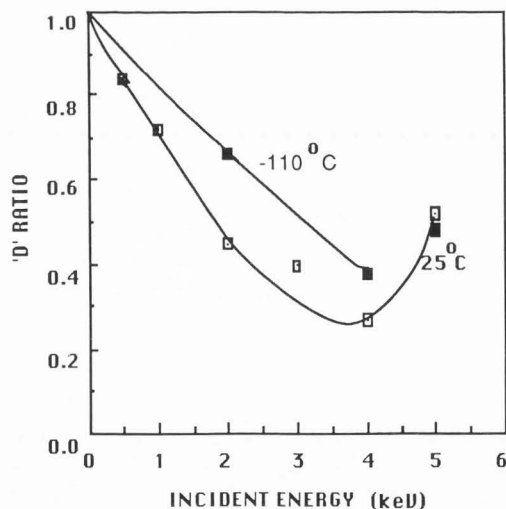

Figure 3. Plot of damage ratio versus incident Ar^+ ion energy, for a GaAs sample held at room temperature and at -110°C and sputtered for 10 minutes with Ar^+ ions having energies from 0.5 to 5 keV.

tation and displacement of Ga and As atoms, etc. Ivey and Piercy (1987) investigated the low energy ion milled GaAs by X-section TEM and characterized the microstructural features into three categories: a) precipitation of second-phase particles at the sample edge, b) a surface amorphous layer and c) subsurface damage layer. Other authors also showed that the first nanometer of GaAs sputtered by low energy Ar^+ ions should be amorphous under medium irradiation dose of 10^{17} ions/cm² (Naguib and Kelly, 1975;

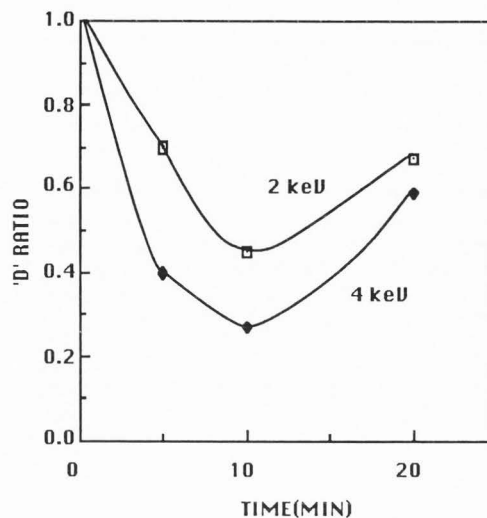

Figure 4. Plot of damage ratio versus sputtering time, for a GaAs sample held at room temperature and sputtered for 5, 10 and 20 minutes with 2 keV and 4 keV Ar^+ ions.

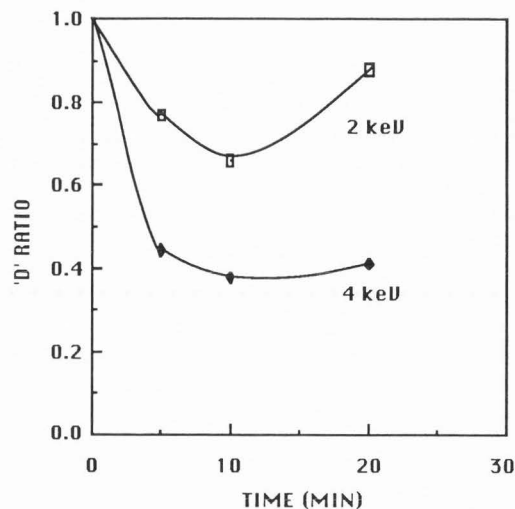

Figure 5. Plot of damage ratio versus sputtering time, for a GaAs sample held at -110°C and sputtered for 5, 10 and 20 minutes with 2 keV and 4 keV Ar^+ ions.

Welkie and Lagally, 1979). As well, Ishiguro et al. (1987) characterized several different substrates deposited with amorphous materials of different thickness as well as the ion milled semiconductors by X-section TEM and electron channeling patterns (ECPs), and correlated the degradation of ECP contrast of substrates with the thickness of deposited amorphous overlayers and the thickness of the damaged layers, respectively. It seems the loss of crystallinity of substrate due to ion bombardment, as well as deposition of amorphous materials, can result in the degradation in the channeling pattern contrast.

Without the annealing effect, the crystalline to amorphous transition occurs at a critical energy of 12 eV/atom for silicon, and probably occurs at the same order of energy for GaAs (Narayan and Holland, 1984). The minimum critical temperature of 130°C for recovering the

crystallinity was reported by Farren and Scaife (1968). In the experiment done by Bhattacharya et al. (1987), the temperature of the GaAs substrate, which was irradiated by 30 keV Ar⁺ ions of a relatively high dose of 10¹⁹ ions/cm², reached as high as 83 °C. Since the temperature of the substrate was kept lower than 30 °C, the recovery of crystallinity of GaAs seemed not to occur in this study.

Some abnormalities regarding the SACP contrast are:

a) Increasing degradation of SACP contrast of (100) GaAs single crystal were found with increasing incident Ar⁺ ion energies from 0.5 keV to 4 keV but decreasing degradation with 5 keV; b) The degradation of SACP contrast seemed to show a maximum in time both at room temperature and at -110 °C; c) More contrast degradation was found for GaAs damaged at room temperature than at -110 °C. As previously discussed, the degradation in SACP contrast can be caused by both the deposited amorphous overlayer and the damaged surfaces. The effect of native oxide on the channeling pattern of GaAs surface was not determined. This could have an effect and the long time exposure changes may be related to this.

It has been shown that, for clean samples exposed to air, the native oxide on GaAs is amorphous, composed of Ga₂O₃ and As₂O₃ (Stickle and Bomben, 1987) and reaches the saturation thickness of 3 nm in about 4 days (Pruniaux and Adams, 1972). Besides, the UHV system's sputtering conditions were simulated in the scanning Auger microprobe system (SAM, PHI model 590) within which the (100) virgin GaAs was sputter cleaned. The oxygen 509 eV and carbon 270 eV peaks were monitored as a function of time. It took about 15, 13, 11 and 9 minutes (equivalent to the time required in the UHV system) to sputter clean the GaAs by 2 keV, 3 keV, 4 keV and 5 keV Ar⁺ ions, respectively. It seemed that all the samples were covered with oxides resulting from either incomplete sputtering or reoxidation of clean surfaces. Certainly, the reoxidation of the clean GaAs surface due to the time lag between preparation and analysis reduces the surface damaged layer thickness, and thus gives rise to the increase in the SACP contrast.

In this work, the unspattered area of GaAs is used as a built-in reference, and the change in intensity, ΔI_{UD} , is used to quantify the degradation of SACP contrast. The reduction of damaged layer thickness due to the reoxidation does also introduce uncertainty even though we assume the native oxide is the same on the unspattered and spattered areas of the analyzed samples. In particular, it should be noted that the oxide thickness is of the same order of the damaged layer thickness. Due to the combined effects of the native oxide and surface damaged layer on the contrast degradation when compared with the reference, it is not possible to conclude that the differences in channeling pattern contrast is solely caused by the damaged layers. Regarding the observed abnormalities, a possible explanation is that, after a certain amount of sputtering to remove all the oxides, the clean and damaged layer reoxidized when samples were exposed to air and the thickness decreased resulting in an increase in SACP contrast. As well, slower sputtering rate on cooler samples might explain the temperature anomaly described in c).

In spite of the problems as discussed, selected area channeling pattern proves itself to be a valuable and convenient method to characterize amorphous overlayers on crystalline materials on a semiquantitative basis. In order to better understand the time dependent characteristics of GaAs single crystal bombarded by low energy Ar⁺ ions, use of a clean surface free of oxides and damages as a reference, as well as in situ investigation to eliminate the interference of subsequent oxidation is required.

Conclusion

Surface damage layer caused by low energy ion bombardment and amorphous oxide overlayer can be semi-quantitatively characterized by the degradation contrast in selected area channeling pattern. The time dependent degradation characteristics of sputtered GaAs single crystal can be evaluated if special care is taken to avoid the interfering effects of native oxide.

Acknowledgement

This study was supported by the Texas Advanced Technology and Research Program.

Reference

- Bhattacharya SR, Ghose D, Basu D, Karmohaparto SB. (1987). Surface topography of Ar⁺ bombarded GaAs(100) at various temperature. *J. Vac. Sci. Technol. A5*, pp. 179-183.
- Davidson DL. (1983). The quantification of deformation using electron channeling. *Scanning Electron Microsc. 1983; III: 1043-1050.*
- Davidson DL. (1984). Uses of electron channeling in studying material deformation. *International Metals Reviews. Vol. 29*, pp. 75-95.
- Farren J, Scaife WJ. (1968). Sputtering of GaAs single crystals by 8-16 keV argon ions. *Talanta. Vol.15*, pp. 1217-1226.
- Hunsperger RG, Wolf ED. (1970). Measurement of Ion Implantation Lattice damage in (111) GaAs using the scanning electron microscope. *Applied Physics Letters, 16*, pp. 526-529.
- Hunsperger RG, Wolf ED, Shifrin GA, Marsh OJ, Jamba DM. (1971). Measurement of lattice damage caused by Ion-Implantation doping of semiconductors. *Radiation Effects. Vol. 9*, pp. 133-138.
- Ishiguro T, Suzuki T, Suzuki N, Ozawa M. (1987). Structure modification of surface layer induced by ion milling. *J. Electron Microsc. Vol. 36*, pp. 163-167.
- Ivey DG, Piercy GR. (1987). Radiation damage effects in GaAs transmission electron microscopy specimens prepared by ion milling. *Thin Solid Films, 149*, pp. 73-83.
- Joy DC, Romig AD, Goldstein JJ. (1986). Radiation damage from ion thinning processes. In: *Principles of Analytical Electron Microscopy*. Plenum, pp. 387-390.
- McGuire GE. (1978). Effects of ion sputtering on semiconductor surfaces. *Surface Science, 76*, pp. 130-147.
- Naguib HM, Kelly R. (1975). Criteria for bombardment-induced structural changes in non-metallic solids. *Radiation Effects. Vol. 25*, pp. 1-12.
- Narayan J, Holland OW. (1984). Characteristics of ion-implantation damage and annealing phenomena in semiconductors. *J. Electrochem. Soc. Vol. 131*, pp. 2651-2662.

Newbury DE, Joy DC, Echlin P, Fiori CE, Goldstein JJ. (1986). Electron Channeling Contrast in the SEM. In: Advanced Scanning Electron Microscopy and X-Ray Microanalysis. Plenum, pp. 87-145.

Palau JM, Testmale E, Ismail A, Lassabatere L. (1982). Silver Schottky diodes on Kelvin, AES and LEED characterized (100) surfaces of GaAs cleaned by ion bombardment. Solid-State Electronics. Vol. 25, pp. 285-294.

Pruniaux BR, Adams AC. (1972). Dependence of barrier height of metal semiconductor contact (Au-GaAs) on thickness of semiconductor surface layer. J. Appl. Phys. 43, pp. 1980-1982.

Singer IL, Murday JS, Comas J. (1981a). Preferential sputtering from disordered GaAs. J. Vac. Sci. Technol. 18, pp. 161-163.

Singer IL, Murday JS. (1981b). Surface composition changes in GaAs due to low-energy ion bombardment. Surface Science. 108, pp. 7-24.

Stickle WF, Bomben KD. (1987). Angle-dependent X-ray photoelectron spectroscopy investigation of GaAs surfaces. Thin Solid Films, 154, pp. 301-307.

Wang YX, Holloway PH. (1984). Effect of ion sputtering on interface chemistry and electrical properties of Au GaAs(100) Schottky contacts. J. Vac. Sci. Technol. B2, pp. 613-619.

Welkie DG, Lagally MG. (1979). Correlation of short-range order and sputter dose in GaAs(110) using a vidicon-based LEED system. J. Vac. Sci. Technol. 16, pp. 784-788.

Discussion with Reviewers

D.L. Davidson: Why were SACPs made at 20 keV, rather than a lower voltage which might be susceptible to surface damage?

Authors: The generation of contrast in SACP is a choice of operation conditions like the acceleration voltage of the primary electrons, the probe diameter, beam current, collimation and scan angle, etc. The resolution of the micrographs taken at lower acceleration voltage of primary electrons, i.e., 5 and 10 keV, was very poor because the maximum beam current for necessary contrast was limited by the instrument to 6 nA. Thus, acceleration voltage of 20 keV of primary electrons was applied.

D. Dingley: The background levels in Fig. 2a and b changed markedly across the micrograph. This must give rise to problems in measuring $\Delta I_D/\Delta I_{UD}$.

Authors: The change of the background level in the micrographs was caused by the misalignment of the electron column and the thermal drift of the filament. Thus, the damage ratio $\Delta I_D:\Delta I_{UD}$, "D", was taken on both sides of the central peaks shown in Fig. 2c for comparison. It was interesting that the difference was less than 5 percent such that the averaged result was still significant.