

ADVANCED COMPUTATIONAL ELECTROMAGNETICS AT BAE SYSTEMS

ADVANCED COMPUTATIONAL ELECTROMAGNETICS AT BAE SYSTEMS

Professor Chris Jones

Technologist Consultant – Lightning, EMP & CEM, BAE Systems

Phil Sewell, Trevor Benson, Ana Vukovic, Xuesong Meng

Nottingham University

Henry Bucklow

Principal Software Engineer, ITI

INTRODUCTION

Modern aircraft contain an ever-increasing array of complex, critical, electronic systems. The ability to predict and model electromagnetic environments for new concepts, and undertake qualification and clearance of aircraft into service, is critical. Products must be protected against electromagnetic interference, induced effects of lightning strikes, and high intensity radiated fields, and computational electromagnetic simulation is an essential tool for understanding and predicting electromagnetic performance.

Conventional approaches for computational electromagnetic modelling (CEM), based around a transmission-line method applied to a uniform Cartesian grid, cannot provide sufficient resolution to meet BAE Systems future requirements, without requiring a prohibitive amount of computing resource to run the resulting simulations. Consequently, BAE Systems and University of Nottingham are developing Unstructured Transmission-Line Modelling (UTLM) as a new technique for CEM, applying transmission-line modelling to unstructured meshes, allowing better representation of geometry and improved adaptability.

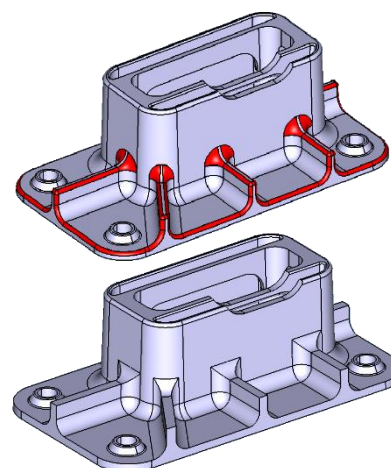

Figure 1: Automatic detection and removal of fillets.

ADVANCED COMPUTATIONAL ELECTROMAGNETICS AT BAE SYSTEMS

1: Geometry preparation

Key to the success of BAE Systems' UTLM workflow is the effective preparation of geometry for meshing. The tetrahedral meshes required for UTLM simulations impose similar requirements on the input geometry to typical stress, thermal, or CFD problems; however the physics of electromagnetic simulation also requires specialised model preparation to adapt and simplify CAD models.

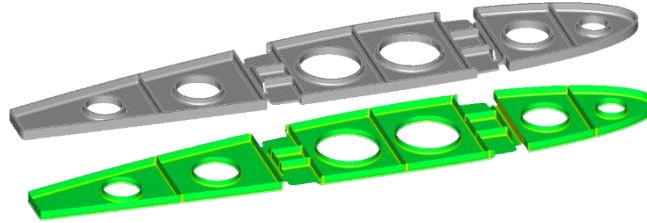

Figure 2: Automatic mid-surfaces generated using the 3D medial object. Colour contours indicate thickness of the original object.

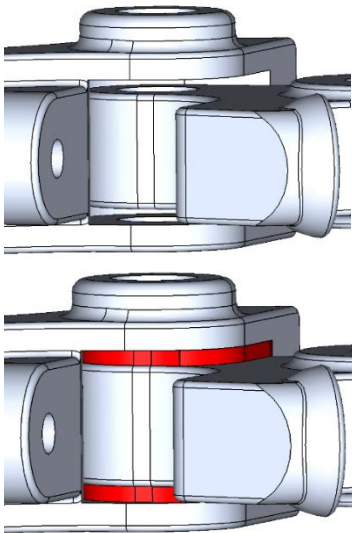

Figure 3: An automatically constructed weld between two adjacent components.

The simulation process starts with the manufacturing CAD model, which contains a lot of details which are unnecessary for CEM. In particular, fillets are generally not required, so fast, robust, and failure tolerant automatic fillet removal methods have been developed (figure 1). Small holes and protrusions are also removed automatically.

Thin-walled structures are common in airframe models, and are often most efficiently represented using midsurfaces; however, midsurface extraction remains a labour intensive process with existing tools. New techniques based on the 3D medial object show promise for automatic midsurface extraction on complex models (figure 2).

Electrical connectivity is critical to CEM. The manufacturing CAD model only defines the adjacency of different components; before meshing for UTLM, single shared faces must connect bodies which are electrically connected. Two tools can automate this process: imprinting, and welding. Imprinting discovers bodies in contact, and matches CAD topology across the contact, joining the bodies. Welding detects small gaps between bodies, and constructs shims to fill these gaps (figure 3).

ADVANCED COMPUTATIONAL ELECTROMAGNETICS AT BAE SYSTEMS

Requirements for geometric fidelity vary across the CEM model. Shrinkwrap techniques provide a 1-click method for preparing less critical regions. Conventional shrinkwrap methods generate faceted results, which are difficult to integrate with accurate CAD solids, so methods have been developed for converting shrinkwrap regions back into CAD geometry.

2: Variational assessment using the UTLM method

A critical activity at BAE Systems is managing uncertainty in complex environments. A key use of CEM is to assess particular sensitivities and here we briefly present one particular example this work.

The UTLM method has recently been enhanced to model the crosstalk between a single wire and a twisted wire pair when the wires are terminated with different loads. Fig.4 (a) shows the side and top views of the wire configuration. In the configuration, a single core wire with a radius of 0.4 mm is excited as the source by a network analyser. A twisted wire pair is used as a victim wire, which is made by folding a single core wire of length $2L$ and twisting the two halves as shown in the top view. The wires are placed near an L shape ground plane with the distances of $d = 12.5$ cm and $h = 8$ cm as in the side view, and mounted on the two metal bulkheads using SMA bulkhead connectors as in the top view. The separations between the ports are $s_1 = 2$ cm and $s_2 = 1$ cm. The length of wires is 100 cm. The twisted wire pair has 5 twists along the length. Port 1 is connected to P1 of the network analyser as excitation; while port 2 is connected to P2 of the network analyser as observation. Port 3 and port 4 are connected to

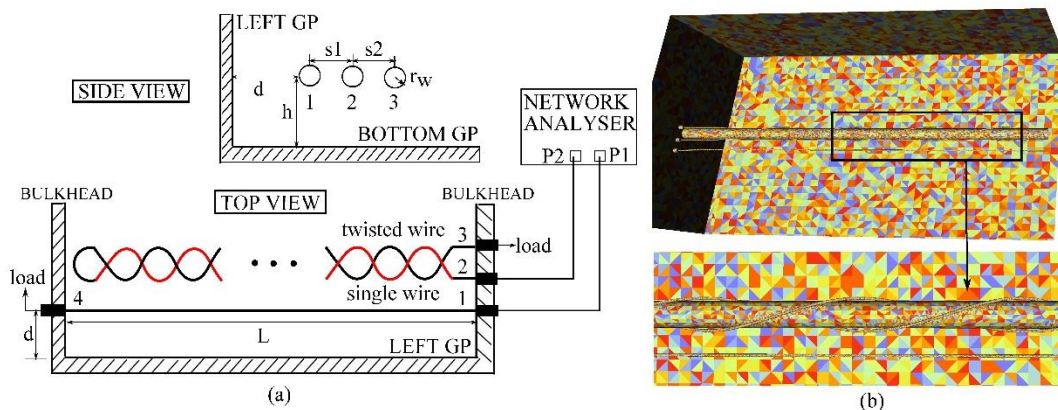

Figure 4: A single wire and a twisted wire pair are near an L shape ground plane. (a) The schematic side view and top view (b) The meshed geometry: the triangulated interfaces between different materials; randomized colouring is used to show the triangle sizes and shapes.

ADVANCED COMPUTATIONAL ELECTROMAGNETICS AT BAE SYSTEMS

a load, which could be a short circuit, 50 ohms or open circuit.

In order to keep a constant separation between the twisted wires along the length, a Nylon rod with a diameter of 1.5 cm is used as a support upon which to twist the wires. Fig. 4 (b) shows the meshed structure, which is meshed using University of Nottingham (UoN) in-house Delaunay Mesher software as a hybrid tetrahedral-cubic mesh.

Fig.5 shows the crosstalk between a single wire and a twisted wire pair when port 3 and 4 of wires are terminated with short circuit, 50 ohms load and open circuit in turn, measured experimentally and also calculated using UTLM simulation. The UTLM results agree very well with the experimental ones, proving the accuracy of the UTLM simulations. The results also show the termination of wires affects the crosstalk between a single wire and a twisted wire pair at relatively low frequencies and not much at relatively high frequencies.

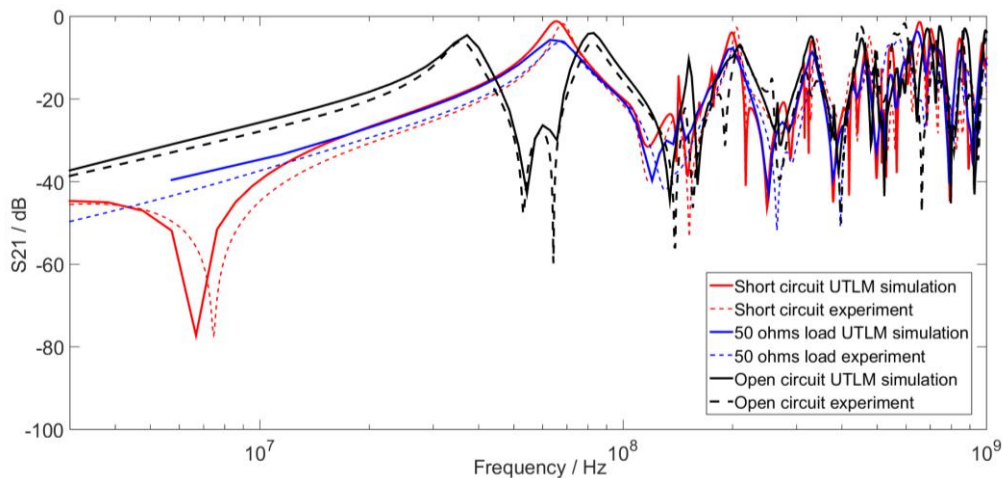

Figure 5: Comparison of the UTLM simulation and experiment results for the crosstalk between the single wire and the pair of twisted wires when ports 3 and 4 are terminated with short circuit, 50 ohms load and open circuit.

3: Conclusion

BAE Systems and University of Nottingham are developing UTLM, a new technique for CEM, to ensure that BAE Systems can meet their future electromagnetic simulation requirements. New automated model preparation tools have been added to ITI CADfix, to allow UTLM simulation from complex CAD geometry. An example use of UTLM has been demonstrated, successfully predicting the crosstalk between a single wire and a twisted wire pair.