



The University of  
**Nottingham**

UNITED KINGDOM · CHINA · MALAYSIA

Daya, Febin J.L. and Sanjeevikumar, Padmanaban and Blaabjerg, Frede and Wheeler, Patrick and Olorunfemi Ojo, Joseph and Ertas, Ahmet H. (2016) Analysis of wavelet controller for robustness in electronic differential of electric vehicles: an investigation and numerical developments. *Electric Power Components and Systems*, 44 (7). pp. 763-773. ISSN 1532-5008

**Access from the University of Nottingham repository:**

<http://eprints.nottingham.ac.uk/33377/1/Analysis%20of%20Wavelet%20Controller%20for%20Robustness%20in%20Electronic%20Differential%20of%20Electric%20Vehicles%20An%20Investigation%20and%20Numerical%20Developments%20version%202.pdf>

**Copyright and reuse:**

The Nottingham ePrints service makes this work by researchers of the University of Nottingham available open access under the following conditions.

This article is made available under the University of Nottingham End User licence and may be reused according to the conditions of the licence. For more details see:  
[http://eprints.nottingham.ac.uk/end\\_user\\_agreement.pdf](http://eprints.nottingham.ac.uk/end_user_agreement.pdf)

**A note on versions:**

The version presented here may differ from the published version or from the version of record. If you wish to cite this item you are advised to consult the publisher's version. Please see the repository url above for details on accessing the published version and note that access may require a subscription.

For more information, please contact [eprints@nottingham.ac.uk](mailto:eprints@nottingham.ac.uk)

# Short Title

## Wavelet Controller for Electric Vehicles

J.L. Febin Daya<sup>a</sup>, P.Sanjeevikumar<sup>b,\*</sup>, Frede Blaabjerg<sup>c</sup>, Patrick Wheeler<sup>d</sup>,  
Joseph Olorunfemi Ojo<sup>e,f</sup>, Ahmet H.Ertas<sup>h</sup>,

<sup>a</sup> School of Electrical & Electronics Engineering, Vellore Institute of Technology University,  
Chennai-600 127, India

<sup>b</sup> Ohm Technologies, Research & Development, Chennai, Tamil Nadu-600122, India.

<sup>c</sup> Department of Energy Technology, Aalborg University, Pontoppidanstraede 101,  
9220-Aalborg, Denmark.

<sup>d</sup> Power Electronics, Machines and Control Group, Department of Electrical & Electronics  
Engineering, Nottingham University, NG7 2RD-Nottingham, United Kingdom.

<sup>e</sup> Center for Energy System Research, Department of Electrical & Computer Engineering,

<sup>f</sup> Tennessee Technical University, Cookeville, 38505-Tennessee, United State of America.

<sup>g</sup> Eskom Centre of Excellence in HVDC Engineering, University of KwaZulu-Natal, Durban,  
South Africa.

<sup>h</sup> Biomedical Engineering Department, Engineering Faculty, Karabuk University,  
Demir-Celik Campus, Balıklarkayası Mevkii 78050, Karabuk, Turkey.

\* Corresponding author. Email: sanjeevi\_12@yahoo.co.in

# Analysis of Wavelet Controller for Robustness in Electronic Differential of Electric Vehicles – An Investigation and Numerical Developments

J.L. Febin Daya<sup>a</sup>, P.Sanjeevikumar<sup>b,\*</sup>, Frede Blaabjerg<sup>c</sup>, Patrick Wheeler<sup>d</sup>,  
Joseph Olorunfemi Ojo<sup>e,f</sup>, Ahmet H.Ertas<sup>h</sup>,

<sup>a</sup> School of Electrical & Electronics Engineering, Vellore Institute of Technology University, Chennai-600 127, India

<sup>b</sup> Ohm Technologies, Research & Development, Chennai, Tamil Nadu-600122, India.

<sup>c</sup> Department of Energy Technology, Aalborg University, Pontoppidanstraede 101, 9220-Aalborg, Denmark.

<sup>d</sup> Power Electronics, Machines and Control Group, Department of Electrical & Electronics Engineering, Nottingham University, NG7 2RD-Nottingham, United Kingdom.

<sup>e</sup> Center for Energy System Research, Department of Electrical & Computer Engineering,

<sup>f</sup> Tennessee Technical University, Cookeville, 38505-Tennessee, United State of America.

<sup>g</sup> Eskom Centre of Excellence in HVDC Engineering, University of KwaZulu-Natal, Durban, South Africa.

<sup>h</sup> Biomedical Engineering Department, Engineering Faculty, Karabuk University, Demir-Celik Campus, Balıklarkayası Mevkii 78050, Karabuk, Turkey.

\* Corresponding author email: sanjeevi\_12@yahoo.co.in

**Abstract:** In road transportation system, differential plays an important role of preventing the vehicle from slipping on curved tracks. In practice mechanical differentials are used, but they are bulky by increased weight. Moreover not suitable for electric vehicles especially those employing separate drives for both the rear wheels. Recently, the electronic differential constitutes technological advances in electric vehicle design enabling with better stability and control of the vehicle on curved roads. This paper articulate the modelling and simulation of an electronic differential employing a novel wavelet transform (WT) controller for two brushless DC (BLDC) motors ensuring the drive of two back driving right- and left-wheels. Further, the proposed work uses discrete wavelet transform (DWT) controller to decompose the error between actual and command speed provided by the electronic differential based on throttle and steering angle as the input into frequency components. By scaling these frequency components by their respective gains, obtained control signal which is actually given as input to the motor.

To verify the proposal, a set of designed strategies were carried in particular, vehicle on a straight, turning right and left on road. Numerical simulation test results for both PID and WT controllers are presented and compared for its robust performances and stability.

**Keywords:** Electronic differential, electric vehicle, wavelet controller, traction control, brushless dc motor, PID controller.

## **1. Introduction**

Increasing population, today's world demands for automobiles also drastically increased at the same time safety on the road becoming a major concern. A differential in transmission system in an automobile plays an important role of preventing the vehicle from slipping on curved roads. Conventional automobiles are making use of a mechanical gear train for their functioning. But, mechanical differentials are bulky by increased weight and not suitable for electric vehicles especially those employing separate drives for both the rear wheels. Electronic differential constitutes technologically advances in electric vehicle design ensures stability and better control on curved roads. Further, electronic differentials have a larger life span as they are programmed devices controlling the individual speeds of motors. Moreover, the increased popularity of electric vehicles is due to the reduced emissions (free of pollution), reduction in fuel consumption, weightless and non-bulky, performs all functions of the mechanical differential and hence has a potential future.

For improving air quality and traffic problems in check, for personal transportation, Neighbourhood Electric Vehicles (NEV) is the best present solution [1]. Implementation carried out for NEV with two independent wheels drives using induction motors using digital signal processor, where the current and speed controllers are standard PID controllers. It was verified that by concentrating all control variables in the same memory, the system robustness was highly improved [1]. FPGA (Field Programmable Gate Array) based an integrated control

system for NEVs AC motor drives was investigated and shown that exploiting the parallel processing capabilities of FPGA is used to execute several control schemes without compromise the overall system performance [2]. Renowned control methods like fuzzy logic are employed in the speed controller to fine-tune the slip rate of each wheel of the electric vehicle and verified smooth propagation on the straight line and the curved roads [3]. The advantage of fuzzy controllers does not requires prior information about mathematical model of the plant while still being robust. Until now, electronic differentials have been used to control the motors with a speed controller governed by a PID or Fuzzy controller [1-7]. Recently, the discrete wavelet transform (DWT) has been replaced the PID controllers and thankful to technology for its robustness [8-14]. WT found applications in ac drives, where pulse-width modulation (PWM) are carried out for single-phase (dc-ac) and three-phase (ac-dc) converters, performed better than standard PWM techniques by experimental verifications [8-9]. WT techniques are also extended to ac motor applications [10-14], in particular to control electrical vehicles (EV). For steering control of electrical vehicles fuzzy-neural control WT algorithms are implemented (ac motor drives) [15]. Also WT are applied successfully for energy management system in plug-in hybrid electric vehicles (HEV) [16]. Recently the WT effectively extended to fault diagnostics in multilevel power converters during short circuit conditions based adaptive neural-fuzzy interface systems [17-18].

To exploit the advantages of WT, this work articulate an electronic differential with a novel WT controller indirect field oriented control (IFOC) for two BLDC motors. The complete modeling of electronic differential employing two ac motors ensuring the drive of two rear wheels are carried out in the Matlab/Simulink software. Set of obtained results are provided with the comparison between PID and WT controller for its robust and stability under designed strategically conditions of electrical vehicle driving on curved roads.

This research investigation work is articulated as follows. In section 2, describes the dynamics of system modeling of electronic differential and BLDC motor. The discrete WT based on

speed controller, selection of WT, level of decomposition and WT electronic differential of electric vehicle is described in section 3. Complete set of numerical simulation test results along with performances indices obtained are given by section 4, based on three different designed strategically driving conditions on curved roads. Also, factor affecting WT controller functioning and stability verification by bode plots are given in the same section 4. Finally, the conclusions of this research paper are given by section 5.

## 2. System Modeling of Electronic Differential and BLDC Motor

Design of electronic differential should permit the vehicle to transverse a curved path or road without slipping. For this purpose two inputs are the necessary functions, first steering angle and second throttle position. To avoid slipping and collapse of the vehicle, above stated two functions decides the speed of the right and the left wheel during propagation [15-16].

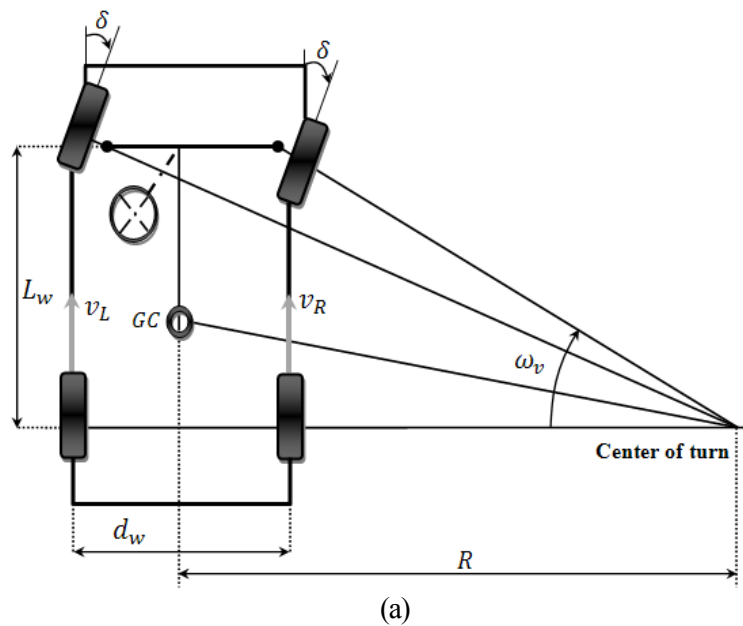

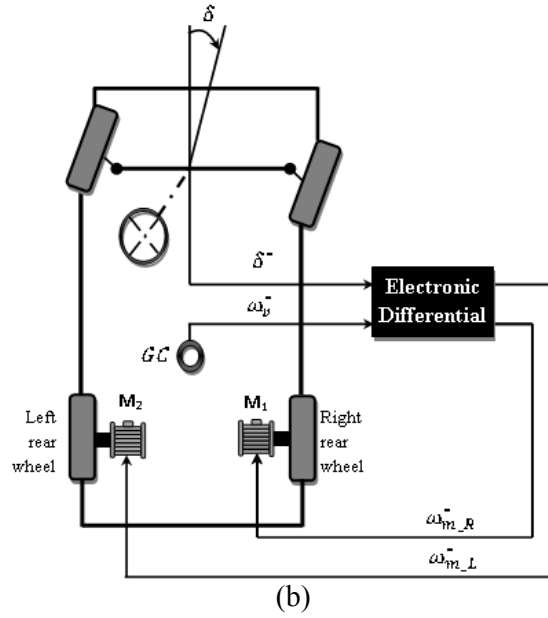

Fig. 1. (a) Schematic of electric vehicle with the electronic differential under investigation, (b) Schematic of the electric vehicle driven on curved road.

Fig. 1(a) illustrates the schematic of electronic differential proposed, where both the left and right wheels are controlled by two separate motors. In case of right turn, the differential will have to retain left wheel at higher speed than the right wheel, hence prevent the tyres from losing traction on turning (right) and vice-versa (left) [18]. Fig. 1(b) illustrates the electric vehicle turn on curved roads [18]:

Where,

$L_w$  is the wheel base,

$\delta$  is the turning angle,

$d_w$  is the track width,

$R$  is the radius of the turn and  $\omega_R$  and  $\omega_L$  represent the angular speeds of the left and the right wheel respectively.

By the function of vehicle speed and the radius of the turn, the linear speed of each wheel is expressed as below:

$$— (1)$$

$$v_R = \omega_v \left( R - \frac{d_w}{2} \right) \quad (2)$$

The expression relating the radius of the turn, steering angle and wheel base is given by:

$$R = \frac{L_w}{\tan \delta} \quad (3)$$

By substitution Eq. 3 in Eq. 1 and Eq. 2, the angular speed of each wheel is express as:

$$\omega_{r_L} = \frac{L_w + \frac{1}{2}d_w \tan \delta}{L_w} \omega_v \quad (4)$$

$$\omega_{r_R} = \frac{L_w - \frac{1}{2}d_w \tan \delta}{L_w} \omega_v \quad (5)$$

Now, the difference in angular speeds between wheel drives is written as below:

$$\Delta\omega = \omega_{r_L} - \omega_{r_R} = \frac{d_w \tan \delta}{L_w} \omega_v \quad (6)$$

The direction of the turn is decided by the sign of the steering, which is actually given by:

- For turn right i.e.  $\delta > 0$ ,
- For turn left i.e.  $\delta < 0$ ,
- For straight ahead i.e.  $\delta = 0$ .

The driver provides the steering input, the electronic differential executes the immediate action by reduces the speed of the inner wheel and increases the speed of the outer wheel. Now, the driving speeds of the wheels are expressed as below:

$$\omega_{r_L}^* = \omega_v + \frac{\Delta\omega}{2} \quad (7)$$

$$\omega_{r_R}^* = \omega_v - \frac{\Delta\omega}{2} \quad (8)$$

In standard drivers are BLDC motors widely used in electrical vehicle, and two types of BLDC motors used in practice i.e interior rotor or outer rotor type, both types is made of permanent magnets (rotor). In BLDC motor number of magnet pieces is equal to the motor pole numbers and phase windings are distributed on stators to form trapezoidal shape back-EMF. Also, benefits increased efficiency, higher torque density; noise-less operation and less maintenance



attract BLDC motors in electric vehicle propulsion. Mathematical model of three phase BLDC motors as given by Fig. 2 is described by the following equation:

$$\begin{bmatrix} V_a \\ V_b \\ V_c \end{bmatrix} = \begin{bmatrix} R & 0 & 0 \\ 0 & R & 0 \\ 0 & 0 & R \end{bmatrix} \times \begin{bmatrix} i_a \\ i_b \\ i_c \end{bmatrix} + \begin{bmatrix} L-M & 0 & 0 \\ 0 & L-M & 0 \\ 0 & 0 & L-M \end{bmatrix} \frac{d}{dt} \begin{bmatrix} i_a \\ i_b \\ i_c \end{bmatrix} + \begin{bmatrix} e_a \\ e_b \\ e_c \end{bmatrix}$$

Where,

$V_{a,b,c}$  are the three-phase voltage,

$i_{a,b,c}$  are the three-phase current,

$e_{a,b,c}$  are the phase back-EMF,

$R, L$  are the stator resistance and stator inductance,

$M$  is the mutual inductance respectively.

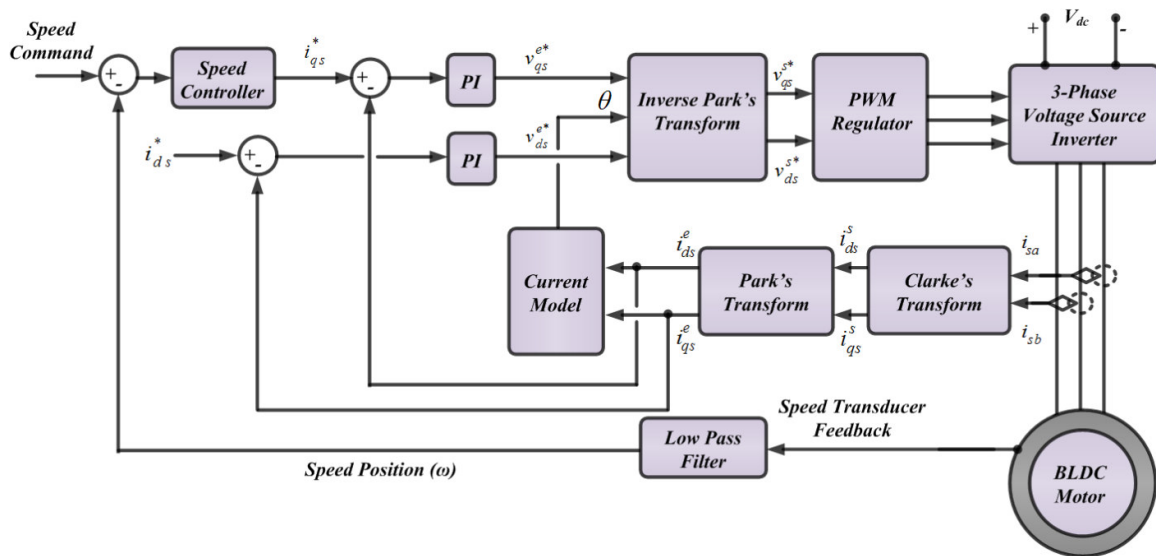

Fig. 2. Schematics of indirect field oriented control (IFOC) of BLDC motor drive.

### 3. Wavelet Transform based Speed Controller

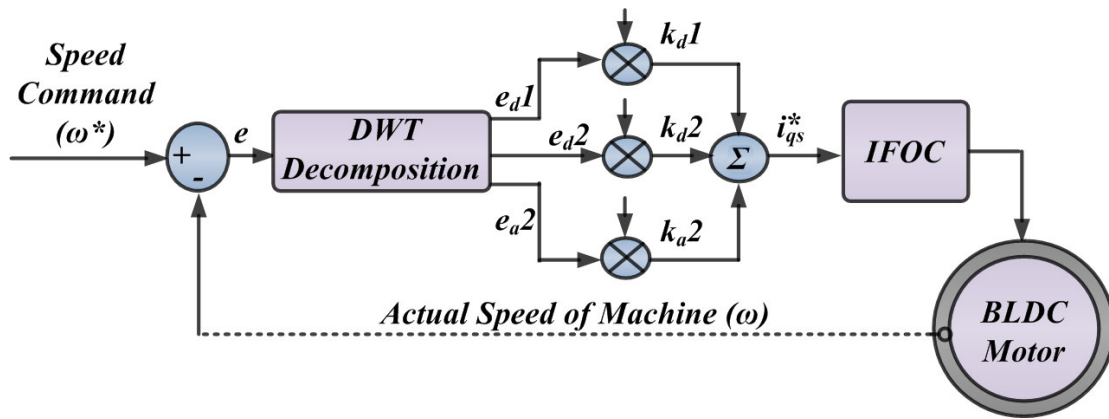

Fig. 3. Schematics of IFOC wavelet speed control scheme for BLDC motor.

Overall schematic details of the WT speed controller of a BLDC motor drive is given by Fig. 3 [11-14]. For sensitive speed regulation for both the right and left motors, WT is employed to each speed controller of the two BLDC motor drives. The type of WT and the number of decomposition levels are two criterions for WT controller.

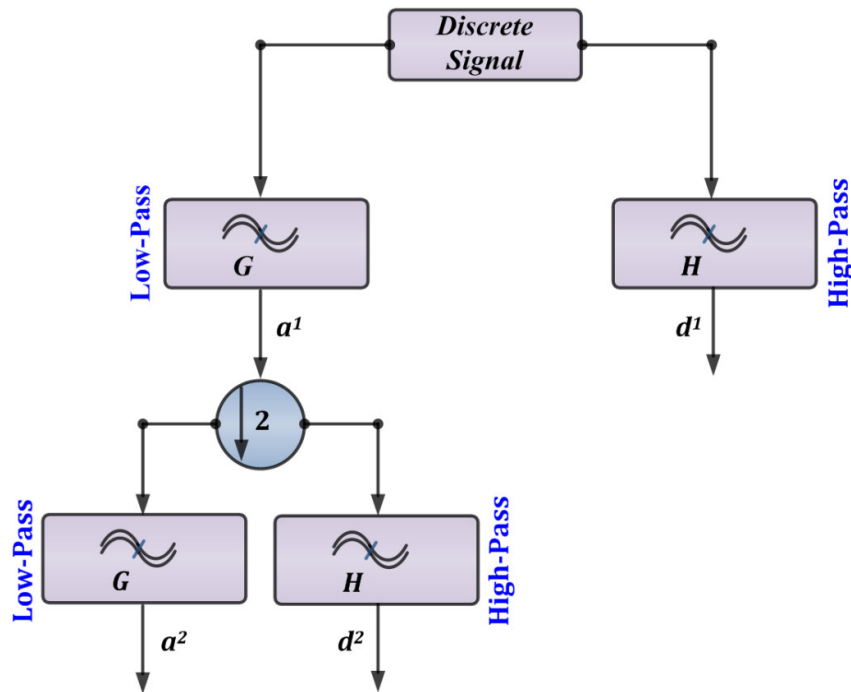

Fig. 4. Schematics of DWT 2-level decomposition algorithm.

The DWT is a time scale representation of digital signals using digital filtering techniques. Resolution of DWT is changed by filtering operations and the scales are changed by the down

sampling operations, typical 2-level decomposition tree is shown in Fig. 4. Decomposition begins when a discrete signal  $x[n]$  of length  $N$  is passed through a high pass filter, resulting in an impulse response  $h[n]$  and through a low pass filter results in impulse response  $g[n]$ . A 1-level decomposition of DWT is constituted by the outputs of high and low pass filter and mathematically expressed as below [10-14, 19-20]:

$$d^1[n] = \sum_{k=0}^{N-1} x[k]h[n-k] \quad (9)$$

$$a^1[n] = \sum_{k=0}^{N-1} x[k]g[n-k]. \quad (10)$$

where,  $d^1[n]$  and  $a^1[n]$  are the outputs of the high and low pass filters respectively. Again the output from the low pass filter is down sampled by two and passed through a low and a high pass filter resembling the ones in the 1-level. Now, the 2-level of decomposition of the discrete signal is down sampled mathematically as below:

$$d^2[n] = \sum_{k=0}^{N/2-1} a^1[k]h[n-k] \quad (11)$$

$$a^2[n] = \sum_{k=0}^{N/2-1} a^1[k]g[n-k] \quad (12)$$

### ***3.1. Selection of Wavelet function***

Several types of WT are available, but the selection depends on signal fits the applications. For this proposed investigation, the WT analysis is to be applied to the error signal for BLDC drive. For this purpose, minimum description length (MDL) data criterion is selected to be the best WT filter. The optimal number of WT coefficients to be retained for signal reconstruction and can be mathematically expressed as below [19]:

$$MDL(k, n) = \min \left\{ \frac{3}{2} k \log N + \frac{N}{2} \log \left\| \widetilde{\alpha}_n - \alpha_n^{(k)} \right\|^2 \right\}, \quad (13)$$

$$0 < k < N; \quad 1 \leq n \leq M$$

where,  $\widetilde{\alpha}_n = W_n f$  denotes a vector of the WT transformed coefficients of the signal  $f$  using WT filters ( $n$ ),  $\alpha_n^{(k)} = \Phi^K \widetilde{\alpha}_n = \Phi^K (W_n f)$  denotes a vector that contains  $k$  nonzero elements. The threshold parameter  $\Phi^K$  keeps a  $k$  number of the largest elements of the vector  $\widetilde{\alpha}_n$  constant and sets all other elements to zero. Where, letters  $N$  and  $M$  denote the length of the signal and the number of WT filters, respectively. By MDL criterion, the orthogonal WT filter ‘db4’ of Daubechies is selected for implementing the IFOC speed controller for this investigation study.

### 3.2. Levels of Decomposition

The number of levels of decomposition represents the gains of the controller and for deducing this; an entropy based criterion was used. The entropy  $H(x)$  of a signal  $x[n]$  of length  $N$  is defined as below [10, 19]:

$$H(x) = - \sum_{n=0}^{N-1} |x(n)|^2 \log |x(n)|^2. \quad (14)$$

To determine the optimal levels of decomposition, the entropy is evaluated at each level and a new level  $j$ , if as follows:

$$H(x)_j \geq H(x)_{j-1} \quad (15)$$

Further, the level  $j$  is omitted from the DWT tree. For this proposed investigation, 2-levels of decomposition is more sufficient and effective to represent error signal [11-14].

### 3.3. Wavelet Controller for Electronic Differential of Electric Vehicle

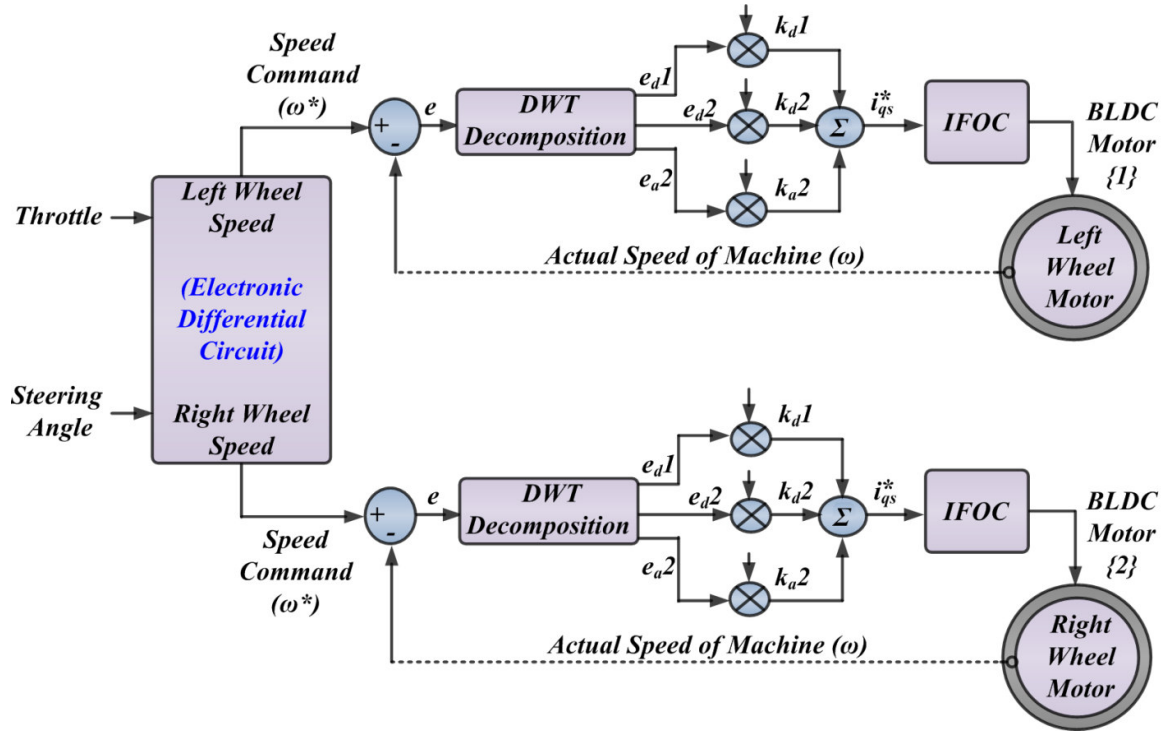

Fig. 5. Schematics of the proposed novel WT based IFOC for electronic differential of two BLDC motors.

Fig. 5 show the control schematic of the WT IFOC speed controller for two BLDC motor connected to rear wheels of the electrical vehicle. The throttle position and steering angle were given as input for the electronic differential which generates the desired speed for the both left- and right-motor. The error detector compares the desired speed and actual speed, generates the error speed which will be used by the WT controllers to generate the control signal for the IFOC two BLDC motor drive systems.

By the WT Controller the error signal is decomposed into for its detailed (high frequency) and approximated (low frequency) components [11-14, 17, 21-22]. Again, these components are scaled by their respective gains and then added together to generate the control signal  $u$  as below:

$$u = k_{d^1}e_{d^1} + k_{d^2}e_{d^2} + \dots + k_{d^N}e_{d^N} + k_{a^N}e_{a^N} \quad (16)$$

where, gains  $k_{d^1}, k_{d^2}, \dots, k_{d^N}$  are used to tune the high and medium frequency components of the error signal ( $e_{d^1}, e_{d^2}, \dots, e_{d^N}$ ). Whereas, gain  $k_{a^N}$  is used to tune the low frequency components of the error signal ( $e_{a^N}$ ) and  $N$  is the number of decomposition levels.

To be noted that the gain values of approximation coefficients ( $k_{a^N}$ ) are responsible for controller functioning. Therefore, lesser approximation gain value lesser the peak over-shoot. The gain values of detailed coefficients ( $k_{d^1}, k_{d^2} \dots k_{d^N}$ ) are only used for controlling high frequency signals which are produced in the system due to sensor noise signals and these gain values do not affect the output speed in ideal noise free conditions [13-14, 21-22].

#### 4. Numerical Simulation Test Results and Discussions

For illustrating the performances of WT controller, the parameters of the two identical BLDC motors are taken with 2hp, 460V, 60Hz, 1750rpm rating, PWM sampling time of 0.5 $\mu$ sec. Three different testing strategies are designed to obtain the characteristics of the electronic differential for the proposed WT electric vehicle system, where two motors are attached to the rear wheels. Investigation is carried out in particular, under different road conditions with different speeds limits of control. Complete model of the system is numerically implemented in Matlab/Simulink simulation software, where PID and WT control algorithm are tested for electric drive system for its comparative performances.

##### 4.1 Investigation Test Strategy-I

TABLE I. DESIGN PARAMETER FOR NUMERICAL SIMULATION TEST-I.

	Time Vector [s]	Amplitude [Km/Hr.) and Angle (Deg)
Speed Input	[0 0.2 0.3]	[60 60 60]
Steering Angle Input	[0 0.2 0.3]	[0° 30° 30°]

In first investigation test typically illustrates the straight road followed by a curved road on the right in clockwise direction at a constant speed of 60km/hr. To be noted, during the turn the speeds of the wheels changes according to the command from the electronic differential. For

this purposes, the amplitudes and respective time of the speed and steering angle inputs are designed as per the strategy given by Table I.

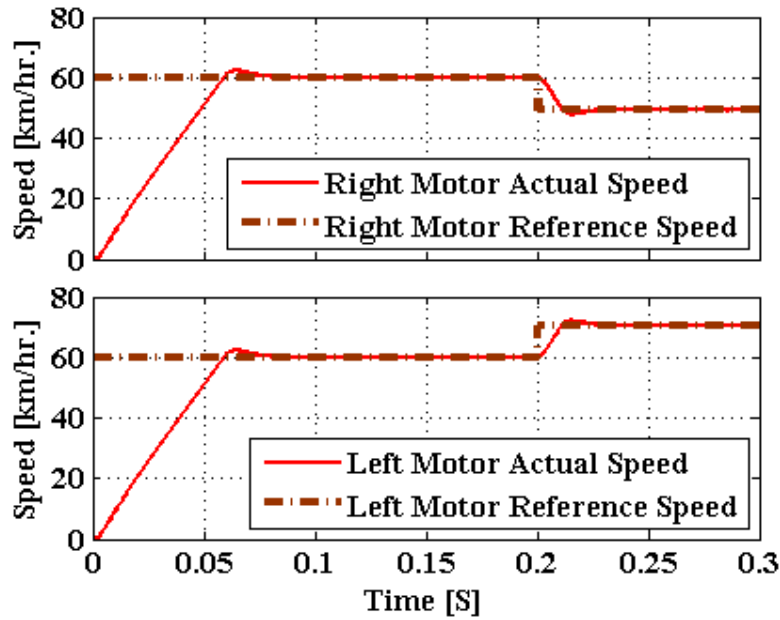

Fig. 6. Numerical simulation test-I output response behaviour of BLDC motors by the PID controller. Motor-1 (top), Motor-2 (bottom).

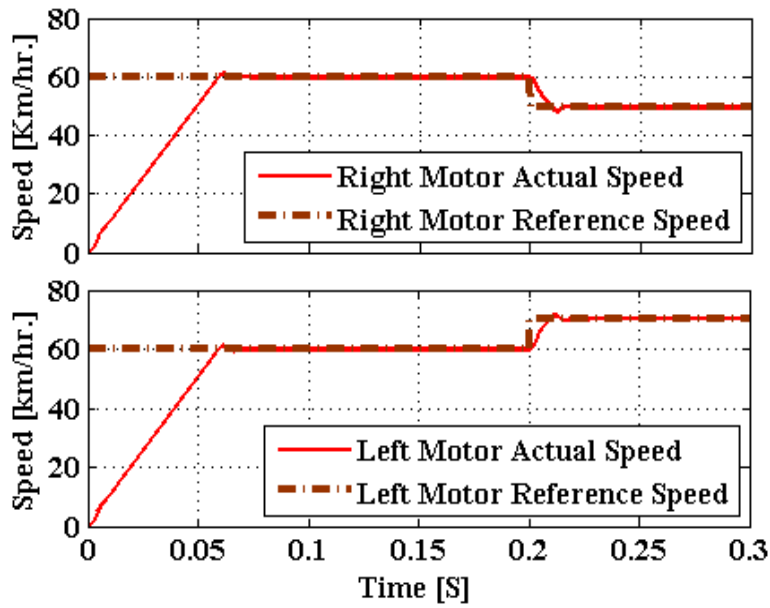

Fig. 7. Numerical simulation test-I output response behaviour of BLDC motors by the WT controller. Motor-1 (top), Motor-2 (bottom).

Fig.3 (PID controller) and Fig.4 (Wavelet controller), it is observed from the simulation test results that WT controller based electronic differential offers smooth performance compared to

standard PID Controller. Moreover, the WT based electronic differential offers lesser overshoot (60.99km/hr) and settles quickly (0.07sec) in comparison to PID controller electronic differential (63km/hr, 0.09sec). Therefore, it is confirmed that the left and the right motors produced smooth control with better turning performance of the electric vehicle by WT.

#### 4.2 Investigation Test Strategy-II:

In second investigation test typically illustrates the straight road followed by a curved road on the left in counter-clockwise direction at a constant speed of 60km/hr. To be noted, during the turn the speeds of the wheels changes according to the command from the electronic differential. For this purposes, Table II provides the design strategy for the amplitudes and respective time of the speed and steering angle inputs.

TABLE II. DESIGN PARAMETER FOR NUMERICAL SIMULATION TEST-II.

	Time Vector [s]	Amplitude [Km/Hr.] and Angle (Deg)
Speed Input	[ 0 0.2 0.3 ]	[60 60 60]
Steering Angle Input	[ 0 0.2 0.3 ]	[0° -30° -30°]

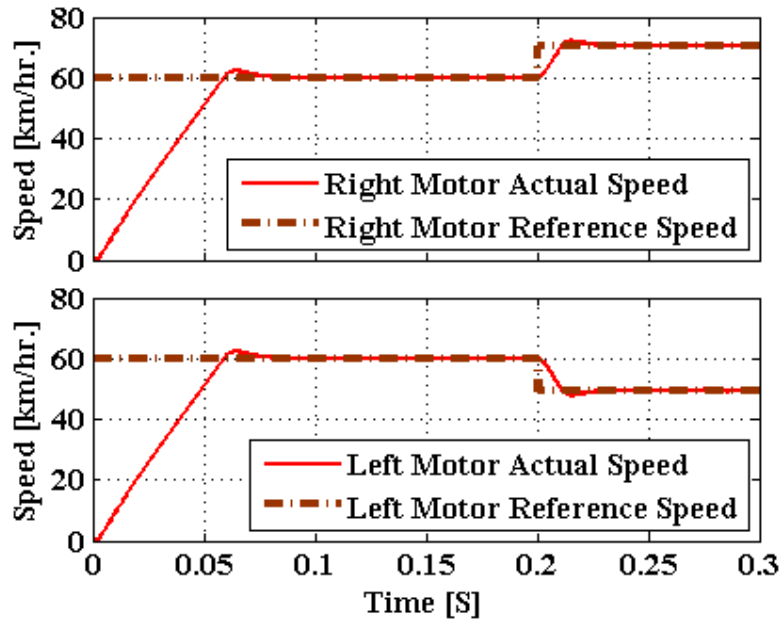

Fig. 8. Numerical simulation test-II output response behaviour of BLDC motors by the PID controller. Motor-1 (top), Motor-2 (bottom).



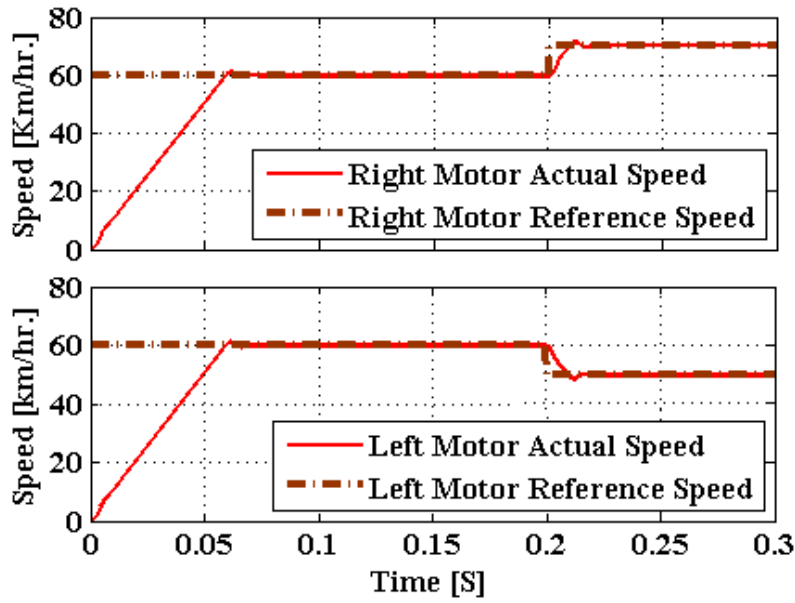

Fig. 9. Numerical simulation test-II output response behaviour of BLDC motors by the WT controller. Motor-1 (top), Motor-2 (bottom).

By investigation test-II it is expected and confirmed from the simulation results that WT controller (Fig. 8) based electronic differential offers smooth performance compared to standard PID Controller (Fig. 9). WT based electronic differential retains the same lesser overshoot (60.99km/hr) and settling time (0.07sec) in comparison to PID controller electronic differential (63km/hr, 0.09sec) as like previous test-I. This investigation test again confirms that the left and the right motors produced smooth control with better turning performance of the electric vehicle by WT.

#### 4.3 Investigation Test Strategy-III:

TABLE III. DESIGN PARAMETER FOR NUMERICAL SIMULATION TEST-III.

	Time Vector [S]	Amplitude [Km/Hr.] and Angle (Deg)
Speed Input	[ 0 0.2 0.4 0.6 0.7 ]	[60 60 30 60 60]
Steering Angle Input	[ 0 0.2 0.4 0.6 0.7 ]	[0° 0° 30° 0° 0°]

In third investigation test typically illustrates the straight road with a constant speed of 60km/hr., followed by a right turn 30° at 30km/hr.; followed by a straight road at a constant speed of 60km/hr. For this purposes, the amplitudes and respective time of the speed and steering angle inputs are designed as per the strategy given by Table II.

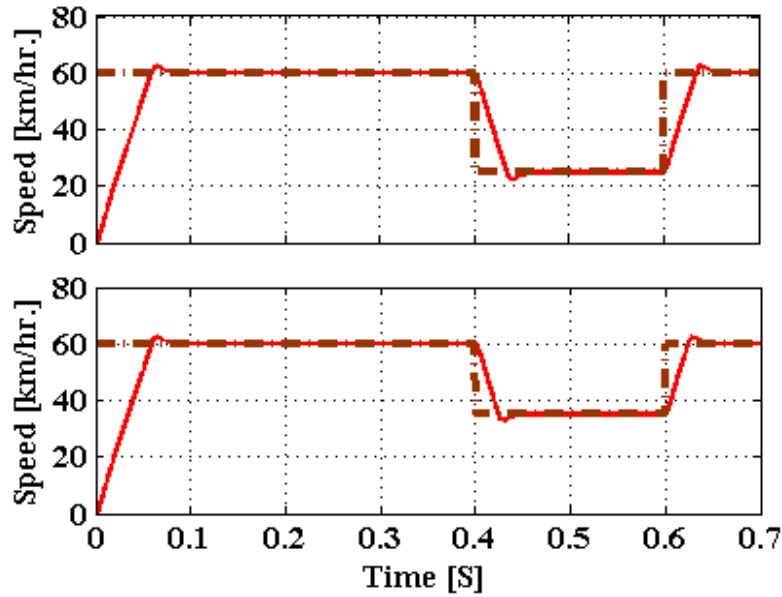

Fig. 10. Numerical simulation test-III output response behaviour of BLDC motors by the PID controller. Motor-1 (top), Motor-2 (bottom).

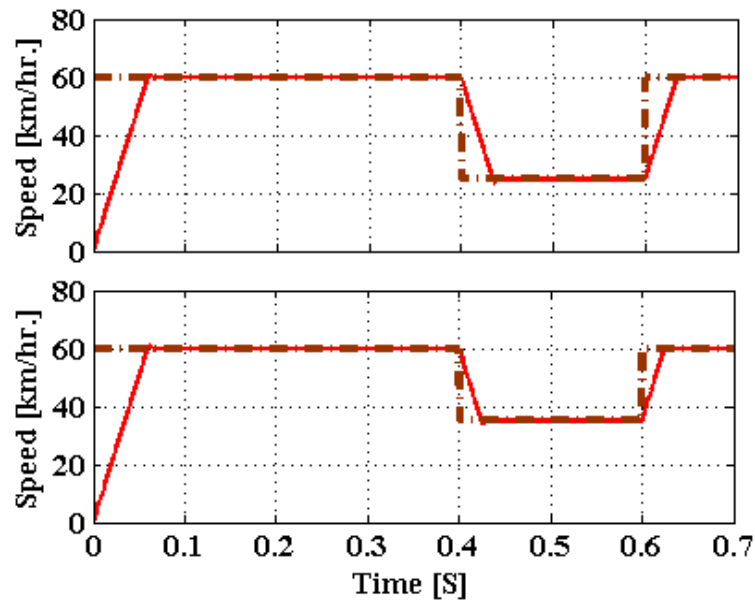

Fig. 11. Numerical simulation test-III output response behaviour of BLDC motors by the WT controller. Motor-1 (top), Motor-2 (bottom).

As expected also in investigation test-III from the simulation results that WT controller (Fig. 10) based electronic differential offers smooth performance compared to standard PID Controller (Fig. 11). Further, the WT based electronic differential retains the same lesser overshoot (60.99km/hr) and settling time (0.07sec) in comparison to PID controller electronic differential (63km/hr, 0.09sec). Again by this investigation test it is confirmed that the left and

the right motors produced smooth control with better turning performance of the electric vehicle by WT.

To show the effectiveness of the peak over-shoot and setting time of the obtained speed response by WT, zoomed view of transient and steady-state response of both WT and PID controllers are shown in Fig. 12 and Fig. 13.

Further, comprehensive performances indices obtained by investigation tests are detailed in Table IV. It is clearly visible that WT controller shown superiority by lesser peak over-shoot, quick settling time, minimized steady-state error and optimal root-mean square error value (RMSE) than PID controller to propagate smoothly two BLDC motor driven electrical vehicle.

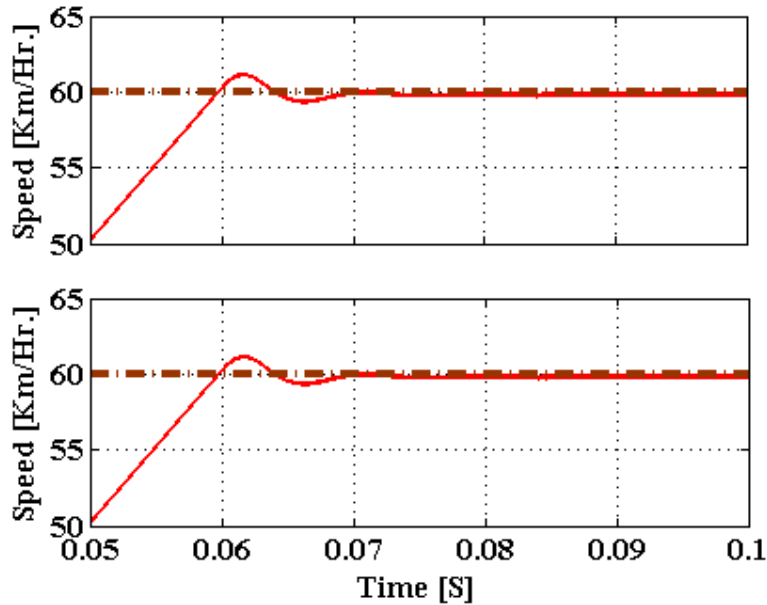

Fig. 12. Transient and peak over-shoot zoomed view of output response behaviour of BLDC motors by the WT controller. Motor-1 (top), Motor-2 (bottom).

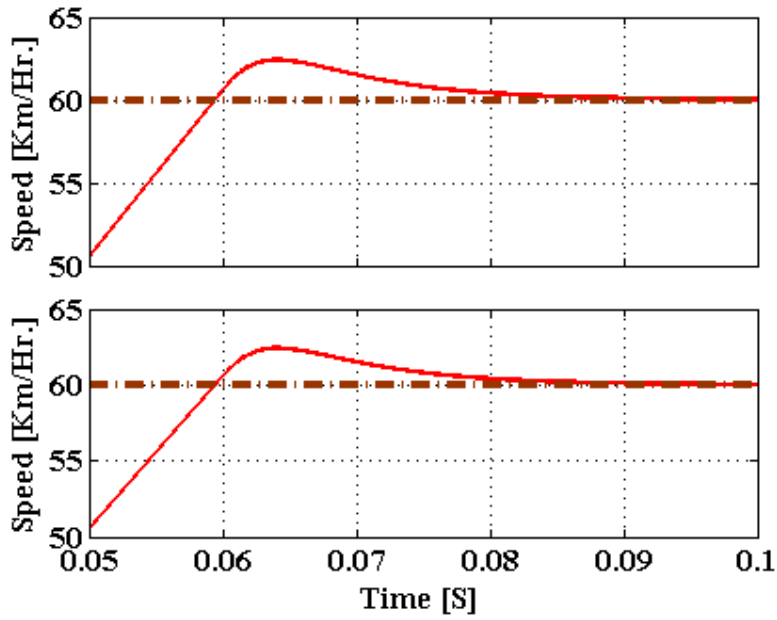
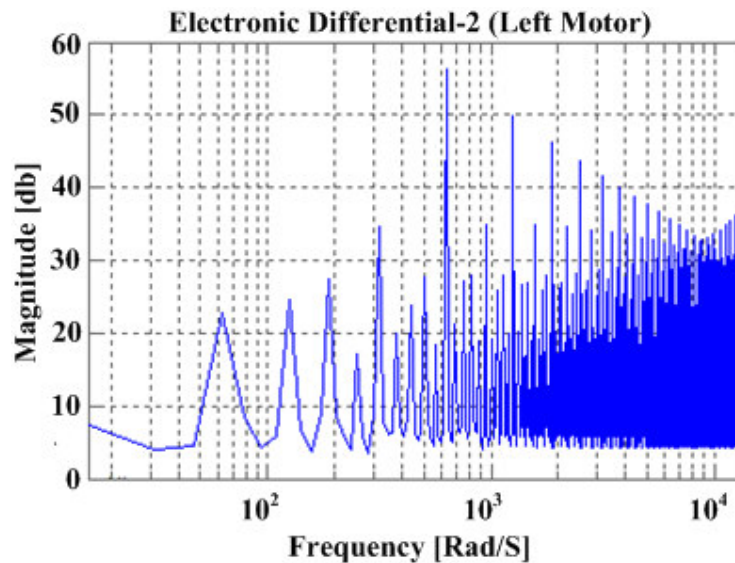

Fig. 13. Transient and peak over-shoot zoomed view of output response behaviour of BLDC motors by the PID controller. Motor-1 (top), Motor-2 (bottom).

TABLE IV. COMPARATIVE PERFORMANCE OF THE CONTROLLER IN TIME DOMAIN PARAMETERS.

Specifications		Test-I		Test-II		Test-III	
		PID	WT	PID	WT	PID	WT
% Peak Over-shoot		1.05	1.01	1.05	1.01	1.05	1.01
Settling Time [S]		0.09	0.068	0.09	0.068	0.09	0.068
Steady-State Error [Km/Hr.]		0.34	0.08	0.34	0.08	0.34	0.08
Root-Mean Square Error (RMSE)	Left Motor	33.28	16.11	33.28	16.11	33.28	16.11
	Right Motor	33.28	16.11	33.28	16.11	33.28	16.11



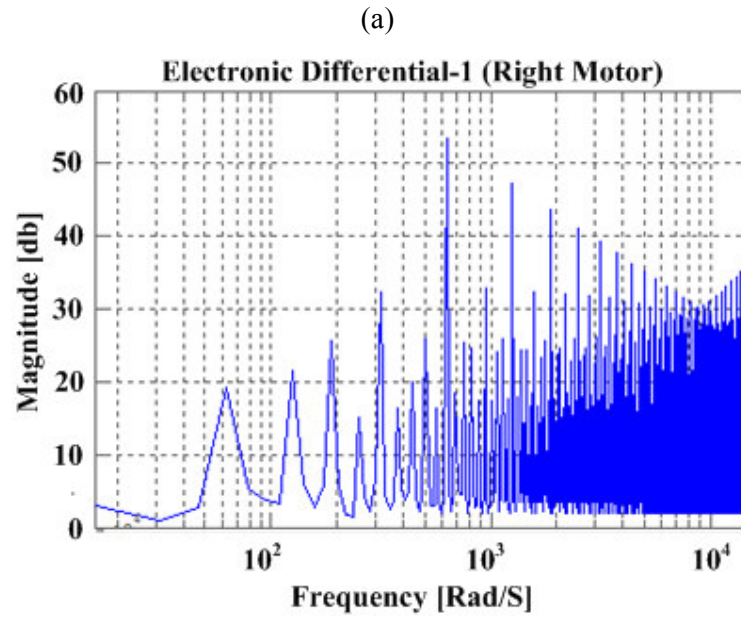

Fig. 14. Frequency domain (Bode plot) response for electronic differential control, (a) left motor and (b) right motor.

Finally, both right and left BLDC motors controlled by WT is analyzed using bode plot for its stability for continuous smooth propagation. Fig. 14(a) and Fig. 14(b) represent the magnitude response plots for left and right BLDC motors respectively. By analyzing the frequency response curves, it is concluded that the proposed WT signals having high positive gain- and phase-margin at different frequency spectrum for both right and left BLDC motors which is actually connected in rear wheels of electric drive. Hence, it ensures the stability of electric vehicle drive propagation in normal and curved roads by the proposed WT IFOC controller.

## 5. Conclusion

This work articulated the design of an electronic differential control for electric vehicle utilizing WT based indirect field oriented control (IFOC) speed controller. Standard PID controller of the electronic differential are been replaced by the 2-level discrete WT transform. Investigation are carried out under set of designed test strategies by varying speed and steering angle inputs, and the obtained performances are compared between both WT and PID controller. Numerical simulation test results provided in this article proves the effectiveness of the proposed WT

electronic differential by smooth control with minimal peak over-shoot and quick settling time than PID. Finally, the WT stability in speed control of the electric vehicle is ensured by bode plot analysis. Complete investigation test strategies confirm that WT electronic differential are suitable for electric vehicles for smooth propagation on curved roads.

## References

- [1] A.M.Guillermo, H.D.A.Cristian, B.Guillermo, G.Guillermo, “A neighbourhood electric vehicle with electronic differential traction control”, *Proc. 34<sup>th</sup> Annual Conf. IEEE Ind. Electron., IEEE-IECON’08*, Orlando (USA), pp. 2757-2763, 10-13 Nov. 2008.
- [2] R.P. de Castro, H.S.Oliveira, J.R.Soares, N.M.Cerqueira, R.E.Araujo, “A new FPGA based control system for electrical propulsion with electronic differential”, *Proc. IEEE European Conf. Power Electronics and Applications, IEEE-EPE’07*, Aalborg (Denmark), pp. 1-10, 2-5 Sept. 2007.
- [3] Y.E.Zhao, J.W.Zhang, X.Q.Guan, “Modelling and simulation of electronic differential system for an electric vehicle with two-motor-wheel drive”, *Conf. Proc. IEEE Intelligent Vehicles Symposium*, Xi'an (China), pp. 1209 – 1214, 3-5 June 2009.
- [4] A. Draou, “Electronic differential speed control for two in-wheels motors drive vehicle”, *Proc. IEEE 4<sup>th</sup> Intl. Conf. Power Engg. Energy Elect. Drives, IEEE-POWERENG’13*, Istanbul (Turkey), pp. 764-769, 13-17 May 2013.
- [5] F.Chunyun, R.Hoseinnezhad, R. Jazar, A.Bab-Hadiashar, S.Watkins, “Electronic differential design for vehicle side-slip control”, *Proc. IEEE Intl. Conf. Control, Automation and Information Sciences, IEEE-ICCAIS’12*, Ho Chi Minh (Vietnam), pp. 306-310, 26-29 Nov. 2012.
- [6] H.Kahveci, H.I.Okumus, M.Ekici, “An electronic differential system using fuzzy logic speed controlled in-wheel brushless dc motors”, *Proc. IEEE 4<sup>th</sup> Intl. Conf. Power Engg.*

*Energy Elect. Drives, IEEE-POWERENG'13*, Istanbul (Turkey), pp. 881-885, 13-15 May 2013.

- [7] P.N.Huu, "Design of an electronic differential for a formula electric race car", *Proc. IEEE Intl. Conf. Electric Machines & Drives Conference, IEEE-IEMDC'13*, Chicago (USA), pp. 62-66, 12-13 May 2013.
- [8] S.A.Saleh, M.Azizur Rahman, "Experimental Performances of the Single-Phase Wavelet-Modulated Inverter", *IEEE Trans. on Power Electron.*, vol. 36, no. 9, pp. 2650-2661, Sept. 2011.
- [9] S.A.Saleh, "The Implementation and Performance Evaluation of  $3\Phi$  VS Wavelet Modulated AC-DC Converters", *IEEE Trans. on Power Electron.*, vol. 28, no. 3, pp. 1096-1106, March 2013.
- [10] M.A.S.K.Khan, M.A.Rahman, "Implementation of a new wavelet controller for interior permanent magnet motor drives", *IEEE Trans. Ind. Appl.*, vo. 44, pp. 1957-1965, 2008.
- [11] P.Sanjeevikumar, J.L.Febin Daya, Frede Blaabjerg, Nazim Mir-Nasiri, Ahmet H.Ertas, "Numerical Implementation of Wavelet and Fuzzy Transform IFOC for Three-Phase Induction Motor", *Engineering Science and Technology: An International Journal (JESTECH)*, Elsevier Journal Publications, 14 August 2015. doi: 10.1016/j.jestech. 2015. 07.002
- [12] P.Sanjeevikumar, J.L.Febin Daya, Frede Blaabjerg, Patrick Wheeler, Valentin Oleschuk, Ahmet H.Ertas, Nazim Mir-Nasiri, "Wavelet-Fuzzy Speed Indirect Field Oriented Controller for Three-Phase AC Motor Drive-Investigation and Implementation", *Engineering Science and Technology: An International Journal (JESTECH)*, Elsevier Journal Publications, 2015.
- [13] J.L.Febin Daya, V.Subbiah, P.Sanjeevikumar, "Robust Speed Control of an Induction Motor Drive using Wavelet-fuzzy based Self-tuning Multi-resolution

- Controller”, *International Journal of Computational Intelligence System (IJCIS)*, Atlantis Press and Taylor & Francis publications, vol.6, No. 4, pp.724–738, 10 May 2013.
- [14] J.L.Febin Daya, V.Subbiah, Atif Iqbal, P.Sanjeevikumar, “A Novel Wavelet-Fuzzy based Indirect Field Oriented Control of Induction Drives”, *Journal of Power Electronic (JPE)*, The Korean Institute of Power Electronics, Seoul (Republic of Korea), vol. 13, pp. 656–668, No.4, July 2013.
- [15] Y-C.Hung, F-J.Lin, J-C.Hwang, J-K.Chang, K-C,Ruan, “Wavelet Fuzzy Neural Network With Asymmetric Membership Function Controller for Electric Power Steering System via Improved Differential Evolution”, *IEEE Trans. on Power Electron.*, vol. 38, no. 4, pp. 2350-2362, April 2014.
- [16] C.Sun, S.J.Moura, X.Hu, J.K.Hedrick, F.Sun, “Dynamic Traffic Feedback Data Enabled Energy Management in Plug-in Hybrid Electric Vehicles”, *IEEE Trans. on Power Electron.*, vol. 23, no. 3, pp. 1075-1086 May 2015.
- [17] Hui Liu, Poh Chiang Loh, Frede Blaabjerg, “Sub-module Short Circuit Fault Diagnosis in Modular Multilevel Converter Based on Wavelet Transform and Adaptive Neuro Fuzzy Inference System” *Journal of Electric Power components and Systems*, Taylor and Francis Journal, vol. 43, no. 8-10, pp. 1080-1088, May 2015.
- [18] M.Khan, M.A.Rahman, “A Novel Neuro-Wavelet-Based Self-Tuned Wavelet Controller for IPM Motor Drives”, *IEEE Trans. Ind. Electron.*, vol. 46, no. 3, pp. 1194-1203, May-June 2010.
- [19] E.Y.Hamid, Z.I.Kawasaki, “Wavelet-based data compression of power system disturbances using the minimum description length criterion”, *IEEE Trans. On Power Delivery*, vol. 17, no. 2, pp. 460-466, April 2002.
- [20] S.G.Mallat, “A theory for multi-resolution signal decomposition: The wavelet representation,” *IEEE Trans. Pattern Anal. Mach. Intell.*, vol. 11, no. 7, pp. 674–693, Jul. 1989.



- [21] L. Coppola, L. Qian, S. Buso, D. Boroyevich, A. Bell, "Wavelet transform as an alternative to the short-time Fourier transform for the study of conducted noise in power electronics", *IEEE Trans. Ind. Electron.*, vol. 55, no. 2, pp. 880–887, Feb. 2008.
- [22] P.Sanjeevikumar, J.L. Febin Daya, Patrick Wheeler, Frede Blaabjerg, Viliam Fedák, Olorunfemi Ojo, "Wavelet Transform with Fuzzy Tuning Based Indirect Field Oriented Speed Control of Three-Phase Induction Motor Drive", *Conf. Proc. The 18th IEEE Intl. Conf. on Electrical Drives and Power Electronics, IEEE-EDPE'15*, Slovakia Republic, 21–23 Sept. 2015.