

Real-time Optimisation of a Microwave Plasma Gasification System

B. Kabalan, S. Wylie, A. Mason, A. Shaw, R. Al-khaddar and A. Al-Shamma'a

RF Microwave Group, Built Environment and Sustainable Technologies Research Institute,
School of Built Environment, Liverpool John Moores University, Liverpool, UK

C. Lupa, B Herbert and E Maddocks

Stopford Energy & Environment Ltd, The Gordon Manley Building, Lancaster Environment
Centre, Lancaster University, Lancaster, UK.

B.kabalan@2009.ljmu.ac.uk

Abstract. A microwave plasma gasifier has been designed to produce syngas from waste. Gasification using microwave plasma has various controllable parameters to achieve optimal syngas production. These parameters include the microwave power applied, the reflected power from the microwave plasma jet, the EH tuner arm position, the gas flow and pressure, in addition to the temperature inside the gasifier. A variety of sensors are required to provide feedback and control for each of these parameters. This paper discusses the benefits of gasification, particularly via microwave plasma techniques, the first steps toward the optimisation of such a system and some preliminary results of this optimisation.

1. Introduction

The general definition of gasification is the conversion of any carbonaceous feedstock “fuel” to gaseous products using partial oxidation. The main product of this partial oxidation is synthesis gas or syngas; it consists of hydrogen (H_2) and carbon monoxide (CO). The Syngas is later cleaned-up and further processed to produce chemicals, fertilisers, liquid fuel and electricity [1]. The feedstock that is converted to syngas can be derived from hydrocarbon materials. Coal was the first feedstock to be used in the gasification process, but due to demand of sustaining the earth resources, other types of feedstock are being used; biomass is in use at the moment which includes corn stover, sawdust, wood [2], and most importantly food waste. Feedstocks undergo several chemical reactions to produce syngas, some of which are exothermic and some are endothermic [3]. Gasification technology gives the advantage of getting energy from a low cost and otherwise useless waste, and recycles it at the same time. However, the novelty of this procedure is getting maximum energy levels from the system when using minimum input (i.e. power), thus optimising this procedure would be vital for efficiency and this is the aim of our study.

Plasma is defined as the fourth state of matter. If the temperature of a solid substance increased to or above a certain degree, it eventually transforms to plasma (passing through liquid and gas); the bonds between the electrons and ions are broken in that state of matter and the gas becomes electrically conducting plasma [4]. Plasma discharge has three main categories, and can be listed as follows depending on the source used [5-6];

- DC plasma
- AC plasma
- Microwave plasma

The differences between DC – AC and microwave plasma are that both AC and DC plasma need electrodes and high power to ensure the electron jump from the cathode surface to the anode, thus ionising a gas atom while in microwave plasma the technique is different, the electric field ionises the gas atoms without the need of the electrode.

Microwaves are electromagnetic waves that have frequency range from (0.3-300) GHz [7]. In order to transmit a high frequency wave, a waveguide is needed. Waveguides are the transmission lines for microwaves and have different shapes; each one has its own characteristics and mode of propagation [8]. However, the shape used to create plasma in this paper is rectangular waveguide.

The key component of the system is the microwave plasma jet which has advantages over typical DC plasma jet. These advantages can be listed as [9]:

- The plasma jet properties and quality is stable comparing to the DC plasma, as it has no electrode and therefore no electrode vapour contamination.
- The nozzle electrode erosion is ignored as the nozzle stays relatively cold since the plasma is operated in the open air at the tip of the nozzle.
- Cheaper requirements to create the plasma; the magnetron power supply is robust and cheap (any commercial microwave oven would do).

2. Experimental System

The gasification system is shown in figure 1(left). It consists of a magnetron power supply, a circulator, a water-cooled matched load, a tuning system (E-arm and H-arm), a plasma cavity (which contains a nozzle where the plasma is created using argon) and the gas chamber. The creation of the plasma is achieved by using a microwave power source (1.1KW, 2.45 GHz) and argon gas passing through the nozzle inside the chamber. When the electric field is strong enough at the nozzle, argon molecules are ionised and Argon is turned to plasma [10]. The adjustment of the tuning system affects the electric field at the nozzle and the optimal position of the arms is when the electric field is at its maximum at the nozzle. Figure 1 (right) shows the E and the H arm of the tuner system; they are automatically controlled by a stepper motor mounted on the top of each arm.

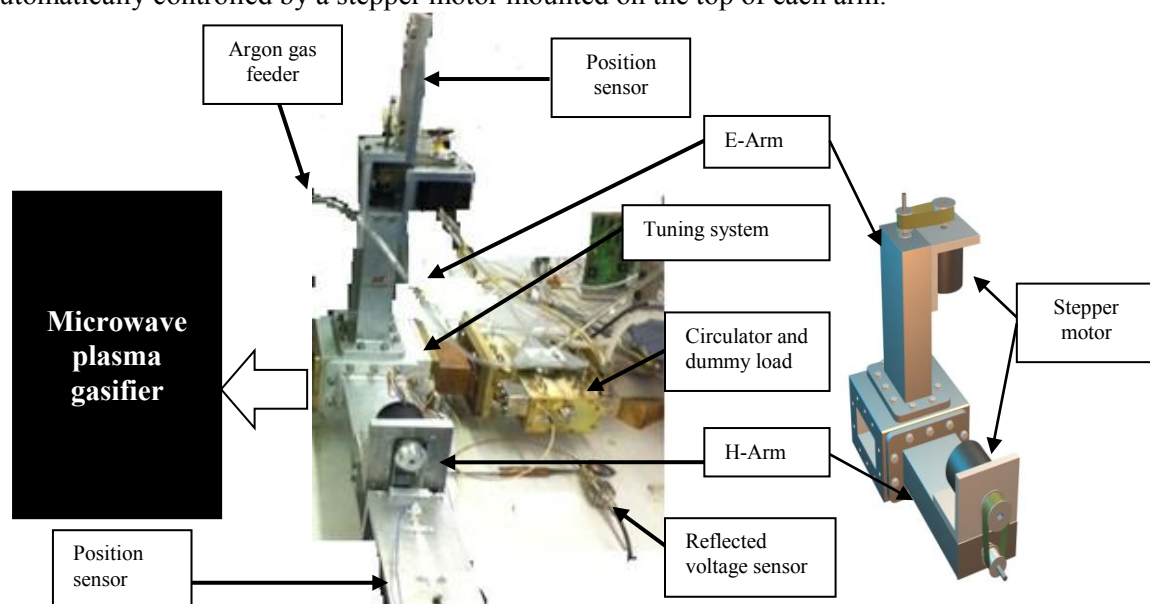

Figure 1. Overview of the (left) gasification system and (right) the tuning section.

In order to optimise the gasification procedure and increase the efficiency of the syngas production, a control and sensing system is implemented. This system's block diagram is shown in figure 2 and includes;

- Position sensor and control,
- Voltage sensor (Microwave detector diode),
- Gaset gas analyser,
- LabVIEW interfaces and control circuit.

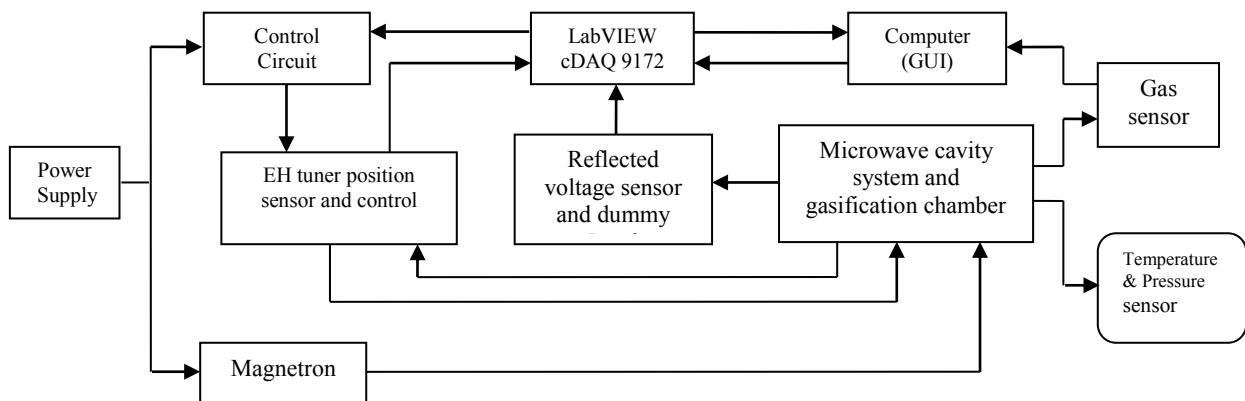

Figure 2. The control and the sensing system's block diagram.

The gasification procedure is a thermo-chemical one, thus a relatively hot microwave plasma jet is used to break the feedstock into its basic components. The plasma is created by an argon flow through a high electromagnetic field generated by the magnetron using a frequency of 2.45GHz. However, this plasma needs to be optimised in order to use its full power and generate syngas. This is achieved by the implemented sensing and control system, where the reflected power is sensed by a microwave detector (S-team diode detector) and accordingly the tuning system is adjusted to decrease this reflected power to its minimal levels. The tuning system has two arms (E and H arms), these arms control the electric and the magnetic field respectively and can be sit in a range between (0-100)mm. The tuning arms are used to adapt the impedance change when the plasma first ignites. Experiments show that once the plasma has struck, it affects the system load matching and thus the reflected power is increased. In order to keep the reflected power to a minimum level, the tuning system via the two arms plays a key role by changing the inner dimensions of the waveguide.

The generated gases from the gasified feedstock are sensed using Gaset gas analyser (figure 3) and monitored by a LabVIEW program (figure 5) which is programmed to monitor and control the gasification procedure. The LabVIEW GUI is connected to the system via DAQ's and control circuits (figure 4). The data acquisition boards are compatible with LabVIEW programming and they feedback to the GUI the arms position, the reflected power and sends to the system control signals. The pressure inside the gas chamber is monitored by a gas sensor gauge and has a relief security valve to release the pressure when it rises above 300 mbar. Temperature effects on optimising the production of syngas, by introducing temperature sensors and pressure control, are ongoing and will be reported upon in a subsequent publication

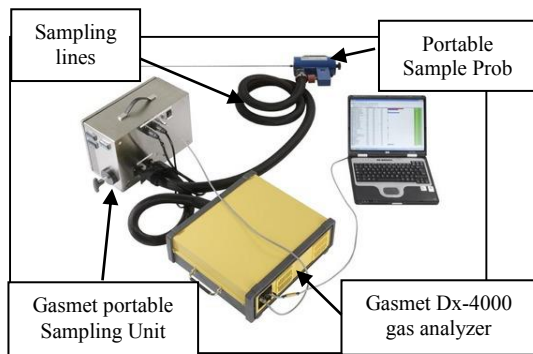

Figure 3. Gaset gas analyser

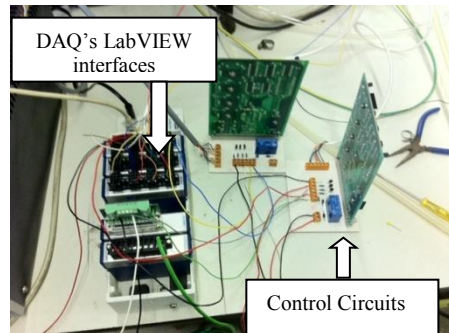

Figure 4. Control circuits

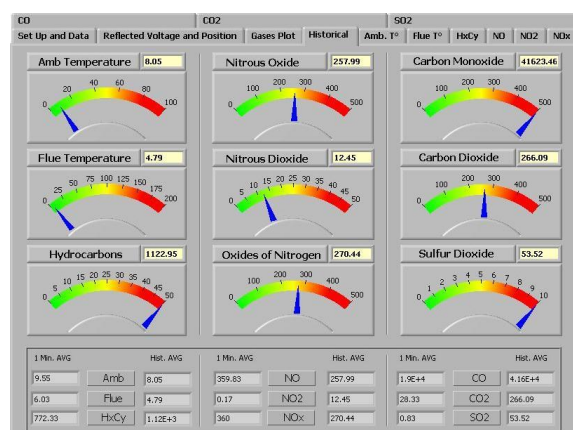
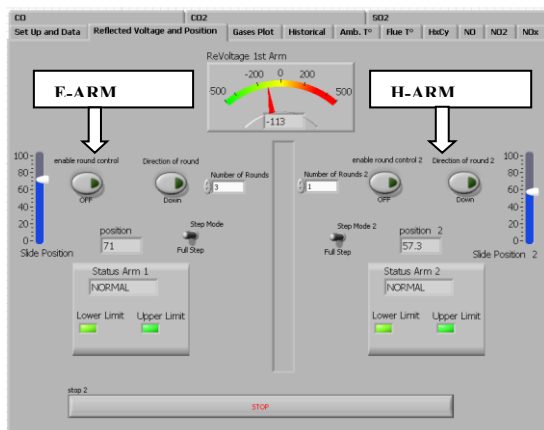

Figure 5. LabVIEW GUI for controlling and monitoring.

3. Experimental Results

Experiments were conducted using 30g pieces of dried wood and the results analysed with and without optimisation which is achieved by the control system to compare the efficiency. The pressure inside the chamber was fixed on 100 mbar and argon flow fixed on 1 L/min.

Figure 6 shows a sweep of E-arm along all possible positions to study the behaviour of the plasma. For each position of the arm, a reflected voltage is recorded and converted to reflected power. It can be noted that the plasma first strikes when the arm position is 82 mm where the reflected voltage is recorded at -360 mV giving reflected power of 4.2 dBm. Directly after the plasma is struck, the reflected power is increased and the arms start to change their position until the reflected voltage is minimised and this optimal position occurs at 54 mm with reflected voltage around -100 mV.

Figure 7 shows a study of two samples of wood, the first sample was gasified without using the optimisation system while sample 2 was gasified using the control system to track the optimal position. We studied the efficiency of the gasification procedure depending on carbon monoxide concentration and CO/CO₂ ratio in addition to the time needed for the gasification procedure. The sample gasified without automatic control took more time (460 seconds) and gave less CO percentage (1.04 %) compared to the optimised automatically controlled gasification method (table I).

The average gas concentrations using the same piece of wood are shown in figure 6. A small amount of greenhouse gases and acid rain gases (SO₂, NO₂, N₂O) are emitted using this procedure which satisfy the environmental limits and give a clean and green way to produce energy.

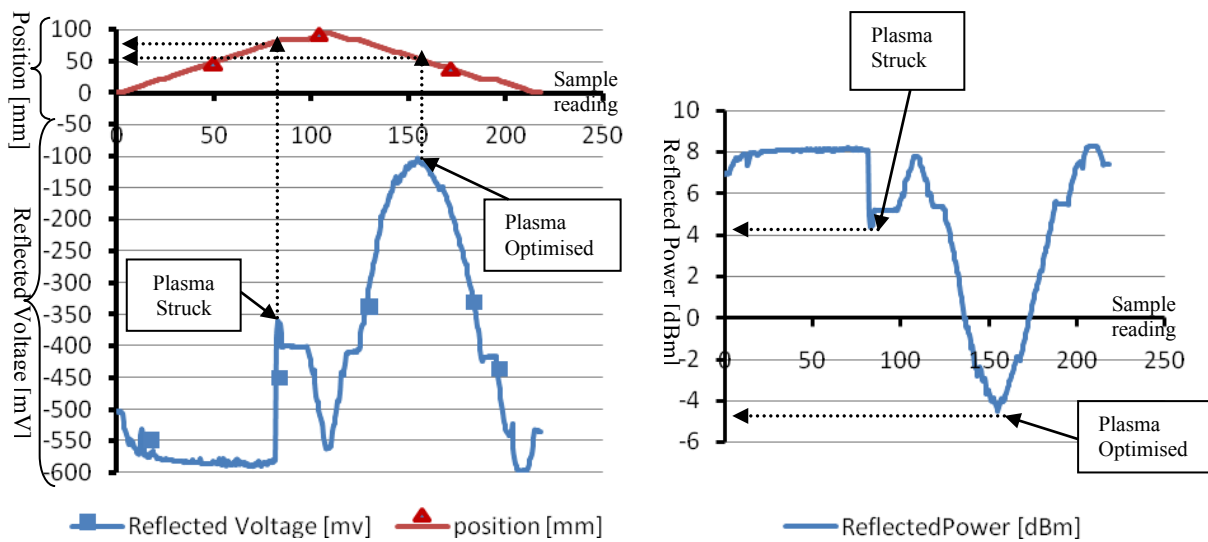

Figure 6. E-arm sweep and plasma behaviour.

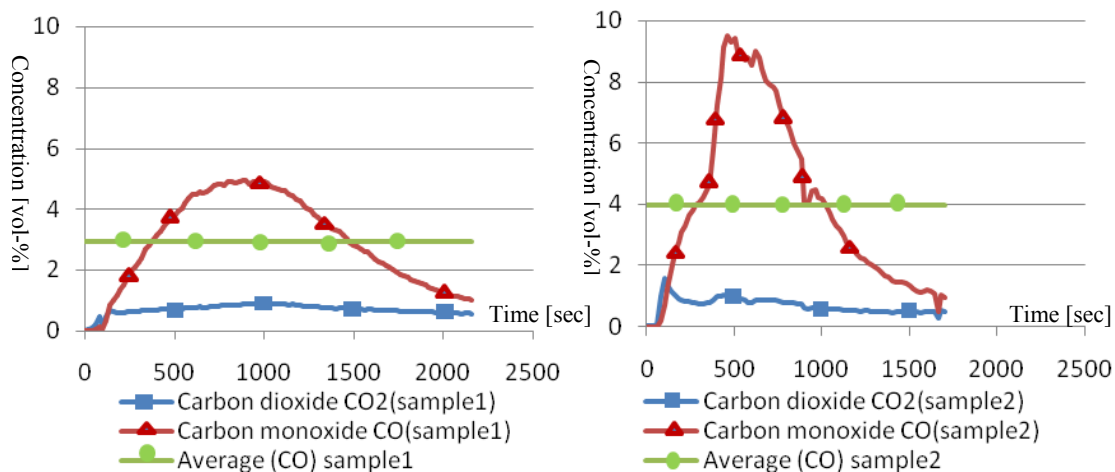

Figure 7. A comparison between a non-optimised (sample 1) and optimised (sample 2) gasification.

These figures are a clear evidence of the need and the benefit of the control and optimisation system in the gasification process. It helps in obtaining larger amounts of syngas components in shorter time, thus increases the efficiency of the process.

Table 1. Sample comparison

Sample	Condition	Weight before gasification [g]	Weight after gasification [g]	Time elapsed [s]	CO concentration [vol-%]	Reflected voltage [mV]	Reflected power [dBm]	CO/CO ₂ ratio
Sample 1	No automatic control	30	11	2160	2.91	140-145	-2.5,-2.2	4.2
Sample 2	Automatic control	30	9	1700	3.95	90-95	-5.4,-5.1	5.81

4. Conclusion and Future Work

Gasification is the future green energy source as it can provide different kinds of energy products using waste feedstock, which in return would help solving the landfill problem and save the earth's resources. However, this procedure needs various controls and monitoring to achieve best results. This paper presented the sensing and the control system and the outcome gases analysis. It showed the benefit of using the control system to optimise the gasification procedure and compared the results with and without the control system. However, this system still needs some other sensing and control; a temperature sensor is still to be introduced to the system and a pressure control system would make the monitoring easier. It also needs a gas flow control as controlling argon flow affects the plasma density. Moreover, a hydrogen sensor should be attached to the system to give a full image about the syngas components. These sensors would be fitted at the next stage of the system development and a full gas analysis then can be provided.

5. References

- [1] Gasification Technologies Council, '*Gasification: Redefining Clean Energy*', available online: <http://www.gasification.org/> [accessed Oct 2010]
- [2] R. Mark Bricka, Dave C. Swalm, '*Energy Crop Gasification and Gasification Issues*', School of Chemical Engineering Mississippi State University
- [3] Christopher Higman, Maarten van der Burgt, *Gasification*, Gulf Professional Publishing, second edition 2008, pp. 12-15, 33-36
- [4] John Howard, *Introduction to Plasma Physics*, 2002, Australian National University
- [5] A. Ganguli & R.D. Tarey, *Understanding Plasma Sources*, 2002, Current Science, Vol 83, issue 3, pp 279-290.
- [6] Eric Seymour, *Performance Considerations of High-Power AC Plasma Deposition Power Supplies*, 2004, Advanced Energy Industries.
- [7] David M. Pozar, *Microwave Engineering*, 1993, Addison-Wesley publishing Company
- [8] K.F. Sander & G.A.L. Reed, *Transmission and Propagation of Electromagnetic Waves*, 1986, Cambridge University Press
- [9] A. Al-Shamma'a, S.R. Wylie, J. Lucas, & C.F. Pau, *Design and Construction of a 2.45 GHz Waveguide-based Microwave Plasma Jet At Atmospheric pressure for Material Processing*, 2001, Journal of Physics : Applied Physics, vol 34, pp 2730-2735.
- [10] S. Eliezer & Y. Eliezer, *The Fourth State of Matter, An Introduction of Plasma Science*, 2001, IOP Publishing Ltd.

Acknowledgments

The authors would like to thank the Technology Strategy Board, Stopford Energy & Environment Ltd and BEST Research Institute from Liverpool John Moores University for their continuous help and support.