

Ontology Based Structure of an Elective Patient Oriented Performance Flow

Papagiannis A. Fragoulis^{1, 2}, Abdul Roudsari², Konstantinos Danas^{1, 2}

1. The American College of Thessaloniki

papagiannis@cpgconsulting.gr

cdanas@act.edu - www.act.edu

2. Centre for Health Informatics,
City University, London

a.v.roudsari@city.ac.uk - www.city.ac.uk/mim

Keywords

Ontology, patient oriented, performance measures

ABSTRACT

This study, based on enterprise ontology, introduces necessary transactions and results for elective patient oriented flow through all levels of healthcare. This ontology model is of paramount importance as it clearly defines the ambiguous concept of the patient oriented flow. Focus is placed on knowledge management for the use of equality, efficiency and effectiveness principles on both internal and external healthcare environment. Necessary organisational levels, based on enterprise ontology, will also be presented in order to assist in the creation of a measuring framework of leading performance indicators.

INTRODUCTION

Case studies specifically in the Greek healthcare sector showed substantial lack of evidence regarding effective patient oriented practices as well as lack of efficiency and availability in general hospitals. According to a recent study the following equation was taken into consideration:

Equality > Effectiveness > Performance

This equation stresses the role of the public health that should be available for everyone (Tountas, Economou, 2007).

Many national healthcare systems have different approaches to such an issue. For example the above equation was first introduced as:

Effectiveness > Performance > Equality

The hierarchy in this equation shows a different approach proposed by Cochrane (Cochrane, 1972). It is although obvious that both approaches partly consider the equality issue for the healthcare industry.

This study, based on Wolstenholme's patient flow system analysis, attempts to accumulate transactions and results quality measurements and aims to introduce a patient oriented performance measurement system using an ontological approach. Objectives of this study, based on a national health care system strategy, are to measure and store:

- ◆ Patient value added service
- ◆ Patient satisfaction
- ◆ Patient treatment performance.

There are obstacles in establishing cohesive health measurements as the evaluation of quality performance is subjective to clinical measures. Research outcomes, even if they take care of all the complex measurements, are subject to the procedures and methodologies used to collect process and interpret results (Stavert et al., 2003). Enterprise ontology and DEMO methodology will assist in establishing health measurements beyond any subjection. Measurements both internally and externally are important to the concept of patient oriented performance (Ovretveit, 2001). On the other hand international cohesive and quality standards are beyond the aim of this study.

THE NEED FOR AN ONTOLOGY BASED SYSTEM

There is a need for the introduction of a novel system patient flow quality system that could manage and store valuable knowledge in order to measure the patient flow obstacles. This system would have to focus on the life long relationship between patient and healthcare providers and measure its results based on treatment and satisfaction measures considering the overall cost of this relationship. That means that the process of treatment will not be measured based only on transactions, but as a part of the whole healing cycle of the patient. The sum of all the transactions that will lead to treatment results (effectiveness) and also to a competitive cost of treatment (efficiency) will provide valuable knowledge and will set a new level for measuring and restructuring the patient flow.

A priori, the elective patient is an 'on' (from the Aristotle's definition 'ov', something that exists) that is having a series of decisions to make before entering to any process of managing or measuring his treatment flow. The patient is primarily concerned with a clear communication and understanding of the expert opinion. It is most of the times to the system's stakeholders' dominant position to reason such treatment's promise based on evidence produced.

Despite the efforts already made in several ontological disciplines, healthcare organisations are much like business organisations in structure. Bunge, Wand and Weber ontology that leads to enterprise ontology will be used for these healthcare organisations. All ontology experts agree that there is no single correct ontology design methodology and they make no attempt to introduce one. Besides the various ontological theories, they all agree that the first step of ontology methodology is to determine the domain and the scope of the ontology. The methodology DEMO used in this study is based on enterprise ontology (Wand, Weber, 1995).

THE ONTOLOGY MODEL OF A PATIENT ORIENTED PERFORMANCE FLOW

The starting point according to Dietz is the explicit terminology and synonyms (Dietz, Baris, 1999). An intensive research in various ontology libraries like the Stanford library with ontoligua and DAML ontology library as well as DMOZ libraries showed no results on this field of studies that resembles a patient oriented performance assessment system (Protégé, 2000).

Selected definitions for hospital, doctor, patient, event as well as many others are provided by OECD and are relevant to this study's aims and objectives. The definitions are subject to changes over time according to the European Health Organisation (OECD, 2002).

Initiating now the ontological model once the semiotic triangle (Bunge, 1977) and the ontological parallelogram (Dietz, Baris, 1999) are analysed, based on DEMO methodology, the following steps have to be followed:

1. The **Performa-Inforna-Forma** Analysis. In this step all available knowledge is divided to three sets. These knowledge sets of action are relevant to the human ability towards:
 - a. exposing a commitment and evoking a commitment (**performa**) representing **ontological action**,
 - b. expressing a thought or educing a thought (**inforna**) is representing **info logical action**,
 - c. Uttering information or perceiving information (**forma**) representing **data logical action**.
2. The Coordination-Actors-Production Analysis. The **performa** items are divided to C-acts/results that denote actor responsibility and P-acts/results that denote actor competence.
3. The Transaction Pattern Synthesis. In this step there is a clustering of the identified c-acts/facts and p acts/results forming transactions with specific results. As the previous steps introduced C-acts/results and P-acts/results a complete transaction pattern (TRT) is possible.
4. The Result Structure Analysis. According to the composition axiom every actor's transaction has a result to the environment. The results of

these transactions will be viewed in this step as components of the end result.

5. The Construction Synthesis. In this step the Actor Transaction Diagram (ATD) is produced as each actor's role is identified.
6. The Organisation synthesis. Finally all of the above actors and their transactions are linked to the environment. The creation of a detailed ATD is the last step of the interaction model that is the most compact model of an enterprise.

The domain or universe of discourse of the ontological model is the patient flow. Thus, according to Wolstenholme's patient flow analysis, we have the world of elective patients and their flow through the healthcare system. Elective patients are considered those that are in the position to decide for their treatment process. Non elective patients are those that due to an emergency situation are not able to decide for their treatment process and as a result are unable to proceed with autonomy (Wolstenholme, E. F. 1999). A state of such a world can be conceived as a set of elementary facts which this world includes, such as the fact of the specific patient type or hospital policy or general practitioner's policy for this particular patient (Sure, Tempich and Vrandecic, 2006).

As briefly explained an ontological model links through the semiotic triangle the definitions of sign, object and concept. A sign is used as a representation of something else in the semiotic triangle (Figure 1). For example the "Patient Oriented healthcare" etiquette that is used in this study represents the type of healthcare that an object that is an identifiable individual thing like the elective patient receives in a healthcare system. So the concept of a patient oriented service is a subjective individual parameter, unless it possesses properties of classification based on objective measures. Although it still is by definition an abstract concept.

*Thus the patient oriented healthcare sign **relates** to a patient flow concept and should **denote** objective measurements in order for this concept to be **referred** as a patient oriented patient flow.*

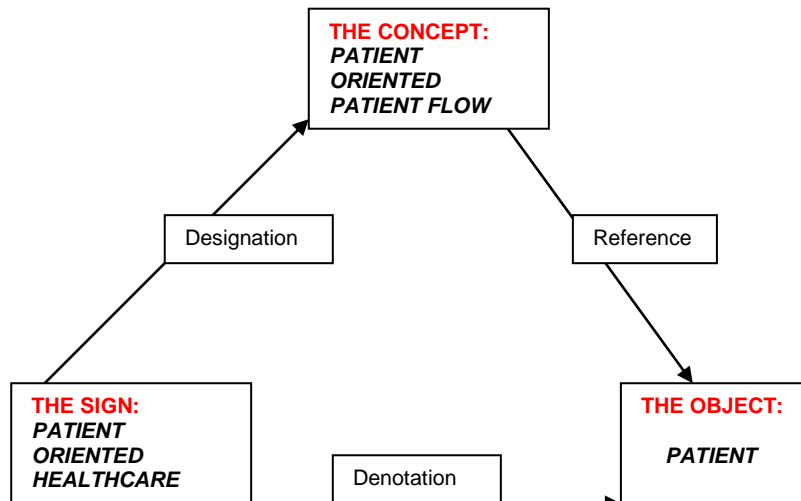

Figure1: The Patient Oriented Semiotic Triangle

Hence, the sign or symbol or mark of patient oriented healthcare is a physical signs that designates the concept of the patient oriented patient flow. Patient oriented patient flow refers to patient, to all types of patients depicted in the ontology parallelogram (cardiac patients, orthopaedic patients, etc...). So the designation and the reference denote the object patient. Without this denotation of the patient the patient oriented healthcare is meaningless.

Now all types of patients are extended to the class of elective patients that includes both privately or publicly treated patients through a healthcare system, and has a specific population of patients that enter the patient oriented patient flow at any given time. Thus the following ontological parallelogram is formed:

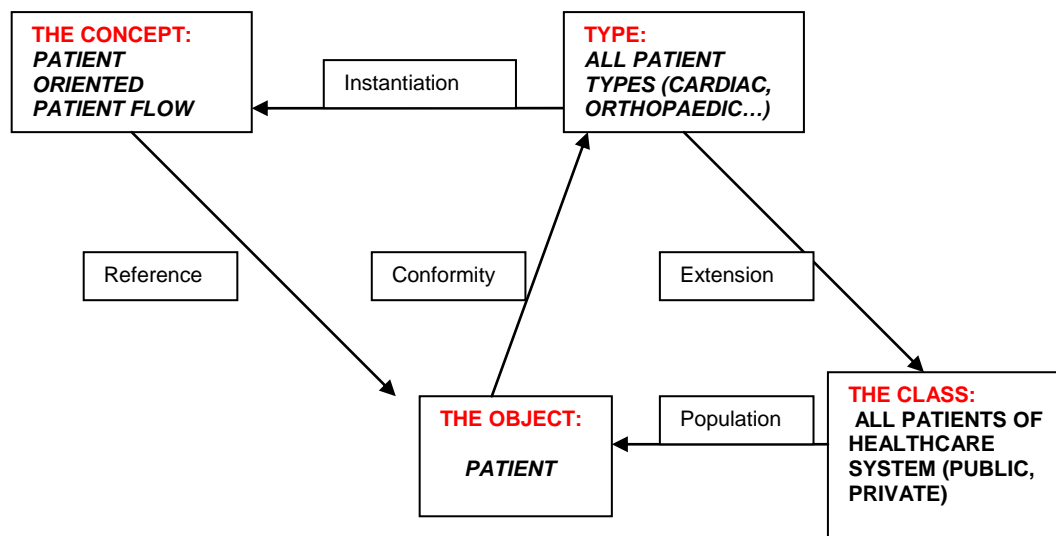

Figure 2: The Patient Oriented Ontology Parallelogram

The above parallelogram completes the factual knowledge of the ontology and the state model of this theory.

Continuing, there are three distinct human abilities, mentioned above, playing a role in the operation of actors defined as *performa*, *informa*, *forma*.

An actor, in order to perform these distinct human abilities, needs a certain level of support from a specific organisational level where his or her actions belong. (See relevant Figure 3).

The organisation is a heterogeneous system that involves different organisational levels, one in support of the other. Each layer supports the one above with the **ontological** level on the top. The first level that is the organisational base is the **data logical** level or the **D - Organisation**. It focuses primarily on the organisation's infrastructure, so it is mostly hardware oriented assisting the analogous actor's *forma* performance. At this level the organisation must also ensure that the necessary tangible assets are in existence for the operation of the next organisational level.

The next organisational level is the **info logical level** or the **I-organisation**. The **info logical** level is the level where the support of the first level is in order. The

necessary management of the information occurs at this level assisting the relevant actor's **informa** performance. At this level the organisation must ensure the necessary information flow for the operation of the next organisational level.

Finally the top organisational level is the **ontological** level where this study is focusing. At the **ontological** level or **B-organisational** level the actors of the system perform certain **performa** actions that fulfil transactions that are leading to specific results. The **B-organisation** requires a mix of services to be measured for the patient that is the centre of this system.

For these results the **info logical** or **I-organisational** level must be of support for the necessary knowledge to occur for the completion of these transactions. An active ontology blackboard system as well as other systems like the HL-7 could support interoperability at this level. Applications like the KAON server (<http://kaon.semanticweb.org/server>) could provide support at **D-organisational** level (Lepouras, et al., 2005). The **info logical** level as well as the **data logical** one that are necessary for the performance measures at **ontological** level are beyond the scope of this study.

The following triangular figure exhibits this philosophy:

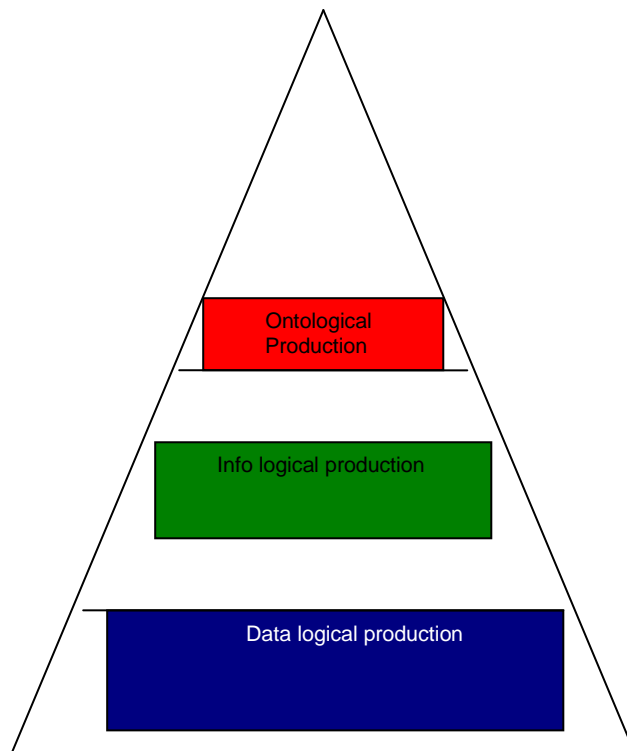

Figure 3: The Levels of the Organisation Theorem (Wand, Weber, 1995).

Based on Wolstenholme's patient flow, the human abilities distinction axiom and the organisational theorem, a **performa**, **informa**, **forma** analysis will follow.

1. Performa-Informa-Forma Analysis

The elective patient flow starts when the individual enters the healthcare system as patient. Patients **announce themselves** at the GP secretary. The GP **reads information** from **the patient record** through the **National Healthcare System central spine**. The GP **interpreting the patient's record (EPR)** **performs the examination**. When the GP **announces the examination results** both GP and patient **scan the proposed patient oriented performance ratios** for certain treatment routes to follow. Irrelevant of the route, the GP has to **inform the elective patient about the potential routes that he could choose advising on the proposed patient oriented performance ratios**.

The potential patient flow routes relevant to these performance ratios are the following:

- Condition advice with medication reference.
- Minor GP surgery.
- Reference for further treatment at secondary level.
- No further treatment. Patient exits system. Completes a patient report evaluating performance appraisal evaluation. The patient delivers the report to the healthcare organisation (HCO) from where he/she exits system.

All routes are available on the system's list. The doctor informs and interprets these performance ratios measuring budget cost figures and patient treatment horizon and success rates. The informed elective patient now has to fill out a form together with the GP for the decision taken regarding the optimal treatment route.

The patient enters the hospital and is informed for resources availability. If the patient is informed that there is not any resource availability on the hospitals records the patient has to wait or leave. If the patient is informed from the hospital's records that there is availability then the patient follows a treatment process. The patient is monitored, diagnosed for the right treatment or surgery, prepared for surgery and finally monitored again after treatment or surgery.

If patient still is not healthy enters to rehabilitation at third level until he is treated by clinicians or else exits (mortality issue or healthy issue) the system. Patient completes a report evaluating performance appraisal evaluation.

The patient delivers the report to the HCO from where the patient exits the system. Information is available at all levels of healthcare.

The above examination process performed at primary level could also be available for emergencies at secondary level for non elective patients with the

patient's family participation. Such flow is outside the patient oriented domain of this study as the patient is unable to proceed with autonomy.

2. The Coordination-Actors-Production Analysis

The coordination-actors-production analysis has to be performed based on DEMO methodology. In this stage the actors which have roles and authority are defined by “[“]” in text or in diagram by square. The production requires competence of the actor and is defined by “<” “>” or in diagram by a diamond. Finally the coordination world that implies responsibility is defined by “(“)” or in a diagram by a cycle.

[Patients] (Announce) themselves at the [GP] [secretary]. The [GP] reads information from the [Patient] record through the NHS central spine. The [GP] interprets the [Patient's] record (EPR) and <performs> the examination. When the [GP] (announces) the examination results, both [GP] and [Patient] scan the proposed [Patient] oriented performance ratios for certain treatment routes to follow. Irrelevant of the route, the [GP] has to inform the elective [Patient] about the potential routes that [he] could choose advising on the proposed [Patient] oriented performance ratios.

The potential [Patient] flow routes relevant to these performance ratios are the following:

- Condition advice with medication reference.
- Minor [GP] <surgery>.
- Reference for further <treatment> at secondary level.
- No further <treatment>. [Patient] <Exits> system. <Completes> a patient report <evaluating> performance appraisal evaluation. The [Patient] <delivers> the report to the HCO from where he <exits> system.

All routes are available on the system's list. The [GP] informs and interprets these performance ratios <measuring> budget cost figures and patient

treatment horizon and success rates. The informed elective [Patient] now has to fill out a form together with the [GP] for <deciding> regarding the optimal treatment route.

The [Patient] <enters> the hospital and is informed for resources availability. If the [Patient] is informed that there is not any resource availability on the hospital's records the [Patient] has to <wait> or <leave>. If the [Patient] is informed from the hospital's records by a [clinician] that there is availability then the [Patient] <follows> a treatment process. The [Patient] is <monitored>, <diagnosed> for the right <treatment> or <surgery>, >prepared> for <surgery> and finally <monitored> again after <treatment> or <surgery> by the [clinician] and the [doctors].

If a [Patient] still is not healthy <enters> to rehabilitation at third level until he is <treated> by [clinicians] or else <exits> (mortality issue or healthy issue) the system. The [Patient] <completes> a report <evaluating> performance appraisal evaluation. The [Patient] <delivers> the report to the HCO from where the [Patient] <exits> the system. Information is available at all levels of healthcare.

The transaction pattern synthesis that follows will indicate the responsibility acts and facts of the model that indicates the actor responsible for each act.

3. The Transaction Pattern Synthesis

The below diagram gives an example of the patient doctor transaction and thus analyses the basic transaction pattern. A transaction has three phases:

1. The order phase (O-Phase). In this phase the initiator that initiates the transaction cooperate with the executor that is the actor that delivers the transaction in order to reach an agreement for the transaction result. If the result is agreed then a production fact is in existence. In the following diagram the white box represents a C-act type. A C-act type is a promise of a transaction that has specific time and result (C-fact) and is initiated by an actor that has the authority to do so, in this example the initiator is the patient and the executor is the doctor.

2. The Execution Phase (E-phase). This phase refers to the production act and fact. A grey box is a P-act type and states that a promise has been made from an actor that has the authority (patient). The grey diamond is a P-fact type that signifies that a promise has the specific result required from the patient and is implemented from an actor that has the competence (doctor) to do so.
3. The result phase (R-phase). This phase refers to the result of the transaction and the result is relevant to the type of transaction that takes place. This relationship is analysed in the next step of this methodology.

The following diagram analyses the above parameters and shows that for every transaction that is accumulated there is a specific actor cycle, subject to measurement's framework, for a result to occur.

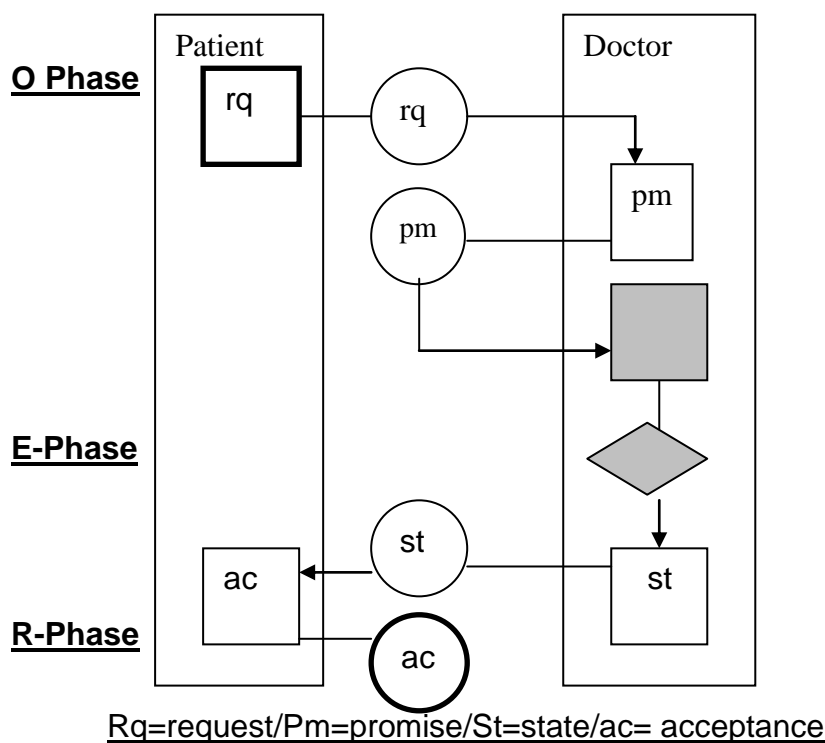

Figure 4: The Basic Transaction Pattern

4. The Result Structure Analysis

The result of this step is the accumulation of the Transaction Result Table (TRT). These transactions are embedded in the previous ontological coloured reports of the patient flow process. An ontological system is defined as a system that keeps interaction bonds like composition, environment, composition products and structure together (Bunge, 1977).

The objective here is to develop a conceptual model in order to further understand the current problems. For example a performance measurement system will be conceptualised as a model of patient oriented transactions. Mapping the system process will help assessing the necessary data currently supplied for patient satisfaction (Matthew D., Clarke L, 2004). A concrete visual is a model of a conceptual system that it is called system's implementation.

The Transaction Result Table (TRT) that follows will assist in completing the above ontological model properties:

TRANSACTION TYPE

RESULT TYPE

T1 Patient oriented inflow	R1 Initiation of a patient relation management
T2 E P R analysis	R2 Control of patient record
T3 Doctor's referral	R3 Ratio performance quality communication
T4 Hospital inflow	R4 Safe treatment preparation
T5 Rehabilitation referral /Hospital outflow	R5 Outpatient rehabilitation and chronic care program
T6 Rehabilitation monitoring	R6 Verification of rehabilitation process

T7 Patient oriented outflow	R7 Patient satisfaction based on continuous patient relation management
T8 Patient Record management	R8 Storage, indexing, retrieval of patient records
T9 Retrieve information from NHS Ontological Data Base	R9 Interpret information based on expertise
T10 Patient Examination	R10 Diagnosis of the patient's problem
T11 Patient oriented measurements analysis for specific problem	R11 Patient value added treatment proposal
T12 Initiation of patient's treatment cycle	R12 Doctor's medical quality counselling
T13 Electronic project management treatment	R13 Electronic verification of treatment process and medical operations
T14 Evaluation of the treatment and rehabilitation cycle based on proposed appraisal measures	R14 Patient value added service. Cure and prevention plan
T15 Doctor's expert opinion	R15 Patient quality communication
T16 Laboratory tests	R16 Laboratory quality results
T17 Clinical tests	R17 Clinical quality results
T18 Treatment performance	R18 Patient's safe medical operations or treatment initiation
T19 Treatment narration of methodology	R19 Patient's awareness of the full treatment cycle and medical operations

Table 2: The TRT of the Elective Patient Flow

Lists of depended transactions or results associated with the above transactions are identified in the following result structure analysis.

Every transaction has to create a specific result which is exhibited above.
The results' relationships are presented in the next figure:

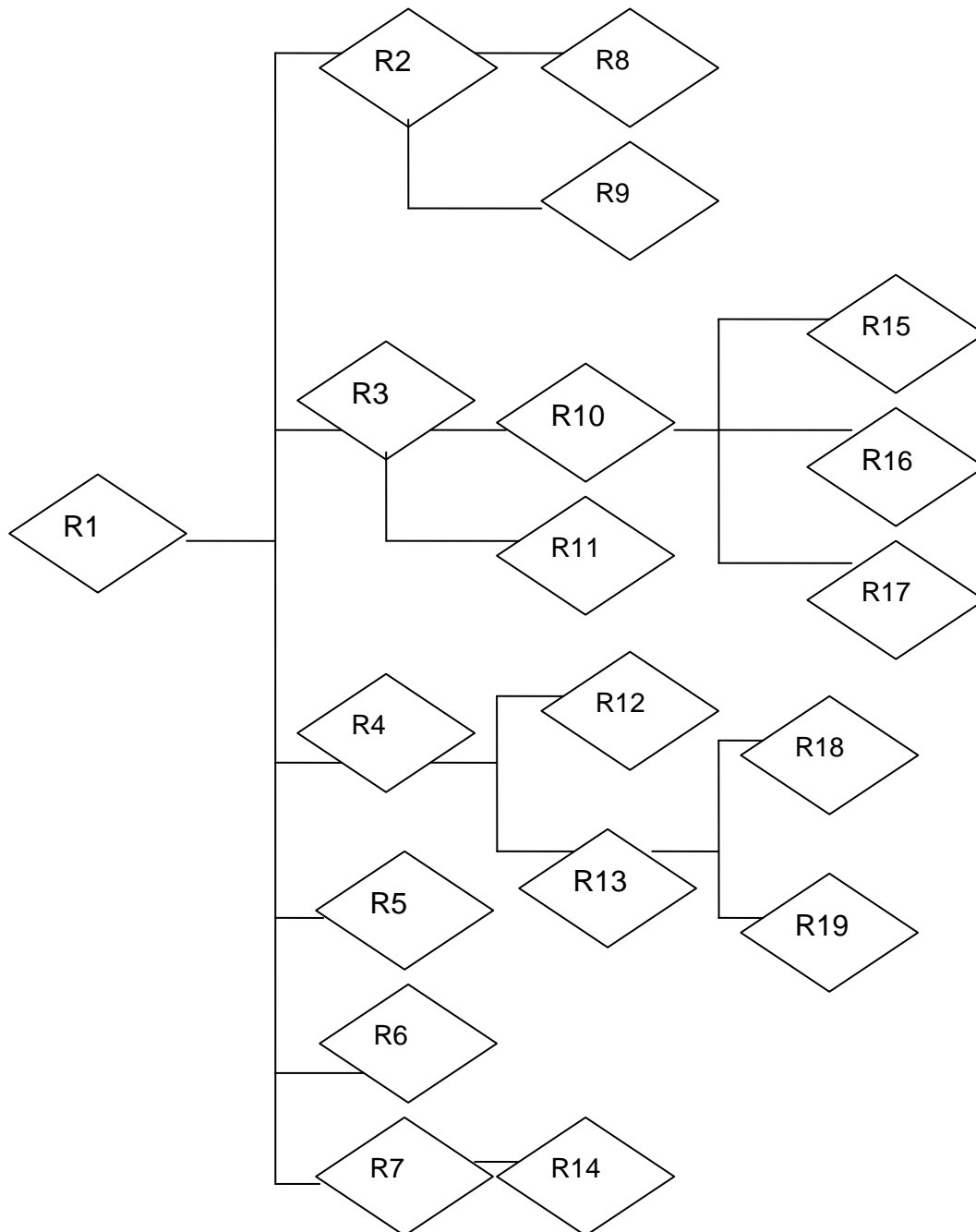

Figure 6: The Result Structure Chart of the Patient Oriented Flow

5. The Construction Synthesis

In this step the actual analysis presented in one simple transaction of the basic transaction pattern has to be extended for all transactions governing the patient flow analysis (see Figure 4). This pattern due to the limitations of this study could be skipped as it does not alter the result that is the construction model that is the most solid ontological model accumulated by the enterprise ontology.

6. The Organisation Synthesis

At this final step a solid decision has to be taken as to what part of the construction will be taken by the internal environment (HCO) and which part will be taken by the external environment that is the NHS of the patient flow ontological model. Actors in to this system have two types of roles elementary and composite. The elementary roles contain no specific interaction with the other actors relevant to the result produced by the transaction initiated. Most of the times although actor roles are composite and they follow the CRISP model that is:

- ✦ C: a set of C-facta, called coordination. For C the actor has an agenda of actions (example: treatment) that have to be satisfied for a transaction to be completed.
- ✦ R: a set of action rules, called rule based. This rule defines that the product of C actions and the set of S (patient data) declare the domain of R.
- ✦ I: a set of intentions, called intension base. For I there is a set of intensions necessary for the c-facta (results of the responsibility world, C-world) that are taking place within the hospital or the Gp office or any HCO.
- ✦ S: a set of facta and stata, called the state base. The state base contains all instances (patient data) that have to be known in order for an actor that has the responsibility (P-world) to perform.

- ✦ P: a set of P facta, called the production base. Is the sum off all transaction results that the actor (example: doctor) produced due to the responsibility that has.

There are also two more types of lines and a boundary. The line with an arrow at the end signifies that the actor is the executor of the transaction. On the contrary a straight line with no arrow indicated an actor that is the initiator of an action. The frames around the actors signify the organisations like GP office or hospital and the diamonds inside the cycles the transactions performed. The numbering of the transactions signifies that the first seven transactions are core transactions and encompass the second line of transactions from number eight to nineteen (Figure 6).

The large doted frame denotes the national healthcare system of a country and the inside solid frames the according healthcare institutions.

The following Actor Transaction Diagram (ATD) exhibits the complete detailed ATD structure of such patient oriented healthcare flow:

PATIENT ORIENTED PERFORMANCE MEASURES

All the measures that are going to be developed are ontology driven and will measure the results of the specific transactions occurred in this ontological model. The measures, by definition, are necessary parameters for an efficient, effective and equal patient flow. For every transaction and result the model uses the assistance of specific measuring applications and methods which could be of value added for the patient and his flow. The framework which is going to be used for tracking those measurements will be based on the balanced score card methodology (Kaplan and Norton 1992). This performance assessment methodology is the indicated one as it could adapt to the above model.

Following is a selective transaction-result presentation and their association with the patient oriented performance appraisal framework. Transactions like the patient oriented inflow (T1) that initiates the patient relation management (R1) and the last core transaction of patient outflow (T7) that results to patient satisfaction based on continuous patient relation (R7) require an active on line service that could supply measures and data from the rest of the transactions. It is very important element for a patient oriented measure to capture the complete healing cycle rather than the transaction based treatment process. The healing cycle could take years and that is why the above two transactions and results are required.

Based on this model TRT table the patient oriented inflow (T1) must result to the initiation of a patient relation management (R1). A series of other transactions with specific results follow this transaction result type (T1-R1). Thus the EPR analysis should (T2) result to the control of patient record (R2).

A knowledge management mechanism known as formal concept analysis could assist in measuring this transaction, as well as others like the patient record management (T8) and the patient's examination (T10). This mechanism is compatible for measuring the ontological patient oriented model

presented, as it is multi disciplinary and could assist every instance of the ontological parallelogram that is the patient type.

CONCLUSION AND DISCUSSION

The patient flow ontological domain has to be captured in order to measure in a patient oriented way the results produced. Implementing the balanced scorecard method, analysing the transaction pattern figure, an exact measuring card could occur that will fulfil the semiotic triangle as it designates a patient oriented flow concept. The necessary requirements for the patient oriented performance measurement framework are the following:

1. An Ontology Based Structure of an Elective Patient Oriented Performance Flow. This is the parameter that this study analysed, based on enterprise ontology, and is of paramount importance to clearly define the concept of a patient oriented flow.
2. A performance measures assessment framework. A framework should be developed, based on the balanced scorecard method, with measures that will focus on specific parameters of the treatment cycle rather than the healing process.
3. Measures that asses the patient oriented concept as presented in this study focusing on effectiveness, efficiency and patient equality.
4. Infrastructure, as presented according to the organisation theorem of enterprise ontology, that could support the ontological level of this patient oriented model.
5. Electronic Patient Record infrastructure.

The results of this study will contribute to a precise measurement framework that will focus on patient value added services. The ontology presented in this study will assist this framework, which is under development, to be encompassed to all relevant fields of study as a truly patient oriented assessment instrument.

REFERENCES

1. Blobel, B., Gell, G., Hindlebrand, C., Engelbrecht, R. (2004).
“Contribution of medical Informatics to Health” Integrated clinical Data and Knowledge to Support Primary, Secondary, Tertiary home Care.”
Proceedings of European federation for the medical Informatics and Special Topics Conference 2004. Munich, Germany.
2. Bunge, M.A. (1977). *Treatise on Basic Philosophy: A world of Systems*, D. Reidel Publishing Company, Dordrecht, The Netherlands.
3. Cochrane A. (1972). *Effectiveness and efficiency: Random reflections on health services*. Nuffield Provincial Hospitals Trust, London.
4. Dau F., Klinger, J. (2003). *From Formal Concept Analysis to Contextual logic*. Proceedings of International Conference on Formal Concept Analysis (*ICFCA*) 2003, Berlin, Germany
5. Dietz, J. L. G., Barjis, J. (1999). *Supporting the DEMO Methodology with a Business Oriented Petri Net*. The proceedings of the fourth CAISE / IFIP8.1 International Workshop on Evaluation of Modeling Methods in Systems Analysis and Design (EMMSAD'99), Heidelberg, Germany
6. Eipstein, A.M. (1998). “Rolling down the runway”, *Journal of the American Medical Association*, Vol. 28, pp 17-22.
7. Kaplan, R., Norton, D. (1996). *The Balanced Scorecard*, Boston: Harvard Business Press
8. Harris, M.R., Graves, J.R., Herrick, L.M., Elkin, P.L., Chute, C.G. (2000). “The Content Coverage and Organisational Structure of Terminologies: The Example of Postoperative Pain”, *Proceedings of the AMIA Annual Symposium*, pp 335-339.
9. Lowell, V. (2004). “Actions in Healthcare Organisations: An Ontological Analysis”, *Proceedings of Medinfo*, San Francisco, September 2004 pp 1-5.
10. NHS Executive 1998. “An information strategy for modern NHS 1998-2005: A national strategy for local implementation”. *National Healthcare System Report*, pp70-78

11. Ovretveit, J. (2001). "Quality Evaluation and Indicator Comparison in HealthCare", *International Journal of Health Planning and Management*, Vol. 16, pp 229-24.
12. OECD (2002). "Measuring up: Improving health system performance in OECD system performance in OECD countries", Ottawa, Paris, November 2001, Conference Proceedings Section A-4, pp 5-7.
13. Papagiannis, F., Danas, K., Roudsari, A. (2005). "The Health Care Patient Flow Process", *International Symposium on Health Information Management Research*, Conference Proceedings, Thessalonica, pp 9-11.
14. Bontas P., Tempich C. (2005). How much Does it Cost? Applying ONTOCOM to DILIGENT. Technical Report TR-B-05-20, Free university of Berlin
15. Protégé (2000). The protégé Project. Electronic Document available at: <http://protege.stanford.edu>
16. Rosemann, M., Wyssusek, B. (2005). "Enhancing the Expressiveness of the Bunge-Wand-Weber Ontology, proceedings of the Eleventh Americas Conference on Information systems, Omaha, NE, USA, August 11th- 14th 2005
17. Stavert, D., Boon, J.B. (2003). "Leadership in Health services", *Health Affairs*, Vol. 19, pp 124-125.
18. Tountas, Y., Economou, N. (2007). "Health services and health systems Evaluation", *Archives of Hellenic medicine*, Vol 24, pp 7-21.
19. Wand, Y., Weber, R. (1995), "On the deep structure of information systems", *Information Systems Journal*, Vol 5, pp-203-223
20. Wolstenholme, E. F. (1999). "A Pass and Flow Perspective of UK Health Services: Exploring the Case for New Intermediate Care Incentives", *System Dynamics Review*, Vol. 15, pp 253-27
21. Sure, Y., Tempich C., Vrandecic, D. (2006). *Ontology Engineering Methodologies in Semantic Web Technologies: Trends and Research in Ontology-based Systems*. Wiley, UK

