

**Title:** Deception has no Acute or Residual Effect on Cycling Time Trial Performance but Negatively Effects Perceptual Responses

**Authors:** Hollie S Jones<sup>1</sup>, Emily L Williams<sup>2</sup>, David C Marchant<sup>3</sup>, S Andy Sparks<sup>3</sup>, Craig A Bridge<sup>3</sup>, Adrian W Midgley<sup>3</sup>, and Lars R Mc Naughton<sup>3</sup>

**Affiliation:** <sup>1</sup>Centre for Sport and Exercise Sciences, University of Leeds

<sup>2</sup>School of Sport, Leeds Beckett University

<sup>3</sup>Department of Sport and Physical Activity, Edge Hill University

**Corresponding author:** Dr Hollie Jones, [h.jones2@leeds.ac.uk](mailto:h.jones2@leeds.ac.uk)

**Word count:** 3255

**Abstract word count:** 227

**Tables:** 1

**Figures:** 2

## **Abstract**

**Objectives:** Feedback deception is used to explore the importance of expectations on pacing strategy and performance in self-paced exercise. The deception of feedback from a previous performance explores the importance of experience knowledge on exercise behaviour. This study aimed to explore the acute and residual effects of the deception of previous performance speed on perceptual responses and performance in cycling time trials.

**Design:** A parallel-group design.

**Method:** Twenty cyclists were assigned to a control or deception group and performed 16.1 km time trials. Following a ride-alone baseline time trial (FBL), participants performed against a virtual avatar representing their FBL performance (PACER), then completed a subsequent ride-alone time trial (SUB). The avatar in the deception group, however, was unknowingly set 2% faster than their FBL.

**Results:** Both groups performed faster in PACER than FBL and SUB ( $p < 0.05$ ), but SUB was not significantly different to FBL. Affect was more negative and Ratings of Perceived Exertion (RPE) were higher in PACER than FBL in the deception group ( $p < 0.05$ ).

**Conclusions:** The presence of a visual pacer acutely facilitated time trial performance, but deceptive feedback had no additional effect on performance. The deception group did however experience more negative affect and higher RPE in PACER, whereas these responses were absent in the control group. The performance improvement was not sustained in SUB, suggesting no residual performance effects occurred.

**Key words:** Visual feedback; expectations; affect; perceived exertion; pacing strategy

## Introduction

Feedback deception has been used as a non-invasive, practical method by which athletes' self-beliefs and expectations of their performance can be manipulated.<sup>1,2</sup> The intent is to explore how athletic performance may be optimised through the access of reserve capacities. A recent application of decision-making theories to self-paced exercise has drawn attention to the significance of expectations (relating to performance, environmental and/or perceptual information).<sup>3,4</sup> Therefore, by manipulating the performance feedback that athletes receive, the importance of these expectations can be examined.<sup>5</sup>

Previous deception studies have demonstrated that pacing strategy and performance are largely unaffected by the provision of incorrect performance feedback during self-paced cycling time trials (TT).<sup>6,7</sup> As feedback is most influential when it is attended to and evaluated in respect to salient self-goals,<sup>8</sup> the type of feedback manipulated may have limited the effectiveness of the deceptive interventions. This is further supported by the suggestion that feedback must be mediated by previous experience to influence performance.<sup>9</sup> Pacing strategies are said to be based on a pacing 'schema' which is created through prior experience and recalled for future tasks.<sup>10</sup> During exercise, the current performance is evaluated against this stored schema to ensure that an optimal pacing strategy is adopted.<sup>11</sup> Feedback deception is employed in order to create a mismatch in this evaluation and trigger a decision to change behaviour, thus deviating from the learned schema.

One study demonstrated that cyclists improved performance when provided with visual feedback of their fastest previous 4 km TT.<sup>12</sup> Moreover, when this feedback was manipulated to represent 102% of the athletes' fastest baseline, performance was improved further; attributed to the accessing of a reserve capacity.<sup>12</sup> Alternatively, this is also supported by motivational theories stating that the presence of competition, in this case a faster self, can improve performance.<sup>13</sup>

Whilst some studies have shown that performance is influenced in a trial in which the deception is employed, i.e. an acute response, others have investigated the effects of deception on subsequent performance, i.e. a residual response.<sup>9,14</sup> If deceptive feedback is employed to manipulate the learned schema, then it is of interest to explore whether the alteration to this schema is retained in future exercise bouts. Micklewright et al.<sup>9</sup> found that an intensity deception elicited a significantly faster, but unsustainable, start in a subsequent 20 km TT. Using a distance feedback manipulation, another study found performance improvements in a subsequent TT which may have derived from enhanced self-efficacy and motivation following the deception exposure.<sup>14</sup> Research has yet to explore whether a deceptive intervention relating to a previous performance has a residual effect on self-paced exercise, despite an implication of a better understanding of the role of prior experience in the regulation of pace.

In addition to an influence on pacing strategy, previous experience might also be an important determinant of subsequent perceptual experiences during exercise. For example, the valence of emotions are the product of emotional responses experienced during previous performance accomplishments<sup>15</sup> and are pertinent to perceptions of self-efficacy<sup>16</sup> and future behaviour.<sup>17</sup> Furthermore, the experience of aversive situations is related to the development of perceptions of self-efficacy.<sup>2</sup> Despite many deception studies suggesting that these perceptual responses may be explicatory of altered pacing strategies and performance,<sup>18</sup> few demonstrate evidence to substantiate these proposals. In particular, the measurement of during-task self-efficacy is a novel construct seldom explored in pacing or deception research.

The aim of this study was to explore the acute and residual effects of the deception of previous performance speed on perceptual responses and performance in 16.1 km self-paced cycling TT. It was hypothesised that deception would facilitate performance both acutely and residually, but in the presence of more negative perceptual responses.

## Methods

Twenty trained male cyclists with 16.1 km TT race experience volunteered for the study. Participants provided prior written informed consent and the study was approved by the departmental research ethics committee. Match-paired, random allocation was used to assign participants to either a control (CON) or deception (DEC) group based on  $VO_{2peak}$  values and performance times achieved in TT1 (Table 1). Participants were classified as ‘trained’ according to  $VO_{2peak}$  and peak power output (PO) values.<sup>19</sup>

**Table 1** Mean (SD) descriptive data for the CON and DEC groups

	<b>CON group</b>	<b>DEC group</b>
	<b>(n = 10)</b>	<b>(n = 10)</b>
Age (y)	35.4 (7.8)	36.0 (7.6)
Height (cm)	179.7 (5.1)	177.4 (6.8)
Body mass (kg)	81.5 (9)	78.5 (12.1)
Absolute PPO (W)	368 (34)	370 (42)
Relative PPO (W/kg)	4.6 (0.4)	4.8 (0.5)
Relative $VO_{2peak}$ ( $mL \cdot kg \cdot min^{-1}$ )	57.6 (6.7)	58.7 (6.6)
Absolute $VO_{2peak}$ ( $L \cdot min^{-1}$ )	4.7 (0.6)	4.6 (0.6)
Cycling experience (y)	> 1	
Current training volume	> 5 hr or 100 $km \cdot wk^{-1}$	

**CON** = control; **DEC** = deception; **PPO** = peak power output;  **$VO_{2peak}$**  = maximal oxygen uptake

A 2 x 3 (group x trial) parallel-group design was adopted and participants visited the laboratory on five occasions, 2-7 days apart at the same time of day ( $\pm 2$  hr), and within a 3 week period. After the initial maximal incremental test, both groups completed four 16.1 km cycling TTs (Figure 1). A 16.1 km TT is the most common competitive road TT distance and therefore

enhanced the external validity of the findings. Testing was conducted following the refrainment from strenuous exercise and alcohol consumption in the preceding 24 hr and a two hour fast and caffeine abstinence. Participants were instructed to maintain normal training and dietary practices throughout the testing period and provided training and nutritional diaries on their first visit. Diaries were replicated in the 24 hr before each additional trial and between-trial conformity was checked. In the preceding two hours, fluid prescription comprised a minimum of 500 ml and water was consumed *ad libitum* during each trial. No significant differences were found in consumption between trials.

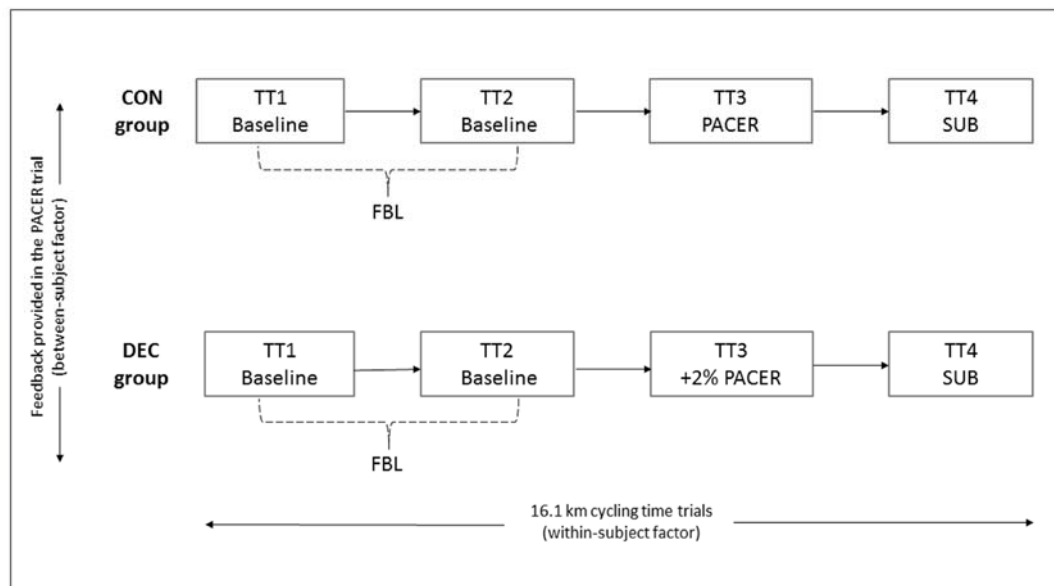

**Figure 1** Trial schematic of the research design for both CON and DEC groups

CON = control group; DEC = deception group; FBL = fastest baseline trial; PACER = pacer trial; SUB = subsequent trial; TT = time trial

On the first visit, height and body mass were recorded prior to a continuous incremental ramp test to maximal exertion on a cycle ergometer (Excalibur Sport, Lode, Groningen, The Netherlands) to determine  $VO_{2peak}$ . Following a 5 min warm-up at 100 W, initial workloads were determined using established guidelines<sup>20</sup> and 20 W increments were applied every minute

until the required PO could no longer be maintained. Breath-by-breath pulmonary ventilation and gas exchange data were recorded throughout the test (Oxycon Pro, Jaeger, GmbH, Hoechburg, Germany) to record oxygen consumption, which was normalised to pre-exercise body mass data. The  $VO_{2peak}$  was defined as the highest  $VO_2$  value recorded over a 20 s period. Heart rate (Polar Team System, Finland) was recorded continuously using a 5 s sampling rate and verbal encouragement was provided.

Both groups subsequently completed four self-paced 16.1 km TT on their own bicycles, using a calibrated electromagnetically-braked cycle ergometer (CompuTrainer Pro™, RacerMate, Seattle, USA); previously shown to be a reliable measure of PO.<sup>21</sup> A 0.6% coefficient of variation was found in our laboratory for between-trial variation in performance times (n = 31) and a 0.6% smallest worthwhile change in road TT performance has been previously reported.<sup>22</sup> The first two TTs (TT1, TT2) were used for familiarisation, but to prevent sub-maximal efforts being produced, participants were not informed of this. Ergometry software generated a flat, virtual course which was projected onto a 230 cm screen in front of the rider and which depicted the participants' speed profile as a synchronised graphical avatar. Time and PO were recorded at a rate of 34 Hz, but distance covered was the only variable displayed. Instructions were to complete each TT in the fastest time possible after a 10 minute warm-up cycling at 70% of  $HR_{max}$  and the drafting option in the software was disabled.

Each individual's fastest performance from TT1 and TT2 was classified as their 'fastest baseline' (FBL). In the third TT (PACER), the software represented each participant's FBL performance profile as a 'pacer' alongside their current performance; depicted as a dynamic and exact replication of the FBL speed profile. The pacer in the CON group was accurately set as their FBL performance. The DEC group, however, were informed that the pacer was their FBL performance, but it was actually set 2% faster than their FBL. The distance between the participants' avatar and the pacer was additionally displayed. A subsequent TT (SUB) was then performed, which replicated the FBL procedures with no pacer in either group (Figure 1).

Affect, self-efficacy and ratings of perceived exertion (RPE) were measured every 4 km and participants were fully briefed with the instructions for each scale's use. Affect was measured using the validated 11-point Feeling Scale ranging from +5 (pleasure) to -5 (displeasure).<sup>23</sup> Participants were informed that their responses should reflect the affective or emotional components of the exercise and not the physical sensations of effort or strain. Borg's<sup>24</sup> 6-20 scale was used to measure RPE and for task-specific self-efficacy, participants reported '*how confident are you to continue at your current pace for the remaining distance of the trial?*' on a percentage scale from 0% (*cannot do at all*) to 100% (*absolutely certain can do*).<sup>25</sup> This type of self-efficacy measurement, employed throughout the trial, was constructed to reflect the cyclists' beliefs concerning their pacing strategy selection and is a novel contribution to the field of pacing.

Heart rate was measured continuously and respiratory gas analysis recorded expired air every 4 km. Minute ventilation ( $V_E$ ), pulmonary oxygen uptake ( $VO_2$ ) and the respiratory exchange ratio (RER) were subsequently assessed. To allow normal drinking behaviour, a mouthpiece and nose clip were worn for 1 km every 4 km of distance covered (3.5-4.5, 7.5-8.5, 11.5-12.5 and 15.1-16.1 km). Fingertip capillary blood lactate (BLa; Lactate Pro, LT-1710, Arkray, Japan) was analysed prior to and immediately upon the completion of each trial.

Linear mixed modelling was used as the statistical approach for this study to account for dependency in the data, prevent listwise deletion, and to include random as well as fixed effects in order to improve the overall fit of the model. The modelling explored the effects of distance (4, 8, 12 and 16.1 km), trial (FBL, PACER, SUB) and group (CON, DEC) on all repeated-measures dependent variables; PO, affect, RPE, self-efficacy, heart rate,  $V_E$ ,  $VO_2$  and RER. Distance, trial and group were modelled as fixed effects and participant as a random effect. Distance was modelled as a continuous variable where linear or quadratic responses were evident, and otherwise modelled as a categorical variable where saturated means modelling was most appropriate. Various plausible covariance structures were assumed, with the structure that minimised the Hurvich and Tsai's criterion (AICC) value chosen for the final



fitted model. Performance times and mean pre- to post-trial BLA changes were analysed with fixed effects included for trial and group. Differences between dependent variables in TT1 and TT2 were analysed using paired t-tests. In the event of significant fixed main or interaction effects, post hoc comparisons with Sidak adjusted *P* values were used to identify significant differences between paired means. Two-tailed statistical significance was accepted as  $p < 0.05$  and analyses were conducted using IBM SPSS Statistics 22 (SPSS Inc., Chicago, IL). Descriptive sample statistics are reported as mean and standard deviation (SD).

## Results

Performance times for the CON group in FBL, PACER and SUB were 27:10 (2:08), 26:47 (1:55) and 26:55 (1:58), respectively. For the DEC group, performance times were 27:00 (1:31), 26:41 (1:13) and 26:56 (1:38). A main effect for trial demonstrated significant differences in performance times ( $F=4.8$ ;  $p=0.018$ ), with pairwise comparisons indicating that PACER was performed in a significantly faster time than FBL (mean difference (MD)=-0.35; 95% CI=-0.68, -0.02;  $p=0.039$ ). Performance time in SUB was not significantly different to FBL (MD=-0.15; 95% CI=-0.34, 0.34;  $p=0.13$ ) or PACER (MD=0.19; 95% CI=0.14, 0.5;  $p=0.37$ ), nor was there a significant group x trial difference ( $F=0.7$ ;  $p=0.50$ ).

PO was significantly different across distance ( $F=59.0$ ;  $p < 0.001$ ) and between trials ( $F=7.9$ ;  $p < 0.001$ ), but no trial or distance interactions were found for group ( $p > 0.71$ ) (Figure 2A). Significant effects for distance are not demonstrated in Figure 2 in order to retain clarity. Values were greater in PACER than both FBL (MD=7 W; 95% CI=3.83, 10.42;  $p < 0.001$ ) and SUB (MD=3 W; 95% CI=0.10, 6.81;  $p=0.042$ ), and SUB PO was greater than FBL (MD=4 W; 95% CI=0.38, 6.97;  $p=0.023$ ). Pacing strategies in each trial are indicative of a U-shaped profile. Significant main effects for speed were found for trial ( $F=5.4$ ;  $p=0.005$ ) and distance ( $F=27.1$ ;  $p < 0.001$ ), with speed being significantly faster in PACER than FBL (MD=0.4 km·hr<sup>-1</sup>; 95% CI=0.17, 0.61;  $p < 0.001$ ) and SUB (MD=0.3 km·hr<sup>-1</sup>; 95% CI=0.03, 0.48;  $p=0.023$ ).

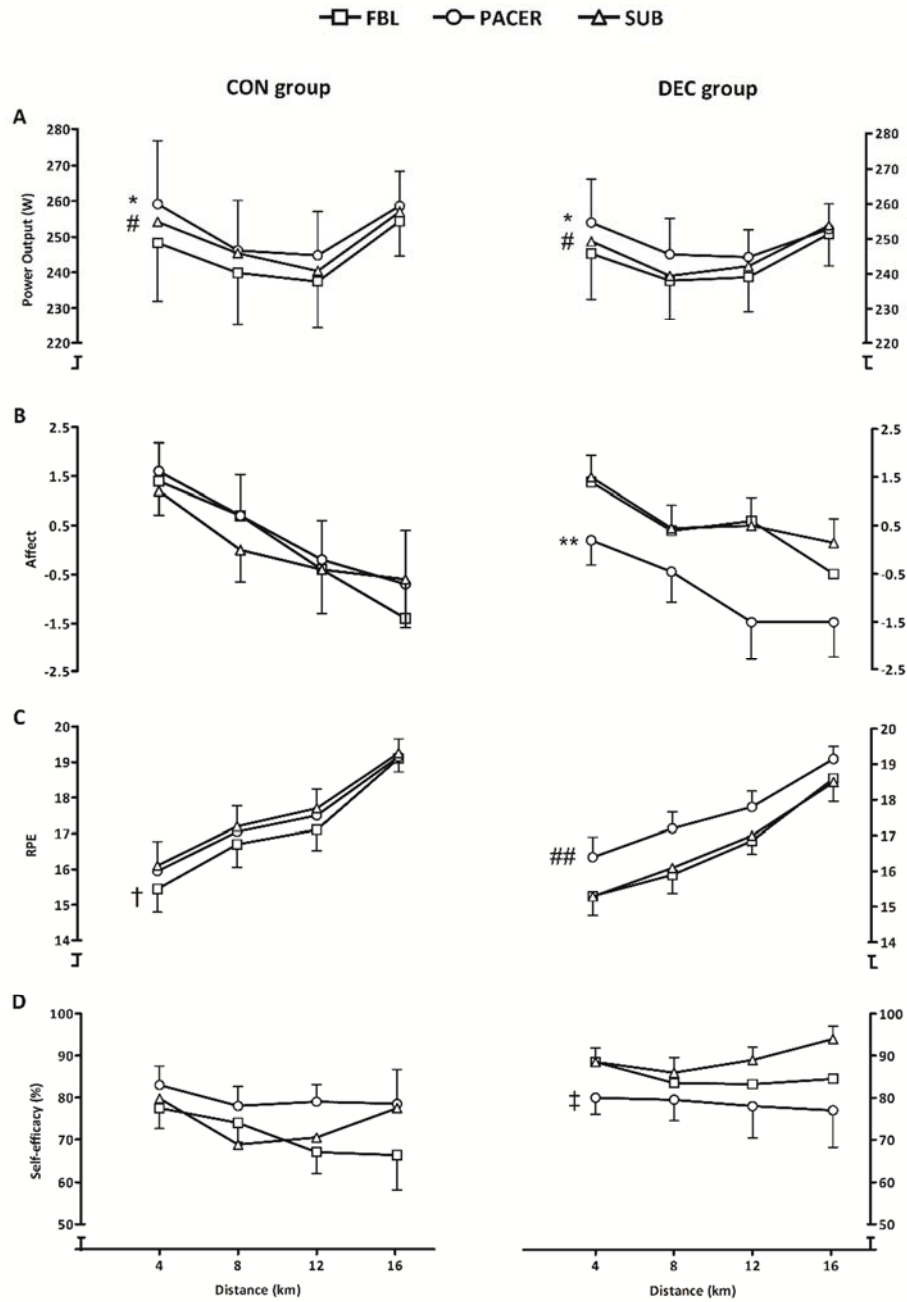

**Figure 2** Mean (SEM) power output, (A) affect (B), RPE (C) and self-efficacy (D) responses across distance in 16.1 km time trials for the CON and DEC groups

\* denotes significantly greater power output in PACER than FBL and SUB ( $P < 0.05$ ) # denotes significantly greater power output in PACER than FBL ( $P < 0.05$ ) \*\* denotes significantly lower affect in PACER than FBL and SUB ( $P < 0.001$ ) † denotes significantly lower RPE in FBL than SUB ( $P < 0.005$ ) ## denotes significantly higher RPE in PACER than FBL and SUB ( $P < 0.001$ ) ‡ denotes significantly lower self-efficacy in PACER than SUB ( $P < 0.005$ )

CON = control group; DEC = deception group; FBL = fastest baseline trial; PACER = pacer trial; SUB = subsequent trial; TT = time trial

Affect significantly decreased across distance ( $F=18.3$ ;  $p<0.001$ ) and differed between trials ( $F=4.1$ ;  $p=0.027$ ) (Figure 2B). A significant group x trial interaction ( $F=9.5$ ;  $p<0.001$ ) revealed that there was a greater attenuation in affect during PACER in the DEC group compared with the CON group. This decreased affect in the DEC group's PACER TT was significantly greater than in both FBL (MD=-1.3; 95% CI=-2.08, -0.50;  $p<0.001$ ) and SUB (MD=-1.5; 95% CI=-2.26, -0.67;  $p<0.001$ ). A significant trial x distance interaction ( $F=2.4$ ;  $p=0.04$ ) also revealed that at 8 km in PACER, affect was lower than FBL (MD=-1; 95% CI=-1.89, -0.01;  $p=0.046$ ).

RPE significantly increased across distance ( $F=6.6$ ;  $p=0.019$ ) and differed between trials ( $F=5.5$ ;  $p=0.005$ ) (Figure 2C). A group x trial interaction ( $F=3.4$ ;  $p=0.035$ ) showed that, in comparison to the CON group, RPE in the DEC group was significantly higher during PACER than FBL (MD=1.0; 95% CI=0.55, 1.40;  $p<0.001$ ) and SUB (MD=0.9; 95% CI=0.49, 1.34;  $p<0.001$ ). In the CON group, RPE was also significantly greater in SUB compared with FBL (MD=0.5; 95% CI=0.05, 0.90;  $p=0.022$ ).

Self-efficacy was significantly differently between trials only when mediated by group, indicated by a significant group x trial interaction ( $F=5.9$ ;  $p=0.006$ ) (Figure 2D). In the DEC group, self-efficacy was significantly lower in PACER than SUB (MD=-10.8%; 95% CI=-19.9, -1.6;  $p=0.017$ ).

Heart rate significantly increased across distance ( $F=68.3$ ;  $p<0.001$ ) and differed between trials ( $F=3.3$ ;  $p=0.049$ ), but the difference between PACER and SUB failed to reach significance (MD=2 beats·min<sup>-1</sup>; 95% CI=-0.05, 4.39;  $p=0.051$ ). Post hoc comparisons for a group x trial x distance interaction ( $F=3.3$ ;  $p=0.01$ ) revealed that heart rate in the DEC group was significantly higher in PACER than SUB at 8 km (MD=5 beats·min<sup>-1</sup>; 95% CI=0.36, 9.2;  $p=0.03$ ), 12 km (MD=5 beats·min<sup>-1</sup>; 95% CI=0.13, 8.96;  $p=0.042$ ) and 16.1 km (MD=5 beats·min<sup>-1</sup>; 95% CI=0.06, 8.89;  $p=0.046$ ). Significant distance main effects were found for  $V_E$ ,  $VO_2$  and RER ( $p<0.001$ ), but no group x trial interactions ( $p>0.30$ ). No significant differences were found in mean BLa changes for trial or group ( $p>0.34$ ).

Between-group analysis for TT1 and TT2 data revealed no significant differences for mean PO, affect, self-efficacy, heart rate, BLa or respiratory gases ( $p>0.05$ ). Mean RPE in the CON group was significantly higher in TT2 than TT1 ( $p=0.014$ ). Eight participants performed TT1 faster than TT2 and twelve participants performed TT2 faster than TT1.

## **Discussion**

The main findings demonstrate that the provision of visual previous performance feedback is beneficial to cycling TT performance in the trial in which it is presented. These performance improvements are observed regardless of the accuracy of the feedback, suggesting that deceptive feedback has no greater influence than accurate feedback. This refutes the study hypothesis which predicted that deceptive feedback would have a more substantial effect on performance. The perceptual responses accompanying this acute performance improvement, however, are more negative when this feedback is manipulated and therefore support the second study hypothesis. No residual performance effects were demonstrated in either feedback intervention as no significant differences in speed or performance time were found between FBL and SUB.

Previous research has shown that cycling TT performance can be improved with the provision of visual pacer feedback; attributed to increased motivation and a reduction in internal attentional focus.<sup>13,26,27</sup> As both groups similarly improved performance in PACER, this study further supports that cyclists are able to perform faster when riding with a virtual avatar, in comparison to a ride-alone trial.<sup>12,26,27</sup> Performance time reduced by 23 s (1.4%) in the CON group and 19 s (1.2%) in the DEC group from FBL to PACER which is greater than the smallest worthwhile change in TT performance and thus demonstrates practical importance.<sup>22</sup> Notably, no increases in heart rate, respiratory gases or BLa accompanied the faster PACER performances in comparison to FBL, refuting previous conclusions that the access of a physiological reserve was the responsible mechanism.<sup>12</sup> Instead, these improvements may be better explained by motivational theories such as an increase in potential motivation, enhancing the athletes' willingness to tolerate effort and enabling a faster performance.<sup>28,29</sup>

Despite performances not differing, the DEC group experienced more negative affect and higher RPE, whereas these perceptual responses were absent in the CON group (Figure 2). The presence of a virtual competitor has been shown to improve performance but in the absence of elevated perceptions of exertion, which was explained by a reduced internal attentional focus.<sup>26</sup> This holds true for the results demonstrated in the CON group, perhaps due to the accurate perception of the pacer's performance, therefore allowing its presence to be facilitative. In the DEC group, the mismatch created in the participants' perceptions may have superseded the facilitative effects of the pacer and resulted in more unfavourable perceptions of exertion and affective valence, supporting previous findings.<sup>12</sup> Furthermore, the CON group improved performance from FBL to PACER by 23 s (1.4%) so were therefore likely to be riding ahead the avatar and in a winning position during the TT. Alternatively, whilst the DEC group performed 19 s (1.2%) faster than their BL performance, the avatar was 2% faster so the cyclists were therefore more likely to be chasing and in a losing position. Consequently, a poorer positional status may have also prompted the more negative perceptual responses experienced by the DEC group. The relationship between perceptions and pacing therefore appears to be mediated by the provision of visual performance feedback and is subject to manipulation.

Interestingly, self-efficacy perceptions in PACER were unaltered in both groups. This suggests that the false beliefs experienced by the DEC group may have prevented a reduction in self-efficacy, which may have been expected due to previously established relationships between self-efficacy and both affect and RPE.<sup>2,25,30</sup> Consequently, this may instead support that the greater magnitude of the pacer presented to the DEC group and exposure to more challenging feedback prompted the unfavourable affective and exertional proclivities, not the infliction of false performance beliefs. This also resonates with the findings from Stone et al.,<sup>12</sup> whereby the faster performance demonstrated in the deception condition could be attributed to either the greater magnitude of the pacer or the experience of false beliefs. Further investigation is

thus warranted to explore the importance of each of these factors on both perceptual experiences and performance during self-paced exercise.

A further aim was to explore the residual effects of deception, however neither group were able to significantly improve performance from FBL to SUB, suggesting that accurate and deceptive feedback interventions produce immediate improvements, but these improvements are not likely to be manifested in future exercise bouts. The motivational facilitation altered the schema in PACER, but pace reverted back to the baseline profile once this aid had been removed in SUB. Consequently, this suggests that pacing schemas are not completely rigid in nature and acute variations can be manipulated, however the absence of an enduring change supports the overall robustness of this learned schema.<sup>10</sup> This contrasts a previous employment of a distance knowledge manipulation which reported residual performance improvements,<sup>14</sup> suggesting that the deceptive method adopted (i.e. the type of feedback manipulated) is an important factor influencing the efficacy of these interventions.

## **Conclusion**

This study demonstrates that the provision of visual previous performance feedback in 16.1 km cycling TTs improves performance regardless of the accuracy of this feedback. Deceptive feedback provided no additional effects on performance beyond that of accurate feedback, therefore the performance improvement may be explained by the motivational aid of the visual feedback. The experience of more negative perceptual responses during the exposure however, suggests that deception results in greater feelings of acute cognitive stress in the absence of changes in physiological strain. Furthermore, neither accurate nor deceptive feedback elicits a residual effect on performance in self-paced cycling TT. If feedback interventions are to be employed practically with athletes, it should be considered that deception which provides challenging feedback is likely to negatively influence perceptual responses, and performance improvements are unlikely to be retained in a subsequent exercise bout.

## **Practical implications**

- Visual feedback of a previous performance facilitates self-paced cycling time trial performance
- Performance is improved regardless of the accuracy of the feedback provided
- These performance improvements are not sustained in a subsequent time trial
- Deceptive feedback results in higher RPE and more negative affect

## **Acknowledgements**

No financial support was provided for this project.

## **References**

- 1 Stoate I, Wulf G, Lewthwaite R. Enhanced expectancies improve movement efficiency in runners. *J Sports Sci* 2012; 30:815-23.
- 2 Hutchinson JC, Sherman T, Martinovic N, et al. The effect of manipulated self-efficacy on perceived and sustained effort. *J Appl Sport Psych* 2008; 20:457–72.
- 3 Smits BLM, Pepping GJ, Hettinga FJ. Pacing and decision making in sport and exercise: The roles of perception and action in the regulation of exercise intensity. *Sports Med* 2014; 44:763–75.
- 4 Renfree A, Martin L, Micklewright D. Application of decision-making theory to the regulation of muscular work rate during self-paced competitive endurance activity. *Sports Med* 2013; 44:147-58.
- 5 Renfree A, West J, Corbett M, et al. Complex interplay between determinants of pacing and performance during 20-km cycle time trials. *Int J Sports Phys Perf* 2012; 7:121–9.

- 6 Beedie CJ, Lane AM, Wilson MG. A possible role for emotion and emotion regulation in physiological responses to false performance feedback in 10 mile laboratory cycling. *Appl Psychophys Biof* 2012; 30:1-9.
- 7 Nikolopoulos V, Arkinstall MJ, Hawley JA. Pacing strategy in simulated cycle time-trials is based on perceived rather than actual distance. *J Sci Med Sport* 2001; 4:212–9.
- 8 Szalma JL, Hancock PA, Dember WN, et al. Training for vigilance: The effect of knowledge of results format and dispositional optimism and pessimism on performance and stress. *British J Psych* 2006; 97:115–35.
- 9 Micklewright D, Papadopoulou E, Swart J, et al. Previous experience influences pacing during 20 km time trial cycling. *Br J Sports Med* 2010; 44:952–60.
- 10 Mauger AR, Jones AM, Williams CA. Influence of feedback and prior experience on pacing during a 4-km cycle time trial. *Med Sci Sports Exerc* 2009; 41:451–8.
- 11 Mauger AR, Jones AM, Williams CA. The effect of non-contingent and accurate performance feedback on pacing and time trial performance in 4-km track cycling. *Br J Sports Med* 2011; 45:225–9.
- 12 Stone MR, Thomas K, Wilkinson M, et al. Effects of deception on exercise performance: Implications for determinants of fatigue in humans. *Med Sci Sports Exerc* 2012; 44:534–41.
- 13 Wilmore JH. Influence of motivation on physical work capacity and performance. *J Appl Phys* 1968; 24:459-63.
- 14 Paterson S, Marino FE. Effect of deception of distance on prolonged cycling performance. *Perc Mot Skills* 2004; 98:1017–26.



- 15 Ekkekakis P, Hargreaves EA, Parfitt G. Invited Guest Editorial: Envisioning the next fifty years of research on the exercise–affect relationship. *Psych Sport Exerc* 2013; 14:751–8.
- 16 Bandura A. *Self-Efficacy: The Exercise of Control*. New York, NY, Freeman, 1997.
- 17 Baron B, Moullan F, Deruelle F, et al. The role of emotions on pacing strategies and performance in middle and long duration sport events. *Br J Sports Med*, 2011; 45:511–7.
- 18 Parry D, Chinnasamy C, Micklewright D. Optic flow influences perceived exertion during cycling. *J Sport Exerc Psych* 2012; 34:444–56.
- 19 De Pauw K, Roelands B, Cheung SS, et al. Guidelines to classify subject groups in sport-science research. *Int J Sports Phys Perf* 2013; 8:111-22.
- 20 Wooles A, Keen P, Palfreeman R. *Protocols used for the physiological testing of the Great Britain Cycling Team. Test Methods Manual* 2003.
- 21 Stone MR, Thomas K, Wilkinson M, et al. Consistency of perceptual and metabolic responses to a laboratory-based simulated 4,000-m cycling time trial. *Eur J Appl Phys* 2011; 111:1807–13.
- 22 Paton CD, Hopkins WG. Variation in performance of elite cyclists from race to race. *Eur J Sport Sci* 2006; 6:25–31.
- 23 Hardy CJ, Rejeski WJ. Not what, but how one feels: The measurement of affect during exercise. *J Sport Exerc Psych* 1989; 11:304–17.
- 24 Borg G. Perceived exertion as an indicator of somatic stress. *Scand J Rehab Med* 1970; 2:92–8.

- 25 Welch AS, Hulley A, Beauchamp M. Affect and self-efficacy responses during moderate-intensity exercise among low-active women: The effect of cognitive appraisal. *J Sport Exerc Psych* 2010; 32:154–75.
- 26 Williams EL, Jones HS, S Sparks A, et al. Competitor presence reduces internal attentional focus and improves 16.1 km cycling time trial performance. *J Sci Med Sport* 2014; 18:486-91.
- 27 Corbett J, Barwood MJ, Ouzounoglou A, et al. Influence of competition on performance and pacing during cycling exercise. *Med Sci Sports Exerc* 2012; 44:509–15.
- 28 Marcora S. Do we really need a central governor to explain brain regulation of exercise performance? *Eur J Appl Phys* 2008; 104:929–31.
- 29 Brehm JW, Self EA. The intensity of motivation. *Ann Rev Psych* 1989; 40:109-131.
- 30 McAuley E, Courneya KS. Self-efficacy relationships with affective and exertion responses to exercise. *J Appl Soc Psych* 1992; 22:312-26.