

*Report prepared for the Scottish Government by the  
Hill of Banchory Geothermal Energy Consortium*

# **Hill of Banchory Geothermal Energy Project Feasibility Study**

February 2016



Photo: courtesy Leys Estate

This report was funded by and prepared for the Scottish Government under the Geothermal Energy Challenge Fund, part of the Low Carbon Infrastructure Transition Programme (LCITP).

The report was written by the Hill of Banchory Geothermal Energy Consortium, an *ad hoc* team with the following membership:

Guy Milligan MEI, Director, Hill of Banchory ESCo Limited

George Wood FCIOB AaPS , Director, Jigsaw Energy

Professor Paul Younger FREng FICE, FGS, C.Eng., C.Geol., Rankine Chair of Engineering, Professor of Energy Engineering, University of Glasgow (contributor and editor)

Dr Michael Feliks, UK Operations Manager, Cluff Geothermal Ltd.

Dr Alistair McCay, Research Assistant, University of Glasgow

Dr Martin Gilliespie, British Geological Survey

Paul Steen CEng MICE, Associate Director, Ramboll Energy

Neil McBeth, Ramboll Energy

David Townsend, MD, Town Rock Energy

Phil Townsend, Chief Associate, Town Rock Energy

Professor Randell Stephenson, Chair in Geology & Petroleum Geology, University of Aberdeen

Dr Enrique Gomez-Rivas, Lecturer in Geology & Petroleum Geology, University of Aberdeen

### *Acknowledgements*

Elizabeth McAlpine provided highly effective administrative and organisational support to the consortium at our meetings in Banchory and Edinburgh.

The consortium members appreciate the support and assistance of Johann MacDougall, of the Scottish Government's Heat and Energy Efficiency Unit.

Professor Victor Mocanu of the University of Bucharest for loaning a gravity meter at cost and for help in the field.

Euan Johnston, graduated with an MSc in Geophysics from the University of Aberdeen in 2015, helped with the magnetic field acquisition as did Dr. Alistair McCay (University of Glasgow) and Goodluck Anudu, a PhD student in geophysics at the University of Aberdeen.

Dunecht and Leys Estate are thanked for their cooperation and interest.

## Contents

List of Tables.....	5
Executive Summary.....	6
1. Introduction.....	16
2. Background to Deep Geothermal Technology.....	19
3. The Hill of Banchory Biomass Heat Network.....	23
4. Geological Background.....	28
5. Provisional Borehole Design.....	42
6. Expanding the database: additional survey work on the Hill of Fare granite.....	45
6.1. Heat Production.....	45
6.2. Temperature Projections.....	47
6.3. Thermal Conductivity.....	50
6.4. Gravity and Magnetic Surveying.....	54
7. Assessment of Existing Baseline Data.....	61
8. Vision Statement – A Deep Geothermal Heat System at Hill of Banchory.....	67
9. The potential market for a geothermal well; heat demand in Banchory.....	71
10. The Economics of the Geothermal Well.....	78
11. Integrating the Upstream and Downstream Economic Models.....	85
12. Preliminary Heat Network Design Considerations.....	90
13. Risk Strategy.....	95
14. Deep Geothermal Regulation.....	99
15. Carbon Emissions Savings.....	101
16. Community Engagement.....	111
17. Conclusion and Recommendations.....	114
18. Strategic Implications of a Banchory Geothermal Project.....	115
19. Next Steps.....	116
References.....	118
Appendices.....	121
Appendix 1 – Thermal Conductivity Data.....	122
Appendix 2 – Network Heat Cost Model Input Variables.....	123
Appendix 3 – Risk Register.....	124
Appendix 4 – Heat Production Data for the Hill of Fare Granite.....	125

## List of Figures

Figure 1 – Location of granite bodies in north east Scotland and the heat flow boreholes used to estimate geothermal potential (modified by Rob Westaway from Fig. 2.1 of Wheildon et al. (1984), and used with his permission). .....	20
Figure 2 – Schematic of a generic geothermal borehole doublet system .....	21
Figure 3 – (a) Geothermal drilling in Newcastle upon Tyne in 2011 (b) Geothermal wellhead at the Southampton scheme. This photo was taken during maintenance work; usually the wellhead is encased in insulation and is even less conspicuous. ....	22
Figure 4 – Local Wood Chips Production near Banchory (photo: Guy Milligan) .....	23
Figure 5 – Hill of Banchory Biomass Heat Network Development to Date .....	24
Figure 6 – Heat Network Plan .....	25
Figure 7 – Hill of Banchory Energy Centre Plant Room (photo: Guy Milligan) .....	26
Figure 8 – Generalised bedrock geology of the ground west of Aberdeen.....	30
Figure 9 – Bedrock geology of the Banchory district.....	31
Figure 10 – Bedrock geology of the Hill of Fare Granite Pluton .....	34
Figure 11 – Polished surface of a block of Hill of Fare 'main granite' .....	35
Figure 12 – Location of plutons assigned to the Cairngorm Suite.....	36
Figure 13 – Schematic profile of drilled and cased diameters and cement runs for the range of possible geologies (i.e. allowing for a section through the Dalradian) that could be drilled at Banchory .....	43
Figure 14 – Geothermal Gradient Prediction Scenarios for Hill of Fare Granite .....	49
Figure 15 – Estimated thermal conductivity, Hill of Fare.....	53
Figure 16 - (a) Regional Gravity [left-side image], (b) Magnetic Anomalies [right-side image] for a part of north-eastern Scotland (BGS Data (2002)) .....	54
Figure 17 - Location of the observed gravity and magnetic profiles.....	56
Figure 18 – Locations of gravity stations along the track from the main road (A980) to Burnhead Farm.....	57
Figure 19 - Gravity anomalies along the (westerly) profile shown in Figure 17.....	58
Figure 20 - Magnetic anomalies along the (easterly) profile shown in Figure 17.....	59
Figure 21 - Theoretical effect in the induced magnetic field of the contact of a magnetic body and a non-magnetic one .....	60
Figure 22 – Examples of Fracture Systems in granites .....	62
Figure 23 – Fracture Density calculated from borehole cores of the high heat production East Grampian granites.....	63
Figure 24 – Granite Plutons in Scotland.....	67
Figure 25 – Geothermal wellfield in Reykjavik. The wells are in inconspicuous cabins about the size of bus shelters.....	68
Figure 26 – Future Hill of Banchory Heat Network Expansions.....	71
Figure 27 – Heat Demand Density Analysis for Banchory.....	73
Figure 28 - Proposed Heat Networks in Banchory.....	74
Figure 29 – Biomass fuel at the Hill of Banchory Biomass Energy Centre .....	79

Figure 30 - Indicative Cost of Heat Model Outputs .....	85
Figure 31 – Required heat sales for the geothermal well to be financially viable .....	86
Figure 32 – Commercial RHI Biomass Tariffs as of January 2016 .....	87
Figure 33 – Demand projections for the Hill of Banchory Heat Network .....	88
Figure 34 – Cost of heat model cumulative expansion results for proposed Banchory networks .....	89
Figure 35 - Heating System Decision Flow Chart .....	92
Figure 36 – Simplified system schematic for direct geothermal heating in Banchory .....	93
Figure 37 – Unbalanced flow heat exchanger to increase source-side temperature drop .....	94
Figure 38 – Risk Matrix .....	95
Figure 39 – Risk Matrix Post-Mitigation .....	98
Figure 40 – maximum area in which heat demand could be met from geothermal heat from radiothermal granites .....	109

## List of Tables

Table 1 – Heat Production Values for the Hill of Fare Granite, Hill of Fare Microgranite and the neighbouring Crathes Granodiorite.....	47
Table 2 – Heat Flow Estimates of the High Heat Production East Grampian Granites .....	48
Table 3 – Heat Flow, Heat Production and Thermal Conductivity Estimates for Hill of Fare Granite .....	49
Table 4 – Depth to Typical Target Temperatures .....	50
Table 5 – Lifetime Corrected K Values .....	52
Table 6 – Assumed flow rate scenarios for a borehole-doublet scheme in fractured granite .....	66
Table 7 – Future Expansions for the Hill of Banchory Heat Network.....	72
Table 8 – District Heating Network Analysis .....	76
Table 9 – Estimated flow rates for the Hill of Fare granite at Banchory .....	79
Table 10 – Estimated heat available from geothermal resources for given flow rates and temperature drops.....	80
Table 11 – Heat sales required to reach 10% and 20% IRR for wells of differing capacities .....	83
Table 12 - Summary and Evaluation of heating solutions for potential heat production scenarios at the Hill of Fare.....	91

## Executive Summary

### Project outline

This feasibility study explored the potential for a deep geothermal heat project at Hill of Banchory, Aberdeenshire. The geology of the Hill of Fare, to the north of Banchory, gives cause to believe it has good geothermal potential, while the Hill of Banchory heat network, situated on the northern side of the town, offers a ready-made heat customer.

The partners in the consortium consisted of academics and developers with relevant expertise in deep geothermal energy, heat networks, and financial analysis, together with representatives of local Government. They conducted geological fieldwork around the Hill of Fare, engaged with local residents to establish their attitudes to geothermal energy, and built business models to predict the conditions under which the heat network at Hill of Banchory would be commercial if it utilised heat from the proposed geothermal well. They also estimated the potential carbon emission reductions that could be achieved by using deep geothermal energy, both at Hill of Banchory and more widely.

### A vision of how the geothermal heat system would work

The core element of a geothermal heat generation system at Banchory would comprise at least one pair of deep boreholes drilled into the Hill of Fare Granite. The medium for heat transport from the granite would be water: hot water from depth would be pumped to the surface via one of the boreholes, the heat transferred into Banchory via a heat exchanger and water pipes, and the now cooler water would then returned to depth by injection into the second borehole. The following schematic diagram indicates the system layout.

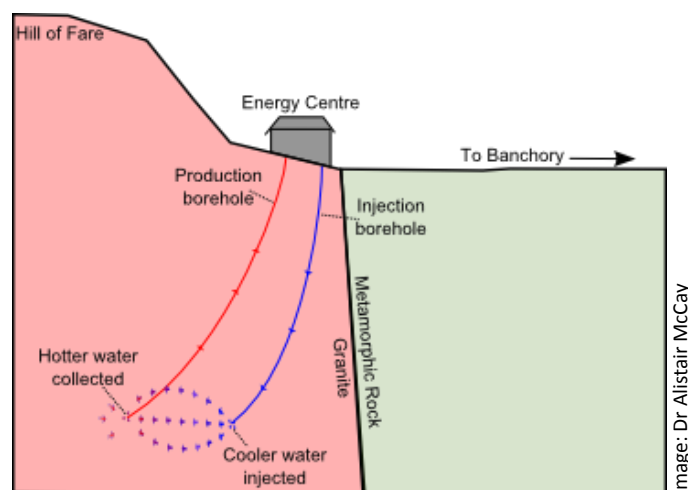

**Figure ES.1 – An indicative diagram of the proposed geothermal doublet at Hill of Fare**

The equipment required at the wellhead would be minimal, and overall the environmental footprint of the system would be very small. A commercially viable system would be expected to have a capacity of a few megawatts, enough to provide heat for a few thousand houses, compatible with the scale of heat demand from the expanding heat networks at Hill of Banchory.

The feasibility of the scheme would depend on the geothermal resource that exists below the Hill of Fare. Sufficiently high temperatures would need to be found, alongside adequate permeability. In other words, the well must be able to sustain the production of a reasonable volume of hot water over the commercial lifetime of the project.

### The Geology of Banchory and the Hill of Fare

The geological element of the feasibility study sought to identify how much heat might be available at the Hill of Fare site, how easily it could be extracted, and whether any aspects of the geology would create problems for a geothermal system.

The country rock throughout the Banchory district belongs to the ‘Dalriadian Supergroup’, a thick sequence of metamorphosed mudstones and sandstones (very little of which is exposed at the surface). Within this are found intrusions of cooled magma, which have formed crystalline granite bodies known as the ‘Caledonian Supersuite’. These granites have long been known to host high concentrations of radioactive elements, which give out large amounts of heat as they decay over geological time spans. This heat production gives them, in theory, good geothermal potential. In this region, a sub-group of the wider ‘Caledonian Supersuite’ occurs, known as the ‘Cairngorm Suite’.

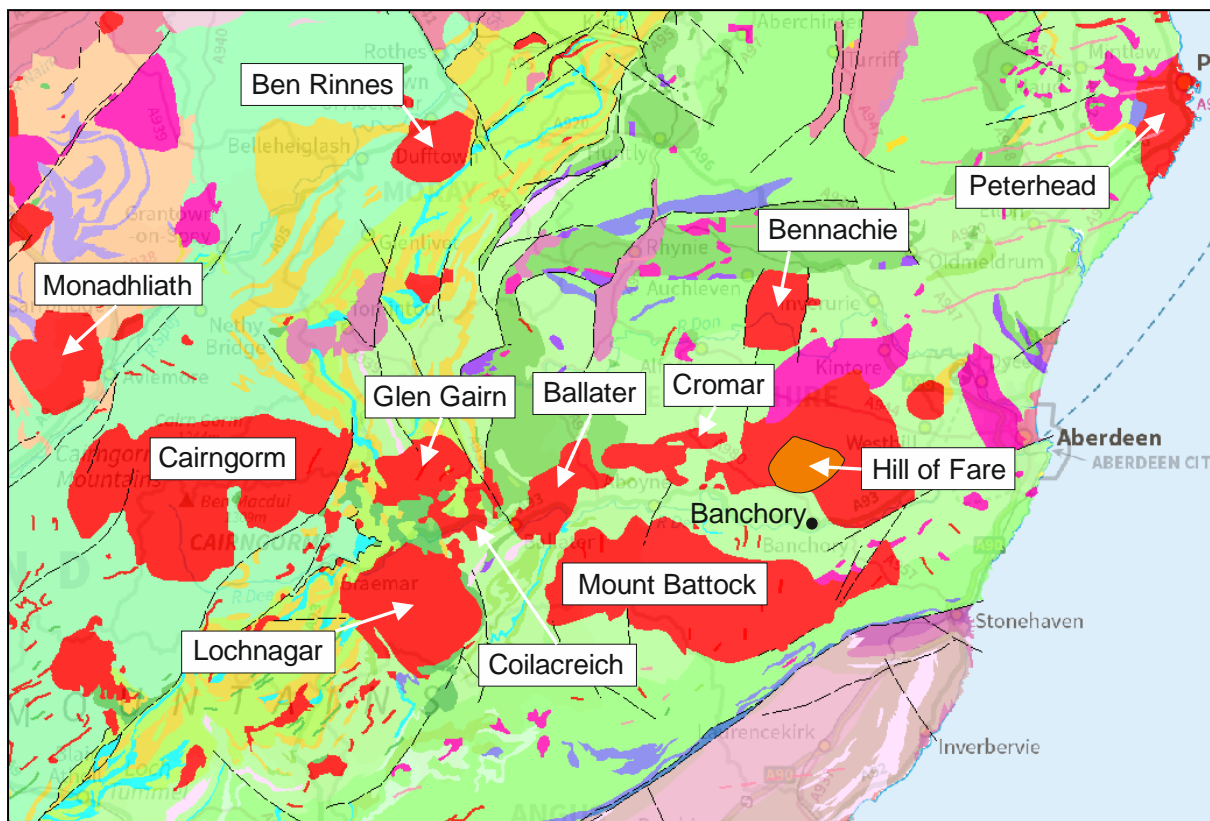

**Figure ES.2 - Location of granite plutons assigned to the Cairngorm Suite (for full citation see page 36).**

One of the constituent members of the Cairngorm Suite is the Hill of Fare ‘Pluton’, essentially a large mass of granite, which sits about 5 km to the north of Banchory. It is c. 8 km across on its longest (east-West) axis and has an area of around 37 km<sup>2</sup>. While it can be expected to extend up to 15 km below ground, all studies of it to date have been confined to

the surface. Observations suggest that the sides of the pluton descend vertically to depth, or may even slope inwards. There is little indication of faulting near the Hill of Fare Pluton, with the exception of one small area to its southeast. No zones of strongly fractured rock were identified, at least at the level of the present outcrop.

Other granites in the 'Cairngorm Suite' were the subject of geothermal research in the 1970s and 80s and were found to have high rates of heat production. Shallow boreholes were drilled to 300 metres in some of the plutons to measure thermal gradients, though these were surprisingly disappointing. However, this can be explained by a failure to correct for the long-term effects of the last ice age (which are still significant to the depths drilled), and the extent to which radiogenic elements are found at depth in the Cairngorm Suite remains poorly understood.

At Hill of Fare, the best exposures of granite are found in disused quarries on the south side of the pluton and that is where our tests were conducted. All of this rock can be classified as types of granite – and it is inferred that a deep borehole drilled anywhere into the Pluton would find only granite.

### **New results of fieldwork at the Hill of Fare – estimating the thermal gradient**

Members of the project consortium made measurements on the exposed rocks (mainly in the quarries mentioned above) to establish the rate of heat production from the Hill of Fare granite. This is measured in micro-Watts per cubic metre ( $\mu\text{W}/\text{m}^3$ ). The University of Glasgow used a hand held gamma-ray spectrometer to measure the concentrations of Potassium, Uranium and Thorium in the granite, from which heat production rates can be reliably calculated. Data were collected at 29 sites across the Hill of Fare, with great care being taken to ensure that measurements were as robust as possible.

In general terms, granites with heat production rates of  $4 \mu\text{W}/\text{m}^3$  or more are generally considered promising geothermal prospects. The Hill of Fare Granite was found to have a heat production rate of  $4.04 \mu\text{W}/\text{m}^3$ . This is lower than some other plutons in the Grampians (e.g. Cairngorm  $7.3 \mu\text{W}/\text{m}^3$ , Ballater  $6.8 \mu\text{W}/\text{m}^3$ , Mount Battock  $4.8 \mu\text{W}/\text{m}^3$ , Bennachie  $7 \mu\text{W}/\text{m}^3$ ) but higher than others (Crathes Pluton  $2.1 \mu\text{W}/\text{m}^3$ , Aberdeen Granite  $2.2 \mu\text{W}/\text{m}^3$ ).

Heat flow at depth can only be established reliably by drilling a borehole and measuring it directly; though this was not possible at the Hill of Fare, the heat flow measurements done at the other East Grampian granites in the 1970s can be used as a proxy. When the original data were corrected for 'paleo-climate' we find heat flows in those four plutons are in the range  $87$  to  $95 \text{ mW}/\text{m}^2$ , consistent with the conditions required for direct geothermal heat generation.

Thermal conductivity is a measure of a material's capacity to conduct heat; granites are usually good heat conductors on account of their high content of quartz – one of the most conductive minerals. Using a 'portable electronic divided bar' at the University of St Andrews, Town Rock Energy Ltd measured 19 plug samples from the Hill of Fare which were found to have conductivity values ranging from  $2.176$  to  $3.682 \text{ W}/\text{mK}$ , which is consistent with previous observations for other high heat producing granites.



Using these figures for heat production, heat flow, and thermal conductivity, well established analytical methods were used to predict how the temperature is likely to vary with depth in the Pluton. For each quantity figures were selected to represent three different scenarios – ‘most favourable’, ‘intermediate’ and ‘pessimistic’. These were used to make three estimates of the thermal gradient as shown in the figure below.

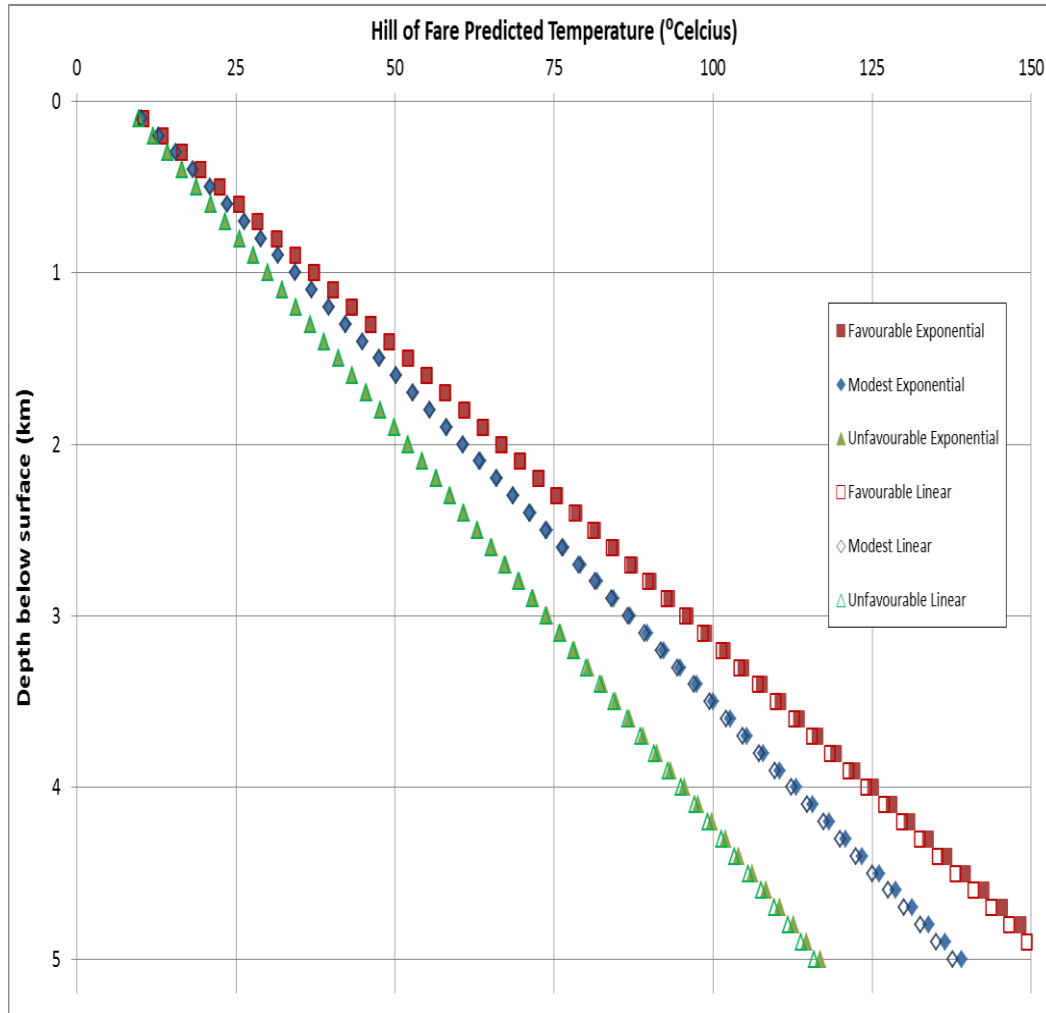

**Figure ES.3 – Geothermal Gradient Prediction Scenarios for Hill of Fare Granite**

These three scenarios produced thermal gradients of 29.0°C/km, 25.9°C/km and 21.1°C /km respectively. If we use these to calculate the depth of borehole required to reach 75 and 90°C, we obtain the following table.

Target Temperature (°C)	Depth to target temperature (km)		
	Favourable	Modest	Unfavourable
75	2.2	2.4	2.9
90	2.8	3.2	3.8

**Table ES.1 – Depth to Typical Target Temperatures**

This suggests that a borehole 2,000-2,500 metres deep would encounter temperatures between 65°C and 82°C. This depth of borehole is entirely practical, and the temperatures are consistent with supplying heat to a heat network.

### **Permeability**

In granite the flow of water is concentrated in fractures and fracture networks, as the permeability of the rock itself is very low. It is hard to predict the extent of fractures at depth in granites.

The range of flow rates observed in similar deep granite settings elsewhere (e.g. Soultz-sous-Forêt, France, and Rosemanowes and Weardale in the UK), indicate that the likely flow rates for a successful borehole-double in fractured granite are in the tens of litres per second. Continuing with the three scenario methodology used above, three flow rate scenarios have been assumed ranging from a most favourable case of 50 litres/second (most favourable) through 15 litres/second (intermediate) to 5 litres/second (least favourable). These figures were used for the analysis of the commercial potential of the Hill of Banchory geothermal scheme.

The range of flow rates observed in similar deep granite settings elsewhere (e.g. Soultz-sous-Forêt, France, and Rosemanowes and Weardale in the UK), indicate that the likely flow rates for a borehole-double in fractured granite are in the tens of litres per second. Continuing with the three scenario methodology used above, the flow rates for a Hill of Fare borehole were estimated to range from a most favourable case of 50 litres/second (most favourable) through 15 litres/second (intermediate) to 5 litres/second (least favourable). These figures were used for the analysis of the commercial potential of the Hill of Banchory geothermal scheme.

### **Borehole design**

The geothermal system will require a minimum of two boreholes of very similar design. Essentially deep water wells, the boreholes must be able to stand open without allowing fine particles to cause clogging, yet allowing the groundwater to enter the borehole at the target depth. This is achieved using the appropriate lining, or 'casing'. (When drilling through a very strong rock like granite, it may be possible to dispense with casing though this will depend on local conditions.)

This report sets out a typical geothermal borehole design. The diameter at the bottom of the borehole is proposed as 9 5/8", with a series of casings widening back to 20" casing at the surface.

### **Output and input temperatures**

An issue which the study identified as being of crucial importance was the need for the output temperature of the geothermal well to be compatible with the input temperature of the

network. The existing Hill of Banchory network designed operating temperatures are 85°C flow/60°C return. The network's heat customers in Banchory have heating systems that are compatible with this temperature range. Delivering heat at lower temperatures would require the operator to make some adaptations to the existing system. Supplying lower temperature heat to future new build properties would have the advantage that suitable changes can be made cheaply at the design stage.

There may be an opportunity here to create heat customers that can use the lower temperatures from the geothermal well. The future refurbishment of council properties could be carried out to make their heating systems compatible with lower input temperatures.

### **The financial viability of a geothermal system**

A key objective of the feasibility study was to determine the commercial feasibility of the overall project –what were the business fundamentals of a geothermal well at Hill of Fare feeding heat into the Hill of Banchory heat network? A financial model was created by Cluff Geothermal and Ramboll Energy to test the relationship between total heat sold, return on capital required, and heat price achieved.

An important income element for the geothermal well - and for the existing biomass heat plant - is the Renewable Heat Incentive (RHI). This is the UK Government's subsidy regime for renewable heat generators. Eligibility to receive the RHI is dependent on repaying any public sector grants that have been received, and receiving RHI income will normally be preferable to keeping the grants. The financial modelling conducted for this project therefore assumed that any grant would be repaid and RHI eligibility restored.

### **Financial analysis: methodology**

There were two elements to the financial analysis. Firstly, a financial model for the geothermal well itself was constructed and used to predict the heat sale price required to achieve various rates of investment return. (A key factor here is the level of annual heat sales; the unit cost of heat supplied is dominated by the up-front capital expenditure, so supplying higher levels of heat increases income while having only a minimal impact on production costs.)

'Central case' assumptions were used for the parameters of the geothermal system (cost of drilling, well heat capacity etc.). There is inevitably some uncertainty in this analysis (as a robust prediction of well output is difficult) but the analysis suggests that a geothermal system at the Hill of Fare would be commercially viable if it could sell around 10,000 MWh of heat a year at 2p/kWh – lower than the market cost of heat from gas and heating oil.

Secondly, a study of the existing heat network established the price at which it made economic sense to purchase heat from an external supplier instead of using the current (biomass) fuel source.

Finally, the outputs of the two analyses were brought together to explore the conditions under which both the geothermal well and the heat network could operate commercially.

The (indicative) graph at figure ES.4 below illustrates this analysis. A geothermal project at Banchory is commercially viable in the part of the annual heat demand range where the green line (the heat price required by the heat network price) rises above the blue line (the heat sale price required by the geothermal well).

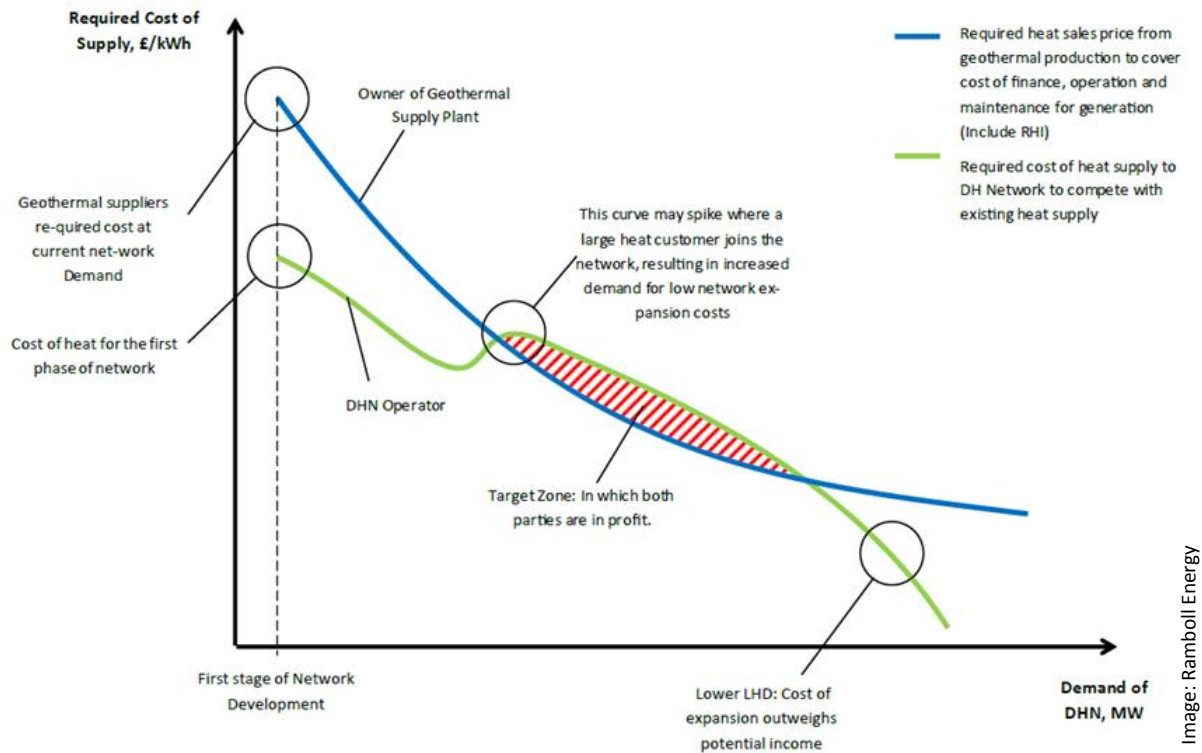

Figure ES.4 - Indicative graph illustrating the 'Cost of Heat' model outputs

## Results of the financial analysis

The Hill of Banchory network currently generates heat from biomass sourced from local forests. This leads to a low heat production cost, competition with which would be challenging for almost all heat technologies. The study concluded that *under its current configuration*, competing against this low cost biomass, it would not be commercially rational for the Hill of Banchory network to purchase heat from a geothermal system, given its likely characteristics.

However, the fuel arrangements at Hill of Banchory are not representative of space heating more widely in NE Scotland, where natural gas and heating oil dominate.

The consortium therefore also considered whether a geothermal well would be competitive against natural gas heating, either in a future phase of the Hill of Banchory network where gas becomes the dominant fuel (it is currently used for back-up), or in a more typical 'generic' gas powered heat network. The conclusion was that it would be competitive against gas. Consideration was given to how the future evolution of the Hill of Banchory heat network

might lead to the use of gas as a fuel, permitting the geothermal heat resource to be exploited.

The Hill of Banchory network does, in fact, use ‘peaking’ gas boilers to meet periods of high demand, and the proportion of heat supplied in this way will increase as the network expands. However, the seasonal nature of peak demand makes it commercially unattractive for the geothermal developer, as heat from the geothermal well will be produced at a steady rate.) On the other hand, the supply of cheap biomass is necessarily limited, meaning that network expansions are likely to utilise gas fuel to meet a high proportion of heat demand.

Future expansion options for the Hill of Banchory network, therefore, could well be compatible with heat from a geothermal well. For example, an expansion of the Banchory town scheme will be taken forward as a low temperature network. This could be connected to the existing Hill of Banchory scheme via a sub-station on the Raemoir Road, which would provide peaking and back-up heat supply. This would allow the network to be developed and supplied by the Hill of Banchory energy centre in the short term, but still enable the supply of heat from the geothermal well in the future (see Figure ES.5, below).

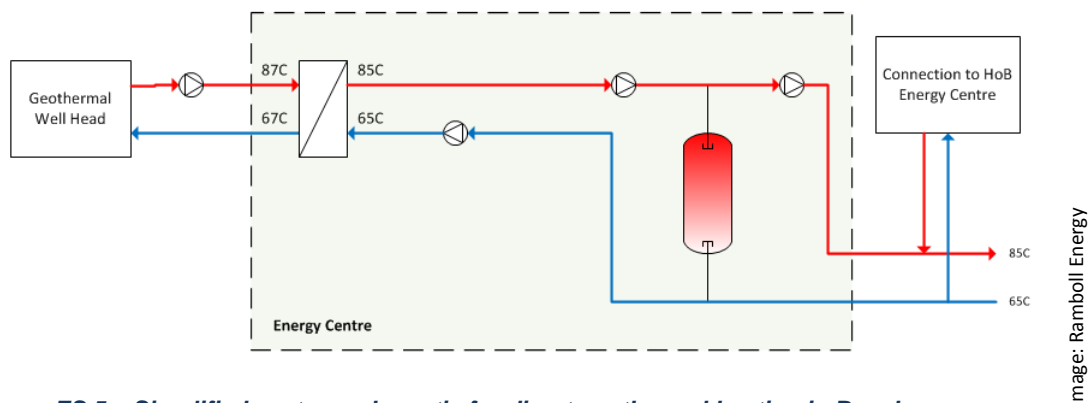

**Figure ES.5 – Simplified system schematic for direct geothermal heating in Banchory**

The conclusion that heat from the proposed geothermal well would be competitive against natural gas, and by extension heating oil, is important as these fuels are used to supply the majority of space and water heating in the NE of Scotland. This suggests that deep geothermal heat systems of the type proposed for Hill of Banchory could be competitive in many locations across the region.

## Risk Registry

A register of risks and opportunities was compiled. The highest risks were the following, in order of decreasing magnitude:

- insufficient permeability or connectivity to sustain flow;
- RHI cutback or abolition;
- district heating return temperature too high; and
- lack of public support.

## **Carbon emission savings**

Deep geothermal energy is widely recognised as a very low carbon energy technology. However there are few reference figures available for its carbon intensity, partly because this will vary from site to site. This feasibility study calculated the carbon intensity of a geothermal heat 'doublet' at Banchory, taking into account the 'embedded' carbon emissions involved in its construction as well as the carbon emitted as a result of operating the pump over the project's lifetime (assumed to be thirty years in this context). The conclusion was that heat from the well would have a carbon intensity in the range 3.5 to 5.4 KgCO<sub>2</sub>/MWh – a very low level.

Using the midpoint of this figure it was estimated that over thirty years a geothermal heat system at Banchory would save around 71,000 tonnes of CO<sub>2</sub>, on the assumption that natural gas heating was being displaced.

Using the Scottish heat demand map, an estimate was also made of the approximate carbon savings available if geothermal heating from radiothermal granites was rolled out to its maximum extent across NE Scotland. The calculation - which necessarily involves considerable assumptions and uncertainties – suggested that radiothermal granite could ultimately meet 5% of Scottish heat demand, and deliver annual savings of around 900,000 tonnes of CO<sub>2</sub> per year.

## **Community Engagement**

HOBESCO, the operators of the Hill of Banchory heat network, held a community event for local people at which a questionnaire survey was conducted. Around two thirds of respondents thought they had a 'medium' knowledge of geothermal energy, with the rest in the 'low' category: indicating that local knowledge of deep geothermal energy is (unsurprisingly) relatively sparse. However, support for developing geothermal energy in Scotland was very high, as was the idea that this should be supported by Government. There was also widespread enthusiasm from respondents for the idea that the heat they received should come from geothermal energy.

## **Recommendations, Strategic Implications and Next Steps (set out in full at pages 114 to 116)**

This feasibility study has confirmed that there is a promising prospect for a geothermal heat generating system at Banchory, increasing confidence that generating renewable heat from Scotland's radiothermal granites is viable. It represents a positive strategic development in the context of Scotland's wider quest for affordable low carbon heat.

The geothermal potential of the Hill of Fare granite has been found to be greater than had been supposed, though some uncertainty inevitably remains. Heat from a geothermal well at Hill of Fare would probably not be competitive with the unusually cost-effective biomass fuels currently used by the Hill of Banchory heat network, but it would be competitive against natural gas and heating oil, the dominant heat sources in the NE of Scotland. Furthermore,

as the Banchory network expands it is likely to become more gas-dependent, creating the necessary conditions for the Hill of Fare geothermal project to become commercial.

There is scope to use this project's findings as a template for other appraisals in similar locations across Scotland. The high-level analysis of the full technical potential of radiothermal granites suggests that as much as 70% of the total head demand in the adjacent regions could come from this source. This is equivalent to around 5% of total Scottish heat demand, and this figure could increase further as other potential geothermal sources elsewhere in Scotland are explored.

The next steps for the project should include:

- pilot drilling to improve understanding of the thermal gradient and granite permeability;
- further geophysical studies;
- identification of funding;
- achievement of regulatory approval for the drilling and geophysical testing mentioned above;
- liaison with local landowners to identify possible drill sites and wayleaves for pipelines; and
- events to increase public engagement with deep geothermal energy locally and nationally. This should include opportunities for the public to experience the drilling of a test borehole at first hand.

## 1. Introduction

### Why deep geothermal energy?

Deep geothermal energy has the potential to provide some of the low carbon, sustainable energy that Scotland needs to meet its objective of a 42% reduction in greenhouse gases by 2020 compared to 1990 levels, as well as increasing energy security and combatting fuel poverty. The size of contribution the technology can make will depend on the geothermal potential of Scotland's deep geology and on the engineering and economic challenges in exploiting suitable geology. Our understanding of that potential is still at an early stage, as no deep geothermal boreholes have yet been drilled in Scotland.

Deep geothermal energy can in principle be tapped to provide power and / or heat. The former requires high rock temperatures: more than 130 °C, whereas successful heat-only geothermal systems can be based on temperatures of 60-70 °C. All indications to date are that the Scottish geothermal resource base is most likely to be a useful source of low carbon *heat*, with only limited and localised scope for combined heat and power (CHP).

Identification of a substantial low-carbon heat source is good news, as the majority (55%) of Scotland's energy consumption is heat-related, and heat gives rise to more than half of our carbon emissions; hence it is essential that low carbon heat be rolled out at scale if our long-term climate change targets are to be met. Yet there are few low carbon heat technologies available at a large enough scale to really make a difference; hence, if it proves viable, deep geothermal heat could emerge as a significant source of decarbonised heat for Scottish homes and businesses.

### Why Banchory?

Hill of Banchory has all the hallmarks of a potential deep geothermal demonstrator site, as it combines an apparently attractive geological setting with an existing, large-scale local heat customer.

As will be explained in Chapter 4, one obvious place to start looking for deep geothermal heat is the suite of granite 'plutons' – huge masses of largely subterranean rock – that form much of the Grampian mountain chain. Enormous amounts of heat are present in these plutons, both conducted from greater depths and produced *in situ* by the slow decay of radioactive elements. One such pluton, the 'Hill of Fare', is located just north of Banchory. Helpfully, this granite is exposed in several quarries on the flanks of the eponymous hill, making it easy to take samples.

The Hill of Banchory heat network, meanwhile, has been in operation since 2008, combusting locally-sourced wood chips to supply heat to houses and businesses on the north side of Banchory. The network has significant options for expansion both from the ongoing new development at Hill of Banchory and across the wider town, including from large public sector buildings. Its energy centre already features a 100 m<sup>3</sup> thermal store (a hot water tank) which would greatly assist in the efficient exploitation of a deep geothermal heat source: as heat would be produced continuously by geothermal boreholes, a heat store



allows efficient smoothing of time-lags between peaks of heat demand and steady production (Kyriakis and Younger 2016). The Energy Centre also has back-up gas boilers already installed.

In short, the Hill of Fare may well possess suitable geology for geothermal heat production; and such heat, if produced, already has a large local heat customer in place. At this point in the history of low-carbon heat development, this is a highly unusual set of circumstances, not just for Scotland but for the wider UK, making Banchory an exceptional site for a deep geothermal demonstrator project.

### **The Project Team and timeline**

The members of the Hill of Banchory Geothermal Energy Consortium brought together the academic and commercial skills required to assess the technical feasibility of a deep geothermal energy project at Banchory and the financial and regulatory knowledge to model its commercial viability. It comprised:

- HOBESCO/Jigsaw Energy, the owners and operators of the Hill of Banchory heat network;
- Leading academic experts in the fields of geology and deep geothermal energy from the Universities of Glasgow and Aberdeen;
- British Geological Survey – Scotland;
- Cluff Geothermal, a London-based deep geothermal company;
- Ramboll Energy, a global Energy Consultancy;
- Town Rock Energy, a Scottish deep geothermal consultancy; and
- Aberdeenshire Council.

The project team was assembled in March 2015 and, following the successful application to the Scottish Geothermal Energy Challenge Fund (part of the Low Carbon Infrastructure Transition Programme, LCITP), met again in late June 2015 to formulate a project plan. The team committed to deliver the following:

- a detailed geological assessment of Banchory as a location for a heat-only geothermal borehole doublet system;
- a detailed operational and financial model of the whole system, including provisional borehole design, an assessment of the potential heat production based on analysis of the local geology, a risk management strategy, and the extent to which the geothermal heat resource is complementary to the existing heat network;
- an estimate of potential carbon savings;
- a report on community attitudes towards a potential scheme; and
- a final feasibility study report.

The end-date for the project was expected to be early 2016. Initial fieldwork (gamma spectrometry and heat conductivity measurements) was carried out in July-August 2015, with a gravimetric survey carried out in October (when equipment became available).

The data collected were analysed in November and early December to produce an initial model of the sub-surface geology underlying Hill of Fare and Banchory. Drawing on this, the team also produced a provisional borehole plan, and commentary on the likely location for a drill site.

The financial model was developed over the period July-December 2015. Initial data from the geological fieldwork were used to make estimates of the cost of drilling, and the likely yield from the well (though until preliminary drilling takes place, this factor will remain subject to much uncertainty). This in turn allowed a financial model to be constructed of the likely cost of heat production from the geothermal well. In parallel, a financial model was constructed of the necessary price requirements of the Hill of Banchory heat network.

Integrating these two parts of the financial model answers, at least provisionally, a key question: could the geothermal well produce heat cheaply enough to be competitive with the current cost of heat to the heat network?

This analysis was complicated by the fact that the Hill of Banchory heat network utilises low-cost locally-sourced biomass. In the interests of producing a result that could inform thinking at most other locations, the decision was taken to consider natural gas as the competitor fuel.

A local community event held in November 2015 related to new housing developments in the area included information on the use of renewable energy to heat the properties provided an opportunity for people to learn of the project and to ask questions. Attendees' opinions were surveyed, as well as those of the existing customers of the Hill of Banchory Heat Network. As a member of the project team and a potential large user of heat in its own right, the views of Aberdeenshire Council were also extensively canvassed. Thirdly, local landowners were consulted and their support gained for the location of any potential future plant infrastructure.

The project team also carried out analysis on the likely carbon emissions reduction that would be delivered by a fully functioning deep geothermal heat network at Banchory. Again, this was done on the basis that natural gas is the fuel being replaced. As deep geothermal heat is an exceptionally low carbon technology, the potential carbon emissions savings versus fossil fuels are enormous.

Finally, the team produced a risk assessment for the geothermal well, and made recommendations on what the conclusions of this project imply for the wider deep geothermal energy potential of Scotland.

### **Purpose of this report**

While this report primarily examines the feasibility of expanding the Hill of Banchory heat network by addition of a geothermal heat source, the conclusions and recommendations given in Chapter 14 have been drafted such that they might assist Scottish Government as it considers the future path of low carbon and renewable energy development.

## 2. Background to Deep Geothermal Technology

### Heat at depth

Geothermal energy harnesses heat that occurs naturally below the ground surface. Heat is present within the Earth due to processes that relate to the formation of the planets and the natural decay of radioactive elements. Humankind has long taken advantage of geothermal waters where they naturally emerge on to the Earth's surface. Spa towns were often built around zones where faults have provided pathways for easy harnessing of hot geothermal fluids – although many Victorian spas exploited springs of indifferent temperature (e.g. at Strathpeffer and Bridge of Allan). Modern geothermal energy developments do not rely on natural springs, however, but engineer the subsurface to sustainably exploit the renewable heat contained in the Earth's crust.

The key principle of geothermal energy is that temperature increases with depth; the rate at which this occurs defines the “geothermal gradient”. In the UK the geothermal gradient ranges from about 20 to 40°C/km, with higher rates tending to coincide with heat-producing granites. The higher (or ‘steeper’) the geothermal gradient, the more likely we are to find useable quantities of heat at relatively shallow depths in the Earth and hence an elevated geothermal gradient is generally a favourable indicator of a potentially exploitable geothermal resource.

Deep geothermal schemes exploit hot waters captured at depths of anywhere between 300m down to 5km. Although this appears deep, these depths are still well within the uppermost portions of the Earth's crust (the solid “outer skin” of our planet which rests upon the partially molten high-temperature, high-pressure zone of the Earth's mantle). The crust is made up of many different tectonic plates, with boundaries separating them. The movement of these tectonic plates causes crustal thinning and collision zones creating tectonically derived geothermal hotspots such as Iceland or New Zealand, both of which are significantly exploiting their geothermal resources. However Scotland (and UK) is in the middle of the Eurasian plate far from any tectonically derived hotspots; this has the benefit of a lack of major geological hazards such as large earthquakes or volcanoes, but at the cost of more modest geothermal potential. Such seemingly unfavourable conditions have meant that little progress has been made in exploiting geothermal in Scotland. Nevertheless, there are significant resources to be explored, and similar resources are now being targeted elsewhere in the world; these are generally referred to as low to mid-enthalpy systems (Younger 2014) due to the generally cooler temperatures compared to other tectonically derived resources such as those in Iceland.

### The East Grampian Granites

The heat that we could harness under Scotland comes from two main sources (1) heat conducted from the mantle below the Earth's crust and (2) heat produced within the crust by decay of radioactive elements. Additionally, heat can also be distributed and placed in the upper crust of Scotland due to convective flow of hot ground water from depth.

The granites of the East Grampians have long been known to host high concentrations of the radioactive elements potassium (K), uranium (U), and thorium (Th) (Downing and Gray 1986, McCay *et al.* 2014). These granites were investigated previously by drilling heat flow boreholes (Figure 1). Temperature measurements in these boreholes found that the radioactive heat production significantly increases their geothermal gradient compared to the surrounding metamorphic Dalradian Supergroup rocks. However the geothermal gradient appeared not to be as high as in other UK high-heat production granites (Downing and Gray 1986). As such, the East Grampian granites were not further pursued as a geothermal resource during the studies in the 1980s, because the exploration paradigm at the time was solely to find locations suitable for the production of electricity – which is a much more challenging ambition in the UK.

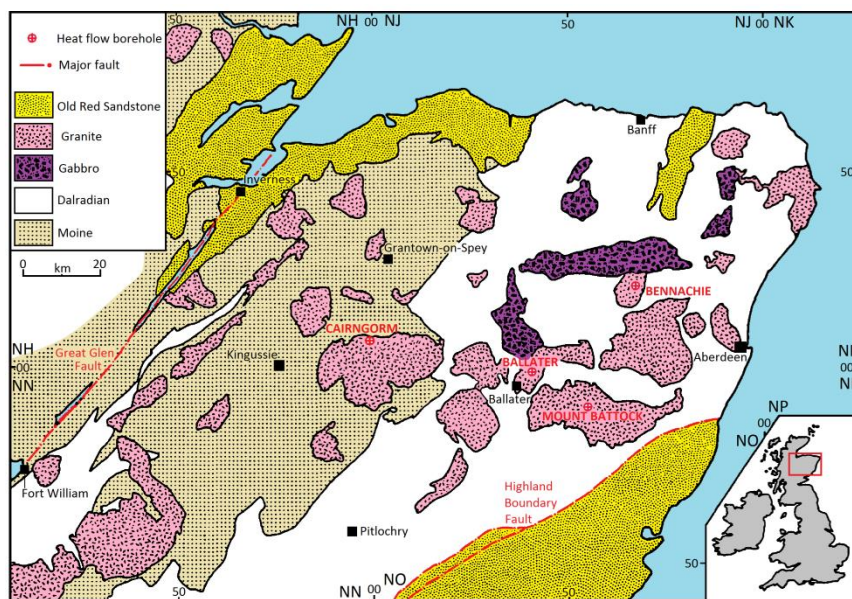

Figure 1 – Location of granite bodies in north east Scotland and the heat flow boreholes used to estimate geothermal potential (modified by Rob Westaway from Fig. 2.1 of Wheildon *et al.* (1984), and used with his permission). NB Areas shown as ‘Moine’ rocks south of the Great Glen Fault should be white – this colour indicates Dalradian and other metamorphic rocks.

More recent reappraisal of the apparently disappointing geothermal gradients in the East Grampian granites has restored their attractiveness for geothermal prospecting, by accurate accounting for the remnant effect of the last ice age, which led to an underestimation of the geothermal gradient from the few available measurements from relatively shallow boreholes in the region (Westaway and Younger 2013, Busby *et al.* 2015).

### Extracting the heat

A geothermal development involves drilling to the appropriate depth to extract the geothermal heat. In granite the heat is primarily contained within the rocks so we must use the circulation of fluids to extract the heat; by using the geo-fluids as a heat exchange medium. If these heated fluids were merely extracted, like an oil or gas reservoir, then the geothermal reservoir could suffer excessive drawdown and performance would be significantly affected. Therefore sustainable geothermal schemes use borehole-doublet systems, which consist of pairs of boreholes, one used for abstraction, the other for re-

injection (Figure 2). As the fluid is circulated between the boreholes it picks up the heat from contact with the rock. Pressure is maintained in the system by re-injecting the fluids after their heat is extracted by a heat-exchanger at surface. The rate of injection and production of fluids can be designed to be in balance with the natural heat replenishment in the subsurface to ensure that a geothermal scheme has a lifespan of several decades before major refurbishment is required.

Figure 2 shows a schematic of a generic geothermal borehole doublet system. To illustrate the scale of the depth of the operations the Troll A Oil Platform and Castlegate (on Union Street, Aberdeen) are shown at the land surface on the image. The left box shows a likely transit pathway for fluid as it flows through the rock from an injection borehole to a production borehole. As the water flows through the rock it warms up as it picks up the naturally occurring heat. The example here does not show any fractures or faults in the rock, however these would be likely to be naturally present within the granite and would create a more complicated fluid flow pathway between the boreholes.

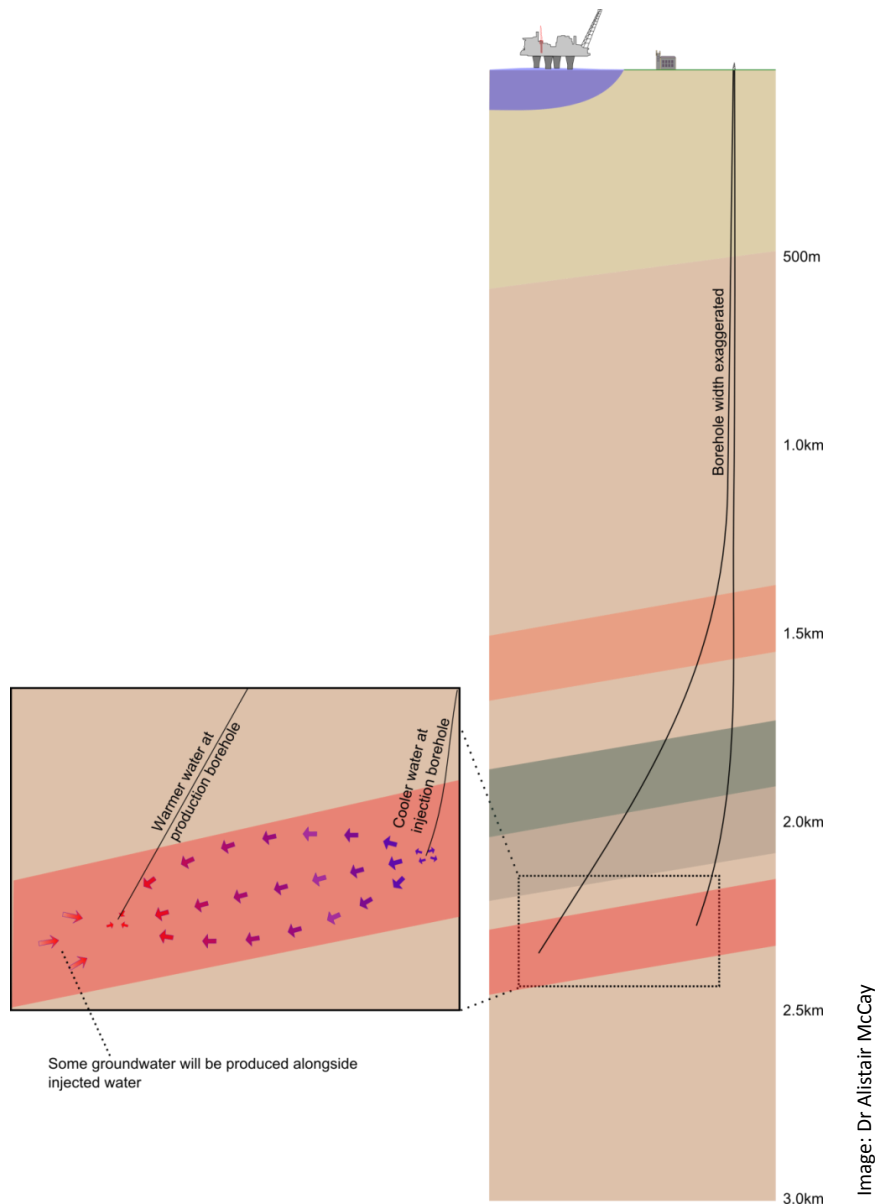

**Figure 2 – Schematic of a generic geothermal borehole doublet system**

Drilling is required to access the depths where the geothermal sources are located. The techniques used in geothermal drilling are similar to those of oil and gas exploration and production. Temporary drilling rigs (an example of which is shown in Figure 3a) are required to be on site during exploratory and production drilling. This process can take several weeks. Once the drilling is completed the rig is removed and a permanent well head is left in place. Figure 3b shows an example of a wellhead from the Southampton geothermal scheme. Here, the wellhead is unobtrusively located in a commercial car park.



Photo: Paul Younger



Photo: ENGIE

Figure 3 – (a) Geothermal drilling in Newcastle upon Tyne in 2011 (b) Geothermal wellhead at the Southampton scheme. This photo was taken during maintenance work; usually the wellhead is encased in insulation and is even less conspicuous.

### 3. The Hill of Banchory Biomass Heat Network

#### Background

Banchory is a small rural town of approximately 8,000 people, located in Deeside, Aberdeenshire (Figure 4). Popular with Aberdeen commuters, the town has seen considerable expansion in recent years. Hill of Banchory is a development by North Banchory Company on the north east edge of the town, which includes residential commercial and community buildings.<sup>1</sup>

#### Sustainable Development

North Banchory Company (NBC) set sustainability at the heart of Hill of Banchory. In seeking a low carbon energy solution, NBC conducted a technical options appraisal and decided to build a Biomass Energy Centre and Heat Network.

Given the abundant local forest resources, and a long tradition of forestry in Deeside, biomass was a natural choice for providing a renewable heat resource. A capacity study concluded that sufficient timber could be sourced locally without impacting supply of established industries. Woodfuel could be produced at affordable prices, and local businesses would receive a new income stream.



Photo: Guy Milligan

Figure 4 – Local Wood Chips Production near Banchory

<sup>1</sup> See <http://www.banchoryfutures.co.uk/Banchory/home.html>.

Whilst Heat Networks are not yet widely used in Scotland, particularly incorporating biomass, they are commonplace in continental Europe and are a cost-effective and energy efficient way of providing distributed energy. A Heat Network comprises a network of pre-insulated pipes which deliver heat, in the form of hot water, from the point of generation to the final customer. Networks vary in size and length, from small schemes supplying heat to 2 or 3 houses, to city-wide schemes with tens of kilometres of pipes supplying heat to entire communities and industrial areas. They are flexible in design, allowing new customers to be added simply by extending the pipework and adding new heat sources as necessary. These heat sources are diverse and can include renewable energy such as biomass, energy from waste facilities and geothermal sources.

## Project Development

In order to drive forward its sustainable vision for Hill of Banchory, North Banchory Company created a new subsidiary company, Hill of Banchory ESCo (HOBESCO), tasked to design, build, own and operate the Biomass Energy Centre and Heat Network. Its primary objective was to provide the new development with affordable green heat.

The Hill of Banchory Biomass Heat Network was designed to be built to support the development as it progresses, which has required a flexible solution. The phases of project development to date are shown in Figure 5.

### Heat Connections

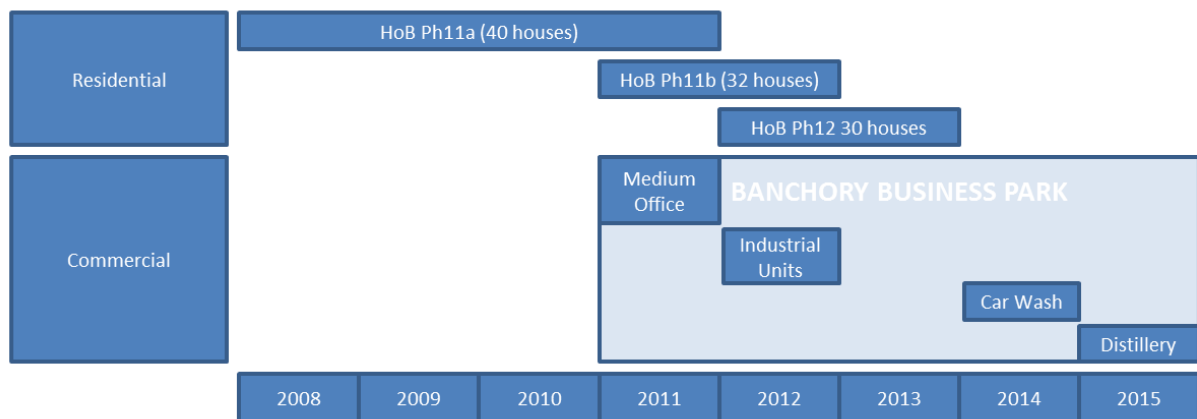

### Heat Generation Source

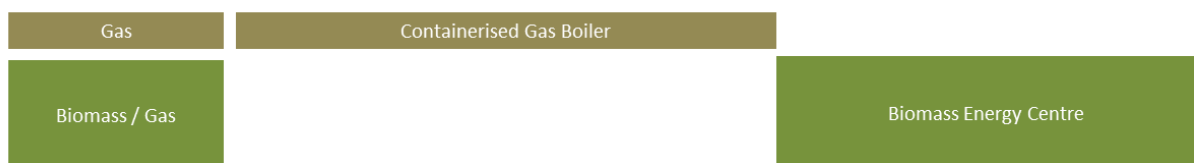

Figure 5 – Hill of Banchory Biomass Heat Network Development to Date

The first buildings to be connected to the Heat Network in 2008 were residential properties. Heat demand from these is relatively low, particularly during the day and summer months,



and could be provided from a temporary 1.1MW containerised gas boiler. As the Network was expanded to Banchory Business Park, the increased heat demand from offices and commercial enterprises and improved load balancing (day/night usage), enabled the Biomass Energy Centre to become the heat generation source. The Biomass Energy Centre was commissioned in 2012 and the temporary gas boiler was removed from service.

The Energy Centre has the capacity to provide heat to current and future development at Hill of Banchory, as shown in Figure 6. The Energy Centre is centrally located to provide heat to the development areas as detailed. In 2016 residential properties are planned to be built at the Neighbourhood Centre and at Lochside of Leys, resulting in a further 400 homes over the next 10 years. The Neighbourhood Centre will also include a leisure centre including swimming pool to be built by Aberdeenshire Council in 2016, which could be a large and important heat user, and discussions are being had about potential connection. Other potential buildings include retail and a care village for elderly people.

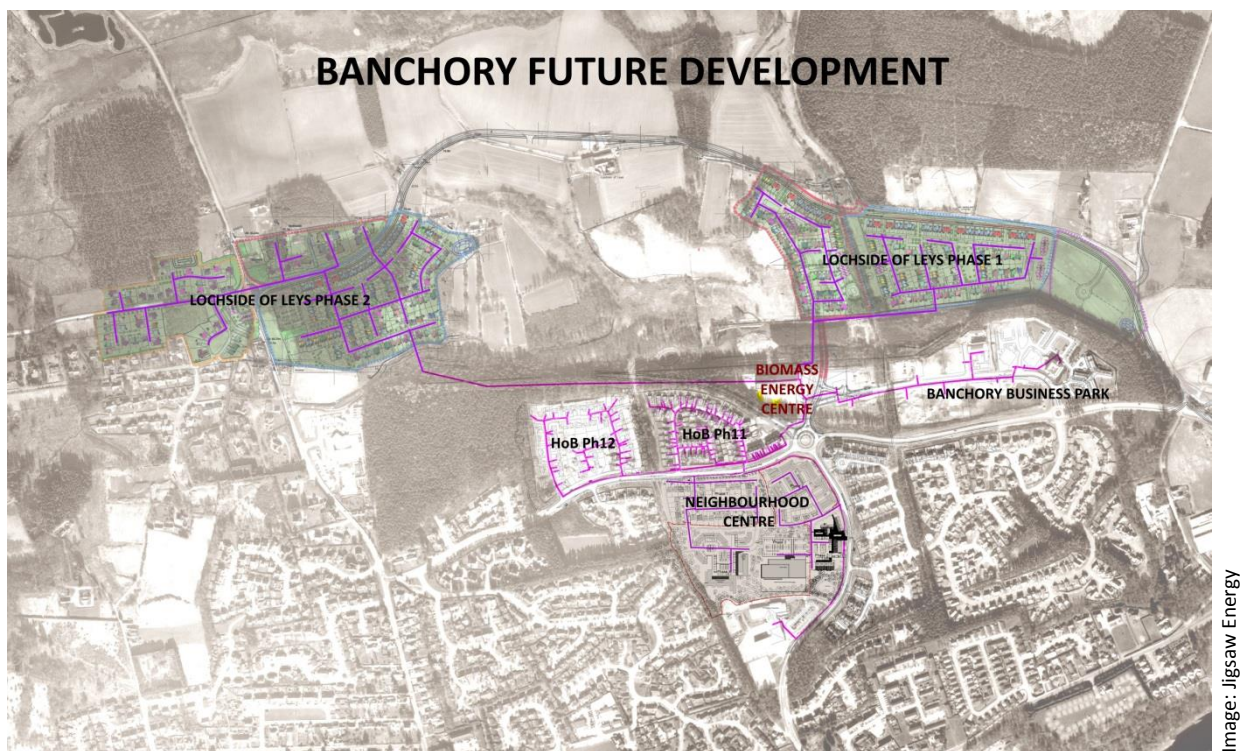

Figure 6 – Heat Network Plan

### Biomass Energy Centre

The Biomass Energy Centre (Figure 7) comprises a primary 900kW biomass boiler and two gas back-up boilers. A second 700kW biomass boiler will be commissioned as more connections are made and heat demand increases. The biomass boilers are integrated with two 50,000 litre thermal stores (hot water tanks) to ensure efficient operation.

Biomass supplies the base load heating requirement, and will account for 70% of total heat generated when the Network is fully built out. Gas will supply the remaining 30% of total heat generated, providing a top-up to the biomass boilers in meeting peak loads, which can be more cost-effectively achieved than biomass.

By incorporating multiple boilers and fuels, the Energy Centre provides resilience in being able to continuously supply heat should plant failure occur. The Energy Centre also has space for additional boilers, or CHP, providing flexibility to allow for the evolving nature of the development.



Photo: Guy Milligan

**Figure 7 – Hill of Banchory Energy Centre Plant Room**

The Energy Centre has generated 11,000MWh heat to date, with 90% from biomass. As a very low carbon fuel, biomass has saved 1,800 tCO<sub>2</sub>e compared with natural gas, making an important contribution in reducing greenhouse gas emissions to the atmosphere.

### **Customer Satisfaction**

HOBESCO is committed to delivering excellent levels of customer service, and The Hill of Banchory Biomass Heat Network is very well supported by its existing customers.

HOBESCO recently conducted its biennial Customer Survey<sup>2</sup> in which 89% of customers stated that they were either satisfied or very satisfied with their heat supply. The majority of customers (74%) supported being part of a communal heating system, and 66% considered receiving their heat from a renewable source as being either important or very important. 54% of customers felt that the cost of their heating represented value for money. Whilst this is lower than desirable, customers' opinions are likely influenced by currently low oil and gas prices. Despite expressing some concerns on current price competitiveness, no customers have chosen to disconnect from the Heat Network.

---

<sup>2</sup> Survey results can be found at <http://www.hobesco.com/>

The housebuilder, Bancon Homes, has supported the Heat Network since the first connections were made in 2008, which as a long-term investment in renewable energy has been vital. Bancon's Planning Director, Harry McNab said;

*'We are very satisfied with the biomass heating system which has enabled us to provide our customers with more sustainable homes in Banchory, and with the satisfaction that their heating is produced from a local renewable energy resource. District heating integrates very easily with our homes and is simple for our customers to use. We are fully supportive of HOBESCO's Hill of Banchory Biomass Heat Network and it is our intention to connect additional new homes as part of our rolling build programme over the next 10 years. It is very interesting that geothermal energy might be added to the energy mix, which we welcome as another locally produced renewable resource.'*

## 4. Geological Background

### Introduction

Any study of the feasibility of a potential geothermal energy project needs to address three key questions regarding the geological suitability of the selected site.

1. **How much heat is in the target rock mass (and is there enough to sustain a viable energy distribution scheme)?** The size of the heat resource at any given point in Earth's crust depends on *heat flow* at that point, which in turn depends on the amount of heat emanating from deep in the Earth (*background heat*) and any contribution made by heat generated in the rock by the radioactive decay of naturally occurring elements (*radiogenic heat*). Heat flow can only be measured accurately in a deep borehole, but the amount of radiogenic heat created by any rock (i.e. its *Heat Production capacity*) can be measured in an outcrop or a hand sample.
2. **Is the heat readily extractable?** Currently, all tested technologies for accessing deep geothermal energy use water to transport heat from depth to the surface (via one or more boreholes), so this really is a question about how much water can be abstracted sustainably from the rock mass at a given depth. This in turn depends on rock permeability and the amount of water that is accessible within a network of permeable features.
3. **Are there geological factors that might complicate or constrain the process of accessing and extracting heat?** Such factors might include: geological structures and rock properties that have the potential to cause drilling problems; groundwater that is naturally corrosive or polluting if brought to the surface; and physico-chemical conditions in the network of permeable fractures that might cause new minerals to precipitate, thereby reducing the permeability of the system over time.

The Banchory area was identified as a good target for a geothermal energy feasibility study because of two key factors: (i) the presence at Hill of Banchory of an existing biomass- (and gas-) fuelled district heating scheme that could be adapted to incorporate geothermal energy; and (ii) the relative proximity to the district heating scheme of a geological unit with the potential to provide above-background levels of geothermal energy. This geological unit – the Hill of Fare Granite Pluton – is reported to have elevated concentrations of radiogenic elements at outcrop, raising the possibility that it is, or is close to being, a body of High Heat Production granite (Gillespie *et al.*, 2013). The pluton (which simply means *large intrusion*) crops out about 5 km to the north of Banchory, so a successful project would require the district heating scheme and a geothermal borehole to be connected by a pipeline.

This section of the report presents a review of the geology of the Hill of Fare pluton and, as far as the available information allows, addresses the questions set out above.

In common with other large granite intrusions in the region, the Hill of Fare pluton is a three-dimensional body of rock that may extend 5, 10 or even 15 km into the subsurface. However, no boreholes have been drilled into the pluton, so all of the available published information about it comes from observations at the ground surface. For this reason this section of the report includes some information from other nearby intrusions of granite that

are believed to be related to the Hill of Fare pluton and could be considered analogues of it; shallow boreholes have been drilled into some of these intrusions.

A general introduction to the geology of the Banchory district is also presented to provide geological context.

## **Geology of the Banchory district**

### **Bedrock**

Most of north-east Scotland, including the town of Banchory, is underlain by the *Dalradian Supergroup*, a thick sequence of metamorphosed sedimentary strata consisting mainly of interlayered beds of sandstone and mudstone, with occasional beds of limestone and other rock types. The original sedimentary rocks were altered by high heat and pressure (metamorphism) between 500 and 400 million years during a major tectonic event, the *Caledonian Orogeny*, which accompanied a collision of tectonic plates. During metamorphism sandstone became metasandstone (also known as *psammite*) and mudstone became metamudstone (also known as *pelite*). Another effect of the Caledonian Orogeny was to cause widespread melting of rocks deep in Earth's crust, with the result that numerous large and small bodies of magma were emplaced into the Dalradian strata where they cooled to form intrusions of crystalline igneous rock. These intrusions collectively are known as the *Caledonian Supersuite*. Rapid uplift and erosion of the crust during the Caledonian Orogeny brought to the ground surface rocks that previously had been up to 10 km deep. These rocks form the bedrock of north-east Scotland today.

The bedrock throughout the Banchory district is formed entirely of geological units assigned to the Dalradian Supergroup and the Caledonian Supersuite (Figure 8). The town of Banchory is underlain by two units of the Dalradian Supergroup; the Queen's Hill Formation, which consists of interbedded and partly melted psammite and pelite, and the Tarfside Psammite Formation, which consists mainly of psammite. Several large and many small intrusions of the Caledonian Supersuite - including the Hill of Fare Granite Pluton - crop out in the ground around Banchory (Figure 10); part of the Crathes Granodiorite Pluton underlies the eastern-most edge of the town.

The Dee Fault is a large geological fault that extends from the coast at Aberdeen into the ground south of Banchory, and truncates the southern edge of the Crathes Granodiorite Pluton (Figure 8). Other than this structure, very few geological faults are recognised in the Banchory district. Poor exposure means that smaller faults may simply be concealed, but the lack of obvious large offsets in any of the mapped geological boundaries in the district suggests there are few large faults near to Banchory and the Hill of Fare pluton.

### **Superficial deposits**

For the past 2.6 million years Earth has been in an Ice Age, with higher latitudes experiencing alternating periods of cool (glacial) and warm (interglacial) climate. The landscape of north-east Scotland has been modified in two ways by the Ice Age. During periods of ice formation and advance the bedrock surface locally has been scoured and

sculpted by moving ice (this effect is most pronounced at higher elevations where ice streams have carved out glacial valleys and localised accumulations of ice on slopes have produced corries) and in places has been 'plastered' in a layer of poorly sorted, clay-rich sediment (*till*) that formed beneath ice sheets. In flatter, lowland areas (such as Banchory) the ice caused little focussed erosion but instead produced a widespread general denudation of the land surface. During periods of ice melting and glacier retreat meltwater channels formed at the margins of glaciers and beneath glaciers, scouring out v-shaped channels, and glacial rivers deposited vast quantities of sand and gravel in mounds and fans.

Bedrock exposure around the town of Banchory is generally very poor: nearly all of the bedrock in the local area is concealed by vegetation, soil and glacial deposits, or by alluvium and river terrace deposits on the banks of the River Dee.

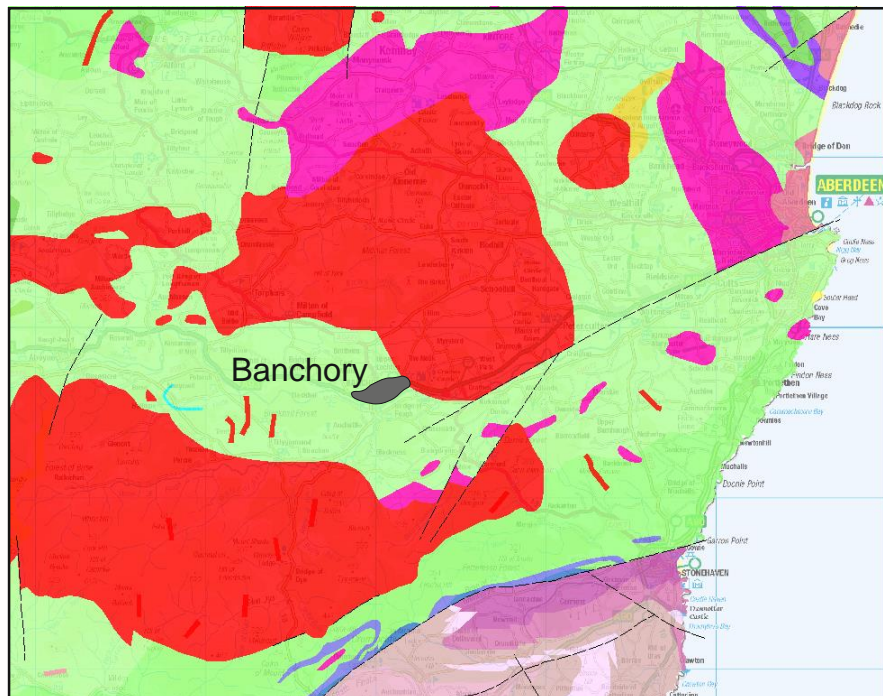

Contains British Geological Survey materials © NERC 2016

**Figure 8 – Generalised bedrock geology of the ground west of Aberdeen. The dark grey polygon represents the approximate extent of Banchory. Coloured polygons representing generalised bedrock units from the BGS Digital Geological Map of Great Britain 1:625,000 scale model are superimposed on the OS 1:250,000 scale topographic map. Key to colours: green = Dalradian Supergroup; red, purple and orange = Caledonian Supersuite; brown = Old Red Sandstone Supergroup. Dashed black lines are geological faults.**

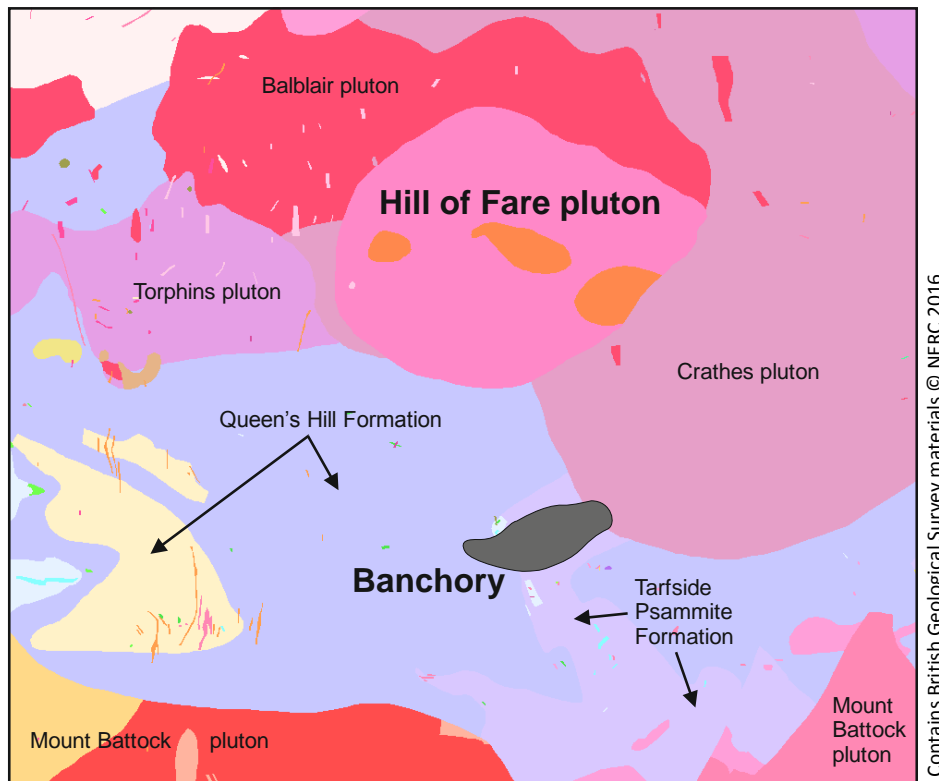

Contains British Geological Survey materials © NERC 2016

**Figure 9 – Bedrock geology of the Banchory district. The dark grey polygon represents the approximate extent of Banchory. Coloured polygons representing bedrock units are from the BGS Digital Geological Map of Great Britain 1:50,000 scale model.**

### Hill of Fare Granite Pluton

The Hill of Fare pluton has been mapped in detail by British Geological Survey but has not been the subject of detailed geological research. The information presented in this section is based on a review of the published BGS 1:50,000 scale geological map sheet encompassing the Hill of Fare and surrounding country (Sheet 76E Inverurie; BGS 1992), the unpublished BGS 1:10,000 scale field geological maps of Hill of Fare, and a review of rock and thin section<sup>3</sup> samples held by BGS.

### Extent and topography

The Hill of Fare pluton has a roughly pear-shaped outcrop and is relatively small compared to many plutons, measuring c. 8 km on its longest (E-W) dimension, 6.5 km on its shortest (N-S) dimension, and with a surface area of around 37 km<sup>2</sup>. The pluton underlies a topographically upstanding massif, the Hill of Fare; the ground overlying the pluton rises gently on all sides from a base at ~ 100-200 m OD to an extensive area of undulating upland with a high point of 471 m OD. The close spatial coincidence between the Hill of Fare massif and the Hill of Fare pluton leaves little doubt that the massif has formed because the underlying granite has in general eroded at a slower rate than the surrounding rocks.

<sup>3</sup> A thin section is a slice of rock cut thin enough to be transparent (~0.03 mm), so the mineral and textural characteristics of the rock can be examined using a microscope.

## Exposure

The outcrop of the Hill of Fare pluton is very largely concealed beneath heather moorland and blanket forestry. Natural bedrock exposure in general is sparse and limited to scattered patches of ice-scoured pavement and low crag; however, in places loose boulders provide an indication of the character of the underlying bedrock. The best exposures of fresh bedrock are presented in a dozen or so disused quarries (many of which are flooded) on the south flank of the massif, particularly around Corfeidly, Raemoir and Craigton.

## Geology

The contact between the Hill of Fare pluton and the surrounding rocks is not exposed, but is inferred on BGS geological maps to be the original, intrusive contact with the exception of one short section on the south-east margin of the pluton where a faulted contact is inferred (Figure 10). The simple, smooth outline of the contact, and the fact that in places it cuts directly across undulating ground, suggests it is everywhere very steep or sub-vertical, though the contact may not remain as steep throughout its depth.

The Hill of Fare pluton is emplaced into, and is in contact with, three older geological units (Figure 10).

- All of the south-east margin and most of the west margin of the pluton are in contact with the Crathes Granodiorite Pluton
- The entire north margin is in contact with the Balblair Granodiorite Pluton
- Most of the south margin is in contact with strongly metamorphosed (and in places partly melted) sedimentary rocks of the Dalradian Supergroup (assigned to the Craigievar Formation and Queen's Hill Formation)

A 'metamorphic aureole' approximately 400 metres wide is recorded in the Dalradian rocks bordering the south margin of the Hill of Fare pluton; the aureole represents the zone in which the mineral and textural character of the Dalradian rocks has been changed as a result of the intense heat the rock was subjected to when the hot magma of the Hill of Fare pluton was emplaced.

The geological character of exposed rock in the Hill of Fare pluton can be summarised as follows –

- All of the rock is of 'granite' composition (i.e. there is no other type of igneous rock, such as granodiorite or diorite)
- The main mineral constituents are *quartz*, *alkali feldspar* and *plagioclase feldspar*, which occur in roughly equal proportions and together occupy more than 95% of the rock volume (Figure 11). The remainder is occupied mainly by mica minerals (2-3%; including dark *biotite* mica and silvery *muscovite* mica), *iron-titanium oxide minerals* (~1%), and tiny amounts (<<1%) of the minerals *apatite*, *zircon* and *monazite*; the latter two minerals are likely to be the main repositories of the radiogenic elements uranium and thorium



- Chemical analysis of rock samples from many parts of the Hill of Fare pluton reveal that between 73% and 79% of the granite is silica ( $\text{SiO}_2$ ); this is towards the high end of the range for granite intrusions in general, and the Hill of Fare granite can be said to be compositionally highly evolved
- The granite is texturally variable. In the commonest variant (referred to hereafter as 'main granite') the rock is evenly textured and individual crystals typically are 3-5 mm in size. In many parts of the outcrop the granite is slightly or significantly finer-grained than this, and in some places the bodies of finer-grained rock are of significant size: three discrete, km-scale bodies of relatively fine-grained granite (*microgranite*) are mapped within the Hill of Fare pluton, one roughly in the centre, one close to the west margin and one abutting the south-east margin (Figure 10). In many respects the rock forming these bodies is similar to the main granite, but the rock commonly consists of scattered, relatively large crystals of feldspar and quartz set in a mass of smaller crystals (this association is commonly referred to as *porphyritic microgranite* or *porphyritic aplite*). A small body of very fine-grained granitic-rock (*aplite*) is mapped close to the west contact of the pluton (Figure 10). Microgranite and aplite have been recorded in many localities on Hill of Fare outwith these mapped bodies, suggesting there is significant textural variability in some (perhaps most) parts of the pluton (reflecting a fairly complex history of magma emplacement and cooling). Granite that is coarser-grained than typical main granite ('very coarse-grained granite') has been recorded in a few places
- The boundaries between the main granite and the textural variants are not well exposed, but rare observations suggest that both abrupt and gradational boundaries occur. Veins of microgranite cutting the main granite are reported in places, indicating that the finer-grained variants in general crystallized later. The three mapped bodies of microgranite crop out along a curved, roughly east-west-trending line (Figure 10), but there is otherwise no evidence of any geometric regularity (such as a concentric zoning pattern) in the distribution of textural variants at any scale; it therefore is not possible to predict how they might be distributed in the subsurface
- Fresh samples of the main granite typically are orangeish pink (Figure 11). This colour comes mainly from crystals of alkali feldspar, which suffered mild chemical alteration as the pluton cooled; the alteration produced numerous tiny crystals of secondary minerals, such as clay and iron oxide, within the alkali feldspar crystals, which create the colour
- No fragments of country rock (*xenoliths*) or entrained igneous rock (*enclaves*) have been reported, and there is no evidence that the present erosion level is within, or close to, either the roof zone or the base of the pluton
- The weathering state of exposed granite varies considerably: reasonably fresh granite forms ice-scoured pavements and quarry faces, while completely decomposed granite (essentially sand) underlies slopes and hollows that have not been ice-scoured. Sections of strongly to completely decomposed granite ('gruss') can be up to 2 metres thick

- No geological faults have been reported within the Hill of Fare pluton, and none appear to offset the contact; however, a faulted contact is inferred along one short section of the south-east margin of the pluton (Figure 10)
- No substantial zones of hydrothermally altered granite (such as those that occur in the Cairngorm pluton and the Bennachie pluton; see below) have been reported in the Hill of Fare pluton. However, the paucity of exposure means that this should be viewed more as an absence of evidence rather than as definitive evidence of absence
- There is no topographic evidence (such as steep-sided valleys, prominent cols and deep gullies) that might point to the presence of zones of weak rock. This suggests the pluton does not contain significant zones of chemically altered or strongly fractured rock, at least at the level of present outcrop
- Mineralized joints (veins) appear to be very rare at outcrop; a vein of quartz 50 mm wide on Hill of Corfeidly is recorded on a BGS field slip
- There has been no systematic survey of unmineralized joints in the Hill of Fare pluton (or any part of it), but sparse notes on BGS field slips and observations in quarries on the south flank of the Hill of Fare massif (see Chapter 7) suggest the distribution and character of unmineralized joints is essentially normal/typical compared with similar granite plutons in north-east Scotland. Typically, three sets of unmineralized joints are developed at a single locality, each with a distinct orientation. In any one set, joint spacing typically is on the metre-scale, but this varies locally (creating zones of higher and lower joint density)

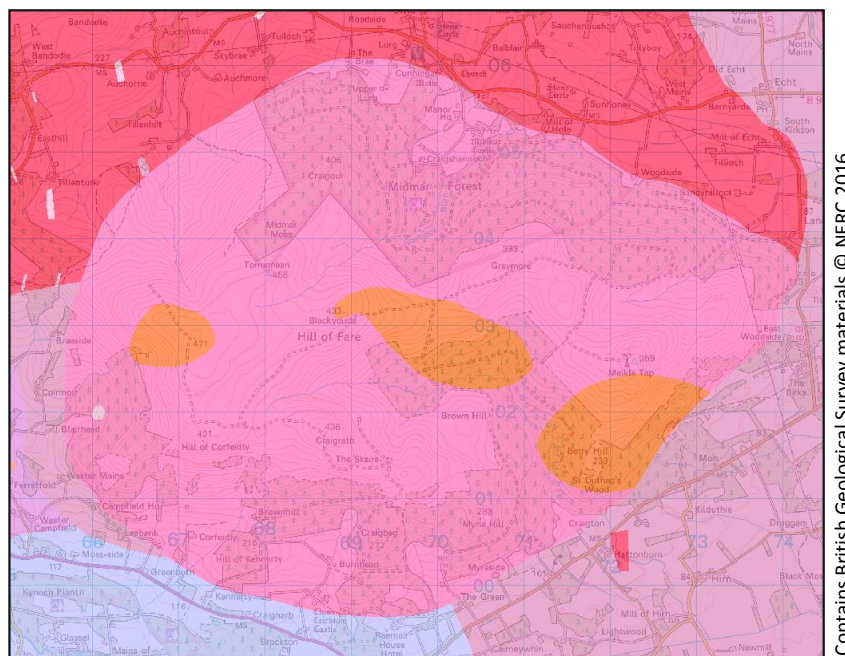

**Figure 10 – Bedrock geology of the Hill of Fare Granite Pluton**

Coloured polygons representing bedrock units from the BGS Digital Geological Map of Great Britain 1:50,000 scale model are superimposed on the OS 1:50,000 scale topographic map (1 km grid squares). The Hill of Fare pluton is the large pink polygon. The three small orange

polygons represent discrete bodies of microgranite mapped within the generally coarser-grained main granite. The very small pale polygon close to the west margin of the Hill of Fare pluton is a discrete body of aplite (very fine-grained granitic-rock). Part of the south-east margin of the pluton is inferred to be faulted where the eastern-most body of microgranite terminates abruptly against it. (See Figure 10 for the names of adjacent bedrock units).

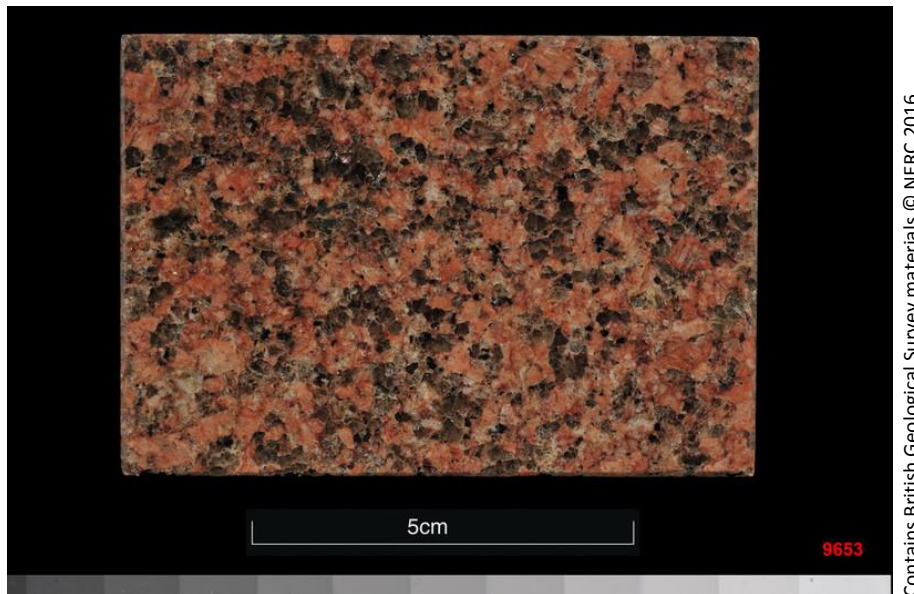
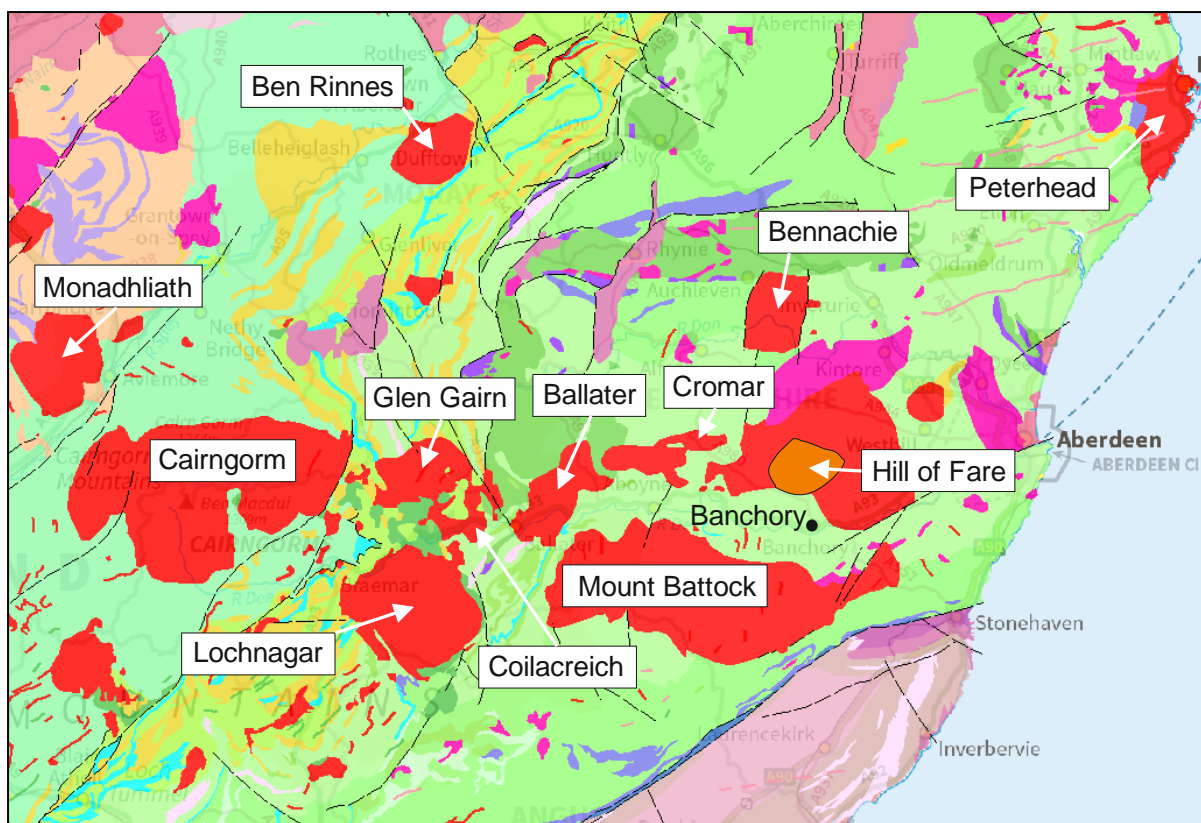

**Figure 11 – Polished surface of a block of Hill of Fare 'main granite'**

The overall orangeish pink colour of this sample is typical of fresh samples of the main granite. Grey crystals are quartz, orangeish pink crystals are alkali feldspar, white crystals are plagioclase feldspar, and black crystals are biotite mica. The sample is from the BGS rock collection (National Building Stone Collection).

### **Insights from other intrusions in north-east Scotland**

The Hill of Fare pluton is generally considered to be a member of the Cairngorm Suite, a discrete 'family' of intrusions within the Caledonian Supersuite that includes a dozen large plutons as well as many smaller intrusions (Figure 12). The individual intrusions of the Cairngorm Suite are inferred to be related genetically because of similarities in their mineral and textural character, chemical composition, age, and topographic expression.



Contains British Geological Survey materials © NERC 2016

**Figure 12 – Location of plutons assigned to the Cairngorm Suite**

Coloured polygons representing generalised bedrock units from the BGS Digital Geological Map of Great Britain 1:625,000 scale model are superimposed on the OS 1:250,000 scale topographic map.

Plutons assigned to the Cairngorm Suite have the following characteristics –

- Most underlie topographically upstanding massifs; the Cairngorm Mountains and the Lochnagar, Ben Rinnes, Bennachie and Hill of Fare massifs are good examples
- They consist entirely of granite *sensu stricto*
- The granite forming several Cairngorm Suite plutons (Cairngorm, Ballater, Bennachie and Mount Battock) has heat production (HP) values above 4  $\mu\text{W}/\text{m}^3$  and therefore is considered to be High Heat Production granite (Gillespie *et al.*, 2013)
- They show considerable textural variability, particularly in grain-size and in the degree to which phenocrysts are developed, and several distinct units of km- to 10-km scale can usually be mapped within individual plutons on the basis of variations in textural character. Typically, the coarser-grained units are the earliest and least compositionally evolved (smaller silica content), and the finer-grained units are the latest and most compositionally evolved (higher silica content). This suggests the magma was emplaced in discrete batches over a period of time (instead of one large, single batch)

- The mappable units within individual plutons usually are arranged irregularly, displaying no organised geometric pattern; the Lochnagar and Ben Rinnes plutons, both of which are concentrically zoned, are exceptions
- The granite commonly is coloured in orangeish to pink tones
- Zones of hydrothermally altered rock are prominent in some intrusions, notably in the Cairngorm and Bennachie intrusions, and to a lesser extent elsewhere

The Hill of Fare pluton is in most respects a typical member of the Cairngorm Suite, though it is relatively small (around one tenth of the area at outcrop of the Cairngorm pluton, and perhaps only one fiftieth of its volume), and apparently lacks prominent zones of hydrothermally altered rock.

Four plutons in the Cairngorm Suite – the Ballater, Bennachie, Cairngorm and Mt Battock plutons – were the focus of detailed investigations during a wide-ranging programme to investigate the geothermal potential of the UK in the late 1970s and early 1980s (details of this programme, and additional references, are in Gillespie *et al.*, 2013). These plutons were selected because of their exceptionally high Heat Production values, and a vertical borehole 300 metres deep was drilled into each one. Unfortunately, the boreholes were not cored continuously: only three short (<7 metre) sections of core were obtained from each borehole, at approximately 100, 200 and 300 metres depth. However, geophysical logs recording a range of rock properties (including rock density, electrical resistivity and natural radioactivity) were obtained over the full length of each borehole. These logs, and the short cored sections, still provide the best information available about the character of Cairngorm Suite plutons in the (relatively shallow) subsurface. The following information, which may be relevant to the present Hill of Fare investigations, comes from a brief review of published details of the geophysical logs and core descriptions (full references are in Gillespie *et al.*, 2013).

- The rock in each borehole is texturally variable to some degree (i.e. none of the boreholes encountered texturally homogeneous granite throughout their length)
  - In the Cairngorm borehole around one third of the rock (all of it in the bottom third of the borehole) is described as “pale red granite, fresh”; around one quarter is described as “possible aplite/pegmatite sheets” (very little of which is in the fresh granite); and the remainder (around half of the borehole) is described as “undifferentiated granite” because “the imprint of alteration makes it difficult to identify rock type”
  - In the Mount Battock borehole around three quarters of the rock is described as “microgranite” and the remainder as “undifferentiated granite or microgranite”
  - In the Ballater borehole around four fifths of the rock is described as “coarse, pinkish-grey granite, fresh” and the remainder as “granite undifferentiated”
  - In the Bennachie borehole around one third of the rock is described as “pinkish-grey granite, mostly fresh”; around one tenth is a single body described as “aplite/pegmatite”; and the remainder was not described

because the “imprint of jointing and alteration obscures variations due to changes in lithology”

- The rock in each borehole displayed considerable variability in the degree to which it was chemically altered and fractured
  - In the Cairngorm borehole less than half the rock is described as “mainly fresh granite”; more than half is described as “slightly altered and/or jointed granite”; and roughly 10% is described as “mildly to severely haematized and jointed”
  - In the Mount Battock borehole less than half the rock is described as “mainly fresh but strongly jointed” and the remainder is described as “severely jointed and possibly partially altered”; in around half of the borehole these two variants occur in alternating bands of 1-metre- to 10-metre scale
  - In the Ballater borehole around two thirds of the rock is described as “fresh granite, some joints”, and most of the remainder as “mildly altered and/or jointed granite”; an interval at least twenty metres long at the bottom of the borehole is described as “severely jointed and/or haematized granite”
  - In the Bennachie borehole around 20% of the rock is described as “mainly fresh rock with some haematization and jointing” and nearly all the remainder is described as “mainly altered, haematized and/or jointed rock”. The top 20 to 30 metres of the borehole is described as “badly caved, especially over the most altered and jointed sections”
- A crude log of the fractures in each cored section revealed the following details; unfortunately the width of joints and veins, and whether or not they contain pore space, is not recorded
  - In the Cairngorm borehole a joint density of approximately 2 joints per metre is recorded in the upper and middle cored sections, and a single haematite-quartz vein is recorded
  - In the Mount Battock borehole a joint density of around three joints per metre is recorded in the upper and lower cores, while the middle core is described as “severely jointed throughout”. Several veins of quartz and hematite are recorded in the upper core, and “intense alteration near joints” is recorded in the lower core. Occurrences of calcite-mineralised veins and calcite-cemented breccia are recorded in both the middle and lower cores, and disseminated pyrite is recorded at one location in the middle core
  - In the Ballater borehole a joint density of around one joint per metre is recorded in the upper core, and only one joint is recorded in the 5.5-metre length of the middle core
  - In the Bennachie borehole a joint density of around three joints per metre is recorded in the upper core. No joints are recorded in the 5.5-metre length of the middle core, but several veins and patches of pegmatite and one “thin jasperoid vein” are recorded

Low heat flow values calculated in all the boreholes led the investigators to infer that the Heat Production capacity of the granite in each pluton must diminish rapidly with depth, but the project found no direct evidence to support this. It is now generally accepted that atmospheric warming since the last glaciation has perturbed the shallowest part of the geothermal gradient and is the main cause of suppressed heat flow values (Westaway and Younger 2013, Busby *et al.* 2015). It therefore remains unclear to what extent the concentrations of radiogenic elements encountered at outcrop in Cairngorm Suite plutons changes with depth.

### Summary of key points

- The Hill of Fare Granite Pluton is a relatively small intrusion of granite that is roughly pear-shaped at outcrop and underlies the Hill of Fare massif, around 5 km north of Banchory. The granite is reported to have moderately elevated concentrations of radiogenic elements at outcrop, raising the possibility that it is, or is close to being, a body of High Heat Production granite and therefore has the potential to provide above-background levels of geothermal energy. The pluton is the main subject of the geological component of this feasibility study because of this geological character and its relative proximity to an established district heating scheme in Banchory.
- The Hill of Fare pluton is considered to be a member of the Cairngorm Suite, a 'family' of granite intrusions that crop out across north-east Scotland and are inferred to be related geologically because they display similarities in their mineral and textural character, chemical composition, age, and topographic expression. The other Cairngorm Suite intrusions, some of which have been characterised in significantly more detail than the Hill of Fare pluton, can to some extent be considered analogues of the Hill of Fare pluton.
- The contact between the Hill of Fare pluton and enclosing rocks is not exposed, but the outcrop pattern of the pluton suggests the contact is very steep to subvertical (at least at, and near to, the outcrop level).
- The depth to which the pluton extends into the subsurface has not been determined but is likely to be at least several kilometres.
- At outcrop the pluton consists entirely of granite (made up very largely of the minerals quartz, alkali feldspar and plagioclase feldspar).
- The granite has a silica content of between 73% and 79%, and is therefore compositionally highly evolved. Moderately elevated concentrations of the radiogenic elements potassium, uranium and thorium (more details in Chapter 8) are consistent with this highly evolved character. The concentrations of silica and radiogenic elements are likely to decrease with depth, but currently there is no evidence (in the Hill of Fare pluton or other plutons of the Cairngorm Suite) to indicate how rapidly such changes might occur. There is also no evidence to suggest that igneous rocks other than granite would be encountered within the depth range of interest to a geothermal project (i.e. down to ~5 km).

- At outcrop the granite is texturally variable at the 10-metre to km-scale. Three discrete, km-scale bodies of microgranite have been mapped within the pluton; these crop out along a curved, roughly east-west-trending line. There is otherwise no evidence of any geometric regularity in the distribution of textural variants at any scale; it therefore is not possible to predict how they might be distributed in the subsurface.
- Based on the evidence described above it is reasonable to assume that a borehole drilled vertically to a depth of up to several kilometres anywhere in the Hill of Fare pluton would encounter only granite, but the granite is likely to exhibit textural variability on a range of scales and may exhibit a measurable decrease in the concentration of radiogenic elements (and therefore Heat Production capacity) with depth.
- The success of a geothermal energy scheme in the Hill of Fare pluton (and in any other body of granite) depends on the borehole(s) intersecting one or more fractures at depth that form part of a network of connected, permeable fractures. There are two ways in which a network of connected, permeable fractures can form naturally in a body of granite: (i) as a direct result of rock rupturing in response to Earth movements (e.g. displacement on a geological fault); (ii) as a result of the dissolution of soluble minerals in veins due to a change in groundwater conditions. These two processes can operate together, for example when Earth movements create new cracks in pre-existing calcite veins, allowing groundwater to come into contact with, and perhaps dissolve, the calcite.
- No geological faults have been recorded within the Hill of Fare pluton, and few have been observed or inferred in the ground surrounding the pluton or in other intrusions of the Cairngorm Suite. It therefore seems unlikely that a borehole through the Hill of Fare pluton would intersect a sizeable fault or fault-zone, though this remains a possibility.
- No major zones of strongly altered rock have been recorded within the Hill of Fare pluton, and there are no topographic features that might point to the presence of zones of weak rock. This suggests the pluton does not contain significant zones of chemically altered or strongly fractured rock, at least at the level of present outcrop. It therefore seems unlikely that a borehole through the Hill of Fare pluton would intersect a major fracture zone, or a major zone of altered rock, though this remains a possibility.
- The distribution and character of unmineralized joints on the outcrop of the Hill of Fare pluton is essentially normal / typical when compared with similar granite plutons in north-east Scotland. However, unmineralized joints develop in the near-surface zone of all granite intrusions as they are uplifted in Earth's crust (because the brittle rock expands and cracks as the overlying rock is removed), and they provide little direct evidence of the character of the fracture network at depth.
- Very few mineralized joints (veins) have been recorded at outcrop in the Hill of Fare pluton; those that have been recorded have fillings of quartz and, locally, hematite (an iron oxide mineral). Calcite, a common fracture-filling mineral, has not been recorded in joints on the outcrop of the Hill of Fare pluton; however, calcite is soluble in near-surface groundwater and may be present in fractures below the near-surface zone.
- The evidence from 300 metre-deep boreholes drilled into several other Cairngorm Suite plutons suggests: a 'background' joint density of up to 3 joints per metre may be typical in Cairngorm Suite plutons, at least in the shallowest few hundred metres; zones of



hydrothermally altered (and locally densely fractured) rock can be encountered to a depth of at least 300 metres; calcite-filled fractures and calcite-cemented breccia are present locally. The latter point raises the possibility that a network of fractures made permeable by calcite dissolution may exist at depth in the Hill of Fare pluton.

- A test borehole will be needed to provide a more robust understanding of the geology at Hill of Fare and thereby reduce the risk attached to some of the geological uncertainties of a geothermal energy project here. The borehole, ideally drilled to a depth of around five hundred metres (which should be well below the influence of weathering), could be used to: measure heat flow in the borehole and changes in heat production capacity with depth; record changes in rock texture, rock weathering/alteration condition, and thermal conductivity with depth; determine the character and distribution of permeable fractures and other discontinuities; measure the temperature, composition and flow-rate of water in permeable features.
- Boreholes for a geothermal energy project probably should be drilled at least 2-300 metres from the edge of the pluton due to uncertainty over the position of the contact at depth, and the possibility that there is a 'contact zone' within which the character of the rock mass changes and/or is unpredictable.

## 5. Provisional Borehole Design

A future geothermal system serving Hill of Banchory will require a minimum of two deep boreholes – one for abstraction, the other for reinjection. As it is advantageous to be able to reverse the polarity of the system to combat clogging in reinjection boreholes, the basic design for both boreholes will be the same. The outline design presented here is based on direct experience over the last dozen years in the drilling of deep geothermal boreholes in northern England (see Manning *et al.* 2007), informed by wider insights from the geothermal sector worldwide.

Deep geothermal boreholes are essentially extremely deep water wells, and their design follows the same principles as commonplace shallow water wells, in that:

- The borehole must be engineered to stand open, without ingress of unwanted fine particles etc., and
- In the zone from which water production is desired, any means of holding the borehole open must allow for ingress of groundwater, while still preventing ingress of fine particles etc.

The key to achieving these two requirements is an effective borehole lining system, in which ‘casing’ (i.e. unperforated steel pipe) is installed from surface to the upper limit of the targeted production zone, with ‘screen’ (i.e. perforated pipe) being installed below, throughout the intended production zone. Where a rock is very strong (as is the case with granite) the screen may be dispensed with; this was done, for instance at Eastgate in Weardale, and the well was found to be standing open 6 years later without any problem. Dispensing with long runs of pipework saves on both costs and embedded carbon emissions, but a final decision on that can only be taken when the behaviour of the rock during drilling has been assessed in detail. Precautionary screening of deep sections can be achieved at lower cost (and lower notional emission) by re-using casing that has been remaindered from the offshore hydrocarbon industry.

Borehole lining requires that the installed casing be fixed in place to prevent unwanted migration of fluid outside the open lumen of the borehole. To this end, the annulus between casing and drilled borehole wall is typically plugged with ‘grout’, which may be a simple Portland cement or some more elaborate composite, e.g. including bentonite as an aid to impermeabilisation. In geothermal wells, a simple cement grout usually suffices, as this performs well at elevated temperatures, actually increasing in strength with temperature. A further feature of geothermal wells is that cement is typically installed through the full length of the cased zone (in the hydrocarbon sector, sometimes only a limited interval of a few hundred metres may be fully cemented). This is because the anticipated differential thermal expansion of steel casing and cement grout is best managed by minimising accommodation space; full grouting of successive concentric casings also serves a useful insulation purpose.

Of course, as the screened section must be open to allow water to enter the borehole, no cement is installed in the annulus between the screen and the borehole wall; this is either left empty (most common in geothermal boreholes) or else packed with a coarse, permeable sand / gravel filter pack. Design of a borehole essentially proceeds from bottom-up: the first thing to establish is the final screened diameter. A common choice is to select a standard steel pipe diameter of 9 5/8" (note that borehole components are still quoted in old units, because of US dominance of the sector). This in turn means that the drilled hole needs to be wide enough to receive pipe of this diameter; a 12" drilled diameter should usually provide enough clearance. This screened section is normally flush jointed (screw fit) continuously to join the run of unperforated pipe above the production zone all the way to surface, forming the pipe through which geothermal fluid will be induced to flow by pumping at a higher level. This innermost, narrowest string of pipe (perforated near the base, unperforated above) is often termed the "production casing". Depending on the characteristics of the overburden, one or more outer (larger diameter) casings may also be required, to exclude from the borehole any caving or fines-releasing strata. The number and diameter of such casings would depend on whether future boreholes at Banchory were commenced on the granite outcrop, or on adjoining Dalradian outcrop. If the borehole commences on granite, then a single outer casing might be all that is required, from surface down to about 20 – 30m until the hole is well established in sound granite. To allow for response to unanticipated conditions, this 'surface casing' is usually drilled and lined at a generously large diameter (the short length means that the costs are not excessive despite this). Drilling at 26" and casing at 20" is anticipated, and this would be fully cemented back to surface. If starting on the Dalradian, a secondary casing run would also be installed to prevent ingress of fine particulates (e.g. muscovite grains). This would typically be drilled at 17 1/2" and lined with casing of 13 3/8", again cemented to surface. The production casing would then be drilled at 12", as already explained, and completed at 9 5/8". It is also possible to extend the productive zone by adding a narrower (e.g. 7") lower section to the hole, intersecting more fractures at higher temperature without committing to the full costs of completing at 9 5/8". Some of these options are summarised on Figure 13. What is not shown on the Figure is the possibility that the lower zones of the borehole be directionally drilled, to access the granite from a remote site starting on Dalradian outcrop, and / or to maximise intersections of sub-vertical fractures oriented favourably in relation to the local maximum compressive crustal stress azimuth to maximise the likelihood of tapping sufficient permeability. This detail would need to be established during a future project (see Chapter 19).

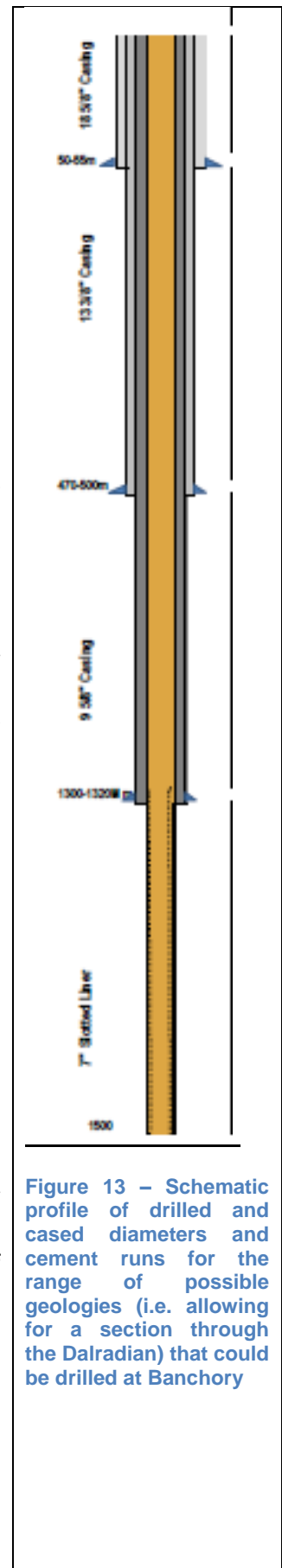

Figure 13 – Schematic profile of drilled and cased diameters and cement runs for the range of possible geologies (i.e. allowing for a section through the Dalradian) that could be drilled at Banchory

Image: Cluff Geothermal

While it is typical for oil wells at these depths to be drilled using downhole motors and polycrystalline diamond compact (PDC) bits, the high strength of granite typically demands use of special tri-cone 'rock-roller' bits and / or down-the-hole hammer, actuated either by compressed air or water. In granite, we can normally achieve adequate flushing of cuttings from the hole with air, water or foam, rather than the bentonite mud suspensions favoured in the hydrocarbon industry, thus avoiding the risk of clogging permeable fractures with mud cake.

Although drilling in granite is slower than in sedimentary strata, casing is generally swifter, so that the overall programme is not greatly attenuated. An indicative programme of about 6 weeks per well would be anticipated, allowing for preparation of the site (installing any liner required by SEPA, plus a hard core platform to receive the rig. The drilling compound would be enclosed with fencing to prevent casual access by livestock or passers-by.

## 6. Expanding the database: additional survey work on the Hill of Fare granite

Although the existing data for the region have provided the bulk of the evidence used to develop this analysis, the lifetime of the feasibility project provided an opportunity to collect some more detailed site-specific data for the Hill of Fare pluton, to help constrain geothermal resource estimates. Results of this survey work are summarised in this chapter.

### 6.1. Heat Production

#### What is heat production?

Heat production is the heat energy produced in each cubic metre of rock due to radioactive decay of naturally occurring radio-elements. Many granites, such as the Hill of Fare Pluton, have elevated concentrations of uranium (U) and thorium (Th) compared to other rocks, as well as a significant component of potassium (K). These elements have radioactive isotopes which produce heat during decay. If present in large enough quantities then the heat produced by the decay of K, U, and Th can significantly elevate the geothermal gradient making higher temperatures accessible at shallower depths.

The heat production rate of the Hill of Fare has previously been estimated at  $3.9\mu\text{W}/\text{m}^3$  (Downing and Gray 1986). However only two samples were used to make this estimate; as such there would be significant risk when using this value for predicting the geothermal gradient of the Hill of Fare granite. We conducted a new survey of the Hill of Fare granite to produce a robust value of heat production.

#### Method

##### *Field Methods*

The method used in this study is consistent with that shown in McCay *et al.* (2014). That paper also provides a comprehensive but accessible introduction to gamma-ray spectrometry in geothermal exploration.

A hand held portable gamma-ray spectrometer was used to measure concentrations of K(wt%), U (ppm), and Th (ppm.) The equipment used was a GSII model spectrometer produced by GF instruments in Brno, Czech Republic. This model of spectrometer automatically produces concentration of K, U, and Th without the need for calibration or manual calculation.

To take a measurement the gamma-ray spectrometer is placed onto the rock and held there for several minutes. In this study, each measurement lasted five minutes as this has been found to be a sufficient trade-off between accuracy and speed when using a GSII on such moderately radioactive granites. Measurements were repeated until two consistent values were found. Consistent readings were judged as being less than 1ppm difference in uranium or 10nGy/hr difference in total dose rate.

Measurement locations are ideally flat surfaces with good rock exposure. This minimises any over or under-estimation that may affect the results, due to local topography, vegetation cover, or preferential erosion of grains that contain K, U, or Th. The Hill of Fare granite is poorly exposed and highly weathered in most locations. As such, most measurement locations were either likely underestimates or overestimates of the true concentrations of K, U, and Th; the following section outlines how these were dealt with.

### ***Data Processing***

In total 38 sample locations were measured of the Hill of Fare granite, 3 of the microgranites within the Hill of Fare, and 6 measurements of the surrounding Crathes granite. At least two consistent measurements were collected at each sample location. When just two measurements were taken then the first of these was used for the representative K, U, and Th concentrations. If three or more measurements were taken then the middle value was used.

Many sample locations were taken from abandoned quarries which are located around the Hill of Fare granite. These quarries have the advantage of being relatively fresh faces so have not undergone erosion to the same degree as natural exposures. However 10 of these sample locations had the disadvantage that the nearby quarry walls and ledges created overestimated results. There are no standard methods detailed in the gamma-ray spectrometry literature to deal with such problems, so a novel solution is proposed here. K% is often the most consistent of the three radio-elements across granites and it is the change in U and Th concentrations that generally determine higher and lower heat production zones. K is typically between 3.8 and 4.5% in granite intrusions of the Cairngorm Suite. However K% values in the quarries were consistently higher than this indicating that they are likely overestimates due to the other quarry walls and surfaces. This was tested by taking a reading in the corner of a quarry wall which should lead to an overestimation by 50%. The K% value from this test was 7.14 which is 58% higher than an assumed reasonable value of 4.5. This test shows that the assumption of using K% as an indicator of overestimation is reasonably sound. Therefore, all the heat production values taken from the quarries have been lowered by the ratio that their K% estimate is higher than 4.5.

Nine values have not been used for the Hill of Fare granite because they were identified as likely underestimates. This underestimation results from topography of the rock or partially exposed rock surfaces where it isn't clear if we are sampling bedrock or a large boulder. Due to the small number of measurements in the micro-granite and Hill of Fare granites all of these values were used to estimate heat production of those units.

The following equation was used to calculate the heat production value of each of the measurements of K, U, and Th:

$$HP = \rho\{(0.035C_K)+(0.097C_U)+(0.026C_{Th})\}$$

Where  $\rho$  is the granite density in ( $\text{kg m}^{-3}$ )  $C_K$  is concentration of potassium by % weight, and  $C_U$  and  $C_{Th}$  are concentrations of uranium and thorium in parts per million.

## Data and Results

The raw data are contained within Appendix 4, which also explains which samples were used to calculate the averages shown below, and which samples were discarded due to underestimation errors, or else corrected for overestimation.

Sample Location	Mean Heat Production ( $\mu\text{W}/\text{m}^3$ )
Hill of Fare Granite	4.04
Hill of Fare Microgranite	3.13
Crathes Granodiorite	2.09

**Table 1 – Heat Production Values for the Hill of Fare Granite, Hill of Fare Microgranite and the neighbouring Crathes Granodiorite**

The average value of  $4.04\mu\text{W}/\text{m}^3$  is slightly higher than the previous estimate of  $3.9\mu\text{W}/\text{m}^3$ , however the new value is taken from 29 samples across the Hill of Fare granite so is much more robust than the earlier figure. The Hill of Fare granite has a lower heat production compared with other high heat production granites in the East Grampians, i.e. Cairngorm (7.3), Ballater (6.8), Mount Battock (4.8), and Bennachie (7.0), however the heat production of Hill of Fare is significantly higher than several other granites (e.g. Crathes Pluton (2.09) or Aberdeen granite (2.2)) and the surrounding Dalradian metasedimentary rocks.

## 6.2. Temperature Projections

The method used for predicting subsurface temperatures in the granites is consistent with previous geothermal studies into the East Grampian granites (e.g. Downing and Gray (1986)). The use of consistent methods allows direct comparison between the Hill of Fare and the other granite bodies of the East Grampians, as well as to radiothermal granites elsewhere. These predictions have also been tested against other methods for predicting subsurface temperatures to add robustness and confidence in the predictions; these other methods are discussed in Westaway and Younger (2013).

The following equation has been used for the temperature predictions.

$$T_z = a' \exp[(q_0 z - f(z))/a' \lambda_0] - b'$$

Where:  $T_z$  is the temperature at a given depth ( $^{\circ}\text{C}$ ),  $q_0$  is surface heat flow ( $\text{mW}/\text{m}^2$ ),  $z$  is depth (m),  $\lambda_0$  is surface thermal conductivity ( $\text{W}/\text{m}/\text{k}$ ).  $b'$  is a constant of 823.33 and  $a' = b' - \theta_g$  where  $\theta_g$  is mean surface temperature which is taken here at  $7.5^{\circ}\text{C}$ .

The function of  $f(z)$  depends on whether the heat production of the granite is assumed to decline exponentially or linearly.

When heat production is assumed to decline exponentially the function is:

$$f(z) = A_0 D [z - D(1 - \exp(-z/D))]$$

When heat production is assumed to decline linearly the function is:

$$F(z) = [(A_0z^2)/2] - [(uz^3)/6]$$

Where  $A_0$  is surface heat production ( $\mu\text{W}/\text{m}^3$ ) and  $u$  is a constant with the value of 0.3.

These predictions provide a one dimensional heat profile. However the granite will be a complicated three dimensional structure. In reality, areas such as the microgranite with lower thermal conductivity will create a more complicated temperature profile.

The key inputs to the temperature equation are heat flow, heat production and the thermal conductivity. The new robust estimates of heat flow and thermal conductivity (see section 6.3) will be used as inputs. However heat flow is best estimated from temperature data in boreholes several hundred metres deep, preferably 500m – 1 km deep. Lack of suitable boreholes meant that this could not be done during the present project. Fortunately, four neighbouring high heat production granites have previously had heat flow boreholes drilled as part of the original East Grampian geothermal exploration in the 1980s. The four heat flow boreholes were drilled in the Cairngorm, Bennachie, Ballater, and Mount Battock granites. As previously noted, heat flow estimates in these boreholes were found to be surprisingly low. However, it is now clear that these low values were due to routine corrections to palaeo-climate not being applied. Two recent publications have added the palaeo-climate corrections. Westaway and Younger (2013) corrected the Ballater borehole as part of a wider study of the UK's heat flow as well as applying a new topographical correction. Additionally, Busby et al. (2015) applied corrections to all four East Grampian boreholes and significantly upgraded the heat flow estimates. We have also applied the methods of Westaway and Younger (2013) to the Cairngorm, Bennachie, and Ballater granites (Table 2) to independently verify the corrected results presented by Busby *et al.* (2015). The relatively close correspondence of these two recent suites of estimates is highly encouraging.

Granite	Original heat flow estimates (Downing and Gray 1986) ( $\text{mW}/\text{m}^2$ )	Busby <i>et al</i> (2015) heat flow estimates ( $\text{mW}/\text{m}^2$ )	New Heat flow estimates using the method of Westaway and Younger (2013) ( $\text{mW}/\text{m}^2$ )
Cairngorm	69.5	88.9	95
Bennachie	75.8	89.9	87
Ballater	71.4	87.8	89.5*
Mount Battock	58.7	76.3	87

**Table 2 – Heat Flow Estimates of the High Heat Production East Grampian Granites**

The Hill of Fare granite is in the same suite as these four high heat-producing granites and is geochemically similar. Therefore we can expect the heat flow in the Hill of Fare granite to at least be similar to that of the other four HHP granites, so that we can use these heat flow values to guide the Hill of Fare temperatures prediction.



Scenario	Heat Flow (mW/m <sup>2</sup> )	Heat Production (μW/m <sup>3</sup> )	Thermal Conductivity (W/m/k)
Most favourable	90	4.5	3.00
Intermediate	85	4.04	3.16
Pessimistic	75	3.6	3.33

Table 3 – Heat Flow, Heat Production and Thermal Conductivity Estimates for Hill of Fare Granite

Table 3 shows the values that have gone into creating the three downhole temperature scenarios for the Hill of Fare granite. The intermediate scenario for heat production and thermal conductivity was selected as the baseline for this project. The ‘most favourable’ scenario was calculated by using the best estimate of heat production from measured values, increased by double the standard error of the mean. The ‘pessimistic’ scenario for heat production used the same best estimate, this time reduced by double the standard error of the mean. (For the thermal conductivity the favourable and unfavourable scenarios were developed by lowering and raising the maximum density Gaussian kernel by 5%, which is a reasonable range for this relatively invariant parameter). Each of these scenarios was also modelled with two assumptions relating to the decline of heat production with depth, as outlined above (i.e. exponential and linear).

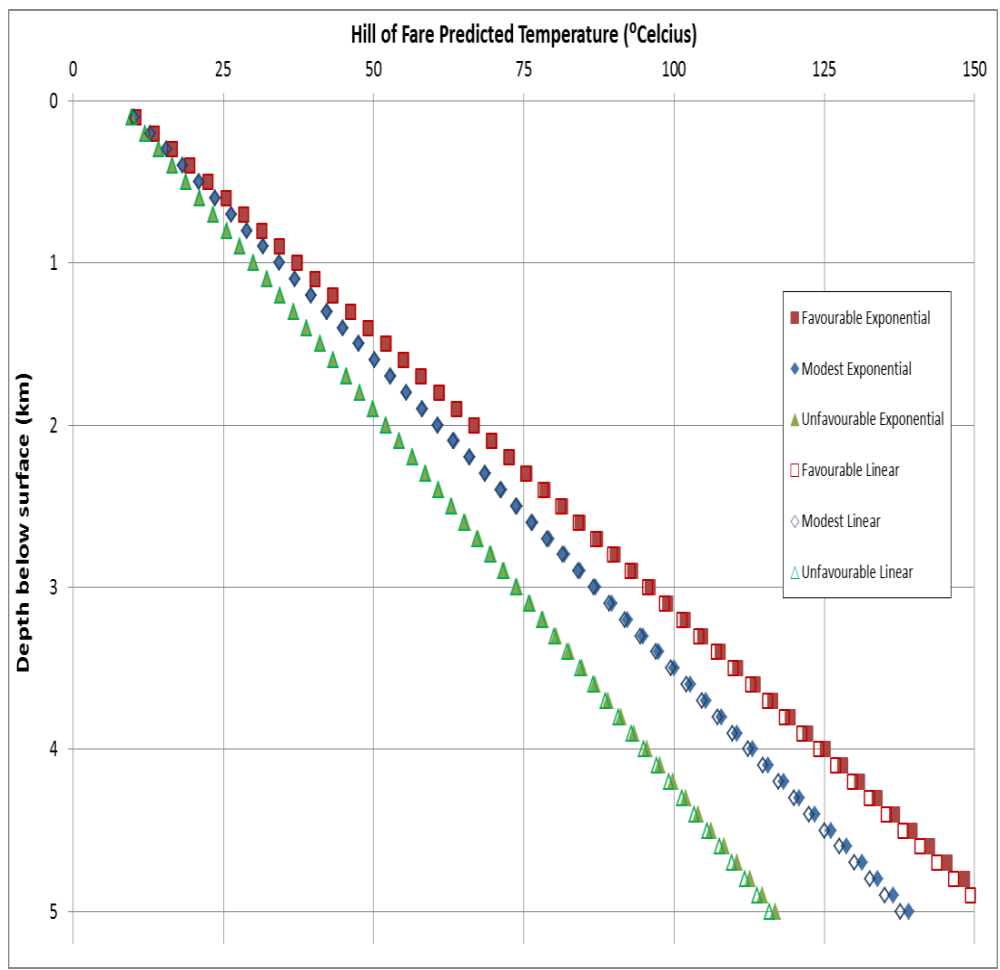

Figure 14 – Geothermal Gradient Prediction Scenarios for Hill of Fare Granite

Figure 14 shows the predicted temperatures for both heat production assumptions for each of the three scenarios. The heat production assumptions do not seem to make a significant difference down to 5km depth. The favourable scenario has a geothermal gradient of 29.0°C/km, the modest scenario of 25.9°C/km, and the unfavourable scenario of 21.1°C/km. At 3km depth there is already a 22°C difference between the favourable and unfavourable scenarios.

Table 4 indicates the depth each scenario predicts for two possible target temperatures for a heat only geothermal scheme. For a 90°C temperature to be reached in the granite there will be a 1km difference in target depths between the favourable and unfavourable scenarios. Even for the 75°C temperature the difference remains large at 0.8km. Generally, the difference in depths between the favourable and unfavourable scenarios means that drilling will be around 30% deeper for the unfavourable scenario for a specific targeted temperature.

Target Temperature (°C)	Depth to target temperature (km)		
	Favourable	Modest	Unfavourable
75	2.2	2.4	2.9
90	2.8	3.2	3.8

Table 4 – Depth to Typical Target Temperatures

### 6.3. Thermal Conductivity

Calculation of heat flow requires knowledge of the thermal conductivity of the rocks. Thermal conductivity is a material's capacity to conduct or transmit heat and is measured in W/mK. Being rich in quartz (the most thermally conductive of the common rock forming minerals), granites are usually good heat conductors. However, site-specific data for the Hill of Fare Granite were not available, so 18 plug samples from the Hill of Fare Granite were analysed using a Portable Electronic Divided Bar.

#### Methods

##### **Sample Collection**

The 18 samples were collected from the Hill of Fare granite and microgranite at three key localities. They were collected using a handheld 1-inch diameter diamond-edged plug drill. Full details of the samples are listed in Appendix 1.

##### **Sample Preparation**

The drill core samples (roughly 24mm in diameter) were cut into roughly 1 cm thick slices. During the rock sawing process some of the samples chipped along the edges, most commonly due to pre-existing fractures within the core. These features are noted in Appendix 1.

Sample preparation was an important part of the process as irregularities along the sample / plate contact can impede the heat flow across the sample and can produce lower thermal conductivity values. These irregularities can come in the form of grooved sample faces from the rock sawing process, chips along the edges of the samples, and fractures within the samples. To create the best sample/plate contact they underwent two polishing processes. First, both faces and the edges of each sample were smoothed using grinding wheels of roughness 175 and 40. Another round of polishing was then completed using 300 grit.

### ***Thermal Conductivity Analysis***

Data were gathered using a Portable Electronic Divided Bar, which produces a temperature gradient across rock samples and allows thermal conductivity of the samples to be calculated using Fourier's Law.

Once the samples had been prepared the top and bottom faces were coated in petroleum jelly to facilitate good thermal contact. They were then clamped into the divided bar until the sample equilibrated.  $\Delta T$  (a unitless software calculated parameter) versus time was graphed using a Pico Logger coupled with the divided bar, allowing us to visualise when the sample had equilibrated. Thermal conductivity values were then calculated by inputting sample thickness, sample surface area, sample diameter and  $\Delta T$  at equilibrium into the master spreadsheet. The following equation was used;

$$\text{Thermal Conductivity} = d/R$$

$$R = (A (\Delta T - c)) / (a (\text{diameter} + b))$$

$$A = \text{surface area of sample in mm}^2$$

$$D = \text{diameter of sample in mm}$$

$$a, b, c = \text{calibration constants}$$

Standards were run every two samples. The standards, provided by HDR, were gabbro, sericite and granodiorite. Readings from these samples during this project were combined with measurements of the standards taken over the lifetime of the instrument. This allowed us to produce "lifetime corrected" thermal conductivity values.

The granites were put into the divided bar with the outermost surface facing up. This was done to allow for future research into whether conductivity values vary when heat flows in different directions through the rock.

Each sample was run three times to increase confidence in calculating an accurate average and to highlight anomalies.

## Results

Table 5 details lifetime corrected K values.

### **Lifetime Corrected K (W/mK) Summary**

<i>HoF#</i>	Run 1	Run 2	Run 3	Average
1	3.21	3.22	3.42	3.284
2	3.27	3.26	2.46	2.995
3	3.12	3.10	3.41	3.213
4	2.24	2.24	2.56	2.349
5	2.81	2.82	2.77	2.803
6	2.92	2.94	3.15	3.004
7	2.92	2.90	3.04	2.955
8	2.74	2.71	2.65	2.697
9	3.08	3.06	3.26	3.133
10	2.57	2.56	2.67	2.601
11	3.05	3.03	3.14	3.072
12	3.23	3.21	3.33	3.256
13	3.33	3.32	3.39	3.346
14	3.33	3.30	3.21	3.279
15	3.11	3.10	3.00	3.071
16	2.04	2.02	2.46	2.176
17	3.54	3.53	3.97	3.682
18	3.19	3.15	3.58	3.305

**Table 5 – Lifetime Corrected K Values**

Univariate statistics were deemed inappropriate for this type of data due to the number of variables, so it was fitted to a Kernel Density Estimator (KDE). Results show that the data show maximum likelihood at a thermal conductivity value of 3.16 W/mK.

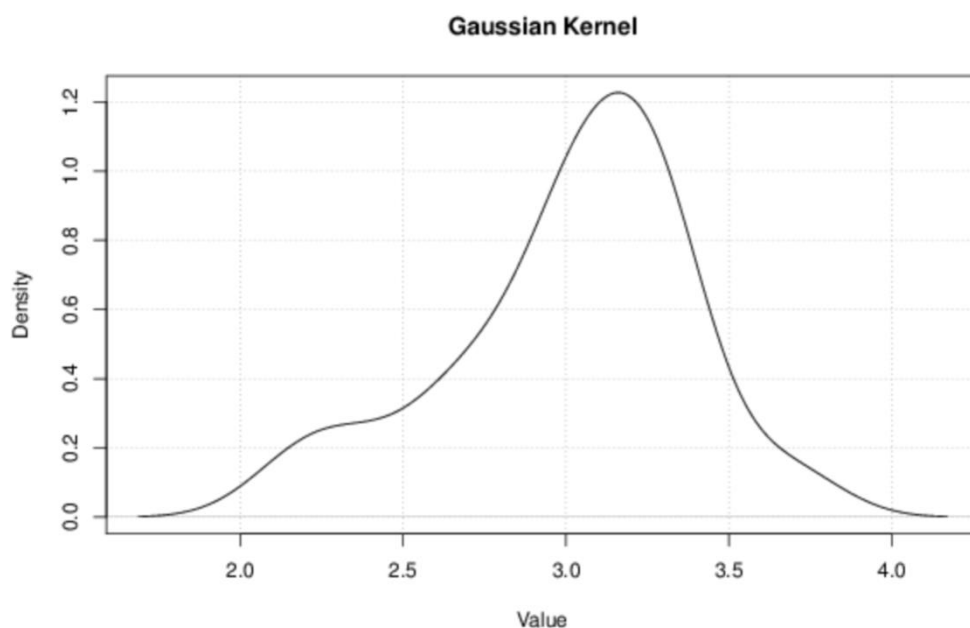

Maximum Density Values		
Kernel	x-value	max. density
Gaussian	3.15982290440919	1.22653381480463
Epanechnikov	3.13066632701014	1.20780760172049
Rectangular	3.06749374264552	1.28015339460947
Triangular	3.13066632701014	1.18777393210336
Biweight	3.14524461570967	1.21343058487015
Cosine	3.15010404527618	1.21435773999112
Optcosine	3.14038518614316	1.20856835859716

Figure 15 – Estimated thermal conductivity, Hill of Fare

This statistical analysis was carried out by using the following online software - [http://www.wessa.net/rwasp\\_density.wasp](http://www.wessa.net/rwasp_density.wasp).

## Discussion

Average thermal conductivity values for the Hill of Fare Granites range between 2.176 and 3.682 W/mK, which is consistent with the range of 2.9 and 3.6 W/mK given for other High Heat Production Granites (HHP) in Scotland in the Scottish Government paper ‘Study into the Potential for Deep Geothermal Energy in Scotland’ (Gillespie et al. 2013).

The highest, most consistent results were found amongst the Craighton Main Quarry samples, which yielded values that were consistently above 3 W/mK.

The lowest results were found in the Raemoir North Quarry samples with values consistently at or below 3 W/mK.

No real correlation was seen between thickness and thermal conductivity. Chips, tapers and other minor irregularities in the samples also didn't seem to have a noticeable impact on the results.

The third round of readings show, in general, slightly higher values than the first two. However, within the set they show relatively similar patterns to the first two sets. This systematic discrepancy may have arisen as a result of the laboratory being of a significantly lower temperature than when the first two sets were run. The effect of room temperature on readings given by the Divided Bar is now being interrogated by Town Rock Energy and the University of St Andrews, where the tool is held. For the purpose of this study, the effects on the results are negligible and within the 5% degree of uncertainty.

## 6.4. Gravity and Magnetic Surveying

### Background

Potential field methods are geophysical methods that use variations in the Earth's gravity and magnetic fields ("anomalies" – differences in what are measured from some reference value) to infer variations in the geometry and properties of rocks below the surface that are not otherwise directly observable (as in outcrop geology). In the case of gravity and magnetic methods the rock properties that vary are density and magnetic susceptibility respectively. Regional gravity and magnetic anomalies for an area of north eastern Scotland centred on the Hill of Fare pluton are shown in Figure 16.

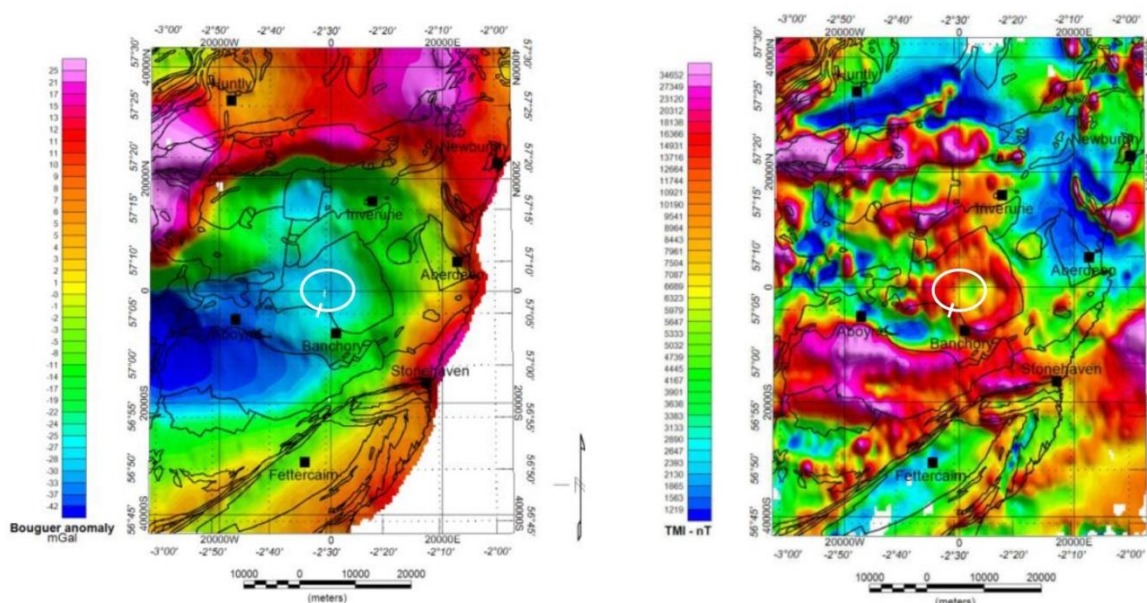

Contains British Geological Survey materials © NERC 2016

**Figure 16 - (a) Regional Gravity [left-side image], (b) Magnetic Anomalies [right-side image] for a part of north-eastern Scotland (BGS Data (2002))**

Figure 16 is based on measurements approximately one per 2 km<sup>2</sup> (BGS, 2002), which gives an indication of its resolving capability. The magnetic map is compiled from aeromagnetic data observed on E-W flight lines with 2 km spacing. The location of the Hill of Fare pluton is schematically indicated by the white ellipse and the white tick mark the location of the local gravity and magnetic surveys carried out as part of this project.

Figure 16 demonstrates that the gravity and magnetic fields of north-eastern Scotland correlate to a large degree with the distribution of igneous plutons (cf. McGregor and Wilson, 1967; Johnston, 2015). Gravity anomalies associated with the Hill of Fare pluton are generally less than surrounding areas and magnetic anomalies generally greater; the latter is most evident although in both cases, for the low resolution, regional data available, any singular Hill of Fare anomaly coalesces with those sourced from surrounding igneous (and possibly other geological) bodies.

Bulk density of upper crustal rocks varies in the approximate range 2,000-3,000 kgm<sup>-3</sup>. This depends on the constituent minerals of rocks with common rock-forming minerals that are “light-coloured” (quartz, white and pink feldspars such as those that dominate in “felsic” rocks like granites) being less dense than minerals that are “dark-coloured” (amphibole, pyroxene, grey and black feldspars such as found in “mafic” rocks like basalt and amphibolite) are denser. A typical density for the Hill of Fare granite (“biotite granite, pink, leucocratic”; BGS, 2002) would be in the range 2,600-2,700 kgm<sup>-3</sup> and according to measurements made by McGregor and Wilson (1967) it is 2,630 kgm<sup>-3</sup>. The country rocks to the south of the Hill of Fare granite are “psammitic” and “pelitic” (metamorphosed sandstones and shales) metasedimentary rocks of the Argyll Group (BGS, 2002) and such rocks are likely characterised by higher density than the granite of the Hill of Fare; a value of 2,740 kgm<sup>-3</sup> is reported by McGregor and Wilson (1967) for the Dalradian Supergroup, of which the Argyll Group forms one subdivision. Accordingly, the Hill of Fare granite (and associated igneous plutons) should display negative gravity anomalies relative to surrounding areas as is the case in Figure 16.

Bulk magnetic susceptibility of upper crustal rocks lies in the range 0-0.2 (SI units) and depends on the presence of magnetic minerals such as, especially, magnetite. Magnetite is generally most prevalent in dark-coloured mafic crystalline rocks, less so in light-coloured crystalline felsic rocks and relatively uncommon in (meta) sedimentary rocks. According to McGregor and Wilson (1967) suitable values of magnetic susceptibility are 0.025 (SI units) for Hill of Fare granite and nil or very small for Dalradian strata. Accordingly, the Hill of Fare granite (and associated igneous plutons) should display positive magnetic anomalies relative to surrounding areas as is the case in Figure 16.

## **Objectives**

The project activity was a small-scale pilot survey aimed at testing whether high resolution (tightly-spaced) gravity and magnetic field measurements along a profile crossing the geologically inferred boundary of the Hill of Fare granite pluton and Dalradian country rocks would be capable of pinpointing its location exactly, possibly with inferences about its subsurface geometry (e.g. dip direction, thickness). The results were expected to provide an indication of whether density and/or susceptibility contrasts would be sufficient for delineation of this boundary in three dimensions from high resolution gravity and magnetics surveying on a two dimensional grid in an area of specific interest such as a potential future geothermal well site.

## Data acquisition, reduction and results

The scope of the work and logistical considerations dictated that surveying was limited to several days in the field and at one locality with good road access crossing the inferred Hill of Fare granite-country rock contact. Figure 17 shows the chosen location of the surveying, which took place on the southern slopes of the Hill of Fare on and near the Burnhead Farm road off highway A980 just north and west of the Raemoir House Hotel.

Figure 17 shows the location of the observed gravity and magnetic profiles. Gravity observations were made on 21-23 January 2016 using a Scintrex CG-5 “Autograv” gravity meter. The instrument is extremely sensitive to levelling and therefore ground stability. For this reason measurements were made as much as possible along hard roadbed or other surfaces. Measurements in fields was also possible though more time-consuming, by reinforcing the ground surface with harder materials before measuring. Some 40 stations were observed as shown in Figure 18. Weather conditions prevented measurements being made in the later part of the afternoon of 21 January and all of the morning of 22 January. Suitable daylight was available from about 9 am until 4 pm.

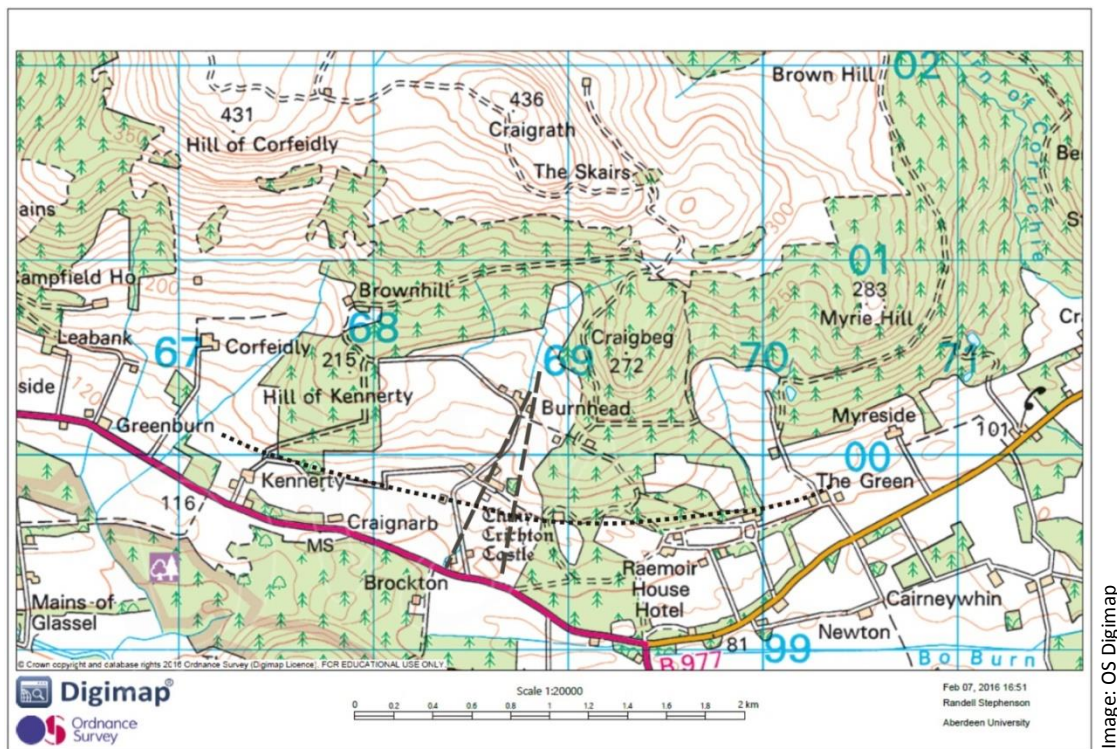
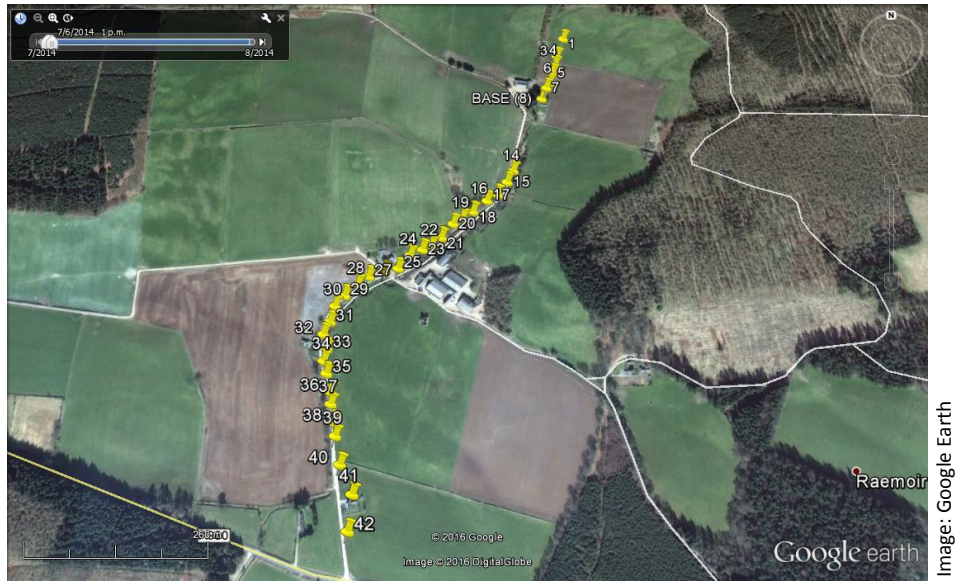

Figure 17 - Location of the observed gravity and magnetic profiles

Gravity observations were made every 15-20 m along the Burnhead farm road and in the field north of Burnhead cottage; the western “murky green” solid line represents a profile projection of the gravity data. Magnetic observations were made every ~10 m on a line roughly coincident with the eastern “murky green” solid line. The dotted line indicates the inferred contact between the Hill of Fare granite to the north and Dalradian (Argyll Group) metasedimentary rocks to the south (from BGS, 2002).





**Figure 18 – Locations of gravity stations along the track from the main road (A980) to Burnhead Farm**

Figure 18 shows the locations of gravity stations along the main road (A980) to Burnhead Farm. The Base Station (labelled 8 here) was near the farmhouse and several additional stations, not plotted here, were measured between it and Station 14.

The Earth’s gravity field is sensitive to height (altitude) as well as latitude and variability associated with these is not of geological interest so corrections are made to account for them. In particular the relative altitudes of stations must be known very accurately. In the present case, with geological variability in the order of 0.1 mGal, elevations should be known to within 30-50 cm. Differential GNSS equipment was used to determine horizontal as well as sufficient vertical co-ordinates at each measurement station with each observation point requiring some 20 minutes of data accumulation. Analyses during and after the fieldwork, however, revealed that the vertical co-ordinate was not likely recorded with the intended accuracy of  $\pm 1-10$  cm although the reason(s) for this are not clear. It is estimated that elevations are known only to  $\pm 1$  m at best and this has resulted in some degradation of the resolution of the calculated gravity anomalies.

Figure 19 shows the observed gravity anomalies corrected for latitude and elevation changes, along the projected profile shown in Figure 17. The absolute values of the gravity anomalies do not have significance (they are calculated relative to the base station value at Burnhead cottage) but the change in anomaly value along the line does. The observed anomalies have an absolute range of about 2.5 mGal (milligals). “Noise” levels related to height measurement inaccuracy are in the range 0.5 mGal.

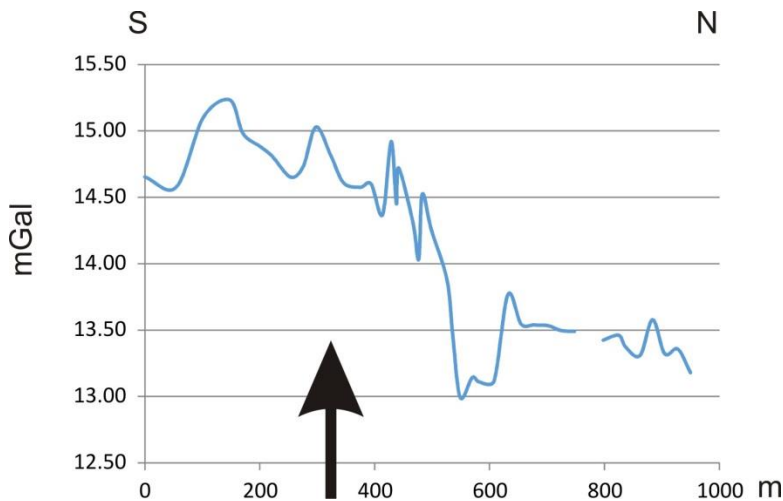

Figure 19 - Gravity anomalies along the (westerly) profile shown in Figure 17

The arrow in Figure 19 shows the approximate location of the inferred Hill of Fare granite-country rock contact from BGS (2002).

Magnetic observations were made on 9 October 2015 using a Geometrics G-857 magnetometer. Measurements of the magnetic field are sensitive to nearby metal and electrical currents so they must be made at least 10 m from fences and overhead wiring. For this reason measurements were taken in the middle of fields. Access was easy and non-problematic as crops had already been harvested. Some 90 stations were observed roughly along the line shown in Figure 17 with gaps between stations being greater where fences between fields were encountered. (An additional line of observations was made running roughly in an E-W direction in fields north of highway 977 east of “The Green” farm [cf. Fig. 17] but these are not discussed further here.)

Besides the profile magnetic measurements being made a second magnetometer is used as a “base station”, remaining stationary but recording continuously throughout the survey period so that diurnal variations in the Earth’s magnetic field (related, for example, to electrical activity in the atmosphere and/or solar activity) are known and can be removed from the station observations.

Figure 20 shows magnetic anomalies, corrected for the diurnal variations, along the profile located in Figure 17. The observed anomalies lie in the range -160-250 nT (nanotesla). A correction for latitudinal variation, which in the UK is about 2 nT/km increasing to the north-west, was not applied but the effect is clearly very small compared to the size of the observed anomalies.

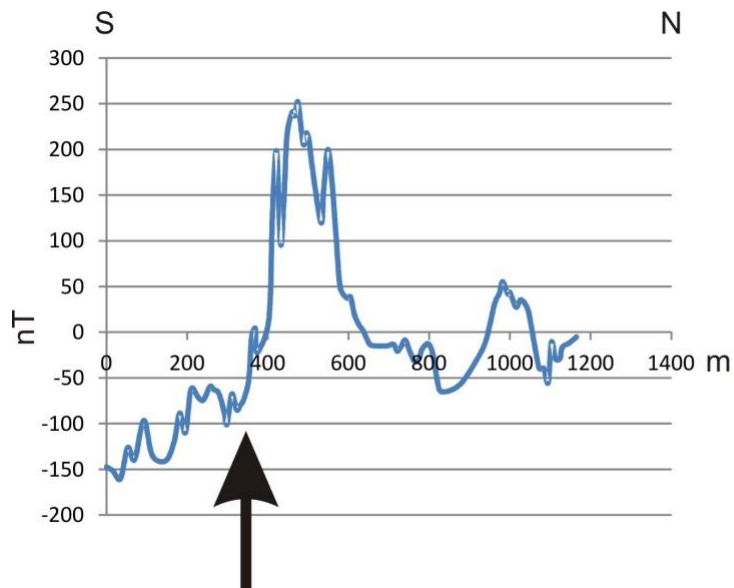

**Figure 20 - Magnetic anomalies along the (easterly) profile shown in Figure 17**

The arrow in Figure 20 shows the approximate location of the inferred Hill of Fare granite-country rock contact from BGS (2002).

### Discussion

The gravity field along the observed profile (Fig. 19) is dominated by a gradient derived from sources that are more regionally and more deeply distributed than the small scale of the ~1 km long survey itself. The polarity of the observed local gradient, with gravity decreasing to the north, appears to be consistent with what can be inferred from the regional field as seen in Figure 16 and what is indicated on the BGS (2002) geological map of the area. Given that the density of the Hill of Fare granite is thought to be less than the adjoining metasedimentary country rocks (McGregor and Wilson, 1967) it can be inferred that the (regional) source of the gradient is the large Hill of Fare pluton itself along with associated granitic bodies occupying the crust north of the survey area. There is a suggestion of an increase in (negative) gradient just to the north of the BGS (2002) inferred contact (in the distance range ~400-600 m), which would be expected since this contact lies near the ground surface and suggesting that the actual contact is some tens of metres further north than where it has been mapped. The negative perturbation in the distance range 500-600 m is the local feature that is greater than perturbations that are likely noise (altitude measurement) related. It may be related to a buried channel on the soil-bedrock surface, something that is suggested by the physiography of the area.

The magnetic field along the observed profile (Figure 20) clearly shows the signature anomaly of the edge of a buried magnetic body (such as an igneous intrusion) adjacent to relatively non-magnetic country rocks (e.g. Kearey *et al.* 2002). This is in the distance range~ 250-650 m with a positive peak of about 250 nT and probably a negative lobe to the south of some -50 nT. A theoretical example of the same effect – which is the magnetic anomaly of the magnetic body induced by the Earth’s own magnetic field superimposed upon the Earth’s own field, is shown in Figure 21. The observed data were complicated by superimposed regional or other intermediate and local effects as well as noise. The last may include “cultural noise” derived from buried pipes and cables, since the survey took place

near a built area with dwellings and other (farm) buildings, although typically these would have an identifiable effect. A second magnetic anomaly, centred at around 1000 m, is also evident. If the larger of the two anomalies is the signature of the geological contact of interest then it is near its location inferred by BGS (2002), though perhaps some tens of metres further north of the arrow in Figure 20, but the second, smaller, anomaly indicates that there may be structural complications and/or compositional heterogeneity within the Hill of Fare granite at the scale of the survey.

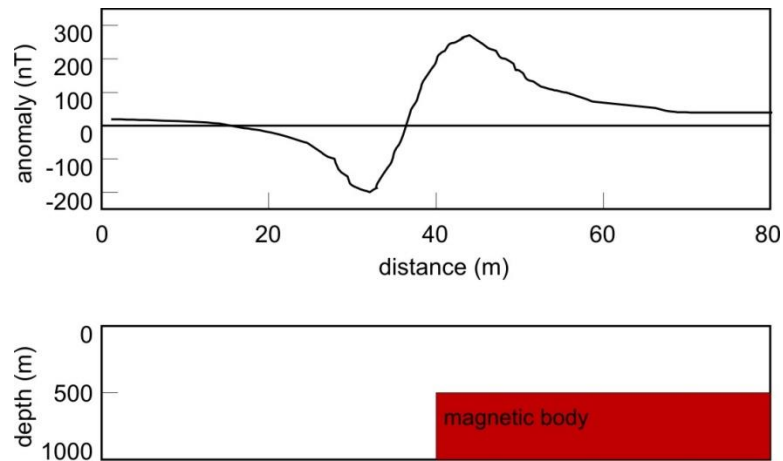

Figure 21 - Theoretical effect in the induced magnetic field of the contact of a magnetic body and a non-magnetic one

### Conclusions and prognosis

High resolution gravity and magnetic surveying is possible in the fields at the base of the Hill of Fare granite in the vicinity of its contact with Dalradian Supergroup country rocks. There are significant magnetic field anomalies that appear very likely related to the granite-country rock contact and they suggest that there is local compositional heterogeneity within the upper hundreds of metres (below the present ground surface) of the igneous pluton. In contrast, there are no specific small scale local effects in the gravity field associated with the granite-country rock contact although there is a suggestion of an increased negative (to the north) gradient in the gravity field that could be indicative of the country rock-pluton contact. One likely significant local anomaly is probably related to the underlying bedrock topography. Otherwise, the gravity field is dominated by the effects of larger, more regional structures such as the Hill of Fare body itself as a whole.

A high resolution magnetic survey on a 2-3 km<sup>2</sup> grid would provide sufficient data and data redundancy to allow three-dimensional modelling of the subsurface structure and composition on a local scale. These data could be augmented with new gravity and magnetic observations at lower resolution spacing in the surrounding area (say ~15-20 km<sup>2</sup>) to provide further context for the locally inferred structure and strengthen its robustness.

## 7. Assessment of Existing Baseline Data

### Potential fluid flow rates in the Hill of Fare granite

#### *Fractures in granite*

In granite, fluid flow is generally concentrated in fault and fracture networks due to the very low permeability of the rock mass. These faults and fractures are typically heterogeneously distributed due to the long and complicated tectonic history of many granites. Fractures can either be distributed evenly throughout the rock or they can be tightly clustered in fracture zones with larger expanses of relatively intact rock between; different granite bodies will display fracture distributions somewhere between these two extremes. Since the faults and fractures are controls on permeability their properties affect how easy it is to transmit fluid through the granite. These properties are frequency, fracture length, orientation, connectivity, mineral fill, and aperture. The combination of these influences creates significant challenges to predicting the permeability of granite at depth.

Figure 22 shows examples of fracture systems intercepted by drilling in geothermal boreholes. Observations from these examples are generally consistent, in that the fractures appear in small discrete zones surrounded by larger areas of more intact granite. In the case of the Habenero project these fracture zones could be matched up between boreholes so although each fracture system is discrete they are extensive and can operate over a wide area within the granite (Wyborn 2010). Underground excavations related to radioactive waste disposal have encountered more evenly distributed fracture distribution within granite although still with significant variation (Olkiewicz 1979) however this study was at much shallower depth, being only within 400m of the surface.

Figure 22 shows three examples of fracture systems encountered in geothermal boreholes;

- a, is from Cooper Basin in Australia (Wyborn 2010) and shows three boreholes encountering the same fracture systems at different locations. Each of these fracture systems are separated by many tens of metres of relatively intact granite.
- b, shows the cumulative number of fractures encountered at depth within the granite by one of the boreholes in the Soultz-sous-Forêt geothermal project in France (Dezayes et al. 2010). Here zones of higher fracture density are separated by longer stretches of granite of lower fracture density (i.e. more intact).
- c, is from the Rosemanowes geothermal project in Cornwall, UK (Richards et al. 1994). The RH12 and RH15 boreholes show the location of fracture zones which were encountered in addition to the proportion of fluid flow rate which is attributed to each fracture zone. The %flow values indicate that a high proportion of the fluid flow was located within a relatively small proportion of the fractures.

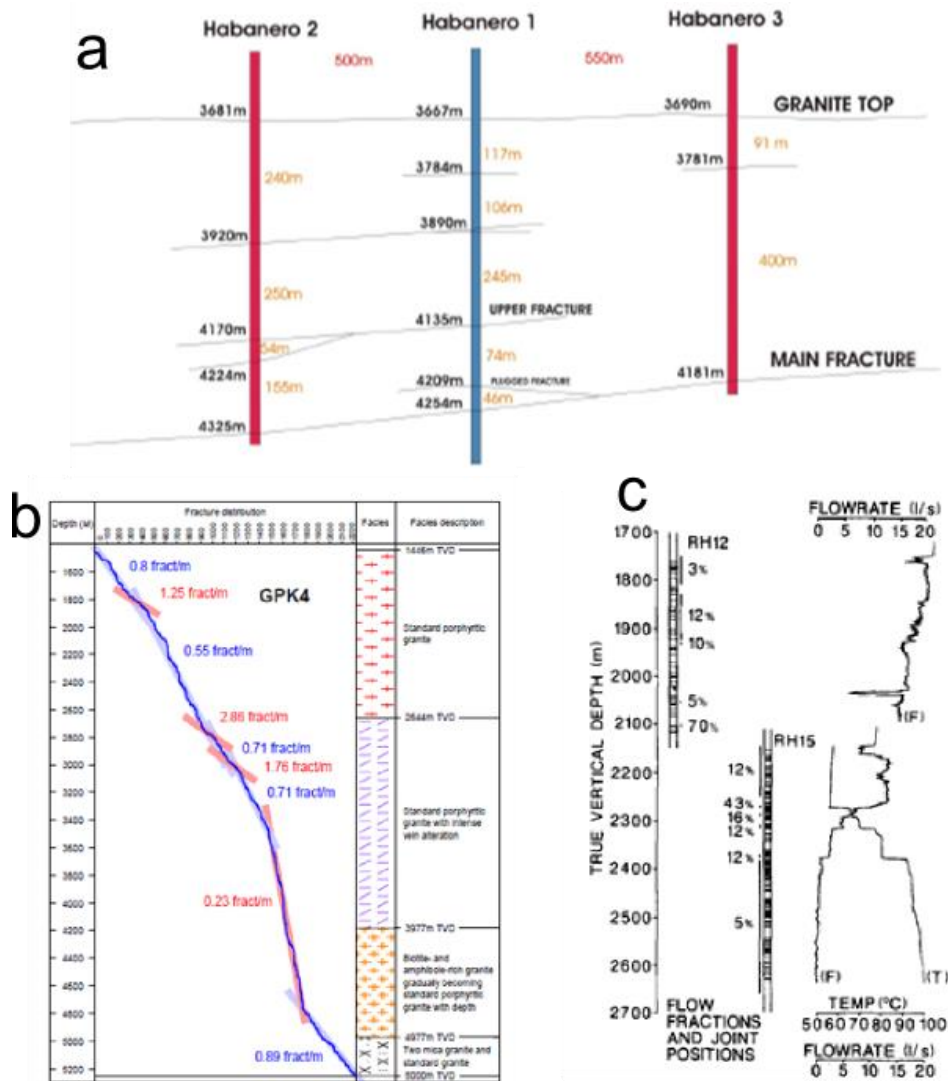

Figure 22 – Examples of Fracture Systems in granites

These localised fracture zones can create concentrated zones of fluid flow or permeability. This is demonstrated in Figure 22, c, where in borehole RH12 70% of the fluid flow comes from a single fracture zone; similarly, in RH15 43% of the fluid flow comes from a single fracture zone. Such discrete zones of fluid flow were also noted in the Swedish granite HDR experiment (Jupe et al. 1992) where two fracture zones appeared to be responsible for most of the fluid flow across hundreds of metres of the borehole. These observations are repeated by other studies not related to geothermal. Barton et al. 1995 found that hydraulically conductive fractures are a subset of the overall fracture population with many being closed to any fluid flow. The Swedish radioactive waste underground laboratory in fractured granite (Olkiewicz 1979) found a relatively more even distribution of fractures but the fluid flow was still attributed to a small subset of these fractures (Black 2007).

Information on fractures and faults in Scottish granite is sparse as few comprehensive studies have been conducted (an exception being Thomas et al. 2004). Old heat flow borehole records have been used to gain information about the fractures of the other high heat production granites in the East Grampians of Scotland. As previously mentioned, these

four boreholes were each 300m deep, and were drilled into the Ballater, Bennachie, Cairngorm, and Mount Battock granites. Three 10m cores from each borehole were taken at 90m, 190m, and 290m depth. From these cores the fractures were counted and their fracture densities (fractures per metre) calculated (Figure 23).

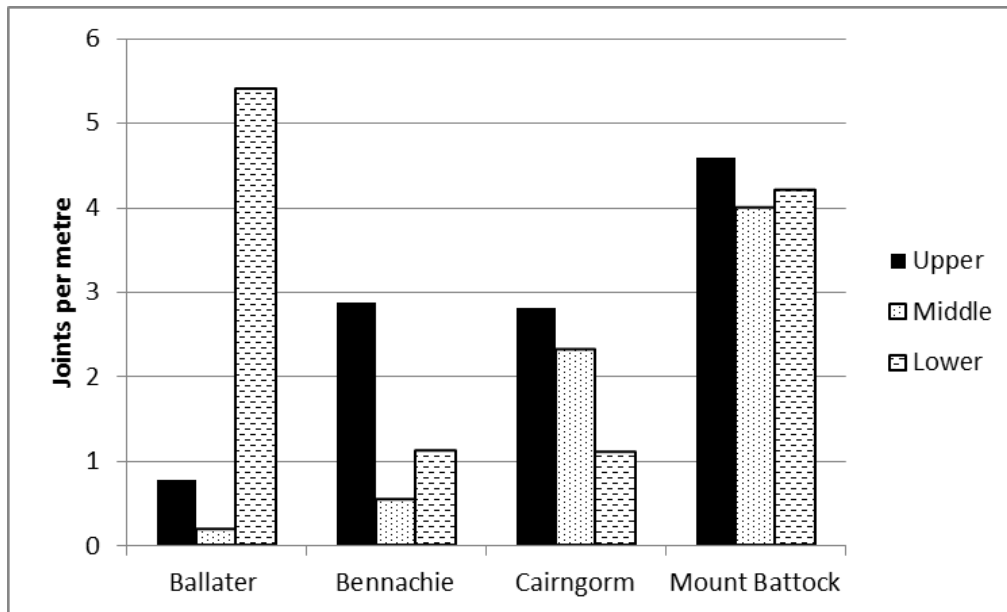

Image: Dr Alistair McCay

**Figure 23 – Fracture Density calculated from borehole cores of the high heat production East Grampian granites**

It must be borne in mind that the fracture densities shown in Figure 23 are for the first few hundred metres of depth. This upper part of granite is known as the ‘active’ zone and is likely to be more fractured than the deeper geothermal target zones. Each of the East Grampian granites has at least one zone of high fracture density (i.e. >2 fractures per metre). The fracture density in these zones is similar to that of the high density areas of Soultz-sous-Forêt (Figure 22b) which has had successful fluid circulation tests after further stimulation). That these zones exist within each of the East Grampian granites is positive as it indicates that such zones could also be found in the Hill of Fare Granite, possibly providing natural permeable zones. Nevertheless, it remains uncertain how these shallow fractures will correspond to those at the depths of interest.

***Fracture system on the Hill of Fare granite***

The first step in characterising the fracture patterns of the Hill of Fare granite would be a surface study of exposed fractures and faults. Unfortunately, initial field work showed that it would not be possible to collect robust data on the fractures without a much more detailed study requiring significantly more time and resources than the current study afforded. This could involve using a Lidar system at abandoned quarries in which the fracture orientations and distributions could be identified and analysed for otherwise inaccessible faces.

Despite the limited exposure, basic observations were still feasible at several abandoned flooded quarries. There appears to be a general trend for faults and fractures to be

contained within a single slip surface which has minimal surrounding damage. General sets of faults and fracture appear to strike either North to South or West to East.

The Hill of Fare granite was emplaced at the same time as the other high heat producing East Grampian granites (shown on Figure ES.2). The shared tectonic history between these granites suggests that the fractures of the Hill of Fare would likely be similar to those shown on Figure 22. Nevertheless, the emplacement of each granite creates unique conditions so while the other granites are analogous they cannot be assumed to be identical.

### ***Granite geothermal systems borehole flow rates: case studies***

The amount of energy that can be extracted from a geothermal system is dependent upon the flow rate from the production well. Therefore, in order to investigate the energy output from a possible geothermal system it is necessary to provide some constraints on possible flow rates through fracture systems in the Hill of Fare granite. There are insufficient site-specific data to constrain likely flow rates, as explained above. Consequently, we have used several case studies to inform what fluid flow rates have been achieved in previous geothermal demonstrations and operational schemes in fractured granite. The granites in these schemes will have already undergone an appraisal process like that presented here, and thus will already have been targeted for areas that are likely to be amenable to geothermal development. These case studies cannot be considered close analogues to the Hill of Fare, but are considered as examples should the Hill of Fare granite proceed to a more detailed pilot borehole appraisal in future.

In some cases granites can produce suitably high flow rates without stimulation (Manning *et al.* 2007). However, in most cases, hydraulic stimulation has been used to increase the permeability of the fractured granite. Following such stimulation, Evans *et al.* (2005) and Jupe *et al.* (1992) both reported increases in permeability of several orders of magnitude, while Chabora (2012) reported an increase in productivity of 10 times. Low-magnitude induced seismicity can be anticipated during such stimulation, though never at levels likely to cause any problems (Majer *et al.* 2007).

Each of the case studies listed below will have distinct fault/fracture distributions. However consistent trends across the case studies will inform upper bounds to fluid flow rates that could be expected from a successful geothermal scheme in the Hill of Fare granite.

- ***Cooper Basin, Australia***

The 1MWe Habanero Pilot plant is run by Geodynamics Ltd in the Cooper Basin in Australia. The plant targets natural occurring fractures, which are then hydraulically stimulated, in a granite body that is buried beneath several kilometres of sedimentary rock. The plant operated a trial at 4km depth where geothermal fluids were produced at 215<sup>0</sup>C at flow rates of 19 L/s. The planned flow rate for a production borehole in a full scale commercial plant is 70-100 L/s.

During the stimulation testing in the Cooper Basin granite, fluids were injected into the granite at flow rates of between 10-40 L/s (Baisch *et al.* 2006). The tests also



found that a single fracture within the granite could host flow rates of up to 30 L/s (Wyborn 2010).

- **Soultz-sous-Foret, France**

Soultz-sous-Foret (SSF) in France has been the location of the main European test site for Enhanced Geothermal Systems (EGS). A four month long trial circulated water between two boreholes (Gerard *et al* 2002) achieving a stable flow rate of 25 L/s.

During hydraulic stimulation tests at SSF fluids were successfully injected into the fractured granite at flow rates of 5 – 40 L/s.

- **Rosemanowes, U.K.**

This experimental EGS reservoir was created in the south-west of the UK in 1985. Stimulation of the fractures successfully linked an injection and production well with a separation of 133m. Testing continued for 300 days of circulation and achieved an average flow rate of 8.5 L/s (Richards *et al.* 1994), though ranging up to 20-35 L/s at various stages of testing. The planned commercial production flow rate for the scheme was 50 L/s, but the project never progressed beyond test phase.

- **Fjällbacka, Sweden**

Injection tests were carried out at an EGS test site in a jointed granite in Sweden (Jupe *et al.* 1992). Most of the fluid flow occurred at two highly-fractured hydraulically-conductive zones at 452m and 472m depth. A total of 400m<sup>3</sup> of fluid was injected at flow rates of between 20-30 L/s.

- **Weardale, U.K.**

An exploratory borehole targeted a fault known as the “Slitt Vein” in the Weardale granite (Manning *et al.* 2007). The granite is buried beneath several hundred metres of Carboniferous sedimentary rocks. A pumping test was carried out upon interception with the Slitt Vein to test the permeability of the fault and fracture system. Groundwater was pumped at 17 L/s for 24 hours with only a 1m drop in head suggesting a highly permeable active fracture system that could be sustained at far greater rates as part of a doublet well system (Younger and Manning 2010), with no need for stimulation. This underlines the value of deliberately targeting large faults that are inferred to be appropriately aligned with the present-day crustal stress field.

- **Fracture oil reservoirs**

Fractured basement rock (i.e. hard, crystalline rock lacking matrix permeability) is an uncommon but established target for oil and gas exploration. These hydrocarbon reservoirs are analogous to the fluid flow regime of a geothermal target in fractured granite. Experience in the hydrocarbon reservoirs suggest individual fault/fracture zones are capable of providing flow rates of between 1.5-10 L/s without any reported stimulation (Li *et al.* 2004, Tandom *et al.* 1999, Donofrio 1998). Individual boreholes within these reservoirs have experienced flow rates of up to 37 L/s when multiple fault/fracture zones are intercepted (Tandom *et al.* 1999).

## Constraining fluid flow rates for the Hill of Fare granites

The case studies above consistently show test circulation or injection fluid flow rates in the tens of litres per second. The test circulations ranged from a low average of 8.5 L/s at Rosemanowes, UK to 25 L/s at SSF, France, although Rosemanowes circulation did range up to 35l/s for a limited time. These test circulations indicated how much fluid it is feasible to circulate in a fractured granite if favourable conditions are found, such as those in Weardale, U.K where flow rates of up to 17 L/s were achieved with minimal head change in a pumping test (Younger and Manning 2010), without any stimulation of the fracture network. Additionally, the case studies of hydraulic stimulation of fractures show flow rates during injection that are similar to the above case studies for fluid circulation. The examples shown here indicate that a successful borehole-doublet in fracture granite would achieve flow rates of tens of litres per second.

Three flow rate scenarios were chosen with values informed from the case studies above (Table 6). These scenarios are not informed from any geological information from the Hill of Fare but are designed to be representative of a generic geothermal scheme in a fractured granite. As such they are not predictions of flow rates that could occur in the Hill of Fare granite, but will be used in subsequent upstream modelling to investigate how these hypothetical scenarios impact upon feasibility of the geothermal scheme.

Scenario	Flow rate (l/s)
Most Favourable	50
Intermediate	15
Least Favourable	5

Table 6 – Assumed flow rate scenarios for a borehole-doublet scheme in fractured granite

## 8. Vision Statement – A Deep Geothermal Heat System at Hill of Banchory

This chapter sets out a concept of what an ideal outcome of deep geothermal exploration at Hill of Banchory would mean.

### A trail-blazer for the deep geothermal sector in Scotland

The granites in the north east of Scotland undoubtedly contain large amounts of thermal energy suitable for exploitation as low-carbon, renewable heat. For that energy to be exploited commercially, the right combination of temperature and permeability must be present. Without actually drilling into the deep rock we cannot establish with certainty the quality of the geothermal resource. At present, we do not know if the Scottish granites offer exceptional geothermal potential, or something less attractive.

A deep geothermal borehole at Banchory would greatly improve our understanding of the deep geothermal potential of the Grampian granites. These extend over a large area of the country (see Figure 24) and could potentially represent a significant future energy resource for Scotland as a whole.

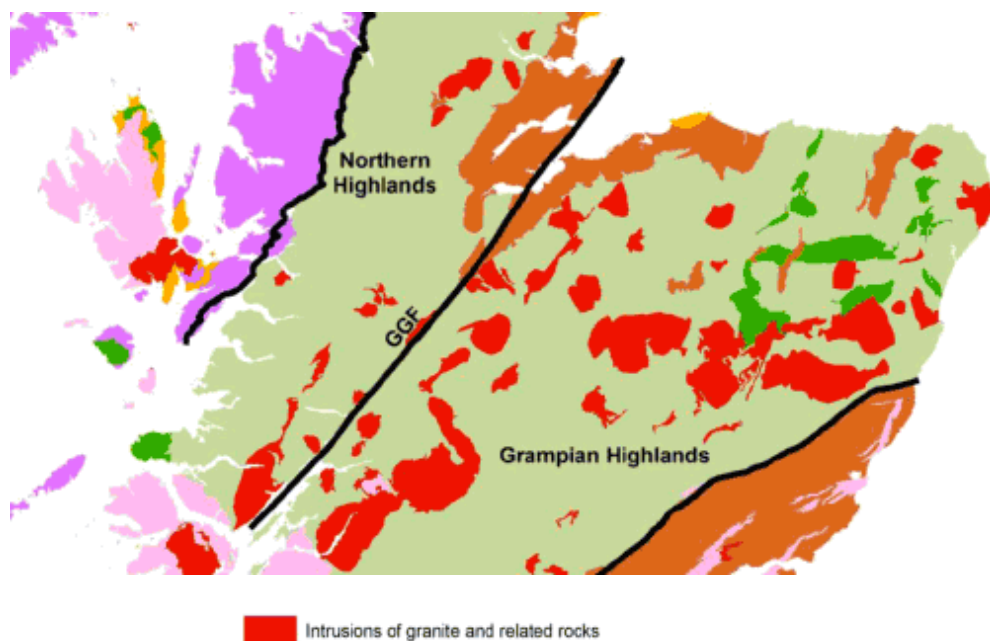

Contains British Geological Survey materials © NERC 2016

Figure 24 – Granite Plutons in Scotland

It is hard to put a figure on the overall energy potential of the Scottish granites, but the Weardale Granite underlying parts of the Pennines (which has no surface outcroppings) is estimated to have a heat potential of 9,000 MW – in other words, it produces as much heat in a year as Scotland's total annual heat demand. While only a fraction of that could be exploited commercially, the scale of this heat source strongly suggests that it is worth investigating the heat potential of the Scottish granites.

The sections below set out a vision of what would be possible if the geothermal potential at Hill of Fare proved to be good – which we have assumed to mean the well could produce 30 litres per second of water at a temperature of 75 °C. That equates to a heat source with a capacity of around 2.5 MW.

### **A sustainable source of ultra-low carbon heat energy**

Following the successful exploratory borehole, test pumping is conducted to establish how much water can be pumped sustainably from depth. In other words, it assesses how much hot water can be pumped out before the water level in the borehole drops below an economically viable maximum depth to the pump intake. Assuming a positive outcome, the other elements of the deep geothermal heat system will be put in place, chief among them the reinjection borehole. This will carry the geothermal water back to depth after useful heat has been extracted, creating a geothermal ‘doublet’ system. This is a typical arrangement for a deep geothermal heat system, and found widely in areas such as Iceland, Central Europe or Eastern Paris, where geothermal heat use is relatively common.

### **A minimal environmental footprint**

Pumps and a heat exchanger will be installed in a small containment building above the wellheads, which would be located somewhere in the sparsely populated farmland between the Hill of Fare and the northern outskirts of Banchory. The heat exchanger will be the interface between the geothermal water and fresh water circulating in the heat network pipelines.

The visual intrusion represented by the surface elements of the geothermal system will be extremely small. The building will be roughly on the scale of a two car garage, and can be designed to fit into the landscape. There will be no emissions of steam, or any other gases, as the geothermal boreholes will be a closed system. The piping carrying the water to and from Banchory will be buried where necessary to minimise visual intrusion.

Overall, the geothermal system should be so low key it could be overlooked entirely. Though this may seem unrealistic, the panorama of an urban area in Reykjavik (Figure 25) includes five geothermal wellheads with a total capacity of around 10 MW.



**Figure 25 – Geothermal wellfield in Reykjavik. The wells are in inconspicuous cabins about the size of bus shelters**

## **A long-lived, sustainable energy asset**

At the energy centre the hot water piped from the production borehole effectively becomes a 2.5 MW heat source that generates heat nearly continuously (in many existing systems the system loading is in excess of 90%, with down times for maintenance etc. scheduled in for periods of low demand). By making use of the existing heat stores already present in the HOBESCO system, demands of up to 5 MW peak can be met, ensuring that the heat from the well is used with high efficiency. Gas boilers, which are already in place, act as a back-up and for covering exceptionally high demand peaks.

Although the input temperature of 75°C is marginally too low to be used in much of the existing network without some boosting, the space heating systems across the later expansion stages of the Banchory heat network have been designed to accommodate the slightly lower temperatures coming from the geothermal well.

Operation and maintenance costs for the geothermal heat system are low. Thanks to the support from the Renewable Heat Incentive the price of heat to the network (and to the network's customers) is competitive and also highly stable; as the main input cost of a unit of heat is the financing of the boreholes and connecting piping, it is not exposed to the volatility of fossil fuel markets. After the capital costs have been paid off, the network will become a long-lived, fully sustainable low carbon energy asset able to supply very cheap heat.

A key advantage of a geothermal system is longevity. Although the pump and other small elements will need replacement every 10-15 years, the boreholes themselves should be very long lived and could potentially supply heat to Banchory for the rest of the century. The oldest geothermal heat system in the world in Boise, Idaho has been operating since the 1890s.

## **Ultra-low carbon heat, able to replace gas and heating oil**

The carbon intensity of deep geothermal energy is recognised as very low, especially for heat generation. 1 MWh of geothermal heat will give rise to fewer carbon emissions even than biomass or solar heating, and much less than 1 MWh of fossil fuel heating. Our calculations suggest that geothermal heating at Banchory, on a 'central' case of assumptions, will be 18 times less carbon intensive than natural gas heating (which is the least carbon intensive of the fossil fuel heating technologies). A 2.5 MW well running at a gross annual loading of 60%, and replacing gas heating, would deliver an annual saving of around 2250 tonnes of CO<sub>2</sub>.

## **A template for other geothermal systems across Scotland**

Once the practicality – and commercial validity – of a deep geothermal well utilising the heat from deep granite was established, the potential for rolling out similar projects across the NE of Scotland would be large. Each system would use only a small proportion of the available geothermal energy; and, as knowledge of the deep geology of the granite increased, risks - and thus financing costs - would reduce.

In time, deep geothermal systems could come to provide a core element of low carbon, sustainable and competitive heating for a significant number of Scots, contributing towards carbon emission reduction targets and improving energy security.

## 9. The potential market for a geothermal well; heat demand in Banchory

In the following three chapters we consider the financial aspects of the proposed project. In this Chapter, we consider the available heat demand in Banchory. In Chapter 10 we consider the economics of heat production from the well itself, and in Chapter 11 we consider the economic viability of a geothermal well in Banchory.

An essential element in any large scale heat generation project - renewable or otherwise – is availability of a suitable customer. Since there is no national heat grid (as is the case for electricity), establishing – with a high degree of confidence - local, secure heat loads must be a priority.

The Hill of Banchory (HOB) heat network is the most proximate potential customer for a geothermal well at Hill of Fare. In this chapter we assess the existing network demand (current and planned), and assess heat demand in the wider area of Banchory to determine other possible network opportunities that could either be developed in tandem with, or separately to, the HOB scheme, using data from the Scotland Heat Map.

### Hill of Banchory Heat Network

The current extent of the existing Hill of Banchory Network has been explained in Chapter 3. Future planned expansions for the Network are shown in Figure 26.

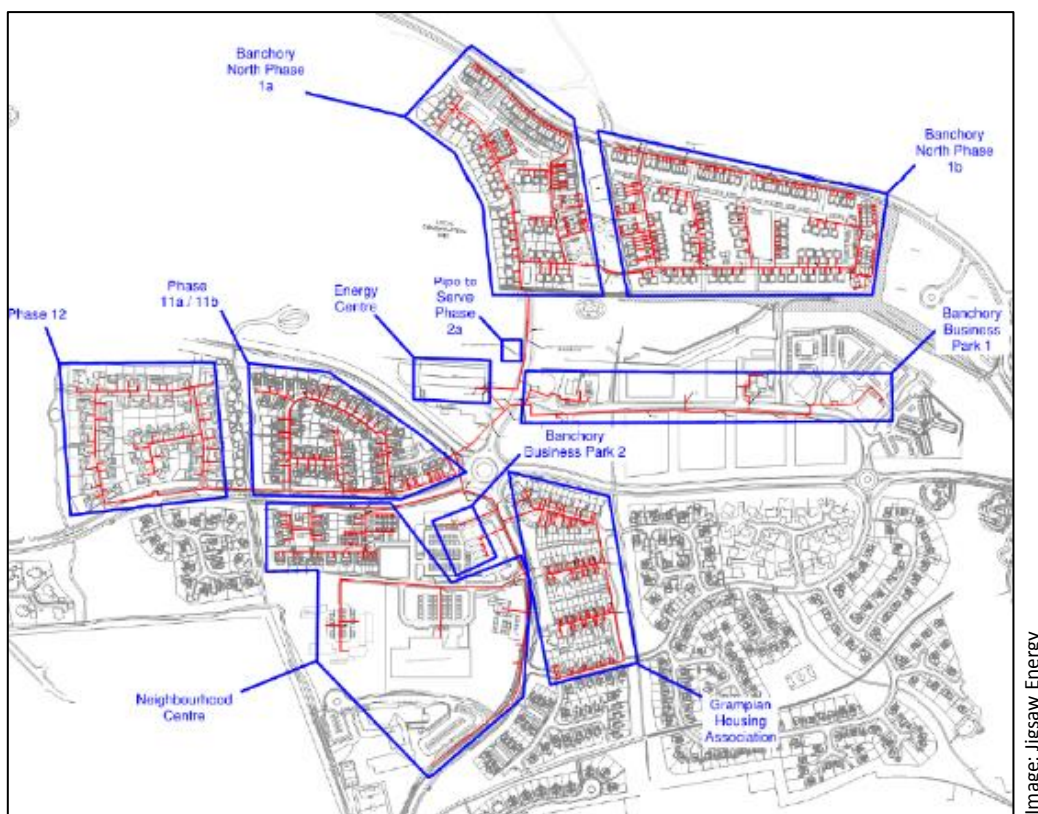

Figure 26 – Future Hill of Banchory Heat Network Expansions

Estimated heat demand for future developments in the Hill of Banchory Network are shown in Table 7.

Development Area	Diversified Peak (kW)	Peak (kW)	Annual Demand (MWh)	Connection Year
Phase 11/12 Residential	616	246	1,224	2012
BBP1	960	384	1,441	2012/15
BBP2	298	119	448	2015
Neighbourhood Centre	2,042	817	4,085	2016-18
North 1a	415	166	831	2016
North 1b	703	281	1,406	2017
North 2	888	355	1,780	2019
Grampian <sup>4</sup>	395	158	790	2020

**Table 7 – Future Expansions for the Hill of Banchory Heat Network**

It can be seen that over the next five years a substantial amount of new demand is planned to be connected to the HOB network, making full use of both the currently operational 900kW biomass boiler and the yet to be commissioned 700kW biomass boiler. The planned increase in demand is analysed in more detail below to determine whether the existing biomass capacity is likely to be sufficient to supply all of this demand, or whether another source of heat - for example geothermal - will be needed.

### **The Wider Heat Potential in Banchory**

The town of Banchory presents a large source of heat demand, approximately 85,000MWh in total.

A heat demand density analysis was performed to determine heat demand per square metre, measured in kWh/m<sup>2</sup>. This is a good early stage indicator of which areas will be best suited to district heating, as a high heat demand density suggests less pipe is required to supply the properties, resulting in a higher Linear Heat Density (LHD)<sup>5</sup> (Figure 27).

<sup>4</sup> Grampian Housing Association properties have not yet been agreed for connection but a heat supply agreement may be established in the future.

<sup>5</sup> LHD is a ratio of demand to pipe length (MWh/m) and can provide a good early stage indication of whether the network has enough demand to justify the initial capital costs of pipe installation.



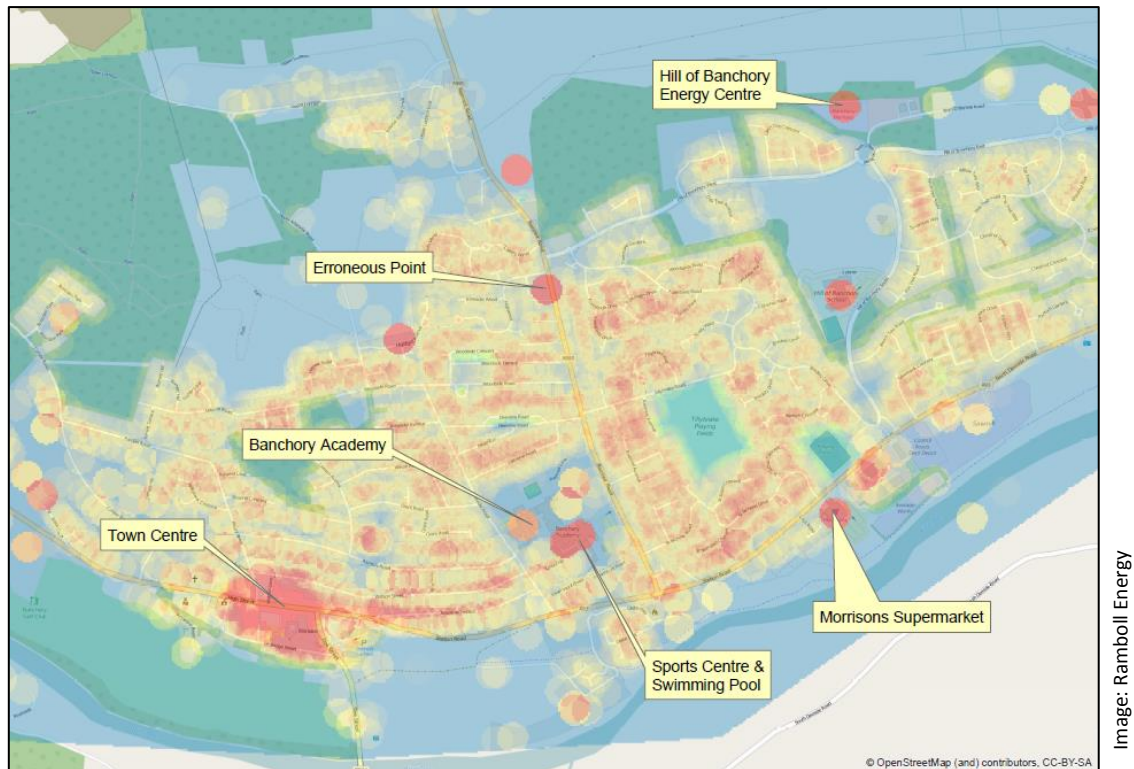

**Figure 27 – Heat Demand Density Analysis for Banchory**

In this analysis, each point is represented by a circle that is assigned a value according to the heat demand of that point. Where the circles of more than one point overlap, the demand is summed and the result of these points and summations are then colour coded from lowest (blue) to highest value (red). An erroneous point is not considered in any analysis.

As can be seen, there are some clear “hot spots” around Banchory, including some clusters of buildings in the town centre, and some large individual demand points such as the sports centre and the swimming pool. These areas were chosen to be the main focus points for proposed network designs and will be covered in more detail in the following chapter.

The majority of residential properties in Banchory are privately owned. There are Council-owned properties in the Raemoir housing estate which is sited close to Banchory Academy, a Primary School, a care home, and Banchory Sports Centre. These types of buildings are usually ideal candidates for connection to a DHN as they provide large, reliable sources of demand (often referred to as “anchor loads”) that provide baseload demand on the Network; particularly the swimming pool that requires almost constant heating. Connecting to Council-owned properties helps the Council reduce its carbon emissions and can assist in reducing fuel poverty amongst tenants. Councils may also be able to avoid building fabric upgrade costs by connecting to a Heat Network.

### **A preliminary appraisal of the network’s demand**

Once the shape of heat demand across Banchory had been identified and prioritised, preliminary network layouts were drawn using ArcGIS. These networks targeted all of the key points of heat demand that had been shown in the analysis of the heat map data. The

demand throughout Banchory is quite varied, which is a good thing for a district heating network as the different load types will help to flatten out the overall network demand profile throughout the day. This effectively raises the baseload threshold, meaning more of the heat could come from the geothermal source (which will produce heat at a constant rate).

These potential networks are shown in Figure 28. The existing Hill of Banchory Heat Network is shown in blue, while potential new Networks are shown in red. Connection to a new geothermal Wellhead would be via the dashed blue line.

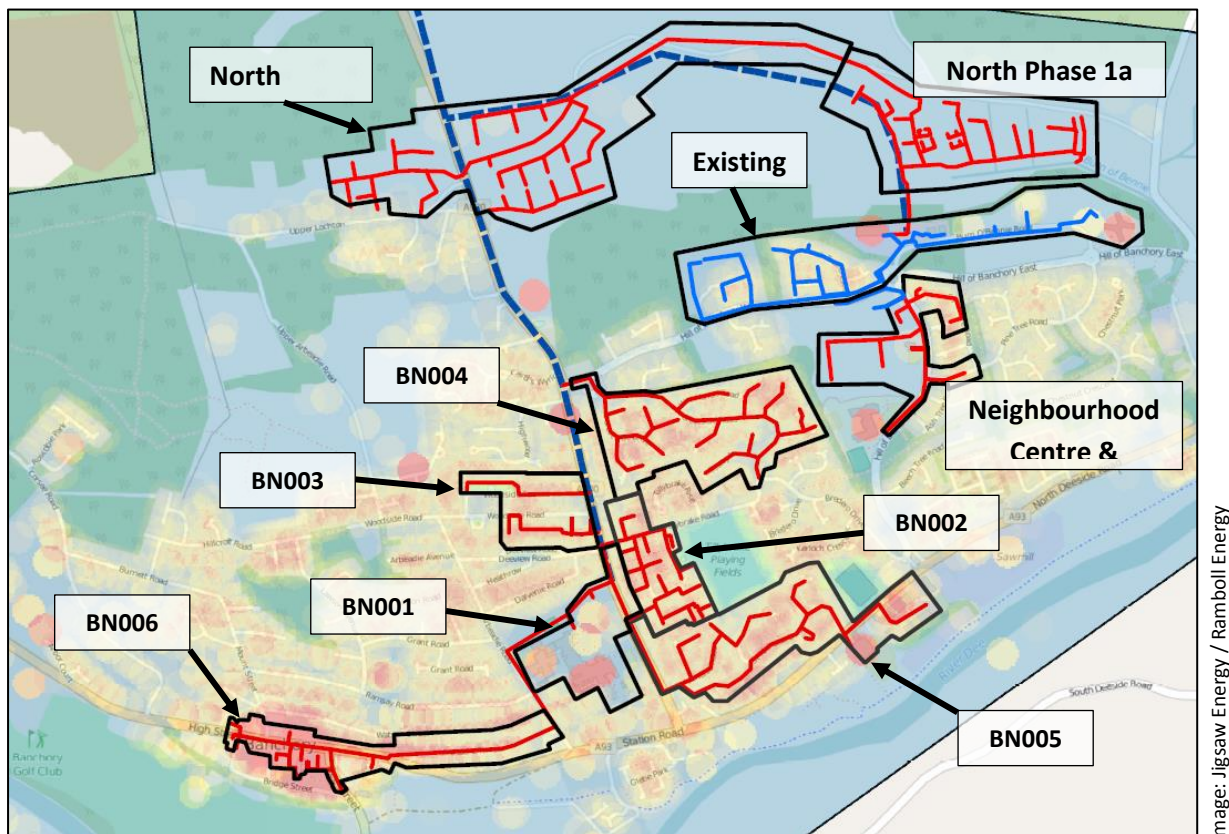

Figure 28 - Proposed Heat Networks in Banchory

- Network element BN001 – Banchory Academy

Banchory Academy and the surrounding area present a good source of demand as it consist of several large buildings concentrated into a small area. Adjacent to the school is a residential care home, sports centre and smaller Primary School. As these buildings are quite central in Banchory they would provide a good starting point from which the network could be expanded. Although it will require a large length of transmission pipe from the energy centre – probably located on the outskirts of Banchory – the length of pipe required to connect the points of high demand together would be relatively short, therefore ensuring a good linear heat density.

- BN002 – Raemoir Housing Estate

This first residential expansion would see the Council Properties in Raemoir Estate connect to the network. Although this area does not have a particularly high heat demand density, council housing properties are always a preferred customer of district heating networks as secure and affordable heating are an important part of providing affordable housing.

- BN003 – Woodside Residential

On inspection of the heat demand density analysis, it was seen that to the west of the main road into Banchory there was a patch of council-style housing that had a good demand. This was made more attractive as an option by the fact that rear access was possible to two rows of houses at once, providing a large demand for low length of pipe. This housing is most likely private so further investigation in the likelihood of connection should be undertaken before considering this option.

- BN004 – Forestside Residential

To the North of Banchory, lies another more modern residential area. Although this is a less closely packed area of housing, the properties tend to be larger and so the area has a good heat demand density. Once again these properties will all be privately owned so a large portion of individual connection arrangements would have to be agreed before this extension could be seriously considered.

- BN005 – Morrisons Supermarket

This extension could connect the network to the local Morrisons Supermarket as well as several potential customers in the industrial estate. These large commercial demands should help to increase the load diversity on the network and could provide some stable demand and therefore income. Although the supermarket is not particularly close to the previous network stages, there is a well suited path through another residential area with a good heat demand, meaning no pipe is wasted on transmission only.

- BN006 – Banchory Town Centre

Extension to Banchory town centre is the furthest away from the initial branch at the High School, but is also one of the largest sources of demand. The town centre has a large commercial demand, including retail, restaurants and hotels. Along with the densely packed residential properties, this could provide a concentrated demand for the network that would make up for the length of pipe required to reach it. The extension would also have the option of supplying some more residential properties along the way to help increase the overall linear heat density.

## **Network Options Appraisal**

Ramboll's District Heating Opportunity Assessment Tool (DHOAT), developed for the Scottish Government, was used to analyse the heat map data and preliminary network designs. This tool provides clear indications of what the peak and annual demands would be

at each stage of the network's development, as well as a preliminary set of KPI data including:

- Total heat demand
- Linear Heat Density
- Indicative CAPEX
- Indicative Network OPEX
- Indicative heat sales

The results are shown in Table 8.

Connection	BN001	BN002	BN003	BN004	BN005	BN006
Description	School area	Raemoir Estate	Woodside	Forestside	Morrisons	Banchory Town Centre
Network Length (m)	400	1,314	713	2,096	1,808	1,758
Heat Demand (MWh)	3,200	2,200	2,100	4,900	4,800	4,000
Peak Demand (MW)	1.58	1.11	1.07	2.44	2.72	2.30
Primary Supply Capacity (MW)	0.38	0.26	0.25	0.59	0.58	0.48
No. of Connections	23	164	113	192	237	182
Linear Heat Density (MWh/m)	8.0	1.7	3.0	2.3	2.6	2.3
Heat Sales Revenue	£148k	£131k	£127k	£291k	£282k	£240k
CAPEX	£1.5-£2.3m	£2.0-£3.3m	£1.5-£2.4m	£3.6-£5.9m	£3.6-£5.8m	£3.2-£5.2m
Weighted Average Heat Sales Price (£/MW)	£46	£60	£60	£59	£59	£60

Table 8 – District Heating Network Analysis

Table 8 shows the potential connections which are quite similar in terms of heat demand and linear heat density. Typically any network with a linear heat density greater than 3 could be viable, though it should not be assumed that values lower than this have no potential. BN001; the network supplying the Academy and surrounding buildings, yields the highest linear heat density of 8.0, showing how a large single consumer can improve the performance of a Network.

Given their large linear heat density, relative proximity to a new geothermal network connection, and the benefit of single tenure, BN001 and BN002, are most favourable for initial development.

## 10. The Economics of the Geothermal Well

We now move on to the economics of the geothermal well itself. The key question we seek to answer is: what is the likely unit cost of the heat produced by such a well? If this is too high it will be uncompetitive against alternative future heat sources for the Banchory heat network, such as natural gas or (especially) continuing biomass heat.

### Production costs: assumptions about the geothermal well

To model the financial viability of a geothermal heat generating station at Hill of Banchory we must first make some reasonable - and clearly defined - assumptions about the characteristics of the geothermal system itself. These will include:

- system lifetime;
- operation & maintenance costs;
- heat production capacity and (crucially)
- the likely capital cost of drilling the boreholes

### System lifetime and operation and maintenance costs

Deep geothermal heat systems are known for having exceptionally long lifespans – several decades is quite normal. From the point of view of financial modelling this could actually be problematic, as it raises difficult questions over how to value income far in the future. In practice, energy sector investors will not make decisions based on a time frame greater than 20-25 years. Furthermore, RHI income is only available to a project for 20 years from commissioning.

While we would expect the major physical elements of the system (especially the boreholes) to last for much longer, we have therefore based the financial modelling of the Banchory system on a **twenty year** lifetime.

For operations and maintenance costs, we have assumed a figure of **0.5p/kWh**, which is a normal (and quite conservative) assumption across the geothermal heat sector.

### The heat capacity of the geothermal well: flow rates and temperature

Chapters 4 to 7 set out the Consortium's analysis and conclusions about the likely geothermal potential of the Hill of Fare Pluton. These suggest that, on a reasonably conservative estimate, water temperatures of approximately 75°C could be obtained at a depth of 2.5 km. It is entirely reasonable that an efficient and effective heat network could operate using this input temperature; we might also assume a maximum achievable 'ΔT' (i.e. the difference between input and output temperatures for the heat network) of around 30°C,

with the network operating at between 70-80°C flow temperature and a 40-50°C return temperature.

We address the challenges of matching well output and network input temperatures below - the current HOB network operates on a flow/return of 85/60°C, with the return temperature sometimes being as high as 65°C.



Image: Cluff Geothermal / Hobesco

**Figure 29 – Biomass fuel at the Hill of Banchory Biomass Energy Centre**

### Flow rate

The available heat output from the system will be heavily dependent on the maximum sustainable flow rate (in litres per second) from the geothermal well. The geological members of the Consortium recommended that three representative flow scenarios ('favourable', 'modest', and 'unfavourable') should be used when modelling the geothermal potential as set out in Table 9.

Scenario	Flow rate (l/s)
Favourable	50
Modest	15
Unfavourable	5

**Table 9 – Estimated flow rates for the Hill of Fare granite at Banchory**

Table 10 below illustrates how flow rate and output temperature influences the heat capacity of the well. We vary the achievable  $\Delta T$  from 5-30°C and vary the flow rates across the 5 l/s to 50 l/s range suggested by our geological analysis. As will be seen, there are many combinations of flow rate and output temperature that imply a well heat capacity of more than about 1.5 megawatts, the level at which the project becomes worthwhile from a presentational point of view. If conditions turn out to be favourable, a capacity of 5 MW plus can be expected.

Heat available from resource (MW)										
Delta T (°C)	Flow Rate (l/s)									
	5	10	15	20	25	30	35	40	45	50
5	0.10	0.21	0.31	0.42	0.52	0.63	0.73	0.84	0.94	1.05
10	0.21	0.42	0.63	0.84	1.05	1.25	1.46	1.67	1.88	2.09
15	0.31	0.63	0.94	1.25	1.57	1.88	2.19	2.51	2.82	3.14
20	0.42	0.84	1.25	1.67	2.09	2.51	2.93	3.34	3.76	4.18
25	0.52	1.05	1.57	2.09	2.61	3.14	3.66	4.18	4.70	5.23
30	0.63	1.25	1.88	2.51	3.14	3.76	4.39	5.02	5.64	6.27

**Table 10 – Estimated heat available from geothermal resources for given flow rates and temperature drops**

It should be noted that the values in Table 10 are for the heat capacity of the well at the wellhead. There will be some heat loss as the heat is transported to the network and processed through the heat exchanger – though these should only be a few percent at most.

As the primary goal of this project was to look at the geothermal integration with the existing scheme, for the purposes of the financial modelling, the current network’s operating temperatures were used as a benchmark for the resource temperature requirements in the later stages of system design. In other words, we use as a benchmark a source temperature of 85°C, a minimum expected  $\Delta T$  of 20°C and thus a return temperature of 65°C. This will allow the geothermal well to interface directly with the HOB network.

### The capital costs of the boreholes

We have used £1.5 million as the approximate unit cost of the boreholes. Every borehole is different and the cost of each one is subject to uncertainty. However, we are aware of costs for similar geothermal boreholes in the recent past. We would also note that drill rig hire costs will depend, inevitably, on the level of demand in the UK onshore drilling market.

It must be noted that there will always be some uncertainty over the physical parameters of any proposed geothermal project. Ultimately, the output temperature and flow rate from the well will be known with 100% confidence only once a borehole has been drilled and the geothermal potential measured.

### Observations on the economics of deep geothermal heat systems

For almost all deep geothermal energy systems drilling costs will have a dominant impact on the cost per unit of heat generated. In this case, significant outlay will also be required for the pipeline connecting the Hill of Banchory Energy Centre to the likely site of the wellhead (which we assume will be not far from the B977 road).

Two other factors are key determinants of the final unit cost (here we have used pence per kilowatt-hour) of the geothermal heat produced. These are:



- volume of heat sold per year; and
- availability of subsidy income, in particular the Renewable Heat Incentive (RHI)

**Volume of heat sold.** This is important because the costs of building a deep geothermal system are only weakly proportional to the final heat capacity. Drilling the borehole(s) will inevitably involve a multi-million pound investment, and this must be made before any heat is produced. While there will be some continuing production costs (powering the pump, maintenance etc.) this up-front capital expenditure dominates the unit cost of heat, even in the medium to longer term.

Consider a 3 MW geothermal system that has cost, say, £3 million to build. The cost of financing an investment of this size will be high, certainly in the hundreds of thousands of pounds per year. For the sake of arithmetic simplicity, let us imagine that the full cost of operating the system and meeting the financing costs is £500,000 per year. If the system sells only 100 megawatt-hours (MWh) of heat per year, this would represent a very expensive way to produce heat: £5,000 per MWh. However, if the same system operates at a 40% load, it will sell 10,512 MWh per year at very little extra cost equating to a production cost of £48/MWh. (Given the long system lifetime we would expect unit heat cost to drop as the system reached financial maturity.)

In other words, the financial viability of a deep geothermal heat system is strongly dependent on good heat sales. The presence of the already existing Hill of Banchory heat network thus represents a great advantage to this project: subject to a suitable water temperature being achieved, it offers a ready-made large scale heat customer - and one with considerable scope for expansion.

**Renewable heat subsidies.** At present geothermal heat is eligible for support under the RHI at a rate of £50 per MWh produced. This is payable only on 'useful heat' i.e. heat that has been consumed by customers who meet defined energy efficiency standards i.e. it is not payable simply on heat produced. The RHI tariff is index linked and payable for 20 years from a system's commissioning date. DECC is currently considering a review of the structure of the RHI, though a commitment has been made to its future funding. The deep geothermal tariff is generally seen as unlikely to be adversely affected by the RHI review, though there can be no guarantee of this.

As a consequence of EU State Aid rules, projects in receipt of a public sector grant for the heat-production facilities (i.e. not including the cost of pipes, civils etc.) are not eligible for the RHI. However, OFGEM (who administer the RHI) have put in place a recognised and officially sanctioned process under which projects that pay back any such grants can regain RHI eligibility. In many cases the cumulative RHI payments will be more valuable than the grant, and this will normally be the case for deep geothermal projects. In modelling the financial viability of the Hill of Banchory project we have assumed that the grant will be paid back, using bank finance, in order to regain RHI eligibility.

## Results of the production costs modelling

The parameters set out above were input into an adaptation of Cluff Geothermal's financial model for deep geothermal heat systems. We also made some assumptions that are not directly dependent on the geothermal outcome:

- the RHI in the first year of operation is available at a rate of £52/MWh;
- the cost of the connecting pipeline between the wellhead and the heat network is £1,000,000;
- fixed annual costs for the geothermal well (site rental, salaries, are £20,000 per year);
- the relevant part of the grant can be repaid through a loan at 6% over 15 years; and
- heat prices rise with RPI, which we take to be 2.5%

We also need to decide how to compare the different variables. We have adopted an approach based on well capacity, desired rate of investment return, the associated price for heat sold, and – as the output - annual heat sales. For example, if the well has a capacity of 3 MW, and heat is sold at 1p/kWh, how much heat must be sold to meet an investor's required rate of return of - say - 10%. (These rates of IRR are not unreasonable given the high risk factor involved in this type of exploratory drilling)

To phrase this another way, given a particular combination of well capacity and required investment return, reviewing how the other variables scale tells us how much the geothermal operator needs to charge for heat for a given level of heat sales.

## Matching supply and demand

One complication for this part of the analysis is that the geothermal well will generally not be able to supply 100% of the heat demand from the network. Geothermal wells produce heat at a constant rate, while heat demand varies considerably both seasonably and diurnally. When demand is too high the well cannot simply be 'turned up' - instead, the backup heat generators (either gas or biomass) will need to cover the peaks. This problem is mitigated by having heat stores installed (essentially large water tanks; Kyriakis and Younger 2016). Such heat stores are already installed at Hill of Banchory.

This does not mean that heat customers cannot be supplied - it should always be possible to meet a given level of heat demand using the back-up heat sources. However, it does mean that some of the time the geothermal well is 'missing out' on supplying heat (and also receiving RHI income). Producing an exact figure for the percentage of 'missed sales' is not possible without knowing the exact future heat demand profiles. The model incorporates reasonable estimates for the 'missed heat' factor, for each geothermal well capacity being considered.

## Outputs of the financial model

We set out this relatively complex set of output data in Table 11 below, and also in graphical form in figure 31. The 'heat sales required' figure refers to the overall sales across the heat network; the actual heat sold by the geothermal well to the network will be slightly less.

<b>1.25 MW well</b>	
<b>To reach 10% IRR</b>	
Heat sold at	Heat sales required (MWh)
1p	13,600
2p	9,000
3p	6,650
<b>(1.25 MW well cannot reach 20% IRR)</b>	
<b>2.5 MW well</b>	
<b>To reach 10% IRR</b>	
Heat sold at	Heat sales required (MWh)
1p	9,800
2p	7,800
3p	6,650
<b>To reach 20% IRR</b>	
1p	cannot be reached
2p	7,800
3p	6,650
<b>4.25 MW well</b>	
<b>To reach 10% IRR</b>	
Heat sold at	Heat sales required (MWh)
1p	10,200
2p	8,100
3p	6,650
<b>To reach 20% IRR</b>	
1p	21,350
2p	17,500
3p	13,500

Table 11 – Heat sales required to reach 10% and 20% IRR for wells of differing capacities

## Summary of downstream financial model outputs

Given reasonable assumptions about the capacity of the well, a deep geothermal heat system at Banchory would be commercially viable if it could sell heat at 2p/kWh at a volume

approaching 10,000 MWh. This would make it competitive against natural gas heating, but not biomass at the lower end of the price range (as analysis in the following chapter shows).

### **Note - Output/input temperature: a key challenge for geothermal heat at Banchory**

Before moving on to consider the economics of the Banchory heat network itself, we consider one specific issue that has major implications for the system's overall viability. This is the output temperature of the geothermal well.

Many heat networks operate at a relatively high water input temperature – say 85-90 °C. This is the temperature of the water as it leaves the Energy Centre to begin its journey around the network. The existing Hill of Banchory network uses a flow temperature of 85°C. Given the typical thermal gradient in the UK, and the constraints imposed by drilling costs and likely levels of permeability, we would expect the output temperature of a geothermal well to be lower than this – perhaps in the range 60-85 °C.

If the geothermal well's output water temperature proved to be too low to be compatible with the existing heat network, there would be a requirement to boost it, either by fossil fuel or renewable means. That would mean extra cost, and it is possible this would increase unit heat costs to the point where they became uncompetitive. However, there is no reason that water at lower temperatures - 70 °C, say – cannot be used to provide space and water heating. However, doing so requires installing heat delivery equipment that is designed specifically to utilise lower temperatures (this can be underfloor heating or larger radiators). Retro-fitting existing residential heat customers to allow them to use lower temperature water in this way is generally expensive and unlikely to be economic – though the cost of conversion will be lower for larger scale heat customers.

**Our assumption is that powering the existing Hill of Banchory heat network using the water from the geothermal well (without boosting the temperature) is unlikely to be possible. However, it would be entirely possible to exploit the geothermal heat available if future extensions to the existing heat network are designed to be compatible with lower temperatures.**

There is real scope for this development route, building on cooperation with Aberdeenshire Council, which has several large properties and future projects in the areas most likely to see organic network expansion. These include a group of properties on Raemoir Road: the Banchory Academy and Sports Centre, Banchory Primary School and Nursery, Dalvenie Gardens Sheltered Housing and around 150 council-owned residential dwellings. The heat demand for these buildings was assessed in a report produced by Jigsaw Energy in 2013 as 5,300 MWh/yr, and peak load estimated at 3MW.<sup>6</sup>

A heat network large enough to make a 'mid-case', 2.5 MW geothermal well economically viable - for example, able to sell heat at 2p/kWh - would, under our analysis, require annual heat sales of 7,800 MWh. This group of properties would appear to form a highly attractive anchor heat load to form the core of such a network.

---

<sup>6</sup> Report to Aberdeenshire Council through AECOM (2013)

## 11. Integrating the Upstream and Downstream Economic Models

We now draw together the analysis set out in the two previous chapters to answer the key question: given the configuration of the current and future heat network at Hill of Banchory, and the financial constraints under which it operates, could it operate using the heat output of the proposed geothermal well, given our estimates of its likely capacity?

In terms of unit heat price, we can summarise our analysis in Figure 30 below, which shows how the unit price of heat sold from the geothermal well (blue line) and the required purchase price of heat for the heat network (green line) change as demand from the heat network increases.

In other words, the blue line indicates the unit price that heat can be sold from the geothermal well and still remain profitable for a given level of investment return. (As explained in the box on page 80 and 81, the high up-front capital cost and low operating costs of geothermal heat mean that this price falls steadily as more heat is sold.)

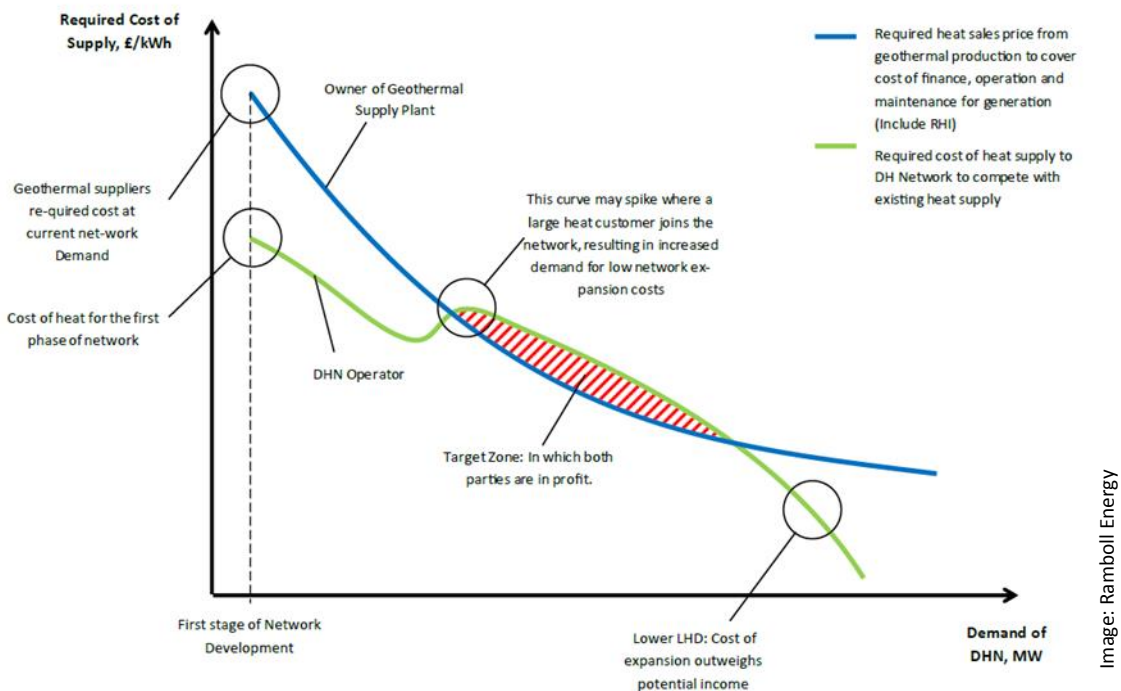

Figure 30 - Indicative Cost of Heat Model Outputs

The green line indicates the required cost of heat from the point of view of the heat network operator. As the heat network expands to service less densely grouped heat demands, more piping must be installed per unit of heat sold. This means that the network operator must produce heat at a lower unit cost if it is to remain profitable. Although the green line tends to fall from left to right as the size of the network increases, it does not do so monotonically – spikes can appear in the line as large heat customers join the network.

The red shaded area in this (indicative) graph shows the area in which the green line is above the blue line – which means there are levels of heat demand where both the

geothermal well and the heat network can make a profit: in other words, the system is economically viable. Does such a region exist for the Hill of Banchory heat network?

### Geothermal Heat Cost

As we have seen from Chapter 10, if the geothermal potential of the Hill of Fare site is able to support a geothermal well with a heat capacity of at least a few megawatts, and depending on a sufficient level of heat sales (perhaps 10,000 megawatt-hours per year or higher) it can achieve economic viability with sales of around 2p/kilowatt hour. With higher heat sales, the price could be lowered further and in ideal circumstances could approach 1p per kilowatt hour.

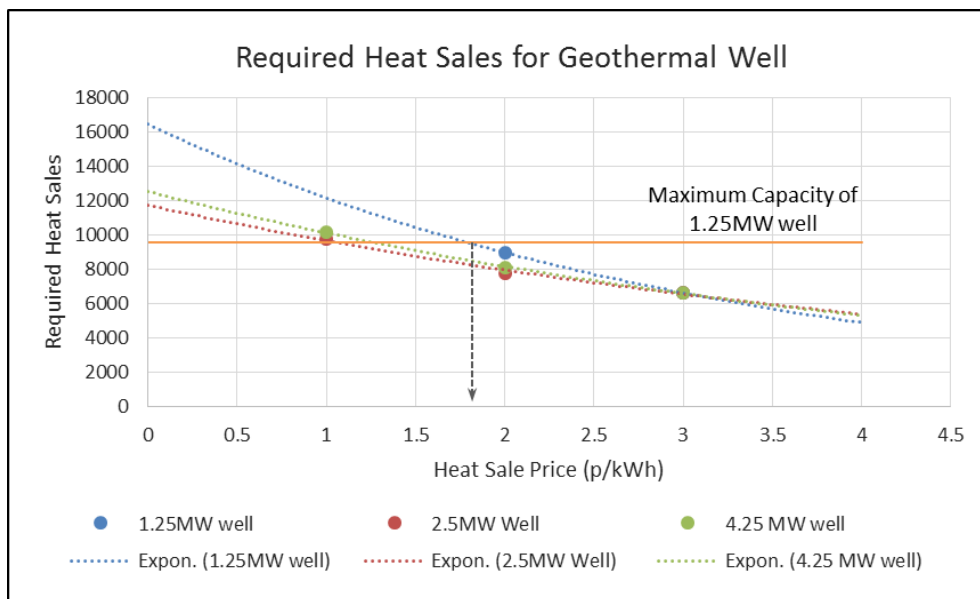

Figure 31 – Required heat sales for the geothermal well to be financially viable

The calculations around these results assumed that regardless of heating capacity the well's annual production would be limited to account for low summer demand and periods of maintenance down-time in which it could not run. This resulted in a yearly production limit for the wells calculated from: (well capacity x operating hours) which in turn defined a minimum heat sale price.

The existing HOB network uses biomass fuel. For the geothermal resource to be utilised in the existing HOB network, it would either have to replace the biomass boilers as the main heat supply, or there would have to be enough extra demand from the proposed expansions that it could be included as an extra primary heat source. For the former to be the case, the cost of heat from the geothermal supply would hence have to be lower than the current cost of heat from the biomass boilers. To make this comparison data were obtained from both the current network operator, HOBESCO and the team member responsible for the well costing; Cluff Geothermal.

## Current Fuel Cost Benchmark

The cost of delivered wood chips (at 40% moisture content) varies depending on the local market, and is typically around 3.1p/kWh. In comparison, due to their integrated woodfuel supply chain, HOBESCO's cost of biomass fuel is just 1.5p/kWh.

## RHI Tariff Considerations

A geothermal project is likely to take several years before it can supply heat. In Banchory further extensions to the HOB network would have been completed and the second biomass boiler would be operational. This would bring the energy centres total capacity to 1.6MW putting it over the “medium commercial scale” threshold of 1MW, and therefore lowering the available RHI income from the second boiler, as shown in Figure 32 below.

Medium commercial biomass	200 kWth and above & less than 1MWth	5.18
	Tier 1	
	200 kWth and above & less than 1MWth	
	Tier 2	2.24
Large commercial biomass	1MWth and above	2.03

Figure 32 – Commercial RHI Biomass Tariffs as of January 2016

A simple comparison of these figures shows that even for the reduced RHI tariff, currently 2.24 p/kWh, HOBESCO has a negative fuel cost of -0.53p/kWh. It should be noted that RHI is only payable on delivered heat, therefore network heat losses would diminish this margin. As well as this, there will be other costs involved in handling the biomass and running the energy centre, but many of these would remain irrespective of the source of heat. Despite these simplifications, the comparison shows that the geothermal supply would have to supply heat to the network at close to zero to be competitive, therefore relying solely on RHI payments for income; currently 5.08p/kWh.

Due to the difficulty of competing with the low cost of heat generation from biomass at Hill of Banchory, geothermal heat supply would have to be at a point where the biomass boilers had reached their maximum generation capacity, when the alternative heat supply would be natural gas. For this analysis the cost of natural gas heating was taken as 3.2p/kWh, based on an 80% efficiency and the most recent DECC announcements available at the time of writing. This suggests that by 2019 (given an assumption of rising fossil fuel prices), geothermal energy would be a potentially favourable option. The next step was therefore to assess the demand growth planned for the network and determine at what point this might be feasible.

## Network Growth Projections

To establish how much additional heat supply might be required due to the network expansions, it was first necessary to determine the annual capacity of the existing boilers. This was done by assuming that at their maximum operating conditions the boilers would be running for 5,000 equivalent full load running hours, which was then simply multiplied by the combined boiler capacity (1.6MW).

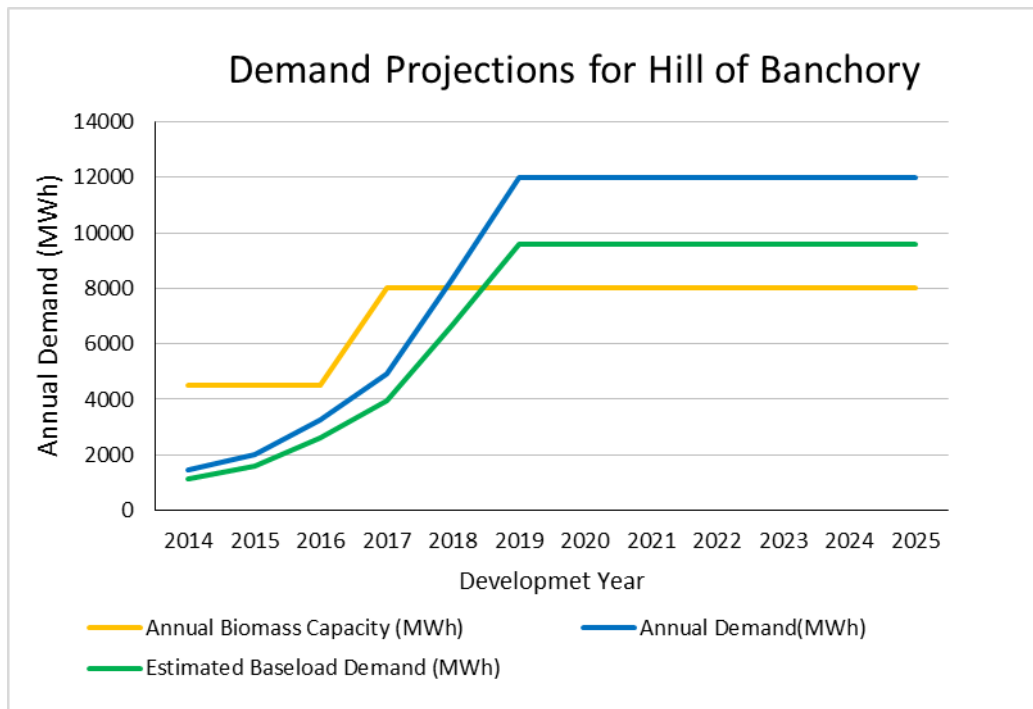

Figure 33 – Demand projections for the Hill of Banchory Heat Network

Figure 33 shows how the demand on the HOB network is planned to increase over the next 5-10 years along with the estimated generation capacity of the biomass boilers and the estimated proportion of demand that could be supplied by a baseload heat source, namely a geothermal supply. It can be seen that until 2018-19, the biomass boilers can supply the majority of demand, with a deficit of 2,000MWh per annum thereafter.

## Initial Conclusions

Considering the cheaper cost of heat that the biomass boilers provide, their maximal operation would be the first priority for HOBESCO, leaving 4,000 MWh per annum of demand that could in theory come from the geothermal supply. Referring back to the heat sales price estimates however, suggests that even when natural gas was the fuel source to compete against, therefore allowing the geothermal heat sale price to be at least 3p/kWh, around 6,500MWh of heat would have to be sold per year for the well to achieve its required IRR, i.e. more demand than is forecast under current plans, meaning the inclusion of at least some of the networks described in Chapter 9.



## The Network's required cost of heat

Our analysis suggests that for a geothermal heat scheme to have sufficient heat sales in Banchory to be commercially viable, extra demand above the existing forecast for the Hill of Banchory Network is required. A model was built to calculate how the cost of heat varies at different geographical scales of network and capacity of supply asset, using data from HOBESCO for the existing network and heat map data from the Scottish Government for the wider network opportunities (a list of the input variables is found in Appendix 2). The calculated cost of heat from the geothermal plant is shown in Figure 34.

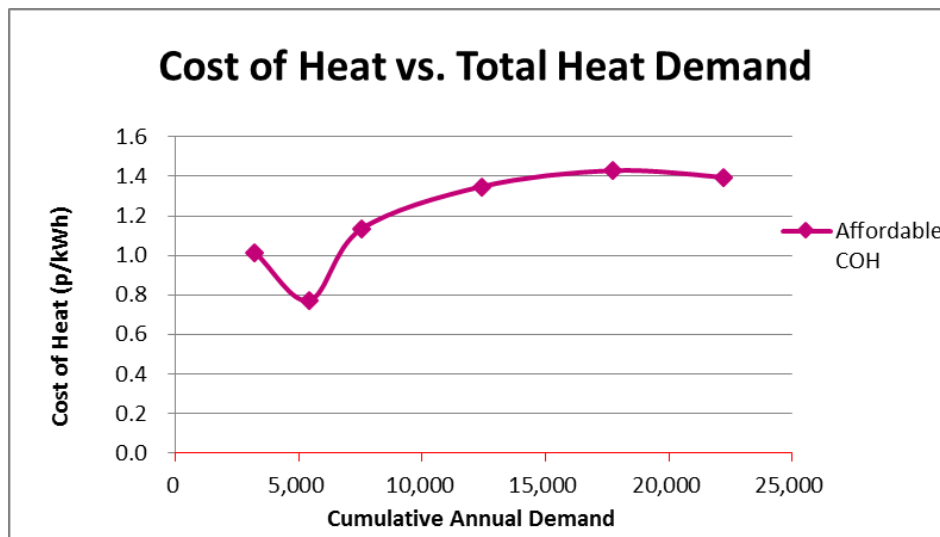

Figure 34 – Cost of heat model cumulative expansion results for proposed Banchory networks

Figure 34 shows that for most scales of network, the Banchory scheme could afford to pay at least 1p/kWh for its heat, a figure that is achievable from the geothermal operator's point of view provided at least 10 GWh of heat were sold per year.

## 12. Preliminary Heat Network Design Considerations

To be compatible with the customer heating system the geothermal heat supply must achieve specified parameters of flow and return (F/R) temperatures. With no upgrades to customer heating systems the network F/R temperatures would need to achieve 85/60°C. If customer upgrades to properties facilitated a low temperature network then 75/45°C may be achievable. A range of potential scenarios were evaluated at a high level for variations in flow rates and source temperatures to determine the most suitable type of heating system. This included a brief discussion on the pros and cons of each specific solution and the scenarios were then colour-coded based on their simplicity, cost of heat, and heat production capability as seen in Table 14.

Heat Available From Geothermal Resource				
Source Temp From Geothermal Well	<45°C	<75°C	>75°C	>85°C
Achievable ΔT	10	≈20	30	20
System Description	Not sufficient for low temperature network. Heat pump system used but lower delta T achievable due to lower source temperature.	Not sufficient for low temperature network. Heat exchangers and upgrade boilers used to meet final flow temp requirements.	Direct heating if network is altered to operate at low temperatures.	Suitable for direct heating in scheme with normal operating temperatures.
Cost Evaluation	More expensive heating system required and lower delta T and therefore COP increases cost of heat.	More expensive heating system, but no retrofitting is required. Extra cost of heat upgrade will increase as source temp decreases	Low equipment CAPEX but high modification costs as the system requires new buildings and all retrofit connections to be designed / refurbished for low temperature.	Cheap and Simple system with little to no building fabric work required. Can integrate with existing HOB scheme easily.
Flow = 5 l/s	Insufficient flow to operate a viable system. Only 314kW available.	Insufficient flow to operate a viable system. Only 627kW available.	Insufficient flow to operate a viable system. Only 418kW available.	Insufficient flow to operate a viable system. Only 630kW available.

<b>Flow = 15 l/s</b>	Insufficient flow to operate a viable system. Only 941kW available.	Could produce approximately 1.25MW. However heat will be more expensive.	Approximately 1.9MW available, therefore cost of heat limited to 0.5p minimum	Approximately 1.25MW available therefore would require a higher cost of heat.
<b>Flow = 30 l/s</b>	Could produce approximately 1.8MW. However heat will be more expensive.	Could produce approximately 2.5MW. However heat will be more expensive.	3.8MW available: Geothermal system has high enough capacity to cover costs if demand is available.	2.5MW available: Geothermal system has high enough capacity to cover costs if demand is available.
<b>Flow = 50 l/s</b>	Could produce approximately 3.7MW. However heat will be more expensive.	Could produce approximately 4.25MW. However heat will be more expensive.	Best case assumptions, 6.3MWth available, System has high enough capacity to cover costs if demand is available.	Best case assumptions, 4.25MW available, System has high enough capacity to cover costs if demand is available.

Table 12 - Summary and Evaluation of heating solutions for potential heat production scenarios at the Hill of Fare

Table 14 would inform a second phase of the project if a test borehole is commissioned and used to highlight the preferred system design based on more accurate temperature and flow data. A flow chart further illustrating this process can be seen in Figure 35 below.

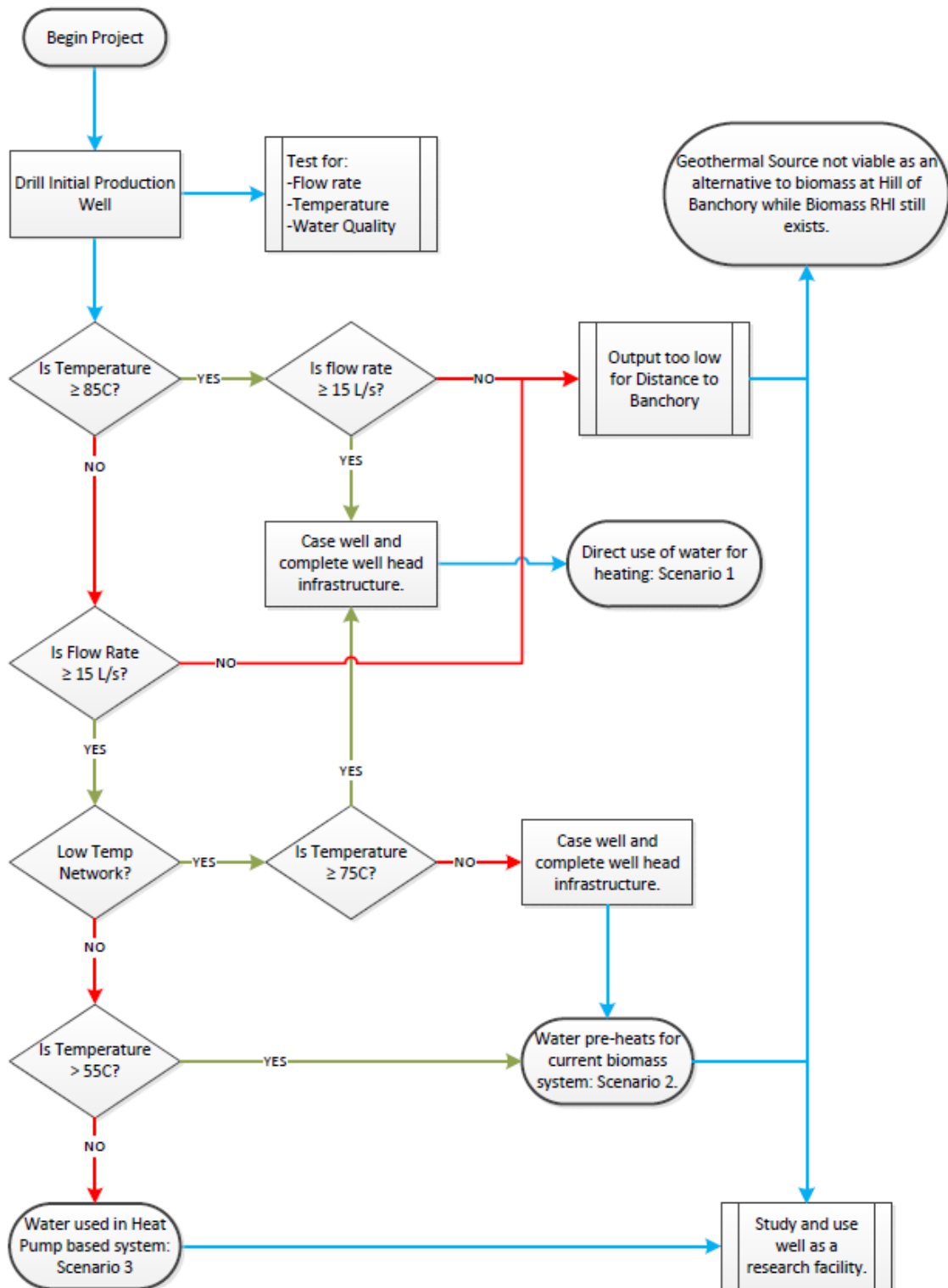

Figure 35 - Heating System Decision Flow Chart

## Summary of Technical Solutions

### Direct Heating

This is the simplest heating system design that could be employed at Banchory involving high capacity heat exchangers installed in the energy centre to extract heat from the geothermal fluid and transfer it into the network. However as there is no additional heat input, it would require the most favourable operating conditions, i.e. the source temperature would have to be above the network flow temperature. This becomes less likely for higher flow temperatures as the chances of obtaining that temperature decreases.

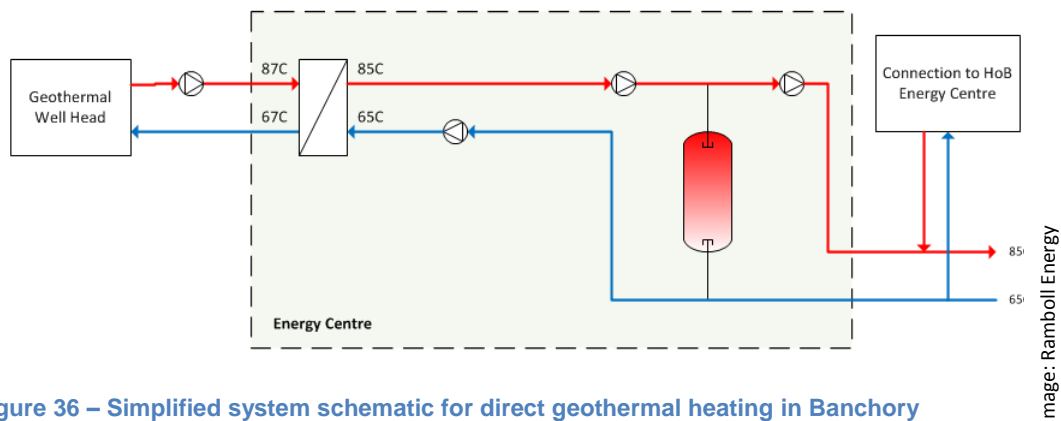

Figure 36 – Simplified system schematic for direct geothermal heating in Banchory

### Geothermal Pre-heating

If the temperature from the resource is below the required network flow temperature, good use could still be made of the geothermal energy by pre-heating the network flow and upgrading it using boilers to meet the desired network temperatures. The design of this type of system would depend on the return temperatures that can be achieved in the network since the source temperature would need to be higher than network return temperatures to have any pre-heating effect.

### High Source Temperature Heat Pump

It might be the case that the Hill of Fare granite can produce reasonably high flow rates, but at a much lower temperature than is required for direct heating. If the source temperature were to be close to or below the network return temperature, then it would be impossible to utilise any of the heat directly regardless of the flow (as the heat transfer is dependent on temperature difference).

One way to solve this problem and utilise the geothermal energy could be a heat pump.

To utilise more than just 5 degrees of delta T on the source side, an unbalanced flow heat exchanger could be utilised to warm an intermediate loop acting as the cold side input to the heat exchanger. This would extract 10°C from the geothermal source but only raise the heat

pumps input by 5°C by utilising a larger flow on that side. Figure 37 below shows an indicative set of conditions under which this may be used.

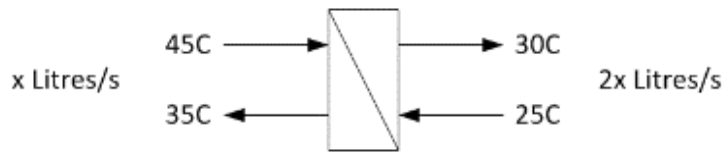

Figure 37 – Unbalanced flow heat exchanger to increase source-side temperature drop

## Conclusions

Although it was initially assumed that an existing network would be a positive asset to a future geothermal project, modelling has shown that existing operating parameters may constrain the ability of a new geothermal system to link-in and supply additional heat. Furthermore with the existing Hill of Banchory Network already receiving renewable energy generation, in the form of biomass, which benefits from a low cost base and government subsidy via the Renewable Heat Incentive, it makes it difficult for an alternative renewable resource to displace an existing renewable resource.

Whilst the existing circumstances for the Hill of Banchory Heat Network perhaps make this a somewhat exceptional case, were a similar geothermal system to be analysed as a standalone opportunity, or against fossil fuels as the alternative fuel, it could be a much more financially viable option. The prospect in Banchory of an expanded network beyond the scope of the existing scheme could present such an opportunity.

### 13. Risk Strategy

A risk and opportunity register has been compiled in this feasibility study. The register documents the current view of risks and opportunities and identifies potential actions that can be taken in the later stages of the project to reduce risks and access opportunities. In this project a risk is any issue that may lead to a loss in value; an opportunity can add value to the project. Risks and opportunities may be discrete events, such as loss of the RHI; or broader uncertainties, such as rock permeability being too low to give economic flow rates of hot water. Risks and opportunities have been recognised in all aspects of the project: subsurface; well design and tie in; District Heating Network; project financing; and stakeholder management. Risks have been ranked relatively from Low to High, where the ranking indicates both the potential impact on the project value if the risk materialises and the probability of the risk occurring. Risks are also ranked relatively according to the ability of the project to manage the risk, again from Low to High.

#### Risk Matrix

Figure 38 shows the current relative impact and manageability of risks included in the risk register which is in Appendix 2. The risks in the red top right hand corner are the most concerning as they have high impact and low manageability. The risks in the green bottom left hand corner are least significant, but should still be managed. Individual risks are colour coded by the area of the project.

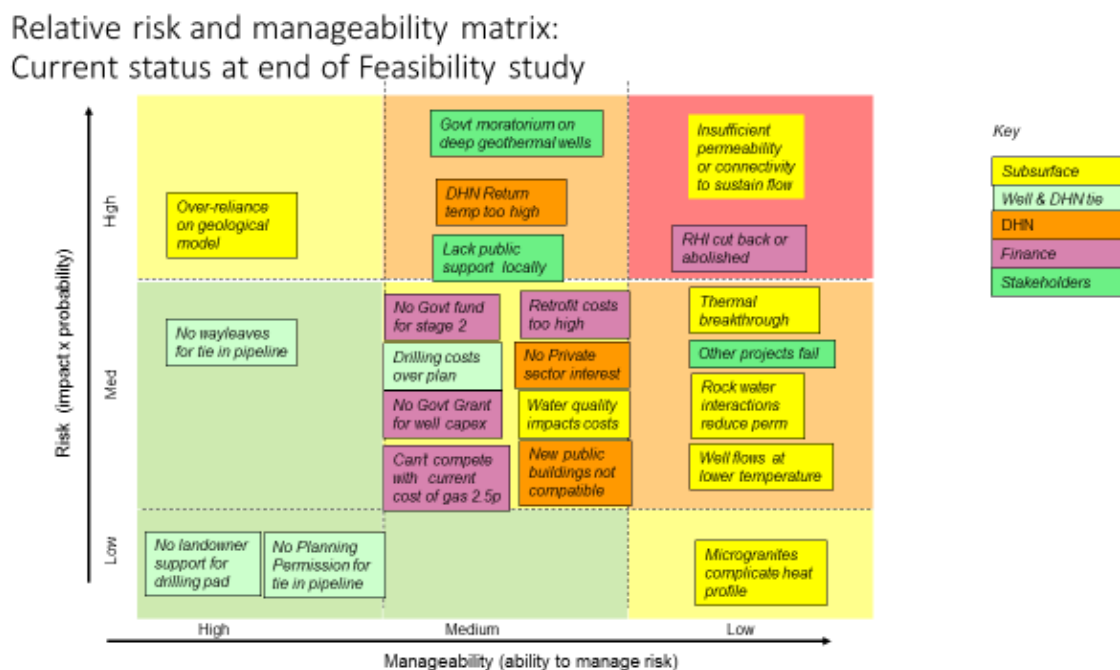

Figure 38 – Risk Matrix

## **Review of most significant risks**

### ***Insufficient permeability or connectivity to sustain flow***

The largest impact risk is that having drilled a deep well into the granite the well does not flow at adequate rates. At this point there will be large sunk costs, with limited opportunities to utilise the well. The following possibilities can be considered in the next stage to assess alternative uses for a poor well:

1. Evaluate and make case for well stimulation to improve flow rates
2. Evaluate completing a closed loop system
3. Evaluate completing as a low flow system
4. Abandon the well and Supply heat to expanded DHN from alternate sources, e.g. biomass, gas
5. Evaluate maintaining the well for research

There are further geological and geophysical studies that have been outlined in chapter 19 (Next Steps) which can reduce the risk of an unsuccessful well, but there will be residual risk prior to drilling that is irreducible given that this is the first geothermal well in the area.

### ***RHI cutback or abolition***

The project economics include an assumption that RHI remain available for deep geothermal wells as current. The value of RHI to the project is remarked on in Chapter 10. The recent changes in FIT and uncertainty about long term strategy towards renewable energy incentives at UK Government level raises the probability of loss or reduction of the RHI. The project can work with industry bodies to lobby for maintenance and certainty in policy.

### ***District heating return temperature too high***

There is a risk that the flowing temperature from the wellhead is too low to be easily utilised in the existing District Heating Network. Action can be taken to understand the range of useable temperatures, engineering solutions and costs, and depth of well prior to drilling, but some risk will remain until well productivity and temperature is assured.

### ***Lack of general public support locally***

The project plans an expansion of the District Heating Network into new public sector buildings and private sector homes. It will involve construction of pipelines for District Heating and to tie in the well. Each of these has an element of risk, which have been captured separately. Overall there is an additional risk that the public in the project area are



not supportive, raising objections, or misconceiving the risks through association with unpopular deep drilling activities in other parts of the UK. Early and frequent stakeholder and public engagement will mitigate all of these general and specific risks.

### ***Government moratorium on deep geothermal wells:***

There is presumably a risk that the existing Scottish Government moratorium on fracking could be extended to deep geothermal wells if there is likelihood that stimulation is required to deliver acceptable well productivity – albeit there is a vast difference in scale and risks between the two types of operation. Action would need to be taken to clearly articulate what the project will consider, and close cooperation with Government and local councils will be required to manage both the reality and the perceptions.

### ***Thermal breakthrough; rock water interactions reduce permeability; well flows at lower temperature***

These three risks are all essentially unpredictable uncertainties of the subsurface geology that will manifest themselves after drilling and after initial production. The project can attempt to cover acceptable uncertainty ranges in the economic evaluation, and can design in mitigations but cannot fully reduce these uncertainties.

### ***Opportunity to design and drill a test bore***

The project may evaluate drilling a shallow cored borehole extending several hundred metres below the weathering zone. This bore would aim to determine whether soluble minerals (e.g. calcite) form a significant component of the filling in the fracture network in the granite, and whether there is evidence for Recent or ongoing dissolution of soluble minerals (this would increase the likelihood that 'flow zones' in de-mineralised fractures occur at depth). A test bore may also measure the geothermal gradient, and possibly recover water samples.

All the risks and opportunities are described in the register in Appendix 3.

### **Risks after mitigation**

Figure 39 shows how the risks can be influenced if all mitigating actions are taken and are successful.

Relative risk and manageability matrix:  
 Future status if mitigating actions taken and successful

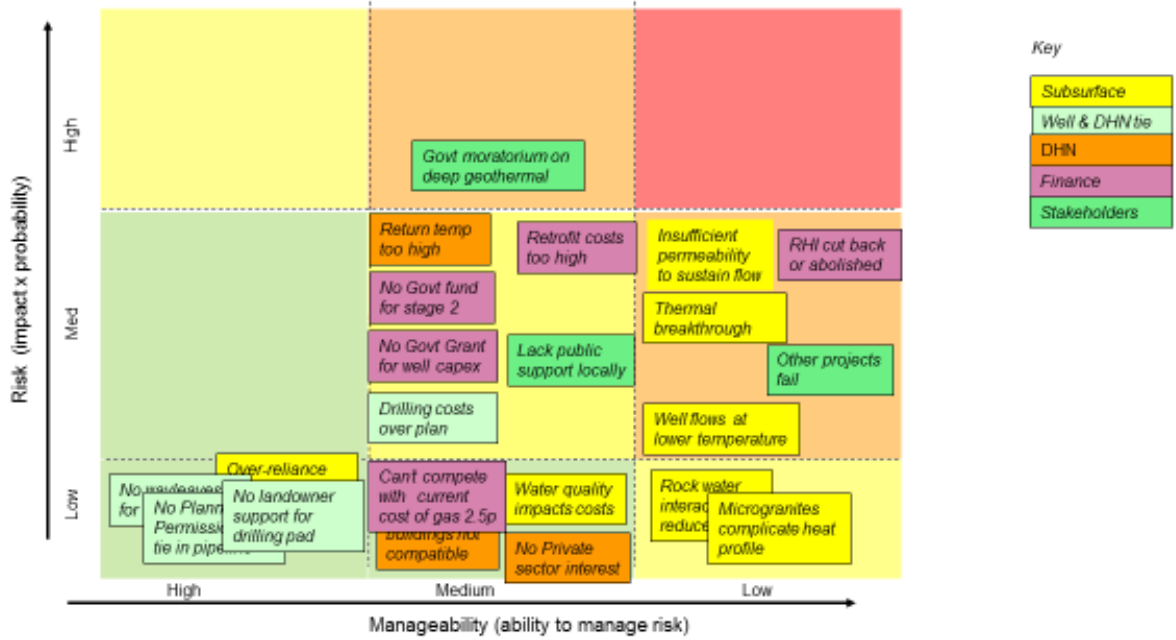

Figure 39 – Risk Matrix Post-Mitigation

## 14. Deep Geothermal Regulation

The regulation and control of activities which may be undertaken during the exploration and exploitation of geothermal heat is described in brief below, with reference to the Scottish Government's *Regulatory Guidance: Geothermal Heat in Scotland* (2016)<sup>7</sup> and to SEPA's *Supporting Guidance Groundwater Abstractions – Geothermal Energy* (WAT-SG-62)<sup>8</sup> (2014).

### Planning

Planning permission from the relevant Planning Authority is required for any new development – any building, engineering, mining or other operations in, on, over or under land – which includes works associated with borehole construction and wellhead development. As part of a planning application, an Environmental Impact Assessment may be required to be undertaken.

### Environment

The Scottish Environmental Protection Agency (SEPA) regulates activities that may cause pollution or that pose another risk to the environment. Abstractions (including borehole construction) from, and discharges to, the water environment are controlled activities as described by the Water Environment and Water Services (Scotland) Act 2003. The introduction of heat into the water environment is included in “pollution” as defined in the Act. SEPA regulates such activities through the Water Environment (Controlled Activities) (Scotland) Regulations 2011 ('CAR').

Operating a 'closed-loop' deep geothermal system, i.e. no abstractions from or discharges to the water environment, SEPA will generally not require authorisation under CAR as the impacts on groundwater are likely to be negligible. However, where a borehole is to be drilled to or below a depth of 200m a complex licence application is required. Details of information required to support an application are contained in SEPA's guidance document *Regulatory Method Licensing Groundwater Abstractions including Dewatering* (WAT-RM-11)<sup>9</sup> (2013).

### Operations / Health & Safety

Under the Water (Scotland) Act 1980 anyone proposing to sink a well or borehole for the purpose of searching for, or abstracting, water must notify the British Geological Survey

---

<sup>7</sup> [https://www.sepa.org.uk/media/151867/wat\\_rm\\_24.pdf](https://www.sepa.org.uk/media/151867/wat_rm_24.pdf)

<sup>8</sup> <https://www.sepa.org.uk/media/34709/wat-sg-62-groundwater-abstractions-geothermal-energy.pdf>

<sup>9</sup> <http://www.gov.scot/Topics/Business-Industry/Energy/Energy-sources/19185/GeothermalEnergy/RegulatoryGuidance>

(BGS) before drilling commences, and maintain a journal to be sent to BGS on completion or abandonment of the work.

The Borehole Sites and Operations Regulations 1995 are not applicable since the Hill of Banchory project does not involve mine water. The Offshore Installations and Wells (Design and Construction, etc.) Regulations 1996 places obligations on the operator concerning the safety of the well at all stages in its life. These Regulations inform the broader requirements of the Health and Safety at Work etc. Act 1974. Regulation 10 of the Management of Health and Safety at Work Regulations 1999 requires wellhead operators to provide employees with health surveillance. Provision and Use of Work Equipment Regulations 1998 requires that equipment is suitable for use, and for the purpose and conditions in which it is to be used. The equipment must also be maintained in a safe condition for use so that people's health and safety is not at risk.

## 15. Carbon Emissions Savings

### Overview

Deep geothermal energy is widely recognised as a very low carbon energy type, particularly when used to produce heat. The calculations set out below suggest that for a system with the same likely parameters as the proposed Banchory scheme each megawatt hour of thermal energy would produce around 4.4 KgCO<sub>2</sub>/MWh<sub>th</sub>. This compares to the commonly accepted figure of 184.45 KgCO<sub>2</sub>/ MWh<sub>th</sub> for natural gas, the most common type of heating in Scotland for both domestic and non-domestic consumers, and 246.57 KgCO<sub>2</sub>/MWh<sub>th</sub> for heating oil, the most common type of heating found off the gas grid.

Where geothermal heating replaces gas or oil heating, therefore, significant amounts of carbon emissions will be abated.

At Banchory, our calculations suggest that for a geothermal doublet system with a capacity of 2.5 MW<sub>th</sub> meeting 13,140 MWh of heat demand annually, where that demand had previously been met by natural gas, the annual amount of CO<sub>2</sub> abated would be approximately 2,370 tonnes. Over the thirty year lifetime of the geothermal system this equates to an abatement of 71,000 tonnes of CO<sub>2</sub>.

In the 'best possible case' under which a positive outcome to the Banchory project results in 250 similar geothermal heat projects across areas of Scotland with suitable granite plutons, we estimate the total carbon saving achievable as 900,000 tonnes of CO<sub>2</sub>. Such an outcome would be equivalent to meeting around 5% of Scotland's heat demand.

### The carbon footprint of deep geothermal energy

A commonly used unit of carbon intensity for heat is 'kilogrammes of carbon dioxide per megawatt-hour of heat produced' (KgCO<sub>2</sub>/MWh<sub>th</sub>). Various sources provide 'reference' figures for the carbon intensity of a wide range of heat-producing technologies. For example, in the UK Defra publishes the 'Greenhouse Gas Conversion Factor Repository'<sup>10</sup>, an official database that is often used when modelling carbon footprints or evaluating proposals for carbon emission reductions. We have used the Defra figures for this analysis.

Deep geothermal heat generation requires only minimal input of fossil fuels, and as a result it produces a very low level of greenhouse gases per megawatt hour of heat delivered. However, there are relatively few sources in the academic literature offering a detailed analysis of this question, or providing a reference figure for general use. The Defra tables do not quote figures for geothermal heat or power, for example. Internationally, figures are available for the carbon intensity of deep geothermal *power* production (for example, the standard figure given by the US Government<sup>11</sup> is 26.6 KgCO<sub>2</sub>/MWh<sub>e</sub>). This includes a large component of volcanogenic sources which are naturally rich in CO<sub>2</sub>, which is released to the atmosphere in flash steam operations. As geothermal heat production does not require

<sup>10</sup> <http://www.ukconversionfactorscarbonsmart.co.uk/>

<sup>11</sup> <http://www.theclimateregistry.org/wp-content/uploads/2015/04/2015-TCR-Default-EF-April-2015-FINAL.pdf>

venting, and as many of the mid-enthalpy sources used for heat do not contain natural CO<sub>2</sub> anyway, the equivalent carbon emissions figures for deep geothermal heat-only systems can be confidently be expected to be far lower than the figure for power production quoted above. Although accurate figures for deep geothermal heat production are as yet sparse, a review of various sources presented by Younger (2015) quotes a figure of 4 KgCO<sub>2</sub>/MWh<sub>th</sub>.

Instead of relying on such generalised estimates, we here calculate the likely carbon intensity of deep geothermal heat at Banchory from first principles, using reasonable assumptions and approximations. We do this on the basis of a 'full lifetime' calculation i.e. we consider the potential greenhouse gas emissions that arise in the course of a geothermal heat project, from the start of the borehole construction process through to the 'steady state' production of emissions while the system produces heat from the system over its lifetime. We do not include a calculation for the carbon emissions arising from decommissioning, which we judge to be *de minimis* in comparison with the construction of the boreholes and the operation of the system over decades.

### **Project Lifetime**

We make a conservative assumption that the lifetime of a deep geothermal system at Banchory will be thirty years. Systems can last much longer than this (one geothermal heat system in Boise, Idaho, has been in operation since the 1890s) but the lifetime will be dependent on local factors. This figure assumes there will be some refurbishment of the system, such as occasional pump replacement (over a thirty year lifetime the contribution of such refurbishments to overall carbon emissions should be negligible).

### **The potential for venting of gases from the geothermal fluids**

For completeness we should note in passing that greenhouse gases could be produced from the geothermal system in ways that are unrelated to energy consumption or heat production. Where systems in other countries are based on volcanic geothermal sources some greenhouse gases such as CO<sub>2</sub> may be vented. However this is highly unlikely in Aberdeenshire and we strongly expect that the geothermal water itself will not give rise to any greenhouse gases in this way. Indeed, the production and re-injection boreholes will be operated as a sealed system.

### **Carbon emitted prior to system operation**

Here we consider the carbon emissions that arise before the system is commissioned. This will include the 'embedded carbon' involved in the manufacture of the different elements of the system, and the carbon dioxide emitted during the drilling of the boreholes. There will be other sources of carbon - for example, that generated by activities associated with the planning phase of the project.

The 'embedded' carbon emissions associated with the system components can be divided into those from the manufacture of the surface elements of the system e.g. the pump, heat

exchanger etc. and those arising from the manufacture of the 'casings' – the stainless steel cylindrical lining that is generally used to stabilise the walls of boreholes as they are drilled. We judge the contributions from the surface elements are not large in scale (c.f. the carbon emissions involved in manufacturing a mid-size car are around 15 tonnes of CO<sub>2</sub>).

As noted in Section 6, the bulk of the steel casing will be 9 5/8" in diameter (dimensions in the drilling industry are still given in imperial units). Casing of this diameter should weigh no more than 100 kg/metre. We note from the World Steel Association's 'sustainability indicators' page<sup>12</sup> that producing a tonne of steel in 2014 can be assumed to release 1.9 tonnes of CO<sub>2</sub>. Therefore, 100 metres of casing can be taken to equate to 19 tonnes of CO<sub>2</sub>.

If both boreholes were fully cased – which would require 5,000 metres of casing – the associated embedded carbon associated with the casings could be significant, at around 950 tonnes. However, the Banchory project concept is based on drilling through granite, a very stable rock. We therefore expect that for the great majority of the boreholes' depth an 'open hole' approach will be used i.e. no casing will be needed as the walls of the borehole will be highly stable and reinforcement unnecessary. If, for example, each borehole was cased only to 500 metres depth, the associated CO<sub>2</sub> emissions would be around 190 tonnes.

We will take this as the central assumption, rounding up to **200 tonnes of CO<sub>2</sub>**.

### **GHG emissions arising from drilling the boreholes**

Moving on from the embedded carbon in the system components, another significant source of carbon emissions will be the fuel consumed by the drilling rig (these can vary considerably in size, but almost all run on diesel). For the Banchory project a relatively large drilling rig would be required, and based on consultations with drilling industry experts we expect such a rig to consume around 1,500 litres of diesel oil per day, or **62.5 litres per hour**.

There is inevitably some uncertainty in any estimation of the number of hours of operation required for the rig to drill to the required depth. Each drilling operation is different, and time taken will depend on the hardness of the rock strata and any difficulties encountered (lost drill bits, drilling into voids, the need to drill 'daughter' side boreholes etc.). However, we suggest that for a 2,000 to 2,500 metre borehole in granite a figure of 1,500 hours' drilling is a reasonable estimate.

This implies a total consumption of 1500 x 62.5 = 93,750 litres of diesel fuel per borehole. Given that we also need to drill a re-injection borehole we need to double this figure, to reach a final figure of **187,500 litres of diesel fuel consumed**.

Burning one litre of diesel fuel produces 2.4435 kg of CO<sub>2</sub><sup>13</sup>. Therefore the carbon emissions arising from the drilling of the two boreholes equate to 458,156 Kg CO<sub>2</sub>. Given the uncertainties involved we can reasonably approximate this to 460,000 Kg, or 460 tonnes of CO<sub>2</sub>.

---

<sup>12</sup> <https://www.worldsteel.org/statistics/Sustainability-indicators.html>

<sup>13</sup> <http://www.ukconversionfactorscarbonsmart.co.uk/>, 'fuels' worksheet.

## Carbon emissions arising from running the system

During the actual operation of the geothermal system the dominant energy input is the electrical power to the pump (we assume this will operate using grid electricity).

Note that the geothermal fluid (i.e. the hot water) need not be pumped from the full depth of the borehole; artesian pressure will raise the level of water in the borehole to the level of the local water table, a point much nearer to the surface (cf Younger and Manning 2010). This greatly reduces the work that must be done by the pump.

However, without knowing the *exact* level at which water will settle in the borehole - and therefore the height (or 'head') through which the pump will need to raise it - it is not possible to produce an exact figure for the amount of work done by the pump. By extension it is not possible to give an exact figure for the electricity consumed and, in turn, the CO<sub>2</sub> produced per megawatt-hour of heat that is ultimately generated. However, we can calculate the power required to raise water from an estimated minimum and maximum heads (which we take to be H<sub>min</sub> = 50 metres and H<sub>max</sub> = 100 metres) to give indicative figures for the power consumption.

The power used by the pump is given by the equation:

$$P = \rho g Q h / \eta$$

where P = the power in watts;  $\rho$  = fluid density (kg/m<sup>3</sup>); g = gravitational acceleration (in metres/s<sup>2</sup>); Q = pumping rate (in cubic metres per second); h = pumping head (in metres) and  $\eta$  = the efficiency of pump.

We use figures of 0.02 m<sup>3</sup>/s – 20 litres per second – as a reasonable proxy for the pumping rate, and 0.6 for the pump efficiency.

We calculate the pump power using the H<sub>min</sub> and H<sub>max</sub> figures for the pumping heads.

For H<sub>min</sub>:

$$\begin{aligned} P &= \rho g Q h / \eta \\ &= (1000 \times 9.81 \times 0.02 \times 50) / 0.6 \\ P &= 16,350 \text{ watts} = 16.35 \text{ kilowatts} \end{aligned}$$

For H<sub>max</sub>:

$$\begin{aligned} P &= (1000 \times 9.81 \times 0.02 \times 100) / 0.6 \\ &= 32,700 \text{ watts} = 32.7 \text{ kilowatts} \end{aligned}$$

Using this set of assumptions suggests that the pump power will range from 16.35 to 32.7 kilowatts. We now estimate the annual CO<sub>2</sub> footprint for pumps with these power ratings.

This part of the calculation is wholly dependent on the carbon intensity of the grid supply. At present this is 462.19 Kg of CO<sub>2</sub> per MWh supplied<sup>14</sup>. If the geothermal system operates

---

<sup>14</sup> <http://www.ukconversionfactorscarbonsmart.co.uk/>, 'UK electricity' worksheet



60% of the time (a reasonable assumption given the performance of similar systems in continental Europe) this equates to annual carbon emissions between 39.7 tonnes of CO<sub>2</sub> (min) and 79.4 tonnes of CO<sub>2</sub> (max).

Over the thirty year lifetime of the system, this suggests a range of carbon emissions of approximately 1,290 to 2,380 tonnes in total. However this would be a very conservative approach given that the carbon intensity of the UK grid is widely expected to fall over this period as coal fired power stations are phased out and lower carbon generation from renewables, nuclear and gas is phased in. In fact, the UK Government’s working assumption is that their ‘Electricity Market Reform’ policy changes will achieve a reduction of grid carbon intensity to only 100 grams of CO<sub>2</sub>/kWh of electricity generated by 2030 – less than a fifth of the current figure.

Decarbonising the grid this much is ambitious and may, of course, not be achieved for a variety of factors inside and outside the Government control. However it would be surprising if the carbon intensity of the grid did not reduce substantially over the 30 years from 2018 (which we take as the earliest commissioning date for a Banchory geothermal system).

As a compromise we will assume that the 100 grams of CO<sub>2</sub>/kWh target is reached, but at the end of the thirty year period of the system lifetime, and that grid intensity falls steadily over that time. In other words, we take the average carbon intensity of power taken from the grid over the plant’s operation as  $(462 - 100)/2 = 281$  grams CO<sub>2</sub>/kWh.

The minimum and maximum amounts of carbon generated by the pump’s operation over the system lifetime would thus become:

(minimum case)  $16.35 \times 8,760 \times 0.6 \times 0.281 \times 30 = 724.4$  tonnes of CO<sub>2</sub>.

(maximum case)  $32.7 \times 8,760 \times 0.6 \times 0.281 \times 30 = 1,448.9$  tonnes of CO<sub>2</sub>

We can reasonably round these figures to 725 and 1450 tonnes of CO<sub>2</sub> respectively.

### **Bringing the numbers together**

In summary, we have calculated the carbon emissions from the pre-commissioning phase of the project as:

Embedded carbon in the casings	200 tonnes CO <sub>2</sub>
Embedded carbon in the system surface elements	not significant
Emissions from diesel fuel required during drilling	460 tonnes CO <sub>2</sub> .
Total pre-operation:	660 tonnes CO <sub>2</sub>

During operation, the carbon emissions from the operation of the pump are projected to be:

Minimum assumed pump rating	725 tonnes CO <sub>2</sub> (over 30 yrs)
Maximum assumed pump rating	1,450 tonnes CO <sub>2</sub> (over 30 yrs)

Bringing the pre- and post-commissioning figures together, we find the following:

Minimum carbon emissions over project lifetime: 1,385 tonnes CO<sub>2</sub>  
Maximum carbon emissions over the project lifetime: 2,110 tonnes CO<sub>2</sub>.

To summarise, the main source of carbon emissions over the 30-year lifetime of the geothermal system is that associated with the electricity driving the pump. Having said this, the amount of carbon produced by drilling the borehole, and that embedded in the system's components, is not insignificant. The relative sizes of these contributions will depend on the exact depth from which the geothermal fluids will need to be pumped, and the depth to which the boreholes are cased.

### **Heat production over the project lifetime**

We now need to calculate the amount of heat produced by the geothermal system over its operational lifetime, being careful to ensure this is consistent with our other assumptions.

We assume that the well produces 2.5 MW of heat, a plausible mid-range figure for a geothermal borehole doublet. We also assume that the annual system loading is 60%. Over thirty years the heat generated by the system will therefore be

$$2.5 \times 8,760 \times 0.6 \times 30 = 394,200 \text{ megawatt-hours (} = 394,200,000 \text{ kilowatt-hours)}.$$

This is the equivalent of meeting 13,140 MWh of heat demand per year.

### **Heat from a geothermal system at Banchory would be very low carbon in nature**

Having calculated approximate bounds for the lifetime carbon emissions from the system, and a figure for the amount of heat produced over the same period, we can divide one by the other to find the average carbon intensity of the heat produced.

Lower bound on carbon intensity:

$$1,385 \text{ tonnes of CO}_2 / 394,200 \text{ megawatt-hours} = 3.5 \text{ KgCO}_2/\text{MWh}$$

Upper bound on carbon intensity:

$$2,110 \text{ tonnes of CO}_2 / 394,200 \text{ megawatt-hours} = 5.4 \text{ KgCO}_2/\text{MWh}$$

Taking the average of these upper and lower figures, we estimate that a deep geothermal heat system in Banchory would supply heat with a carbon intensity of 4.4 KgCO<sub>2</sub>/MWh<sub>th</sub>.

### **Carbon savings versus other heat production technologies**

The calculation above has given us a plausible range for the carbon intensity of geothermal heat production of 3.5 to 5.4 KgCO<sub>2</sub>/MWh. This compares to 184.5 kg of CO<sub>2</sub> per MWh of heat from natural gas central heating, 246.6 kg of CO<sub>2</sub> per MWh for heating from fuel oil, and 462 kg of CO<sub>2</sub> per MWh of electrical heat.

In other words, deep geothermal heat is exceptionally low carbon compared to other fossil fuel heating types, and in particular natural gas heat - the 'reference' heat type in the UK.

### **Potential carbon emission savings in Banchory**

As we noted above, we expect the geothermal system to produce 13,140 MWh of heat per year, with an average carbon intensity of 4.4 KgCO<sub>2</sub>/MWh<sub>th</sub>.

The amount of carbon abated by building the geothermal system will depend on the origin of the heat that it displaces. As discussed in the introductory chapter, the current heat network at Banchory used biomass fuel. This is widely recognised as having a low carbon intensity, with the exact figure dependent on the fuel variety (wood chip, wood pellets, for example) and on the distance the fuel had been transported. There is therefore no simple reference figure for biomass heat from wood chips. The (now rather dated) report 'Carbon factor for wood fuels for the Supplier Obligation - Final' gives a figure for combustion of 'UK forest residues' as 11-17 KgCO<sub>2</sub>/MWh<sup>15</sup>. The carbon intensity of heat from the Banchory heat network can be expected to be at or towards the lower end of this range, because the fuel used is forestry waste and thinnings from local sources, minimising transportation distances.

As will be noted, the figure we have arrived at for the carbon intensity of deep geothermal heat is still about half that of wood chip heat at the lower end of this range. This suggests that even against the current very low carbon arrangement a geothermal well would reduce carbon emissions.

Compared with the carbon intensities of common heating types, both deep geothermal and locally sourced biomass are very low carbon heating technologies. The carbon intensity of natural gas heating – which is used to meet the great majority of domestic and non-domestic heat demand – is given as 184.5 KgCO<sub>2</sub>/MWh in Defra's reference tables. In other words, a carbon intensity 39 times higher than our calculated figure for deep geothermal. (The figure given in the Defra tables for heating oil, another common heating type in rural Scotland, is 246.6 KgCO<sub>2</sub>/MWh, which is 52 times higher.)

In other words, where deep geothermal replaces natural gas heating there is scope for very large reduction in carbon emissions. Given that the vast majority of heat consumers in the Banchory area are likely to use natural gas heating (or electrical heating, which is even more carbon intensive), this is an entirely plausible scenario.

If we assume that the geothermal system produces 13,140 MWh of heat per year and this displaces the same amount of natural gas heating, the amount of carbon emissions saved annually will be:

$$(184.5 - 4.4) \times 13,140 \text{ Kg} = 2,366,514 \text{ Kg} \approx 2,367 \text{ tonnes of CO}_2 \text{ per year.}$$

Over thirty years operation the geothermal system would thus save around 71,000 tonnes of CO<sub>2</sub>.

---

<sup>15</sup> [https://www.gov.uk/government/uploads/system/uploads/attachment\\_data/file/48193/3153-final-report-carbon-factor.pdf](https://www.gov.uk/government/uploads/system/uploads/attachment_data/file/48193/3153-final-report-carbon-factor.pdf), fig. 3.1.

## Potential carbon savings across the rest of Scotland

This section considers how much carbon could be saved if it proved plausible to roll-out deep geothermal heat schemes *exploiting radiothermal granites* across the areas in Scotland where they are found. (We do not consider other types of deep geothermal schemes, such as those based on sedimentary aquifers, which may present opportunities elsewhere, such as the Central Belt.)

Such an exercise will inevitably carry uncertainties, but it is possible to draw some broad conclusions. Note that here we are considering the *technical* potential for what could be achieved in the long term i.e. we are not considering the *commercial* potential - what would be economically viable *now*.

In making this estimate we must make one subjective judgement call. This concerns how far we believe heat can be transported before the cost of pipework becomes prohibitively expensive, or thermal losses make the system unviable. Heat can, in fact, be transported over large distances without a problematic drop in temperature; a famous example is the Copenhagen heat main which allows heat to travel tens of kilometres from the city's periphery to reach high heat loads in the centre.

So it is not unreasonable to imagine some larger diameter heat mains carrying geothermal water from the edges of the granite plutons into urban areas – most obviously, Aberdeen.

### How much heat could be produced?

We assume that a typical deep geothermal doublet such as that proposed for Banchory will have a capacity of a few megawatts – let's take 3 MW as an average figure (note that if many such projects were rolled out significant expertise would presumably be acquired in maximising well outputs). We also assume that these are able to run at a loading of 90% (not unusual for systems of this kind, which are relatively common in other countries).

Wells must be far enough apart to prevent thermal 'short circuiting', where the re-injected colder fluids from one well find their way through horizontal pathways into the production borehole of a neighbouring system, reducing their effectiveness. Such considerations are important in places such as Reykjavik and Paris, where production and re-injection systems are relatively close together. In the latter location systems have been sited 2 km or less apart with no impact on sustainability.

Assuming that systems can be installed round the edges of all the granite plutons in the Cairngorms, and system separation was 2 km, we could expect to install 250 systems without creating an unsustainable impact on the geothermal potential. This equates to a geothermal capacity of  $250 \times 3 = 750 \text{ MW}_{\text{th}}$  the annual heat output would be

$$750 \times 8,760 \times 0.9 = 5,913 \text{ gigawatt-hours}$$

Given the uncertainties we can take this as approximately 6 terawatt-hours (TWh).

## How much heat demand would be within range?

Scotland is a voracious consumer of heat. According to 'Energy in Scotland 2014'<sup>16</sup> total non-electrical heat demand in that year was 86.8 TWh, or 55% of Scotland's total energy consumption.

The Scottish heat map, an online resource, allows us to measure the amount of heat demand in any defined area. Bearing in mind our assumption (above) that meeting heat demands within tens of kilometres – but not more – is reasonable, we will assume that Aberdeen and the surrounding areas can be supplied by granite-based heat systems. This leads us to identify the area shown in pink in Figure 40 below as able to be supplied with deep geothermal heat. It covers the local authority areas of Angus, Perth and Kinross, Highland, Moray, Aberdeenshire and Aberdeen City.

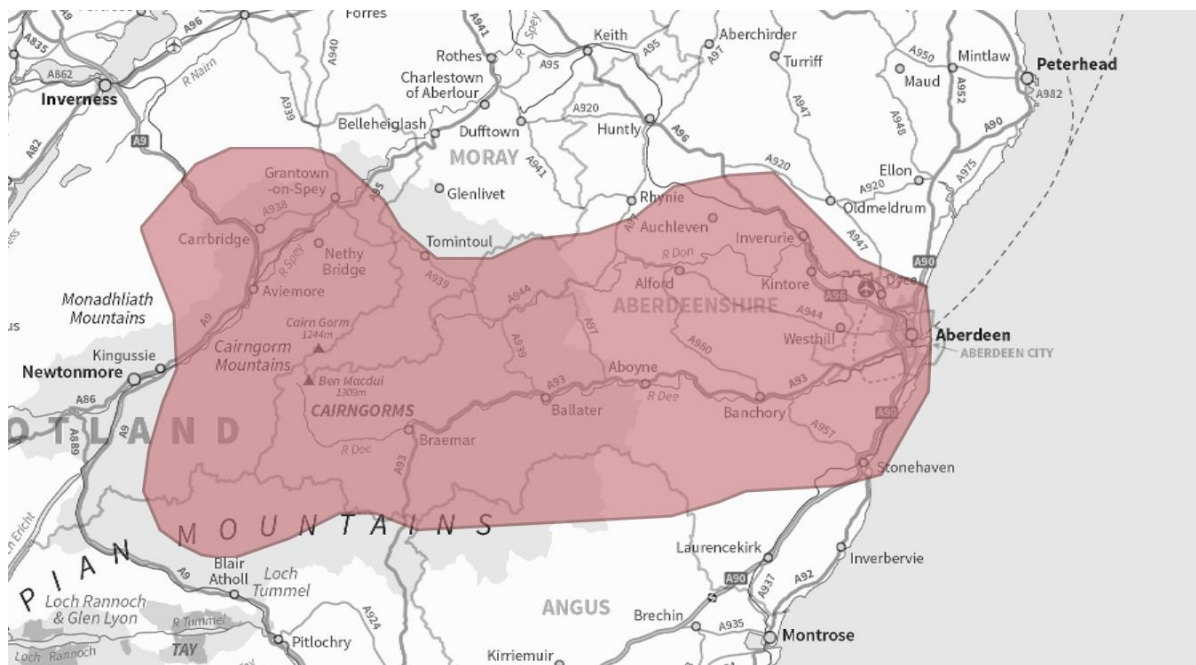

Image: Dr Alistair McCay

**Figure 40 – maximum area in which heat demand could be met from geothermal heat from radiothermal granites**

We have interrogated the heat map database and established that the annual heat demand in this area is 6.4 TWh – very similar to the total geothermal heat capacity that we estimated above.

On first inspection this is a happy coincidence, though we must exercise caution. The 6.4 TWh figure will include heat demands at temperatures geothermal heat cannot supply (for example, in industrial processes). Furthermore there will be periods of high demand when the geothermal sources (which are characterised by constant, unvarying heat production) are not able to cover the peaks – just as our financial model at Banchory demonstrates.

<sup>16</sup> <http://www.gov.scot/Resource/0044/00444530.pdf> P. 47.

Assuming good use is made of heat stores (again, as is the case at Banchory) it should be possible to meet the *majority* of this heat demand. As a conservative estimate we assume a figure of 70%.

In conclusion, we assume that 70% of the 6.4 TWh = approximately 4.5 TWh, or 5.2% of total Scottish heat demand.

We would again note that we have only considered the potential for deep geothermal heat from radiothermal granites. There may be just as much or more potential to exploit deep geothermal heat to meet demand elsewhere in Scotland, including the central lowlands where the majority of the heat demand is located.

### **Converting heat production into carbon savings**

Most of the heat consumers across the selected area will be from natural gas, though a significant proportion – given that much of it is off the gas grid – will use heating-oil. The relative carbon intensities of these heating technologies are:

natural gas heating: 184.5 KgCO<sub>2</sub>/MWh

heating oil: 246.6 KgCO<sub>2</sub>/MWh.

These figures come from the Defra tables mentioned above.

Robust data are hard to locate, but we note that while purely in terms of square kilometres most of our selected area is off the gas grid, the majority of the population within it (living in the urban areas around Aberdeen) will use gas central heating. We should thus assume a figure that is closer to the lower, natural gas figure – the obvious round figure being 200 KgCO<sub>2</sub>/MWh.

(We note in passing that we have not considered the scope for replacing *electrical* heating with deep geothermal heat – which for the foreseeable future would yield a larger carbon emission saving per unit of heat delivered than gas and heating oil.)

The amount of carbon generated by meeting 4.5 TWh of heat using a technology with 200 KgCO<sub>2</sub>/MWh is:

$$200 \times 4.5 \times 1,000,000 = 900,000,000 \text{ Kg.}$$

In other words, we estimate the potential carbon abatement from using radiothermal granites is around **900,000 tonnes of CO<sub>2</sub> per year**.

## 16. Community Engagement

Geothermal district heating has not been employed on any significant scale in Scotland, though there are estimated to be more than 240 schemes in Europe producing 12,900GWh of renewable heat<sup>17</sup>. With very limited experience of geothermal energy HOBESCO sought the views of the community, holding an event for local people to find out more about both the existing Hill of Banchory Biomass Heat Network and the work of this geothermal feasibility study. Attendees of the event, as well as existing HOBESCO customers, were invited to complete a questionnaire, the results of which are shown below.

*Question 1 – What is your level of knowledge of geothermal energy?*

64% of respondents claimed to have a medium level of geothermal knowledge, surprisingly high given the low level of geothermal energy in Scotland, though during discussions it was apparent that most people have only a very basic understanding. 36% stated a low level of knowledge. Nobody claimed to have a high knowledge level.

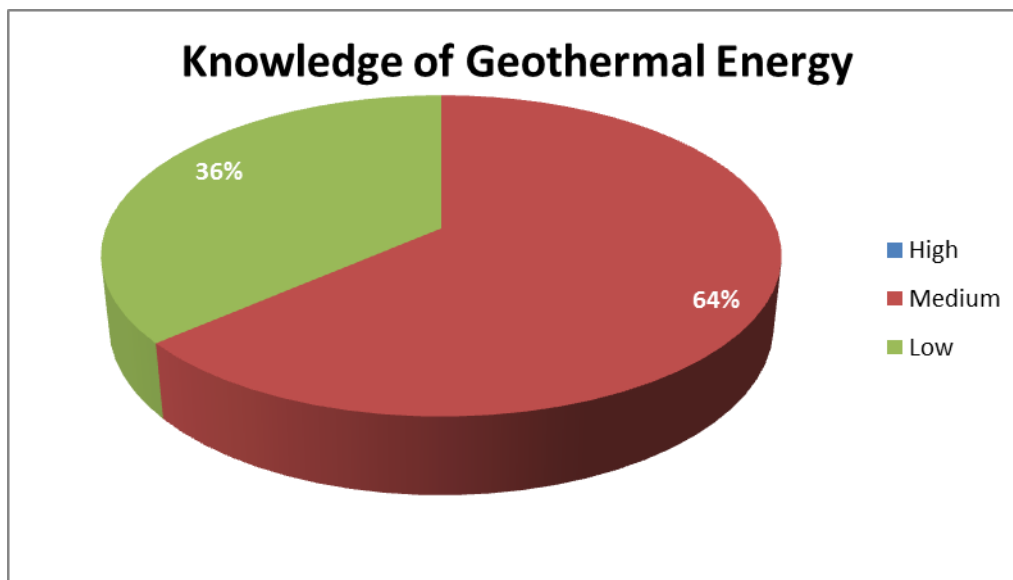

*Question 2 – Do you support the development of geothermal energy in Scotland?*

All respondents supported the development of geothermal energy in Scotland. One commented;

*'We need a demonstration plant in Scotland as soon as possible.'*

Another stated;

*'It is interesting that Aberdeenshire seems to be well suited to using geothermal heat and could be an ideal area for its development. Quite exciting.'*

<sup>17</sup> <http://geodh.eu/>

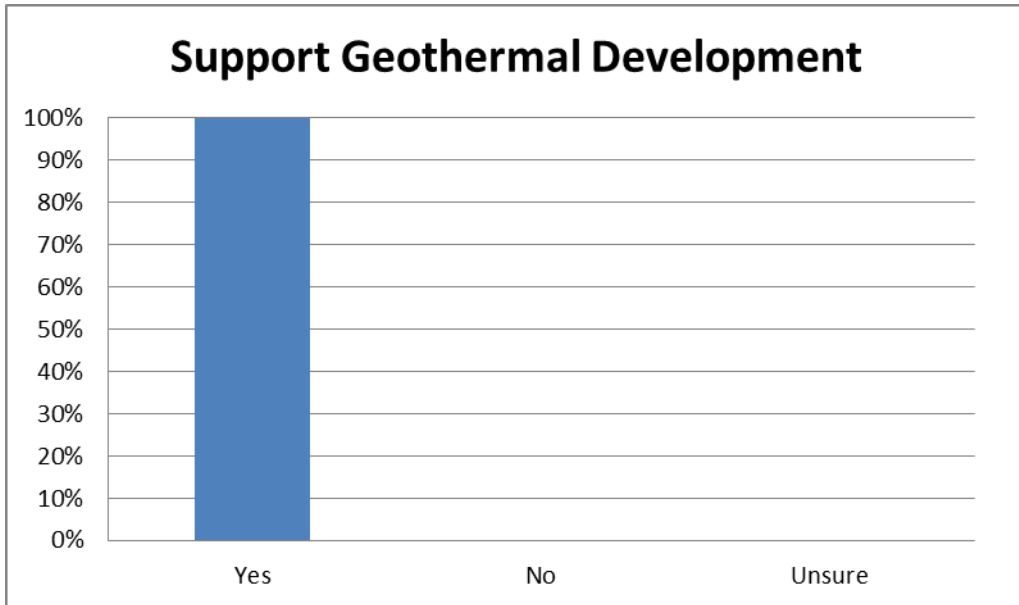

*Question 3 – Should development of geothermal energy be supported by government?*

100% of respondents stated that geothermal energy requires government support. People understand how geothermal energy might benefit the country and want to see how we might realise its potential.

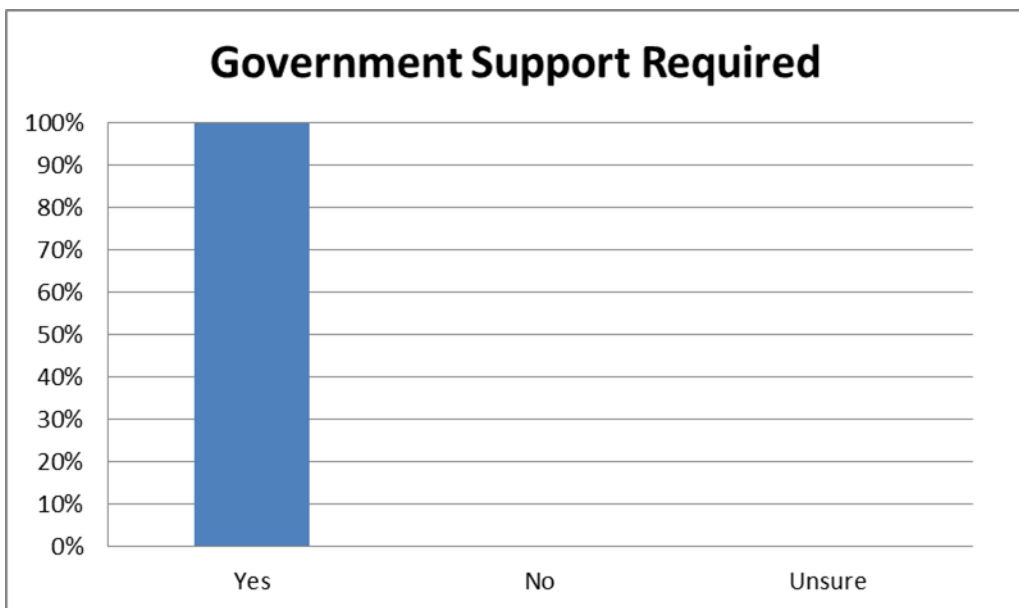

*Question 4 – would you be happy to receive your heat from geothermal energy?*

Despite very limited use of geothermal energy in Scotland, all respondents stated they would be happy to receive their heat from geothermal energy. One respondent was concerned about fracking, and whilst the method of heat extraction is not the same as fracking, the negative public image of fracking needs to be addressed whilst developing geothermal energy. General acceptance by the public of renewable energy technologies over the past decade should outweigh any perceptions of association with fracking.



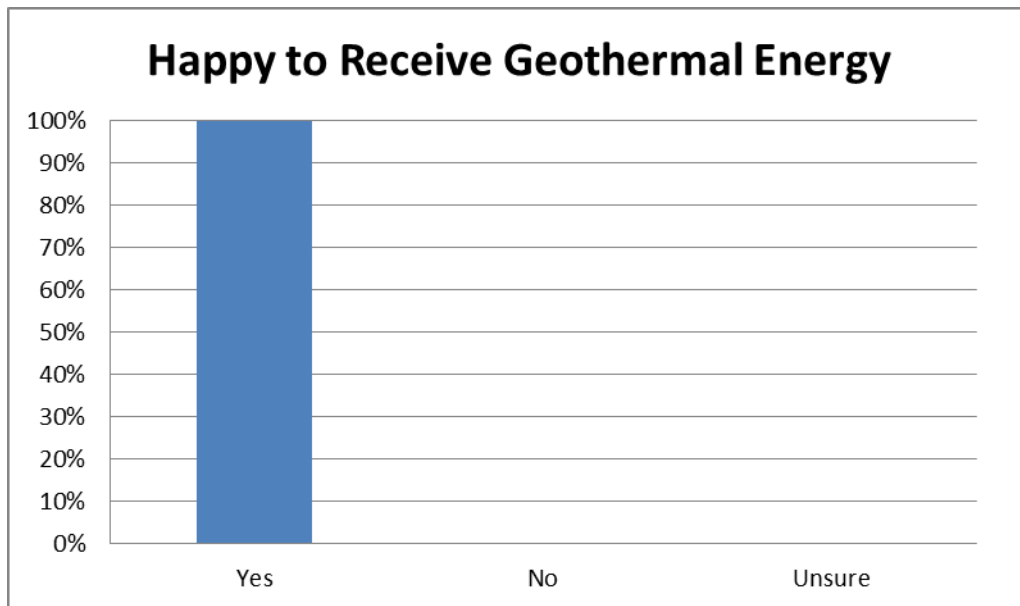

### Aberdeenshire Council

Scottish Government has targeted an additional 40,000 homes to be connected to Heat Networks by 2020, and local authorities will be a key enabler in achieving this goal. However, following the most recent meeting of the Scottish Heat Network Practitioners Group, the lead organisation, Heat and The City, concluded that the capacity of local authorities to coordinate users is weak, and their appetite to do so is driven by enthusiastic individuals. Heat and The City concluded that in order to drive a 'step change' in heat decarbonisation, which district heating can support, requires a shift from standalone projects to a more comprehensive programme of system change. This change needs to be driven by central Government, providing local government and commercial organisations with the tools and resources to facilitate that change, an example being the implementation of funded District Heating Officers.<sup>18</sup>

The Council's involvement is vitally important for an expanded Heat Network at Hill of Banchory given that public buildings would be potentially large consumers of heat, and buildings such as schools and care homes provide key anchor loads, crucial in operating efficient systems. Initial discussions with Aberdeenshire Council have met with a positive response, and the future success of an expanded geothermal network would require their active participation.

<sup>18</sup> <http://www.heatandthecity.org.uk/about/?a=187208>.

## 17. Conclusion and Recommendations

The work reported here has confirmed that there is indeed a promising prospect for augmenting the heat supplied to the customers of the Hill of Banchory heat network by developing a deep geothermal well doublet system exploiting the radiothermal Hill of Fare granite nearby. Appraisal of pre-existing geological data, and new data on heat production rates and thermal conductivity gathered during this study, reveal that the Hill of Fare Pluton is somewhat more promising as a geothermally prospect than had hitherto been supposed.

The HOBESCO network is unusually cost-effective as it sources its biomass locally, and geothermal energy would not be able to out-compete that energy source. However, financial appraisal indicates that it could out-compete the use of gas (which is already used or back-up and peak-up purposes by HOBESCO), and would be an attractive alternative to gas to support future network expansion once the limits of local sustainable biomass availability are exceeded. In otherwise analogous situations elsewhere in Scotland where cheap, sustainable local biomass is not available, geothermal from similar granites would likely emerge as the prime option for low-carbon, renewable district heating.

Given the limited time and funds available for this project, it has not been possible to eliminate all sources of uncertainty relating to the Hill of Fare / Hill of Banchory geothermal prospect. In particular, we lack site-specific information on several important aspects of hydrogeology and geothermics, including:

- the geothermal gradient within the Hill of Fare;
- possible decrease in heat production rates over depth, and the rate thereof;
- fracture patterns in the granite;
- permeability of fractured zones; and
- chemistry of native ground water at depth in the granite (which has implications for corrosion control and reinjection practices).

This study has markedly increased confidence in the viability of developing renewable heat from Scotland's radiothermal granites. It has made ever more poignant and pressing the need to finally catch up with other parts of the UK with similar prospects (i.e. Cornwall and the North Pennines) and sink some boreholes to resolve some of the above questions in a rigorous and timely manner. The next steps for the Hill of Banchory project (see Chapter 19) are therefore focused on addressing this need, and removing the principal remaining barrier to project development for this promising source of low-carbon, renewable heat.

## 18. Strategic Implications of a Banchory Geothermal Project

While it has long been appreciated that the Eastern Grampian granite plutons of Scotland represent a potential source of energy, no specific proposals have yet reached the stage at which this project has now placed the Hill of Fare pluton. This has only been realised in this case because of the pre-existence of a successful heat network at Hill of Banchory, which has facilitated concrete consideration of quite what it would take to harness geothermal heat from granite for district heating purposes. This project is therefore, in itself, a strategic development in the context of Scotland's wider quest for affordable low-carbon and renewable heat.

Clearly there is scope to use this project's findings as a template for similar, site-specific appraisals of the prospects for community and industrial (e.g. for whisky production) use of the heat in similar (and in many cases even more promising) granites elsewhere in Aberdeenshire and adjoining districts. Most of the towns in this region are not connected to the gas grid, and there is not scope in all of them to exploit sustainable local wood supplies for biomass-based district heating. Geothermal probably represents the single best hope of simultaneously combatting fuel poverty and carbon emissions from heat in those towns. As demonstrated in Chapter 15, this could amount to 70% or more of the total heat demand in this region, and in excess of 5% of the total heat demand of Scotland.

In addition, there are other regions of Scotland where radiothermal granites may be present in the deep subsurface (e.g. xenoliths in volcanic plugs in the Midland Valley include notable examples of suitably potassium-rich granites, indicating the likely presence of plutons of that nature at depth; see Younger *et al.* 2012). Indeed, the occurrence of such granites at depth might explain the relatively high heat flows in the sedimentary basins of the Midland Valley, providing a link to the Deep Sedimentary Aquifer prospects in that region.

If the Banchory project is taken to the next stage (see Chapter 19), the strategic value for Scotland will be considerable. But the strategic value will also extend into adjoining regions (e.g. the North Pennines and Lake District of England, where similar granites have been investigated in recent years) as well as into Northern Ireland, where the Mourne Granite has recently been recognised as an exceptionally high heat-producer.

Wider afield, the European Union continues to invest considerable sums in geothermal R&D, such as the Horizon 2020 DESTRESS project which commences on March 1<sup>st</sup> 2016 (in which the University of Glasgow participants in this consortium are the UK partners), which is addressing optimal reservoir stimulation techniques for radiothermal granites and other deep geothermal prospects. Thus timely execution of the proposed next steps of this project would allow Banchory, and therefore Scotland, to contribute at the very forefront of European (and thus global) R&D and demonstration of geothermal energy technology.

## 19. Next Steps

This project has strongly supported the hypothesis that the Hill of Fare granite could be successfully exploited to provide low-carbon renewable heat to augment and support expansion of the existing Hill of Banchory district heating network. The results are sufficiently encouraging that they justify seeking funding to sink one or more pilot boreholes and to expand geophysical prospecting around the Hill of Fare pluton. In parallel, further engagement with local landowners and with the public ought to be undertaken, so that if the results of the geoscientific work are favourable, the way will be clear to begin to develop specific plans to drill a production and reinjection borehole doublet system.

Accordingly, the next steps to take forward the Hill of Banchory Geothermal Project would be as follows. We assume that the next phase of the project would be predicated on the continuation of the current consortium, which would engage third parties with the relevant expertise to assist as necessary. We also expect that some of the consortium members would in time form the core of a 'Banchory Geothermal Energy Services Company' (ESCO). We anticipate that Aberdeenshire Council would play an increased role as the project developed and a robust business plan was worked up.

The consortium members make clear that their ultimate objective is creating a geothermal borehole doublet at Hill of Fare that will supply low carbon, renewable heat to customers in Banchory. The steps above are designed to take the project to the point where a fully robust business case can be produced for this high profile project.

We note that an essential element in the development of a deep geothermal well at Banchory will be the presence of a suitable heat customer. An expansion of the heat network in Banchory offers the most obvious way to deliver this. This would facilitate the wider deployment of renewable heat and align with Scottish Government's targets on district heating. We expect Aberdeenshire Council to play an important role in this process, not least because they oversee several large individual heat customers in Banchory.'

We have made indicative estimates of timelines and budget required for each task (*italics*).

1. Procure funding and relevant permits (most notably from the Scottish Environmental Protection Agency and the local planning authority) to facilitate the actions at point 2.

*We expect obtaining regulatory permission for the pilot drilling to take 3-6 months. There is nothing particularly unusual in the drilling being proposed, so this should be relatively straightforward. On this assumption, costs of £5-10K0 should cover administrative effort.*

2. Drill, sample (using cuttings and spot coring), case, geophysically log and test-pump at least one (and ideally three) pilot boreholes completed to depths of 600m – 1000m (i.e. deep enough to extend below the weathering zone and largely below the zone of palaeoclimatic influence). Consider retaining the completed borehole(s) for future piezometric and micro-seismic monitoring.

*Drilling each pilot hole should take around 3 months, including well pad preparation and site reinstatement. Preceding this, a procurement exercise to select a drilling company could take 2-4 months. Boreholes drilled into granite are relatively rare, but the 995 m deep*

*borehole drilled into the Weardale granite in County Durham in 2004 cost £460K. Test pumping and other analysis could take up to 1 month, and cost (again to judge from Eastgate test-pumping in 2006) up to £50K per borehole, depending on the precise regime devised from the findings of the drilling and geophysical logging.*

It should be noted that, following completion of the above works, the three boreholes would be retained for possible future re-use for monitoring of supra-reservoir water pressures, temperatures and micro-seismicity in the event the future production and reinjection boreholes are commissioned. Hence the investment in this phase of the work would create some reusable assets in addition to essential data.

3. In parallel, complete surface geophysical surveys (gravity, passive seismic etc.) should be carried out. On a longer timescale, work should be undertaken to improve our understanding of the natural fracture networks in the granites and their associated hydraulic conductivities. This would include LIDAR fracture surveys of the exposed granites in the Hill of Fare quarries.

*The costs for a geophysical survey, the fracture network analysis, experiments of granite failure and coupled numerical simulations would be around £200K. Initial results could be generated within 6-12 months, with a fuller academic study extending into the medium term.*

4. Develop a detailed plan and schedule for the drilling, logging, testing and commissioning of the permanent production and reinjection boreholes.

This would be carried out by the consortium members, assisted as necessary by specialist consultancy advice. Estimated cost £30-50K, timescale 6-12 months. The input from the consortium would perhaps be on a similar scale to the first phase of the project.

The following tasks would be carried out by consortium members, with the transition to an ESCO in mind.

5. Liaise with local landowners over the possibility of agreeing sites for production and reinjection boreholes and wayleaves for pipelines to take water to / from the existing Hill of Banchory energy centre.

6. Run further public engagement events locally, regionally and nationally, including opportunities for the public to experience drilling at first hand during (2) above.

7. Initiate the search for investment to allow the project to proceed.

*These tasks are unlikely to require significant non-wage costs, but would involve extensive input of employee time for consortium members. We estimate these tasks will take 2-4 months, and will cost £50-75K.*

## References

- AECOM (2013) - *Study into the Potential for Deep Geothermal Energy in Scotland*, Scottish Government paper – online at <http://www.gov.scot/Resource/0043/00437977.pdf>
- Baisch, S., Weidler, R., Vörös, R., Wyborn, D. and de Graaf, L., 2006. Induced seismicity during the stimulation of a geothermal HFR reservoir in the Cooper Basin, Australia. *Bulletin of the Seismological Society of America*, 96(6), pp.2242-2256.
- Barton, C.A., Zoback, M.D. and Moos, D., 1995. Fluid flow along potentially active faults in crystalline rock. *Geology*, 23(8), pp.683-686.
- Black, J.H., Barker, J.A. and Woodman, N.D., 2007. *An investigation of sparse channel networks'. Characteristic behaviours and their causes*. Swedish Nuclear Fuel and Waste Management Co.
- British Geological Survey. 1992. Inverurie. Scotland Sheet 76E. Bedrock. 1:50 000 Geology Series. Keyworth, Nottingham.
- British Geological Survey, 2002. Inverurie. Scotland Sheet 76E. Solid and Drift Geology. 1: 50 000. Keyworth, Nottingham.
- Busby, J., Gillespie, M. and Kender, S., 2015. How hot are the Cairngorms?. *Scottish Journal of Geology*, 51(2), pp.105-115.
- Chabora, E., Zemach, E., Spielman, P., Drakos, P., Hickman, S., Lutz, S., Boyle, K., Falconer, A., Robertson-Tait, A., Davatzes, N.C. and Rose, P., 2012, January. Hydraulic Stimulation of Well 27-15, Desert Peak Geothermal Field, Nevada, USA. In *Proceedings of thirty-seventh workshop on geothermal reservoir engineering*, Stanford University, Stanford (Vol. 30).
- Dezayes, C., Genter, A. and Valley, B., 2010. Structure of the low permeable naturally fractured geothermal reservoir at Soultz. *Comptes Rendus Geoscience*, 342(7), pp.517-530.
- Donofrio, R.R., 1998. North American impact structures hold giant field potential. *Oil and Gas Journal*, 96(19), pp.69-83.
- Downing, R.A. and Gray, D.A. 1986 *Geothermal Energy – The potential in the United Kingdom*. London: Her Majesty's Stationary Office
- Evans, K.F., Moriya, H., Niitsuma, H., Jones, R.H., Phillips, W.S., Genter, A., Sausse, J., Jung, R. and Baria, R., 2005. *Microseismicity and permeability enhancement of hydrogeologic structures during massive fluid injections into granite at 3 km depth at the Soultz HDR site*. *Geophysical Journal International*, 160(1), pp.388-412.

Gérard, A., Baumgartner, J., Baria, R., Jung, R., Gentier, S. and Genter, A., 2002. Elements for a conceptual model of the underground heat exchanger at Soultz-sous-Forêts, France. Situation, beginning 1998. In *Proceedings of the 4th International HDR Forum in Strasbourg (1998)*, *Geologische Jahrbuch Reihe E Geophysics Heft SE1, Hannover* (pp. 281-290).

Gillespie, M. R., Crane, E.J. and Barron, H.F. 2013. Study into the Potential for Deep Geothermal Energy in Scotland: Volume 2. ISBN: 9781782569862 (web only publication, available from <http://www.gov.scot/Publications/2013/11/6383>)

Johnston, Euan, 2015. Potential field data in NE Scotland and its preliminary interpretation. *Unpublished MSc Research Report, School of Geosciences, University of Aberdeen.*

Jupe, A.J., Green, A.S.P. and Wallroth, T., 1992, July. Induced microseismicity and reservoir growth at the Fjällbacka hot dry rocks project, Sweden. *International Journal of Rock Mechanics and Mining Sciences & Geomechanics Abstracts* (Vol. 29, No. 4, pp. 343-354).

Kearey, P., Brooks, M. and Hill, I., 2002. *An Introduction to Geophysical Exploration.* Blackwell.

Kyriakis, S.A., and Younger, P.L. (2016) Towards the increased utilisation of geothermal energy in a district heating network through the use of a heat storage. *Applied Thermal Engineering*, 94, (5): 99–110

Li, B., Guttormsen, J., Hoi, T.V. and Duc, N.V., 2004, January. Characterizing permeability for the fractured basement reservoirs. In *SPE Asia Pacific Oil and Gas Conference and Exhibition.* Society of Petroleum Engineers.

Majer, E.L., Baria, R., Stark, M., Oates, S., Bommer, J., Smith, B. and Asanuma, H., 2007. Induced seismicity associated with enhanced geothermal systems. *Geothermics*, 36(3), pp.185-222.

Manning, D.A.C., Younger, P.L., Smith, F.W., Jones, J.M., Dufton, D.J. and Diskin, S., 2007. A deep geothermal exploration well at Eastgate, Weardale, UK: a novel exploration concept for low-enthalpy resources. *Journal of the Geological Society*, 164(2), pp.371-382.

McCay, A.T., Harley, T.L., Younger, P.L., Sanderson, D.C. and Cresswell, A.J., 2014. Gamma-ray spectrometry in geothermal exploration: State of the art techniques. *Energies*, 7(8), pp.4757-4780.

McGregor, D.M. and Wilson, C.D.V., 1967. Gravity and magnetic surveys of the younger gabbros of Aberdeenshire. *Quarterly Journal of the Geological Society*, 123, 99-120.

Richards, H.G., Parker, R.H., Green, A.S.P., Jones, R.H., Nicholls, J.D.M., Nicol, D.A.C., Randall, M.M., Richards, S., Stewart, R.C. and Willis-Richards, J., 1994. The performance and characteristics of the experimental hot dry rock geothermal reservoir at Rosemanowes, Cornwall (1985–1988). *Geothermics*, 23(2), pp.73-109.

Olkiewicz, A., Gale, J.E., Thorpe, R. and Paulsson, B., 1979. Geology and Fracture System at Stripa Lawrence Berkeley Lab. *Report LBL, 7079.*

Tandom, P.M., Ngoc, N.H., Tjia, H.D. and Lloyd, P.M., 1999, January. Identifying and evaluating producing horizons in fractured basement. In *SPE Asia Pacific Improved Oil Recovery Conference*. Society of Petroleum Engineers.

Thomas, C.W., Gillespie, M.R., Jordan, C. and Hall, A.M. (2004). *Geological structure and landscape of the Cairngorm Mountains*. Scottish Natural Heritage Commissioned Report No.064 (ROAME No. F00AC103).

Westaway, R. and Younger, P.L., 2013. Accounting for palaeoclimate and topography: a rigorous approach to correction of the British geothermal dataset. *Geothermics*, 48, pp.31-51.

Wyborn, D., 2010, April. Update of development of the geothermal field in the granite at Innamincka, South Australia. In *Proceedings of the World Geothermal Congress, Bali, Indonesia* (pp. 25-30).

Wheildon, J, Lee M. K., Webb, P. C., Brown, G. C., Rollin, K. E., Crook, C. N., ... & Thomas-Betts, A. (1984). *HDR prospects in Caledonian granites: evaluation of results from BGS-IC-OU research programme (1981-84)*. Invest. Geothermal Potential UK, 83pp., BGS

Younger, P.L., 2014. Missing a trick in geothermal exploration. *Nature Geoscience*, 7(7), pp.479-480

Younger, P. (2015). *Geothermal Energy: Delivering on the Global Potential*. Guest editor of Special Issue. *Energies*, 7.

Younger, P. L., Gluyas, J. G., & Stephens, W. E. (2012). *Development of deep geothermal energy resources in the UK*. *Proceedings of the Institution of Civil Engineers-Energy*, 165(1), 19-32.

Younger, P. L., & Manning, D. A. C. (2010). *Hyper-permeable granite: lessons from test-pumping in the Eastgate Geothermal Borehole, Weardale, UK*. *Quarterly Journal of Engineering Geology and Hydrogeology*, 43(1), 5-10.



## Appendices

## Appendix 1 – Thermal Conductivity Data

Sample	Locality	Locality Grid Ref	Orientation	Field Notes	Hand Specimen Description	Laboratory Notes	Thickness (mm)	Thermal Conductivity (W/mK)
HoF - 01	L1A Raemoir - Main Quarry	NJ 70143 00363	345 - 80	Top of main quarry NE cliff face	Orangy pink granite - medium grained (up to 5mm), no foliation, granular, rich in pink orthoclase and quartz, orthoclase (45%), quartz (30%), plagioclase (20%) mica (5%)	Chip on top edge from rock saw (due to pre existing fracture) - roughly 10mm in length, <10mm <sup>2</sup> surface area. Continuous fracture down one edge and across some of the top.	9.94	3.284
HoF - 02	L1A Raemoir - Main Quarry	NJ 70143 00363	062 - 83	3m below HoF - 01	Orangy pink granite - medium grained (up to 5mm), no foliation, granular, rich in pink orthoclase and quartz, orthoclase (40%), quartz (30%), plagioclase (25%) mica (5%)	Sample is slightly tapered.	10.99	2.995
HoF - 03	L1A Raemoir - Main Quarry	NJ 70143 00363	110 - 87*	5m below HoF - 02. *sample came loose before orientation taken*	Orangy pink granite - medium grained (up to 5mm), no foliation, granular, rich in pink orthoclase and quartz. Slightly less quartz than HoF 1 and 2, orthoclase (50%) quartz (25%), plagioclase (20%) mica (5%)	Slight chip on top edge - surface area ~1mm <sup>2</sup> .	10.11	3.213
HoF - 04	L1B Raemoir - Northern Quarry	NJ 70105 00477	350 - 96*	Top of northern quarry N cliff face. *loose*	Lighter pink than Raemoir Main Quarry (more plagioclase) - coarse grained (up to 7mm), no foliation, orthoclase (40%) plagioclase (30%) quartz (20%) mica (10%)	Nothing to note.	7.26	2.349
HoF - 05	L1B Raemoir - Northern Quarry	NJ 70105 00477	168 - 80*	3m down and 10m across on S side outcrop. *loose*	Lighter pink than Raemoir Main Quarry (more plagioclase) - coarse grained (up to 7mm), no foliation, orthoclase (40%) plagioclase (25%) quartz (25%) mica (10%)	Slightly chipped top and bottom edges from rock saw.	8.17	2.803
HoF - 06	L1B Raemoir - Northern Quarry	NJ 70105 00477	348 - 90	8m E of HoF - 04, 2m down from weathered surface	Lighter pink than Raemoir Main Quarry (more plagioclase) - coarse grained (up to 7mm), no foliation, orthoclase (40%) plagioclase (30%) quartz (20%) mica (10%)	Large chip on side of sample - roughly 10mm <sup>2</sup> surface area.	11.67	3.004
HoF - 07	L1B Raemoir - Northern Quarry	NJ 70105 00477	335 - 81	0.5m from HoF - 06	Lighter pink than Raemoir Main Quarry (more plagioclase) - coarse grained (up to 6mm), no foliation, orthoclase (40%) plagioclase (30%) quartz (20%) mica (10%)	Nothing to note.	8.10	2.955
HoF - 08	L2A The Skairs - Weathered Outcrop	NJ 689 014*	084 - 19*	15m from x2 wooden posts near summit. *sample loose and broken into pieces*	Light grey/ pink microgranite (crystals <1mm) - no foliation, plagioclase (35%) orthoclase (30%) quartz (25%) mica (10%)	Nothing to note.	9.50	2.697
HoF - 09	L2B The Skairs - Weathered Outcrop	NJ 689 014*	232 - 04	30m across and 10m down SE from HoF - 08	Dark grey granite - medium grained (sub mm to 4mm), no foliation, plagioclase (35%) quartz (35%) orthoclase (25%) mica (5%)	Slight chip on top and bottom edge (1mm <sup>2</sup> surface area each).	10.48	3.133
HoF - 10	L2C The Skairs - Weathered Outcrop	NJ 689 014*	250 - 78	10m SE from HoF - 09, by x2 trees	White/ pink granite - coarse grained (up to 7mm), no foliation, plagioclase (40%) quartz (30%) orthoclase (20%) mica (10%)	Sample is slightly tapered.	10.14	2.601
HoF - 11	L3A Craighton - Main Quarry	NJ 71102 00530	051 - 67*	SW edge of quarry, top of cliff face on weathered surface. *loose and broken*	Orangy pink granite - coarse grained (up to 5mm), no foliation, orthoclase (60%) quartz (30%) plagioclase (5%) mica (5%)	Nothing to note,	9.41	3.072
HoF - 12	L3A Craighton - Main Quarry	NJ 71102 00530	340 - 13	0.5m from HoF - 11 taken vertically down	Orangy pink granite - medium grained (up to 5mm), no foliation, orthoclase (55%) quartz (30%) plagioclase (10%) mica (5%)	Nothing to note	8.54	3.256
HoF - 13	L3A Craighton - Main Quarry	NJ 71102 00530	253 - 09	Vertical sample next to swimming spot on S edge of quarry	Orangy pink granite - medium grained (up to 6mm), no foliation, orthoclase (60%) quartz (30%) plagioclase (5%) mica (5%)	Nothing to note.	9.10	3.346
HoF - 14	L3A Craighton - Main Quarry	NJ 71102 00530	073 - 89*	Taken from large boulder on E of quarry edge. *loose and broken*	Dark orangy pink granite - medium grained (up to 5mm), no foliation, orthoclase (60%) quartz (35%) plagioclase (5%)	Nothing to note.	11.01	3.279
HoF - 15	L3B Craighton - Northern Quarry	NJ 70885 00628*	261 - 89*	Taken from half way up 1.5m high cliff. Small plug due to petrol shortage. *loose and broken*	Light pink granite - medium grained (up to 5mm), no foliation, orthoclase (50%) quartz (25%) plagioclase (20%) mica (5%)	Sample is slightly tapered.	7.60	3.071
HoF - 16	L3C Craighton - Southern Quarry	NJ 70885 00628	109 - 76*	E side of quarry mouth, very hard outcrop. *loose and broken*	Light pink granite - medium grained (up to 5mm), no foliation, orthoclase (60%) quartz (25%) plagioclase (10%) mica (5%)	Slightly small and irregular sample	7.89	2.176
HoF - 17	L3C Craighton - Southern Quarry	NJ 70885 00628	115 - 78	0.5m down and S of HoF - 16	Pink granite - medium grained (up to 4mm), no foliation, orthoclase (55%) quartz (25%) plagioclase (15%) mica (5%)	Only thin sample could be produced	6.04	3.682
HoF - 18	L3C Craighton - Southern Quarry	NJ 70885 00628	263 - 86	W side of quarry mouth, 20m W of HoF - 16/17, drill stopped working so plug small	Dark pink granite - medium grained (up to 5mm), no foliation, orthoclase (60%) quartz (30%) plagioclase (5%) mica (5%)	Sample is slightly irregular in shape	13.48	3.305

## Appendix 2 – Network Heat Cost Model Input Variables

Network Operator Input Variables	
Lifespan (Years)	This is the financing lifetime of the district heating network. The network is expected to have a lifetime of 50 years, however it is considered highly unlikely that a financial institution would be willing to invest for longer than 25 years.
Connection Charge	A charge to customers on the network that can be varied to wholly or partially cover the costs of the Heat Interface Units, or completely negated.
Pipe Cost (£/m)	The cost of heat network is a key variable and will be influenced by the pipe specification, trenching costs (i.e. hard/soft dig), land and wayleave costs and other factors. £800/m has been taken as the weighted average cost of pipe, based on more accurate designs for similarly sized projects.
Discount Rate	The model assumes that the network is financed as a load and the repayments based on constant payments and a constant interest rate. A set of financing scenarios have been suggested in the model for the user to choose from.
Operators Margin	The network operator would expect to make a return on heat sales and this has been assumed at 10.0% of the heat sales revenue.
OPEX Expenditure	The cost of operating the network is expected to be fairly modest and has been assumed to be 1.0% based on Ramboll's previous experience.

## Appendix 3 – Risk Register

#	Risk	Area	Risk = Prob * Impact	Manage ability	Mitigating actions	When to address risk	Risk after mitigation
1	There is insufficient water yield at depth to be viable, due to insufficient fracture permeability or connectivity	subsurface	H	L	1. Evaluate and make case for stimulation to improve flow rates 2. evaluate completing a a closed loop system 3. Evaluate completing as a low flow system 4. Abandon the well and Supply heat to expanded DHN from alternate sources, eg biomass, gas 5. consider maintaining well for research	Post drilling	M
3	Rock - water reactions reduce permeability over time, reducing well productivity	subsurface	M	L	Monitor well performance and conduct laboratory experiments and modelling based on measured rock mass conditions to understand and predict rock-water reactions, and on this basis design mitigating interventions (eg Stimulation) if necessary.	Post drilling	L
4	Produced Water quality impacts on equipment costs and maintenance	subsurface	M	M	1. Sample Water in test bore to design metallurgy appropriately 2. Test water in production well and develop maintenance strategy	Test Bore or Post Drilling	L
5	Microgranites may be present at depth complicating heat profile and so well performance prediction	subsurface	L	L	None		L
6	Over-reliance on a single geological model leads to well missing target	subsurface	H	H	Be aware of model risk when defining well location	Next stage	L
7	Well flows at lower temperature than expected	subsurface	M	L	1. Measure downhole temperature in test bore 2. Evaluate options to deepen the well for higher temperature 3. Assess District heating network alternatives for lower temperature input	Next Stage & Test Bore	M
8	Thermal breakthrough from injection well	subsurface	M	L	Cease injection, sidetrack injector? No pre-drill mitigation	Post drilling	M
9	Drilling costs exceed plan due to drilling challenges	Well	M	M	Given lack of offset wells consider test bore to evaluate tophole conditions	Next Stage & Test Bore	M
10	Difficulty obtaining wayleaves for heat pipeline	Well to DHN	M	H	Work with landowners to optimise pipeline route	Next stage	L
11	Difficulty obtaining planning permission for pipeline and well surface infrastructure	Well to DHN	L	H	Work with landowners and Planning Authority to optimise pipeline route	Next stage	L
12	Difficulty obtaining landowner permission for a drilling pad	Well	L	H	Work with landowners	Next stage	L
13	New public sector buildings not compatible with District Heating Network, eg delivery temperatures	DHN	M	M	Engage with Aberdeenshire Council early to influence design	Next stage	L
14	District Heating Network return temperature too high	DHN	H	M	Evaluate alternatives, eg heat pumps, higher well temperatures through deeper well	Next stage	M
15	Private sector housing not interested in District Heating Network, especially retrofit in Banchory centre	DHN	M	M	Engage with local stakeholders to demonstrate the economic value, carbon savings etc,	Next stage	L
16	No Government Grant for well capex	Finance	M	M	Seek alternatives: private sector; well insurance scheme, etc	Next stage	M
17	Can't compete with current cost of gas to Aberdeenshire Council at 2.5p/kwh	Finance	M	M	Structure pricing to compete long term, offer CO2 reduction, be prepared to reduce price for large user	Next stage	L
18	No Government funding for Stage 2 of project	Finance	M	M	Lobby for continued funding to reach investment decision	Next stage	M
19	RHI abolished or cut back	Finance	H	L	Lobby	Next stage	M
20	Cost of retrofit to existing properties too high	Finance	M	M	Optimise retrofit design and costs, seek funding for energy efficiency investments	Next stage	M
21	Scottish Government imposes a moratorium on reservoir development for geothermal due to wider concerns about fracking	Stakeholders	H	M	Lobby	Next stage	M
22	Lacking general public support locally	Stakeholders	L	M	Manage all local stakeholders with long term engagement plan	Next stage	L
23	Other Geothermal heat projects fail, with knock on	Stakeholders	M	L	Demonstrate why our project is different? (if it is!)	Next stage	M

## Appendix 4 – Heat Production Data for the Hill of Fare Granite

Location	Grid Square	North	South	K (wt%)	U (ppm)	Th (ppm)	Heat Production (uW/m <sup>3</sup> )	Corrected Heat Production (uW/m <sup>3</sup> )	Notes
Raemoir Quarries	NJ	70174	00374	5.48	8.15	28.37	4.643919	3.813437135	On face of quarry at initial step down to ledges leading down to the water
				5.07	10.76	25.4	5.080239	4.50908787	
				5.32	8.66	28.21	4.751136	4.018818045	
Raemoir Quarries	NJ	70161	00354	5.37	7.92	36.52	5.145417	4.311801955	Same as above but on a different face
				5.59	8.46	32.1	4.997349	4.022910644	
Craigton Quarries	NJ	71029	00438	6.15	13.53	48.31	7.516044	5.49954439	This is overestimated due to granite boulders at base of vertical exposure
				6.23	13.12	44.41	7.142445	5.159069422	
Craigton Quarries	NJ	70914	00627	5.55	8.41	30.09	4.839372	3.923815135	Smaller northern most quarry of the Craigton quarries. Probably the most accessible quarry face at Craigton
				5.46	10	32.67	5.428404	4.473959341	
				5.37	9.03	32.92	5.183406	4.343636313	
Hill of Fare	NJ	70225	01369	4.17	3.67	24.03	3.042144	-	Isolated exposure in the middle of heather moorland. Granite looks very eroded as blocks are very rounded.
				4.39	4.11	22.29	3.056022	-	
Hill of Fare	NJ	70225	01369	4.27	5.11	24.31	3.448386	-	On different face of exposure to previous measurement
				4.25	4.36	24.76	3.281661	-	
Hill of Fare	NJ	69623	01330	4.27	5.45	22.66	3.421602	-	Photo 0013 likely underestimate
				4.51	5.08	24.37	3.467421	-	
Hill of Fare	NJ	69210	02209	5.35	6.54	21.32	3.715065	-	Small quarry. Plane seems like a fault striking N-S
				4.53	6.28	19.11	3.414339	-	
Crathes Pluton	NO	72896	97348	3.57	1.92	19.22	2.189457	-	Highly fracture/faulted area with possible uranium mobilisation
				3.3	3.73	15.15	2.352267	-	

Crathes Pluton	NO	72896	97348	2.58	3.96	15.19	2.347272	-	Same location as above but different plane
				3.82	2.84	16.17	2.23992	-	
Crathes Pluton	NO	72781	97992	3.08	3.08	12.95	2.006802	-	Underestimate
				3.07	4.04	10.11	2.057913	-	
Craigrath on HoF	NJ	68812	01891	4.1	5.43	23.09	3.430485	-	Just North of Craigrath summit
				4.4	4.41	20.55	3.013389	-	
				4.08	4.38	23.38	3.173958	-	
Craigrath on HoF	NJ	68779	01720	4.44	5.43	22.16	3.397329	-	Similar to above. All outcrops on The Skair and Craigrath are very eroded with rounded edges to all blocks.
				4.43	5.57	23.08	3.497634	-	
The Skairs	NJ	68918	01443	4.28	4.11	22.46	3.057561	-	Underestimate due to topography
				3.52	3.87	24.28	3.050649	-	
The Skairs	NJ	68937	01424	4.6	5.4	25.43	3.634146	-	
				5	5.72	23.43	3.615354	-	
The Skairs	NJ	68960	01416	4.23	3.84	18.97	2.737125	-	
				4.11	5.23	17.4	2.979612	-	
				4.03	4.61	18.94	2.917782	-	
The Skairs	NJ	68844	01389	4.79	6.71	25.91	4.028886	-	Underestimate due to topography
				4.75	4.86	28.44	3.718197	-	
				4.48	6.19	28.28	4.029777	-	
The Skairs	NJ	68898	01335	4.37	14.74	27.72	6.219315	-	
				4.27	13.3	26.55	5.750595	-	
The Skairs	NJ	69070	01301	4.53	5.45	28.38	3.847716	-	
				4.32	5.26	28.11	3.759156	-	
Raemoir Quarries	NJ	70093	00506	4.29	4.87	22.49	3.259656	-	On "flat" surface exposure next to quarry
				4.24	5.19	20.95	3.230631	-	
Raemoir Quarries	NJ	70093	00506	4.86	14.47	31.98	6.493959	6.012925	On quarry exposed surface next to above
				5.54	13.74	29.76	6.211188	5.045188809	

Raemoir Quarries	NJ	70093	00506	5.42	14.58	29	6.366492	5.285832841	On quarry exposed surface next to above
				5.28	14.09	32.58	6.476247	5.519528693	
Raemoir Quarries	NJ	70170	00350	7.14	11.24	45.09	6.783804	4.275506723	Main Raemoir quarry.
				7.35	10.27	41.77	6.316542	3.867270612	
Raemoir Quarries	NJ	70170	00350	4.25	2.69	27.86	3.061908	-	On flat surface at top of Raemoir quarry
				3.74	4.69	24.44	3.297429	-	
Craigton Quarries	NJ	71083	00598	4.97	13.82	28.72	6.105267	5.527907746	On West side of Main Craigton quarry. Possible fault surface.
				5.05	12.82	32.23	6.097329	5.433263465	
Corfieldy Quarry	NJ	67193	001150	4.74	3.2	22.16	2.841642	-	
				4.46	5.17	21.97	3.317787	-	
				4.63	4.77	21.38	3.187674	-	
Corfieldy Quarry	NJ	67314	01216	7.04	8.39	25.48	4.651317	2.973142969	Possible quarry face, or joint hackles causing what looks like faults, overestimated as surrounded by rock
				6.39	7.02	25.13	4.206519	2.962337324	
				6.66	6.79	30.33	4.536837	3.065430405	
Corfieldy Quarry	NJ	67350	01277	4.41	5.16	22.37	3.338523	-	Small quarry uphill from the main flooded quarry
				4.43	3.96	21.04	2.932767	-	
				4.36	3.46	21.15	2.802924	-	
Corfieldy Quarry	NJ	67310	01147	5.93	10.34	23.7	4.932171	3.742794182	Quarry Face in the main flooded quarry
				6.44	8.06	26.12	4.553118	3.181526553	
				6.16	9.24	26.33	4.850442	3.54334237	
Corfieldy Quarry	NJ	67317	01171	4.01	4.41	16.1	2.664144	-	Weathered naturally exposed face
				4.22	3.23	18.24	2.525175	-	
Corfieldy Quarry	NJ	67101	00952	5.28	8.83	24.6	4.538457	-	Friable pebble quarry, granite pale as it seems feldspar is preferentially eroded
				5.28	8.68	22.35	4.341222	-	
Blairhead	NJ	66070	01896	5.69	4.19	19.68	3.016602	-	Friable pebble

Farm				5.68	2.91	22.25	2.860839	-	quarry, microgranite
				5.6	4.08	20.57	3.041766	-	
Blairhead Farm	NJ	1672	66292	5.43	2.01	17.06	2.237166	-	Quarry, lots of vegetation cover
				5.33	1.41	14.35	1.880334	-	
Crathes Castle	NO	73230	96711	4.05	0.54	12.06	1.370763	-	
				3.48	2.1	10.87	1.641924	-	
Crathes Castle	NO	73149	96739	3.56	2.94	13.71	2.068848	-	
				3.77	3.11	16.66	2.340306	-	
Crathes Castle	NO	73066	96721	3.68	3.86	15.05	2.415204	-	
				3.63	3.12	19.79	2.549421	-	
				3.78	4.4	16.68	2.680506	-	
Hill of Fare	NJ	68624	02710	3.53	6.59	12.71	2.951748	-	Underestimated due to topography
				3.52	4.42	15.52	2.579742	-	
				3.84	3.24	14.75	2.246886	-	
				4.01	4.96	15.09	2.737287	-	
Hill of Fare	NJ	69107	03113	3.66	5.52	16.97	2.982852	-	Underestimated, small outcrop in road.
				3.81	5.9	18.6	3.210975	-	
Hill of Fare	NJ	70262	03299	4.32	5.57	26.94	3.758211	-	Reading from a boulder
				4.23	4.72	25.53	3.428109	-	
Hill of Fare	NJ	70976	03695	4.4	7.02	27.97	4.217832	-	
				3.99	8.05	24.95	4.23684	-	
				4.4	7.07	29.29	4.323591	-	
Hill of Fare	NJ	72257	02588	3.78	9.03	25.55	4.515777	-	On top of Meikle Tap. Poor exposure with bedrock just poking through path
				3.69	8.47	25.76	4.37535	-	
Hill of Fare	NJ	72270	02575	4.39	8.73	26.82	4.584006	-	Meikle Tap orthogonal joint set of N-S and W-E
				4.1	11.19	24.59	5.044329	-	
				4.22	7.36	30.24	4.449222	-	
				4.35	8.64	23.89	4.350969	-	



Hill of Fare	NJ	72214	02621	5.6	9.71	29.44	5.138937	-	N-S and w-E trending joints
				5.07	9.54	26.54	4.840749	-	
				5.22	11.01	30.25	5.500359	-	
				5.42	11.54	26.93	5.425002	-	
Hill of Fare	NJ	71543	02979	3.51	5.36	22.29	3.300237	-	Underestimated due to topography
				4.27	6.5	26.65	3.976695	-	
				4.31	6.14	22.75	3.612411	-	
Hill of Fare	NJ	67894	01716	3.78	7.33	22.56	3.860649	-	Underestimated due to topography
				3.83	5.85	26.17	3.731184	-	
				3.89	6.64	22.7	3.700161	-	
Hill of Fare	NJ	69864	02769	4.52	5.32	18.28	3.103704	-	Microgranite, medium sized boulder underestimated <2pi
				4.63	4.44	17.44	2.824659	-	
Hill of Fare	NJ	69862	02772	4.54	6.39	16.64	3.270699	-	Microgranite, partial exposure poking through the 4x4 track
				4.54	5.72	17.34	3.144366	-	
				4.29	6.62	18.02	3.404187	-	