



Lopes, R. D. et al. (2013) Methodology of a reevaluation of cardiovascular outcomes in the RECORD trial: study design and conduct. *American Heart Journal*, 166(2), 208-216.e28.

Copyright © 2013 The Authors.

This work is made available under the Creative Commons Attribution-NonCommercial-NoDerivs 3.0 Unported License (CC BY-NC-ND 3.0).

Version: Published

<http://eprints.gla.ac.uk/103220/>

Deposited on: 9 June 2015

Enlighten – Research publications by members of the University of Glasgow <http://eprints.gla.ac.uk>

Methodology of a reevaluation of cardiovascular outcomes in the RECORD trial: Study design and conduct

Renato D. Lopes, MD, PhD,^a Sheila Dickerson, RN,^a Gail Hafley, MS,^a Shana Burns, BS,^a Sandra Tourt-Uhlig, RN,^a Jennifer White, MS,^a L. Kristin Newby, MD,^a Michel Komajda, MD,^b John McMurray, MD,^c Robert Bigelow, PhD,^a Philip D. Home, DM,^d and Kenneth W. Mahaffey, MD^a *Durham, NC; Paris, France; and Glasgow, and Newcastle upon Tyne, United Kingdom*

Background In 2010, after regulatory review of rosiglitazone licensing, the US Food and Drug Administration (FDA) requested a reevaluation of cardiovascular end points in the RECORD trial.

Methods Automated screening of the original clinical trial database and manual case report form review were performed to identify all potential cardiovascular and noncardiovascular deaths, and nonfatal myocardial infarction (MI) and stroke events. Search techniques were used to find participants lost to follow-up, and sites were queried for additional source documents. Suspected events underwent blinded adjudication using both original RECORD end point definitions and new FDA end point definitions, before analysis by the Duke Clinical Research Institute.

Results The reevaluation effort included an additional 328 person-years of follow-up. Automated screening identified 396 suspected deaths, 2,052 suspected MIs, and 468 suspected strokes. Manual review of documents by Duke Clinical Research Institute clinical events classification (CEC) coordinators identified an additional 31 suspected deaths, 49 suspected MIs, and 28 suspected strokes. There were 127 CEC queries issued requesting additional information on suspected deaths; 43 were closed with no site response, 61 were closed with a response that no additional data were available, and additional data were received for 23. Seventy CEC queries were issued requesting additional information for suspected MI and stroke events; 31 were closed with no site response, 20 were closed with a response that no additional data were available, and 19 resulted in additional data.

Conclusions Comprehensive procedures were used for rigorous event reascertainment and readjudication in a previously completed open-label, global clinical trial. These procedures used in this unique situation were consistent with other common approaches in the field, were enhanced to address the FDA concerns about the original RECORD trial results, and could be considered by clinical trialists designing event readjudication protocols for drug development programs that have been completed. (*Am Heart J* 2013;166:208-216.e28.)

Identification of suspected clinical end points using prespecified event definitions is critical to event adjudication efforts in multinational clinical trials.¹ The

RECORD trial was a randomized, open-label trial comparing rosiglitazone-containing combination therapy for type 2 diabetes with the dual oral combination of metformin and a sulfonylurea. The trial (ClinicalTrials.gov, NCT00379769) was conducted from 2001 to 2008.²

The results of the RECORD trial, together with other data, were reviewed and discussed in July 2010 by an Advisory Committee of the US Food and Drug Administration (FDA). After the review, the FDA required the sponsor of the RECORD trial, GlaxoSmithKline (GSK), to commission a comprehensive, reevaluation of the cause of deaths and of 2 nonfatal events: myocardial infarction (MI) and stroke. The Duke Clinical Research Institute (DCRI) was selected to conduct the review. Results of the reevaluation are presented separately.³ This article reports the methods that were developed to perform the reevaluation effort. The key objectives of this effort were to (1) systematically identify

From the ^aDuke Clinical Research Institute, Duke University Medical Center, Durham, NC, ^bUniversité Pierre-et-Marie-Curie and Pitié-Salpêtrière Hospital, Paris, France, ^cUniversity of Glasgow, Glasgow, United Kingdom, and ^dNewcastle University, Newcastle upon Tyne, United Kingdom.

Submitted May 1, 2013; accepted May 8, 2013.

Reprint requests: Renato D. Lopes, MD, Box 3850, 2400 Pratt St, Room 0311 Terrace Level, Durham, NC 27705.

E-mail: renato.lopes@duke.edu

0002-8703 © 2013, The Authors. Published by Mosby, Inc.

Open access under [CC BY-NC-ND](https://creativecommons.org/licenses/by-nc-nd/4.0/) license.

<http://dx.doi.org/10.1016/j.ahj.2013.05.005>

all deaths, suspected MIs, and strokes blinded to treatment; (2) derive end-of-follow-up dates; (3) adjudicate all suspected events by original RECORD definitions and by contemporary definitions under development by the FDA (Standardized Data Collection for Cardiovascular Trials Initiative); and (4) report event rates and time-to-event analyses by treatment group.

Methods

Planning

The DCRI coordinated all clinical events classification (CEC) operations for the RECORD reevaluation protocol in collaboration with the sponsor. In the planning phase, leadership from the sponsor, the FDA, and the DCRI discussed critical issues to design the reevaluation effort, particularly the event identification (“triggering”) strategy, the need for collection of additional source documents, and additional ascertainment of lost-to-follow-up patients. The original RECORD principal investigator and trial CEC chairman reviewed and commented on the draft protocol for the reevaluation effort.

The DCRI CEC team created and maintained the CEC charter for RECORD reevaluation, as well as the adjudication pages used to capture key data required for the efficient and accurate adjudication and final analysis of end point events. The DCRI CEC charter (online Appendix A) describes the operations followed for identification of suspected events, collection of data and source documents, DCRI reevaluation, and quality control. It also details the organization, roles, and activities of the DCRI CEC group, including the physicians who formed the DCRI CEC Committee.

The DCRI CEC group systematically identified, adjudicated, and classified the following suspected events using prespecified criteria: cause of death, MI, and stroke.

Duke Clinical Research Institute CEC Committee members

The DCRI CEC Committee members were physicians who provided clinical expertise in development of the CEC processes and CEC adjudication forms and participated in adjudication of suspected end points. No sponsor representatives or members of the original RECORD CEC committee served on the DCRI CEC Committee. Members included faculty-level endocrinologists, cardiologists, neurologists, and other physicians with relevant clinical expertise, involvement in clinical research, and prior CEC experience.

All CEC Committee physicians were trained regarding the RECORD reevaluation protocol and event definitions before starting event adjudication. Documented training comprised an overview of the protocol, trial timelines, specific definitions and supporting documentation for each event type, adjudication form instructions, and adjudication timeline expectations.

Identification of suspected events

A comprehensive process to “trigger” all potential death, MI, and stroke events included both automated and manual trigger procedures (Figure 1). This process was designed to systematically identify events from investigator-identified events, case report forms (CRFs), and adverse event (AE), and serious AE (SAE) reporting; to try to mitigate any potential reporting bias

(RECORD was open label); and to ensure that all potential events were identified and reviewed. Vital status in those participants lost to follow-up was ascertained, as detailed below.

Automated trigger procedures. The automated procedures included a computer program (trigger program) that was applied to the original RECORD CRF clinical database, looking for evidence that an event may have occurred. The following CRFs and CRF subforms were screened by the automated trigger program: Adverse Event Form, Serious Adverse Event Form, Death Form, Study Continuation/Withdrawal Form, Tracking Form for Completely Withdrawn Patients, Survival Status Form, Third Party Survival Data Form, and Cardiovascular Procedure/Amputation End Point Form. All Medical Dictionary for Regulatory Activities-coded AE and SAE terms in the clinical database were electronically screened to identify potential cardiovascular end points. Determination of which terms would be used to identify cardiovascular end points was made by DCRI clinical and safety experts. Details of the automated procedures and trigger specifications are contained within the RECORD reevaluation CEC trigger specifications (online Appendix B). Each potential event was tracked throughout the process using a unique identifier.

Manual trigger procedures. The DCRI CEC coordinators manually reviewed all paper documents separately from the output from the automated trigger program. These coordinators had extensive experience in cardiology event reporting and in CEC methodologies. A quality control process was implemented for the manual review (see below).

Source documents and further data collection. Participant identifiers, treatment assignment, and other glucose-lowering agent use were redacted from all data sent to the DCRI CEC, a task performed a priori by GSK. Blinding was checked by DCRI CEC coordinators and assistants before event dossiers were sent to CEC physicians, further redaction being performed if necessary.

The DCRI also accessed the source documents used by the original RECORD CEC (Table I). For newly identified events, source documents required are listed in Table II. Source documents were requested from investigator sites for both previously adjudicated and new end points, including the former missing documents. When needed by the DCRI CEC, additional information was requested (up to 2 attempts) from sites and locally redacted before submission to the CEC. All new data were identified as such to allow evaluation both with the original and the original plus new data, and thus, after completion of readjudication and database lock, comparisons between original and new adjudication of events. Documents not in English were translated by an outside vendor.

Ascertainment of vital status. Using the RECORD study data supplied by GSK, DCRI identified patients whose vital status at the end of the study was not known or documented. MediciGlobal (King of Prussia, PA), was contracted to search globally for vital status information for these patients. Data were updated for newly discovered deaths, known deaths with new information, and new “last-known-alive” dates.

Database transfers and conversion for end points reevaluation

Electronic data containing the raw CRF data were transferred as SAS data sets in prespecified format from GSK to the DCRI in 3

Figure 1

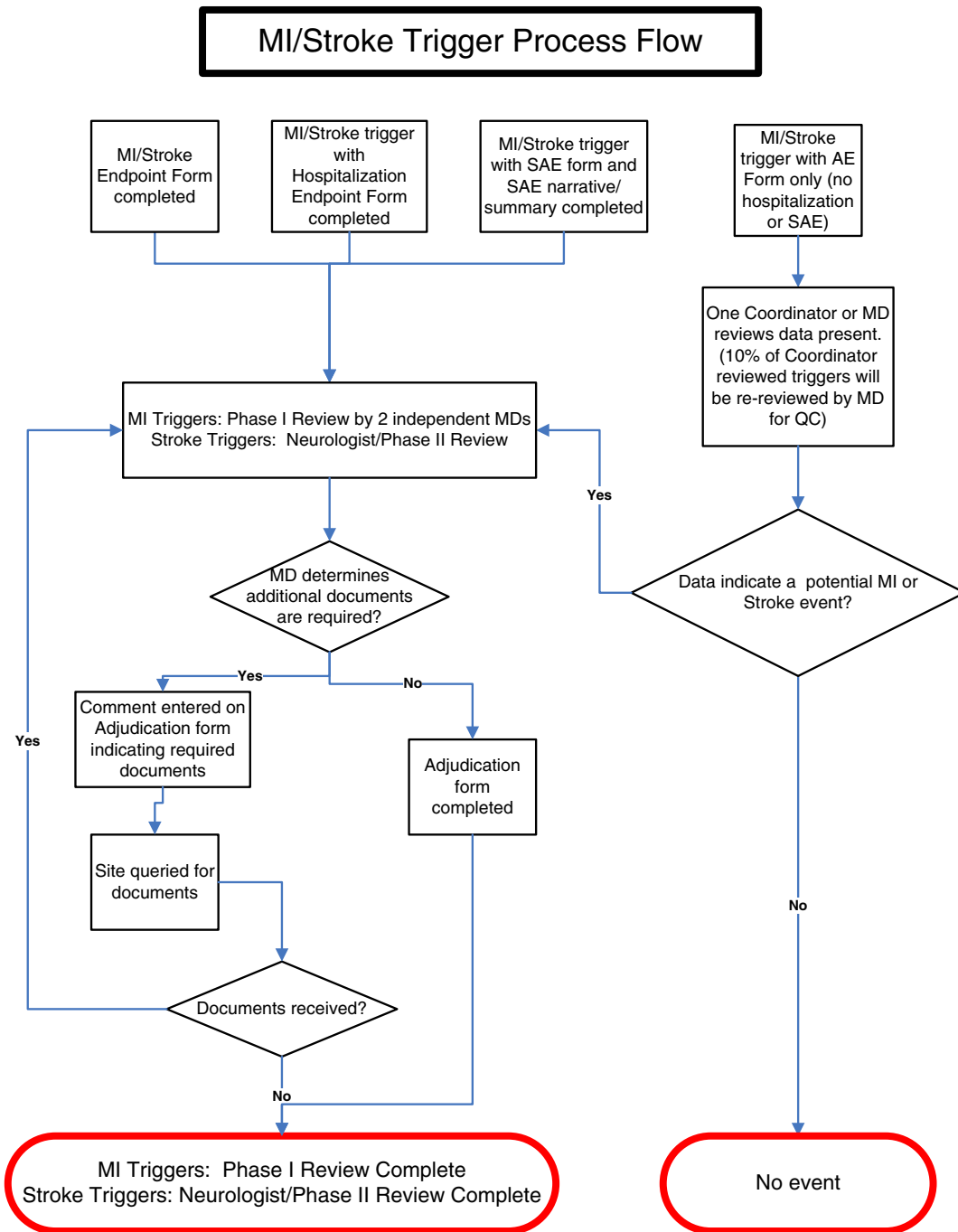

Trigger process. MD, CEC committee physician; QC, quality control.

phases. Phase 1 transfer included the raw CRF data sets needed to provide electronic identification of events for referral to the DCRI CEC. DCRI programmers checked and, where necessary, requested further redaction and data retransfer. Phase 2 transfer occurred after completion of DCRI electronic identification of

potential events; this transfer included treatment start and stop dates (blinded) and a data set containing the identification numbers for deaths, as originally reported. Phase 3 transfer included treatment information (unblinded); these data were kept firewalled from the clinical team until all DCRI

Table I. Original RECORD CEC source documents

Event	Document
Death (in hospital)	Death summary or investigator narrative
Death (out of hospital)	Autopsy report
	Investigator narrative
Hospitalization for acute MI	Autopsy report
	Police report/family records/available documentation describing circumstances of death
	Discharge summary or investigator narrative with ECG description and cardiac biomarker results
	ECG (if not in discharge summary)
	Cardiac biomarker results (if not in discharge summary)
Hospitalization for stroke	Discharge summary or investigator narrative with neurologist investigations neurologic report (if not in discharge summary)

Abbreviation: ECG, Electrocardiogram.

adjudications were completed. The data were placed in a secure folder on the DCRI server, and access was granted only to the unblinded statistical team members responsible for producing the report of readjudicated events.

Event adjudication

The DCRI CEC process is summarized in [Figure 2](#). The DCRI CEC physicians adjudicated each suspected event identified by the automated or manual trigger procedures described above using prespecified end point criteria based on the preponderance of the evidence, clinical knowledge, and experience. All events were reviewed using the original RECORD end point definitions themselves, reflecting European Society of Cardiology recommendations, and—by request of the FDA—were also reviewed using new FDA end point definitions that resulted from the Standardized Data Collection for Cardiovascular Trials Initiative.^{4,5} [Online Appendix C](#) displays the original RECORD end point definitions, and [online Appendix D](#) provides the new FDA definitions. The key differences between the original RECORD end point definitions and the new FDA definitions are shown in [Table III](#).

Potential events triggered from an AE term only, with no hospitalization or source documentation present, were reviewed by a single clinician (DCRI CEC coordinator or physician) to confirm whether there was a potential event. If that was the case, the event dossier and data were forwarded for review by physicians, including possible stroke events by a neurologist. Events were allocated to 2 physicians acting independently, and for MI, a separate pair of physicians were used for original and FDA definitions. If one reviewer requested and received additional information, it was also given to the other reviewer.

Where the 2 reviewers agreed in adjudication of the suspected event, the end point classification was deemed complete. Otherwise, the event was referred to an adjudication committee. At least 3 faculty physicians were required for this, with a decision made by consensus. The basis of the decision was documented. If further information was requested, the event was reviewed at a further meeting.

Table II. RECORD CEC reevaluation source documents for new events

Event	Document
Death	Death summary
	Investigator summary
	Autopsy report
MI	Discharge summary
	Baseline and 2 event ECGs
	Cardiac biomarker results
Stroke	Discharge summary or investigator narrative
	Imaging reports (CT/CTA, MRI/MRA)
	Neurology consult notes

Abbreviations: ECG, Electrocardiogram; CT, computed tomography; CTA, computed tomography angiography; MRI, magnetic resonance imaging; MRA, magnetic resonance angiography.

For suspected strokes, phase 1 review required 2 neurologists or, alternatively, review by the CEC committee, which then had to include a neurologist ([Figure 2](#)).

Quality control of the evaluation process

A random sample of adjudicated events was re-reviewed by a committee of at least 3 DCRI CEC faculty physicians who were blind to the initial decision. The quality control plan was based on a 5% random sample of adjudicated events (but greater than the square root of the number of events plus 1) generated by the DCRI CEC statistician. The sample was weighted toward the earlier part of the adjudication process for mortality events.

A “major” discrepancy was declared when there was disagreement on whether a defined event had occurred. A “minor” discrepancy involved disagreement on the date, time, type, or evidence. Major discrepancies were allowed to update the adjudication database but only after further committee review and discussion with the CEC principal investigator. Events with a minor discrepancy were not re-reviewed, and the results remained unchanged in the database.

Quality control of the manual trigger program

A random sample of the documents that were screened during the manual trigger procedures were rescreened by a physician using the same documents originally screened by the coordinators. The sample size was 5% of the participants screened and not triggered for an end point event, plus 5% of all other manual triggers.

Statistical analysis

Details of the statistical analysis plan (SAP) are described in the [online Appendices E and F](#). In brief, the first phase of the event reevaluation process entailed adjudication of all-cause and cardiovascular (or unknown cause) mortality, and comparative analyses were completed. In the second phase, MIs and strokes were adjudicated, and analyses of these and major adverse cardiac events (earliest of MI, stroke, or cardiovascular death) were conducted. All analyses were performed for both original RECORD CEC and new FDA definitions.

For each end point, the hazard ratio (HR; rosiglitazone compared with metformin/sulfonylurea) and 95% confidence intervals were calculated using Cox proportional hazard

Figure 2

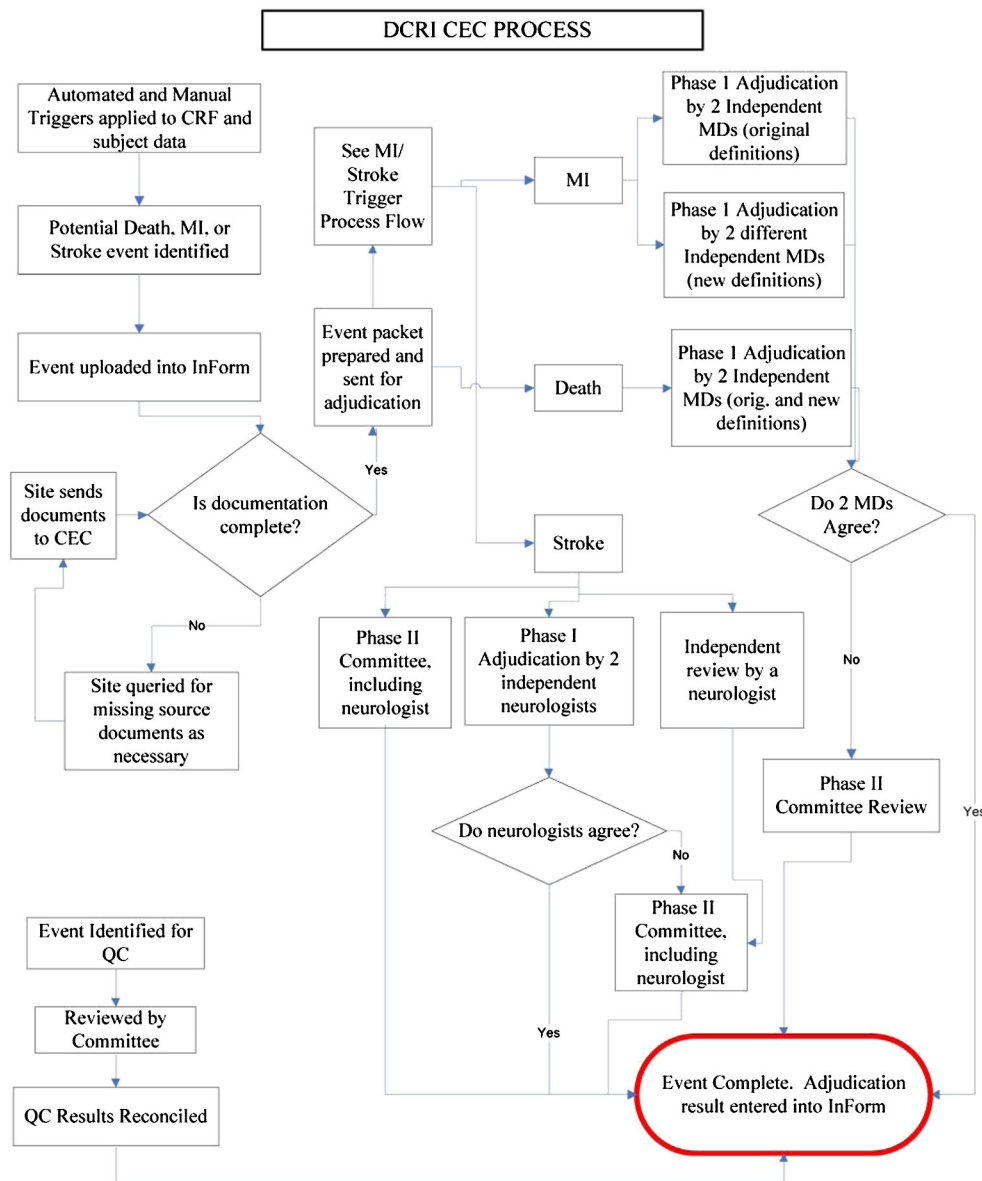

Clinical events classification process flow. MD, CEC Committee physician; QC, quality control.

modeling, stratified by background therapy (metformin or sulfonylurea). The HRs (95% CIs) were also calculated for each background therapy group, and a test for interaction was conducted at the $P < .10$ level. This statistical approach was similar to that used in the original RECORD study. Event rates (per 100 years) were reported for each end point.

Mortality and major adverse cardiac events

A DCRI statistician (G.H.) participated in the development of the event trigger rules, adjudication forms, and query rules; drafted the SAP; created the analysis data set; wrote the reporting specifications; and oversaw the statistical program-

ming and quality control. She remained blinded to treatment allocation throughout phases 1 and 2 (see above). A DCRI faculty/reviewing statistician (R.B.) who provided consultation on these statistical activities also remained so blinded. These personnel controlled all access to treatment assignments or use of other glucose-lowering medications.

Two DCRI statisticians were also unblinded to review the mortality event reevaluation results once completed.

Blinding

Formal procedures were identified to ensure blinding of the randomly assigned treatment group until knowledge of the

Table III. Key differences between original RECORD and new FDA end point definitions

Event	Original RECORD end point definitions	New FDA end point definitions
Death	CV death will include death after heart failure, death after acute MI, sudden death, and death due to acute vascular events. Death due to acute vascular events is defined as death due to aortic dissection, aortic aneurysm, pulmonary embolism, stroke, or any other vascular cause. Deaths with an unknown cause will be counted as CV death for the primary end point analysis.	CV death includes death resulting from an acute MI, sudden cardiac death, death due to heart failure, death due to stroke, and death due to other CV causes. Death due to other CV causes refers to a CV death not included in above categories (eg, dysrhythmia, pulmonary embolism, CV intervention, aortic aneurysm rupture, or peripheral arterial disease). Mortal complications from cardiac surgery or nonsurgical revascularization will be classified as CV death.
MI	Hospitalization plus troponin I or T > ULN or CK/CK-MB $\geq 2 \times$ ULN, plus one of the following: • Typical symptoms of ischemia • New pathological ECG findings as defined in 2000 ⁵	Spontaneous MI: cardiac biomarkers > ULN, plus ischemia presentation or ECG evidence of ischemia or new pathological Q waves or imaging evidence of new loss of viable myocardium or new regional wall motion abnormality or autopsy evidence of acute MI Peri-PCI MI: troponin or CK-MB > 3 \times ULN within 48 h post-PCI or new Q waves post-PCI or autopsy evidence of MI post-PCI Peri-CABG MI: troponin or CK-MB > 5 \times ULN, plus new Q waves or new LBBB or angio evidence of new graft or native artery occlusion or operating room complication resulting in loss of myocardium or imaging evidence of new loss of viable myocardium Peri-CABG MI: autopsy evidence of acute MI post-CABG Silent MI: no evidence of acute MI, plus new Q waves or imaging evidence of a region of loss of viable myocardium that is thinned and fails to contract or autopsy evidence of a healed or healing MI Acute episode of neurologic dysfunction caused by focal or global brain, spinal cord, or retinal vascular injury Ischemic: acute episode of focal cerebral, spinal, or retinal dysfunction caused by an infarction of the central nervous system tissue Hemorrhagic: acute episode of focal or global cerebral or spinal dysfunction caused by a nontraumatic intraparenchymal, intraventricular, or subarachnoid hemorrhage
Stroke	Hospitalization plus Rapidly developed clinical signs of focal or global disturbance of cerebral function lasting more than 24 h (unless interrupted by thrombolysis, surgery, or death), with no apparent cause other than a vascular origin Strokes resulting from blood diseases, brain tumors, brain metastasis, or trauma should be excluded.	

Abbreviations: CV, Cardiovascular; ULN, upper limit of normal; CK, creatine kinase; ECG, electrocardiogram; PCI, percutaneous coronary intervention; CABG, coronary artery bypass graft; LBBB, left bundle-branch block.

treatment assignment was required or the reevaluation effort was completed. The principal investigator for the reevaluation (K.W.M.) remained blinded until statistical analyses were complete.

The DCRI faculty lead for the first phase reevaluation of mortality (L.K.N.) was unblinded to review these reevaluation results once complete. The mortality report was reviewed by 9 GSK personnel who were firewalled from the reevaluation process to check the accuracy of text citing the original RECORD trial or describing steps taken by GSK to obtain additional follow-up information. This group was also responsible for fulfilling the study sponsor's regulatory submission requirements and informed the GSK Corporate Executive Team about the completion of the first phase and apprised them of the results.

The DCRI faculty lead for the second phase reevaluation of major adverse cardiac events (R.D.L.) was unblinded after the database lock to review the results of reevaluation of major adverse cardiac events, MI, and stroke and to help prepare the study report of the second phase.

Role of the funding source

The role of the sponsor (GSK, King of Prussia, PA) in the conduct of the study has been published previously.² Funding for the reascertainment and reevaluation was provided to DCRI. The sponsor and members of the RECORD Steering Committee

reviewed and commented on the protocol and procedures of reevaluation before any reascertainment activity but did not have any further role until reevaluation was finalized. It was planned that the original RECORD leadership and DCRI leadership would review the results of the reevaluation effort and review discrepant adjudications as a learning activity. Both DCRI and the RECORD Steering Committee representatives made the decision to publish the findings and have written the manuscript jointly. The manuscript was reviewed by sponsor representatives for accuracy.

Results

Myocardial infarction/stroke event triggers

A total of 2,597 MI/stroke triggers were identified, 2,101 MIs and 496 strokes. The automatic trigger program identified 2,052 MIs and 468 strokes, and manual document review identified 49 MIs and 28 strokes. Of the 2,597 events triggered, there were 4 for which there was no evidence in the medical records that an event occurred, whereas 697 duplicate triggers for another event were set to linked status. (ie, if more than 1 trigger fired for the same event, only 1 trigger was adjudicated, and the other triggers were listed at the bottom of the CEC adjudication forms as "supplemental

trigger repeats"). There were, therefore, only 1,896 unique events; these 1,896 MI/stroke event triggers were then identified for adjudication. Thus, there were no duplicate events, but just duplicated triggers for other events, which were evaluated and resolved by the DCRI group before adjudication.

Myocardial infarction/stroke queries

For the suspected MI and stroke events, 70 CEC queries requesting additional information from the site investigators or coordinators were issued with the following results: 31 queries were closed with no response from the site, 20 queries were closed with a response that no additional data were available, and 19 queries were closed with additional data being received. Of these 19, 2 resulted in changed MI adjudication results (yes/no), one in each direction.

Death event triggers

A total of 427 death event triggers were identified. The automatic trigger program identified 396 deaths, and 31 deaths were identified manually. Of the total, 100 triggers were not adjudicated because there was no evidence on checking the medical record that a death had occurred.

Death queries

A total of 127 CEC queries were issued for additional information to follow up on death events classified as "unknown" and "insufficient information." The queries for these 127 patients resulted in 43 with no response from the site, 61 with a response that no additional data were available, and 23 closed with additional data received from the site. Of these 23 queries, 16 deaths were re-reviewed with no change to the adjudication result, and 7 events were re-reviewed with a change to the adjudication result from unknown to a known cause of death.

Quality control findings

A medical review of 100 randomly selected stroke and MI events was performed blind to treatment assignment and original DCRI CEC adjudication outcome. In 93 events, there was no discrepancy in the determination. There was 1 major discrepancy (change of event classification), 2 discrepancies involving Q-wave classification, and 4 other discrepancies involving event date/time. A medical review of 25 randomly selected death events were also performed as part of the quality control process. There were 2 major discrepancies on cause of death. Both of them occurred in the first 10 quality control death cases and were originally called sudden cardiac deaths; after the quality control review, they were changed to unknown cause in the database. There were no major discrepancies in the subsequent 15 quality control death cases.

Discussion

Diabetes is an epidemic disease that is expected to affect around 450 million people by 2030, with a substantial increase in incidence in developing countries.⁶⁻⁸ The direct health care costs of diabetes range from 2.5% to 15% of annual health care budgets.⁹ Although intensive glucose control has been associated with lower rates of MI, it also has been associated with higher mortality rates, including cardiovascular mortality.^{10,11} Conventional therapies for diabetes have not been tested for cardiovascular outcomes in long-term clinical trials. In this context, the RECORD study, planned in 2000 and begun in 2001, and later consistent with the FDA's December 2008 recommendation for study of new treatments for type 2 diabetes,² evaluated the cardiovascular safety of rosiglitazone.

The available data on risk of myocardial ischemia among patients using rosiglitazone are inconclusive. A meta-analysis of 42 short-term clinical studies (most of which compared rosiglitazone with placebo), including 14,237 patients with a mean duration follow-up of 6 months, suggested an association between rosiglitazone use and an increased risk of myocardial ischemic events.¹² Other studies, including the RECORD trial, comparing rosiglitazone with other oral diabetes medications or placebo (total patients around 14,000, with a mean follow-up of 41 months) have not shown the same risk.^{2,13,14}

Several examples of treatment that improve surrogate end points, such as decreasing glycated hemoglobin in patients with diabetes or increasing hemoglobin value in patients with cancer or renal disease, have subsequently been found to cause an increase in important clinical events, including mortality.^{5,15-19} Indeed, the RECORD trial confirmed the increased rate of distal fractures in women identified by ADOPT in 2008²⁰ and quantified the rate of increase of hospitalizations for heart failure. However, the primary end point was cardiovascular safety of rosiglitazone, defined as all cardiovascular hospitalizations. Participants were followed up for 5.5 years, on average, in a comparative (vs metformin or sulfonylurea) design. There were several secondary end points including a major cardiovascular event composite (cardiovascular death, MI, or stroke). All cardiovascular end points were determined by a team of cardiologists/stroke physician/diabetologists blinded to treatment assignment. The study reported no difference in the occurrence of the primary end point in the rosiglitazone group compared with combined use of metformin and a sulfonylurea.²

The RECORD trial was designed as an open-label study in which the clinical events were adjudicated in a blinded fashion. Despite that, concerns were raised by some about ascertainment bias of clinical events in the study, as well as improper processing of some end points, and absence of systematic identification of potential cardiovascular clinical events remote from the investigator site.²¹

Therefore, the DCRI RECORD CEC reevaluation was undertaken to attempt to address the regulatory, research, and clinical communities' concerns about the efficacy and safety of rosiglitazone in people with type 2 diabetes. This effort, which had the collaboration of the original RECORD trial leadership, sponsor (GSK), the FDA, and the DCRI, included an intense, and comprehensive process to identify all possible events that might have occurred in the original RECORD trial. The DCRI CEC group used predefined criteria to review all suspected incidences of deaths (cardiovascular and noncardiovascular), MI, or stroke and to judge whether a death, MI, or stroke had actually occurred. For patients deemed to have died or had an MI or stroke, the CEC identified the date of the event. The end of follow-up for patients who did not experience cardiovascular death, MI, or stroke was considered to be the last date at which vital signs were recorded on the CRF.

Clinical events classification efforts are becoming more common as a result of interactions between the FDA and pharmaceutical companies. For the RECORD reevaluation, extensive efforts were made to obtain additional source documentation for selected events as well as vital status for patients who did not complete the study follow-up. These efforts were challenged by multiple factors including closure of some research sites, lack of current institutional review board approval, national regulations preventing additional follow-up, unavailability of principal investigators and coordinators, and the long elapsed time since the initial trial had completed. Thus, many queries that were sent to the sites could not be answered, nor could new information be obtained from the sites to allow for the addition of new events to the analysis. It is uncertain whether additional source document collection would have resulted in additional events being identified. Researchers may consider this information when planning retrospective efforts to collect additional clinical data in previously completed trials or drug development programs.

The analysis of the primary end point using both the original RECORD end point definitions and the new draft FDA end point definitions may add relevant information to rosiglitazone's profile, allow interpretation of the RECORD trial with a contemporary set of clinical end point definitions, and provide insights about the value of the revised definitions compared with historical standards. There is consensus about the need for standardized definitions to allow comparison of event rates across trials and over time, but the specific criteria in the definitions are often still debated.

Conclusions

A comprehensive, systematic, and blinded, program was designed to reevaluate event ascertainment and adjudication in the RECORD trial at the request of the FDA. Procedures included rigorous blinding of randomized treatment assign-

ment, collection of additional information about patients previously lost to follow-up, and systematic identification of all deaths and suspected MI and stroke events using the raw data set. These procedures used in this unique situation were consistent with other common approaches in the field, were enhanced to address the FDA concerns about the original RECORD trial results, and could be considered by clinical trialists designing event readjudication protocols for drug development programs that have been completed.

Acknowledgements

GlaxoSmithKline (King of Prussia, PA) funded the study, and the analysis was performed at the DCRI (Durham, NC). We thank Peter Hoffmann for his editorial assistance.

Disclosures

Dr Lopes has received a research grant from Bristol-Myers Squibb and consulting fees from Pfizer and Boehringer Ingelheim. Dr Newby has received research grants from GSK, Merck, and Roche, as well as consultant fees from Amgen and GSK; a full list of financial disclosures can be seen at www.dcri.org. Dr Komajda has received fees and research grants, or both from Groupe Servier; consultancy fees from Nile Therapeutics and Bristol-Myers Squibb; payment for service on speakers' bureau from Sanofi-Aventis, Menarini, Bristol-Myers Squibb, Merck, and AstraZeneca; and funding for research, educational, and/or advisory activities from GSK. Dr McMurray's travel and accommodation for RECORD Steering Committee meetings were paid by GSK, and his employer was paid by GSK for his time spent as a Steering Committee member. Dr Bigelow owns stock in Merck, Sanofi, Pfizer, and Johnson & Johnson. Dr Home (or institutions with which he is associated) has received funding for research, advisory, and teaching activities from AstraZeneca/BMS Collaboration, Boehringer Ingelheim, GSK, Merck, Eli Lilly, Janssen/Johnson & Johnson, Merck Serono, Novartis, Novo Nordisk, Groupe Servier, Pfizer, Roche Pharma, Roche Diagnostics, Sanofi, and Takeda. Dr Mahaffey has received research grants from Amylin and Bristol-Myers Squibb and research grants and consultant fees from GSK, Johnson & Johnson, Merck, and Eli Lilly; a full list of financial disclosures can be seen at www.dcri.org. The other authors declare that they have no conflicts of interest.

References

1. Mahaffey KW, Roe MT, Dyke CK, et al. Misreporting of myocardial infarction end points: results of adjudication by a central clinical events committee in the PARAGON-B trial. Second Platelet IIb/IIIa Antagonist for the Reduction of Acute Coronary Syndrome Events in a Global Organization Network Trial. *Am Heart J* 2002;143:242-8.
2. Home PD, Pocock SJ, Beck-Nielsen H, et al. Rosiglitazone evaluated for cardiovascular outcomes in oral agent combination therapy for type 2 diabetes (RECORD): a multicentre, randomised, open-label trial. *Lancet* 2009;373:2125-35.

3. Mahaffey KW, Haffley G, Dickerson S, et al. Results of a reevaluation of cardiovascular outcomes in the RECORD trial. *Am Heart J* 2013; 166(2):240-9.
4. Hicks KA, Hung HMJ, Mahaffey KW, et al. Standardized definitions for end point events in cardiovascular trials. http://www.clinpage.com/images/uploads/endpoint-defs_11-16-2010.pdf.
5. Myocardial infarction redefined—a consensus document of The Joint European Society of Cardiology/American College of Cardiology Committee for the Redefinition of Myocardial Infarction. *Eur Heart J* 2000;21:1502-13.
6. Shaw JE, Sicree RA, Zimmet PZ. Global estimates of the prevalence of diabetes for 2010 and 2030. *Diabetes Res Clin Pract* 2010;87:4-14.
7. Wild S, Roglic G, Green A, et al. Global prevalence of diabetes: estimates for the year 2000 and projections for 2030. *Diabetes Care* 2004;27:1047-53.
8. Olshansky SJ, Passaro DJ, Hershow RC, et al. A potential decline in life expectancy in the United States in the 21st century. *N Engl J Med* 2005;352:1138-45.
9. Roger VL, Go AS, Lloyd-Jones DM, et al. Heart disease and stroke statistics—2011 update: a report from the American Heart Association. *Circulation* 2011;123:e18-e209.
10. Action to Control Cardiovascular Risk in Diabetes Study Group-Gerstein HC, Miller ME, et al. Effects of intensive glucose lowering in type 2 diabetes. *N Engl J Med* 2008;358:2545-9.
11. Ray KK, Seshasai SR, Wijesuriya S, et al. Effect of intensive control of glucose on cardiovascular outcomes and death in patients with diabetes mellitus: a meta-analysis of randomised controlled trials. *Lancet* 2009;373:1765-72.
12. Nissen SE, Wolski K. Effect of rosiglitazone on the risk of myocardial infarction and death from cardiovascular causes. *N Engl J Med* 2007;356:2457-71.
13. Kahn SE, Haffner SM, Heise MA, et al. Glycemic durability of rosiglitazone, metformin, or glyburide monotherapy. *N Engl J Med* 2006;355:2427-43.
14. Gerstein HC, Yusuf S, Bosch J, et al. Effect of rosiglitazone on the frequency of diabetes in patients with impaired glucose tolerance or impaired fasting glucose: a randomised controlled trial. *Lancet* 2006; 368:1096-105.
15. Wright JR, Ung YC, Julian JA, et al. Randomized, double-blind, placebo-controlled trial of erythropoietin in non-small-cell lung cancer with disease-related anemia. *J Clin Oncol* 2007;25: 1027-32.
16. Henke M, Laszig R, Rube C, et al. Erythropoietin to treat head and neck cancer patients with anaemia undergoing radiotherapy: randomised, double-blind, placebo-controlled trial. *Lancet* 2003; 362:1255-60.
17. Leyland-Jones B. BEST Investigators and Study Group. Breast cancer trial with erythropoietin terminated unexpectedly. *Lancet Oncol* 2003;4:459-60.
18. Drüeke TB, Locatelli F, Clyne N, et al. Normalization of hemoglobin level in patients with chronic kidney disease and anemia. *N Engl J Med* 2006;355:2071-84.
19. Singh AK, Szczech L, Tang KL, et al. Correction of anemia with epoetin alfa in chronic kidney disease. *N Engl J Med* 2006;355: 2085-98.
20. Kahn SE, Zinman B, Lachin JM, et al, for the A Diabetes Outcome Progression Trial (ADOPT) study group. Rosiglitazone-associated fractures in type 2 diabetes: an analysis from a diabetes outcome progression trial (ADOPT). *Diabetes Care* 2008;31:845-51.
21. US Food and Drug Administration. FDA Briefing Document: Advisory Committee Meeting for NDA 21071 Avandia (rosiglitazone maleate) tablet: July 13 and 14, 2010. <http://www.fda.gov/downloads/AdvisoryCommittees/CommitteesMeetingMaterials/Drugs/EndocrinologicandMetabolicDrugsAdvisoryCommittee/UCM218493.pdf>.

Further reading

22. Woodcock, J. Regulatory action on rosiglitazone by the U.S. Food and Drug Administration. *N Engl J Med* 2010;363:1489-91.
23. Home PD, Pocock SJ, Beck-Nielsen H. Rosiglitazone evaluated for cardiovascular outcomes—an interim analysis. *N Engl J Med* 2007; 357:28-38.
24. Lindsey J, Ryan L. Tutorial in biostatistics methods for interval-censored data. *Stat Med* 1998;17:219-38.

Appendix A. Clinical Events Classification Charter

Readjudication Protocol AVD115170 “RECORD”

Rosiglitazone Evaluated for Cardiac Outcomes and Regulation of glycaemia in Diabetes

CEC Charter Effective Date: November 21, 2011

Abbreviations

Abbreviation	Definition
CABG	Coronary artery bypass graft
CDISC	Clinical Data Interchange Standards Consortium
CEC	Clinical events classification
CRF	Case report form
CT	Computed tomography (imaging)
CV	Cardiovascular
DCRI	Duke Clinical Research Institute
DM	Data management
ECG	Electrocardiogram
eCRF	Electronic case report form
EDC	Electronic data capture
FDA	Food and Drug Administration (United States)
GSK	GlaxoSmithKline
IRB	Institutional review board
MACE	Major adverse cardiac end points
MedDRA	Medical Dictionary for Regulatory Activities
MI	Myocardial infarction
MR	Magnetic resonance (imaging)
PCI	Percutaneous coronary intervention
RECORD	Rosiglitazone Evaluated for Cardiac Outcomes and Regulation of glycaemia in Diabetes
RSG	Rosiglitazone
SAE	Serious adverse event
SAP	Statistical analysis plan
TIA	Transient ischemic attack

1.0. Introduction

The Rosiglitazone Evaluated for Cardiac Outcomes and Regulation of glycaemia in Diabetes (RECORD) study was an open-label, randomized trial comparing rosiglitazone-containing combination therapy for type 2 diabetes with the most commonly used dual oral combination of metformin and a sulfonylurea. The study was conducted between 2001 and 2008 and published in 2009. The results of the RECORD study, together with other data, were reviewed and discussed at a July 13-14, 2010, joint meeting of the Endocrinologic and Metabolic Drugs Advisory Committee and the Drug Safety and Risk Management Advisory Committee. After this review, the Food and Drug Administration (FDA) required the sponsor of the RECORD study, GlaxoSmithKline (GSK), to commission a comprehensive independent readjudication, at the patient record level; to determine the cause of all deaths; and to adjudicate all suspected nonfatal myocardial infarction (MI) and all suspected nonfatal stroke end points of the study.

Representatives from the FDA and GSK have previously agreed that the readjudication effort will have 2

phases. The first phase will include the readjudication of all deaths, and those results will be analyzed and submitted to the FDA. The second phase will include the readjudication of the nonfatal MI and stroke events. The second phase will begin before completion of the first phase.

The Duke Clinical Research Institute (DCRI) has been asked by GSK to conduct the independent review and submit results to the FDA for comparison with those based on the adjudication outcomes from the original RECORD Clinical Endpoints Committee.

The primary objective of the readjudication is to address some of the critical FDA concerns about the RECORD trial that have been detailed. (FDA briefing document: <http://www.fda.gov/downloads/AdvisoryCommittees/CommitteesMeetingMaterials/Drugs/EndocrinologicandMetabolicDrugsAdvisoryCommittee/UCM218493.pdf>).²²

Key specific objectives include the following:

- Systematic identification of all deaths, all suspected MIs, and all suspected stroke events using all available data sources by reviewers who are blinded to patient treatment assignment
- Standard preparation of all events for adjudication without filtering of suspected events by persons who have knowledge (or potential knowledge) of patient treatment assignment
- Adjudication of all events using the original RECORD end point definitions and contemporary definitions under development by FDA through the Standardized Data Collection for Cardiovascular Trials Initiative

2.0. Role of the DCRI RECORD CEC group

The DCRI RECORD CEC group is responsible for the conduct of the CEC operations for the RECORD Readjudication Protocol, in collaboration with the sponsor, GSK. The DCRI CEC group creates and maintains the CEC Charter and will develop the event adjudication pages to capture key data required for the efficient and accurate adjudication and final analysis of the following suspected events:

- Cause of Death
- MI
- Stroke

3.0. RECORD CEC group organization

The RECORD CEC group will systematically identify, adjudicate, and classify suspected events while blinded to treatment assignment as well as all glucose-lowering agents. All subject personal identifiers, treatment assignment, and glucose-lowering agents will be redacted from the subject data, including all source documents. RECORD subject study numbers will not be redacted. The RECORD CEC group will develop trial-specific processes for the identification of suspected end point

events, the collection of additional required clinical data, and the adjudication of the suspected end point events using prespecified criteria.

3.1. Qualifications of the RECORD CEC Committee members. The RECORD CEC Committee members will consist of physicians who will provide clinical expertise in the development of the CEC processes and CEC adjudication and reporting forms, as well as in the adjudication of suspected end points. No GSK representatives will serve on the RECORD CEC Committee. Members may include endocrinologists, cardiologists, neurologists, or other physicians who have relevant clinical expertise and prior CEC experience.

Documentation of the required qualifications for the selected RECORD CEC physicians will be maintained at the DCRI in the form of current curricula vitae. Membership in the RECORD CEC Committee is for the duration of the study unless the member is deemed by the RECORD CEC chairperson in conjunction with the principal investigator to be unable to fulfill his/her responsibilities.

All RECORD CEC physicians will undergo training regarding the RECORD study before starting event adjudication. Training will be conducted by the RECORD CEC chairperson and/or RECORD CEC coordinators. Training material is produced and provided to the CEC physicians. This consists of an overview of the protocol, trial timelines, a detailed list and definition of each event to be adjudicated, supporting source documentation for each event, adjudication form completion instructions, and adjudication timeline expectations. Training documentation for each reviewer is maintained by the CEC.

3.2. DCRI RECORD CEC chairperson/director. One DCRI faculty member will be appointed as the RECORD CEC chairperson. The specific responsibilities of the CEC chairperson include the following:

- Preside over RECORD CEC readjudication conference calls and meetings or delegate to an appropriate designee from the CEC
- Ensure that ongoing QC reviews of readjudicated events are conducted and that the readjudication process is being conducted according to the RECORD CEC readjudication Charter and that end point criteria are being accurately applied
- Participate in the readjudication process
- Provide clinical support to the RECORD CEC coordinators and physicians

3.3. RECORD CEC physicians. The RECORD CEC physicians are responsible for the following:

- Adjudicate and classify events, with accurate and consistent application of the event criteria
- Participate in discussions related to event criteria and the application of the criteria
- Participate in adjudication conference calls and meetings

- Communicate schedule conflicts, including extended time away from office, to the RECORD CEC coordinator and chairperson
- Adherence to the event adjudication timeline

3.4. DCRI RECORD CEC operations director. The specific responsibilities of the RECORD CEC operations director include the following:

- Participate as needed in project conference calls and meetings
- Serve as a resource for the RECORD CEC coordinator
- Facilitate weekly project reviews with the RECORD CEC coordinator
- Provide ongoing support and feedback to the operations team

3.5. DCRI RECORD CEC project leader. The RECORD CEC project leader is responsible for the following:

- Develop the RECORD CEC project plan (in concert with team members) to include timelines, processes for clinical research studies, and milestones and recommend amendments to the RECORD CEC Charter as appropriate
- Develop and implement training and new processes in CEC to ensure that work flow is consistent with CEC SOPs
- Develops performance and process improvement strategies when appropriate

3.6. DCRI RECORD CEC coordinators. The RECORD CEC coordinators are responsible for the overall conduct of the CEC activities. Specific responsibilities include but are not limited to the following:

- Create and maintain the RECORD CEC Charter
- Develop efficient systems and work instructions for the RECORD CEC team
- Train and oversee the activities associated with adjudication work of the RECORD CEC team members
- Organize and facilitate the RECORD CEC Committee meetings
- Manage the workflow and ensure timelines are met
- Review all end point-specific source documents and CRF data to ensure that all available data have been supplied to the CEC physicians
- Review and process potential events triggered from AE term only
- Issue queries to the sites for additional source documents as necessary
- Work with RECORD Principal Investigator and RECORD CEC chairperson to develop electronic and manual trigger specifications to identify all potential events
- Ensure that all events identified from trigger specifications have been reviewed as appropriate

- Conduct Manual Trigger Procedures (described in Section 4.1.2) to ensure that all potential events are identified
- Work with RECORD Principal Investigator and RECORD CEC chairperson to develop adjudication forms

3.7. RECORD CEC clinical data assistant. Specific responsibilities include, but are not limited to, the following:

- Prepare and track event packets
- Data enter RECORD adjudication forms into RECORD CEC database (InForm)
- Generate reports
- Assist the CEC coordinator in the logistics and conduct of the CEC Committee adjudication meetings

3.8. RECORD CEC clinical trial assistant. Specific responsibilities include, but are not limited to, the following:

- Track source documents into the incoming document center
- Track subject folders into the CEC Tracking Database
- Assist CEC clinical data assistant to prepare and track event packets as necessary
- Assist the RECORD CEC coordinator in the collection of source documents

4.0. Operations

4.1. Identification of suspected events. A comprehensive process to identify or “trigger” all suspected end point events will be developed. Automated and manual procedures will be implemented. This process is designed to systematically identify the events from all data sources in which events may have been reported by the site investigators. This approach will be used to mitigate any potential reporting bias and to ensure that all potential events are identified and reviewed.

4.1.1. Automated trigger program. The automated procedures will include a computer program (trigger program) that includes, but is not limited to, the following:

- Screening of all Adverse Experience (AE) and Serious Adverse Experience (SAE) forms from the CRF data fields in the GSK RECORD data sets.
- Prespecified Medical Dictionary for Regulatory Activities coded terms will be used. The coded preferred terms were reviewed by clinical, CEC, and safety experts to identify terms that would potentially be indicative of an end point with a low threshold. A similar approach has been used in previous readjudication efforts.
- Death Form (Form D) when present in the database. Initial trigger specifications will be defined at the start of the program; however, they may be

modified during the course of the readjudication process, as needed. Any modifications will be documented and a rationale provided. The trigger specifications will be detailed in a separate document, titled RECORD Readjudication Trigger Specifications.

4.1.2. Manual trigger procedures. The RECORD CEC coordinators will perform a manual review of paper documents as well as reviewing the output from the automated trigger program. The CEC coordinators reviewing the paper documents have extensive experience in cardiology event reporting and CEC methodologies. A quality control (QC) process will be implemented for the manual review. Paper sources that the CEC coordinators will review to identify potential end points include, but are not limited to, the following:

- The unscheduled visit form (all visits) that inquires about hospitalizations (Hospitalization or Accident and Emergency Department Visit End Point Form) will be used to screen for potential end points. Cardiovascular and noncardiovascular reasons for admission will be assessed for review for potential MI and stroke end points. The following is a list of reasons that have been used in prior programs: heart failure, MI, acute coronary syndrome, unstable angina/cardiac chest pain, atrial fibrillation/flutter, other supraventricular, tachyarrhythmia, ventricular dysrhythmia, acute renal failure, acute or chronic renal failure, renal disease, other renal, stroke, transient ischemic attack, hypertension, hypotension, syncope/pre/syncope, peripheral arterial embolus, deep venous thrombosis, pulmonary embolus, vascular procedure, chronic obstructive pulmonary disease, and pneumonia.
- Source documents used as part of the original RECORD CEC adjudication process and any additional source documents collected as part of the readjudication activities (discharge summaries, progress notes, pertinent lab values, and physician narratives)
- Investigator verbatim terms
- All SAE and AE forms
- All cases that were sent to the original RECORD CEC; this would include end points that were adjudicated as non-end points and all cases that were later deleted by the investigator
- All Death End Point Forms
- All MI/Unstable Angina End Point Forms
- All Stroke/TIA End Point Forms
- All hospitalizations
- All Survival Status Forms
- All Documentation of Third Party Survival Data Forms
- All Tracking Forms for Completely Withdrawn Patients
- All Study Completion Forms
- All available 12-lead electrocardiogram (ECG) tracings for subjects who were not included in the RECORD ECG substudy

- All available 12-lead ECG tracings for subjects who were included in the RECORD ECG substudy and triggered for a potential MI event per automated trigger program
- All available 12-lead ECG tracings for subjects who were included in the RECORD ECG substudy and were determined to have a new Q-wave MI per substudy analysis

Both SAEs and AEs that were deleted by RECORD investigators will be identified from the audit trail of the study's electronic data sets, which GSK provided to DCRI. The electronic data sets will be sent to the DCRI before the event packet files, which include data from the CRF and source documents.

Each CEC trigger will have a unique identifier assigned to it to track each event through the CEC process.

Specific Manual Trigger Procedures will be documented in a separate document, titled RECORD Readjudication Trigger Specifications.

4.2. Collection of data. All data sent to the DCRI RECORD CEC group will have subject personal identifiers, treatment assignment, and glucose-lowering agents redacted. This will include electronic data sets as well as source documents and paper CRFs. GlaxoSmithKline is responsible for the redacting before delivery of data or documents to the DCRI. The RECORD CEC coordinators, clinical data assistant, and clinical trial assistants will ensure that information has been blinded or redacted done before sending event packets to the CEC physicians. If, during the course of DCRI activities, it is noted that information that should have been redacted was not, then the DCRI RECORD CEC coordinators, clinical data assistant, and/or clinical trial assistants will redact the information, document the event, and notify GSK. Event packets that will include the contents that were used in the original adjudication process will be provided to the CEC.

When additional information is needed to aid in the CEC adjudication, sites will be contacted directly by DCRI CEC for supporting documentation or data clarification to help render an adjudicated result. Duke Clinical Research Institute CEC will generate a request for source documents for end points that were previously adjudicated as well as for all new end points. Duke Clinical Research Institute CEC will also request any documents from sites that were missing from the previous adjudication process. Requests sent by the DCRI CEC coordinator will also be directly entered in the CEC tracking database. Sites will submit the additional information directly to the DCRI CEC RECORD e-mail inbox. The DCRI CEC coordinator will note that information was obtained using the CEC tracking form. Additional documentation that is added to event packet will be noted as "new information" at the top of the page of the source document and tracked in the CEC tracker so that

comparisons between the readjudication results and the original adjudication results will allow analysis of whether additional source documents were used during the readjudication process.

When additional source documentation is needed to support the adjudication for a suspected event, DCRI CEC will make 2 attempts to gain resolution of the request for information from the sites. If additional information is not available for an end point, the site will note that on the request form and that information will be provided in the event packet. If additional information is received after the adjudication has been completed that might affect the adjudication result, the event will be re-reviewed. The CEC adjudication form and database will be subsequently updated to reflect any changes to the initial adjudication. The DCRI will accept documents that are not in English. Duke Clinical Research Institute will contract with an independent vendor for translation services.

4.2.1. Source documents. Duke Clinical Research Institute received from GSK source documents used in event adjudication by the original RECORD Clinical Endpoints Committee. The specific documents that were requested are outlined below:

- Death—for patients who died during the RECORD study:
 - Death in hospital:
 - Death summary or
 - Investigator narrative
 - Autopsy report if available
 - Death out-of-hospital:
 - Narrative of investigator
 - Autopsy Report if available
 - Police report/family records/whatever documents could be provided to clarify the circumstances
- Hospitalization—a hospital discharge letter, or a narrative about the hospital stay from the investigator
 - Hospitalization for Acute MI
 - Hospital discharge summary including the results of the patient's ECG(s) taken during the hospital admission and results of cardiac biomarker laboratory tests.
 - If the hospital discharge summary was lacking ECG and enzyme details, a hardcopy of the ECG plus a hardcopy of the cardiac biomarker results were required. If a hard copy of the cardiac biomarker results was not available, the investigator had to complete the MI/Unstable Angina end point form (section Cardiac Biomarkers).
 - Hospitalization for Stroke
 - Hospital discharge summary with results of a neurologist's investigations provided in the discharge summary. If the discharge summary did not provide sufficient detail, the translated neurological report was requested. If the neuro-

logical report was not obtainable, the investigator summarized a verbal account from the neurologist in the end point CRF pages for stroke and transient ischemic attack (TIA).

For new events identified by the DCRI RECORD CEC Group, the following source documents are recommended:

- Death events:
 - Death summary
 - Investigator narrative
 - Autopsy report if available
- MI events:
 - Hospital discharge summary
 - Hardcopies of baseline and at least 2 event ECGs
 - Cardiac biomarker laboratory tests, including units and reference ranges
- Stroke events
 - Investigator narrative
 - Hospital discharge summary
 - Imaging study reports (magnetic resonance imaging/magnetic resonance angiography, computed tomography/computed tomography angiography)
 - Neurology consult notes

If all recommended source documents are not present and cannot be obtained from the site through the process described in Section 4.2, the event will be sent for adjudication with the available documentation.

4.3. CEC adjudication. The DCRI RECORD CEC physicians will adjudicate each suspected event using the prespecified end point criteria based on the preponderance of the evidence and clinical knowledge and experience. All events will be reviewed using the original RECORD Clinical Endpoints Committee definitions and the new definitions based on the FDA definitions (FDA Standardized Definitions for End Point Events in Cardiovascular Trials).

Potential events triggered from an adverse event term with no hospitalization or source documentation present will be reviewed by a single clinician (RECORD CEC coordinator or physician). The clinician will review the data present to determine whether or not a potential event occurred. If there are no data to support that an event occurred, a RECORD CEC Adjudication Form will be completed indicating no event. If there are data present to indicate that an event may have occurred, the event packet and data will be forwarded to phase I review for potential MI events and neurologist/phase II review for potential stroke events.

Phase I review is defined as a process whereby 2 physicians independently adjudicate each suspected event using the event criteria. The physicians will review each event using both the original RECORD Clinical Endpoints Committee definitions and the new definitions concurrently for all causes of death. Myocardial infarction events will be reviewed with a different strategy whereby 2

physicians will review each MI event independently using the original definitions, and a different set of 2 physicians will review the same MI event with the new definitions.

All events are assigned randomly to the RECORD CEC physician reviewers. The physicians will adjudicate suspected events using documentation from the CRF and available supporting source documentation. If there is insufficient documentation to determine whether an event occurred or to determine the specific classification, the CEC reviewer may ask for additional information or source documentation. In the event that 1 of the 2 reviewers requests additional information or source documentation, data or documents that have been obtained will be distributed to both reviewers.

If the phase I reviewers agree in their adjudication of the suspected event, the end point classification is complete. The final adjudication results are recorded on the RECORD CEC adjudication form and are entered into the DCRI RECORD CEC adjudication eCRF by the CEC clinical data assistant or designee. If the phase I reviewers do not agree regarding the classification of the suspected event, the event is adjudicated by phase II review.

Phase II review is a process whereby an Adjudication Committee meeting is organized comprising at least 3 faculty physicians. All disagreements from the phase I review process will be presented at the Adjudication Committee meeting of faculty members, and each event will be reviewed and a decision made by consensus of the phase II reviewers. If an event is classified as a “nonevent,” the rationale for calling it a “nonevent” will be documented on the adjudication form.

If the committee requests additional information or source documentation, then the event will be reviewed once the documentation has been obtained. The final adjudication results are recorded on a RECORD CEC adjudication form and are entered into the DCRI RECORD CEC adjudication eCRF by the CEC clinical data assistant or designee.

All suspected stroke events will be classified based on original RECORD Clinical Endpoints Committee definitions and the new definitions. All suspected strokes will be adjudicated by one of the following methods (see CEC process flow):

- Phase II committee of at least 3 RECORD CEC physicians, including a neurologist
- Initial review by neurologist, then review by phase II committee of at least 3 RECORD CEC physicians, including a neurologist
- Initial review by neurologist, then review by phase II committee of at least 3 RECORD CEC physicians, excluding neurologist. If there is a disagreement between the neurologist and the phase II committee members, the event will be re-reviewed by a phase II committee, which will consist of at least 3 RECORD CEC physicians, including a neurologist.

The final adjudication results are recorded on a RECORD CEC adjudication form and are entered into the DCRI RECORD CEC adjudication eCRF by the CEC clinical data assistant or designee.

The DCRI CEC coordinator and chairperson will determine the need for and timing of meetings of the Phase II CEC Committee. The CEC physicians will have an initial face-to-face training meeting. In addition, the members of the CEC will have face-to-face meetings and/or conference calls to adjudicate events where there was a disagreement, to perform quality control (QC) review of events, and to adjudicate difficult events. During these meetings, the CEC committee will assess and refine processes and clarify the approach to review and adjudication of complex suspected end points. Minutes of the meetings will be taken by the CEC coordinator or designee. Minutes consist of a listing of events, events adjudicated, and attendance log.

4.4. Quality control

4.4.1. Quality control of the readjudication process. A random sample of adjudicated events will be reviewed for quality by the RECORD CEC group. The CEC QC plan is based on the historical strategy of including a 5% random sample of the total number of adjudicated events, ensuring a sample large enough to have the number = [square root (total number of cases)] + 1. The random sample(s) is(are) generated by the DCRI trial statistician. The sample of events is weighted more heavily toward the earlier part of the study. The initial random sample is generated after there are 50 adjudicated events in the database. Additional random samples will be generated after the first 100, 200, and 300 mortality events are adjudicated. The same approach will be used for the MI and stroke events. A sample will be generated after 100, 200, and 300 MI or stroke events are completed.

The events selected are reviewed by RECORD CEC physicians who are blinded to the original adjudicated result. The results of the QC review are compared with the original adjudication result. These results are summarized and reviewed by the RECORD CEC chairperson, and the findings were distributed to all committee members. A “major” discrepancy occurs when there is a disagreement as to whether an event did, or did not, occur. A “minor” discrepancy occurs when there was agreement on whether an event occurred, but disagreement on the date, time, type, or evidence. Potential actions based on the results of the QC review include continuing the CEC process without modifications, readjudication of events via the CEC process, modifying the CEC process with additional QC review, and additional CEC reviewer training or removal/replacement of a CEC member per CEC chairperson. A summary report is generated by the CEC coordinator after each QC review with the findings detailed to the CEC chairperson/director. Decisions regarding the CEC process, including a recommendation

of changing the original result to that of the QC review, are made based on the QC results.

4.4.2. Quality control of the manual trigger program. A random sample of the documents that were screened during the manual trigger procedures will be rescreened to ensure the quality of the manual procedures. The QC process will include having a RECORD CEC physician rescreen the same documents that were screened by the RECORD CEC coordinators using the following metrics:

- 5% of the documents screened by the CEC coordinator will be reviewed by a physician
- 5% of manual triggers not previously reviewed in above QC effort will be reviewed by a physician
- 5% of subjects not triggered for an end point event will be selected for above QC effort

5.0. Event criteria

See [Appendices C and D](#) for event definitions.

6.0. Documentation

The following guidelines should be followed for retention of Clinical Endpoints Committee documents:

- CEC will maintain event packets for each suspected event, including query correspondence with site, source documents, and adjudication forms during the trial. Event packets will be collated by subject number and kept in a secure, locked file.
- At the end of the readjudication effort, the complete event packet, including CRF pages, adjudication forms, source documents, and queries, will be sent to the sponsor for archiving.

7. CEC process flow

See [Figures 1 and 2](#).

Appendix B. RECORD reevaluation CEC trigger specifications

This appendix provides the details and process of how subjects with suspected end point events, including death, stroke, and MI, will be identified for CEC review in the RECORD CEC Reevaluation Trial.

Suspected events for review will be identified (or “triggered”) by an electronic and manual review of the clinical data captured on the CRF. This initial set of “triggers” described in this document are based on extensive review of the protocol, CRF, and incorporation of CEC experience in prior trials. However, the development of clinical trial triggers is best viewed as an iterative process. If potential changes in the triggers are identified after cases have been reviewed, the triggers may be revised during the course of the trial with input from the clinical leadership, data management, and statistical teams as appropriate.

Appendix Table I. RECORD Reevaluation CEC electronic trigger specifications

Trigger	Form	Item	Logic	English
Death	ACE_P1 PATEND_P1 DIED_P1 TRACKWD_P1 SURVIVAL_P1 SURVIVAL_3rd_P1	OUTCOME SERCOD PATSUB DISCODE2 DCAUSE AE SUC_CONT DIEDD_DT Q_DIEDD_CH PATSTAT APDTH_DT Q_APDTH_CH CAUSEDTH	(Trigger if POPFLAG.PNRAND = Y and ACE_P1.AE is not null and ACE_P1.OUTCOME = 3 and VISIT not in(VISIT 1, VISIT2)) OR (Trigger if POPFLAG.PNRAND = Y and ACE_P1.AE is not null and ACE_P1.SERCOD3 = '1' and VISIT not in(VISIT 1, VISIT2)) OR (Trigger if POPFLAG.PNRAND = Y and PATEND_P1.PATSUB = '2' and PATEND_P1.DISCODE2 = 1 and VISIT not in(VISIT 1, VISIT2)) OR (Trigger if POPFLAG.PNRAND = Y and any(DIED_P1.DEATHTXT, DIED_P1.DEATHDAT, DIED_P1.ANSYN) is not null and VISIT not in(VISIT 1, VISIT2)) OR (Trigger if POPFLAG.PNRAND = Y and ACE_P1.PREF like any in AE PREFERRED TERM DEATH list where Flag = 3 (see next tab in spec) and VISIT not in(VISIT 1, VISIT2)) OR (Trigger if POPFLAG.PNRAND = Y and TRACKWD_P1.SUC_CONT = "D" or TRACKWD_P1.NOCNTRSN="PD" or TRACKWD_P1.DIEDD_DT is not null or TRACKWD_P1.Q_DIEDD_CH is not null and VISIT not in(VISIT 1, VISIT2)) OR (Trigger if POPFLAG.PNRAND = Y and SURVIVAL_P1.PATSTAT = '2' or SURVIVAL_P1.DIEDD_DT is not null or SURVIVAL_P1.Q_DIEDD_CH is not null or SURVIVAL_P1.CAUSEDTH is not null and VISIT not in(VISIT 1, VISIT2)) OR (Trigger if POPFLAG.PNRAND = Y and any(SURVIVAL_3RD_P1.DIED_DT, SURVIVAL_3RD_P1.Q_DIEDD_CH, SURVIVAL_3RD_P1.APDTH_DT, SURVIVAL_3RD_P1.Q_APDTH_CH, SURVIVAL_3RD_P1.CAUSEDTH, SURVIVAL_3RD_P1.DEATHSC) is not null and VISIT not in(VISIT 1, VISIT2))	Fire a trigger if the AE form has been completed and Outcome is Died OR Fire a trigger if the Serious Adverse Experience reason is "Fatal" OR Fire a trigger Study if the Continuation/Withdrawal form indicates that "Patient is withdrawing completely from the study" and the reason was "Fatal Adverse Experience" OR Fire a trigger if Form D has any data on it OR Fire a trigger if a Preferred Term matches any of those contained in the AE PREFERRED TERM DEATH listing OR Fire a trigger if the Tracking Form for Completely Withdrawn Patients indicates that a completely withdrawn patient is reported dead OR Fire a trigger if the Survival Status Form indicates that a patient is dead at final contact OR Fire a trigger if the Documentation of Third Party Survival Data Form has any indication of death
MI	CVPAMPEP_P1 ACE_P1 ECGINT_P1	CVAMPRSN AE CHANGEYN ANYYN	(Trigger if POPFLAG.PNRAND = Y and CVPAMPEP_P1.ICP_T in(1, 2) and CVPAMPEP_P1.ICP_ART = 1 and VISIT not in(VISIT 1, VISIT2)) OR (Trigger if POPFLAG.PNRAND = Y and ACE_P1.PREF like any in AE PREFERRED TERM MI list where Flag = 1 (see next tab in spec) and VISIT not in(VISIT 1, VISIT2))	Fire a trigger if the Invasive Cardiovascular Procedure/Amputation end point form specifies the type of procedure was Surgical or Nonsurgical and the artery in which the procedure was performed was indicated as Coronary OR Fire a trigger if a Preferred Term matches any of those contained in the AE PREFERRED TERM listing

(continued on next page)

Appendix Table I (continued)

Trigger	Form	Item	Logic	English
Stroke	ACE_P1	AE	Trigger if POPFLAG.PNRAND = Y and ACE_P1.PREF like any in AE PREFERRED TERM STROKE list where Flag = 2 (see next tab in spec) and VISIT not in(VISIT 1, VISIT2) OR Trigger if POPFLAG.PNRAND = Y and CVPAMPEP_P1.ICP_T in(1, 2) and CVPAMPEP_P1.ICP_ART = 2 and VISIT not in(VISIT 1, VISIT2)	Fire a trigger if a Preferred Term matches any of those contained in the AE PREFERRED TERM listing Fire a trigger if Invasive Cardiovascular Procedure/Amputation end point form specifies that type of procedure was Surgical or Nonsurgical and the artery in which the procedure was performed was indicated as Carotid

Electronic triggers

See Appendix Table I for detailed specifications.

Death

- Trigger for Death event if Adverse Event (AE) Form has been completed and Outcome is Died.
- Trigger for Death event if Serious Adverse Experience (SAE) reason is Fatal.
- Trigger for Death event if Form D (Death Form) has any data on it
- Trigger for Death event if Study Discontinuation/Withdrawal Form indicates “Patient is withdrawing completely from the study,” and the reason is “Fatal Adverse Experience.”
- Trigger for Death event if AE Form or SAE Form Preferred Term matches any of those listed on the Death Preferred Term Listing (Appendix Table II).
- Trigger for a Death event if Tracking Form for Completely Withdrawn Patients indicates that a patient is reported dead.
- Trigger for a Death event if Survival Status Form indicates the patient is dead.
- Trigger for a Death event if Third Party Survival Data Form indicates that patient has died.

Myocardial infarction (MI)

- Trigger for MI event if Invasive Cardiovascular Procedure/Amputation Form specifies the type of procedure as Surgical or Nonsurgical and the artery indicated is Coronary.
- Trigger for MI event if AE Form or SAE Form Preferred Term matches any of those listed on the MI Preferred Term Listing (Appendix Table III).

Stroke

- Trigger for Stroke event if AE Form or SAE Form Preferred Term matches any of those listed on the Stroke Preferred Term Listing (Appendix Table IV).

- Trigger for Stroke event if Invasive Cardiovascular Procedure/Amputation Form specifies the type of procedure as Surgical or Nonsurgical and the artery indicated is Carotid.

Electronic data listings

The following data listing has been electronically extracted from the database to identify potential events. Each data point listed will be screened by a RECORD CEC clinical trial coordinator to determine if the potential event requires CEC adjudication. Documentation that the data have been screened will be maintained on the Data Listing spreadsheet, along with the CEC trigger number, for the potential events sent for CEC adjudication.

- Serious Adverse Experiences deleted from database
- Serious Adverse Experiences changed in the database
- Abnormal ECGs and AE/SAE with onset date \pm 14 days of ECG date
- Hospitalization and AE/SAE with onset date \pm 14 days of hospital admission date
- Patients who started new cardiac medications (thrombolytics, intravenous IIB/IIIa inhibitors, and intravenous heparin) during the study
- Patients who withdrew from Randomized Treatment phase of the study because of safety risk, admittance to a long-term health care facility, or other reason
- Patients who withdrew completely from study and specified “other” reason

Manual triggers

The RECORD CEC clinical trial coordinators will perform a manual review of paper documents for each subject to identify potential events. Documentation that the paper sources were manually screened will be maintained via spreadsheet listing all enrolled subjects. Paper sources that the CEC coordinators will review include, but are not limited to, the following:

- Unscheduled Visit Form
- Hospitalization or Accident and Emergency Department Visit End Point Form
- Source documents
- AE and SAE Forms (containing investigator verbatim terms)
- All Endpoints that were sent to original RECORD Clinical End Point Committee
- Death End Point Forms
- MI/Unstable Angina End Point Forms
- Stroke/TIA End Point Forms
- Hospitalizations
- Survival Status Forms
- Third Party Survival Data Forms
- Tracking Forms for Completely Withdrawn Patients
- Study Completion Forms
- Concomitant Medication Forms

Appendix C. Original RECORD end point definitions

Death

1.0. Definition of cardiovascular death end points.

Cardiovascular death shall be defined as any death for which an unequivocal noncardiovascular cause cannot be established. Cardiovascular death will include death after heart failure, death after acute MI, sudden death, and death due to acute vascular events. Deaths that are due to unknown causes (and therefore cannot be categorized into the categories listed below) will be classified as “unknown deaths” but will be counted as cardiovascular deaths for the analysis of the “primary end point.”

1.1. *Death after heart failure.* This is defined as death due to the onset and progression of symptoms defining definite heart failure (as listed in the present charter).

1.2. *Death after MI.* This is defined as death within 30 days after acute MI.

1.3. *Sudden death.* This is defined as death due to one of the following reasons:

- within 1 hour after onset of new symptoms
- witnessed death, without new symptoms occurring within 72 hours preceding death
- cardiac arrest followed by death within 30 days even if temporarily recovered
- unwitnessed death in the absence of new symptoms*

1.4. *Death due to acute vascular events.* This is defined as death due to aortic dissection, aortic aneurysm, pulmonary embolism, stroke, or any other vascular cause.

* The premise for the death to be adjudicated in this category is that it is known that the patients did not have any signs or symptoms 24 hours before the death occurred; otherwise, it will constitute a death of unknown cause.

Appendix Table II. Death AE/SAE preferred terms

Flag: 3 = death	Preferred term
3	Cardiac arrest
3	Brain death
3	Death
3	Drowning
3	Multorgan failure
3	Sudden cardiac death
3	Sudden death
3	Intentional overdose
3	Overdose
3	Road traffic accident
3	Completed suicide
3	Asphyxia
3	Respiratory failure
3	Cardiac fibrillation
3	Appendicitis perforated
3	Diverticular perforation
3	Duodenal perforation
3	Food poisoning
3	Gastric ulcer perforation
3	Intestinal perforation
3	Peptic ulcer perforation
3	Peritonitis
3	Anaphylactic reaction
3	Meningitis viral
3	Accidental overdose
3	Wound dehiscence
3	Adenocarcinoma
3	Breast cancer metastatic
3	Colon cancer stage iii
3	Hepatic cancer metastatic
3	Lung cancer metastatic
3	Metastases to abdominal cavity
3	Metastases to bone
3	Metastases to breast
3	Metastases to central nervous system
3	Metastases to liver
3	Metastases to lung
3	Metastases to lymph nodes
3	Metastases to peritoneum
3	Metastases to spine
3	Metastatic malignant melanoma
3	Metastatic neoplasm
3	Metastatic renal cell carcinoma
3	Ovarian cancer metastatic
3	Pancreatic carcinoma
3	Pancreatic carcinoma stage IV
3	Rectal cancer metastatic
3	Suicide attempt
3	Bladder perforation
3	Choking
3	Pulmonary embolism
3	Respiratory distress
3	Aortic aneurysm rupture
3	Hypovolaemic shock
3	Shock hemorrhagic

Myocardial Infarction

2.0. Hospitalization for acute MI. Acute MI will be adjudicated according to the definition in the document: “myocardial infarction redefined—a consensus document of The Joint European Society of Cardiology/American

Appendix Table III. MI AE/SAE preferred terms

Flag: 1 = MI	Preferred term
1	Acute coronary syndrome
1	Acute MI
1	Angina pectoris
1	Angina unstable
1	Arteriosclerosis coronary artery
1	Atrioventricular block complete
1	Bundle-branch block left
1	Cardiac aneurysm
1	Cardiac discomfort
1	Cardiac disorder
1	Cardiac failure
1	Cardiac failure acute
1	Cardiac failure congestive
1	Cardiomegaly
1	Cardiomyopathy
1	Cardiovascular disorder
1	Coronary artery disease
1	Coronary artery insufficiency
1	Coronary artery occlusion
1	Coronary artery stenosis
1	Ischemic cardiomyopathy
1	Myocardial fibrosis
1	Myocardial ischemia
1	Postinfarction angina
1	Prinzmetal angina
1	Silent MI
1	Ventricular dysfunction
1	Ventricular fibrillation
1	Ventricular tachycardia
1	Chest discomfort
1	Chest pain
1	Pain
1	Myocardial abscess
1	Cardiac procedure complication
1	Cardiac valve replacement complication
1	In-stent arterial restenosis
1	Stent occlusion
1	Blood creatine phosphokinase increased
1	Cardiac stress test
1	ECG signs of myocardial ischemia
1	Electrocardiogram abnormal
1	Electrocardiogram change
1	Electrocardiogram low voltage
1	Electrocardiogram Q waves
1	Electrocardiogram ST segment abnormal
1	Electrocardiogram ST segment depression
1	Electrocardiogram ST segment elevation
1	Electrocardiogram ST-T change
1	Electrocardiogram T wave abnormal
1	Electrocardiogram T wave inversion
1	Exercise electrocardiogram abnormal
1	Acute pulmonary edema
1	Dyspnea at rest
1	Dyspnea exertional
1	Dyspnea paroxysmal nocturnal
1	Nocturnal dyspnea
1	Orthopnea
1	Arterial occlusive disease
1	Cardiovascular insufficiency
1	Circulatory collapse
1	Ischemia
1	Shock

Appendix Table III (continued)

Flag: 1 = MI	Preferred term
1	Arrhythmia
1	Atrioventricular block
1	Atrioventricular block second degree
1	Bradycardia
1	Bradyarrhythmia
1	Bradycardia
1	Bundle-branch block
1	Bundle-branch block bilateral
1	Bundle-branch block right
1	Congestive cardiomyopathy
1	Left ventricular failure
1	Right ventricular failure
1	Sinus bradycardia
1	Tachycardia
1	Tachycardia
1	Ventricular arrhythmia
1	Generalized edema
1	Pulmonary edema
1	Arterial stenosis
1	MI

College of Cardiology Committee for the Redefinition of Myocardial Infarction,⁵

Hospitalization plus biochemical markers as defined below:

Elevation of cardiac biomarkers troponin I and/or troponin T above ULN or CK-MB isoenzyme $\geq 2 \times$ ULN or creatine kinase (CK) $> 2 \times$ ULN.

Plus one of the following:

- (i) Typical symptoms of cardiac ischemia
- (ii) New pathological electrocardiogram findings as defined in *Eur Heart J* 2000;21:1502-13⁵

Stroke

3.1. Hospitalization for stroke. Whenever possible the disease should be confirmed by a neurologist or by computed tomography or magnetic resonance imaging.

Hospitalization plus:

Rapidly developed clinical signs of focal (or global [global applies to patients with subarachnoid hemorrhage or deep coma but excluding coma of systemic vascular origin such as shock, Stokes-Adams syndrome, or hypertensive encephalopathy]) disturbance of cerebral function lasting more than 24 hours (unless interrupted by thrombolysis, surgery, or death), with no apparent cause other than a vascular origin: it includes patients presenting clinical signs and symptoms suggestive of subarachnoid hemorrhage, intracerebral hemorrhage, or cerebral ischemic necrosis.

Secondary stroke events resulting from blood diseases (eg, leukemia, polycythemia vera), as well as stroke symptoms from brain tumors or brain metastases, should be excluded. Secondary stroke caused by trauma and other disorders (eg, metabolic disturbance) or peripheral lesion that could cause a localizing neurologic deficit or coma should also be excluded.

Definite focal signs:

Appendix Table IV. Stroke AE/SAE preferred terms

Flag: 2 = stroke	Preferred term
2	Deafness
2	Deafness bilateral
2	Deafness neurosensory
2	Deafness unilateral
2	Vestibular ataxia
2	Blindness
2	Diplopia
2	Retinal infarction
2	Retinal ischemia
2	Retinal vascular thrombosis
2	Retinal vein occlusion
2	Retinal vein thrombosis
2	Dysphagia
2	Gait disturbance
2	Brain contusion
2	Concussion
2	Head injury
2	Traumatic brain injury
2	Carotid bruit
2	Aphasia
2	Ataxia
2	Balance disorder
2	Carotid arteriosclerosis
2	Carotid artery stenosis
2	Cerebral infarction
2	Cerebral venous thrombosis
2	Cerebrovascular accident
2	Cerebrovascular disorder
2	Cerebrovascular insufficiency
2	Coordination abnormal
2	Dysarthria
2	Dysphasia
2	Hemiparesis
2	Hemiplegia
2	Hypokinesia
2	Hypotonia
2	Ischemic cerebral infarction
2	Ischemic stroke
2	Lacunar infarction
2	Paralysis
2	Transient ischemic attack
2	Vertebrobasilar insufficiency
2	Subdural hematoma
2	Brain edema
2	Cerebral hemorrhage
2	Cerebral ischemia
2	Hemorrhage intracranial
2	Hemorrhagic stroke
2	Intracranial hematoma
2	Ruptured cerebral aneurysm

- Unilateral or bilateral motor impairment (including dyscoordination)
- Unilateral or bilateral sensory impairment
- Aphasia/dysphasia (nonfluent speech)
- Hemianopia (half-sided impairment of visual fields)
- Diplopia
- Forced gaze (conjugate deviation)
- Dysphagia of acute onset
- Apraxia of acute onset
- Ataxia of acute onset
- Perception deficit of acute onset

Not acceptable as sole evidence of focal dysfunction:

- Dizziness, vertigo
- Localized headache
- Blurred vision of both eyes
- Dysarthria (slurred speech)
- Impaired cognitive function (including confusion)
- Impaired consciousness
- Seizures

(Although strokes can present in this way, these signs are not specific and cannot therefore be accepted as definite evidence for stroke.)

Appendix D. FDA end point definitions

Death

The determination of the specific cause of cardiovascular death is complicated by the fact that we are particularly interested in one underlying cause of death (acute MI [AMI]) and several modes of death (arrhythmia and heart failure/low output). It is noted that heart attack-related deaths are manifested as sudden death or heart failure, so these events need to be carefully defined.

Cardiovascular death includes death resulting from an AMI, sudden cardiac death, death due to heart failure, death due to stroke, and death due to other cardiovascular causes, as follows:

1. *Death due to Acute MI* refers to a death by any mechanism (arrhythmia, heart failure, low output) within 30 days after an MI related to the immediate consequences of the MI, such as progressive congestive heart failure (CHF), inadequate cardiac output, or recalcitrant arrhythmia. If these events occur after a “break” (eg, a CHF- and arrhythmia-free period of at least a week), they should be designated by the immediate cause, although the MI may have increased the risk of that event (eg, late arrhythmic death becomes more likely after an AMI). The AMI should be verified to the extent possible by the diagnostic criteria outlined for AMI or by autopsy findings showing recent MI or recent coronary thrombus. Sudden cardiac death, if accompanied by symptoms suggestive of myocardial ischemia, new ST elevation, new left bundle-branch block, or evidence of fresh thrombus by coronary angiography and/or at autopsy, should be considered death resulting from an acute MI, even if death occurs before blood samples or 12-lead electrocardiogram (ECG) could be obtained, or at a time before the appearance of cardiac biomarkers in the blood.

Death resulting from a procedure to treat an MI (percutaneous coronary intervention [PCI], coronary artery bypass graft surgery [CABG]), or to treat a complication resulting from MI, should also be considered death due to acute MI.

Death resulting from a procedure to treat myocardial ischemia (angina) or death due to an MI that occurs as a direct consequence of a cardiovascular investigation/procedure/operation should be considered as a death due to other cardiovascular causes.

2. *Sudden cardiac death* refers to a death that occurs unexpectedly, not following an AMI, and includes the following deaths:

- Death witnessed and instantaneous without new or worsening symptoms
- Death witnessed within 60 minutes of the onset of new or worsening cardiac symptoms, unless the symptoms suggest AMI
- Death witnessed and attributed to an identified arrhythmia (eg, captured on an ECG recording, witnessed on a monitor, or unwitnessed but found on implantable cardioverter-defibrillator review)
- Death after unsuccessful resuscitation from cardiac arrest
- Death after successful resuscitation from cardiac arrest and without identification of a noncardiac etiology (postcardiac arrest syndrome)
- Unwitnessed death without other cause of death (information regarding the patient's clinical status preceding death should be provided, if available)

General considerations

- A subject seen alive and clinically stable 12 to 24 hours before being found dead without any evidence or information of a specific cause of death should be classified as “sudden cardiac death.” Typical scenarios include the following:
 - Subject well the previous day but found dead in bed the next day
 - Subject found dead at home on the couch with the television on
 - Deaths for which there is no information beyond “Patient found dead at home” may be classified as “death due to other cardiovascular causes” or in some trials, “undetermined cause of death.” Please see “Definition of Undetermined Cause of Death” section below for full details.
3. *Death due to heart failure or cardiogenic shock* refers to a death occurring in the context of clinically worsening symptoms and/or signs of heart failure without evidence of another cause of death and not after an AMI. Note that deaths due to heart failure can have various etiologies, including 1 or more AMIs (late effect), ischemic or nonischemic cardiomyopathy, or valve disease.

Death due to heart failure or cardiogenic shock should include sudden death occurring during an admission for

worsening heart failure as well as death from progressive heart failure or cardiogenic shock after implantation of a mechanical assist device. New or worsening signs and/or symptoms of CHF include any of the following:

- a. New or increasing symptoms and/or signs of heart failure requiring the initiation of, or an increase in, treatment directed at heart failure or occurring in a patient already receiving maximal therapy for heart failure
- b. Heart failure symptoms or signs requiring continuous intravenous therapy or chronic oxygen administration for hypoxia caused by pulmonary edema
- c. Confinement to bed predominantly caused by heart failure symptoms
- d. Pulmonary edema sufficient to cause tachypnea and distress not occurring in the context of an acute MI or worsening renal function, or as the consequence of an arrhythmia occurring in the absence of worsening heart failure
- e. Cardiogenic shock not occurring in the context of an AMI or as the consequence of an arrhythmia occurring in the absence of worsening heart failure

Cardiogenic shock is defined as systolic blood pressure is <90 mm Hg for greater than 1 hour, not responsive to fluid resuscitation and/or heart rate correction, and felt to be secondary to cardiac dysfunction and associated with at least one of the following signs of hypoperfusion:

- Cool, clammy skin or
- Oliguria (urine output <30 mL/h) or
- Altered sensorium or
- Cardiac index < 2.2 L min⁻¹ m⁻²

Cardiogenic shock can also be defined if systolic blood pressure is <90 mm Hg and increases to ≥90 mm Hg in less than 1 hour with positive inotropic or vasopressor agents alone and/or with mechanical support.

General considerations

Heart failure may have a number of underlying causes including acute or chronic ischemia, structural heart disease (eg, hypertrophic cardiomyopathy), and valvular heart disease. Where treatments are likely to have specific effects and it is likely to be possible to distinguish between the various causes, then it may be reasonable to separate out the relevant treatment effects. For example, obesity drugs such as fenfluramine (pondimin) and dexfenfluramine (redux) were found to be associated with the development of valvular heart disease and pulmonary hypertension. In other cases, the aggregation implied by the definition above may be more appropriate.

4. *Death due to stroke* refers to death occurring up to 30 days after a stroke that is either caused by the stroke or caused by a complication of the stroke.

5. *Death due to other cardiovascular causes* refers to a cardiovascular death not included in the above categories (eg, dysrhythmia unrelated to sudden cardiac death, pulmonary embolism, cardiovascular intervention [other than one related to an AMI], aortic aneurysm rupture, or peripheral arterial disease). Mortal complications of cardiac surgery or nonsurgical revascularization should be classified as cardiovascular deaths.

Definition of noncardiovascular death. *Noncardiovascular death* is defined as any death that is not thought to be due to a cardiovascular cause. Detailed recommendations on the classification of noncardiovascular causes of death are beyond the scope of this document. The level of detail required and the optimum classification will depend on the nature of the study population and the anticipated number and type of noncardiovascular deaths. Any specific anticipated safety concern should be included as a separate cause of death. The following is a suggested list of noncardiovascular** causes of death:

Nonmalignant causes

- Pulmonary
- Renal
- Gastrointestinal
- Hepatobiliary
- Pancreatic
- Infection (includes sepsis)
- Noninfectious (eg, systemic inflammatory response syndrome)
- Hemorrhage, not intracranial
- Noncardiovascular system organ failure (eg, hepatic failure)
- Noncardiovascular surgery
- Other noncardiovascular, specify: _____
- Accidental/trauma
- Suicide
- Drug overdose

Malignant causes

Malignancy should be coded as the cause of death if:

- death results directly from the cancer; or
- death results from a complication of the cancer (eg, infection, complication of surgery/chemotherapy/radiotherapy); or
- death results from withdrawal of other therapies because of concerns relating to the poor prognosis associated with the cancer.

Cancer deaths may arise from cancers that were present before randomization or which developed subsequently. It may be helpful to distinguish these 2 scenarios (ie, worsening of prior malignancy, new malignancy).

** Death due to a gastrointestinal bleed should *not* be considered a cardiovascular death.

Suggested categorization includes common organ systems, hematologic, or unknown.

Definition of undetermined cause of death. *Undetermined cause of death* refers to a death not attributable to one of the above categories of cardiovascular death or to a noncardiovascular cause. Inability to classify the cause of death may be due to lack of information (eg, the only available information is “patient died”) or when there is insufficient supporting information or detail to assign the cause of death. In general, the use of this category of death should be discouraged and should apply to a minimal number of patients in well-run clinical trials.

A common analytic approach for cause of death analyses is to assume that all undetermined cases are included in the cardiovascular category (eg, presumed cardiovascular death, specifically “death due to other cardiovascular causes”). Nevertheless, the appropriate classification and analysis of undetermined causes of death depend on the population, the intervention under investigation, and the disease process. The approach should be prespecified and described in the protocol and other trial documentation such as the end point adjudication procedures and/or the SAP.

Myocardial infarction

1. *General considerations.* The term *MI* should be used when there is evidence of myocardial necrosis in a clinical setting consistent with myocardial ischemia.

In general, the diagnosis of MI requires the combination of:

- evidence of myocardial necrosis (either changes in cardiac biomarkers or postmortem pathological findings); and
- supporting information derived from the clinical presentation, ECG changes, or the results of myocardial or coronary artery imaging.

The totality of the clinical, ECG, and cardiac biomarker information should be considered to determine whether or not an MI has occurred. Specifically, timing and trends in cardiac biomarkers and ECG information require careful analysis. The adjudication of MI should also take into account the clinical setting in which the event occurs. Myocardial infarction may be adjudicated for an event that has characteristics of an MI but which does not meet the strict definition because biomarker or ECG results are not available.

2. *Criteria for MI.*

a. *Clinical presentation*

The clinical presentation should be consistent with diagnosis of myocardial ischemia and infarction. Other findings that might support the diagnosis of MI should be taken into account because a number of conditions are associated with elevations in cardiac biomarkers (eg, trauma, surgery, pacing, ablation, congestive heart failure, hypertrophic cardiomyopathy, pulmonary

embolism, severe pulmonary hypertension, stroke or subarachnoid hemorrhage, infiltrative and inflammatory disorders of cardiac muscle, drug toxicity, burns, critical illness, extreme exertion, and chronic kidney disease). Supporting information can also be considered from myocardial imaging and coronary imaging. The totality of the data may help differentiate acute MI from the background disease process.

b. Biomarker elevations

For cardiac biomarkers, laboratories should report an upper reference limit (URL). If the 99th percentile of the URL from the respective laboratory performing the assay is not available, then the URL for myocardial necrosis from the laboratory should be used. If the 99th percentile of the URL or the URL for myocardial necrosis is not available, the MI decision limit for the particular laboratory should be used as the URL. Laboratories can also report both the 99th percentile of the upper reference limit and the MI decision limit. Reference limits from the laboratory performing the assay are preferred over the manufacturer's listed reference limits in an assay's instructions for use. Creatine kinase-MB (CK-MB) and troponin are preferred, but CK may be used in the absence of CK-MB and troponin.

For MI subtypes, different biomarker elevations for CK, CK-MB, or troponin will be required. The specific criteria will be referenced to the URL.

In many studies, particularly those in which patients present acutely to hospitals which are not participating sites, it is not practical to stipulate the use of a single biomarker or assay, and the locally available results are to be used as the basis for adjudication. However, if possible, using the same cardiac biomarker assay, and preferably a core laboratory, for all measurements reduces interassay variability.

Because the prognostic significance of different types of MIs (eg, periprocedural MI versus spontaneous MI) may be different, consider evaluating outcomes for these subsets of patients separately.

c. ECG changes

Electrocardiographic changes can be used to support or confirm an MI. Supporting evidence may be ischemic changes, and confirmatory information may be new Q waves:

- Criteria for acute myocardial ischemia (in the absence of left ventricular hypertrophy and left bundle-branch block)
 - ST elevation
 - New ST elevation at the J point in 2 anatomically contiguous leads with the cutoff points ≥ 0.2 mV in men (>0.25 mV in men younger than 40 years) or ≥ 0.15 mV in women in leads V_2 to V_3 and/or ≥ 0.1 mV in other leads
 - ST depression and T-wave changes
 - New horizontal or downsloping ST depression

≥ 0.05 mV in 2 contiguous leads, and/or new T inversion ≥ 0.1 mV in 2 contiguous leads

The above ECG criteria illustrate patterns consistent with myocardial ischemia. In patients with abnormal biomarkers, it is recognized that lesser ECG abnormalities may represent an ischemic response and may be accepted under the category of abnormal ECG findings.

- Criteria for pathological Q wave
 - Any Q wave in leads V_2 to V_3 ≥ 0.02 seconds or QS complex in leads V_2 and V_3
 - Q wave ≥ 0.03 seconds and ≥ 0.1 mV deep or QS complex in leads I, II, aVL, aVF, or V_4 to V_6 in any 2 leads of a contiguous lead grouping (I, aVL, V_6 ; V_4 - V_6 ; II, III, and aVF)
 - The same criteria are used for supplemental leads V_7 to V_9 and for the Cabrera frontal plane lead grouping.
- Criteria for prior MI
 - Pathological Q waves, as defined above
 - R wave ≥ 0.04 seconds in V_1 to V_2 and $R/S \geq 1$ with a concordant positive T wave in the absence of a conduction defect

3. *MI subtypes.* Several MI subtypes are commonly reported in clinical investigations, and each is defined below:

a. Spontaneous MI

1. Detection of rise and/or fall of cardiac biomarkers with at least 1 value above the URL with at least 1 of the following:
 - Clinical presentation consistent with ischemia
 - ECG evidence of acute myocardial ischemia
 - New pathological Q waves
 - Imaging evidence of new loss of viable myocardium or new regional wall motion abnormality
 - Autopsy evidence of AMI
2. If biomarkers are elevated from a prior infarction, then a spontaneous MI is defined as follows:

a. One of the following:

- Clinical presentation consistent with ischemia
- ECG evidence of acute myocardial ischemia
- New pathological Q waves
- Imaging evidence of new loss of viable myocardium or new regional wall motion abnormality
- Autopsy evidence of AMI

AND

b. Both of the following:

- Evidence that cardiac biomarker values were decreasing (eg, 2 samples 3-6 hours apart) before the suspected MI[†]
- $\geq 20\%$ increase (and $>$ URL) in troponin or CK-MB between a measurement made at the time of the initial presentation and a further sample taken 3 to 6 hours later

[†] If biomarkers are increasing or peak is not reached, then a definite diagnosis of recurrent MI is generally not possible.

b. Percutaneous coronary intervention–related MI

Peri-PCI MI is defined by any of the following criteria. Symptoms of cardiac ischemia are not required.

1. Biomarker elevations within 48 hours of PCI:

- Troponin or CK-MB (preferred) > 3× URL *and*
- No evidence that cardiac biomarkers were elevated before the procedure;

OR

- Both of the following must be true:
 - ≥50%[‡] increase in the cardiac biomarker result
 - Evidence that cardiac biomarker values were decreasing (eg, 2 samples 3-6 hours apart) before the suspected MI

2. New pathological Q waves

3. Autopsy evidence of acute MI

c. Coronary artery bypass grafting–related MI

Peri-coronary artery bypass graft surgery (CABG) MI is defined by the following criteria. Symptoms of cardiac ischemia are not required.

1. Biomarker elevations within 72 hours of CABG:

- Troponin or CK-MB (preferred) > 5× URL *and*
- No evidence that cardiac biomarkers were elevated before the procedure;

OR

- Both of the following must be true:
 - ≥50%[§] increase in the cardiac biomarker result
 - Evidence that cardiac biomarker values were decreasing (eg, 2 samples 3-6 hours apart) before the suspected MI

AND

2. One of the following:

- New, pathological Q waves persistent through 30 days
- New, persistent, non-rate-related LBBB
- Angiographically documented new graft or native coronary artery occlusion
- Other complication in the operating room resulting in loss of myocardium
- Imaging evidence of new loss of viable myocardium

OR

3. Autopsy evidence of acute MI

d. Silent MI

Silent MI is defined by the following:

1. No evidence of acute MI

AND

2. Any one of the following criteria:

- New pathological Q waves. A confirmatory ECG is recommended if there have been no clinical symptoms or history of MI.

- Imaging evidence of a region of loss of viable myocardium that is thinned and fails to contract, in the absence of a nonischemic cause
- Autopsy evidence of a healed or healing MI

Common classification schemes for MI categories. For some trials, categorization of MI end points may be helpful or necessary using 1 or more of the classification schemes below:

1. By the universal MI definition:

a. Clinical classification of different types of MI

• *Type 1*

Spontaneous MI related to ischemia caused by a primary coronary event such as plaque erosion and/or rupture, fissuring, or dissection

• *Type 2*

MI secondary to ischemia caused by either increased oxygen demand or decreased supply, for example, coronary artery spasm, coronary embolism, anemia, arrhythmias, hypertension, or hypotension

• *Type 3*

Sudden unexpected cardiac death, including cardiac arrest, often with symptoms suggestive of myocardial ischemia, accompanied by presumably new ST elevation, or new LBBB, or evidence of fresh thrombus in a coronary artery by angiography and/or at autopsy, but death occurring before blood samples could be obtained, or at a time before the appearance of cardiac biomarkers in the blood

• *Type 4a*

MI associated with PCI

• *Type 4b*

MI associated with stent thrombosis as documented by angiography or at autopsy

• *Type 5*

MI associated with CABG

b. Sample clinical trial tabulation of randomized patients by types of MI

Types of MI	Treatment A: no. of patients (N)	Treatment B: no. of patients (N)
MI type 1	n, %	n, %
MI type 2	n, %	n, %
MI type 3	n, %	n, %
MI type 4	n, %	n, %
MI type 5	n, %	n, %
Total no.	n, %	n, %

N, total number of patients; n, number of patients with a particular MI.

2. By electrocardiographic features:

• **ST-elevation MI**

- Additional subcategories may include the following:
 - The following:

[‡] Data should be collected in such a way that analyses using ≥20% or ≥50% could both be performed.

[§] Data should be collected in such a way that analyses using ≥20% or ≥50% could both be performed.

Classification of the different types of MI According to multiples of the 99th percentile URL of the applied cardiac biomarker

Multiples x 99%	MI type 1 (spontaneous)	MI type 2 (secondary)	MI type 3 [†] (sudden death)	MI type 4 [†] (PCI)	MI type 5 [†] (CABG)	Total no.
1-2x						
>2-3x						
>3-5x						
>5-10x						
>10x						
Total no.						

The hatched areas represent biomarker elevations below the decision limit used for these types of myocardial infarction.

* Biomarkers are not available for this type of MI because the patients expired before biomarker determination could be performed.

† For the sake of completeness, the total distribution of biomarker values should be reported. The hatched areas represent biomarker elevations below the decision limit used for these types of MI.\

- Q wave
- Non-Q wave
- Unknown (no ECG or ECG not interpretable)
- Non-ST-elevation MI
 - Additional subcategories may include the following:
 - Q wave
 - Non-Q wave
 - Unknown (no ECG or ECG not interpretable)
- Unknown (no ECG or ECG not interpretable)

3. By biomarker elevation (per universal MI definition):

The magnitude of cardiac biomarker elevation can be calculated as a ratio of the peak biomarker value divided by the 99th percentile URL.

The biomarker elevation can be provided for various MI subtypes, as shown in the example below.

Stroke

1. *Stroke.* Stroke is defined as an acute episode of neurologic dysfunction caused by focal or global brain, spinal cord, or retinal vascular injury.

Classification

A. Ischemic stroke

Ischemic stroke is defined as an acute episode of focal cerebral, spinal, or retinal dysfunction caused by an infarction of central nervous system tissue. Hemorrhage may be a consequence of ischemic stroke. In this situation, the stroke is an ischemic stroke with hemorrhagic transformation and not a hemorrhagic stroke.

B. Hemorrhagic stroke

Hemorrhagic stroke is defined as an acute episode of focal or global cerebral or spinal dysfunction caused by a nontraumatic intraparenchymal, intraventricular, or subarachnoid hemorrhage.

C. Undetermined stroke

Undetermined stroke is defined as a stroke with insufficient information to allow categorization as A or B.

2. *Stroke Disability.* Stroke disability should be measured by a reliable and valid scale in all cases. For example, the

modified Rankin Scale may be used to address this requirement.

Scale	Disability
0	No symptoms at all
1	No significant disability despite symptoms; able to carry out all usual duties and activities
2	Slight disability; unable to carry out all previous activities, but able to look after own affairs without assistance
3	Moderate disability; requiring some help, but able to walk without assistance
4	Moderately severe disability; unable to walk without assistance and unable to attend to own bodily needs without assistance
5	Severe disability; bedridden, incontinent, and requiring constant nursing care and attention
6	Dead

Additional considerations. In trials involving patients with stroke, evidence of vascular central nervous system injury without recognized neurologic dysfunction may be observed. Examples include microhemorrhage, silent infarction, and silent hemorrhage. When encountered, the clinical relevance of these findings may be unclear. If appropriate for a given clinical trial, however, they should be precisely defined and categorized.

The distinction between a transient ischemic attack and an ischemic stroke is the presence of infarction, not the transience of the symptoms. In addition to laboratory documentation of infarction, persistence of symptoms is an acceptable indicator of infarction. Thus, symptom transience should be defined for any clinical trial in which it will be used to distinguish between transient ischemia and infarction.

Appendix E. Statistical analysis plan, DCRI independent review, and readjudication of the RECORD trial, first phase (mortality)

Prepared by

Gail Hafley (Senior Statistician, DCRI)

Robert Bigelow (Associate Director of Statistics, DCRI)

July 13, 2011
Duke Clinical Research Institute

1. Abbreviations

Abbreviation	Definition
CEC	Clinical events classification
Cox PH	Cox proportional hazard (model)
CV	Cardiovascular
CVFU	Cardiovascular follow-up
DCRI	Duke Clinical Research Institute
FDA	US Food and Drug Administration
GSK	GlaxoSmithKline
MACE	Major adverse cardiac end points
MET	Metformin
MI	Myocardial infarction
RDTP	Randomized dual-treatment phase
RECORD	Rosiglitazone Evaluated for Cardiac Outcomes and Regulation of glycaemia in Diabetes
RSG	Rosiglitazone
RTP	Randomized treatment phase
SAP	Statistical analysis plan
SSFU	Survival status follow-up
SU	Sulphonylurea

2. Introduction

The readjudication/reanalysis of RECORD data is planned to be done in 2 phases. In the first phase, DCRI will screen RECORD data to identify deaths and classify each death according to cause (cardiovascular [CV], non-CV, or unknown). In the second phase, possible occurrences of nonfatal MI and nonfatal stroke will be identified and adjudicated.

This document describes planned statistical analyses of the first phase (mortality) only.

2.1. Background. The RECORD study was a long-term, open-label, randomized clinical trial in patients with type 2 diabetes, comparing the effects of the combination of rosiglitazone and either metformin or sulphonylurea with metformin plus sulphonylurea on cardiovascular end points and glycaemia. The results of RECORD have been published,² and study data have been submitted to the FDA.

Food and Drug Administration review of the RECORD trial raised questions about the “potential bias in identification of cardiovascular events due to the open-label design.”²⁴ The FDA has requested an independent review of RECORD data and updated analyses for the specific end points all-cause mortality, cardiovascular mortality, major adverse cardiac end points (MACEs), and the individual components of MACE. GlaxoSmithKline has contracted DCRI to perform the independent review.

The Duke Clinical Research Institute plans to perform the review and readjudication in 2 phases, as described in DCRI Readjudication Protocol AVD115170 (Version 1.0; January 28, 2011). The first phase will focus on mortality

(all-cause, cardiovascular, and noncardiovascular) end points, and the second phase will include analysis of the end points of MI (fatal and nonfatal), stroke (fatal and nonfatal), and MACE. Appendix I of Protocol AVD115170 contains the initial SAP describing the general approach to be taken in the analysis of the readjudicated data for both the first and second phases of the readjudication effort.

2.2. Analysis of first phase (mortality). This document is the SAP for the analysis of mortality (all-cause, cardiovascular, and noncardiovascular) end points assessed in the DCRI independent review and readjudication of the data from the RECORD study. It supersedes the SAP in Appendix I of Protocol AVD115170 and contains additional details of first phase analyses described in that document.

3. Objectives and operational overview

The independent data review and readjudication will be carried out in 2 phases. The first phase will consist of identification and review of all known deaths reported in the RECORD data package. The CEC will classify each death as cardiovascular, noncardiovascular, or unknown and identify the date of death. In addition, DCRI will use 1 or more algorithms to determine the date last known alive in patients not reported to have died. All persons involved in data review and adjudication will be blinded to randomized treatment arm and actual treatment administered.

In the second phase, CEC will review, based on predefined criteria, all suspected incidences of nonfatal MI or nonfatal stroke and determine whether an MI or stroke has actually occurred. For patients deemed to have had an MI or stroke, the CEC will identify the date of the event. For the end points of MI and stroke, DCRI will use 1 or more algorithms to determine the last known event-free date in patients deemed not to have experienced an MI or stroke. All persons involved in data review and adjudication will be blinded to randomized treatment arm and actual treatment administered.

Analysis of the 2 phases will be stepwise, with the mortality results being reported first. This document describes the analysis of the first phase only.

The list of deaths identified from the first phase mortality review will be compared with the list originally reported in the RECORD trial results. If the first phase, mortality review has not identified all of the deaths originally reported in the RECORD trial results, additional screening may be necessary.

Upon completion of first-phase mortality screening and adjudication, DCRI will receive electronic data containing treatment group assignment information (randomized and actual treatment administered) from GSK and perform statistical analysis of the mortality results.

Appendix Table V describes the objectives of the first phase review.

Appendix Table V. RECORD study independent readjudication objectives for the first phase: mortality

1. First phase: mortality
 - a. Without knowledge of assigned treatment arm or actual treatment administered, review data from RECORD and identify all recorded deaths
 - b. Identify causes and dates of deaths
 - c. Derive date of last survival follow-up for each patient.
 - d. Summarize source of death date*
 - e. Summarize rate and time to all-cause mortality in each of the 4 treatment groups; compare rosiglitazone (RSG) with control arms†
 - f. Summarize rate and time to CV death in each of the 4 treatment groups; compare RSG with control arms†
2. Final analysis: compare trial results based on DCRI independent readjudication with results from the original RECORD trial. Note that in this report, the comparison will be done at the summary level only and will involve neither patient-by-patient comparison nor integration of data from the original and current adjudication efforts.

*In case death dates are obtained from sources other than the CRF, such as independent third-party search.

†The primary analysis compares the RSG and SU/MET groups combined across background therapy strata.

4. Populations

All analyses will be performed on the 4447 patients included in the intent-to-treat (ITT) population in the original RECORD report.

Restriction of the analysis to a prespecified “per protocol” population (as a subset of the overall ITT population) is not intended. However, as described in Section 6, follow-up for time-to-event and event rate analyses may be limited to

specific study phases defined to reduce the potential for bias in treatment effect estimation.

5. End points

The following end points will be summarized with time-to-event and event rate per 100 patient-year analyses. Note that this SAP describes the analysis of first phase only.

First phase (mortality)

1. All-cause mortality
2. CV mortality
3. Non-CV mortality

Adjudication of deaths as CV, non-CV, or unknown cause will be done with 2 different methods, one using the original RECORD CEC definitions and one using contemporary definitions under development by FDA through the Standardized Data Collection for Cardiovascular Trials Initiative. Analyses of CV and non-CV mortality will be done for each method of adjudication.

End point status and end point dates for analyses of these end points will come from the DCRI CEC database containing the results of readjudication of identified cases. Last contact dates for vital status will be derived from the following sources:

1. RECORD database previously submitted by GSK to the FDA
2. Additional CRF data or documentation supplied to the DCRI by GSK

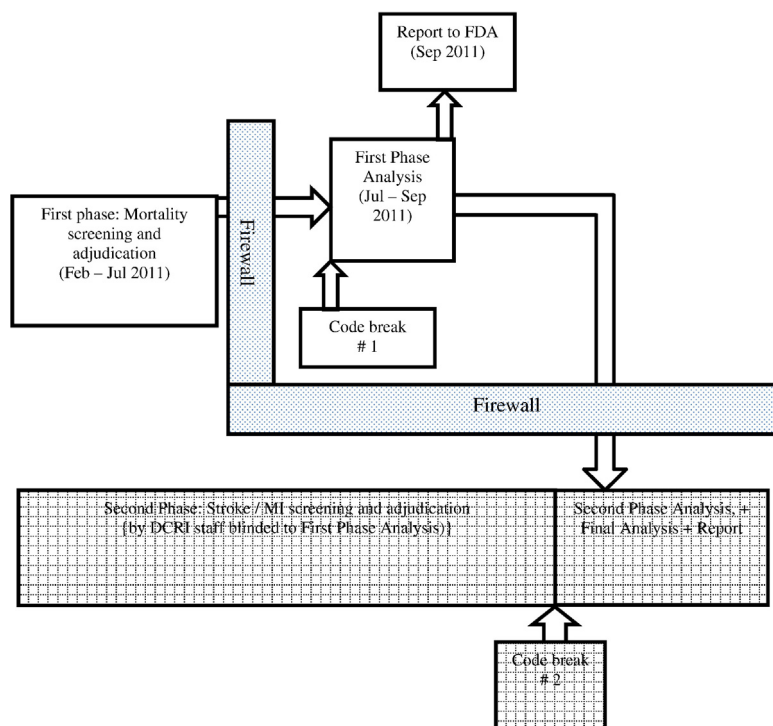

Appendix Figure 1. Timing of first and second phases. This SAP describes analyses for the first phase (mortality) only.

3. Individual patient information obtained from third party independent search, if conducted
4. Individual data received from any DCRI site queries conducted

6. Study phases and derivation of follow-up dates

6.1. Definition of study phases for mortality analysis.

The initial DCRI SAP provided a general description (Appendix I, Protocol AVD115170, Version 1.0, Section 6) of plans for derivation of randomized treatment phase (RTP), CV follow-up (CVFU), and survival status follow-up (SSFU). The CVFU phase for a study subject involved regular examinations and telephone contacts to identify CV hospitalizations and key safety and efficacy outcomes, in addition to deaths. Study subjects who wished to leave the CVFU phase had the option to participate in the SSFU phase, which would require less frequent contact and would only assess vital status.

For this report, the follow-up period for the mortality analysis is based on all available follow-up where vital status could be reliably assessed and does not depend on whether follow-up occurred more frequently, as in the CVFU, or less frequently, as in the SSFU. For this reason, end of CVFU and end of SSFU phases will not be derived for the mortality analysis.

Derivation of the RTP is described in Section 6.3.

6.2. End of survival follow-up

6.2.1. Determination of death dates. Death dates will be identified by DCRI CEC as part of the adjudication process. When there is insufficient information to allow determination of the date of death, imputation will be done as described in Section 6.2.2

6.2.2. Imputation of dates. In general, incomplete survival follow-up and death dates will be imputed to the earliest date consistent with the recorded information. For example, if the only the month and year are reported, the imputed date will be the first of the month. If only the year is reported, the imputed date will be the first of the year. In cases where the year is not recorded, no algorithm is planned, and any imputation will be done on a case-by-case basis, taking into account other available dated information for that patient.

If, by using the above algorithm, an imputed death date precedes the date last known alive, the date of death in the analysis will be the date last known alive + 1 day.

6.2.3. Parsimonious approach to end of survival follow-up. The parsimonious approach to derivation of last follow-up dates for survival will require documented face-to-face contact at study visits where 1 or more of the following parameters were recorded on the VITALS module of the CRF:

- Blood pressure (systolic or diastolic)
- Height
- Weight
- Waist circumference
- Hip circumference

The date of last follow-up for patients without a reported death will be the latest visit date where any of

the above vital signs have been recorded. Patients who are reported to have died or who have values for any of the above parameters recorded on the VITALS panel after August 24, 2008, will be considered to have completed survival follow-up (group I, Appendix Table VI).

Appendix Table VI. Determination of survival status from VITALS CRF module

Group	Description
I	Complete survival status based on reported death date or vital sign assessment after August 24, 2008
II	Incomplete survival status—patients not included in group I

Based on preliminary review of RECORD electronic databases, approximately 85% of patients are in group I. Sections 6.2.4 to 6.2.6 describe approaches to obtaining additional vital status information and deriving additional follow-up from the existing RECORD data for the patients remaining in group II.

6.2.4. Survival follow-up for primary analysis. Additional follow-up information for patients in group II (Appendix Table VI) will be used in the primary analysis of all-cause, CV, and non-CV mortality. There are 3 sources for the additional follow-up information: RECORD electronic database, independent third-party search, and DCRI internal review of CRFs and associated documentation. Use of these sources is described in Sections 6.2.4.1 to 6.2.4.3, respectively.

The date of last follow-up (for the primary analysis) for patients not reported to have died will be the latest of the dates described in Section 6.2.4.1 to 6.2.4.3. For patients who have died, the DCRI CEC will review available information to identify dates of death. In cases where the date of death cannot be determined imputation will be done as described in Section 6.2.2. All deaths occurring on or before December 31, 2008, will be included in the primary analysis.

6.2.4.1. Vital signs recorded in 2008 with last contact after August 24, 2008, by telephone visit. Patients in group II (Appendix Table VI) who had a face-to-face study visit with vital signs recorded at any time during 2008 and a telephone visit after August 24, 2008, will be considered to have complete follow-up for survival. The date of last follow-up will be date of the latest telephone visit on or before December 31, 2008.

6.2.4.2. Independent third-party search. DCRI may contract an independent third party to conduct a search for dates of follow-up or death for patients in group II (Appendix Table VI) who have limited or conflicting follow-up information available in the RECORD data. For patients shown to be alive later than the last face-to-face study visit and not reported to have died, the last observation date will be determined by the information from the third-party search. The date of last follow-up will be the latest date known alive on or before December 31, 2008. For patients known to be dead based

on the independent third-party search, the death date will be determined as described in Section 6.2.1.

6.2.4.3. DCRI internal review of CRFs and additional documentation. Dates of follow-up or death may be obtained by DCRI review of CRFs or additional study

documentation. This source includes, but is not limited to, results of an effort by GSK to confirm survival status on 437 patients withdrawn from CV follow-up and for whom survival status at study end was not obtained from a clinic visit. This effort was conducted from November 2010 to

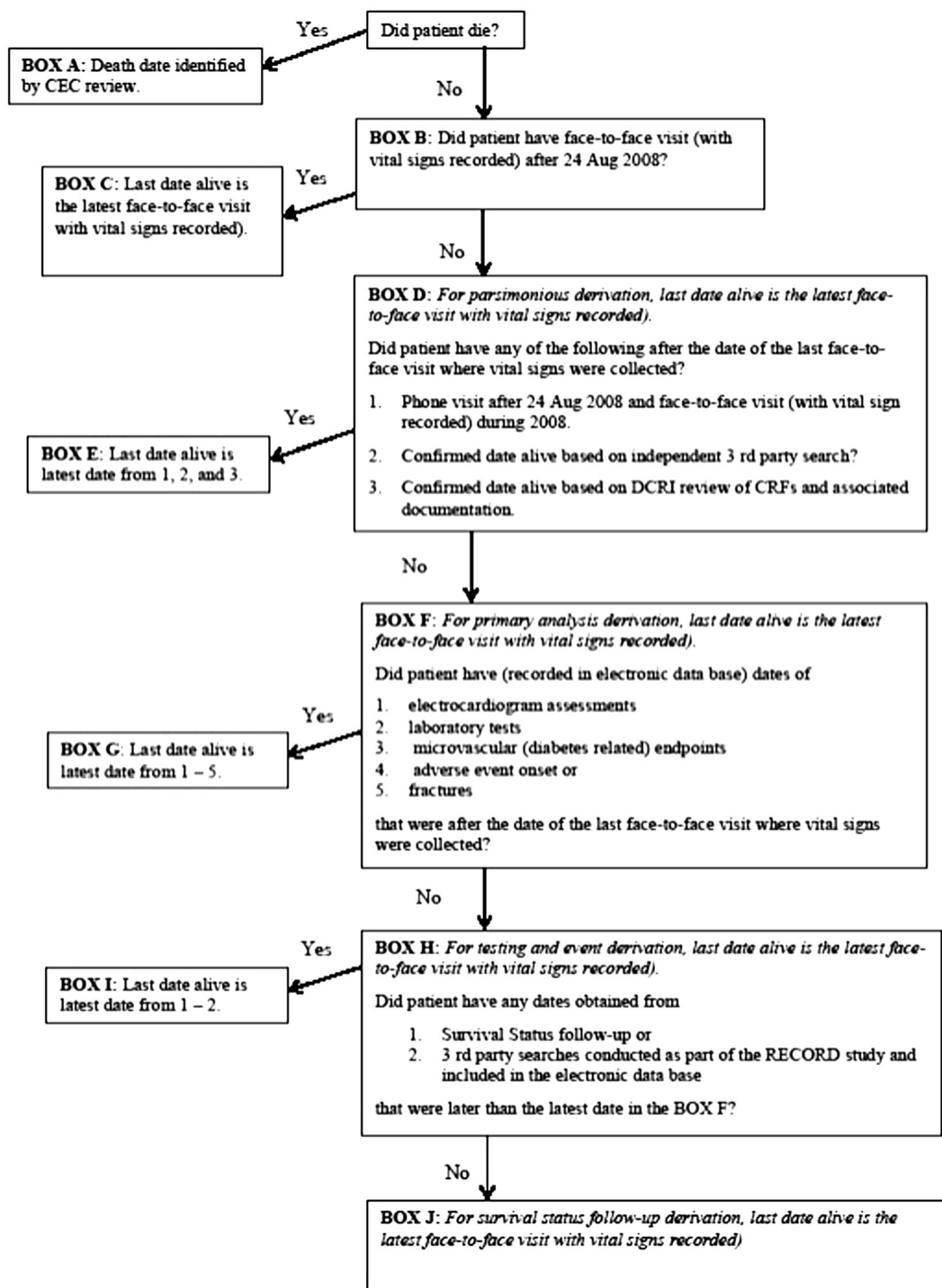

Note: Primary analysis end of observation date is described in Boxes A, C, E, and F. For patients entering Box F, the last date alive is the latest face-to-face visit where vitals were collected.

March 2011, after database finalization, and results were documented by insertion of relevant information in individual patient CRF packets. For patients shown to be alive later than the last face-to-face study visit and not reported to have died, the last observation date will be determined by the information from DCRI CRF review. The date of last follow-up will be the latest date known alive on or before December 31, 2008. For patients shown to be dead, the death date will be determined as described in Section 6.2.1.

6.2.5. Derivation of survival dates from test dates and reported patient events. The electronic database for patients with incomplete survival follow-up for the primary analysis will be screened for dates of specific patient visits or events which are later than last follow-up dates derived in Section 6.2.4. (Incomplete survival follow-up means a patient is not reported to have died, and the date last observed alive is before August 24, 2008). The modules to be screened contain dates of electrocardiogram assessments, laboratory tests, microvascular (diabetes-related) end points, AEs, and fractures. In this approach to survival follow-up, the date last observed alive is defined as the later of

- the latest onset or event date found in these modules *and*
- the date last observed alive derived using the method outlined in Section 6.2.4.

Analyses using follow-up derived from dates of electrocardiogram assessments, laboratory tests, microvascular (diabetes-related) end points, AEs, and fractures will not be considered primary and will be done only to assess the impact of incomplete follow-up documented from other sources.

6.2.6. Survival status follow-up and third-party searches within the RECORD study. For patients whose vital status after August 24, 2008, cannot be determined by the method described in Sections 6.2.3 to 6.2.5, an additional method of deriving follow-up dates for mortality analysis will use dates obtained from survival status follow-up and third-party searches conducted as part of the RECORD study and included in the electronic database. With this method, the date last observed alive will be defined as the later of

- the date last observed alive based on telephone contact with the patient, health care worker, or friend/relative/neighbor/other person or through third-party sources reported in the RECORD CRFs and
- the date last observed alive derived using the method outlined in Section 6.2.4.

If application of this method increases observed study follow-up by at least 130 patient-years, then a sensitivity analysis for all-cause and CV mortality will be done. (130 patient-years is the approximate incremental amount of

follow-up that would result in a reduction in estimated event rate of at least 0.0001, assuming 300 events and an initial value of 20,000 patient-years of follow-up.)

6.2.7. Flowchart describing derivations of end of survival follow-up.

6.3. Derivation of end dates for randomized treatment phase. The RTP is defined as the period of treatment with randomized add-on study medication (RSG, SU, or MET) and will include all visits from baseline until the earlier of study end or premature discontinuation from randomized study medication. For patients randomized to RSG, the end of RTP will be the date of last recorded dose of RSG. For patients randomized to SU/MET, the end of RTP will depend on the background therapy stratum. End of RTP for patients in the background SU group will be defined as the date of the last recorded dose of MET. End of RTP for patients in the background MET group will be defined as the date of the last recorded dose of SU.

Last date of add-on study medication may be derived from 2 different sources on the CRF. One source is the "ADD-ON STUDY MEDICATION RECORD," which records dosing of each oral therapy administered in the intervals between visits. A second source is the reported "Date of final dose of add-on study medication," which may appear in 1 of 2 places on the CRF. These are as follows:

- "Date of final dose of add-on study medication" before leaving the randomized treatment phase from the STUDY CONTINUATION/WITHDRAWAL module or
- "Date of final dose of add-on study medication" from the STUDY COMPLETION module.

The "ADD-ON STUDY MEDICATION RECORD" will serve as the primary source for deriving end of RTP. In cases where, due to missing or incomplete data, end of RTP cannot be derived from this part of the CRF, "Date of final dose of add-on study medication" will be used as the end of RTP. For patients in the ITT population who have no record of having received study drug, the end of RTP will be set to 1 day after randomization.

The end of RTP for patients who died while still receiving randomized treatment will be the CEC adjudicated date of death.

7. Analysis methods

7.1. Comparison of reported RECORD trial results and DCRI independent readjudication. Comparisons of the results from original RECORD trial results and the DCRI independent readjudication results will be done only at the summary level. Integration of the original data and the DCRI-readjudicated data for estimation of treatment effect (RSG vs control arm) is not planned for this report.

7.2. Planned analyses of end points. The objectives of the statistical analyses will be the comparison of the RSG and MET/SU treatment groups and estimation of the

treatment effect for the end points listed in Section 5. Reference date for time to event analysis will be date of randomization, with the exception of landmark analyses described in Section 7.3.4. For the end point of cardiovascular mortality, the primary analyses will classify deaths of unknown cause as cardiovascular.

For time-to-event analyses, the estimated treatment effect will be expressed in terms of the observed HR θ_{obs} ($= \lambda_{r,\text{obs}}/\lambda_{c,\text{obs}}$) and 2-sided 95% confidence limits, where λ_r and λ_c are the respective hazards for the RSG and MET/SU combination groups.

The estimate of θ for each end point will be made using a Cox proportional hazard (PH) model, stratified by background treatment (MET or SU). The HR and 95% CI and 2-sided P values for the test of a difference from the null HR of 1 will be calculated. A test for interaction between treatment group and stratum will assess the homogeneity of the treatment effect across strata. The test for interaction may be considered significant if $P \leq .10$. Secondary analyses will be done estimating θ with a Cox PH model, and 95% confidence limits, in each of the strata, MET or SU background treatment. If there is evidence of significant treatment group by stratum interaction ($P \leq .10$), the within-stratum estimates of θ may be the most relevant.

Because the DCRI independent readjudication is retrospective in nature and was not planned as part of the RECORD trial, and also involves multiple end points, study phases, and methods for deriving censoring dates, formal testing for noninferiority lacks usual controls over type I and type II error.

Unadjusted Kaplan-Meier survival curves, HRs and 95% confidence limits, and incidence rates per 100 person-years are planned for all-cause mortality, CV mortality, and non-CV mortality using the survival primary analysis follow-up derivation described in Section 6.2.4.

This SAP describes a number of time-to-event analyses, which are considered exploratory, including sensitivity analyses and subgroup analyses. These analyses will be summarized with HRs (RSG/control) and 95% confidence limits and unadjusted Kaplan-Meier survival curves. A table will be presented showing median and mean follow-up time for each end of follow-up derivation method by treatment arm (RSG vs MET/SU) overall and by stratum.

When analyses of CV or non-CV mortality are done, results will be presented separately for the 2 methods used in adjudication of cause of death (original RECORD CEC definition and contemporary definitions under development by FDA through the Standardized Data Collection for Cardiovascular Trials Initiative.)

7.3. Additional elements of the report

7.3.1. Summaries of adjudication. Descriptive statistics will summarize the results of the selection of potential end points and the adjudication results, as shown in the following bullets. Summaries will be produced by treatment arm and for the total population.

- Number of patients triggered for adjudication
- Data sources triggering cases selected for adjudication
- Number (%) of deaths classified by cause (CV death, non-CV, cause unknown) and sufficiency of information (sufficient, insufficient), as defined by the original RECORD CEC and also by contemporary definitions under development by FDA through the Standardized Data Collection for Cardiovascular Trials Initiative.

7.3.2. On-treatment analyses. Two on-treatment analyses of all-cause and CV mortality will be done, censoring patients alive on the last day of randomized treatment + 30 days, and the last day + 60 days. These analyses will be done using the survival primary analysis follow-up derivation described in Section 6.2.4, with cause of death adjudicated by the original RECORD CEC definitions and also contemporary definitions under development by FDA through the Standardized Data Collection for Cardiovascular Trials Initiative.

7.3.3. Subgroup analyses. Estimates of HRs (RSG/control) and 95% confidence limits will be computed for all-cause mortality and CV mortality for the following subgroups. No imputation will be done for subgroup variables with missing values on the electronic data sets.

- Demography
 - Sex (male, female)
 - Age in years (<60, ≥60)
- Baseline risk factors
 - Duration of diabetes in years (<6.0, ≥6.0)
 - Body mass index in kg/m² (<30.0, ≥30.0)
 - Previous ischemic heart disease (yes, no)
- Baseline CV drug use
 - Angiotensin-converting enzyme inhibitors (yes, no)
 - Statins (yes, no)
 - Nitrates (yes, no)
- By country

7.3.4. Sensitivity analyses. The following sensitivity analyses will be done to determine if the results from the DCRI independent readjudication of the RECORD trial are robust.

To assess the impact of classifying deaths of unknown cause as cardiovascular, analyses of CV mortality will be repeated, classifying deaths of unknown cause as noncardiovascular (original CEC and contemporary definitions under development by FDA through the Standardized Data Collection for Cardiovascular Trials Initiative.) This analysis will use the primary method of survival follow-up as defined in Section 6.2.4.

To assess the impact of censoring date derivation, time-to-event and event rate analyses for overall mortality and cardiovascular mortality (contemporary definitions under development by FDA through the Standardized Data Collection for Cardiovascular Trials Initiative only) under the different sets of rules for deriving study phase end

dates described in Sections 6.2.3, 6.2.5, and 6.2.6 (if follow-up is increased by at least 130 patient-years compared with the method used in Section 6.2.5) will be compared.

To assess a possible impact of Amendment 7, time-to-event and event rate analyses for overall and cardiovascular mortality (contemporary definitions under development by FDA through the Standardized Data Collection for Cardiovascular Trials Initiative only, primary method of survival status date derivation only, as in Section 6.2.4) will be compared.

- censoring all patients alive on February 27, 2006, the date of Amendment 7
- with a landmark analysis, assuming follow-up starts on February 27, 2006, and including all patients alive on that date

To assess the possible impact of a published interim report²³ of the RECORD trial, time-to-event and event rate analyses for overall and cardiovascular mortality (contemporary definitions under development by FDA through the Standardized Data Collection for Cardiovascular Trials Initiative only, primary method of survival status date derivation only, as in Section 6.2.4), will be compared.

- censoring all patients alive on June 5, 2007, the date of the interim report
- with a landmark analysis, assuming follow-up starts on June 5, 2007, and including all patients alive on that date

To assess the possibility of informative censoring, a Cox PH analysis of time-to-censoring will be done, where patients are counted as having events on the dates of censoring, whereas events are treated as “censored without event” for overall mortality and cardiovascular mortality (contemporary definitions under development by FDA through the Standardized Data Collection for Cardiovascular Trials Initiative only, primary method of survival status date derivation only, as in Section 6.2.4). A differential risk of censoring between RSG and control arms would indicate the possibility of informative censoring.

To assess the impact of selection of study cutoff date, analyses of all-cause and CV mortality will be done using August 24, 2008, as the cutoff (instead of December 31, 2008). This analysis will be done for cause of death adjudicated by contemporary definitions under development by FDA through the Standardized Data Collection for Cardiovascular Trials Initiative only, using the primary method of survival status date derivation, as in Section 6.2.4.

Appendix A: Study Phases as Defined in RECORD Reporting and Analysis Plan

From (Appendix I, Protocol AVD115170, Version 1.0, Section 6)

The DCRI independent review of data from the RECORD trial will include derivation of follow-up dates for each of the 3 study phases, defined in the RECORD Reporting and Analysis Plan (Curtis PS, Crisp A, 2009, unpublished).

- Randomized treatment phase (RTP)
- CV follow-up (CVFU)
- Survival status follow-up (SSFU).

For each patient, the last date of RTP should be no later than the last date of CVFU, which should be no later than the last date of SSFU. The following description of study phases is copied from Section 8.5 of the RECORD Reporting and Analysis Plan.

“For the management of patient disposition and withdrawals, the following definitions will be used for tracking the various mechanisms available for follow-up:

- CV follow-up phase is the entire period of follow-up for CV events and comprises the following elements:
 - Randomized treatment phase^{||} is the period of treatment with add-on study medication (RSG, SU, or MET) and will include all visits from baseline until study end, or premature discontinuation from study medication, whichever is sooner.
 - Post-randomised treatment CV follow-up phase is the period of follow-up from the time of premature discontinuation of study medication until study end, complete withdrawal, or move to survival status updates only, whichever is sooner. This phase comprises:
 - CV outcomes phase (post-randomised treatment phase);
 - Tracking substudy: post-randomised treatment follow-up for subjects withdrawn before Protocol Amendment 7.
 - Survival status follow-up is follow-up of survival status for subjects after withdrawal from CV follow-up phase.”

As noted above, the RTP may be longer in the RSG arm than in the control arm. For the purpose of identifying study phases of comparable length in the 2 treatment arms, DCRI may also consider a randomized dual-treatment phase (RDTP), provided that the RECORD database contains sufficient information to derive end of dual treatment for most patients in the trial.

^{||} Note that, according to protocol, patients in the RSG-containing arms could add a third drug (SU for patients receiving MET + RSG or MET for patients receiving SU + RSG) in case of loss of glycemic control with the dual-drug treatment and could remain on treatment. Patients in the control arm (MET + SU), however, did not have the option of the addition of a third drug, in case of loss of glycemic control with dual-drug treatment, and would be withdrawn from randomized treatment. By design, the RTP would tend to be longer in the RSG-containing arm than in the control arm.

Because the length of the RTP, CVFU, and SSFU study phases may depend on patient experiences postrandomization, other phases may also be defined with the intent of making the length of the phases independent of postrandomization experience. Rules for derivation of additional phases will be documented in an addendum to the SAP, signed before code break.

Determination of the end of study phase dates is complicated by a number of factors including

- the overall complexity of the RECORD trial
- the length of planned follow-up and usual reasons for loss to follow-up
- treatment discontinuations resulting from loss of glycemic control
- unscheduled visits at physician discretion to ensure regulation of glycemic control
- lengthening of the RTP and CVFU following Amendment 7 (February 27, 2006) to achieve median follow-up of 6 years
- multiple sources on the CRF from which to derive end of study phase dates, and
- as typical in trials with long follow-up, uncertainty of visit and contact dates resulting in incomplete date fields on the CRF.

Owing to these factors, precise determination of end of study phase dates cannot be done for all patients, and in some cases, algorithms are required to provide approximations of the length of study phases. Approximation of the length of study phases for some patients may result in error in estimates of event rates or time-to-event analyses, and because RECORD was an open-label trial, there is also a potential for bias in treatment comparisons.

In its independent evaluation, DCRI intends to use at least 2 methods for deriving end of study phase dates. The first method will use a parsimonious approach, attempting to find as simple an algorithm as possible to define study phases. With the second method, DCRI will develop a more complex algorithm, taking into account the data patterns for specific patients for whom the parsimonious approach may give clearly inaccurate or conflicting results. If deemed necessary, additional approaches may also be considered. The parsimonious approach, due to its simplicity, may have less potential for bias at the expense of reduced precision in study phase definition for some patients. During derivation of end of study phase dates, DCRI will be blinded to treatment assignment and treatment actually administered. Details of the methods used in deriving end of study phase dates will be included in an addendum to this SAP, signed before code break.

For determination of follow-up dates for analysis of mortality, we will initially consider a parsimonious approach such as the one described below. It is anticipated that this initial approach will not identify valid follow-up dates for all patients, and we expect to make appropriate modifications in an attempt to determine accurate dates for the entire study population:

End point	Event date	Censoring date
All-cause mortality	Date of death as determined by the DCRI CEC adjudication <ul style="list-style-type: none"> • Date of the last visit with documented vital signs data • Date of the patient's DCRI CEC adjudicated nonfatal CV event 	The latest of the following dates:
CV mortality	Date of death for deaths classified as cardiovascular. For patients who did not die, the latest of the following dates: <ul style="list-style-type: none"> • Date of the last visit with documented vital signs data • Date of the patient's DCRI CEC adjudicated nonfatal CV event • Date the patient withdrew from follow-up 	For patients who died of non-CV cause and did not withdraw from CV follow-up, the DCRI CEC adjudicated date of death.

Appendix F. Statistical analysis plan, DCRI independent review, and readjudication of the RECORD trial, second phase (major adverse cardiac end points)

Prepared by

Gail Hafley (Senior Statistician, DCRI)

Robert Bigelow (Associate Director of Statistics, DCRI)

January 24, 2012

Duke Clinical Research Institute

1. Abbreviations

Abbreviation	Definition
CEC	Clinical events classification
Cox PH	Cox proportional hazard (model)
CV	Cardiovascular
CVFU	Cardiovascular follow-up
DCRI	Duke Clinical Research Institute
FDA	US Food and Drug Administration
GSK	GlaxoSmithKline
MACE	Major adverse cardiac end points
MET	Metformin
MI	Myocardial infarction
RECORD	Rosiglitazone Evaluated for Cardiac Outcomes and Regulation of glycaemia in Diabetes
RSG	Rosiglitazone
SAP	Statistical analysis plan
SU	Sulphonylurea

2. Introduction

This analysis plan describes the second phase of the RECORD readjudication/reanalysis, focusing on the major adverse cardiac end points (MACE) and the components cardiovascular death, MI, and stroke. This document supplements the first-phase SAP, dated July 13, 2011, which described the methods used in the analysis of mortality. General information about the RECORD study can be found in the SAP dated July 13, 2011.

3. Objectives and operational overview

In the Re-adjudication Protocol AVD115170 for the Rosiglitazone Evaluated for Cardiovascular Outcomes and Regulation of glycaemia in Diabetes trial (RECORD) Report of the First Phase: Blinded readjudication of All-cause Mortality and Cardiovascular Mortality Final December 13, 2011, DCRI attempted to determine vital status at the end of the study for as many patients as possible, screened the data for all suspected deaths, and, for those patients determined to have died, classified the deaths according to cause (cardiovascular [CV], non-CV, or unknown). Time-to-event analyses were done for all-cause, CV, and non-CV mortality, comparing event rates in the RSG and MET/SU arms.

In the second phase, CEC will use predefined criteria to review all suspected incidences of nonfatal MI or nonfatal stroke and judge whether an MI or stroke has actually occurred. For patients deemed to have had an MI or stroke, the CEC will identify the date of the event. DCRI will use 1 or more algorithms to determine the last known event-free date in patients deemed not to have experienced an MI or stroke. All persons involved in data review and adjudication will be blinded to randomized treatment arm and actual treatment administered.

Upon completion of first-phase mortality screening and adjudication, DCRI received electronic data containing treatment group assignment information (randomized and actual treatment administered) from GSK and performed statistical analysis of the mortality results. A

lead statistician, a faculty/review statistician, a faculty cardiologist, and an editor from DCRI were unblinded to treatment group assignment and prepared the statistical analysis and study report of first-phase mortality data. The statistical analysis of second phase data will be done by separate lead and faculty/review statisticians who, during screening and adjudication of the data, have remained blinded to treatment group assignment and the results from analysis of mortality.

Appendix Table VII describes the objectives of the second phase review.

4. Populations

All analyses will be performed on the 4447 patients included in the intent-to-treat (ITT) population in the original RECORD report.

Restriction of the analysis to a prespecified “per protocol” population (as a subset of the overall ITT population) is not planned.

5. End points

5.1. Primary end points. The following end points will be summarized with time-to-event and event rate per 100 patient-year analyses. Time-to-event and event rate analyses for MI and stroke take into account only the first occurrences of these events.

Second phase (MACE)

1. First occurrence of cardiovascular (or unknown cause) mortality, nonfatal MI, or nonfatal stroke, MACE
2. MI (fatal or nonfatal)
3. Nonfatal MI
4. Stroke (fatal or nonfatal)
5. Nonfatal stroke

An MI will be classified as fatal only if it is included as a cause of death on the adjudication form. The date of the fatal MI will be the date of the most recent occurrence of an adjudicated MI within 30 days of the date of death. If there is no adjudicated MI within 30 days of the date of

Appendix Table VII. RECORD study independent readjudication objectives for the second phase: MACE

1. Second phase: MACE
 - a. Without knowledge of assigned treatment arm or actual treatment administered, review data from RECORD and identify patients with suspected MI or stroke
 - b. Adjudicate events identified in item a using same definitions as in RECORD protocol; possibly new rules for event dates*
 - c. Adjudicate events identified in item a using the FDA standardized definitions for cardiovascular trials
 - d. Derive date of last follow-up without event for patients who did not have CV death, MI, or stroke
 - e. Summarize MI and stroke (with definitions used in the original RECORD CEC effort and the readjudication effort) in each of the 4 treatment groups; compare rosiglitazone (RSG) with control arms
 - f. Summarize the combination end point of CV death, MI, or stroke (with definitions used in original RECORD CEC effort and the readjudication effort) in each of the 4 treatment groups; compare RSG with control arms
2. Final analysis: compare trial results based on DCRI independent readjudication with results from the original RECORD trial. Note that in this report, the comparison will be done at the summary level only and will involve neither patient-by-patient comparison nor integration of data from the original and current adjudication efforts.†

* The DCRI readjudication of events used the event definitions from the original RECORD study CEC. However, event dates were determined by the DCRI CEC based on the adjudicators' clinical judgment, without consideration for rules that may have been used by the original RECORD study CEC.

† Analyses of the original RECORD trial data will not be performed. However, a descriptive discussion of previously published results from the RECORD trial and the results from the DCRI independent readjudication will be included in the final study report.

death, the date of the fatal MI will be the date of death. Classification of fatal stroke will be done similarly.

The MACE composite end point (number 1 in the above list) will include any additional data on CV death obtained after the database lock for the first-phase mortality report, including identification of previously unknown deaths, new information on patient follow-up, or updated classifications of cause of death.

An updated analysis of all-cause and CV mortality may be performed if additional deaths are found that occurred on or before December 31, 2008, or information has been obtained that results in a change of event classification (eg, CV death/no CV death), or a substantial amount of additional follow-up has been obtained. In particular, events adjudicated as nonfatal MIs or nonfatal strokes for patients not reported to have died may extend the survival follow-up periods for those patients, if the events occurred after the date last reported alive in the primary analysis in the first phase report. If performed, the updated analysis of all-cause and CV mortality will use the primary method of survival defined in Section 6.2.4 of the phase I SAP, dated July 13, 2011, incorporating the additional information found.

Adjudication of the events (nonfatal MI, fatal MI, nonfatal stroke, fatal stroke, and death from CV or unknown cause) will be done with 2 different methods, one using the original RECORD CEC definitions and one using contemporary definitions under development by FDA through the Standardized Data Collection for Cardiovascular Trials Initiative. Separate analyses will be reported for each adjudication method.

5.2. Additional composite end points. The following composite end points will be summarized with time-to-event and event rate per 100 patient-year analyses. Time-to-event and event rate analyses will be based on the first occurrence of any of the events in the composite.

1. First occurrence of all-cause mortality, nonfatal MI, or nonfatal stroke
2. First occurrence of cardiovascular (or unknown cause) mortality or nonfatal MI
3. First occurrence of all-cause mortality or nonfatal MI

6. Derivation of follow-up dates

In the RECORD trial, not all patients were followed up uniformly to the end of the study (final visits to be done August 24, 2008, through December 24, 2008). The DCRI analysis considered patients whose end point status was known as of August 24, 2008, to have completed follow-up. All events occurring through December 31, 2008, were included in the primary analysis.

Derivation of the follow-up period for nonfatal MI and nonfatal stroke will be done similarly to the derivation of the parsimonious approach to survival follow-up, described in Section 6.2.3, of the first-phase SAP (July 13,

2011). If a patient is determined to have at least 1 nonfatal MI, the last follow-up date for this end point is the date of the first occurrence of the nonfatal MI, and follow-up is considered uncensored. If a patient does not have a nonfatal MI, the last follow-up date for this end point is censored at the date of the last visit at which vital signs were recorded. A similar approach is used to derive follow-up dates for nonfatal stroke. Follow-up dates for nonfatal MI and nonfatal stroke are derived independently. For example, if a patient is determined to have a nonfatal MI, the date of the nonfatal MI will not be used to derive end of follow-up for nonfatal stroke.

For patients reaching the end point of MI (fatal or nonfatal), the last follow-up date is the date of the earliest event, and follow-up is uncensored. Patients without an MI are considered to have censored follow-up at the date of the last visit at which vital signs were recorded. A similar approach is used to derive follow-up dates for stroke (fatal or nonfatal). Follow-up dates for MI and stroke are derived independently.

Last follow-up date for patients experiencing at least 1 of the MACE events will be the date of the first occurrence of any of those events. Last follow-up date for patients who did not experience any MACE event will be the date of the last study visit at which vital signs were recorded.

Because some patients did not have regularly scheduled visits with vital sign recording through the end of the study, the follow-up period may be dependent on the occurrence of an event. As a result, follow-up periods may differ from one event to another for the same patient.

7. Analysis methods

7.1. Comparison of reported RECORD trial results and DCRI independent readjudication. Comparisons of the results from the original RECORD trial and the DCRI independent readjudication will be done only at the summary level. Integration of the original data and the DCRI-readjudicated data for estimation of treatment effect (RSG vs control arm) is not planned for this report. Planning for this analysis, which involves interactions with DCRI, FDA, GSK, the RECORD Steering Committee, and the original RECORD CEC, is unlikely to be completed in time for inclusion into this report. See the DCRI Re-adjudication Protocol AVD115170 (January 28, 2011) Section 5.1, last bullet point. Additional analyses comparing patient level adjudication results from the original RECORD trial to the results of the DCRI independent readjudication may be performed at a later date and described separately.

7.2. Planned analyses of end points. The objectives of the statistical analyses will be the comparison of the RSG and MET/SU treatment groups and estimation of the treatment effect for the end points listed in Section 5. Reference date for time-to-event analysis will be date of

randomization, with the exception of landmark analyses described in Section 7.3.3. For end points of CV mortality or MACE, the primary analyses will classify deaths of unknown cause as CV.

Because the DCRI independent readjudication is retrospective in nature and was not planned as part of the RECORD trial, and also involves multiple end points, study phases, and methods for deriving censoring dates, formal testing for noninferiority lacks usual controls over type I and type II error. Estimation of the comparative cardiovascular event risk between patients receiving RSG and those receiving SU/MET is the major objective of the readjudication effort, and observed differences and confidence limits will be emphasized over nominal statistical significance inferred from P values.

Analyses described in Sections 7.2.1 and 7.2.2 will be presented separately for the 2 methods used in adjudication of MI, stroke, or cause of death (original RECORD CEC definition and contemporary definitions under development by FDA through the Standardized Data Collection for Cardiovascular Trials Initiative.)

Observed treatment differences in any of the individual components of MACE should be interpreted with caution because of the possibility of competing risks related to treatment. For example, an increase of nonfatal strokes in one treatment arm may not indicate increased risk with that arm, if more fatal strokes occurred in the other arm.

7.2.1. Primary analyses. Person-years of follow-up will be displayed for each of the end points in Section 5, by randomized treatment arm and background therapy. Person-years of follow-up will be the sum of years from randomization to event or censoring. A table will be presented showing median and mean follow-up time for each end point described in Section 5.1 by treatment arm (RSG vs MET/SU) overall and by stratum.

For time-to-event analyses, the estimated treatment effect will be expressed in terms of the observed HR j_{obs} ($= I_{r,\text{obs}}/I_{c,\text{obs}}$) and 2-sided 95% confidence limits, where I_r and I_c are the respective hazards for the RSG and MET/SU combination groups.

The estimate of j for each end point will be made using a Cox proportional hazard (PH) model, stratified by background treatment (MET or SU). The HR and 95% CI and 2-sided P values for the test of a difference from the null HR of 1 will be calculated. A test for interaction between treatment group and stratum will assess the homogeneity of the treatment effect across strata. The test for interaction may be considered significant if $P \leq .10$. Secondary analyses will be done estimating j with a Cox PH model, and 95% confidence limits, in each of the strata, MET or SU background treatment. If there is evidence of significant treatment group by stratum interaction ($P \leq .10$), the within-stratum estimates of j may be the most relevant.

Unadjusted Kaplan-Meier survival curves, HRs and 95% confidence limits, and incidence rates per 100 person-

years are planned for MI, nonfatal MI, stroke, nonfatal stroke, and MACE using the follow-up derivation described in Section 6. Updated analyses of all-cause mortality and CV (including unknown cause) mortality may be done if additional death or follow-up information has become available since the completion of the first-phase mortality report (December 13, 2011.)

7.2.2. Summaries of adjudication. Descriptive statistics will summarize the results of the selection of potential end points and the adjudication results, as shown in the following bullets. Summaries will be produced by treatment arm and for the total population.

- Number of patients triggered for adjudication
- Data sources triggering cases selected for adjudication
- Number (%) of events classified by sufficiency of information (sufficient, insufficient), as defined by the original RECORD CEC and also by contemporary definitions under development by FDA through the Standardized Data Collection for Cardiovascular Trials Initiative

7.3. Additional elements of the report. This section describes time-to-event analyses, which are considered exploratory, including sensitivity analyses and subgroup analyses. These analyses will be summarized with HRs (RSG/control) and 95% confidence limits and unadjusted Kaplan-Meier survival curves.

The analyses described in Section 7.3 are planned for events adjudicated by the New (Standardized Data Collection for Cardiovascular Trials Initiative) method only. If the primary analysis shows qualitatively different results between the New definitions and the Original definitions (used in the original RECORD trial) for an end point, the analyses described below may also be conducted with events adjudicated by the Original definitions. A preliminary definition for “qualitatively different” is a relative difference of 10% or greater in the HRs obtained between the 2 methods of adjudication. This definition is intended to be used as a guide and will not necessarily be strictly applied. Other criteria, such as clinical relevance of a particular result, may be used to decide whether to produce analyses for events adjudicated by the Original definitions.

Analyses described in Section 7.3 use follow-up derivations described in Section 6.

7.3.1. On-treatment analyses. Two on-treatment analyses of the end points described in Section 5.1 will be done, censoring patients alive on the last day of randomized treatment + 30 days, and the last day + 60 days.

7.3.2. Subgroup analyses. Estimates of HRs (RSG/control) and 95% confidence limits will be computed for MI (fatal or nonfatal), Stroke (fatal or nonfatal), and MACE for the subgroups defined below. No imputation will be done for subgroup variables with missing values on the electronic data sets.

- Demography
 - Sex (male, female)
 - Age in years (<60, ≥60)
- Baseline risk factors
 - Duration of Diabetes in years (<6.0, ≥6.0)
 - Body mass index in kg/m² (<30.0, ≥30.0)
 - Previous ischemic heart disease (yes, no)
 - Baseline glycated hemoglobin (<7.4%, 7.4%–<7.8%, 7.8%–<8.4%, ≥8.4%)
- Baseline CV drug use
 - Angiotensin-converting enzyme inhibitors (yes, no)
 - Statins (yes, no)
 - Nitrates (yes, no)
 - β-Blockers (yes, no)
- By country

7.3.3. *Sensitivity analyses.* The following sensitivity analyses will be done to determine if the results from the DCRI independent readjudication of the RECORD trial are robust.

To assess the impact of classifying deaths of unknown cause as cardiovascular, analyses of MACE will be repeated classifying deaths of unknown cause as non-CV.

To assess the impact of insufficient information available for assessing whether or not an event occurred, analyses of MI, stroke, and MACE will be repeated classifying events with insufficient information as nonevents.

To assess possible impact of Amendment 7, time-to-event and event rate analyses for MI, stroke, and MACE will be compared:

- censoring all patients without event on February 27, 2006, the date of amendment 7
- with a landmark analysis, assuming follow-up starts on February 27, 2006, and including all patients who have not had an event before that date

To assess the possible impact of a published interim report²³ of the RECORD trial, time-to-event and event rate analyses for MI, stroke, and MACE, will be compared:

- censoring all patients without event on June 5, 2007, the date of the interim report
- with a landmark analysis, assuming follow-up starts on June 7, 2007, and including all patients who have not had an event before that date

To assess the possibility of informative censoring, a Cox PH analysis of time-to-censoring, where patients are counted as having events on the dates of censoring, will be done, whereas events are treated as “censored without event” for MI, stroke, and MACE. A differential risk of censoring between RSG and control arms would indicate the possibility of informative censoring.

To assess the impact of selection of study cutoff date, time-to-event analyses of MI, stroke, and MACE will be done using August 24, 2008 as the cutoff (instead of December 31, 2008).

Other sensitivity analyses that will be considered include the following:

To examine the effect of a potential difference in follow-up periods among the end points of MI, stroke, and CV death, an analysis of MACE will be done taking into account interval censoring. In this analysis, major cardiovascular events determined by the occurrence of a CV or unknown cause of death after the date of the last face-to-face visit will be considered subject to interval censoring, and the HR between RSG and control arms will be estimated using the Weibull model, as described in Lindsey and Ryan.²⁴ In this analysis, the date of the MACE event will not be the date of the CV or unknown cause death; rather, it will be considered to occur between the date of the last face-to-face visit and the date of death, during a period when a nonfatal MI or stroke could have occurred without being reported. This analysis will use SAS PROC LIFEREG, and the model statement will be expressed as “MODEL (LOWER, UPPER) = {treatment arm indicator}/dist = weibull,” where

- For patients who do not have an MI, stroke, or CV or unknown cause death
 - LOWER = date of last face-to-face visit
 - UPPER = missing
- For patients who have MACE determined by MI or stroke
 - LOWER = date of event
 - UPPER = date of event
- For patients who have MACE determined by CV or unknown cause death
 - LOWER = date of last face-to-face visit
 - UPPER = date of death

Because not all patients were followed up uniformly to the end of the RECORD trial, estimates of the amount of unobserved follow-up will be made, and the potential impact on MACE will be assessed. Unobserved follow-up will be calculated as the sum of time from the last visit at which vital signs were recorded to August 24, 2008, for patients who did not have MACE. (Note that patients who were followed up to August 24, 2008, would be considered to have completed the study follow-up.) Patients who had MACE would be considered to have no unobserved follow-up. We will simulate the occurrence of events between the date last observed without event and December 31, 2008, for patients who did not have MACE and were not followed up to August 24, 2008. For each simulation run, the HR will be estimated from a data set containing the observed and simulated data. The distribution of the simulated outcomes will be described. The simulations will be done for a variety of assumed HRs, including the estimated HR from available data as well as HRs adverse to RSG (25%, 50%, 75%, and 100% increased risk).

To obtain an estimate of the HR accounting for baseline characteristics, a Cox PH model for the end points of MI, stroke, and MACE will be generated adjusting for variables described in Section 7.3.2 and possibly other clinically relevant baseline factors.