

Accepted Manuscript

Title: Energy retrofit and occupant behaviour in protected housing: A case study of the Brunswick Centre in London

Author: Hui Ben Koen Steemers

PII: S0378-7788(14)00411-3

DOI: <http://dx.doi.org/doi:10.1016/j.enbuild.2014.05.019>

Reference: ENB 5055

To appear in: *ENB*

Received date: 13-9-2013

Revised date: 9-5-2014

Accepted date: 14-5-2014

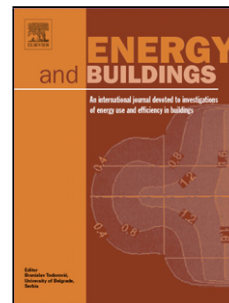

Please cite this article as: H. Ben, K. Steemers, Energy retrofit and occupant behaviour in protected housing: A case study of the Brunswick Centre in London, *Energy and Buildings* (2014), <http://dx.doi.org/10.1016/j.enbuild.2014.05.019>

This is a PDF file of an unedited manuscript that has been accepted for publication. As a service to our customers we are providing this early version of the manuscript. The manuscript will undergo copyediting, typesetting, and review of the resulting proof before it is published in its final form. Please note that during the production process errors may be discovered which could affect the content, and all legal disclaimers that apply to the journal pertain.

Highlights:

- Behaviour change has the highest energy-saving potential in listed housing retrofit.
- The impact of behaviour change can range up to 62% to 86% of the total energy saving.
- The lower behaviour change effect is associated with a higher retrofit level.
- Heating temperature has the highest impact on energy use amongst behaviour variables.

Title: Energy retrofit and occupant behaviour in protected housing: A case study of the Brunswick Centre in London

List of authors:

Hui Ben*, Department of Architecture, University of Cambridge, 1-5 Scroope Terrace, Cambridge CB2 1PX, UK, Tel: +44 (0) 1223 332989; Fax: +44 (0) 1223 332960. Email: hb403@cam.ac.uk

Professor Koen Steemers, Department of Architecture, University of Cambridge, 1-5 Scroope Terrace, Cambridge CB2 1PX, UK, Tel: +44 (0) 1223 760111; Fax: +44 (0) 1223 332960. Email: kas11@cam.ac.uk

Abstract:

This study examines the impact of behavioural and physical variables on the energy saving from retrofitting protected housing. Protected housing in England is referred to as 'listed' housing managed by English Heritage. The result of the study demonstrates that balanced approaches can be developed to retrofit listed housing by taking into account occupant behaviour factors, to meet the requirement of both energy efficiency and heritage conservation. A case study of the Brunswick Centre in London shows that the highest household energy use can be 2.2 times higher than average consumption. According to the modelling results from Integrated Environmental Solutions (IES) software, the impact of positive behavioural change ranges up to 62% to 86% of the total potential savings in the tested dwellings, where the lower behaviour change effect is associated with a higher retrofit level. However, rebound behaviour could offset estimated energy saving from physical improvement. Based on the findings, a framework of intervention measures is developed, which demonstrates that the proportion for behavioural change and building technology varies with respect to household energy use level. In summary, this study shows that in listed housing behavioural change has the potential to bring substantial energy saving far exceeding that from physical improvements, and thus tackling behavioural change plays a pivotal role in developing integrative strategies for listed housing retrofit.

Keywords: Energy retrofit; Occupant behaviour; Protected/ Listed housing; Energy modelling; Potential energy saving

1. Introduction

“Listed buildings are those included on the statutory List of Buildings of Special Architectural or Historic Interest. Controls apply and Listed Building Consent is required for any works of alteration or extension – both external and internal – which would affect a building’s character.” [1]

Improving the energy efficiency in the domestic housing stock is a key priority to the success of achieving national carbon emissions reductions such as the UK Government’s target to tackle climate change [2,3]. The UK aims to reduce its greenhouse gas emissions by 80% by 2050. The residential sector accounts for 27% of total CO₂ emissions, which is therefore one of the most important sectors to address [4]. It is estimated that about 75% of the existing housing stock in the UK will still be in use by 2050 [5]. Consequently, retrofitting existing housing to become more energy efficient is critical to reduce energy consumption. Listed housing represents the finest building stock among existing housing, where retrofit intervention should balance historic value and energy efficiency [1,6,7].

In the context of improving energy efficiency in listed housing, this paper examines ways to enhance the potential energy savings from retrofits. However, the energy savings that are realised in practice often fall short of expectation. One explanation is that improvements in energy efficiency encourage greater expectations of the energy-related services such as thermal comfort. Behavioural responses such as these have come to be known as the rebound effect [8]. While this effect may be sufficiently large to lead to zero (or even less than zero) energy savings, an outcome that has been termed ‘backfire’, positive behavioural changes may increase energy savings following retrofit, known as ‘green behaviour’.

Occupant behaviour plays a major role in determining building energy use according to existing literature [9-19]. It is usually the main reason causing the significant gaps between actual and predicted energy performance of buildings [10,20,21]. Studies have shown that occupant behaviour may vary to such an extent that the resultant building energy use differs by a factor of two or more [22,23].

Studies carried out for energy retrofit of heritage buildings have mainly concentrated on technical improvements [1,6,24-31]. The extent to which these improvements can actually achieve energy savings, taking into account possible behavioural change, has rarely been explored to any great extent in an integrated manner. The lack of assessment of such behavioural impact calls for further investigation with respect to a balanced approach for heritage conservation and energy efficiency.

This paper aims to reveal to what extent occupant behaviour has an impact on the energy saving from listed housing retrofit, seeking to improve energy efficiency potential by taking behaviour change into account. Given the constraints on physical interventions into the fabric of listed buildings, the hypothesis is that in the retrofit of listed housing, if occupant behaviour changes are fully realised, then substantial energy savings can be achieved from the improvement that addresses both historic conservation and energy efficiency.

2. Background information of listed housing case study

The Brunswick Centre in London has been chosen as the case study for listed housing. This residential complex is a notable post-war housing scheme praised for its high-density low-rise design and mixed-use development. The building was designed by Patrick Hodgkinson in 1967, listed 'Grade II' by English Heritage in 2000, and renovated by Levitt Bernstein in 2005-6. Its aim was to create an exemplary urban environment where everyone was brought together without social segregation. As a concrete 'mega-structure' social housing scheme,

the Brunswick contains 407 flats with a shopping centre on the ground floor and car parking below. All the flats are served by a gas-fired district-heating system.

The Brunswick building contains four types of dwellings, including bedsits, one-bedroom flats, two-bedroom flats, and maisonettes. Two-bedroom flats are found to be the most common type (see Section 3, baseline model), accounting for approximately half of the total dwellings. In each of these wide-frontage single-aspect flats, the living room extends to a winter garden and connects to the kitchen space as a whole. In this way, daylight can reach deeply into the dwellings, especially with the raked section of roof glazing that helps with increasing light angles. In addition, both living room and bedrooms intercommunicate but are insulated from access corridors by service rooms. Due to the setback at each floor level, there is an external strip of exposed floor along the back of each flat.

3. Research methodology

The specific purpose of this section is to provide a basis for carrying out more detailed study on assessing the impact of occupant behaviour on the overall energy saving in listed housing. This section presents the development of the Retrofit Model Framework (RMF) (Fig.1), which provides a structure for modelling energy use from domestic retrofit at individual dwelling level, while assessing the potential impact of occupant behaviour on the energy saving. It is a bottom-up physical model, based on building physics equations and algorithms, taking different sets of scenarios into account that influence the retrofit energy saving. For the physical modelling we use the validated energy simulation tool, IESVE [32]. This approach provides a sufficient degree of flexibility and capability in modelling occupant behaviour and testing scenarios related to changes in both physical and behavioural parameters.

3.1. Input parameters

A baseline dwelling model (Fig.2) has been adopted for the purpose of standardisation, to allow various parameters to be meaningfully compared. It is characterised by being a west facing mid floor two-bedroom flat at the Brunswick Centre. The source for the climatic condition and site data was the IES ASHRAE [32] weather database for London. The input parameters of building construction profiles for the base case are shown in Table 1. The flat height is measured as 2.7m, with a width of 9.6m and a depth of 9.0m (including winter garden). Standardised input behavioural parameters have been extracted from existing models and literature (Table 2). The rest of input parameters that are unavailable from the surveys carried out have been obtained from IES default data [32] or published data (ASHRAE and CIBSE Guide) (Table 3).

3.2. Calibration of baseline model

The survey at Brunswick shows the annual bill for heating is £866.81 per flat in 2012/13 [33]. This represents the average heating cost of the base case flat. In order to estimate the heating energy consumption, we use gas unit rate at 4.37 p/kWh (this figure is taken from British Gas online tariff rates, under the category of postcode WC1N 1QF and Direct Debit payment). By dividing the annual consumption by the floor area of the base case (70.68m²), the gas usage is estimated as 280kWh/m²y that is used as the figure for calibration of the model.

The electricity bill varies among different households at Brunswick. In order to assign an average value for the base case model, we assume the standard yearly bill is £481 with unit rate at 12.796 p/kWh (British Gas online tariff rates). Thus the calculated electricity usage for an average energy user at Brunswick is 53 kWh/m²y.

Using the energy consumption data analysed above, the baseline model can be calibrated through adjusting the values of physical and behavioural parameters (Fig.3). Firstly, we assign the values of input parameters specified in section 2.1 to the model. The calculated energy use is 286.8kWh/m²y, of which heating use is 231.7kWh/m²y and electricity use is 55.1kWh/m²y. The first estimation is reassuringly (-14%) close to the real data, especially in the context of the assumption chosen for heating set temperature. Heating temperature is one of the most important behavioural parameters to calibrate the results [33]. For heating energy use, we adjust the heating temperature for 'active hours' to 21°C for the whole flat instead of only for the living room (no radiator in kitchen), with the rest of the settings remaining unchanged (Table 4). This is justified by the monitoring results and due to the fact that heating energy is charged at a flat rate for all dwellings (i.e. there is no incentive to reduce the set temperature). The resulting model output energy use is 334.7kWh/m²y, of which heating use is 279.6kWh/m²y and electricity is 55.1kWh/m²y. These values are sufficiently (0.5%) close to the actual figures to provide reassurance that the model is sufficiently calibrated for testing scenarios. This is used as the 'base case' in the subsequent analysis.

3.3. Explorative scenarios

The main step of the Retrofit Model Framework seeks to explore occupant behaviour effects in IES modelling with respect to the energy savings for different retrofit levels. This is a modelling exercise where scenarios are created by adjusting physical variables, behavioural variables, and mixed variables (detailed in Section 5). It tests possible physical and behavioural effects on the effectiveness of retrofit interventions and resulting energy saving variations. In addition, as part of the research, sensitivity analysis of both physical and behavioural parameters will be explored to test their respective impacts on energy demand.

4. Case study - the Brunswick Centre in London

Post occupancy evaluation and monitoring have been carried out at the Brunswick Centre in London to collect physical building and occupational data, as well as to examine occupants' perceptions towards energy use and efficiency improvements. It utilizes triangular data collection techniques, including overt non-participation observations, logger data-monitoring, and semi-structured interviews with questionnaire surveys. The aims are to obtain the information required for energy modelling, and to bridge the gap in input assumptions between building parameters and end-users.

4.1. Energy use estimation

Based on physical and occupancy surveys, modelled energy use of the surveyed flats is shown in Table 5. Three main behavioural parameters are identified and tested in the model, including heating temperature, heating schedule, and window opening schedule. In addition, occupancy number and flat orientation, that influence the internal gains and solar radiations of the flats, are included. By comparing energy use and behaviour patterns, their interrelationship can be further analysed.

4.2. Comparison of energy consumption

Table 6 and Fig.4 provide a comparison of the calculated energy uses of the surveyed flats at Brunswick with data from Morgenstern [34], which indicates that household energy use can vary by between 2 and 3 times, due to different behaviour patterns and calculation assumptions. For example, the highest energy user (flat B) is about 2.2 times as high as the base case and 2.5 times as high as the SAP estimation. In addition, the SAP result is 14% lower than the base case, which potentially means the assumptions made in SAP may lead to an underestimation of the actual performance in this context (i.e. due to fixed energy bills and a poorly insulated building).

The increase of heating energy as a consequence of increasing set-point temperature is predictable, despite the fact that other variables are different (Fig.5). The chart shows that energy use increases faster as the temperature goes higher. The different percentages of energy increase per 1°C set-point increase are explained by the differences in the other factors, such as occupancy schedules, orientation, ventilation, etc. These factors have different sensitivities with respect to energy use, and thus have different impacts on energy demand.

The potential impact of orientation is presented by modelling each surveyed flat with two orientations (West and East facing; N.B. There are no South and North facing flats at the Brunswick). The results show that the variance resulting from the comparison of West and East orientation ranges from 0.23% to 0.97%, with east facing flats having marginally higher energy use. This might be due to different effects of solar radiation on different orientations. By quantifying this impact of orientation, the relative effects of behavioural variables on energy use can be compared in the Brunswick flats.

5. Retrofit application

5.1. Retrofit Strategies for the Brunswick Centre

The retrofit strategies developed for Brunswick are grouped into three categories: (a) building fabric, (b) building system, (c) in-home displays. For each category there are alternative improvement measures as a part of an overall retrofit plan, that are constrained by the fact that they must be compatible with listed building status (see below). This assessment mainly tackles the energy reduction on the demand side; renewable and low carbon technologies for the supply side are not included in this study.

5.1.1. Building Fabric

As a Grade II listed building, the Brunswick has relatively limited options for improving its building fabric, due to building regulation and planning controls. Fabric performance is fundamental to achieving significantly reduced energy consumption while maintaining acceptable levels of thermal comfort [35]. However, some measures are generally not considered appropriate for listed building, such as external wall insulation and double (or triple) glazing. Based on the building performance evaluation of Brunswick shown in the previous section, we develop several viable improvement strategies for its fabric, including cavity wall insulation, roof insulation, secondary glazing, and draughtproofing. These retrofit strategies are all within generally accepted criteria for listed building consent. Each measure is assessed in the following tables 7 and 8.

Table 8 shows that wall insulation, and draughtproofing are the most cost-effective measures for building fabric improvement. However, it should be noted that the calculations of energy use and saving are based on the Brunswick flat, and the generic capital cost and payback period of the measures referred to in Table 7 are subject to change according to different projects. Nevertheless, draughtproofing appears to be the best option in terms of disruptiveness and cost-effectiveness.

5.1.2. Building system

The results in Table 9 and 10 show that insulation of hot water cylinder and pipework is more cost-effective than boiler upgrade in improving building systems at Brunswick. However, boiler upgrade brings more than twice as much the energy saving as insulation of hot water cylinder and pipework in each flat. In addition, the central boiler upgrade in Brunswick brings energy savings to 407 flats due to its district heating system. Thus, when considering

improving building systems, the balance between installation cost and energy saving needs to be considered in the specific context.

5.1.3. In-home displays

In-home displays could help occupants save energy by revealing information about the use of energy services in homes and induce subsequent behaviour change. Energy data can be measured and displayed, and this should encourage occupants to see which items use the most energy and learn to use energy more efficiently [40]. Currently tenants at Brunswick have no control over their heating energy bills as they pay a fixed charge according to floor area. However, some households (i.e. flat B and D) consume much more energy than the average rate, and all the participants have only a vague idea of how much heating energy they use for different purposes. Thus, by installing heat and electricity meters, householders could be charged according to their actual consumption and have the financial drivers to behave more energy efficiently. This strategy of individual metering coupled with in-home displays is designed to address behavioural change instead of fabric improvement. The direct effect of displays is not assessed here but it is assumed that behaviour changes outlined in Section 5.2 could be driven by such feedback.

5.1.4. Retrofit levels

Based on the proposed improvement measures outlined above, we categorise retrofit strategies into three levels according to their capital costs and payback periods: 'Min-retrofit', 'Med-retrofit', and 'Max-retrofit'. Table 11 provides detailed calculation of energy use and saving for each retrofit level.

5.2. Occupant behaviour

This section presents an analysis of behavioural parameters regarding their different levels of impact on household energy consumption. Any behavioural change is likely to have a relative impact for different levels of retrofit. In order to map out the possible energy effects of behavioural variables following retrofit interventions, we group them into three categories: low-energy, medium-energy, and high-energy behaviour. This analysis uses the base case flat (mid-floor, two-bedroom, west-facing), following different levels of physical improvements. Each behaviour level is described below.

5.2.1. Low-energy behaviour

The low-energy behaviour scenario represents a combination of the lowest ‘reasonable’ behavioural variables that are based on survey data. These include a heating set temperature of 18°C, with a heating schedule of 7am-9am/4pm-11pm weekdays and 7am-11pm weekends, and no window opening. The results of modelling a low-energy behaviour scenario in Table 12 show that the energy use and savings at each retrofit level are significantly lower than that of a med-energy behaviour base-case scenario, with percentage reductions ranging from 7 to 27%. This means that with low-energy behaviour the effect of physical improvement is small in terms of absolute energy use, and the payback periods may be too long to be considered financially acceptable.

5.2.2. Medium-energy behaviour

The energy use and saving with medium-energy behaviour at different retrofit levels are shown in Table 11. A medium-energy behaviour scenario represents a combination of the standardised behavioural variables based on existing literature [41-45]. These include heating set temperature of 21°C, a heating schedule: 7am-9am/4pm-11pm weekdays and 7am-11pm weekends, heating temperature at 15°C for the rest of the time, and window opening 7am-

9am (window being kept open from 7am to 9am). The results of modelling a medium-energy behaviour scenario show a decrease in absolute energy use as the retrofit level increases, and energy saving from different retrofit levels ranges from 9 – 30%. This means physical improvements in a medium-energy behaviour scenario can be effective in terms of energy saving, and they may thus have a shorter payback period than that in a low-energy behaviour scenario.

5.2.3. High-energy behaviour

A high-energy behaviour scenario represents a combination of the highest ‘reasonable’ behaviour variables based on the monitoring surveys. These include a heating set temperature of 24°C, a heating schedule 24 hours for living room and bedrooms, and window opening 24 hours. The results of modelling the high-energy behaviour scenario show the energy use after retrofit is still comparatively high no matter at which level, though the absolute energy savings from different retrofit levels range from 10 – 30%. This means physical improvement in a high-energy behaviour scenario can reduce energy use slightly more significantly, yet even with the deepest retrofit the overall consumption is still almost 2.5 times as high as a low-energy behaviour scenario without retrofit.

5.2.4. Comparison of behavioural scenarios

Theoretical estimation indicates significant behavioural impact on energy use and savings from retrofit (Fig.6-8). The behavioural impact (high-e to low-e) on energy saving is approximately 62%, 71%, and 86% at max-, med-, and min-retrofit level respectively. If the occupant behaviour shifts from a high-e to a low-e scenario in the base case, the absolute energy saving from this behavioural change could be 5.5 times greater than that from maximum retrofit under a medium behaviour scenario. Meanwhile, if occupant behaviour

changes in the opposite direction (from low/med to high) and increases energy use, it could change to such an extent that offsets the energy saving from physical improvement at any retrofit level. In this case, the ‘backfire’ effect can occur at any point between min-retrofit and max-retrofit, which means 100% rebound (zero energy saving due to behavioural change) can be found at any retrofit level if behaviour change from low/med-e to high-e scenario.

5.3. Sensitivity Analysis

Sensitivity analysis is the study of how the variation in the output of a model depends upon the input information [46]. As physical improvements are constrained due to ‘listed building’ status, this section applies the sensitivity approach to further cross-evaluate the impact of behavioural changes upon physical improvements regarding listed housing performance and subsequent energy savings. It also examines the relative impact of each physical or behavioural parameter on energy use with the one-factor-at-a-time method. Following suggestions from the literature, the finite-difference approximation approach is adopted and an increment of $\pm 1\%$ change is used [47,48]. In this approach the base case model is important for assigning nominal input values.

A three-step calculation of parametric sensitivity is presented, including physical improvements, behavioural changes, and mixed variables. The first step determines the impact of each retrofit measure on energy consumption using standard behavioural assumptions without taking any behavioural change into account. Then we isolate behavioural parameters to quantify their impacts on energy use on the pre-retrofit base case. Finally, the sensitivity of each behavioural parameter is tested on three retrofit levels (min-retrofit, med-retrofit, and max-retrofit).

5.3.1. Physical improvements

The sensitivity analysis of physical parameters shows the effect of each improvement measure on energy use in the base case flat. The simulation runs with standardised occupancy settings equal to medium-energy behaviour scenario. All parameters show linear sensitivity for the ranges of the tests. The results show that seasonal efficiency of the heating system has the highest sensitivity of 0.75% in negative value. This means theoretically a 1% increase in the seasonal efficiency will lead to a 0.75% decrease in energy use. In our analysis, the sensitivity of each parameter is subject to the physical conditions of the base case, such as the cavity wall area ratio, single glazed window area ratio, and the number of windows and doors where draughtproofing for infiltration is needed. These fixed conditions will have an effect on overall sensitivity of each parameter tested, which may lead to different results comparing with other studies (i.e. Murray and O’Sullivan [49]). Nevertheless, it provides a general indication on the potential range of impact from these retrofit measures on energy use.

5.3.2. Behavioural changes

A nominal value of set-point temperature has been assigned based on the average value between low-energy behaviour and high-energy behaviour. The nominal value of heating and window opening length have been set as 10 hours (9pm-7am and 9am-7pm respectively) for percentage calculation purpose (i.e. 10% equals 1 hour); and we assume living room and bedrooms have the same schedule. When testing each behavioural parameter, the rest are based on the conditions before retrofit with the medium-energy behaviour scenario (for the heating length test, the temperature is set to be 21°C constantly).

In the sensitivity analysis of the heating length, we increase the length by extending the heating time in the evening (i.e. 1 hour increase: changing from 9pm to 8pm); and shorten the length by changing the time in the morning (i.e. 1 hour decrease: changing from 7am to 6am).

Similarly, in the sensitivity analysis of window opening length, we increase the length by extending or shortening the time from 7pm (i.e. 1 hour increase or decrease: changing from 7pm to 8pm or 6pm).

The sensitivity analysis of behavioural parameters shows the impact of occupant behaviour on energy use in the base case flat. The simulation results are shown in Table 15, and all the behavioural parameters have nonlinear sensitivities. The heating temperature has the highest sensitivity of 3%-5%, which means theoretically a 1% increase in heating temperature will lead to a 3%-5% increase in energy use. In other words, 1% increase in temperature setting (i.e. 4% energy increase) could approximately offset energy saving from 5% increase in boiler upgrade (i.e. $5 \times 0.75\%$) or 7% increase in pipe insulation (i.e. $7 \times 0.6\%$), with the rest of physical measures ineffective by comparison. From this analysis, we can see the change in heating temperature would easily change overall energy consumption no matter what physical improvements have been installed. Therefore, in order to effectively reduce the energy use in the Brunswick flats, priority should be given to the heating temperature control.

5.3.3. Mixed variables

Further sensitivity analyses of behavioural parameters on min- and max-retrofit levels have been carried out, aiming to test how the effects of behavioural parameters may change under different building efficiency parameters [33]. The results (not presented here in detail) show that the sensitivity of behavioural parameters at different levels of retrofit remains approximately the same, of which heating temperature and window opening length parameters have increased slightly (within 0.36% and 0.01% respectively), whereas the sensitivity of heating length parameter has a slight decrease up to 0.07%. This implies that with deeper retrofit, the effect of heating temperature and window opening length may be reduced, while the effect of heating length may be raised. Nevertheless, the change in the

sensitivity of these parameters from different retrofit levels is trivially small, and the overall impact of behavioural variables on energy use remains relatively constant.

6. Discussion

This study illustrates the energy effects of occupant behaviour on the energy efficiency potential from retrofitting listed housing, using a case study and modelling analyses. We demonstrate the importance of taking into account behavioural factors for better approaches to improve the performance of heritage buildings. The application of physical improvements often leads to a discrepancy between predicted and actual energy saving partly due to behavioural factors. This provides motivation to model behavioural variables explicitly to quantify the impact of occupant behaviour on energy saving potential in listed housing retrofit.

It is shown that changing occupant behaviour has the potential to reduce the energy consumption of Brunswick flats by more than one half. According to the estimated energy uses of surveyed flats at Brunswick, the highest household energy use can be about 2.2 times higher than average energy use of the building. In other words, if the highest energy users change the behaviour patterns and reduce energy uses, their energy savings could reach more than 50% of the current consumption.

The theoretical investigation on retrofit application shows that behavioural change has a significantly higher impact on energy saving than physical improvement. This behavioural impact is two-sided. On the one hand, if 'rebound' behaviour occurs (from low/med-e to high-e) that increases energy use, it could offset energy saving from physical improvement and even lead to 'backfire' at any retrofit level. On the other hand, if conservation behaviour is induced (from high-e to low-e), it can reduce energy use substantially irrespective of physical improvement.

The findings of behavioural impact on the energy saving suggest a range up to 62% to 86% depending on retrofit levels, and this impact decreases as the retrofit level increases. Explorative scenarios on physical improvement and behavioural change show that different levels of energy use behaviour require different approaches to reduce energy consumption. The modelling results indicate that at a high-energy behaviour level, the energy saving potential from changing to conservation behaviour (high-e to low-e) could be significantly higher than that from physical improvement; at a low-energy behaviour level, physical improvement is the most effective way of saving energy. A better understanding of retrofit strategies and occupant behaviour change in general will help to improve energy saving in practice.

Sensitivity analyses of various physical and behavioural variables demonstrate that heating temperature has the highest impact on energy use among all the tested parameters. This means tackling the control of heating temperature would be the most effective way to reduce energy use. Further sensitivity analyses of behavioural variables at different levels of retrofit reveal that slight changes occur within trivially small ranges, which means that the energy effects of behavioural variables generally remain constant regardless of retrofit levels.

The analysis of behavioural impact on the energy saving implies that balanced approaches for listed housing retrofit closely link with energy use behaviour. The level of energy use behaviour dictates intervention measures for listed housing, along with the performance of building fabric and system. Balanced approaches could be developed based on occupants' energy use levels and characteristics. For example, the measures to improve low-level energy users' homes are likely to focus on physical improvement, whereas the main emphasis could be given to conservation behavioural change when expecting to achieve substantial energy

saving from high-level energy users' dwellings. Nevertheless, homes consuming high levels of energy are likely to be tackled in the first instance, as their potential energy saving could be 5.5 times higher than that from deep retrofit of med-level energy users' houses in our tested models. As measures on both occupant behaviour and physical improvement have influences on energy saving to various extents, integrative retrofit strategies have to be developed combining both building technologies and behavioural change to better achieve efficiency.

6.1. Limitations

It should be mentioned that the findings of this study are based on a limited data set. Particularly, only the Brunswick Centre and its seven surveyed flats have been used to describe occupants' energy use patterns and behaviours to develop retrofit strategies. In addition, theoretical scenarios have been assumed in the modelling tests, using simplified behavioural patterns for simulation. This might be the potential reason for the gaps between the highest and lowest energy use scenarios. Besides, all the modelling work assumes each room is heated with radiators. Changes in the variable of rooms heated and other behavioural assumptions (i.e. annual heating length/ temperature) may lead to different results of behavioural impact on energy saving. Finally, theoretical scenarios estimate independent effect of physical improvement and behavioural change, without taking into account the interactions between physical and behavioural variables. For example, when insulating the building envelope of a poorly insulated dwelling, the indoor temperature will rise, even if the heating pattern of the occupants remains unchanged [50].

7. Conclusions

This research has quantified the significance of occupant behaviour for energy saving from listed housing retrofit. It has also demonstrated that the impact of behavioural change exceeds

physical improvement on energy saving from retrofit, showing that it is particularly important to tackle behavioural change to improve energy efficiency in heritage homes. The findings contribute to heritage conservation and energy efficiency, compared with conventional approaches that consider mainly physical improvement. We envisage that emphasizing behaviour change would allow us to better achieve energy efficiency in listed housing and develop more robust retrofit strategies.

- Firstly, empirical findings suggest significant variations exist among occupants' energy use patterns, in particular the heating temperature setting. Modelling analyses reveal that energy use behaviour has a significant impact on the estimated energy saving in listed housing retrofit. The tests of baseline model show that with the deepest retrofit, the overall consumption remains as 2.5 times as high as a low-energy behaviour scenario without retrofit.
- Secondly, conservation behaviour change induced by policy and retrofit strategies could potentially bring substantial energy saving significantly higher than that from physical improvement. The premise for such saving is that the occupants are high-level energy users, and the measures could effectively change them to med-/low-level energy users. Findings suggest this behavioural impact on energy saving ranges up to 62% to 86% in the tested dwelling, and decreases as efficiency increases.
- Thirdly, sensitivity analyses show that heating temperature has the highest impact on energy use among behavioural variables. This means that more emphasis could be given to the heating temperature control and heating-related strategies among various conservation measures. There is room for technology improvement to stimulate

occupant behavioural changes in operation leading toward significant energy savings in listed housing retrofit.

- Fourthly, possible rebound behavioural change following retrofit could offset the energy saving from physical improvement. This backfire may happen when low-level energy users are triggered by increased energy efficiency and demand more energy services. In our modelling analysis, for example, if the occupants increase heating temperature by 1°C as comfort take-back, it could increase the energy use by 3%-5% and offset the energy saving from a 5% increase in boiler efficiency. Such behavioural change would cause a performance gap and lead to overestimation of realistic energy saving from retrofit. Thus, when retrofitting listed housing, considerations would be needed in preventing or reducing a possible rebound effect.

The scale of the debate on energy efficiency and occupant behaviour is extensive and multifaceted even at the local level. To generate achievable policy strategies and develop retrofit measures with regards to diversification, there is need for more case studies and data collections at the local level to allow further assessment of local dimensions of energy retrofit. Further analysis, and in particular the interactions between physical improvement and behavioural change, are needed to realistically bound the energy effect of occupant behaviour and extend our understanding of occupant behaviour following retrofits, in order to anticipate actual building performance and implications of retrofit strategies on behavioural change.

Acknowledgements

The authors would like to thank all the participating occupants of Brunswick, particularly David Levitt, who provided help for the data collection of the case study in this paper. The

authors are also grateful to all the reviewers for their recommendations, which have greatly helped to enhance this paper.

References

- [1] English Heritage, Energy Efficiency and Historic Buildings, English Heritage, London, 2012.
- [2] H.M. Government, Climate Change Act 2008, The Stationery Office Limited, UK, 2008.
- [3] H.M. Government, Energy Act 2010, The Stationery Office Limited, UK, 2010.
- [4] Department of Energy and Climate Change, Provisional 2009 Results for UK Greenhouse Gas Emissions and Progress towards Targets: Revised Statistical Release for End-user Emissions Estimates, Department of Energy and Climate Change, London, 2010.
- [5] Sustainable Development Commission, Building Houses or Creating Communities? A Review of Government Progress on Sustainable Communities, Sustainable Development Commission, London, 2007.
- [6] Changeworks, Energy Heritage, Changeworks, Edinburgh, 2008.
- [7] Department for Communities and Local Government (DCLG), National Planning Policy Framework, Communities and Local Government Publications, London, 2012.
- [8] S. Sorrell, The Rebound Effect: an assessment of the evidence for economy-wide energy savings from improved energy efficiency, UK Energy Research Centre, 2007.
- [9] C. Seligman, J.M. Darley, L. Becker, Behavioural approaches to residential energy conservation, *Energy and Buildings* 1 (1977) 325-337.
- [10] P.C. Stern, *Energy Efficiency in Buildings: Behavioural issues*, National Academy Press, Washington, D.C, 1985.
- [11] P.C. Stern, Towards a coherent theory of environmentally significant behaviour, *Journal of Social Issues* 56 (2000) 407-424.
- [12] J. Owens, H. Wilhite, Household energy behaviour in Nordic countries: an unrealized energy saving potential, *Energy* 13 (1988) 853-859.
- [13] L. Lutzenhiser, Social and behavioural aspects of energy use, *Annual Review of Energy and the Environment* 18 (1993) 247-289.
- [14] C. Mullaly, Home energy use behaviour: a necessary component of successful local government home energy conservation programs, *Energy Policy* 26 (1998) 1041-1052.
- [15] L. Steg, Promoting household energy conservation, *Energy Policy* 36 (2008) 4449-4453.

- [16] O. Guerra-Santin, L. Itard, H. Visscher, The effect of occupancy and building characteristics on energy use for space and water heating in Dutch residential stock, *Energy and Buildings* 41 (2009) 1223-1232.
- [17] O. Guerra-Santin, L. Itard, Occupants' behaviour: determinants and effects on residential heating consumption, *Building Research and Information* 38 (2010) 318-338.
- [18] K. Gram-Hansen, Residential heat comfort practices: understanding users, *Building Research and Information* 38 (2010) 175-186.
- [19] K. Gram-Hansen, Households' energy use – which is the more important: efficient technologies or user practices, in *Proceedings of the World Renewable Energy Congress 2011*, Linköping, Sweden.
- [20] R. Haas and P. Biermayr, The rebound effect for space heating – Empirical evidence from Austria, *Energy Policy* 28 (2000) 403-410.
- [21] M. Sunikka-Blank, R. Galvin, Introducing the prebound effect: the gap between performance and actual energy consumption, *Building Research and Information* 40 (2012) 260-273.
- [22] N. Baker, K. Steemers, *Energy and Environment in Architecture: A Technical Design Guide*, Taylor & Francis, London, 2000.
- [23] K. Steemers, G.Y. Yun. Household energy consumption: a study of the role of occupants, *Building Research and Information* 37 (2009) 625-637.
- [24] Energy Saving Trust, *Domestic Energy Efficiency Primer (GPG171)*, Energy Saving Trust, London, 2003.
- [25] Energy saving trust, *Energy Efficient Historic Homes – Case Studies (CE138)*, Energy Saving Trust, London, 2005.
- [26] English Heritage, *Conservation Principles Policies and Guidance*, English Heritage, London, 2008.
- [27] English Heritage, *Energy Conservation in Traditional Buildings*, English Heritage, London, 2008.
- [28] English Heritage, *Climate Change and the Historic Environment*, English Heritage, London, 2012.
- [29] British Standards Institution, *Guide to the Principles of the Conservation of Historic Buildings (BS 7913)*, London: British Standards Institute, 1998.
- [30] City of Westminster, *Retrofitting Historic Buildings for Sustainability*, Westminster City Council, London, 2013.

- [31] F. Ascione, F. Rossi, G.P. Vanoli, Energy retrofit of historical buildings: theoretical and experimental investigations for the modeling of reliable performance scenarios, *Energy and Buildings* 43 (2011) 1925-1936.
- [32] Integrated Environmental Solutions, 2013, Integrated Environmental Solutions <<http://www.iesve.com>> (accessed 02.03.13).
- [33] H. Ben, 'Energy Retrofit and Occupant Behaviour in Listed Housing.' MPhil Thesis, University of Cambridge, 2013.
- [34] P. Morgenstern, 'Identifying challenges to the introduction of heat meters in poorly-performing district-heated apartment blocks.' MRes Thesis, University College London, 2012.
- [35] A. Stafford, *The Retrofit Challenge: Delivering Low Carbon Buildings*, The Centre for Low Carbon Futures, 2011.
- [36] Energy Saving Trust, <www.energysavingtrust.org.uk> [accessed 09.02.13];
- [37] Energy Saving Trust, *Energy-efficient Refurbishment of Existing Housing (CE83)*, Energy Saving Trust, London, 2007.
- [38] Construction Products Association, *An Introduction to Low Carbon Domestic Refurbishment*, Construction Products Association, London, 2010.
- [39] BRECSU, *Good Practice guide 224: Improving airtightness in existing homes*, Building Research Establishment, Garston, UK, 1997.
- [40] S. Monahan, A. Gemmill, *The impact of occupant behaviour and use of controls on domestic energy use*, IHS BRE Press on behalf of NHBC Foundation, 2012.
- [41] P. Wouters, D. De Baets, 'A detailed statistical analysis of window use and its effect on the ventilation rate in 2400 Belgian social houses' in 7th AIC Conference: Occupant interaction with ventilation systems, Stratford-upon-Avon, UK, 29 September- 2 October, 1986.
- [42] B. Boardman, S. Darby, G. Killip, M. Hinnells, C. Jardine, J. Palmer, G.Sinden, *40% House*, Environmental Change Institute, University of Oxford, 2005.
- [43] BRE, *The Government's Standard Assessment Procedure for Energy Rating of Dwellings (SAP): 2009 Edition*, Building Research Establishment, Garston, UK, 2012.
- [44] J. Love, *Mapping the impact of changes in occupant heating behaviour on space heating energy use as a result of UK domestic retrofit*, 2012.
<www.salford.ac.uk/_data/assets/pdf_file/0005/142385/023-Love.pdf> [accessed 02.03.13].

- [45] L. Gobio-Lamin, 'Are window opening behaviours to blame for domestic heating energy use not declining despite dwellings becoming more energy efficient?' PHD Thesis, University College London, 2012.
- [46] V. Cheng, K. Steemers, Modelling domestic energy consumption at district scale: A tool to support national and local energy policies, *Environmental Modelling & Software* 26 (2011) 1186-1198.
- [47] A. Saltelli, K. Chan, E.M. Scott, *Sensitivity Analysis*, John Wiley & Sons Ltd., West Sussex, England, 2000.
- [48] S.K. Firth, K.J. Lomas, A.J. Wright, Targeting household energy-efficiency measures using sensitivity analysis, *Building Research and Information* 38 (2010), 25-41
- [49] S.N. Murray, D.T.J.O'Sullivan, 'An optimization methodology and sensitivity analysis of existing building retrofits.' Paper presented at First Building Simulation and Optimization Conference, Loughborough, UK, 10-11 September, 2012.
- [50] M. Deurinck, D. Saelens, S. Roels, The impact of physical rebound effects on the heat losses in a retrofitted dwelling, 9th Nordic Symposium on Building Physics – NSB 2011, Volume 3.

List of figures

Fig.1. Retrofit Model Framework (RMF)

Fig.2. The baseline model created in IES

Fig.3. Structure of the validation and calibration process

Fig.4. Comparison of energy use regarding mean heating temperature in Brunswick flats

Fig.5. Comparison of energy use regarding flat orientation in Brunswick flats

Fig.6. Energy use comparison among different retrofit levels with three behavioural scenarios

Fig.7. Energy saving comparison from physical improvement at three behavioural scenarios

Fig.8. Energy saving comparison among different retrofit levels from behavioural change

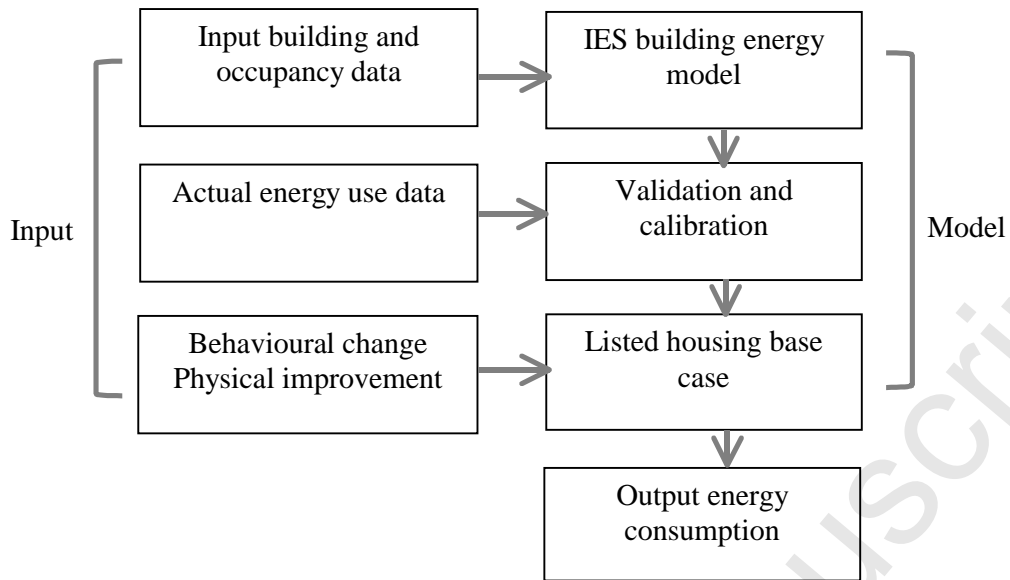

Fig.1. Retrofit Model Framework (RMF)

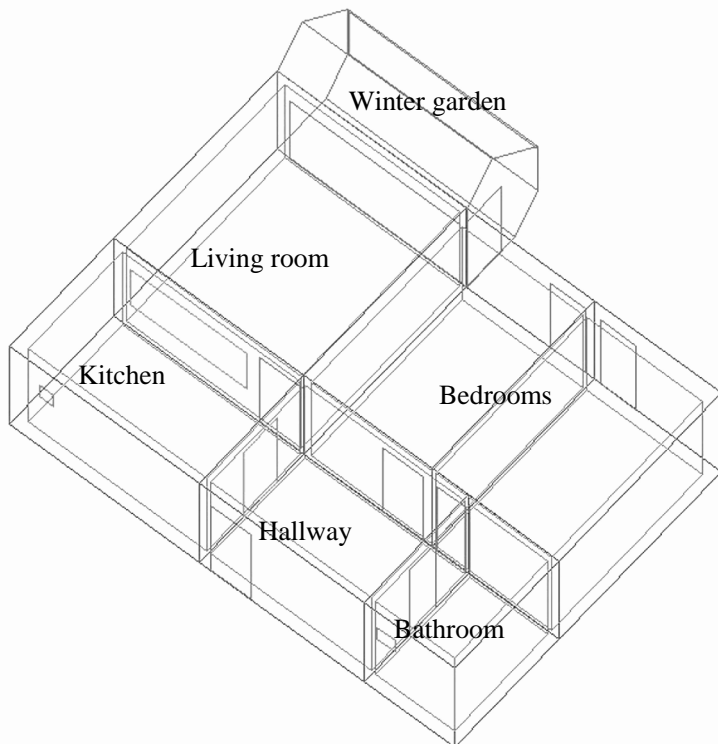

Fig.2. The baseline model created in IES

Modelled
performance

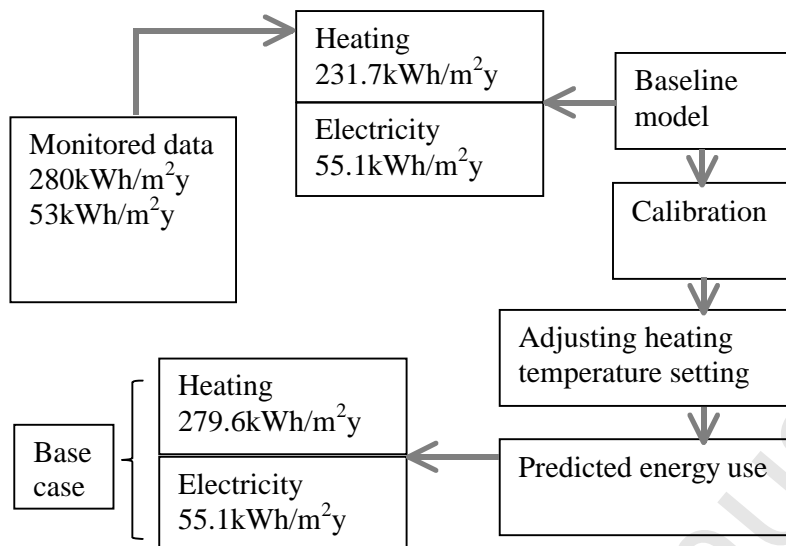

Fig.3. Structure of the validation and calibration process

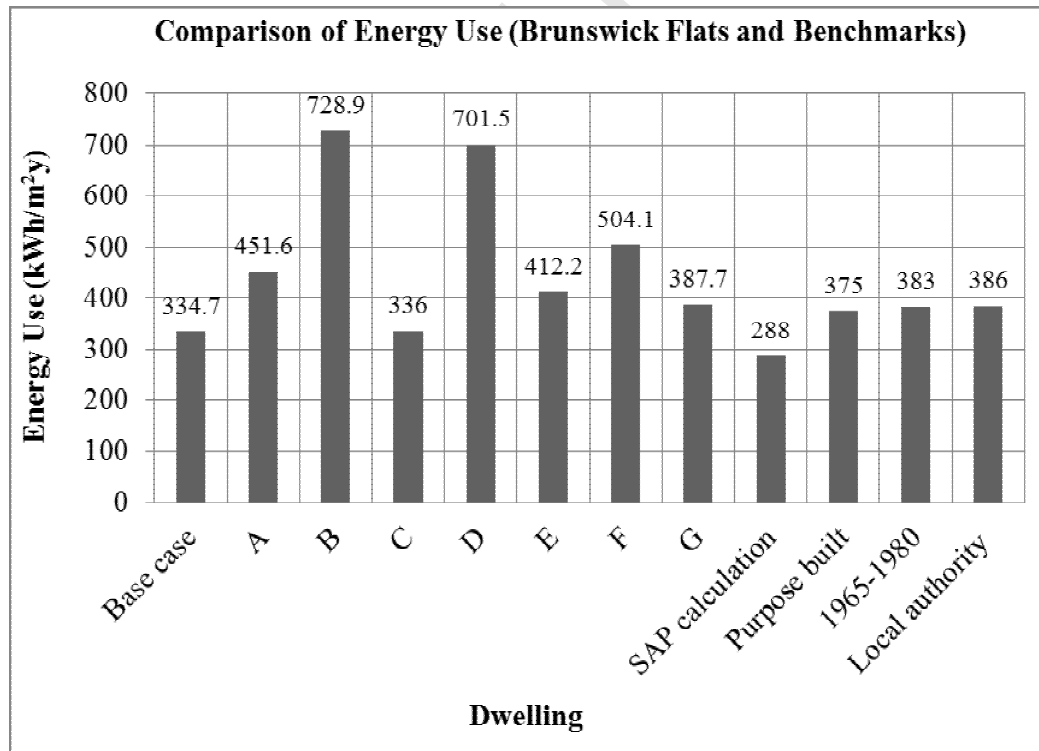

Fig.4. Comparison of energy use in the Brunswick flats to other benchmarks.

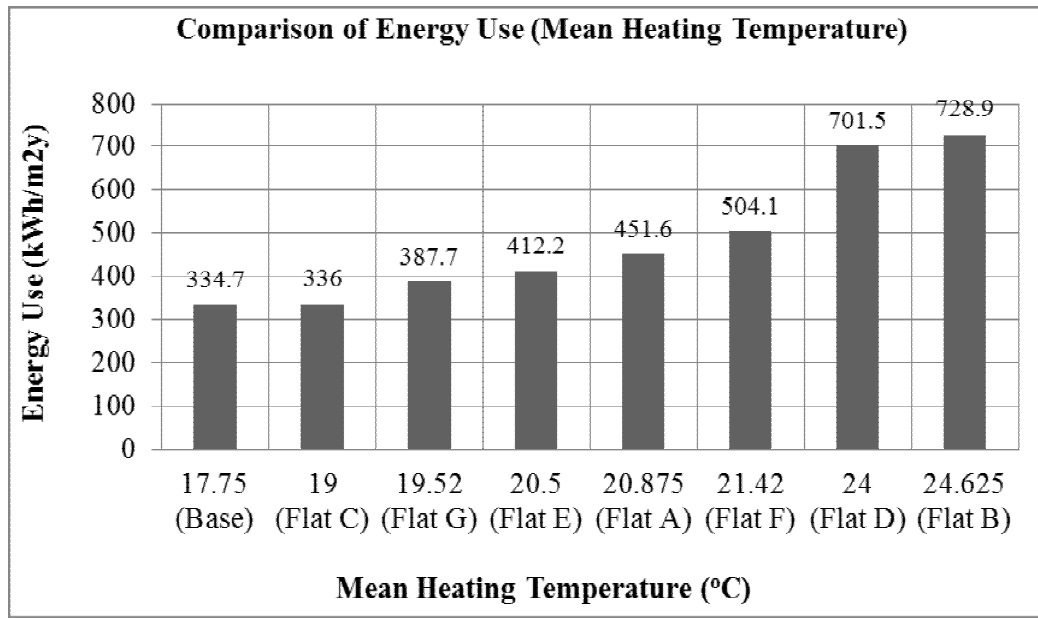

Fig.5. Comparison of energy use for mean heating temperature in the Brunswick flats.

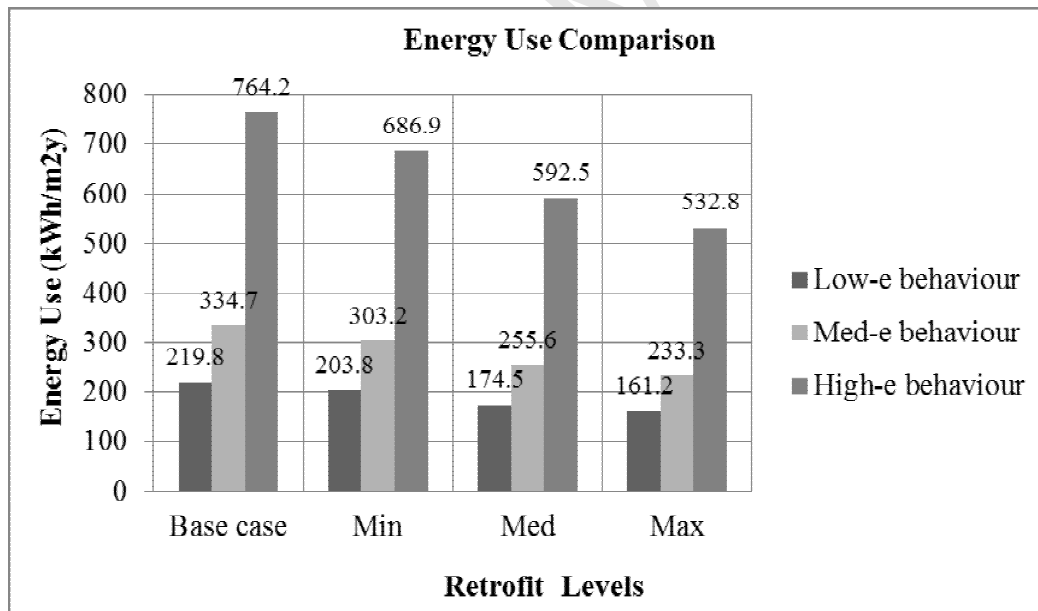

Fig.6. Energy use comparison among different retrofit levels with three behavioural scenarios

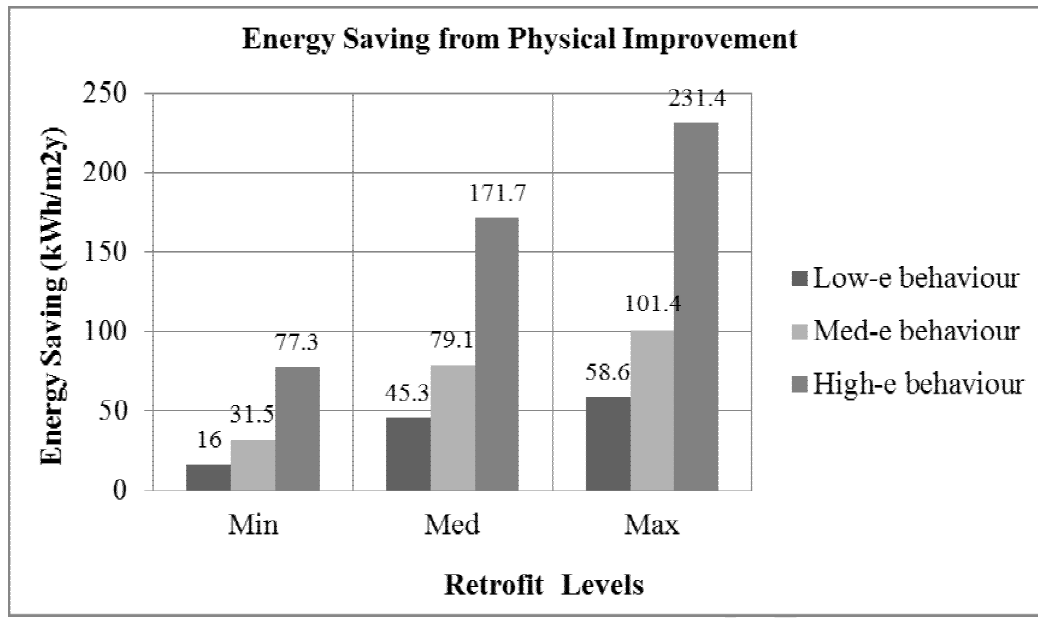

Fig.7. Energy saving comparison from physical improvement at three behavioural scenarios

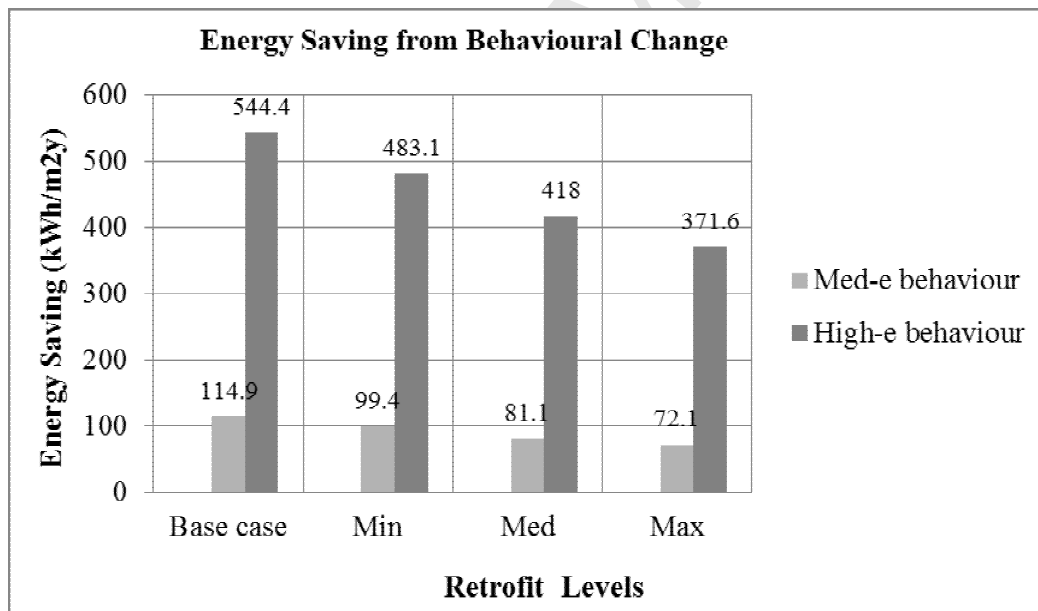

Fig.8. Energy saving comparison among different retrofit levels from behavioural change (Low-e behaviour is the baseline for med and high behaviour to change).

Table 1

Construction profiles for the base case

Construction	Description	Thickness (mm)	U-value* (W/m ² K)
External wall (external front and back)	Themalite blocks with cavity	250	1.7
Party wall (between flats)	Bricks with cavity	215	1.6
Floor/ceiling	In-situ concrete	200	1.2
Front door	Wood	40	3.0
Winter garden rooflight	Double-glazing with metal frame, argon filled (low-E, 0.2, hard coat)	15	2.9
Winter garden vertical glazing	Single-glazing with metal frame	6	5.7
External wall below window	Concrete block with cavity	230	1.7
Kitchen and bathroom window	Single glazing with metal frame	16	5.7
Balcony door	Single glazing with metal frame	6	5.7

* Figures taken from the Standard Assessment Procedure (SAP) 2009.

Table 2

Standardised input behavioural parameters (SAP 2009, BREDEM-8)

Input	Heating temperature	Heating schedule	Window opening
Settings	21°C: living room	Weekdays: 7am-9am/4pm-11pm; weekends: 7am-11pm	Bedrooms/winter garden windows 7am - 9am
	18°C: other rooms		
	15°C: whole flat	The rest of the time not specified above	

Table 3

Input parameters from IES system data or ASHRAE and CIBSE Guide

Ventilation	Natural ventilation	1.0ach (window opening/ passive vents)
	Infiltration	0.25ach per window/door (all the windows/ doors, i.e. Winter garden 1.5ach, bedroom 0.5ach)
	Auxiliary ventilation	3.0ach (bathroom)
Internal gains	Occupants	90.0W/person
	Fluorescent lighting	12W/m ²
	Computers	8.0W/m ²
	Miscellaneous	30.0W/m ²
	Cooking	30.0W/m ²
Lighting	Design light level	500lux
	Horizontal surface height	0.85m
DHW	Delivery efficiency	0.80
	Mean water inlet	10°C
	Hot water supply	60°C
	Storage volume	100L
	Daily loss factor	0.0075kWh/L
Other factors	Solar reflected fraction	0.05
	Furniture mass	1.00

Table 4

Standardised input behavioural parameters after calibration

Input	Heating temperature	Heating schedule	Window opening
Settings	21°C	Weekdays: 7am-9am/4pm-11pm; weekends: 7am-11pm	Bedrooms/winter garden windows 7am - 9am
	15°C	The rest of the time not specified above	

Table 5

Energy use and behaviour patterns of surveyed flats

Flat	Heating Pattern	Window Opening	Occupancy/ Orientation	Energy Use (gas + electricity) (kWh/m ² y)
Base case	Weekdays: 21°C 7am-9am/4pm-11pm; Weekends: 7am-11pm Rest of the time: 15°C	Bedroom/Winter garden windows 7am - 9am	2 occupants; West-facing	334.7
A	7am-8.30am (23°C), 8.30am- 5.30pm (19°C), 5.30pm- 11.30pm (23°C), 11.30pm- 7am (21°C)	Bedroom windows 12pm-2pm	5 occupants; East facing	451.6
B	7am-6pm (23°C), 6pm-7am (26°C)	Winter-garden windows 2pm-3pm	1 occupant; West facing	728.9
C	24hours (19°C)	Bedroom/Winter- garden windows 12pm-6pm	2 occupants; West facing	336.0
D	24 hours (24°C)	Bedroom windows 12pm-2pm	3 occupants; East facing	701.5
E	7am—11pm (21°C), 11pm-7am (19°C)	Winter-garden windows 2pm-3pm	2 occupants; East facing	412.2
F	9am-11.30pm (23°C), 11.30pm-9am (19°C)	Bedroom/Winter- garden windows 12pm-2pm	1 occupant; West facing	504.1
G	6am-8.30am (22°C), 8.30am-4.30pm(20°C), 4.30pm-10.30pm(21°C), 10.30pm—6am (17°C)	Bedroom/Winter garden windows 12pm-6pm	2 occupants; West facing	387.7

Note: Temperature settings are adjusted and averaged according to data logger monitoring results and questionnaire survey. All rooms have radiators except the kitchens.

Table 6

Comparison of SAP results for Brunswick mean energy use to benchmarks [34]

Mean energy use in kWh/m ² y			
SAP model for Brunswick flats		English Housing Survey 2007	
Mid-floor, west facing	288	Purpose built flat, low rise	375
Mid-floor, east facing	317	Flat, 50 to 69m ²	420
Top-floor, west facing	408	1965-1980	383
Top-floor, east facing	443	Local authority	386

Table 7

Measures for building fabric with genetic target U-value, cost and payback period

Measure	Target U-value */ Infiltration rate **	Capital Cost*	Payback period*
Cavity wall insulation	0.5-0.6 W/m ² K	£500	5yrs
Roof insulation	0.25 W/m ² K	£350	5yrs
Secondary glazing	2.7 W/m ² K	£200	8yrs
Draughtproofing	0.05ach per window/door	£90 (DIY)	5yrs

* Figures taken from [1,24,30,36-38].

** Figures taken from [39].

Note: These figures are only an indication, and will be affected by actual contracts and different specifications within each measure.

Table 8

Modelled energy use and energy saving following building fabric retrofit for Brunswick

Retrofit measure	U-value/Infiltration rate	Energy	Energy saving
------------------	---------------------------	--------	---------------

	Before	After	use kWh/ m ² y	kWh/ m ² y	% change
Base case	—	—	334.7	—	—
Wall insulation	1.7W/m ² K	0.5W/m ² K	304.6	30.1	8.99%
Secondary glazing	5.7W/m ² K	2.7W/m ² K	313.8	20.9	6.24%
Draughtproofing	0.25ach	0.05ach	315.1	19.6	5.86%
All measures above	Sum above	Sum above	264.5	70.2	20.97%

Note: The above is calculated under the ‘standard behaviour pattern—medium-energy behaviour’ scenario specified in Table 4. Roof insulation is not included as the model is based on one mid-floor flat.

Table 9

Measures for system with genetic target efficiency, cost and payback period

Measure	Target absolute efficiency	Capital cost*	Payback period*
Hot water cylinder insulation	85%	£12	6 months
Pipework insulation		£10	1 year
Boiler upgrade	90%	£2,300	>10 years

* Figures taken from [6,24,36,37].

Table 10

Modelled energy use and energy saving following system improvement

Measure	Efficiency		Energy use (kWh/ m ² y)	Energy saving	
	Before	After		kWh/ m ² y	% change
Base case	—	—	334.7	—	—
Insulation of cylinder and pipes	80%	85%	321.6	13.1	3.91%
Boiler upgrade	80%	90%	303.6	31.1	9.29%

Both measures above	Together above	Together above	292.0	42.7	12.76%
---------------------	----------------	----------------	-------	------	--------

Table 11

Energy use and saving at each retrofit level (assuming Medium energy behaviour – see Section 5.2.2)

Retrofit Level	Measures	Energy use kWh/ m ² y	Energy saving	
			kWh/ m ² y	% change
Min-retrofit	Insulation of hot water cylinder and pipework, draughtproofing	303.2	31.5	9.41%
Med-retrofit	Insulation of hot water tank and pipework, draughtproofing, cavity wall insulation, secondary glazing	255.6	79.1	23.63%
Max-retrofit	Insulation of hot water tank and pipework, draughtproofing, cavity wall insulation, secondary glazing, boiler upgrade	233.3	101.4	30.30%

Table 12

Energy use with low-energy behaviour at different retrofit levels, compared to the base-case of medium-energy behaviour

Variable	Heating temp (°C)	Heating schedule	Window opening	Retrofit levels	Energy use	
					kWh/ m ² y	% change
Low-energy behaviour	18	Weekdays: 7am-9am/4pm-11pm; weekends:	—	Base case	219.8	—
				Min	203.8	-7.28%
				Med	174.5	-20.61%

		7am-11pm		Max	161.2	-26.66%
--	--	----------	--	-----	-------	---------

Table 13

Energy use with high-energy behaviour at different retrofit levels

Variable	Heating temp (°C)	Heating schedule	Window opening	Retrofit levels	Energy use	
					kWh/m ² y	% change
High-energy behaviour	24	24 hours	24 hours	Base case	764.2	—
				Min	686.9	-10.12%
				Med	592.5	-22.47%
				Max	532.8	-30.28%

Table 14

Range of input nominal values used in the sensitivity tests

Retrofit measure	Input parameter	Nominal value*	Test range	Sensitivity
Boiler upgrade	Seasonal efficiency	85%	±50%	-0.75%
Tank and pipe insulation	Delivery efficiency	82.5%	±40%	-0.60%
Secondary glazing	Window U-value	4.2 W/m ² K	±10%	0.16%
Cavity wall insulation	Cavity wall U-value	1.1 W/m ² K	±10%	0.08%
Draughtproofing	Infiltration rate	0.15 ach	±60%	0.05%

* Nominal value has been assigned based on the average value for the parameter of the base case before and after retrofit. The test range for each parameter is chosen according to its value pre-and-post retrofit. When testing each parameter above, the rest settings stay the same as base case values and medium-energy behaviour scenario.

Table 15

Range of input nominal values used in the sensitivity tests

Behaviour Variable	Nominal value*	Test range	Sensitivity
--------------------	----------------	------------	-------------

Heating temperature	21°C	±20%	3% - 5%
Heating length	10 hours	±50%	0.3% - 0.5%
Window opening length	10 hours	±50%	0.04% - 0.05%

Accepted Manuscript