



Capturing composites manufacturing waste flows through process mapping



Justyna Rybicka^a, Ashutosh Tiwari^{a,*}, Pedro Alvarez Del Campo^a, Jack Howarth^b

^a Manufacturing and Materials Department, Cranfield University, UK

^b School of Mechanical, Aerospace and Civil Engineering, University of Manchester, M13 9PL, UK

ARTICLE INFO

Article history:

Received 7 April 2014

Received in revised form

5 December 2014

Accepted 8 December 2014

Available online 16 December 2014

Keywords:

Material flow analysis

Composites recycling

Waste flow capturing

ABSTRACT

The necessity of high performance materials has become latent in high technology sectors such as aerospace, automotive, renewable energy, nuclear engineering and sports. The expanding impact on future manufacturing of the EU waste management legislation and increasing price of current waste management methods stress the importance of an efficient and sustainable way of recycling waste generated in the composites industry. Aerospace companies estimated that 30–50% of materials in aircraft production are scrapped due to the way it is manufactured. Companies need to pay for landfilling the composite materials that otherwise can be a valuable resource. In a view that looking at individual production waste outputs could maximise the material reuse or recycling capability, gaining information about the type of scrap materials could inform the development of composite reuse/recycling supply chain. This research paper focuses on understanding the scale of scrap created in individual composites manufacturing processes to assess its potential value in terms of reuse/recycle capabilities. A Material flow analysis based data collection workshop has been performed with four composite manufacturers. Through the case studies it has been identified that there are three fibre related waste outputs captured: dry fibres, fibre material sheet off-cuts, and curried composite off-cuts. The captured information allows for the material specification development. This allows bridging the gap between the manufacturers and the waste processors in composites to address the lack of infrastructure and lack of waste material specification barriers outlined by the Composites Strategy 2009.

© 2015 The Authors. Published by Elsevier Ltd. This is an open access article under the CC BY license (<http://creativecommons.org/licenses/by/4.0/>).

1. Introduction

The necessity of high performance materials has become latent in high technology sectors such as aerospace, automotive, renewable energy, nuclear engineering and sports. Composite materials permit the possibility of reducing weight while increasing mechanical strength and harbour the capacity to form complex shapes, leading to high functionality and fuel efficiency (ESPRC Grant EP/K026348/1). As detailed by Morin et al. (2012), high fatigue, corrosion resistance and low thermal expansion, in addition to the properties mentioned above, are boosting the use of carbon fibre composites in the aforementioned sectors.

Job (2009) and Lifting Off report (2013) predicts that continued growth is expected in this industry due to new applications and

increased production of composites in several industries. Currently, main users of the composite parts produced in the UK are: Aerospace (36%); Wind Energy (33%); Automotive (8%); and Marine (8%) industries (Ernst and Young, 2010). This increase in composites use has been observed worldwide, as reflected by raising carbon fibre demand; from 35,400 tonnes in 2008 to an expected 70,800 tonnes by 2014 (Roberts, 2009). This implies that the amount of composite scrap produced is going to rise, but also that those composites will require waste management once the manufactured product reaches its end of life.

Historically, the main waste management options for composites have been landfilling and incineration. However, it is claimed that changes in legislation will that make it necessary to research new and feasible composite waste management options. Firstly, spurred by the 'polluter pays' principle, tax legislation for landfill waste has increased and the cost of disposal in the UK rose from £7 per tonne (£/T) in 1996 to £72/T in 2013. In addition, the European Union (EU) Directive on Landfill Waste (1999/31/EC) reduced the amount of organic material permitted in landfill; composite's

Abbreviations: EPSRC, The Engineering and Physical Sciences Research Council.

* Corresponding author. Tel.: +44 01234 75 0111.

E-mail address: a.tiwari@cranfield.ac.uk (A. Tiwari).

landfilling has already become illegal in Germany. Furthermore, the EU directive on waste incineration (2000/76/EC) limits the emission of pollutants coming from waste incineration and co-incineration. In light of composite material usage in the automotive industry, the End-of-life Vehicle Directive (2000/53/EC), which states that at least 85% of the mass of new vehicles must be recycled or reused, 10% must be recoverable and only 5% may be disposed of in landfill by 2015, there is a vast web of legislation to consider in the manufacture and waste management of composite materials. The mentioned legislation will impact the waste management of composites in the industry as it will need to look for alternative ways of processing composite waste. This creates opportunities for research and development (R&D) to explore novel composite recycling strategies (i.e. reduce, reuse and recycle).

The expanding impact on future manufacturing of the EU waste management legislation (Yang et al., 2012; Miliutenko et al., 2013) and high price of current waste management methods (Palmer et al., 2009) stress the importance of an efficient and sustainable way of recycling waste generated in the composite industry. Diversification of the waste management options for composite materials will enable lower costs for this waste management in comparisons to landfill or incineration and the recovery of some of the materials.

Due to defragmentation and different stages of maturity of recycling and recovery technologies (BIS, 2013), data on waste management practices and volumes is difficult to find. Although there are existing estimations on the carbon fibre reinforced plastics (CFRP) and glass fibre reinforced plastics (GFRP) waste numbers, this general approach does not allow capturing the value locked within the materials classed as waste from manufacturing (Conroy et al., 2006). EADS estimated that 30–50% of materials in aircraft production are scraped due to the way it is manufactured. Companies need to pay for landfilling the composites materials that otherwise can be a valuable resource.

In a view that looking at individual production waste outputs could maximise the material reuse or recycling capability, gaining information about the type of scrap materials could inform the development of composite reuse/recycling supply chain. It is also vital to recognise the types of processes and types of scrap that is produced by manufacturers individually in order to identify potential varieties of waste management methods that could potentially replace or complement current composites waste management. In a pursuit to translate that thinking this paper aims to demonstrate methodology for capturing scrap flows from composite manufacturers. The following objectives have been established to complete the research aim:

- Development of data collection method for material and scrap flow from composites manufacturing process
- Characterisation of the types of materials at their point of use, and the amount, quality and point of creation of scrap

2. Related research in process mapping tools in composites manufacturing

Managing waste from manufacturing better is a growing area of research contributing to the field of sustainable manufacturing and energy efficiency as well as quite recently to the field of circular economy (Mouzon et al., 2007).

Tools for resource flow mapping are widely used for manufacturing optimisation where process mapping allows to realise the 'as is' scenario and act as a benchmark for improvement activities (Smith & Ball, 2012). These tools usually focus on the material flow as a contribution to the production process (Smith &

Ball, 2012). Process mapping is considered an appropriate way of capturing data in the context of waste mapping as it allows capturing materials and subsequently waste from the manufacturing processes. For example, value stream mapping tool enables organisations to work towards four objectives: eliminating waste, maintaining inventory control, product quality improvement and financial and operation control (Fawaz and Rajgopal, 2007). Bolin and Smith (2011) describe benefits of manufacturing process improvement through use of IDEFO (process modelling tool) and MEW (material energy, waste mapping) analysis as enabling improvement opportunities for economic improvement through resource minimisation. The tools that have been used for process mapping with intent to outline waste are: value stream mapping, Sankey diagrams, material flow analysis, IDEFO, MEW and flow charts (Fawaz and Rajgopal, 2007; Rahani et al., 2012; Kahlat and Willims, 2012).

Process mapping tools serve to provide information to fulfil two functions in the understanding of waste in production: in preventive activities where realisation of waste streams allows searching for minimisation options; and in informing activities where data on types of waste allows understanding the volumes and nature of waste in order to be able to reuse/recycle it better (Smith & Ball, 2012).

Process mapping tools have been used to identify waste that is 'most suitable for transformation' by Burmeister et al. (2010). That suggests that process mapping is concentrating on waste where potential of maximisation of value from transforming waste is possible.

The waste hierarchy presented in the EU waste framework directive in 2008, introduces scale to classify the different types of waste in five levels according to their management procedures (Fig. 1). The five levels defined by the directive 2008/98/EC classify waste management in different forms of waste treatment: from prevention which is the most desirable (non-waste) scenario, through to waste disposal, which is considered the most wasteful currently known process.

Research efforts in relation to composite waste focus on recycling technologies development and testing (Yang et al., 2012; Pickering, 2006; Jiang et al., 2007; Palmer et al., 2009) and reuse of composite waste (Ahmad et al., 2012). Limited research has been done in composites manufacturing process capture for waste mapping in detail. Many efforts in understanding waste characteristics focus on informing contextual reasoning behind improving waste management of waste at all management stages. Therefore, the types of information gathered are general, usually providing volumes and groups of material types waste. For instance, WRAP Scoping study (2013) looks at the amount of carbon fibre and glass fibre produced by sector to present that scale of potential waste volumes, stating that at 2010 there has been 87,000t of Glass fibre reinforced plastics (GFRP) and 2,500t of carbon fibre reinforced plastics (CFRP) produced. This can provide a picture of the future disposal requirements. However, the industry is interested in process mapping tools suggesting that many of the waste management efforts are performed internally in the organisations but it is not accessible. Also, Smith, et al. (2012) suggests that general trends in sustainable manufacturing of reducing waste flows lacks of practical guidance into how to identify and implement opportunities for material flow reduction.

This study therefore focuses on demonstration of how process flow mapping can facilitate material waste capture from composite manufacturing processes to capture the waste volume and characteristics to maximise understanding of potential reuse and recycling options. Further, potential energy savings are highlighted through comparison of the unit process energies of suitable recycling processes with the embodied energies of virgin carbon and glass fibres.

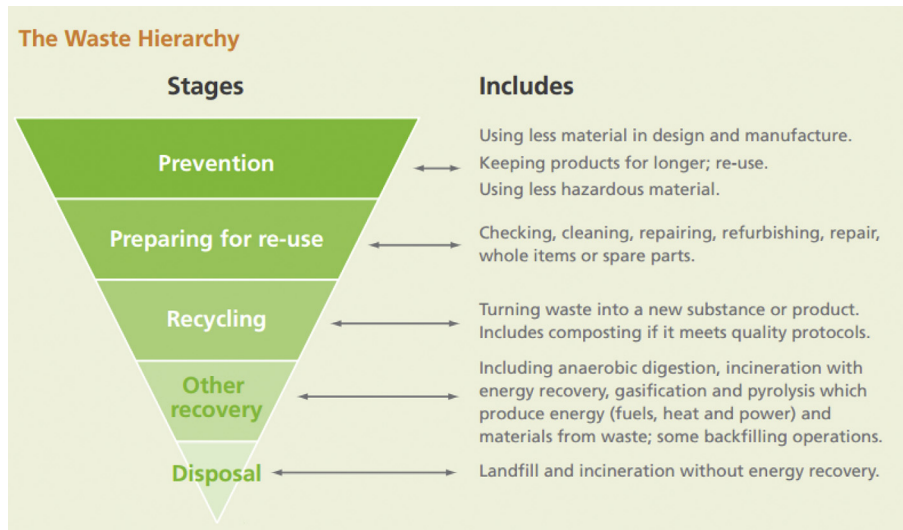

Fig. 1. EU waste framework.
Source: DEFRA (2011) Government Review of Waste Policy in England 2011.

3. Methodology

Qualitative research methodology has been selected as appropriate due to the limited number of organisations participating in this study. Five organisation have participated in the study, however as not enough information have been provided by one company, only results from four of the organisations are used in this paper. As mentioned before, the research focuses on understanding the scale of scrap created in composites manufacturing as well as its potential value in terms of reuse/recycle capabilities for an organisation. Additionally, to be able to interpret the data, the collection techniques are required to deliver in-depth resource flow understanding and well-defined context of the production reality. That is why the data collection was selected to be a one-to-one workshop that combines structured interview and semi-structured interview. The semi-structured interview required participant to provide specific data around the manufacturing process. This activity aimed to map material flow from manufacturing process that captured the information outlined in Table 1. This information was captured through set of cards designed to allow material flow map creation in real time. The participants fill in the cards themselves to ensure

that the content is unbiased by the researcher. Following that, the open-ended set of questions has been asked to establish the context of the current production process in terms of its strategic positioning for improvement/innovation in the area of waste management. The questions aimed to provide the benchmark between the ‘as-is’ and the ‘improved’ scenario.

The workshop was broken down to the following steps:

- Background (research context introduction)
- Boundary setting (company details, manufacturing process definition, material definition, date)
- Process development (activity mapping)
- Resource flow representation (materials and outputs mapping)
- Outlook insight questions (potential for process improvement-unspecified improvements focussing on the whole process rather than materials only)

3.1. Understanding waste management improvement scope through the outlook questions

Four open ended questions were asked to the key employees involved in manufacturing process or managing of manufacturing process establish the view on improvement potential and to act as a trigger for different angles of innovation in recyclability from manufacturing process:

- What would you change in this process?
- What Scrap has reuse potential? In which industry?
- What scrap/waste do you think could be easily reduced? How?
- What innovation do you think should happen?

3.2. Process modelling tool selection

The most common mapping tools used in manufacturing are: flow chart, material flow analysis, value stream mapping and IDEF0. The process modelling technique has been assessed based on the following criteria:

Table 1
Capturing data mechanisms in the one-to-one workshop.

Data capture requirement	Captured by
Process used in composites manufacturing	Organisational data sheet
Type of material in production	Activity cards
Activities contributing to final product	Material cards
Materials and additional resources required for subsequent steps	Material cards + output cards
Volume and composition of material used in correlation to the final product	Output cards
Volume and composition of scrap materials	Output cards
Scrap management practices	Material flow summary table
Final product/full material used in production	

1. *Capture different scope ranges.* The required model needs to capture simplified manufacturing process. However at later stages the scope will be widen to the whole sector, comparing the manufacturing processes of different companies. Further the research might be widened to the whole composites industry, allowing the comparison between the different sectors with the composites use.
2. *Capture the manufacturing process activities.* The technique has to be able to show all the steps of the process in order to identify where the scrap and waste material is created.
3. *Represent the product manufacturing flow:* The technique has to capture and represent the flow of resources required to create the product.
4. *Quantify the amount of created product:* The technique has to capture and represent the amount of product (physical units or percentages).
5. *Capture the created scrap and waste material:* the technique has to capture and represent the flow of scrap and waste material created after every step of the process and where is it sent.
6. *Quantify the amount of scrap and waste material created:* the technique has to capture and represent the amount of scrap and waste material created after every step of the process and where is it sent.
7. *Represent the results in an intuitive way:* results presented in a way that is easy to understand for people unfamiliar with the technique.
8. *Detail the process' steps:* the details within every single step of the process, such as who is doing it or what technology involved is captured in the model. This requirement was thought in the opposite way. This kind of information is not relevant for the resource flow and many companies do not want to share such private data. The tool was able to capture the resource flows throughout the steps without digging in details would be the best one.
9. *Have gathered data compatible with other techniques:* gathered data of the technique can be used if it is necessary to apply to a different one. This is not strictly necessary for this research but the aim is to make the captured data useful for next studies.
10. *Have clear rules for the model creation:* the technique has strong rules for the model creation, assuring consistency and homogeneity every time it is applied.

Table 2 shows the results of the comparison analysis. It was identified that IDEF0 and Material Flow Analysis meet almost all the requirements, thus both techniques could be useful for the

Table 3
Information requirements reasoning.

Type of information required	What does it provide
Quantities of scrap material	Scope of potential recycling demand
Types of scrap material	Indication on recycling technologies that might be appropriate for the types of scrap
Final product composition/full material used in production	Define the scope of waste created within the specific manufacturing processes – potential room for improvement

research. However, there are two main differences that made Material Flow Analysis (MFA) the most appropriate for the purpose of this study. Firstly, MFA's representation is more intuitive than IDEF0's making it more user friendly. Secondly, as explained before, MFA does not need to dig into confidential data to capture the process and resource flow, which enables companies to collaborate without fears of confidentiality breaches.

Material flow analysis tool had been chosen as most appropriate mapping tool to deliver the required objectives within the semi-structured interviews. The modelling of the composite manufacturing process has enabled capturing and characterization of scrap. By identification of the scrap types and its treatment after production data on the waste management options could be collected. This data collection technique allows to feed in the information to the process modelling tool without need for transformation.

Also, as the actual production numbers are often confidential the material capture exercise was focused on realising the waste output as the percentage of the total amount of material (TAM) used. To provide the perspective on the potential scale of waste produced in the actual numbers, the company was asked to identify the 'scale' of production activity their factory is operation on. The choice was Small – prototypes to 100 pars per production, Medium- 100 – 10,000 pars per production, Mass-production – >10,000.

Table 3 summarises the rationale behind the type of information required to allow the MFA process to be completed. Apart from capturing the process it is important to be able to capture the information around volumes and specifications of materials in a systematic way.

STAN 2 is software developed by the Vienna University of Technology that is supporting the Austrian ONORM 2096 standard on waste management (Cencic, 2008). This software delivers process maps visualising the manufacturing process with inclusion of required data: volumes of resource inputs and outputs. This is achieved by use of the MFA process and Sankey arrows to visualise volumes of required resources.

Table 2
Process mapping tool comparisons.

	Capture different scope ranges	Capture required process elements	Represent product manufacturing flow	Capture the material flow quantities	Capture waste and scrap materials	Capture waste and scrap flow quantities	Represent results in a intuitive way	Capture of specific process details	Compatibility with other tools/software	Uniform rules for model creation
Material Flow Analysis ^a	x	x	x	x	x	x	x	a	x	
Value Stream Mapping ^b		x	x		x		a	a	x	
IDEF0 ^c	x	x	x		x		a	x	a	
Flow Chart ^d	x	x	x	x	x	x	x	a	a	

x – meets the criteria, a – partly meets the criteria; blank-does not meet the criteria.

^a Material Flow Analysis (MFA) – systemic assessment of the flows and stocks of materials within a system defined in space and time (Brunner and Rechberger, 2004).

^b Value Stream Mapping (VSM)- a micro-level analysis of material and information flow through the various levels of a manufacturing setup (Vinodh et al., 2010), (Fawaz and Rajgopal, 2007).

^c ICAM (Integrated Computer Aided Manufacturing) Definition for Functional Modelling (IDEF0) – represent complex systems by mean of simple graphical diagrams.

^d Flow Chart – is a graphical representation of a system that describes the logical sequence of the steps within a process (Aguilar-Savén, 2004).

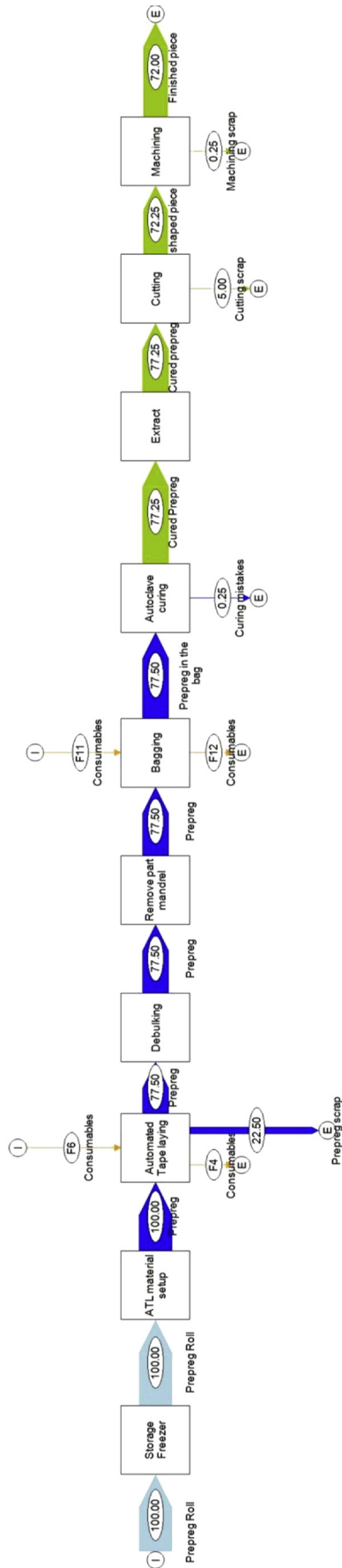

Graph 1. Company 1 material flow analysis (generated with STAN2 software); (I –Input, E–material output).

4. Results

This section displays the results of 4 interviews carried out individually with composite manufacturers. All interviews have been carried out following the production line visit. Each interview result covers: the company profile, showcase of the manufacturing process captured through STAN2 software as well as summarises the material inputs and outputs through the process.

4.1. Company 1

4.1.1. Company profile

First surveyed company is small scale, low volume aerospace industry parts manufacturer based in the UK. Low volume means that they produce one or two pieces of the same product at the time. The main importance for the final product is quality and compliance with the health and safety requirements.

4.1.2. Process specification

Company is using several manufacturing processes depending on the part that is being produced. For the workshop Automated Tape Lay-up (ATL) process has been selected as it is considered the most wasteful manufacturing process in operation.

4.1.3. Material specification

ATL process selected for the mapping uses pre-preg carbon fibre (CF) that can be specified as material that consists of unidirectional carbon fibre (CF) and an epoxy resin matrix.

4.1.4. The manufacturing process mapping

The STAN 2 map summarises the ATL process that the company uses. The manufacturing process consists of 10 activities: storing, material set-up in the ATL machine, automated tape laying, debulking, part removal, bagging, autoclave running, resin extraction, curing and machining (demonstrated in Graph 1). Table 4 demonstrates all types of waste produced during the manufacturing process. The activities that produce significant amounts of waste are: automated tape laying, where offcuts from pre-preg are produced and curing, where trimming is a main waste source, 22.5% and 5% of the pre-preg scrap in relation to the total amount of material (TAM) used in the manufacturing process. Other waste is created due to curing mistakes and machining processes and is estimated around 0.5% to total material used in production. The finished product represents 72% of TAM used in production (Table 4).

Waste management improvement scope through the outlook questions.

I. What would you change in this process?

The improvement areas were identified in removing or improving autoclave or combining technologies for better results. Also, the company considers looking at changing the process to Automated Fibre Placement which provides comparable results but can achieve up to 1/3 less waste from production.

II. What Scrap has reuse potential? In which industry?

Cured material can be grinded and reused in the construction industry.

If fibres could be extracted, it could be reused to produce non-primary structures.

III. What scrap/waste do you think could be easily reduced? How?

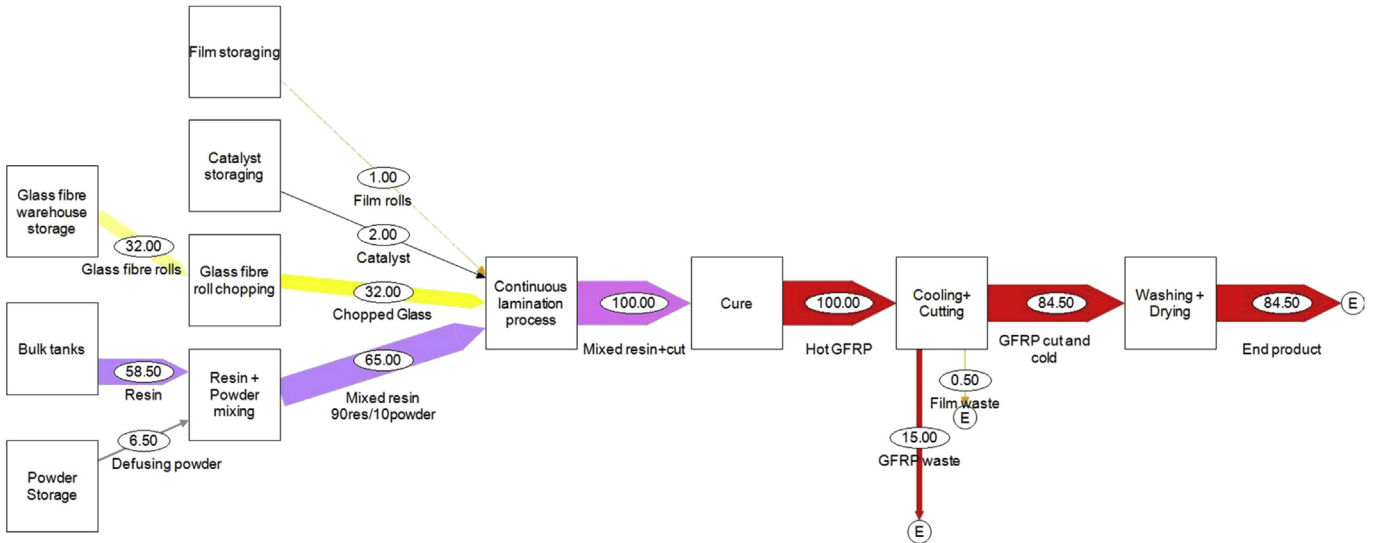

Graph 2. Company 2 material flow analysis (generated with STAN2 software); (I –Input, E-material output).

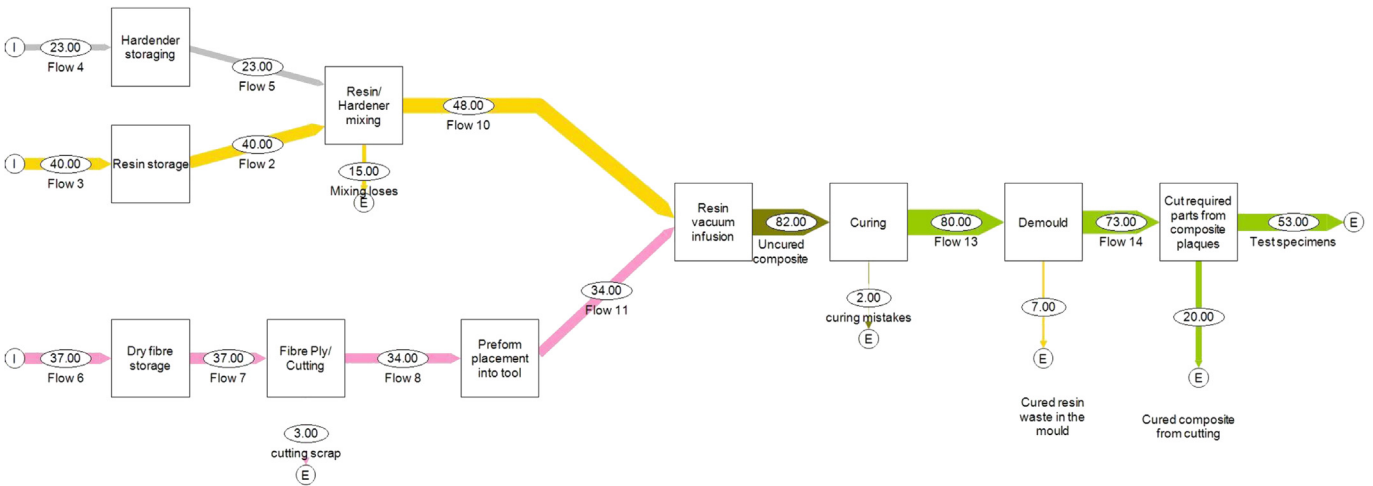

Graph 3. Company 3 material flow analysis (generated with STAN2 software); (I –Input, E-material output).

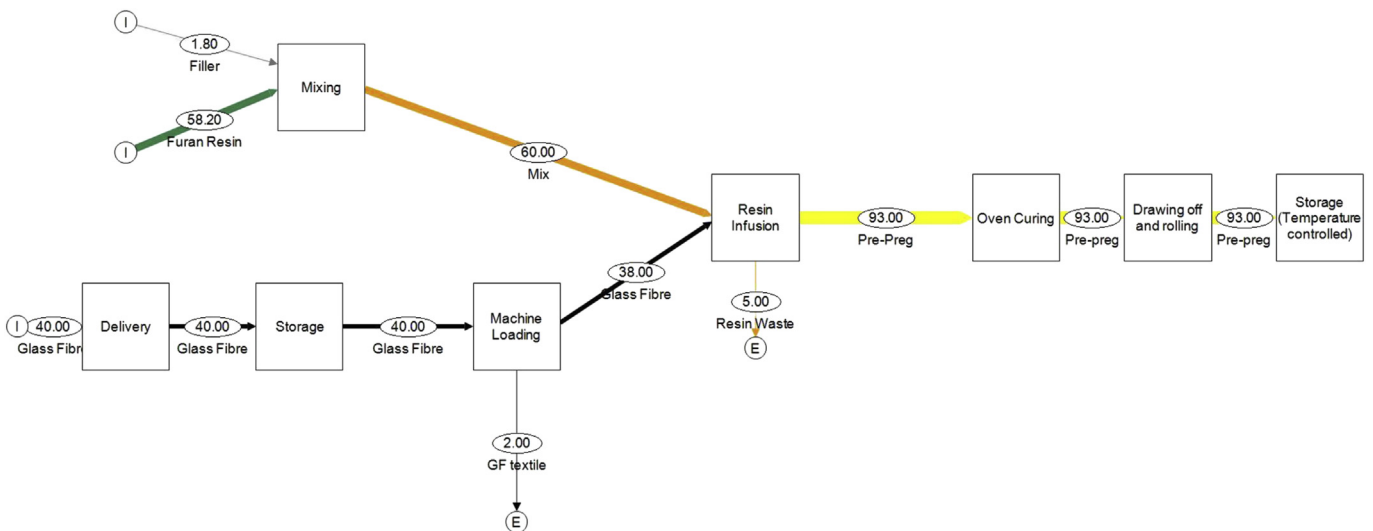

Graph 4. Company 4 material flow analysis (generated with STAN2 software); (I –Input, E-material output).

Table 4
Material input to the manufacturing process for Company 1.

Material	Composition	Activity	Percentage of material utilised	Destination
Pre-preg	65% CF 35% Epoxy resin	ATL scrap	22.5%	Landfill
Non-uniformly cured pre-preg	65%CF 35% Epoxy resin	Curing mistakes	0.25%	Landfill
Cured pre-preg	65%CF 35% Epoxy resin	Cutting (Trimming)	5%	Landfill
Cured pre-preg	65%CF 35% Epoxy resin	Machining	0.25%	Landfill
Cured Pre-preg –	65%CF 35% Epoxy resin	Finished product	72%	Shipping
Total			100%	

As the scrap from the ATL is clean non-cured prepreg, it could be used as reinforcement in hand lay-up processes or as virgin fibre in bulk moulding compound or SMC.

IV. What innovation do you think should happen?

Two innovation areas were identified: autoclave multifunction and parallel production capabilities and automation of simple parts making.

4.2. Company 2

4.2.1. Company profile

Company 2 is a small scale, medium volume roof solution provider for commercial facilities. Most of the products manufactured are standard however the company has flexibility in the production capability to deliver bespoke solutions. The company is a subsidiary of a USA company with rights to manufacture in the UK. The company objective is for the products to comply with roofing regulations and ability to deliver volume of products in ‘just in time’ production set-up.

4.2.2. Process specification

The manufacturing process used has been developed in the USA and is protected by Intellectual Property rights.

4.2.3. Material specification

Materials used in the production process are glass fibre and polyester resin matrix.

4.2.4. The manufacturing process mapping

Within Company 2’s manufacturing process the mixing of material is included as a part of the operation. The main manufacturing operation consists of six steps: storage, mixing, laminating, curing, cooling and cutting, washing and drying. The most wasteful process in cutting operation that consists of off-cuts of the newly made

composites and this scrap is recycled through grinding and incorporation into a new material application. That waste accounts for 15% of the TAM used in production. Additional waste identified was the film used as a part the production process. This waste accounts for 0.5% of production waste and is disposed of. The finished product represents 84.5% of TAM used in production (Table 5).

Waste management improvement scope through the outlook questions.

I. What would you change in this process?

The company focus is on reducing the energy consumption of the process and due to that direction energy efficiency is their next strategic focus.

II. What Scrap has reuse potential? In which industry?

The company feels that there is a lot of potential in the scrap produced.

One example explored by the company currently is DMC/SMC modelling for low aesthetic products – i.e. pipes, underground tanks.

III. What scrap/waste do you think could be easily reduced? How?

The company has already reduced the scrap production technically. The belief is that the education of technical staff operating the line can deliver further progression in scrap reduction. Current focus is on the optimal amount of resin used in production as well as setting-up to minimise rejects.

IV. What innovation do you think should happen?

The company feels that bio-resins is a potential replacement for the standards resins used.

Table 5
Material input to the manufacturing process for Company 2.

Output material	Composition	Description	Percentage of material utilised	Destination
GFRP scrap	6.50% Light diffuser 58.50% Polyester resin 32% GF 2% Catalyst 1% Polyester film	Side cutting scrap	15%	Grinding and reuse
Film Waste	Polyester film	Bottom Layer removal	0.5%	Landfill
GFRP sheet	6.50% Light diffuser 58.50% Polyester resin 32% GF 2% Catalyst 0.5% Polyester film	Finished product	84.5%	Shipping
Total			100%	

Table 6
Material input to the manufacturing process for Company 3.

Output material	Composition	Description	Percentage of material utilised	Destination
Resin + Hardener	33%Hardener 66%Epoxy	Mixing loses	15%	Cured and landfilled
Dry fibre	100%CF	Ply cutting	3%	Recycling
Uncured CF composite	45% CF 55%Epoxy	Curing mistakes	2%	Hazardous material disposal
Cured Resin	33%Hardener 66%Epoxy	Resin waste in the mould	7%	Landfill
Cured CF Composite	45% CF 55%Epoxy	Cutting scrap	20%	Recycled
Cured CF Composite	45% CF 55%Epoxy	Finished Product (Test specimens)	53%	Use in the lab
Total			100%	

4.3. Company 3

4.3.1. Company profile

Third company is a small research and development facility that deals with composite material production and components prototyping based in the UK. Main focus for the facility is to deliver products that meet the design specification and testing materials to comply with various requirements varying from project to project.

4.3.2. Process specification

Process selected for the activity was composite part manufacturing with inclusion of material manufacturing.

4.3.3. Material specification

Materials used in the process are carbon fibre and epoxy resin.

4.3.4. The manufacturing process mapping

The manufacturing process is described into the following steps: Storage (of hardener, resin and dry carbon fibres), resin and hardener mixing, fibre cutting, placement into the tool, infusion, curing, remoulding, cutting the part to specification, and testing. In terms of waste outputs there is mixing losses of around 15% in the scale of the TAM used when the resin and hardener balance is performed, fibre cutting produces dry fibre scrap that accounts for 3%, curing process on average accounts for 2%, resin waste from the moulding process accounts for 7% and cutting scrap from part shaping accounts for 20% of TAM in the manufacturing process. The finished product represents 53% of TAM used in production (Table 6).

The company has provided no answers to the outlook questions that aimed to explore waste management improvement scope.

4.4. Company 4

4.4.1. Company profile

This company is a research and development facility specialising in composite materials science, producing materials and components for testing and proof of concept based in the UK. The company produces not only glass and carbon fibre based composites but also bio-composites.

Table 7
Material input to the manufacturing process for Company 4.

Output material	Composition	Description	Percentage of material utilised	Destination
Glass Fibre	Dry Glass Fibre	Losses in machine loading	2%	Dry fibre waste- landfill
Resin waste	Resin/filler mix 60% Glass Fibre 40%	Resin waste from infusions process	5%	landfill
Glass fibre	Resin/filler mix 60%/GF 40%	Finished product	93%	Shipping
Total			100%	

4.4.2. Process specification

The process selected was glass fibre pre-preg manufacturing process.

4.4.3. Material specification

The process uses dry glass fibre and unspecified resin with fillers.

4.4.4. The manufacturing process mapping

The manufacturing process in making the glass fibre material roll takes the following steps: storage, mixing of resin and filler, machine loading, resin infusion, oven curing, drawing and rolling and storage in the controlled temperature before shipping. The main waste sources have been identified during machine loading where dry glass fibre is fitted; and resin waste from infusion. Dry fibre waste is estimated to be 2% and resin waste 3% of TAM. The finished product represents 93% of TAM used in production (Table 7).

Waste management improvement scope through the outlook questions.

I. What would you change in this process?

The company would want to smooth the process to make it more continuous to get better results and less waste.

II. What Scrap has reuse potential? In which industry?

Recycling short fibres into textiles.

III. What scrap/waste do you think could be easily reduced? How?

No answer provided.

IV. What innovation do you think should happen?

More efficient ovens would minimise significantly energy consumption.

Table 8
Waste management profiles summary of the 4 companies surveyed.

Company no.	Sector	Scale	Total Amount Material (TAM) of production waste in percentage	Current waste management practice
1	Aerospace R&D	Small	27%	Landfill
2	Roofing	Medium	15.5%	Recycling back into manufacturing process
3	Composites R&D	Small	46%	Landfill
4	Composites R&D	Small	7%	Landfill

Table 9
Fibre related scrap production summary.

Company	Dry fibre	Sheet off cuts	Cured composite	Resin waste	Production scale
1	0%	22.5%	5.5%	0%	Small
2	0%	0%	15%	0%	Medium
3	3%	2%	20%	22%	Small
4	2%	0%	0%	5%	Small

Stop start production system would allow more control over the production run in comparison to the continuous runs.

5. Discussions

The research methodology has assumed that the workshop is going to be performed at as many organisations willing to participate as possible. However the interest in composites recycling has been very small. Table 8 summarises the data gathered about the four companies that undertook the full research procedure. Only company number 2 has actually operated on the scaled up production levels and it has a record of being engaged in the recycling activities. The remaining three organisations combine research and production and produce smaller numbers of products. Due to the diversity of the four companies representing different industries that have taken part in this study, it is not possible to associate the waste stream production to any particular industry or particular process. However, the chosen methodology allows us to point out and specify types of waste created in the individual manufacturing processes.

Through the research it has been clear that although the exercise allows capturing the percentage of the material used in the production it only suggests the efficiency of the production line itself. However, the data collected does not indicate the actual amount of material that is wasted and does not provide an idea of volume. This has been done to comply with the organisations

confidentiality rules however for individual organisations using the tool in house it is achievable. For the purpose of this paper establishing the scale of operation is a vital element to understanding the potential benefits of looking at alternative waste management routes other than recycling (Table 8). Although companies 1 and 3 could improve their material efficiency, the scale of their manufacturing operation is too small for recycling to be viable; however potential for reuse of the material is feasible. For instance, consideration should be given to looking at feeding waste for recycling as a part of a social corporate responsibility strategy. As they produce a maximum of 100 products they are not gaining additional benefits from recycling itself. Furthermore, the main objective of their activities is focused on research purpose product development (delivering product to specification) but not on achieving the production efficiency. Company 2 on the other hand is in commercial operation and is concerned with volume and manufacturing process optimisation. As it is a commercial operation reduction of waste becomes part of the operational targets which allows considering recycling as a feasible business extension.

The type of waste materials produced from manufacturing can be characterised through identification of the stage of composite manufacturing production it has occurred. Under the assumption that fibres are the most valuable material to treat three types of fibre waste outputs have been identified: dry fibre, composite material roll or the composite product (shaped product). The dry fibres are common waste in case of pre-preg or woven material production, while waste cured composite waste is usually from cutting and trimming activities where composite products are made. Process flow tools allow clarification of the waste stream material characteristics as well as capturing the volumes of different waste outputs created. Table 9 summarises the fibre related waste output from all four companies. It can be seen that company 4, who produce only material sheet, provide dry glass fibre and resin waste outputs. Those are very low outputs and they are separated from each other. As this waste is heterogonous its reuse potential is higher than companies 1, 2 and 3. Nonetheless,

Table 10
Recycled composite material applications reported by previous research, (Job (2010), Witik et al. (2013), Zeng et al. (2009), Meira Castro (2013), Palmer et al. (2009), Asokan et al. (2009), Fauziah et al. (2012), Wong et al. (2010), Palmer et al. (2010), Howarth and Jeschke (2009), Pickering (2006).

Material type	Waste type	Recycling process available	Output	Application	Application source
Glass fibre	Cured composite	Mechanical Grinding	Powdered glass reinforced plastics	SMC/DMC in automotive sector (i.e. radiator brackets)	Job (2010)
			Two size grades of milled GFRP waste	Reinforcing material for polymer based mortars	Meira Castro (2013)
		Fluidised bed process (glass fibres from non-metal materials of waste PCBs) Not known	Ground SMC recycle Glass fibre	DMC compound Non-specified	Palmer et al. (2009) Zeng et al. (2009)
Carbon fibre	Cured composite	Fluidised bed	E-glass waste Fibres	Reinforcing agent in soil Electromagnetic interference (EMI) shielding material	Fauziah et al. (2012) Wong (2012)
		Pyrolysis	Short fibres	Automotive SMCs, PEM fuel cell materials, EMI shielding components	Howarth and Jeschke (2009)
Cured resin		Mechanical Grinding Incineration with energy recovery	Fibres and powder Energy	SMC compound Energy source	Palmer et al. (2010) Pickering (2006)

Table 11
Unit process energies of composite recycling.

Recycling process	Process energy (MJ/kg)
Mechanical Grinding	5.97–6.77 ^a
Milling	0.27–2.03 ^b
Pyrolysis	30 ^c
Fluidised Bed	Unknown

^a Srivastava et al., 2012.

^b Howarth et al., 2014.

^c Witik et al., 2013.

company 3 who produces material and product in one process can reuse dry fibres and resin waste but cut-offs from infused sheets and carried composite waste have recycling potential. Companies 1 and 2 can look into recycling as means of treating the cut-offs from infused sheets and cured composite waste.

Table 10 demonstrates applications of recycled cured composites that have already been reported through different research. Reincorporating carbon fibre reinforced plastics (CFRP) and glass fibre reinforced plastics (GFRP) into a different range of products in a form of fibre or powder (where resin and powder mix is used) has been demonstrated in construction, products for automotive, electronics and SMC manufacturing. Although these examples are reported on the research scale, they prove the feasibility of waste composites incorporation in new product applications. The table also shows the recycling process used in material transformation which demonstrates versatility potential in applications as well as the processes available to be used.

In order to evaluate the usefulness of applications Table 11 illustrates the unit process energy of typical composite recycling processes. Considering that the embodied for virgin glass fibre is estimated to be 13–32 MJ/kg and that of virgin carbon fibre 183–286 MJ/kg (Song et al., 2009), it is clear that there are large potential energy savings in utilising recycle fibres in place of virgin ones in the applications mentioned in Table 10.

6. Conclusions

This paper aimed to demonstrate the waste from manufacturing process capture and provide characterisation of types of waste in the point of scrap creation. The paper demonstrated a method of systematic data gathering of composite waste from manufacturing. Although similar process and material mapping has been done before the novelty of the paper is utilisation of existing methods to realise material treatment diversification potential for the waste management of composites. This research not only highlighted the points of scrap generation (to aid waste minimisation), but in collating data on type and amount of scrap, which can inform decisions on recycling technology development. Through the case studies it has been identified that there are three fibre related waste outputs captured: dry fibres, fibre material sheet off-cuts, and cured composite off-cuts. Also, material composition is able to be captured through the tool. The captured information allows for the material specification development. This allows bridging the gap between the manufacturers and the waste processors in composites to address the lack of infrastructure and lack of waste material specification barriers outlined by the Composites Strategy 2009.

The technique also demonstrates straightforward in-house waste management for manufacturing processes. Monitoring and management for both minimisations of waste and selection of appropriate downstream processing of composite waste can be achieved through the application of methodology used in this research. And thus wider adoption of the methodology could help

in reducing the manufacturing waste generated by the industry, and of course bring the environmental and economic benefits.

Further work within this area could focus on either widening the scope of the process mapping to multiple companies from diverse industries to understand the potential scope of minimisation of waste. Additionally other research can focus on linking the current process mapping of manufacturing processes to develop waste minimisation potential benchmarking to industry or legislation requirements.

Acknowledgements

The authors of this paper would like to thank the EPSRC funding body for funding this research as a part of the Efficient X-sector use of heterogeneous materials in manufacturing -EXHUME Project (under grant EP/K026348/1).

References

- Ahmad, F., Mujah, D., Hazarika, H., Safari, A., 2012. Assessing the potential reuse of recycled glass fibre in problematic soil applications. *J. Clean. Prod.* 35, 302–307.
- Aguilar-Savén, R.S., 2004. Business process modelling: review and framework. *Int. J. Prod. Econ.* 90 (2), 129–149.
- Asokan, P., Osmani, M., Price, D.F., 2009. Assessing the recycling potential of glass fibre reinforced plastics waste in concrete and cement composites. *J. Clean. Prod.* 17 (9), 821–829.
- BIS, 2013. Lifting Off: Implementing the Strategic Vision for UK Aerospace. HM Government, BIS.
- Bolin, C.A., Smith, S., 2011. Life cycle assessment of ACQ-treated lumber with comparison to wood plastic composite decking. *J. Clean. Prod.* 19 (6–7), 620–629.
- Brunner, P.H., Rechberger, H., 2004. *Practical Handbook of Material Flow Analysis*, first ed. Lewis, New York.
- Burmeister, L., Clark, A., Gonzalez, A., Greenfield, A., 2010. *Unlocking the Value: Transforming the Connecticut Materials Economy*. Yale University School of Forestry and Environmental Studies Department.
- Conroy, A., Halliwell, S., Reynolds, T., 2006. Composite recycling in the construction industry. *Compos. Part A: Appl. Sci. Manuf.* 37 (8), 1216–1222.
- Council directive 2008/98/EC (Waste Framework Directive).
- Cencic, O., Rechberger, H., 2008. Material flow analysis with software STAN. *J. Environ. Eng. Manag.* 18 (1), 3–7.
- Ernst and Young, 2010. UK Composites Supply Chain Scoping Study – Key Findings. UKTI & BIS.
- European Commission, 1999. Directive 1999/31/EC of the European Parliament and of the Council of 26 April 1999 on Landfill of Waste. Official Publications of the European Communities, Luxembourg.
- European Commission, 2000a. Directive 2000/76/EC of the European Parliament and of the Council of 4 December 2000 on the Incineration of Waste. Official Publications of the European Communities, Luxembourg.
- European Commission, 2000b. Directive 2000/53/EC of the European Parliament and of the Council of 18 September 2000 on End-of-Life Vehicles. Official Publications of the European Communities, Luxembourg.
- Fauziah, A., Donovan, M., Hemanta, H., Aboufazel, S., 2012. Assessing the potential reuse of recycled glass fibre in problematic soil applications. *J. Clean. Prod.* 35, 102–107.
- Fawaz, A.A., Rajgopal, J., 2007. Analyzing the benefits of lean manufacturing and value stream mapping via simulation: a process sector case study. *Int. J. Prod. Econ.* 107, 223–236.
- Howarth, J., Jeschke, M., 2009. Advanced nonwoven materials from recycled carbon fibre. In: *Carbon Fibre Recycling and Reuse 2009 Conference*, Intertech Pira, Hamburg, Germany.
- Howarth, J., Mareddy, S.S.R., Mativenga, P.T., 2014. Energy intensity and environmental analysis of mechanical recycling of carbon fibre composite. *J. Clean. Prod.* 81, 46–50.
- Jiang, G., Pickering, S.J., Walker, G.S., Bowering, N., Wong, K.H., Rudd, C.D., 2007. Soft ionisation analysis of evolved gas for oxidative decomposition of an epoxyresin/carbon fibre composite. *Thermochim. Acta* 454, 109–115.
- Job, S., 2009. *The UK Carbon Fibre Composites Industry*. NetComposites, Chesterfield.
- Job, J., 2010. *Composite Recycling, Summary of Recent Research and Development*. Materials KTN.
- Kahlat, R., Williams, E., 2012. Materials flow analysis of e-waste: domestic flows and exports of used computers from the United States. *Resour. Conservat. Recycl.* 67, 67–74.
- Miliutenko, S., Bjorklund, A.Q., Carlsson, A., 2013. Opportunities for environmentally improved asphalt recycling: the example of Sweden. *J. Clean. Prod.* 43, 156–165.
- Meira Castro, A.C., Riberio, M.C.S., Santos, J., Meixedo, J.P., Silva, F.J.G., Fiuza, A., Dinis, M.R., Alvim, M.R., August 2013. Sustainable waste recycling solution for

- glass fibre reinforced polymer composite materials industry. *Constr. Build. Mater.* 45, 87–94.
- Morin, C., Loppinet-Serani, A., Cansell, F., Aymonier, C., 2012. Near- and supercritical solvolysis of carbon fibre reinforced polymers (CFRPs) for recycling carbon fibres as a valuable resource: state of the art. *J. Supercrit. Fluids* 66, 232–240.
- Mouzon, G., Yildirim, M.B., Twomey, J., 2007. Operational methods for minimization of energy consumption of manufacturing equipment. *Int. J. Clean. Prod.* 45 (18–19), 4247–4271.
- Palmer, J., Ghita, O.R., Savage, L., Evans, K.E., 2009. Successful closed-loop recycling of thermoset composites. *Compos. Part A* 40, 490–498.
- Palmer, J., Savage, L., Ghita, O.R., Evans, K.E., 2010. Sheet moulding compound (SMC) from carbon fibre recycle. *Compos. Part A: Appl. Sci. Manuf.* 41 (9), 1232–1237.
- Pickering, S.J., 2006. Recycling technologies for thermoset composite materials—current status. *Compos. Part A: Appl. Sci. Manuf.* 37 (8), 1206–1215.
- Rahani, A.L., Al-Ashraf, M., 2012. Production flow analysis through value stream mapping: a lean manufacturing process case study. *Procedia Eng.* 41, 1727–1734.
- Roberts, T., 2009. *The Carbon Fibre Industry Worldwide 2008–2014: an Evaluation of Current Markets and Future Supply and Demand*. Materials Technology Publications, Watford.
- Smith, F., Sims, G., Hogg, P.J., Hooper, A., Kapadia, A., Quarshire, R., 2012. *Technology Needs to Support Advanced Composites in the UK*, The Inter-Agency Composites Group report.
- Smith, L., Ball, P., Nov 2012. Steps towards sustainable manufacturing through modelling material, energy and waste flows. *Int. J. Clean. Prod.* 140, 227–238.
- Song, Y.S., Youn, J.R., Gutowski, T.G., 2009. Life cycle energy analysis of fiber-reinforced composites. *Compos. Part A* 40, 1257–1265.
- Srivastava, A., Bull, S., Ord, G., 2012. Application of mechanically recycled waste material: glass fibre reinforced plastic (GFRP). In: *Proceedings of Composites Engineering Conference 2012*. NetComposites, Birmingham, UK, pp. 90–101.
- Vinodh, S., Arvind, K.R., Somanaathan, M., 2010. Application of value stream mapping in an Indian camshaft manufacturing organisation. *J. Manuf. Technol. Manag.* 21 (7), 888–900.
- Witik, R.A., Teuscher, R., Michaud, V., Ludwig, C., Manson, J.A., 2013. Carbon fibre reinforced composite waste: an environmental assessment of recycling, energy recovery and landfilling. *Compos. Part A* 49, 89–99.
- Wong, K.H., Pickering, S.J., Rudd, C.D., 2010. Recycled carbon fibre reinforced polymer composite for electromagnetic interference shielding. *Compos. Part A: Appl. Sci. Manuf.* 41 (6), 693–702.
- WRAP, 2013. *Developing a Resource Efficiency Action Plan for the Composites Sector*, Scoping Study. WRAP: PRD106–105.
- Yang, Y., Boom, R., Irion, B., van Heerden, D.-J., Kuiper, P., de Wit, H., 2012. Recycling of composite materials. *Chem. Eng. Process. Process Intensif.* 51, 53–68.
- Zheng, Y., Shen, Z., Ma, S., Cai, C., Zhao, X., Xing, Y., 2009. A novel approach to recycling of glass fibers from nonmetal materials of waste printed circuit boards. *J. Hazard. Mater.* 170 (2–3), 978–982.