

Single camera 3D planar Doppler velocity measurements using imaging fibre bundles

T O H Charrett, H D Ford and R P Tatam

Optical Sensors Group, Centre for Photonics and Optical Engineering, School of Engineering, Cranfield University, Cranfield, Bedford, MK43 0AL, UK.

E-mail: r.p.tatam@cranfield.ac.uk

Abstract. Two frequency planar Doppler Velocimetry (2v-PDV) is a modification of the Planar Doppler Velocimetry (PDV) method that allows velocity measurements to be made, quickly and non intrusively, across a plane defined by a laser light sheet. In 2v-PDV the flow is illuminated sequentially with two optical frequencies, separated by about 700MHz. A single CCD viewing through an iodine absorption cell is used to capture images under each illumination. The two images are used to find the normalised transmission through the cell, and the velocity information is encoded as a variation in the transmission. Use of a single camera ensures registration of the reference and signal images and removes issues associated with the polarization sensitivity of the beam splitter, which are major problems in the conventional approach. A 2v-PDV system has been constructed using a continuous-wave Argon ion laser combined with multiple imaging fibre bundles, to port multiple views of the measurement plane to a CCD camera, allowing the measurement of three velocity components.

1. Introduction

Planar Doppler Velocimetry (PDV)[1-3], also known as Doppler Global Velocimetry (DGV),[4] is a flow measurement technique that provides velocity information over a plane defined by a laser light sheet. PDV relies upon measuring the Doppler frequency shift of light scattered from particles entrained in the flow. As PDV relies upon the Doppler shift a single observation direction can measure a single component of velocity, as shown in figure 1. The use of imaging fibre bundles[5] allows several observation directions, and thus velocity components, to be measured simultaneously on different portions of the CCD. The optical frequency shift, $\Delta\nu$, is given by the Doppler equation:

$$\Delta\nu = \frac{\nu(\hat{\boldsymbol{o}} - \hat{\boldsymbol{i}}) \cdot \boldsymbol{V}}{c} \quad (1)$$

where ν is the optical frequency, $\hat{\boldsymbol{o}}$ and $\hat{\boldsymbol{i}}$ are unit vectors in the observation and illumination directions respectively, \boldsymbol{V} is the velocity vector and c is the free space speed of light. The light scattered from each particle in the seeded flow experiences a Doppler frequency shift, which is linearly related to the velocity of the particle at that point in the flow. In PDV, a region of the illuminated flow is imaged, through a glass cell containing iodine vapour, onto the active area of a CCD camera. Iodine has numerous narrow absorption lines over a large part of the visible spectrum[6]. If the laser frequency is chosen to coincide with one such line, the optical intensity at any

position in the camera image is a function of the Doppler shift experienced at the corresponding flow position, via the frequency-dependent iodine absorption.

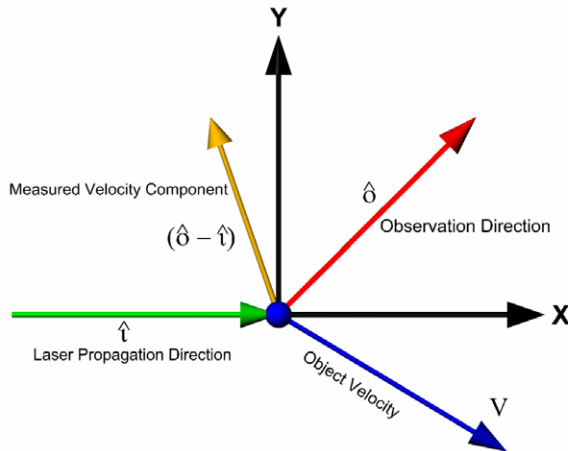

Figure 1. The relationship of laser illumination direction and observation direction to the measured velocity component determined from the Doppler equation.

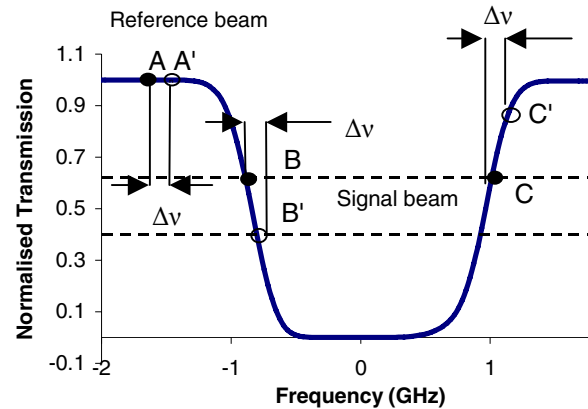

Figure 2. Relative positions of the laser frequency, and the shifted frequency on a typical absorption feature for 2v-PDV (A and B/C denote the position of the illumination frequencies and A' and B'/C' the Doppler shifted frequency.)

The intensity over a PDV image is affected by the intensity profile of the illuminating laser sheet (typically Gaussian), spatial variations of the seeding density within the flow, and diffraction fringes caused by imperfections in the optical surfaces. These variations are generally of similar amplitude to those resulting from absorption in the iodine cell, and can obscure the information about flow velocity that is contained within the camera image. It is therefore usual to amplitude-divide the image beam onto two cameras; from one of the two imaging paths the iodine cell is omitted, and the resulting image acts as a reference to normalize the signal image carrying the velocity information. In the two-frequency planar Doppler velocimetry (2v-PDV)[7] technique the signal and reference images are acquired on the same CCD camera by the use of two illumination frequencies.

The emission wavelength of the laser is tuned just off the low frequency side of an absorption line. The output beam is first frequency up shifted to lie in a zero absorption region of the iodine transfer function (figure 2, point A). A reference image is then acquired. The frequency is then downshifted to lie approximately midway (50%) on the iodine cell transfer function (figure 2, point B), and a signal image is acquired. The optical frequency difference is $\sim 700\text{MHz}$, which is sufficiently small that there will be no change in the scattering for the size of particles typically used; $0.2\text{-}5\ \mu\text{m}$ diameter. Exact alignment of the reference and signal images on the active area of the camera is automatic. The method also eliminates the polarization sensitivity of the split ratio of the beam splitter used in two-camera systems.

Conventionally to obtain 3D measurements three separate detector heads, containing in total six CCD cameras and three iodine cells, are required. The use of coherent optical fibre imaging bundles, described in section 3, combined with the two-frequency technique reduces this to a single CCD camera and iodine cell.

2. Single velocity component measurements

Initially the system was setup to measure a single velocity component as shown in figure 3. A continuous wave argon ion laser was used as the light source, allowing time averaged velocity measurements to be made. The optical frequency of this source was altered to form the reference and signal beams using a combination of two acousto-optic modulators (AOM). The generation of both the

reference beam and the signal beam is shown in the detail of the two-frequency beam generator. The signal beam is generated when AOM 1 is switched on and AOM 2 is switched off, providing an up-shift of 520MHz. When AOM 2 is on and AOM 1 off the reference beam is generated with a 180MHz downshift in frequency.

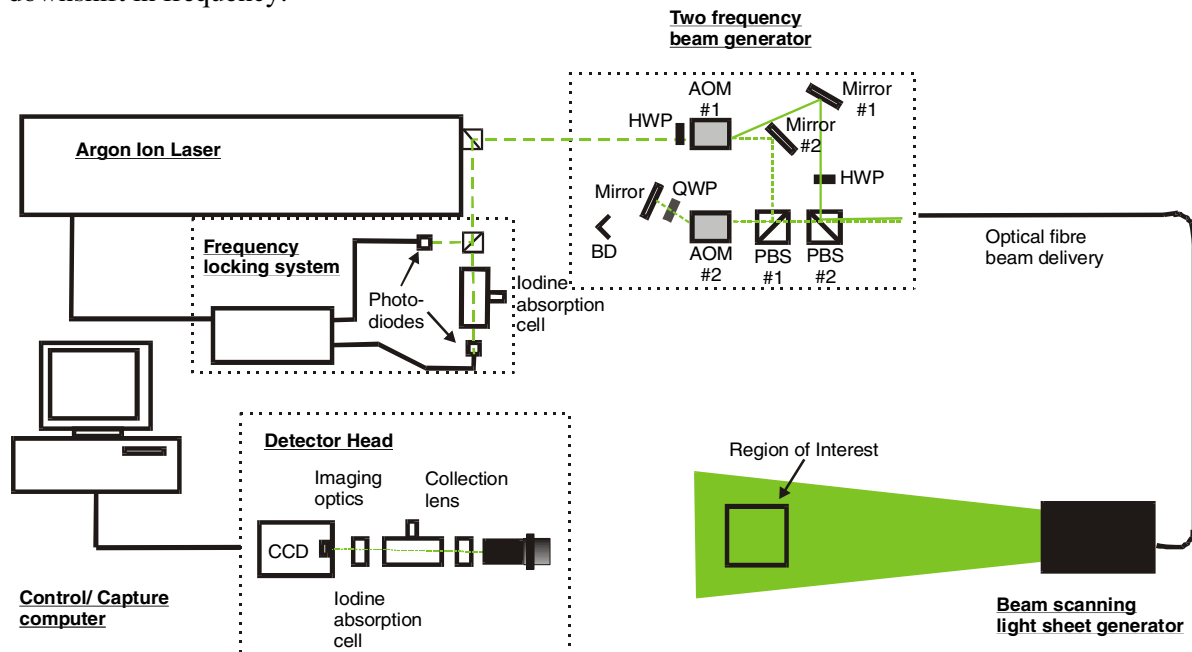

Figure 3. Schematic of the experimental arrangement for the single component measurements including detail of the two-frequency beam generator showing the generation of both the signal and reference beams.

HWP - $\lambda/2$ plate; AOM – acousto-optic modulator; PBS – polarising beam splitter, QWP – $\lambda/4$ plate; BD – beam dump. — Reference beam path Signal beam path - - - Un-shifted laser beam

Both beams leave the beam generator and are coupled into an optical fibre. The beams are then delivered to a prism-scanning device[8]. This scans the collimated beam rapidly across the region of interest, resulting in an ideal 'top-hat' intensity profile of the generated light sheet. The desired illumination frequency can then be selected by toggling on/off the two AOMs.

A frequency locking system is used to control the laser's fundamental frequency, and hence the positions of the two beams on the iodine absorption line. This consists of an iodine cell, signal and reference photodiodes and locking electronics which adjusts the laser etalon temperature to ensure that the laser frequency is stable, based upon the transmission through this cell.

The detector head images the region of interest in the flow using a standard SLR camera lens and a signal image and a reference image are captured under the appropriate illumination selected by toggled the AOMs on/off. It was then demonstrated on a seeded air jet to provide conditions similar to the techniques intended applications on seeded airflows. The jet used was an axis-symmetric air jet, with a 20mm diameter smooth contraction nozzle that was seeded using a smoke generator producing seed particles in the 0.2-0.3 μm diameter range. The jet has a theoretical exit velocity of 94 ms^{-1} , which was calculated by measuring the nozzle pressure ratio. The Figure 4 shows the main velocity component of this jet at various positions from the nozzle[7] and figure 5 show profiles taken through the centre of each slice compared with the theoretical velocity profile for the jet.

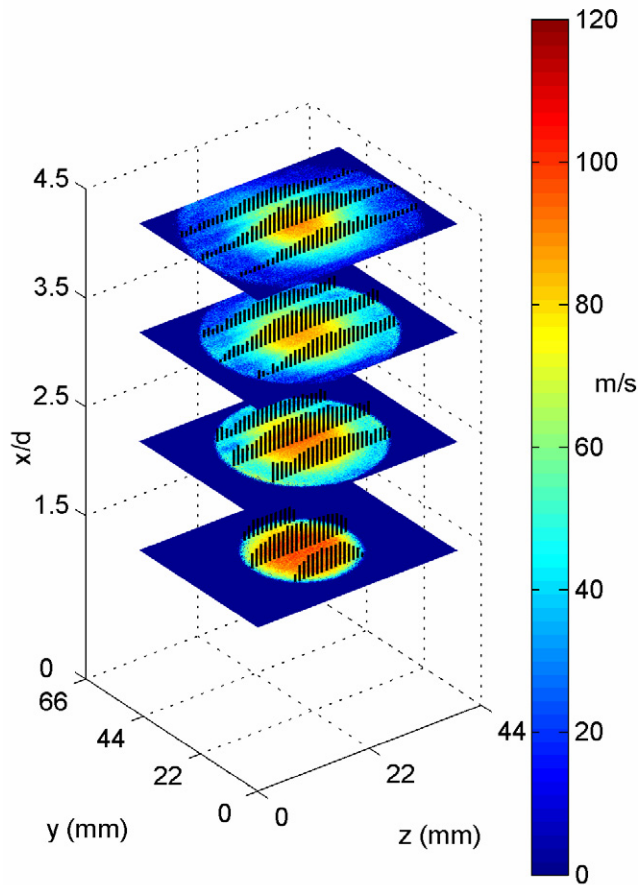

Figure 4. The velocity field of an axisymmetric air jet made using 2v-PDV. Measurements were taken at 1.5, 2.5, 3.5 and 4.5 nozzle diameters downstream from the nozzle. Overlaid are vectors showing the magnitude of the velocity at various points (arrow heads have been removed for clarity)

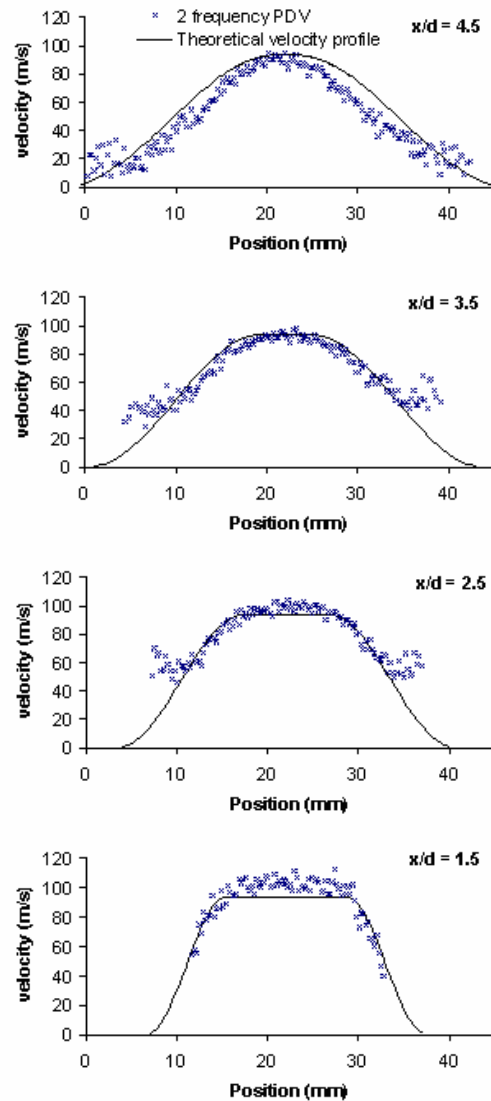

Figure 5. Profiles taken through the center of each slice, (crosses – experimental values, solid – theoretical velocity profile)

3. Three dimensional velocity measurements

The system was then extended to measure three velocity components, using the imaging fibre bundles as the input into the detector head. Views of the region of interest are ported to the detector head using a coherent array of fibres that is split into four channels (figure 6). Each channel has 600x500 fibres that are 8 μ m in diameter and positioned at 10 μ m centres. These views are combined at the detector head, with each occupying a quarter of the CCD image (figure 7). An example of the image formed is shown in figure 8. This is a view of a calibration target used to de-warp the views to a common view and determine the observation directions for each view[9]. Figure 9 shows the views after this de-warping process; here all four views have been overlaid for demonstration purposes.



Figure 6. The individual arms of the imaging fibre bundles.

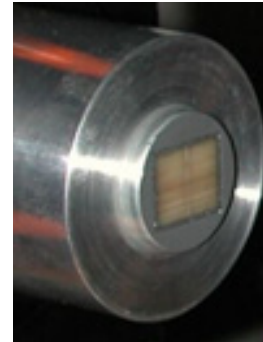

Figure 7. The combined end of the imaging fibre bundles.

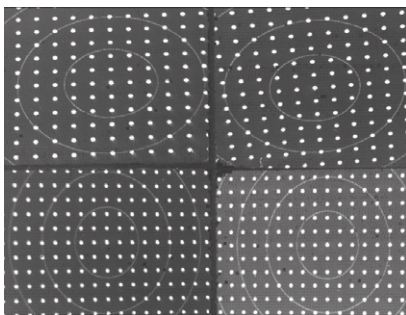

Figure 8. An example image of a view through the imaging bundles of a calibration target (field of view $\sim 100 \times 100$ mm)

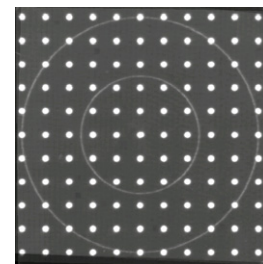

Figure 9. An example of the 'de-warped' views. Showing all four views overlaid

However the arrangement of the beam generator, shown in figure 3, was very light inefficient and combined with the use of the imaging fibre bundles, resulted in low scattered light levels being collected. The experimental arrangement was modified to allow greater illumination power; this new arrangement is shown in figure 10. Here the laser frequency is selected by tuning the laser etalon voltage and is then stabilized using the locking system described above. The frequency of the locking beam is shifted by 260MHz so that the locking system can still operate if the laser is located at 100% transmission. The locking beam will be shifted onto the absorption line so that any frequency fluctuations will result in a transmission fluctuation seen by the photodiodes and can be corrected for. Although this arrangement increased the illumination power the images are now captured with a separation of minutes rather than seconds, although for time average measurements this has not been a problem.

As well as providing increased beam powers, it is now possible to tune both beam frequencies to coincide with the absorption line, one on the falling slope and the other on the rising slope. Using two frequencies tuned to these positions (figure 2, points B and C) can be used to double the sensitivity of the measurement. If one source is tuned onto the falling slope and the other on the rising slope then a constant Doppler shift will result in the further attenuation of one image to a lower signal level and the rise in the signal level in the other image. Dividing the difference of the images by the sum, and taking into account any difference in the gradients will give a result that has approximately double the sensitivity of the current PDV methods.

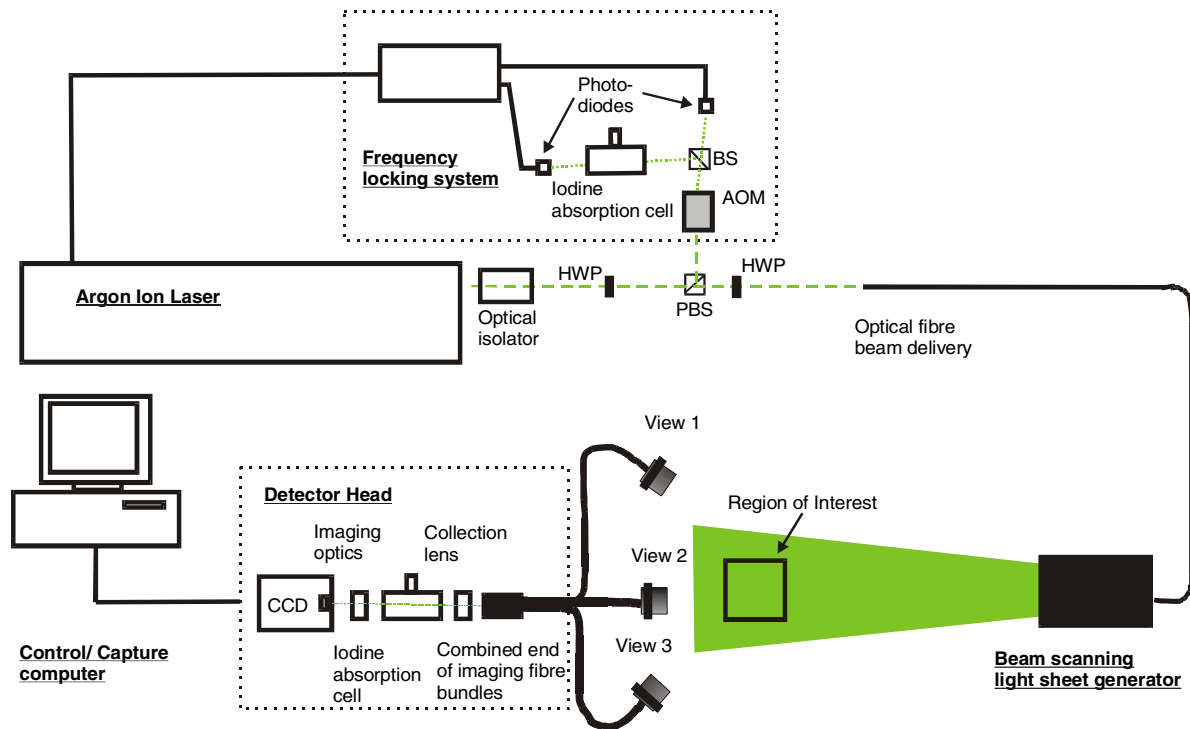

Figure 10. Schematic showing the experimental arrangement used for the three dimensional velocity measurements.

HWP - $\lambda/2$ plate; AOM – acousto-optic modulator; PBS – polarising beam splitter, ----- Shifted (locking) beam path - - - - - Un-shifted (illumination) beam

A further modification to the system was that the multi-mode fibre used in the single component measurements to transport the beams to the light sheet generator, was replaced with a single-mode, polarization-preserving fibre. This was changed to ensure that the spatial profile of both beams remained the same. If these differ significantly, the illumination profiles can also differ, especially when a thick sheet is required, such as when illuminating the face of disc; previously[7] when making single component measurements on the disc it was noted that a 'white card' correction was needed.

The double sensitivity scheme described above was used to measure the velocity field of a rotating disc. This provides a well-known velocity field with which to characterise the performance of the system. Each arm of the imaging fibre bundle was used with a standard SLR camera lens to view the rotating disc. The disc itself was 200mm in diameter, although the common field of view of each observation direction was an approximate disc 100mm in diameter. The rotation of the disc was measured using an optical tachometer giving a maximum velocity in the field of view of $\sim 20\text{ms}^{-1}$. Each of the observation directions was processed through to a velocity component, with the direction given by $(\hat{\theta} - \hat{i})$. An example of a typical component can be seen in figure 11(a). These measured velocity components are then converted to the orthogonal components aligned with the coordinate system of the experiment. Figures 11(b) and (c) show examples of the computed orthogonal velocity components, U and V, with the velocity changing from zero at the centre of the wheel to the maximum magnitude at the edges.

The adoption of a single mode fibre for transporting the beam from the two-frequency beam generator to the sheet forming optics, results in identical signal and reference illumination profiles and there being no need to apply the 'white card' correction to realise the velocity field.

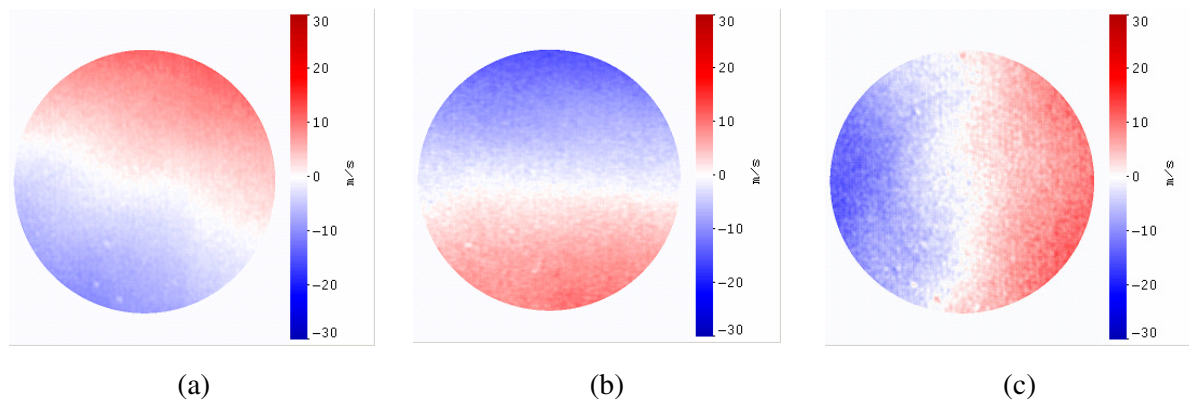

Figure 11. Velocity fields from a rotating disc (a) An example of a processed velocity component. (b) Typical computed horizontal (U) velocity component. (c) Typical computed vertical (V) velocity component.

4. Conclusions

A PDV technique using two illumination frequencies and imaging fibre bundles has been demonstrated that is capable of measuring all three components of velocity, across a plane defined by a light sheet, using a single CCD camera. Single velocity component, time averaged, velocity measurements on a rotating disc and a seeded air jet were made and the pixel-matching problem has been overcome by the use of a single camera. This results in there being no need to use a 'white card' correction commonly applied in PDV measurements.

The potential to expand the system to measure all three components of velocity, using imaging fibre bundles, has been demonstrated by making measurements of a rotating disc. The use of the imaging fibre bundles also allows greater flexibility in the positioning of the observation directions.

Acknowledgements

This work was funded by the Engineering and Physical Sciences Research Council (EPSRC), UK (GR/SO4291).

References

- [1] Komine, H., Brosnan, S., Litton, A., and Staepert, E., 1991, Real-time Doppler global velocimetry, *AIAA 29th Aerospace Sciences Meeting*, (Reno, Nevada), Paper 91-0337.
- [2] Meyers, J.F., Lee, J.W., and Schwartz, R.J., 2001, Characterization of measurement error sources in Doppler global velocimetry, *Measurement Science and Technology*, **12**, 357-368.
- [3] Ford, H.D. and Tatam, R.P., 1997, Development of extended field Doppler velocimetry for turbomachinery applications", *Optics and Lasers in Engineering*, **27**, 675-696.
- [4] Meyers, J.F. and Lee, J.W., 1991, Proof of concept test of the Doppler global velocimeter, *Spaceborne Photonics: Aerospace Applications Of Lasers And Electro-optics*, (Newport Beach, CA).
- [5] Nobes, D.S., Ford, H.D., and Tatam, R.P., 2004, Three component planar Doppler velocimetry using imaging fibre bundles, *Experiments in Fluids*, **36**, 3-10.
- [6] Gerstenkorn, S. and Luc, P., 1986, *Atlas du Spectre d'Absorption de la Molecule d'Iode 14800-200 cm⁻¹ Complement: Identification des Transitions du Systeme (B-X)*. Paris, France: Editions du Centre Nationale de la Recherche Scientifique;
- [7] Charrett, T.O.H., Ford, H.D., Nobes, D.S., and Tatam, R.P., 2004, Two frequency planar Doppler velocimetry, *Review of Scientific Instruments*, **75**, 4487-96.
- [8] Roehle, I., Willert, C., Schodl, R., and Voigt, P., 2000, Recent developments and

applications of quantitative laser light sheet measuring techniques in turbo machinery components, *Measurement Science and Technology*, **11**, 1023-35.

- [9] Nobes, D.S., Wieneke, B., and Tatam, R.P., 2004, Determination of view vectors from image warping mapping functions, *Optical Engineering*, **43**, 407-14.