

An RF Excited Plasma Cathode Electron Beam Gun Design

Sofia del Pozo, Colin Ribton, David R. Smith

A plasma cathode electron beam (EB) gun is presented in this work. A radio frequency (RF) excited plasma at 84 MHz was used as the electron source to produce a beam power of up to 3.2 kW at -60 kV accelerating voltage. The pressure in the plasma chamber is approximately 1 mbar. The electrons are extracted from the plasma chamber to the vacuum chamber (at 10^{-5} mbar) through a diaphragm with a 0.5 mm diameter nozzle. Advantages over thermionic cathode guns were demonstrated empirically. Maintenance costs are reduced, as the cathode does not wear out as quickly during use. RF modulation can be used for controlling the beam power and thus there is no requirement for a grid cup electrode. Rapid (sub 1 microsecond) beam pulsing is achievable. Optical emission spectroscopy has been used to study the plasma parameters that affect the level of beam current.

Introduction

Electron beam (EB) guns have been used for a long time in material processing applications [1]. Welding, electron beam melting for additive manufacturing and surface modification are some examples of applications that require different beam powers and accelerating voltages. Generally, these types of electron guns use a thermionic cathode as the electron source. However, there are some limitations with thermionic cathodes. Firstly, the cathode wears [2] during processing and as a result the beam properties (e.g. intensity and focus position) are changing from the beginning to the end of its life and this introduces degradation of the quality of the processing. Secondly, in conventional guns a third electrode or grid cup is used to control the flow of electrons that form the beam, and this introduces beam aberration [3]. Thirdly, rapid pulsing of the beam requires complex electronics, which can be expensive and prone to failure.

In this work a plasma cathode gun [4] is presented as a solution to the main problems encountered with thermionic guns. Since an ionized gas is used as the electron source instead of a thermionic material, the problems associated with cathode wear are substantially reduced. This allows repeatability for the material processing application from the start to the end. An RF signal is used for the plasma excitation, thus RF amplitude modulation can be used to control beam power without using a grid electrode (i.e. operating the gun as a fast diode) and this enables rapid beam pulsing up to 200 times faster than with thermionic guns.

Optical emission spectroscopy will be used to look at the plasma generated. This is one of the most established techniques in plasma diagnosis providing the possibility to extract information from the plasma in real-time and in a non-intrusive way so that the plasma is not affected [5]. Even though the preliminary results demonstrate that a beam can be extracted from the plasma cathode gun, the beam power is only sufficient for low power material processing applications. Higher power is needed for other applications such as welding of metals. Thus the plasma parameters need to be studied in order to reach the optimum conditions to maximize electron extraction and thereby maximize beam power.

Description of the Electron Gun Design

The electric schematic of the device is illustrated in Figure 1 [6]. It shows an RF inductively coupled circuit with the left hand part of the circuit being the transmitter side and the right hand part the receiver. The first antenna and transmitter part of the circuit are inside the vacuum chamber. Inductive power transmission in this circuit brings important benefits for the performance of the gun; beam power control can be implemented at close to ground potential, and the isolation between this system and the -60 kV potential is provided by the vacuum environment of the gun. [6-8]

The gas is fed through a fore line at a pressure of the order 1 bar and then this pressure is dropped down by a needle valve as the gas enters the plasma chamber, which is at a pressure of the order 1 mbar. This is necessary in order to keep the plasma only

inside the plasma chamber. Following the Paschen law [9], the plasma will most readily be initiated at the lowest voltage breakdown at a pressure in the range of mbars. Therefore, the plasma chamber is kept at this pressure, whereas the fore line and vacuum chamber are kept at high pressure (of the order of bars) and low pressure (10^{-5} mbar) respectively, so that the voltage breakdown value is much higher.

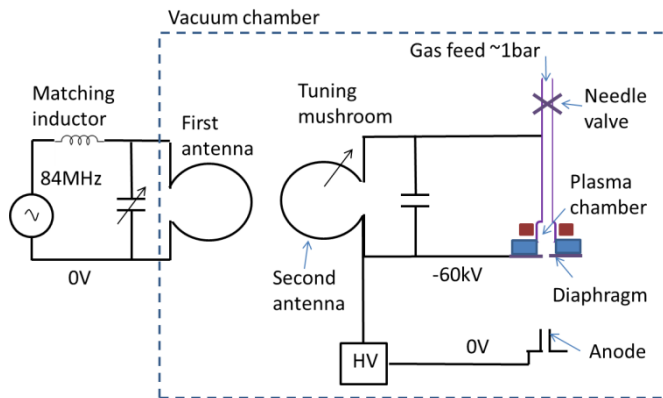

Fig.1. Electrical diagram of the plasma cathode electron gun. Reproduced by permission of TWI Ltd.

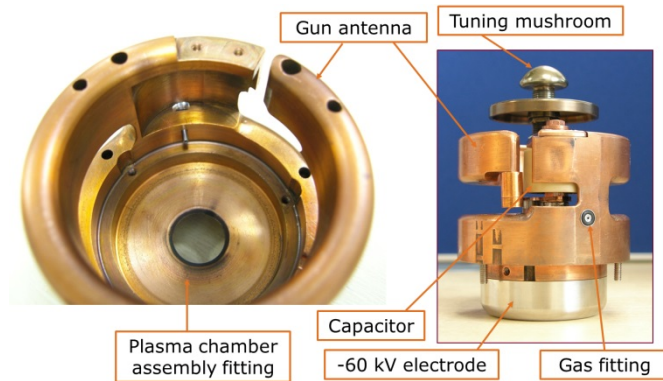

Fig.2. Plasma cathode gun body showing top view (left) and front view (right). Reproduced by permission of TWI Ltd.

An RF signal of up to 50 W was applied and the voltage generated from the induction in the second antenna is applied to the plasma chamber. A high voltage gradient is applied between the plasma chamber and the anode. Thus, the electrons are extracted through the diaphragm and accelerated towards the anode to form a beam. The vacuum chamber is constantly evacuated by a turbo pump and backing pump in order to maintain a pressure of 10^{-5} mbar.

Figure 2 shows a picture of the EB gun body. The left hand view shows the second antenna and plasma chamber assembly fitting. This part was made from copper. The right hand view shows the -60 kV electrode which was made from stainless steel.

Experimental Methodology

Figure 3 shows a diagram of an experimental set up used in preliminary tests.

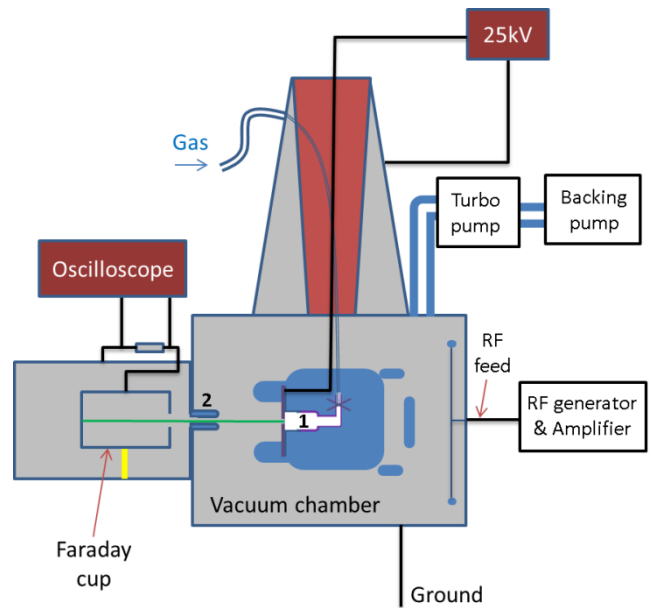

Fig.3. Diagram of the experimental set up for the test carried out at -25 kV accelerating voltage and 84 MHz excitation signal. The electrons are extracted from the plasma chamber (1) through the diaphragm and accelerated towards the anode (2) to form a beam. Reproduced by permission of TWI Ltd.

The RF signal coming from an RF generator and amplifier is fed to the first antenna. Resonant coupling is used to maximize the power transmitted to the second antenna. In order to bring the system to its resonance frequency, a tuning mushroom can be used to tune the inductance of the second antenna. A variable capacitor is also connected in parallel to the first antenna. Once the system is in resonance, a current is induced in the second antenna and the voltage picked up is applied to the plasma chamber. A high voltage gradient is applied and the electrons extracted from the plasma chamber form a beam. The beam was collected in a Faraday cup and the current was measured on an oscilloscope. [6-8]

The design parameters involved in the beam generation tests are presented in Table 1. Different plasma chamber geometries were tested. Air, argon and neon were used in the experiments.

The diaphragm aperture diameter had to satisfy the compromise of being wide enough to allow electron extraction and at the same time not to let too much gas into the vacuum chamber, which would lead to a high voltage breakdown.

Table 1

Values of the main parameters involved in the plasma cathode EB gun operation.

RF output power amplitude	Up to 50 W
Resonant frequency	84 MHz
Induced RF signal	1-10 kV
Diaphragm aperture diameter	0.1-1 mm
Plasma chamber diameter	<12 mm (1-3 mm)
Accelerating voltage	-25 kV to -60 kV
Plasma chamber pressure	0.1 mbar to 1 mbar
Gas feed pressure	1 bar

Preliminary Results and Discussion

A test at -25 kV accelerating voltage and 84 MHz plasma excitation frequency was carried out.

Figure 4 shows the LO-HI transition of the beam current. A current of -3 mA is on about 200 ns after the RF power is switched on. Figure 5 shows the HI-LO transition. The current is switched off in approximately 800 ns after the RF power is off. These switching times are over 100 times faster than times achieved with thermionic guns. [6]

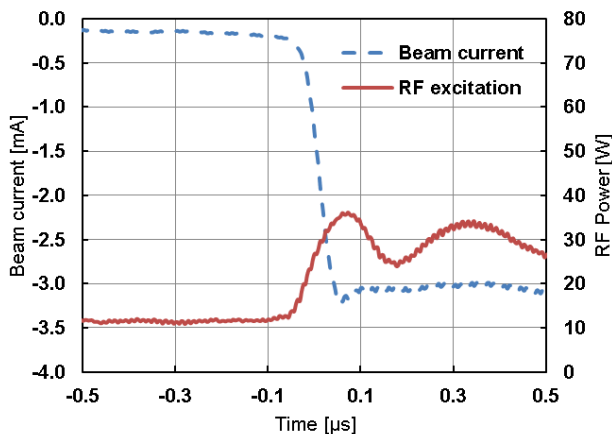

Fig.4. LO-HI transition of the electron beam controlled by modulation of the plasma excitation signal. Reproduced by permission of TWI Ltd.

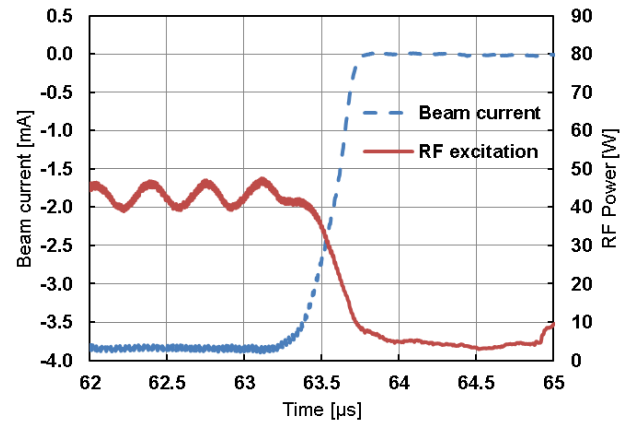

Fig.5. HI-LO transition of the electron beam controlled by modulation of the plasma excitation signal. Reproduced by permission of TWI Ltd.

Optical Emission Spectroscopy Measurements

Optical emission spectroscopy is a passive method that allows studying the plasma without affecting it. Radiation from atoms and molecules provide information on the plasma processes and plasma parameters, and observation is in real-time [5]. The light emitted from the plasma is recorded, generally using an optical spectrometer. The information included in a radiation line is shown in Figure 6.

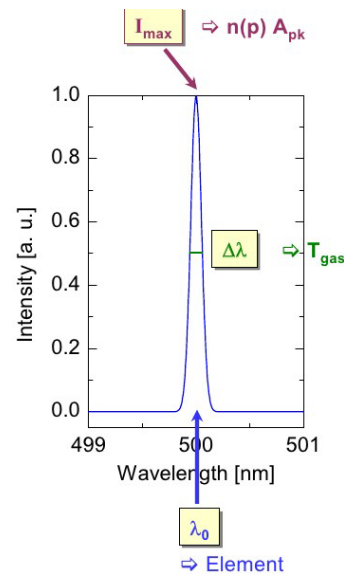

Fig.6. Information included in line emission, where λ_0 is the central wavelength of line emission, I_{max} is the relative intensity of the line, $\Delta\lambda$ is the line width at half-maximum, T_{gas} is the temperature of the gas, $n(p)$ is the particle density, and A_{pk} is the probability of the transition [5].

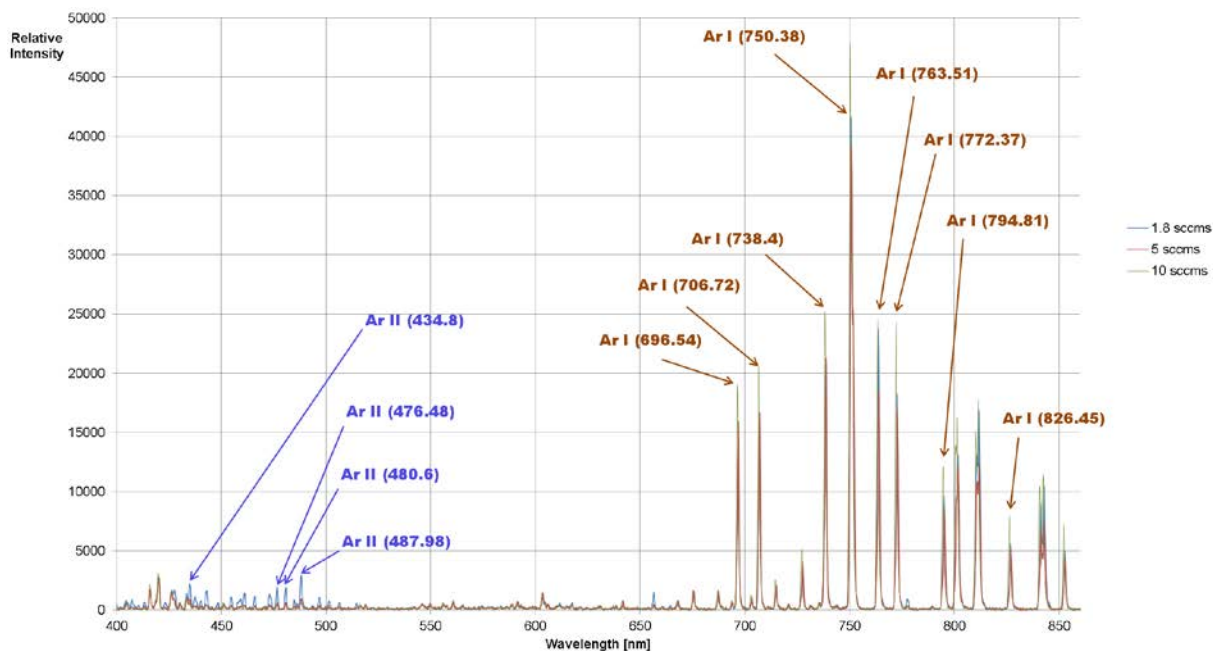

Fig.7. Emission spectra of an argon plasma at different gas flow rates. Reproduced by permission of TWI Ltd.

In order to increase the beam power, a separate experimental set up has been put together to carry out optical emission spectroscopy measurements. This will allow a greater understanding to be gained about the plasma parameters that contribute to achieving the maximum beam power, such as electron density, plasma pressure and plasma chamber geometry. The aim is to find the optimum parameters in order to extract the maximum electron beam power.

The experimental equipment for looking at the plasma generated comprised an Ocean Optics optical spectrometer USB4000 with enhanced sensitivity (~1.5 nm FWHM optical resolution) and an optical fibre with numerical aperture of 0.22 ± 0.02 (this yields an acceptance angle of 25.4° in air) [10]. These were used to record the emission radiation spectrum of the plasma from 200 nm to 850 nm wavelength. The fibre was positioned perpendicular to the quartz window and opposite the diaphragm aperture in the plasma chamber.

A mass flow controller was used to accurately measure the amount of gas that was fed into the plasma device. By keeping the gas flow constant, the stability of the plasma was highly improved. With this arrangement it was possible to maintain the generation of a stable plasma for many hours.

Figure 7 shows the emission spectra of argon plasma generated at three different gas flow rates. The strong lines were identified using data from NIST [11].

Conclusion and Future Work

A plasma cathode gun design has been presented and preliminary results demonstrate empirically that it provides solutions to the main problems encountered with thermionic guns. The plasma cathode allows repeatable performance during the processing of a material. Modulation of the RF signal can be used to control beam power. This is very beneficial in some material processing applications such as additive manufacturing, since it can be desirable to switch the beam on and off as it is moved to different points in a powder bed. The cathode is not damaged by ion bombardment and thus EB processing at coarse vacuum can be considered. [7]

The present beam power achievable limits applications to those at lower power such as additive manufacturing and surface modification. The setup used to carry out spectroscopic measurements of argon plasma has been described. The emission spectra of the argon plasma generated in the plasma gun device has been presented. Future work will use the optical emission spectroscopy system developed for this study to investigate the properties of other gases allowing a more detailed understanding of the effects of various parameters on the level of beam current produced.

REFERENCES

- [1] Schultz, H., *Electron Beam Welding*. Cambridge, UK: Abington Publishing, 1993.
- [2] Sanderson, A. *Electron beam welding generators*, U.S. Patent 4072356, 7 Feb. 1978.
- [3] Pierce, J. *Theory and design of electron beams*, 2nd ed. New York, 1954.
- [4] Rempe N. et al. *Welding and Cutting*, 11(2), 2012.
- [5] Fantz, U. *Basics of plasma spectroscopy*, *Plasma Sources Sci. Technol*, Vol. 15, Oct. 2006, pp. S137–S147.
- [6] Ribton, C.N. et al., *Plasma source apparatus and method for generating charged particle beams*, U.S. Patent GB1210607, Jan. 3, 2012.
- [7] Del Pozo, S., Ribton, C. N., Smith, D. R. *A novel RF excited plasma cathode electron beam gun design*, *IEEE Transactions on Electron Devices*, DOI 10.1109/TED.2014.2299339.
- [8] Del Pozo, S., Ribton, C. N., Smith, D. R. *Spectroscopic Measurement in a Novel RF Excited Plasma Cathode Electron Beam Gun Design*, accepted for presentation at IVEC'14, Monterey, CA, 2014.
- [9] Paschen, F. *Analytical Physics*, Vol.37, 1889, p. 69.
- [10] Ocean Optics Inc. *Optical Fiber Assemblies*, [Online]. Available: www.OceanOptics.com [2014, May 1].
- [11] Kramida, A., Ralchenko, Y., Reader, J., and NIST ASD Team (2013). *NIST Atomic Spectra Database* (ver. 5.1), [Online]. Available: <http://physics.nist.gov/asd> [2014, April 11]. National Institute of Standards and Technology, Gaithersburg, MD.

Eng. Sofia del Pozo - received the B. Eng. degree with honours in industrial engineering in electronics from Castilla-La Mancha University, Toledo, Spain, in 2011, and the M.Sc. degree in advanced engineering design from Brunel University, London, UK, in 2012.

She is currently pursuing the Ph.D. degree in electronic and computer engineering with Brunel University and she is based for her research at The Welding Institute (TWI) Ltd, Cambridge, UK. She has been working on the design, development and testing of a thermionic-cathode electron beam gun for the treatment of marine engine emissions as part of the DEECON project (FP7 programme). Her research interests include electron beam gun design, plasmas as electron sources, FE analysis, plasma diagnosis, and spectroscopy.

Ms. del Pozo is a student member of the Institute of Physics (AMInstP) and the Welding Institute (AWeldI), and

she was awarded the 'Alumni Prize for Advanced Engineering Design' for her Masters project by Brunel University in 2013.

e-mail: eepgsd1@brunel.ac.uk

Colin Ribton - graduated from the University of Nottingham with a joint honours degree in pure and applied physics and later joined TWI's Electron Beam group. He has also led development in a company developing novel antenna technologies, where he became Vice President of Application Engineering.

His roles at TWI have involved him in the computer modelling of electron optics and high voltage components, the design of high voltage power supplies, the design and optimization of radiation shielding, real-time control system architecture, and the design of digital and analogue electronics. In particular, this has been involved in the development of equipment and processes to manufacture major components in power generation, nuclear, aerospace and medical applications. He is presently a Technology Consultant in the EB group where he is active in promoting EB technology for new applications.

Colin Ribton is a Chartered Physicist (CPhys), a Chartered Engineer (CEng), a Member of the Institute of Physics (MInstP), and a Member of the Welding Institute (MWeldI).

Dr. David R. Smith - received the M.Phys. honours degree in physics with space science and systems from the University of Kent, Canterbury, Kent, U.K., in 2000, and the Ph.D. degree from the University of Leicester, Leicester, U. K., in 2004. His Ph.D. thesis was entitled "Radiation damage in charge-coupled devices."

He has continued to do research in the field of radiation dosimetry and radiation damage in silicon devices and is currently a Senior Lecturer in the School of Engineering and Design at Brunel University, Uxbridge, U.K. He has published a number of papers on the effects of proton damage on CCD operation, in particular the generation and characteristics of bright pixels exhibiting "random telegraph signal" behaviour, and the effects of radiation damage on the operational characteristics of electron-multiplication CCDs.

Dr. Smith is a Member of the Institute of Physics (MInstP), a Fellow of the British Interplanetary Society (FBIS) and a Fellow of the Higher Education Academy (FHEA).