

Purified by blood: honour killings amongst Turks in the Netherlands

Eck, Clementine van

Veröffentlichungsversion / Published Version

Dissertation / phd thesis

Zur Verfügung gestellt in Kooperation mit / provided in cooperation with:

OAPEN (Open Access Publishing in European Networks)

Empfohlene Zitierung / Suggested Citation:

Eck, C. v. (2002). *Purified by blood: honour killings amongst Turks in the Netherlands.*. Amsterdam: Amsterdam Univ. Press. <https://nbn-resolving.org/urn:nbn:de:0168-ssoar-317070>

Nutzungsbedingungen:

Dieser Text wird unter einer CC BY-NC-ND Lizenz (Namensnennung-Nicht-kommerziell-Keine Bearbeitung) zur Verfügung gestellt. Nähere Auskünfte zu den CC-Lizenzen finden Sie hier:

<https://creativecommons.org/licenses/by-nc-nd/4.0/deed.de>

Terms of use:

This document is made available under a CC BY-NC-ND Licence (Attribution-Non Commercial-NoDerivatives). For more information see:

<https://creativecommons.org/licenses/by-nc-nd/4.0>

Clementine van Eck



Purified by Blood

Honour Killings amongst Turks
in the Netherlands

AMSTERDAM UNIVERSITY PRESS

Purified by Blood

PURIFIED BY BLOOD

Honour Killings amongst Turks in the
Netherlands

Clementine van Eck

AMSTERDAM UNIVERSITY PRESS

For G.J. van Eck (1919-1975)

Cover design: Sabine Mannel/NAP, Amsterdam
Lay-out: JAPES, Amsterdam

ISBN 90 5356 491 8
NUR 747/761

© Amsterdam University Press, Amsterdam, 2003

All rights reserved. Without limiting the rights under copyright reserved above, no part of this book may be reproduced, stored in or introduced into a retrieval system, or transmitted, in any form or by any means (electronic, mechanical, photocopying, recording or otherwise) without the written permission of both the copyright owner and the author of the book.

Table of contents

Preface 7

Introduction 9

- 1. Honour and honour killing** 15
 - 1.1. Two types of honour: *namus* and *şeref* 15
 - 1.2. Honour killing and blood revenge 32
 - 1.3. Turkish jurisprudence and honour killing 34
 - 1.4. Islam and honour killing 37
 - 1.5. Honour killing in the Netherlands 39

- 2. The victim** 43
 - 2.1. Who is the victim? 43
 - 2.2. Rape claims 49
 - 2.3. Honour killing of newborn babies 51
 - 2.4. Honour killing of a member of the honour violator's family 52
 - 2.5. Multiple honour killings 55
 - 2.6. Honour killing of an implicated third party 56
 - 2.7. The wrong person is killed 59
 - 2.8. Failed honour killing 60
 - 2.9. The funeral 64
 - 2.10. Protests against honour killing 67

- 3. The honour killer** 73
 - 3.1. Honour killing as a ritual 73
 - 3.2. Planning: accomplices 78
 - 3.3. The honour killer has motives of his own 88
 - 3.4. Female honour killers 89
 - 3.5. Hired assassins 91
 - 3.6. Disguised honour killing 93
 - 3.7. Dutch jurisprudence and honour killing 95

- 4. Marriage and elopement** 99
 - 4.1. The rejected marriage proposal 100
 - 4.2. Elopement 104

4.3.	Honour killing following an elopement	118
4.4.	The girl is killed	122
5.	More case studies	129
5.1.	Authority over the children	129
5.2.	Incitement to murder	132
5.3.	A crime of passion	137
5.4.	Sexual insults	142
5.5.	Pathological honour killing	146
5.6.	Murder/manslaughter for reasons of male pride	151
6.	Alternatives to honour killing	157
6.1.	No more responsibility for the woman	158
6.2.	No action	164
6.3.	Minimum response	167
6.4.	Withdrawal	172
6.5.	Calling in the authorities	173
6.6.	Injuring the <i>namus</i> of the honour violator	182
7.	Why an honour killing?	183
7.1.	Pressure from the Turkish community	185
7.2.	Objectives other than honour purification	193
7.3.	Provocation	197
7.4.	Circumstances of the honour killer or accomplice	199
7.5.	Honour killing following an elopement	202
7.6.	Honour killing within the family	204
7.7.	Other contributing factors	209
7.8.	The situation of immigrants	211
	Conclusion	221
	Appendix I. More case studies from the court records	223
	Appendix II. Case studies from Bitlis province	237
	Appendix III. The Turkish Criminal Code (TCK) and honour killing	241
	Notes	245
	Literature	289
	Index	301

Preface

When I graduated from the Catholic University Nijmegen as a cultural anthropologist and embarked on Turkish Studies at Leiden University, my lecturers Dick Koopman and Ane Nauta drew my attention to the topic, 'honour killings among Turks in the Netherlands'. They assumed – quite correctly – that the subject would interest me as a cultural anthropologist. It is an area in which they had been working since the 1970s, following regular approaches from the courts and the police with requests for information. I would like to thank them for bringing the subject to my notice. I especially wish to thank Ane Nauta, with whom I had various discussions – during my Turkish studies – about honour killing cases on which he had been asked to give his opinion as an expert witness.

Unfortunately, it was not possible within the Turkish Department to devote a thesis to honour killings, but in 1995 I had an opportunity to research this topic at the Amsterdam School for Social Science Research, Amsterdam University. This is one of the few research schools in the Netherlands that allows you to write your doctoral thesis on a subject of your own choice. Anton Blok of Amsterdam University and Henk Driessen of the Catholic University Nijmegen were excellent supervisors. In addition, members of the doctoral students' anthropology group (the 'anthropology club') at the Amsterdam School for Social Science Research provided me with useful feedback. I also wish to thank Johan Goudsblom for helping to assess my interim papers. Matthijs van den Bos, Frank Bovenkerk, Lenie Brouwer, Martin van Bruinessen, Léon Buskens, Remco Ensel, Dick Koopman, Cees Maris, Ruud Peters, Wibo van Rossum, Hermine Wiersinga and Erik-Jan Zürcher all provided me with useful commentary. Aspha Bijnaar, Mieke Komen and Geertje van Os helped not just with matters of substance, but gave me moral support as well. I would like to thank the librarians at the University Library in Leiden, who were always happy to conduct literature searches for me.

I wish to extend my gratitude to a number of people in Turkey: the late Osman Badraslı, for providing me with the Bitlis case studies (see appendix II); his daughter Övgü, who trained as a librarian in

Ankara, for tracking down Turkish literature on honour and honour killings; and both Judge Muzaffer Cebesoy and Public Prosecutor Zekeriya Sevimli in Ankara, for explaining Turkish law relating to honour killings. Furthermore, I would like to thank Neslihan Sümer, a Turkish anthropologist at the University of Ankara, who wrote her doctoral thesis on female murderers in Turkey and with whom I was able to discuss various aspects of honour killings.

My thanks also go to Pitstra of the Central Judicial Archives in Almelo for a list of all instances of murder and manslaughter committed in the Netherlands by people born in Turkey. From this list, I was able to trace various cases of honour killings. Information relating to the police and the courts, I obtained from Frank Kornaat, Arno Bijl, and others who prefer not to be named. I am very grateful to New Zealander, Annette Visser, for her willingness to make such an excellent English translation of my Dutch text.

It is no easy task conducting research if you have two young children. I am therefore very grateful to my parents-in-law, who often came over from Ankara to help us. In addition, I would like to thank Judith for all her hard work. I owe my mother gratitude for her support. I am indebted to my husband, Bahadır, for his help and his patience. I dedicate this thesis to my father who, in his capacity as a social worker at a caravan camp in Emmen, can rightfully be called an anthropologist *avant la lettre*.

Introduction

This study looks at honour killings committed by Turks in the Netherlands.¹ Honour killings are murders that are carried out to purify tarnished honour, the honour in question being *namus*.² Both men and women possess *namus*. For women and girls, *namus* means chastity, while for men it means having chaste female family members. A man is therefore dependent for his *namus* on the conduct of the womenfolk in his family. This means in effect that women and girls must not have illicit contact with a member of the opposite sex and must avoid becoming the subject of gossip, since gossip alone can impugn *namus*. Girls must adhere to the *namus* code of behaviour, which differs from region to region. In general, it would be true to say that rules governing conduct are more stringent in the countryside than in cities, in Eastern than in Western Turkey and inland than on the coast. Throughout Turkey, however, with the exception of the modern urban élite in Istanbul, Ankara and Izmir, a young woman is expected to be a virgin on her wedding night and thereafter to remain sexually faithful to her husband.

Alongside geographical differences with regard to *namus*, there are changes over time. Attitudes towards *namus* were more rigid in the past than they are now (this is illustrated clearly in *Meyro*, a collection of stories by Necati Haksun). It is not my intention to examine the concept of *namus* and attitudes toward honour killings in earlier times, but we should be aware that ideas about *namus* have changed over time and will continue to do so.

Honour killing originated in the countryside but, as a result of migration since the 1960s and 1970s, we also encounter it in Turkish cities and in Western Europe (the Netherlands, Belgium, Germany, France, Denmark and Sweden). Insofar as we can ascertain, honour killings only occur amongst people of rural origin and their children. More highly educated urban Turks do not regard honour killing as a means by which to purify their *namus*.³ For this reason, I have not included this group in my study. Instead, I examine the culture of rural Turkey, which may live on among villagers who have moved to the city.

If honour is impugned, Turks speak of a ‘question of honour’ (*namus davası*⁴ or *namus meselesi*). The remedy is to purify one’s *namus*. This initially occurs without the shedding of blood; honour killing is a last resort. If asked why an honour killing was committed, Turks will usually respond: ‘It was a question of honour.’ Further explanation is deemed unnecessary. In this study, I intend to demonstrate that honour killings are not the inevitable consequence of an attack on honour and that this response does not contain the whole truth. Instead, an honour killing marks the starting point for my research. My initial research question was: ‘Why in this particular question of honour was an honour killing resorted to?’ I have retained this question in the title of chapter seven, where I explore the issue, but it is a very difficult question to answer. A better formulation would have been: ‘What factors increased the likelihood of an honour killing in this case?’ Honour killing clearly involves more than simply a loss of *namus*. In some cases, it is related to *şeref*, which also means honour, but honour in the sense of ‘reputation’, ‘prestige’.

The term honour killing is almost unknown in the Netherlands. Ane Nauta coined the Dutch word *eerwraak* (literally, honour revenge) in 1978 because no word as yet existed. It does not appear in the standard dictionary, the *Van Dale Groot Woordenboek der Nederlandse Taal* (thirteenth edition 1999), though it is listed as a headword in *Nederlandse Jurisprudentie* (NJ) [Dutch jurisprudence].⁵ The term ‘blood revenge’ is better known, which explains why we sometimes encounter it in newspapers and even court records when in fact honour killing is meant. However, blood revenge refers to a murder that occurs as a consequence of a previous murder, when a family avenges the death of one of its members by killing a member of the perpetrator’s family. Blood revenge can unleash a blood feud, a chain of killings in which murder after murder is committed by each side in turn.⁶ Honour killing, on the other hand, is the ‘first murder’.

Honour killing is a widely known phenomenon in Turkey. The *Hürriyet* newspaper reports an average of six such killings a month.⁷ However, no study has been made of honour killings in Turkey. The Turkish politicalologist, Doğu Ergil, has written an article entitled *Honor Crimes*, but this is largely a summary of what Pitt-Rivers and Peristiany had to say on the subject of honour in the Mediterranean, and in particular Southern Spain. Ergil did, however, devote part of his book, *Türkiye’de terör ve şiddet*, to his own research into honour killings.⁸ Interesting studies on the Turkish concept of honour in-

clude those by cultural anthropologists Carol Delaney, Michael Meeker, Andrea Petersen and Werner Schiffauer. None of them, however, touch on the subject of honour killings. Honour killings among Turks in the Netherlands are also a largely unexplored area.⁹ Such killings are in no sense restricted to Turkey or to Turks, however. They occur throughout the Mediterranean and even beyond, in Latin America. A review of the literature on honour in the Mediterranean can be found in Driessen 1997, but these studies make scant reference to honour killings. Exceptions are the Israeli researchers Joseph Ginat¹⁰ and Gideon Kressel¹¹, each of whom has written an article on honour killings among Bedouins and Palestinians in Israel and the occupied territories. In addition, Safilios-Rothschild has devoted an article to honour killings in Greece.¹²

For my research, I consulted thirty sets of court records of honour killings committed in the Netherlands in the period 1972 to 1993. These files can be found in the archives of various magistrate's courts and high courts. I was given permission to consult the files by the Ministry of Justice, with the proviso that, for reasons of privacy, I should not contact the defendants or any members of their family referred to in the files. Time constraints made it impossible to gain a complete picture of all honour killings.¹³ I have included twenty of the thirty cases in this study; the remainder I set aside because of the degree of overlap with other cases or because they contained too many uncertainties.¹⁴ I have also included one case reported to me verbally by the Dutch police (the Dağ case study). In order to spare the reader too many honour killings at once, I begin with one per chapter and gradually increase the number.¹⁵ I explain only what is relevant to the subject of the chapter. The disadvantage of this approach is that it leaves the reader with an incomplete overview of the case, but I felt it desirable to avoid repetition. I have also included honour killings in Turkey, taken from the European edition of the Turkish newspaper *Hürriyet*. Four cases of honour killings and alternatives from Bitlis Province in eastern Turkey, I obtained from a local informant (see appendix II), and one from a documentary.¹⁶ I chose to discuss such a large number of case studies because a single case would not shed light on all aspects of honour killing. The sum total presents a broader picture.

It is customary for cultural anthropologists to go out 'into the field' and live among the people who are the subject of the study in order to learn their customs and habits. However, this method is too time-consuming for a study of honour killings. Alternatively, instead

of consulting court records, I could have unearthed cases by word of mouth and interviewed those involved. But once again, it is impractical to collect case studies in this way. I also doubt whether I would have elicited the same information years after the event; the perpetrators and those close to them would tend to give their own reconstruction of events. Moreover, discussing *namus* and loss of *namus* is taboo, which would have seriously hampered fieldwork. Court records have some advantages that oral sources do not. For instance, the information from telephone taps could not have been gathered by an anthropologist 'in the field'. However, it would not be true to say that I spoke to no Turks at all. I discussed matters relating to *namus* and *şeref* with the Turks in my social circle.

I have tried wherever possible to avoid legal terminology.¹⁷ One exception is the word 'murder', which has a broader meaning in everyday use than in criminal law. For the sake of clarity, I use this word in its legal sense. 'Murder' is a deliberate premeditated killing (section 289 of the Dutch Criminal Code), whereas the term 'manslaughter' is reserved for a deliberate, unpremeditated killing (section 287 of the Dutch Criminal Code).

The names and places I refer to are fictitious.¹⁸ I have omitted the province of origin of the people involved, as this would identify them too easily. This device should not imply that people throughout Turkey share the same view of honour killings: these vary from region to region.¹⁹ Honour killing is more common in eastern than in western Turkey, although westward migration has made this distinction less clear-cut.

Despite my attempts to disguise true identities, insiders will recognise the honour killing cases I describe. Even if I omitted more details, I believe this could not be avoided. I have therefore retained references to specific years. When I use the general formulation 'between 1972 and 1993,' readers should not assume that this refers primarily to honour killings committed twenty odd years ago. Of the twenty case studies I describe, four date from the 1970s, eight from the 1980s and eight from the 1990s, although my study only runs until 1993.²⁰ Thus, the phenomenon of honour killing is certainly not confined to the early years of Turkish migration to this country.

When I refer to 'Turks' in this study, I mean the inhabitants of Turkey and migrants from Turkey. This does not imply that honour and honour killings are identical for all ethnic groups in Turkey. Further research is needed to look into possible differences between Kurds, Turks and Circassians. We also need to find out whether

there are regional differences. For example, are there attitudinal differences between people from the Black Sea region, Central Anatolia and southeastern Turkey? I hope to address these questions in a follow-up study.

Almost without exception, the court records contain a wide range of randomly ordered documents: official police records; the report from the inquest, the official charge, the evidence, the penalty for the crime, the justification for the sentence and verdict and reports from the probation officer and sometimes from a psychiatrist, psychologist or expert witness. The records also contain photos of the victim and of the scene of the crime. In one case (the Dursun case study), there is a transcript of telephone conversations obtained by means of telephone taps. Other items include letters written in Turkish by the defendant and newspaper articles about the case. On occasions, I was able to supply missing details by talking to police officers involved in the case (the Altuğ, Dursun, Köksal, Şengül, and Tekin case studies). In none of the cases was the crime set out chronologically in the records, which means I could not ‘copy’ the case studies directly from the files. Instead, I had to reconstruct them on the basis of the countless documents contained in the file; the wording is my own.

When examining court records, it is important to bear in mind that those who committed the honour killings were questioned by the police, and at a later date, by the courts. They would have wanted to present their case in the most favourable light. In particular, the defence counsel will have pushed for manslaughter rather than murder. The researcher must constantly be alert to the fact that the ‘informant’ in the records is the defendant. Although this is in some ways a disadvantage, we can at least be clear about the position the informant adopts. A pitfall for researchers ‘in the field’ is the too-ready assumption that informants are providing correct and impartial information.

In the police reports, suspects appear to be quoted verbatim. However, in their written report of the interrogation, the police combine their own questions with the suspect’s responses to form a single sentence (eg. “Now that you ask how I came by this pistol, I have to tell you...”). So although these appear to be the suspect’s exact words, they are not. The fact that these statements are indirect reports becomes clear when we realise that suspects were often assisted by interpreters. The police report, however, only contains the Dutch translation. Therefore, when I present the statements of sus-

pects, these are not verbatim but rather a representation of what was said as it appears in the police files.

The court records are assembled with a view to providing sufficient evidence to pass sentence on the defendant, and not to provide answers to each and every question a cultural anthropologist might come up with. This means that, from an anthropological point of view, insufficient attention may have been given to family background and to the defendant's circumstances.²¹ Moreover, some information may be omitted from the records because it is not considered relevant for sentencing purposes. In my conversation with a police officer, I discovered that the police suspected the involvement of an accomplice in the Şengül case, information which I was unable to glean from the records. However, because honour killings constitute special cases in Dutch jurisprudence, the court records are generally well documented and they provide a relatively large amount of information.

I. Honour and honour killing

I.I. Two types of honour: *namus* and *şeref*

THE DURSUN CASE STUDY: 'THE CASSETTE TAPES' (1991)¹

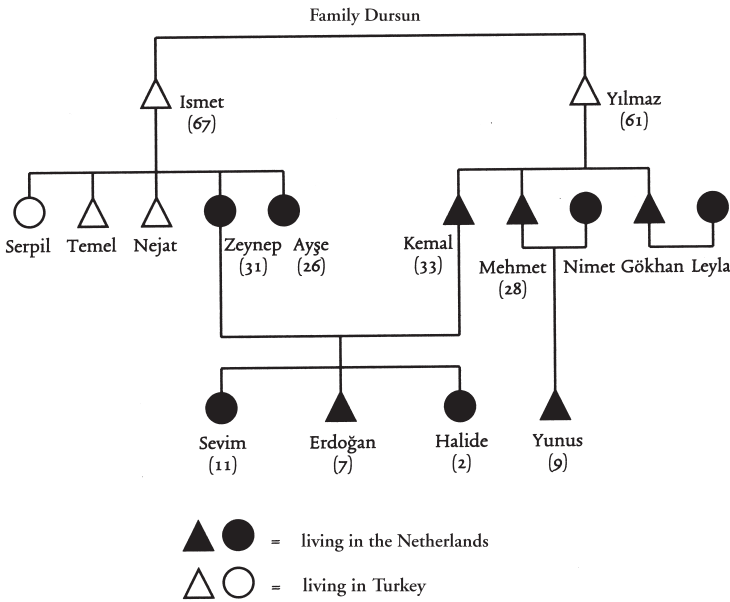

Fig. 1: The Dursun case study

Zeynep Dursun lives with her parents, brothers and sisters in a village in Turkey. At fifteen, she is married off to Kemal Dursun, the seventeen-year-old son of her father's brother, who lives with his parents in the Netherlands. The couple go to live in the Netherlands, where Zeynep finds work as a packer in a factory. After they have been married for five years, their first child is born, a daughter whom they call Sevim. Four years later a son, Erdoğan, is born. When the children are three and seven years old,

Kemal is declared unfit for work and receives a worker incapacity benefit. Some time later, the couple decide to divorce under Dutch law. Zeynep stops work and receives a social security benefit. Under Turkish law, however, she is still married. Neither set of parents is informed about the divorce and the couple continues to live together (although, officially, Kemal has moved in with one of his brothers). One year later a daughter, Halide, is born, whom Kemal claims as his own. The divorce was probably a sham so that the couple could claim a double benefit. All the same, the marriage is not a good one: Kemal scarcely spends any time at home with his wife and children. From 1985 onwards, he has a Dutch girlfriend with whom he spends every weekend. He spends weekday evenings and, after his disablement, entire days in a coffee house.

Another Turkish family, the Eralps, live near the Dursuns. The couple are about twenty years older than Zeynep and Kemal Dursun, and have four children. In 1984, the Eralps' eldest son is killed in an accident. Zeynep visits the family frequently to try and comfort them. She forms a close friendship with Mrs. Eralp, who begins to regard her as her own daughter. Five years later, Ali Eralp is declared unfit for work. He now spends a great deal of time at home and begins a relationship with Zeynep, which the other members of the family do not know about. However, Ali Eralp starts spending a lot of money on Zeynep and Mrs. Eralp panics when all their savings begin to disappear. She suspects him of adultery but she doesn't know who the woman is.

In January 1990, Mrs. Eralp finds out about the relationship between Zeynep and her husband when she discovers a cassette tape with sounds of the two of them making love. She wants Ali to break off the relationship but he has no intention of doing so. Mrs. Eralp tells her family in Turkey what is going on. When they visit their native village that summer, the families of Mr. and Mrs. Eralp mediate to patch up the marriage. Nevertheless, things go wrong again shortly after the holiday because Ali continues seeing Zeynep.

In May 1990, an anonymous letter addressed to Kemal is delivered to the coffee house belonging to Mehmet Dursun (Kemal's brother, who is five years younger than Kemal). The letter claims that Zeynep is having relationships with several men. Four months later, Ayşe Dursun, Zeynep's sister, comes to the Netherlands. She tells the police that she will live with her cousin Mehmet (who is separated from his wife). In fact, she goes to live with Zeynep. Ayşe's arrival means that Zeynep can no longer receive her lover in secret at home and they start meeting in his car.

At the end of 1990, the council allocates Kemal his own house and he decides to take it. Zeynep wants him to go and live there so she denies him ac-

cess to what she calls *her* house. But Kemal feels that she is still his wife and he wants to be able to come to the house whenever he feels like it. They argue, and Kemal assaults Zeynep. She reports him to the police in January and again in February 1991. In February, she goes to live in a women's refuge. When she returns home, she has the locks changed so that Kemal can no longer enter the house.

Zeynep presses Ali Eralp about a permanent relationship but he is not interested. In January, he goes to Turkey for a time but Zeynep manages to persuade him over the phone to return to the Netherlands. Meanwhile, Mrs. Eralp and her two daughters, Yasemin (17) and Feride (16), have developed such an aversion to Zeynep that they actually come to blows. In this period, two tyres on Zeynep's car are punctured (the police do not know who did it but they suspect the female members of the Eralp family). For Ali Eralp, tensions mount to such an extent that he decides to go to Turkey again in March 1991, returning in April. Zeynep wants to arrange a meeting but Ali Eralp thinks the situation has become too dangerous and does not dare to.

On 2 May 1991, Zeynep is subjected to so much harassment from Mrs. Eralp and her daughters that she decides to go to the police station to lodge a complaint. As soon as she has left, Ali Eralp phones her home. Ayşe picks up the phone and they exchange a few words. Ayşe wonders how a strange man can call Zeynep as she has an unlisted number. Her conclusion is that Zeynep herself must have given the man the number.

When Zeynep comes home, Ayşe demands an explanation. Zeynep admits that she is having a relationship with Ali. Ayşe is furious and leaves that same day to move in with Nimet, officially the ex-wife of Mehmet (though here too there was probably no actual divorce). She immediately tells her the whole story and also phones her brother Temel in Turkey. Kemal, who is also told, turns white with anger. Even he doesn't know Zeynep's unlisted number, and yet this other man does! Together with his brothers, Mehmet and Gökhan, he tries to find out as much as he can. They discover the existence of the cassette tapes (Mrs. Eralp has made copies) and they visit Mrs Eralp to ask for them. She is very frightened of the men and hands over the tapes.

The brothers decide that Zeynep Dursun must die and they discuss who should carry out the murder. They decide to hire someone and a certain Turgay Korkmaz agrees to do the job. The plan is that Osman, a young man who works in Mehmet's coffee house, will drive Korkmaz to the appointed place. Gökhan and Kemal will go to Paris the evening before the murder. Mehmet will stay in the Netherlands to make sure that all goes according to plan. Mehmet arranges to meet Zeynep at the house of his ex-wife Nimet (probably his own house in fact). He questions her about her relationship

with Ali. Zeynep admits in veiled words that it is true. Once Zeynep has gone, Mehmet leaves the house in a rage. He tells Nimet that he could kill the woman. Nimet is frightened and immediately calls Zeynep's neighbour, a Turkish woman, to tell her that Zeynep's life is in danger and that she should leave the minute she gets home.

When Mehmet goes outside, he realises that something has gone wrong. Korkmaz was supposed to kill Zeynep at Nimet's house but he has missed her. Mehmet leaps into his car and overtakes Osman and Korkmaz. Witnesses are later able to testify that they saw the two cars riding alongside one another with windows down. Mehmet and Korkmaz were probably deciding on their strategy.

When Zeynep drives up to her house, her children are outside. Her eldest daughter, Sevim, who is eleven, comes running up to tell her that the neighbour said she must leave immediately. Zeynep quickly asks for her bag. At that moment, Mehmet comes tearing into the street in his car. He stops next to Zeynep's car, pulls the gun out of his waistband and cocks it. He grabs two-year-old Halide, who is playing in the street. Zeynep then gets out of her car. Mehmet lets go of the child, grabs Zeynep by the hair and puts the gun to her head. Zeynep falls to her knees and begs Mehmet not to kill her, but Mehmet says that he intends to. Korkmaz then comes running up. Mehmet takes the gun away from Zeynep's head but still holds her by the hair. Korkmaz aims his pistol at Zeynep and shoots her in the face. As Mehmet drives off in his car, Korkmaz shoots again, this time in her stomach. She is shot dead in front of her three children.

After the murder, the 28-year-old Mehmet goes home and picks up his wife (or ex-wife) Nimet, his son Yunus and his cousin Ayşe. At the petrol station, he is so confused that he tanks up with diesel instead of petrol. There he spots two military police officers, to whom his description has just been phoned through, and he decides to give himself up on the spot. He says he was present at the murder but that he didn't do it. All adults in the car are taken to the police station for questioning. Korkmaz is driven directly to Schiphol by Osman and leaves the Netherlands without being caught. He is picked up two years later at an airport in Germany because of an international warrant out for his arrest. The court sentences him to 20 years imprisonment as an accessory to murder. He appeals and the sentence is reduced to 18 years. Mehmet Dursun is sentenced to 14 years imprisonment as an accessory to murder. His sentence is reduced to 12 years following an appeal.

The above case involves an honour killing to purify the honour of the family. The Turkish term for this kind of honour is *namus*, and it re-

lates to the purity of women and girls. A man is also said to possess *namus* if the female members of his family are 'honourable' (*namuslu*). If *namus* is violated, we speak of a question of honour (*namus meselesi*). Although this particular case ended in an honour killing, we should not see this as the inevitable outcome when a question of honour arises.

We can point to a number of factors that brought matters to this conclusion. If a girl or woman is the subject of gossip, people look first to the person responsible for her *namus*. In the case of an unmarried girl, that person is first and foremost her father, followed by other male members of the family (her father's father, her father's brothers, her brothers). In the case of a married woman, responsibility initially lies with her husband and then with the male members of his family (father, brothers, sons). As far as we know, the latter is not true of Arabic Islamic regions, where the young woman's father and brothers retain primary responsibility for her even after her marriage.² This does not imply, however, that a married Turkish woman can no longer injure the *namus* of her blood relatives. A loss of *namus* on her part entails a corresponding loss for them. They are not chiefly responsible for the loss, however. If a husband permits his wife to commit adultery and is not taken to task by his father and brothers, the woman's blood relatives may feel obliged to intervene.³ But an honour killing by a blood relative does not necessarily indicate that the husband is opposed to the killing: he may have reasons for not killing her himself and for leaving it to his brother-in-law.⁴

In addition to *namus*, Turks have another word for honour, namely *şeref*.⁵ This term, meaning 'status', 'prestige', 'standing', requires further explanation.⁶ To what does a man attribute his *şeref*? From time immemorial, it has derived from qualities such as courage, reliability, honesty (*dürüstlük*), and his ability to protect his possessions (his land, wife and children). Being married and having a wife and children (preferably one or more sons) add to his *şeref*. *Şeref* also derives from the 'respect' (*saygı*) shown him by his wife, children and inferiors. A man's origin and degree of economic success contribute further to his *şeref*. Economic success does not simply mean having a high income and a respected profession, but also being independent (being his own boss rather than earning a wage) and owning land (the more the better). *Şeref* is not having to work but having others work for you. Military service can grant a man *şeref*. So too can piety: being knowledgeable about the life of the Prophet, being able to quote from the Koran by heart and making the pilgrimage

to Mecca (the *hac*). These last two activities confer the respective honorary titles of *hafız* and *hacı*.⁷

The above discussion should not imply that all Turks make such a clear-cut distinction between *namus* and *şeref*. The two concepts are in fact tightly interwoven. A graphic representation of *namus* and *şeref* would not involve two separate circles, but rather a large circle (*şeref*), containing within it a smaller one (*namus*).⁸ For some, the *namus* circle would be small; for others, it would almost coincide with the *şeref* circle.⁹ This latter group consists of men whose only means of deriving status is by having a respectable wife and daughters.¹⁰ If we closely examine how these terms are used among Turks, we see that *şeref* and *namus* are often interchangeable. This is understandable given that, for many men, their *şeref* derives almost solely from their *namus*.

In keeping with the anthropological literature, I have in this study reserved the term *şeref* for men.¹¹ Yeşilgöz (1995: 84) also applies the term exclusively to men. However, I have spoken to several Turkish women¹² who are adamant that they too have *şeref*. They maintain that women derive this quality from the following: being married,¹³ having children, having one or more sons, being good housewives, bringing the children up well, being honest, taking good care of their husbands, and not committing adultery. Thus *şeref* assumes a different form for women than it does for men. A woman possesses *şeref* by performing her womanly duties well, and a man through the proper fulfilment of his manly duties (with the exact form varying according to the individual and the age group). The qualities that make up a woman's *şeref* reveal that, like men, women regard *namus* as a component of *şeref*.¹⁴

This distinction in Turkish between the two types of male honour is not found throughout the Mediterranean.¹⁵ In Spanish and Italian, there is a single word for a man's honour, *honor* and *onore*, respectively. For a woman's honour, chastity, another word is used: *vergüenza* or *vergogna*, which means shame. This same distinction is made in the literature: *honour* for men and *shame* for women. In references to male honour, it is not clear whether honour in general (*şeref*) is meant, or honour that relates specifically to having chaste female family members (*namus*). Some researchers therefore make an ethic distinction for the purpose of clarification. Pitt-Rivers, who conducted research in Spain, breaks honour down as follows: honour = precedence, by which he means status/origin; honour = virtue, to denote honour in the sense of reliability; and honour = shame, mean-

ing having chaste female relatives. In Turkish, the first two are *şeref* and the last *namus*. Safilios-Rothschild (1969: 215), who conducted her research in Greece where they have the single term *philótimo* to denote male honour, also speculates that there might be two kinds of *philótimo*: one for having chaste female family members and one referring to the ‘male ego’. In this way she too distinguishes between *namus* and *şeref*.

Arabic makes a similar distinction to Turkish, with the terms *sharaf* and *’ird* or *’ard*.¹⁶ *Sharaf* is comparable to the Turkish *şeref*, while *’ird* or *’ard* means to have honourable female relatives.¹⁷ This Arabic word also exists in Turkish, namely as *ırz*. It means the same as *namus* but is only used in fixed expressions, such as *ırzına geçmek*, ‘to rape’, ‘to sexually assault’ (literally, ‘to transgress *ırz*’) and *ırz düşmanı*, ‘violator of honour’ (literally, ‘the enemy of *ırz*’).¹⁸

There are yet more words in Turkish for ‘honour’. *Iffet* and *sililik* are synonyms for *namus*. The first comes from Arabic and is mainly used in religious contexts. *Sililik* is one of many neologisms coined after the founding of the Turkish Republic in 1923 in an attempt to purge borrowed Arabic and Persian words from the language. Many of these neologisms have since become part of standard Turkish but others, including *sililik*, are only found in dictionaries. Alongside *şeref*, we find *izzet*, *haysiyet* and *onur*. The first is a rarely used borrowed word from Arabic, whereas the second and third (borrowed Arabic and Italian words, respectively) are in common use. But the most common word denoting *şeref* is *gurur*, which means ‘pride’.¹⁹ If *şeref* is at stake, people generally speak of *gurur meselesi*, ‘a matter of pride’, and not of *şeref meselesi*.

In the literature, *namus* is usually translated as ‘sexual honour’ or ‘family honour’ and *şeref* as ‘personal honour’. However, *şeref* is not exclusively personal. If someone possesses *şeref*, all members of the family share in it. I translate the term *şeref* as ‘prestige’ or ‘status’, but I have also left it untranslated. For *namus*, in addition to using the Turkish word, I use ‘family honour’, or simply ‘honour’ when it is clear that *namus* is meant.

On the one hand, *şeref* renders a man’s *namus* vulnerable because a wife and children always entail responsibility. On the other hand, a man needs *şeref* to keep his *namus* intact because he must be able to protect his wife and daughters from men outside the family. This demands specific behaviour vis-à-vis other men. A man is expected to become easily annoyed if other men display an interest in the female

members of his family and to react with acute sensitivity to insults or harassment directed toward his wife or daughters.²¹

But vigilance with regard to other men is not enough. The danger may come from within. A man must ensure that his wife and daughters do not injure the family honour. In other words, he is not expected to tolerate all aspects of their conduct. The word 'expected' should not imply that a man only acts in order to satisfy the expectations of the community. Many Turkish men become distraught if, without advance notice, their wives come home a little later than expected, angry if another man enters the house when their wife is home alone, and completely beside themselves if they even suspect that their wife is seeing another man. Standard comments in these situations are: *Benim namusum söz konusu! Kime gittin?* (My *namus* is at stake here. Who did you go and see?) and *Namusuma kimseye laf söyletmem* (I won't let anyone comment on my *namus*). But such behaviour is expected from a husband. If he shows no concern about his wife's activities and whereabouts, he is not a real man in the eyes of other Turks. A Turkish man should be *kıskanç* (jealous). This is viewed as a positive trait by others, including his wife, as it means that he cares about her. This explains why some Turkish women are proud of the fact that their husbands forbid them certain things.²² While working in a Turkish women's centre, trying to interest poorly educated Turkish women in the courses on offer, I was told very excitedly by some of them: "My husband won't allow me to go out in the evenings", and "My husband won't let me go to school".²³

Thus to keep his *namus* intact, a man must be able to protect and control the female members of his family. He can only do this with the help of his *şeref*. By behaving 'in a manly way' (*şerefli*), he demonstrates that he attaches great importance to his *namus*, thereby preventing an attack upon it from inside or outside the family. The greater a man's *şeref*, the less fearful he need be about loss of *namus*. According to Schiffauer (1986: 3): "Jeder muss über *şeref* verfügen, um die Ehre (*namus*) seiner Familie schützen zu können." For a man, *Şeref* serves as a shield. By making clear to the outside world that he has *şeref*, a man can be assured that no one dare do anything to his wife or daughter.²⁴ In Bourdieu's view, *namus* makes a man vulnerable, but he can enlist the support of his *şeref* to respond to an attack on his *namus*: "Honour [*namus*], that which makes the group a target for outrage, is opposed to the point of honour [*şeref*], that by which it can respond to outrage." Bourdieu sees the possession of *şeref* as an important precondition for maintaining *namus*: "Only the

punctilious, active vigilance of the point of honour [*nif*= *şeref*] is capable of guaranteeing the integrity of honour [*hurma* = *namus*] – which, being the sacred, is, by nature, exposed to sacrilegious outrage – and of winning the esteem and respectability that society confers upon the man who has enough point of honour to keep his honour safe from offence.” Or, as Bourdieu states even more cogently elsewhere: “The sacred (*hurma*) [...] exists only by virtue of the point of honour (*nif*) that defends it.” According to Bourdieu and Schiffauer, a family with considerable *şeref* can rest assured that nothing will injure its *namus*: “A great family [...] known for its *nif*[*şeref*], its sensitivity and determination, [...] is shielded from offences, since, by virtue of the threat that it always holds out for potential aggressors, it is seen as capable of riposting in the very instant that it is offended. The respect a good family inspires is reflected in the expression ‘they can sleep and leave the door open.’”²⁵

An important aspect of *şeref* is the respect (*saygı*)²⁶ that a wife and children show their husband or father. The *saygı* of wife and daughters is chiefly to uphold *namus*, but it extends to other spheres as well. If, in the presence of others, a woman shouts at her husband or openly expresses a different opinion, his *şeref* is injured. It is not just the female members of a family who accord a father *saygı*, but the sons as well. A man whose sons show him deference is seen as strong, while a man whose sons show him no respect is viewed as weak (*zayıf*). In order to count within the group of men to which he belongs, a man must command respect within his family.²⁷ Sons should not hold different views from their father, but should obey him unconditionally. If the outside world observes that this is not the case, the father loses *şeref*.²⁸ *Saygı* thus provides further protection for *namus*, both directly (through the wife and daughters) and indirectly (through the sons). Just as *şeref* is important for *namus*, the reverse is also true. If a man’s loss of *namus* becomes public knowledge, his *şeref* is affected accordingly.

Namus and *şeref* share two key similarities: they are group values and public opinion is vital to both. If a woman behaves honourably (*namuslu*), her whole family possesses *namus*. If a single woman in the family is without *namus*, the whole family is held responsible, and they share in her loss of *namus*.²⁹ Thus, we can understand why Zeynep’s adultery affected not only her husband Kemal, but his brothers Mehmet and Gökhan as well. It also explains the lack of solidarity between the sisters. Sisters will not always help one another to circumvent the rules; on the contrary, they may be the first to betray

one another. If one sister forfeits her *namus*, that of her sister is immediately called into question.³⁰ We see this clearly in the Dursun case study. As soon as Ayşe discovered that her sister Zeynep had a boyfriend, she informed Zeynep's husband and her brother Temel in Turkey. She did nothing to help Zeynep conceal the relationship. The court records contain little information about Ayşe. All we know is that she was twenty-six years old and unmarried, which is unusual for a woman from a Turkish village. For whatever reason, it seems no marriage could be arranged for her in Turkey. I believe that the Dursun brothers were making use of Ayşe. They invited her to come to the Netherlands and took care of her residence permit. Although supposedly living with Mehmet, she in fact lived with Zeynep, who could hardly refuse her own sister. Under the pretext of offering Ayşe new prospects abroad, the Dursun brothers probably hoped that Zeynep would end her extra-marital affair once her sister came to live with her.

Key components of a woman's *namus* are virginity before marriage and sexual fidelity to her husband. But *namus* is a broader concept that incorporates public opinion as well. The community is the judge in matters of *namus*. At issue is not whether a woman is pure, but whether she is seen as such. It is the interpretation of the facts rather than the facts themselves that is important.³¹ For this reason, women and girls steer clear of anything that, in the view of others, might bring them into improper contact with a man from outside the family. To avoid being talked about, they adhere to community norms governing *namus*. Virginity and sexual fidelity are no safeguard against becoming the subject of gossip if a woman or girl fails to conduct herself as she should. People are quick to label her a 'whore' (*orospu*). The word has a broad meaning: whores are women who do not adhere to the rules governing chastity,³² women who commit adultery, or girls who have a boyfriend.

Violated *namus* gives rise to a 'question of honour' (*namus meselesi*) or an 'honour feud' (*namus davası*). This applies even if no one outside the family knows about it: it is sufficient that a male member of the family knows what has happened. We should emphasise here that it is not only public opinion that counts. A man may himself conclude that his *namus* is lost and feel obliged to take action. Pitt-Rivers defines honour as follows: "Honour is the value of a person in his own eyes, but also in the eyes of his society", and "The notion of honour is [...] a sentiment, a manifestation of this sentiment in conduct, and the evaluation of this conduct by others, that is

to say, reputation. It is both internal to the individual and external to him.”³³ If only the woman knows that her honour has been compromised, a question of honour does not arise. She may choose not to tell anyone in order to prevent it from becoming an issue. If, on the other hand, outsiders also know (but not the male members of the woman’s family), a question of honour does arise. In such a case, no one will have dared inform the woman’s family.

Şeref is also a group value. If a man has considerable *şeref*, this is reflected on other members of his family. Here too public opinion plays a key role. Wealth is only relevant to *şeref* if it is displayed (a new car, gold jewellery, a nice apartment). Important here is the notion of *gösteriş* (displaying, parading). Many Turks cannot understand Dutch people who respond to a compliment on their clothes with: “Oh, it’s just something cheap I picked up at the market.” The art is to make something cheap appear as expensive as possible.

Unlike *şeref*, *namus* is an absolute, without gradations. You either have it or you do not. In principle, everyone has *namus* from birth.³⁴ *Şeref*, on the other hand, is a quality one possesses to a greater or lesser extent and which may increase throughout a lifetime.³⁵ This is not the case with *namus*, which everyone has, and to the same degree: they must simply ensure that they do not lose it.³⁶ These characteristics of *namus* and *şeref* are reflected in language usage. With regard to *namus*, Turks speak of ‘losing’ or ‘tarnishing’ honour (*namusunu kaybetmek* or *namusunu kirletmek*), and by analogy ‘redeeming’ and ‘purifying’ honour (*namusunu kurtarmak* and *namusunu temizlemek*). For *şeref*, however, the expression is ‘acquiring’ or ‘earning’ honour (*şeref kazanmak*), which cannot be said of *namus*. All that matters with regard to *namus* is that it remain pure and untainted. Once tarnished, it must be purified. One cannot speak of ‘purifying’ *şeref*: that applies only to *namus*.

A further distinction between *namus* and *şeref* is that, although both are critical family values, *namus* is the more sacred.³⁷ This is reflected in the expressions ‘a Turk lives for his *namus*’ (*bir Türk namusu için yaşar*) and ‘you live for your *namus*, you die for your *namus*’ (*namus için yaşanır, namus için ölünür*).

So great is the importance attached to *namus* that complete panic can ensue if it is attacked. This is what happened to Mehmet Dursun in the case study described earlier. As soon as he had in his possession the tapes that proved adultery, he went in great confusion to his boss. Still wearing his Walkman, he pointed to the cassette tape inside it and asked for the day off. The boss later told the police:

“Mehmet told me there’d been rumours for months about his sister-in-law’s adultery. I know Mehmet as a westernised Turk and I was surprised to see him so upset about it. When I told him he couldn’t take the day off, he left in tears. He was really very upset. I’d never seen him like that. In the end, I let him have the day off.” Proof of his sister-in-law’s adultery clearly had a devastating effect on Mehmet. But he obviously regretted his openness because, later that day, he called his boss to tell him that all the problems concerning the adultery had been resolved. He probably realised that if his boss made a statement to the police, he would quickly be suspected of being an accessory to the murder.

It is difficult to say why *namus* has acquired such significance.³⁸ It is customary to point to the importance that men attach to their ‘own children’. A woman must be protected and controlled so that a man can be sure he is raising his own offspring.³⁹ However, this does not adequately explain the continuing importance of *namus* today.⁴⁰ A more productive approach would be to examine the contexts in which *namus* figures.⁴¹ This brings us to groups that have the following eight characteristics:

1. The families in the group have a close network of relationships; in other words, the friends of the family are also acquainted with one another.⁴² Here, gossip emerges as the primary mechanism of social control: everyone’s behaviour insofar as it affects *namus* is subject to comment.⁴³
2. The members of the group depend on one another for social and other contacts. This renders them vulnerable to group opinion and therefore with regard to their *namus*.⁴⁴
3. Relationships are ‘many-stranded’: people are not just neighbours but friends and colleagues as well.⁴⁵ Many-stranded relationships mean that people do not belong to separate categories. The different networks overlap one another, so much so that they are sometimes identical. Moreover, people are often related as well, with the result that there is no separate category of ‘family members’.⁴⁶ A consequence of these interwoven family ties is a lack of privacy and a subsequent high level of social control.⁴⁷
4. There are no alternatives. Because there are no opportunities to withdraw from group control, honour is particularly vulnerable.⁴⁸
5. The group is homogeneous, thereby increasing the likelihood that everyone shares the same view of the *namus* code, which in turn makes the code more stringent.⁴⁹

6. There is a prevailing group culture of hospitality. Studies suggest that, where there is a good deal of coming and going, there is little opportunity for concealment and the *namus* code exerts a greater influence on the individual. De Vries writes that Hindustanis from Suriname would prefer not to have unannounced visitors because they wish to avoid gossip. Gilmore says the same of a Spanish agricultural town, and Bott of a working-class neighbourhood in London. Elias and Scotson found that the custom of 'just dropping by', especially among women, meant that the families in the research neighbourhood did not have the same degree of privacy as middle-class families.⁵⁰
7. In the event of loss of *namus*, the group has sanction options such as public ridicule and ostracism. Individuals who know of or suspect the possibility of sanctions will be more attentive to their *namus*.⁵¹
8. Individual and collective identity are closely linked: if someone does something wrong, the entire family and even the whole group is shamed. As a rule, groups that satisfy all these criteria are small in scale. However, this alone does not adequately account for the importance of *namus*. It is unlikely to acquire such significance if members of a small group simply live in the same neighbourhood but have little to do with one another.

It is easy to understand how the situation described above applies to Turkish villages. People know one another, and contacts are confined to present and former villagers (this applies more to women than to men). Networks overlap and, in particular, thanks to inter-marriage within the village, there is almost no distinction between the categories of 'family' and 'local resident'. If a person's *namus* is irreparably damaged, withdrawing from the situation is difficult, as this would mean severing all contacts. For farmers, moving is not really an option. In general, the inhabitants of a Turkish village form a homogeneous group. The prevailing culture is one of hospitality, with frequent visits back and forth, especially among the women. Villagers also have recourse to sanctions in the form of critical gossip, ridicule and allusions to honour killing.

We might easily assume that *namus* is less important in cities than in villages. However, until research is carried out in this area, we cannot be certain.⁵² In the first place, cities are less anonymous and individualistic than we might think.⁵³ Bott, who conducted research in London, observes that the group form, and subsequent so-

cial control, is sometimes maintained in the city. An urban neighbourhood can operate as a kind of village, with all the attendant consequences (here, the importance attached to *namus*).⁵⁴ Secondly, living in a city does not necessarily involve adopting an urban culture. Many city dwellers originally come from rural areas, bringing their village culture with them. Because they live together in the same part of the city, social control continues as before. Often, it is even stronger because the former villagers are surrounded by outsiders – city dwellers – whom they suspect of having a more flexible attitude toward *namus*. Thirdly, urban Turks, who do not live in a group where everyone monitors the comings and goings of others, also set great store by *namus*. One clear example of a difference between ‘modern Turks’ and their Western European counterparts is that the first group would not refer to former boyfriends of their wife in the presence of another man. For Western European and American men, this is simply not an issue. When my Turkish husband, Bahadır, and I met our Dutch neighbours and they heard the name of our child, the husband made the spontaneous comment to his wife: “Hey, that was your ex-boyfriend’s name too.” He went on to explain that his wife used to have a Turkish boyfriend. I discovered later that Bahadır was amazed at this conversation. What kind of man tells other people that his wife had a boyfriend before they were married? A similar incident occurred at the bank where Bahadır works. The then director, an American, was at a meeting with Turkish businessmen where they were talking about being successful in society. The director cited as an example his wife’s former boyfriend, a Japanese man, who was very successful in the United States. This made the Turks very uncomfortable. Bahadır later told me: “He needn’t have mentioned the fact that it was an ex-boyfriend of his wife’s. That wasn’t at all relevant to the example!” However, the example demonstrates that it was of no concern in the least to the American that his wife used to have a boyfriend.

There are of course implications for societies where *namus* plays such a vital role. Ideally, the woman’s world and the man’s world are separated, and Turkish society is organised accordingly. One example concerns the conventions on inter-city buses. A man and a woman who are not related are never seated next to one another. The extent to which this rule is applied became apparent to me when I travelled by bus from Istanbul to Ankara. A Turkish boy was sitting in front of me, and a Turkish girl in front of him. During the journey, the boy began talking to the girl, much to the displeasure of the

driver's assistant (*muavin*), who came by with increasing frequency, frowning. After a stop, when everyone got off the bus to eat, the boy went to sit next to the girl, which galvanised both the assistant and the driver into action. Without asking the girl what she wanted, they made the boy go back to his seat behind her. Such behaviour was simply out of the question; they wanted no disgraceful conduct on their bus. We find further examples of segregation in Turkish society at beaches and on café terraces in the cities where signs indicate the areas reserved for women and families (*aileye mahsus*).⁵⁵ Where spatial segregation is not possible, temporal segregation is introduced. For example, men and women attend the bathhouse (*hamam*) at different times.

Families from a rural background will marry their daughter off at an early age since a girl of marriageable age represents a danger to her father and brothers. By marrying her off quickly, they transfer responsibility to her husband. When choosing a bride and daughter-in-law (*gelin*), the boy's parents look at the girl's family rather than the girl herself. To be certain of bringing a virtuous girl into the family, they prefer to choose someone from their own family or, failing that, from the same village. They can then be confident that she has conducted herself honourably and will not bring shame on the family. A girl who marries outside her own village is therefore viewed with suspicion: her *namus* may be questionable.⁵⁶ The preferred marriage is to the daughter of one of the father's brothers (*amca kızı*), as this girl already belongs to the patrilineal family.⁵⁷ Other favoured marriages are to the daughters of the father's sister (*hala kızı*), the mother's brother (*dayı kızı*) and the mother's sister (*teyze kızı*).⁵⁸ Delaney writes that all marriages in her research village were endogamous, in other words, inside the village.⁵⁹ Of these, 25 percent of the villagers married full cousins, 50 percent married other relatives, and the remaining 25 percent married someone else from the village that was not related.⁶⁰

Kinship marriages are not customary throughout Turkey. In villages near Karasu in Adapazarı Province, marriage to a full cousin is considered a 'sin' (*günah*). Magnarella (1974: 87) writes that kinship marriages are uncommon among the Manav⁶¹ in Susurluk in Balıkesir Province in Western Turkey.⁶² According to Makbule Ölçen, Chairwoman of the Turkish Foundation for Mentally Handicapped Children, ten percent of the population of Turkey is mentally handicapped. She cites kinship marriage as the primary cause. She claims that if such marriages were banned, the number of mentally

handicapped people in Turkey would drop to one percent.⁶³ Both the Turkish and Dutch governments are conducting a campaign to convince Turks of the adverse effect that kinship marriages have on future generations.⁶⁴ Sirman, who carried out research in Tuz in Aydın Province, ascribes the small number of kinship marriages among the Muhacır⁶⁵ to the Turkish government's television campaigns, although, in a footnote, he subsequently puts these figures into perspective: the population group in question already had a tradition of exogamy.⁶⁶ The village mayor (*muhtar*) of Yaycıabdal köyü in Amasya Province informed me of repeated warnings on television about the medical risks of marrying a first cousin. He said that no handicapped children had been born in his village, despite the large number of such marriages. This was confirmed by the midwife (*ebe*), who came from another town and who was officially attached to the village health centre (*sağlık ocağı*). The medical risk in kinship marriages did have an effect on a Turkish couple living in the Netherlands, however. When all three of their daughters wanted to marry first cousins, the parents said they would only give their consent if the prospective son-in-law had a different blood group from the daughter. They believed this would prevent handicapped children from coming into the world, although there is no medical evidence to support this. But regardless of whether marriages occur within the same neighbourhood or between relatives, there is no way of knowing how the marriage will turn out when the partners have had little or nothing to do with one another beforehand. There is a common expression in Turkey: 'marriage is like a watermelon' (*Evlilik karpuz gibi*). You don't know whether you have a good one until you have bought it and cut it open.

Virginity before marriage is vital, hence the custom of tying a red ribbon around the bride's waist to show that she is a virgin. In many areas, it is still customary on the wedding night to inspect the sheets for bloodstains, a sign that the bride entered the marriage a virgin. With the exception of elite urban circles, it is not customary for a young woman to sleep with a man before marriage. Nor would a young man readily sleep with a virgin because of the risk that he would be forced to marry her. This obsession with virginity has even induced young women to undergo operations to surgically reconstruct their hymens.⁶⁷

The importance of *namus* is reflected in upbringing. From a young age, girls are taught to behave *namuslu* (honourably, chastely). Boys, on the other hand, learn that they are responsible for the *namus*

of female members of their family. This is already ‘second nature’ at a young age, as revealed by a story my mother-in-law tells. When her son was just three years old, he became angry with some men working in the garden of their house in Ankara. Because they had glanced inside, he shouted at them: “You’re not allowed to look at my mother! Watch out, or my father will hit you!”

The importance of *namus* is also reflected in the extreme sanction imposed on its loss, namely honour killing. Research into honour killings teaches us not only about the phenomenon itself but also about honour in general. We can study *namus* by looking at its opposite: dishonouring. This was the approach adopted by Goffman. In order to learn about the rules of a particular group, he studied people who did not adhere to them. Pitt-Rivers wrote: “Moral values are best examined through the sanctions that operate against their violation and honour is most clearly defined at the moment when it is lost.”⁶⁸ Burke indicates that although case histories are often used to exemplify something that occurs frequently, the reverse can also be true: “[...] a case may be selected for study precisely because it is exceptional and shows social mechanisms failing to work. It was in discussing this situation that the Italian historian Carlo Poni coined the phrase, ‘the exceptional normal’ [...]. Open conflicts may reveal social tensions that are present all the time but only visible on occasion.”⁶⁹ As a rule, *namus* is not discussed; it only becomes an issue when violated. Thus, the exception sheds light on everyday practice. Focusing on scandal and disgrace is a strategy for investigating the honour code.

In the *Hürriyet* newspaper, we find references to *namus cinayeti* (*namus* murder). Traditionally, however, the term *cinayet* (murder) is not used, but instead *namus temizlenmesi* (*namus* purification). Another age-old term is ‘*namus davası*’ (*namus* revenge), by analogy with ‘*kan davası*’ (blood revenge). Honour killing is also called ‘traditional murder’ (*töre cinayeti*), a much broader term that incorporates blood revenge. The customary expression with which the murderer justifies his deed is *namusumu temizledim* (I have purified my honour), which is an abbreviation of *namusumu kanla temizledim* (I have purified my honour with blood).⁷⁰

Honour killing probably arose because the state could not effectively control violence.⁷¹ With the government unable to protect its citizens, people had to defend their own possessions. As a result, everyone had their own gun or other weapon. Defending one’s land (*tarla*) was just as important as defending one’s women. ‘Land is

namus' (*tarla namustur*) is a common expression in rural Turkey, where there is a lack of effective state authority. There are mountainous areas, for instance, which the police cannot reach quickly. Nevertheless, private weapons and honour killings continue to be important in areas that do have effective state control. Because of urban migration, honour killing occurs in cities too. Insofar as we know, city dwellers with higher education rarely commit honour killings. The most likely explanation is their tendency to move in several circles at once, which means they are not completely dependent on a single group for their self-esteem. As a rule, urban Turks do know what honour killing is and they have some degree of sympathy for it. Because they too attach importance to *namus*, they understand why someone would commit such a killing.

1.2. Honour killing and blood revenge

A blood feud or blood revenge (*kan davası*) involves a killing in accordance with the principle of 'an eye for an eye, a tooth for a tooth'. If a blood relative is killed, a blood relative from the murderer's family must be killed. As a rule, an important male member of the family is selected as the victim, preferably a breadwinner, in order to maximise the impact on the other family. Following the murder, a further killing may take place, this time by the family of the second victim, thus unleashing a chain of killings. The period between killings may be very long – sometimes as much as twenty years – if, for instance, the son must wait until he has grown up before seeking revenge. Motives for the first killing in a series cover a wide range and include disputes about land or even honour killings. If an honour killing is followed by one or more acts of blood revenge, the initial killing that sparked off the feud is also called blood revenge.⁷² As with honour killings, as a result of urban migration, blood revenge is no longer the exclusive prerogative of villages. The migration of Turks to the Netherlands has brought blood revenge to this country too, with nine instances in the period 1975-1982.⁷³

In almost all cases, the perpetrators of honour killings and members of their family fear reprisals from the victim's family. In the Dursun case study, it emerged that Ismet Dursun, the father of the murdered Zeynep, planned to shoot his brother Yılmaz Dursun, the father of the brothers Gökhan, Kemal and Mehmet, because he suspected Yılmaz Dursun of having ordered the killing. Temel, Zey-

nep's brother, was also said to harbour such plans and to have sworn on his children to take revenge. Yılmaz Dursun had learned of this and passed it on to Kemal by telephone (the police intercepted these calls with telephone taps). Zeynep's blood relations wanted Ayşe, Zeynep's sister who was living in the Netherlands, to return to Turkey as soon as possible. As long as she stayed in the Netherlands, they could not retaliate for fear that the brothers would then do something to Ayşe. This was all the more reason for the brothers to prevent Ayşe from returning to Turkey. Nor did the Dursun brothers go on holiday to Turkey that year, for fear of reprisals. The phone-tap transcripts reveal that the father, Yılmaz Dursun, told his sons, who were in the Netherlands, that he had heard that Zeynep's family would pretend to be reconciled but in reality they planned to have Yılmaz shot by Nejat, Zeynep's youngest brother who was still single. It seems that everyone was afraid. We learn from the telephone tap that Leyla, Gökhan Dursun's wife, complained to a friend that she just sat at home, not daring to go out.

The Dursun brothers wanted to invite Zeynep's parents to the Netherlands to explain the whole situation to them and to prove that Zeynep really was bad. Yılmaz Dursun was initially opposed to the idea but the brothers eventually had their way. Serpil, Zeynep's sister, told Kemal over the telephone that everyone in the village looked askance at her parents because they were going to visit their daughter's murderers. Serpil wanted the Dursun brothers to arrange for her brother Temel to go to the Netherlands, which they promised to do. Kemal also promised to have Zeynep's brother Nejat brought over. Arranging for both of Zeynep's brothers to come to the Netherlands may have been an effective *quid pro quo*, a kind of blood money (*diyet*) to prevent blood revenge. Serpil believed that her brother Temel and her parents would calm down once they heard this. In fact, the brothers did succeed in convincing their aunt and uncle. The one thing Zeynep's parents continued to ponder was how Zeynep could have gone so completely 'off the rails' (Kemal would not have told his parents-in-law that he was rarely at home). Zeynep's parents may have been talked round because two of their sons were given an opportunity to come to the Netherlands.

1.3. Turkish jurisprudence and honour killing

The Turkish Criminal Code (*Türk Ceza Kanunu*, abbreviated as TCK) provides both directly and indirectly for reduced sentences in the case of honour killings. This judicial mitigation does not apply to blood feud. The penalty for blood feud has become much harsher in Turkey in an attempt to root out the problem.⁷⁴ Following the founding of the Turkish Republic in 1923, the Islamic courts were abolished in 1924 and civil law was adopted from Switzerland. The model for the Criminal Code, however, came from Italian law which tied in better with the Turkish concept of honour.⁷⁵ For example, section 587 provided for a reduced sentence if a man killed his wife because she had committed adultery.

The Turkish Criminal Code provides for a severe prison sentence of 24 to 30 years for murder with intent (section 448 TCK). If the victim is a member of the family, the penalty is a life sentence (section 449/1 TCK). Killing for the sake of purifying honour (*namus*) is not an aggravating circumstance; on the contrary, the Turkish Criminal Code contains two sections that provide for a reduced sentence where a killing is motivated by reasons of honour.⁷⁶

Section 453 deals with killing a newborn baby for reasons of *namus*. These are usually illegitimate births, whereby the baby has to be killed to prevent the mother – usually an unmarried girl – and her family from being talked about. Önder points out that, for this section of the law to be applied, the murder must have taken place directly after the birth of the child.⁷⁷

Section 453 was amended in 1991. It now applies only if the mother is the murderer and her motive was to safeguard her *şeref*, not her *namus*. The Turkish Public Prosecutor, Zekeriya Sevimli, whom I spoke to in Ankara in the summer of 2000, could not explain to me why *şeref* had replaced *namus*. His comment was: “They just want to appear Western.” Nor can Şahin explain the reason for this change. He believes the entire section, together with section 472, should be abolished.⁷⁸ Section 472 of the Turkish Criminal Code provides for a reduced sentence if a miscarriage is induced to protect *şeref* and *namus*.

Section 462 deals with the killing of a wife, sister, daughter or their lover after catching them in the act of adultery. Among themselves, Turkish lawyers call this ‘divorce Italian-style’ (*İtalyan usulü boşanma*) because this section was adopted from the Italian Criminal Code.⁷⁹ The prison sentence is reduced to an eighth of the customary

sentence provided that the crime is committed during or shortly after an unmistakable act of adultery or indecency.⁸⁰ It should be noted that a woman who kills her husband after catching him in the act of adultery can also appeal to this section. Thus the word *namus* does not appear in section 462, in contrast to section 453, which deals with infanticide. Here, in the old version, there was explicit reference to ‘saving *namus*’ (*namusunu kurtarmak*). If a woman kills her husband because he has committed adultery, the everyday term for this is not honour killing, but ‘murder out of jealousy’ (*kıskançlık cinayeti*). Public opinion is much less sympathetic than when a man kills his wife for the same reason.

If an honour killing is not covered by these sections of the law, a judge may elect to invoke the general sections 51 and 59. The judge may declare section 51 applicable in the event of acute sorrow (*elem*) or provocation (*tahrik*). If someone does not dare show their face in public because of loss of *namus*, the judge accepts this as ‘acute sorrow’. If a woman runs off with her boyfriend, this may be interpreted as an act of provocation toward the male members of her family. Under section 59, the sentence can be reduced at the discretion of the court if there are arguments in the murderer’s favour, such as good behaviour in court. Sections 51 and 59 are not specially reserved for perpetrators of honour killings.⁸¹

Zekeriya Sevimli, the Turkish Public Prosecutor in Ankara, informed me that, under the Implementation of Sentences Act,⁸² prisoners automatically serve only about forty percent of their sentence.⁸³ All those convicted benefit from these provisions, not just honour killers, for whom there are no special provisions.

Honour killing as camouflage

The section of the law dealing with reduced sentences for honour killings when a spouse is caught in the act of adultery was abolished in Italy because it was subject to abuse.⁸⁴ In order to qualify for a reduced sentence, defendants who had committed murder or manslaughter would claim in court that it had been an honour killing, although their motive had been quite different.⁸⁵ This is called ‘honour killing as camouflage’. I did not find this variant in the court records I examined, which is not to say that it was not present. Perhaps this possibility did not occur to the police at the time of their investigations. Only in the Dursun case study did ‘honour killing as camou-

flage' arise. The Dursun brothers tried to convince the probation officer that this was the case. When confronted with the transcripts of the telephone taps, they swore to the probation officer that they had used the term 'honour killing' because Zeynep's blood relatives were furious and were threatening to kill their father who lived in Turkey. Kemal Dursun said: "To save my father and to placate Zeynep's family, we put ourselves in their shoes and tried to present it as a question of honour so that they'd understand the murder. But it was definitely not an honour killing. When Gökhan and I were in Paris, Zeynep's murder came as a terrible shock to us too." In their version of the story, Zeynep was murdered by an unknown man and Mehmet Dursun had been at the scene to help Zeynep. The reason he grabbed Zeynep by the hair was to drag her away from the murderer.

We sometimes find instances of 'honour killings as camouflage' in the *Hürriyet*. Women in particular may be called upon to claim responsibility for the killing, to make the murder look like an honour cleansing.

In a courtroom in Sakarya, after months in custody, Sema Akın heard that the prosecution was demanding a twenty-year prison sentence for murder. She then blurted out that she had not murdered her 33-year-old brother-in-law. Her husband had killed his brother and had said to his wife: "You claim responsibility for the murder and say that you murdered him because of your namus. If you say that, you'll get a lighter sentence."⁸⁶

Sometimes the victim's family claims that the honour killing was a 'camouflage' because they are furious that the perpetrator might be let off lightly by claiming it was an honour killing. It is often difficult to deduce from the newspaper articles whether it is really a question of 'honour killing as camouflage':

The prosecution demanded fifteen years' imprisonment for Ayhan Bağlar. He claimed to have murdered his 33-year-old wife Seda because she was having a relationship with another man. However, Seda's mother, who was called upon as a witness, suggested that her son-in-law had murdered Seda because Seda had received a large inheritance from her father, which he wanted to keep for himself.⁷⁸

The murder of Uğur Kılıç in the Uludağ skiing region in January 1995 was initially presented as an honour killing. Alaattin ÇAKIRCI, a

leading figure in the Turkish mafia, told journalists that he had had his ex-wife killed because she was having a relationship with someone else. Nobody believed his explanation. Instead, they saw the murder as a settling of accounts within the Turkish mafia. Uğur was the daughter of Dündar Kılıç, another prominent mafia boss.⁸⁸

1.4. Islam and honour killing

Honour killing occurs throughout the Mediterranean, among both Christian and Islamic populations, and is not linked exclusively to Islam. It is a widely-held belief that honour killings are sanctioned by the Koran. But if we look at the actual penalty for adultery committed by a woman, we see that it is less severe than popular belief would have it. *Zina* (adultery, fornication or indecency) is an offence that must be punished with a *hadd* (a specific, invariable punishment). The Koran says: “The fornicatress and the fornicator – scourge each one of them a hundred stripes, and in the matter of God’s religion let no tenderness for them seize you if you believe in God and the Last Day; and let a party of the believers witness their chastisement.” (Arberry, 1983: 352).⁸⁹

Islamic scholars later set out Mohammed’s precise intentions. In the case of married people or those who have been married, the penalty for *zina* is being stoned to death. The penalty of flogging is confined to people who have never been married. The Koran contains no references to death by stoning. Instead, this penalty is based on traditions that are ascribed to the Prophet (*hadith*).⁹⁰

By law and in accordance with the words of the Koran, in cases where the guilty party does not voluntarily admit to the offence, *zina* can only be proven if four male witnesses who satisfy all legal requirements confirm the truth of the accusations (Koran 24: 4). However, the *hadd* punishment is a ‘law of God’ (*haqq Allah*), not a ‘law of man’ (*haqq Adami*). In criminal cases involving a *haqq Allah*, it is recommended that punishment be averted. The judge must alert the defendant to all circumstances that could lead to acquittal under the law. For example, the judge must expressly ask whether the *zina* might not be a ‘miscarriage of justice’ (*sjoebha*).⁹¹ In other words, that the defendant was unaware that *zina* was involved. In such cases, the law also requires that witnesses be advised to give no evidence that might prejudice the defendant. What this in effect means is that the *hadd* can only be applied in a case involving *zina* if the de-

fendant confesses.⁹² Even when a woman is pregnant, *zina* can be denied. She could say, for instance, that she became pregnant by going to the bathhouse where there were traces of sperm.

Given the many preconditions and circumventions outlined above, executions for reasons of *zina* can almost never be carried out. Nor does Islamic law in any way condone the manner in which honour killing occurs among Turks. Only an Islamic court may decide, after due legal process, to execute someone who has committed *zina*. Islamic law always forbids honour killing following a family council.⁹³

In Turkey, death by stoning following an instance of *zina* was still carried out sporadically in the 1960s by families acting on their own initiative. The writer Necati Haksun recounts this in his 1973 novel, *Kutsal ceza* (Holy punishment). Haksun, who was born in Tarsus in 1930 and who died there in 1992, worked for many years as a judge in Çatak, in Van Province in Eastern Turkey. He later published novels and short stories about various cases. In *Kutsal ceza*, he describes how a girl is stoned to death by her brothers.⁹⁴ As Haksun is related by marriage to my husband, I had an opportunity to speak to him in person in the summer of 1989, and can therefore state unequivocally that his novel describes reality, not fiction.⁹⁵ This type of honour killing also occurred in the Balkans in the 1920s. According to Durham, there was a common expression in the region: 'She ought to be under the cursed stone heap.'⁹⁶

There was also an incident in southeastern Turkey in which a dishonourable woman was subjected to a derived form of stoning. A newspaper article reports of a woman who was first killed and then stoned. The stoning thus had a symbolic function, to demonstrate that the woman was dishonourable and that her killing was an honour killing.

CASE STUDY: 'STONING IN THE SQUARE' (HÜRRİYET, 1996)

A newborn baby was discovered last week in a wheat field. Police investigations revealed that the abandoned baby was the illegitimate child of the 16-year-old Oruç Serin. The police released the girl and sent her to her uncle. The girl's 17-year-old brother came to collect her yesterday evening. When they reached the village, he took her to the square, where he pulled out his rifle and shot her in front of the other villagers. The girl's body was then stoned.⁹⁷

Although the *sharia* (Islamic law) neither prescribes nor condones honour killing as carried out among Turks, pious Turkish Muslims do invoke their faith when committing an honour killing.⁹⁸ Honour killing is said to be *sevap*, or meritorious according to Islam, a deed for which the perpetrator will be rewarded by God. Several of the killers in my study invoked their religion to justify their deed. While on remand for killing his wife (he believed she had been unfaithful), Akkaya had a Koran in his possession, which he kept carefully wrapped in a cloth as custom demanded. He referred to sura 102 in connection with his deed, although that sura does not relate to adultery. Biber, a minor who killed his mother, also invoked Islam. He said: “According to our religion – it is also written in the Koran – one of us [he or his father] has to do it”. Uzun said that he had carried out the killing ‘because his faith demanded it’. The 19-year-old Altuğ, who killed the man who had violated his sister’s honour, wrote in a letter to the court: “By raping my sister, this man insulted our *namus*, our *şeref* and even our religion [*namusumuz, şerefimizi, haysiyetimizi ve hatta dinimize hakaret etti*].” The fact that he mentioned *namus*, *şeref* and religion in the same breath shows how closely linked religion and honour were for him.

Some honour killers are aware that Islam does not condone honour killing. According to the psychologist’s report in the Utlı case study: “Utlı broods over the Koran. He asks himself how Turkish Muslims can claim that the Koran requires you to kill your wife if she has an affair. It doesn’t say that anywhere in the Koran.” And in the Türkmen case, the psychiatrist wrote: “If we were to test the crime of which Türkmen is suspected against the tenets of Islam, then he would expect – if a hereafter exists – to be punished by God. He believes, however, that the prevailing standards and values in his native village do permit such a deed. We will pursue this no further. Such an analysis seems to us to be a job for an anthropologist.” Türkmen is fully aware that Islamic law does not condone honour killing, but that local customs do.

1.5. Honour killing in the Netherlands

Are the Turks who immigrated to the Netherlands less bound by codes of honour, or more so? Giovannini sees this as an important area for research: “One essential research question is the differential survival of these cultural codes (female chastity codes) in contexts of

[...] migration.”⁹⁹ The circumstances that give rise to a heightened sensitivity toward *namus* have continued to flourish in the Netherlands, which explains why *namus* continues to be so important to Turks in this country. The Turks who came to the Netherlands did so partly through a pattern of chain migration,¹⁰⁰ whereby Turks already living here recruited new workers from back home at the request of their employers. They chose people from their own region, preferably their own village, which has resulted in different clusters of immigrants, each from a different part of Turkey.¹⁰¹ Turks from different regions who end up in the same city maintain their regional links. Thus we find, for example, that each group has its own coffeehouse.¹⁰² The relationships within these clusters¹⁰³ of Turkish guest workers are ‘many-stranded’: the men see each other regularly, not just in coffeehouses, but at work as well, in addition to being each other’s neighbours and relatives. The women also have regular contact with one another: they work together (in the bulb fields, at cleaning jobs) and make frequent – often unannounced – calls on one another.¹⁰⁴

First-generation immigrants are dependent on one another for social and other contacts, partly due to the language and cultural barrier. There is no way around this as even a change of job would lead to the same kind of work, with Turkish workmates once again. Moreover, the group is surrounded by Dutch people, whom they see as a threat to their culture, which only serves to strengthen the *namus* code. Because the first generation feels threatened, gossip about the morality of Turkish girls can be vicious.¹⁰⁵ Deug also shows that the group form has its disadvantages: “The greatest difference [between Dutch and Turkish girls] seems to be the fear that the community will come to learn (...) that a girl has lost her virginity (...). There is no need for a girl to explain to social workers from the same ethnic background that the community is breathing over her shoulder”.¹⁰⁶

This group type – in which everyone keeps a watch on everyone else – certainly applies to the Dursun family. They came from a village of six hundred inhabitants in the Black Sea region. Thanks to intermarriage, a significant number of the villagers have the same surname. About 100 people from the village came to the Netherlands, where they went to live in two adjoining towns (Turks from other regions also live there but there are no strong links between the different groups). The result is a large measure of social control and a heightened sensitivity to the *namus* code.

And what of the second generation who have since had children themselves? For the most part, the first generation has married off its children to someone from their native village. Many continue to live in the same neighbourhood, either because they lack the money to move or because they prefer to live in close proximity.¹⁰⁷ This explains the persistence of the group form, in which 'everyone knows everyone else'. Under these circumstances, there has scarcely been a reduction in the degree of social control.

2. The victim

2.1. Who is the victim?

It is not only women¹ who are victims of honour killings, but men too.² The one responsible for the loss of *namus* is killed. If a girl is raped, the rapist is killed, not the girl. If a woman turns to prostitution, then she is the guilty party and hence the victim, not the men who visit her. If both parties are guilty, as in the case of adultery, both deserve to die: first the man, and then the woman. The man is killed by the family of the woman or girl whose honour he has violated, the woman by members of her own family.³ In Arabic countries, according to Kressel and Ruggi, an innocent woman, such as a rape victim, may also be killed.⁴ We encounter this extreme sanction in the 1968 novel, *Reşo Ağa*, by Turkish writer Bekir Yıldız. The daughter of landowner Reşo is abducted against her will by a camel driver. Even though she retains her virginity, she is killed at her father's command. The novel is set in Urfa, where many people of Arabic descent live alongside the Kurds. It seems likely that the Arabic tradition described by Kressel and Ruggi still persisted there.

The Turkish language distinguishes between passive and active loss of *namus*. A woman who is the unwilling victim of *namus* loss is 'defiled or tarnished' (*namusu kirlenmiş*)⁵, whereas a woman who has contributed to the loss of her *namus* is not only defiled but also 'dishonourable' (*namussuz*). The latter term is worse as the woman is perceived as bad. In principle, only the woman labelled *namussuz* is killed, not the woman who is *namusu kirlenmiş*. In the latter case, the man is killed, as the 'honour violator' (*ırz düşmanı*).⁶

In situations where an honour killing is deemed necessary, however, the woman or girl is often shielded by her family, who turn a blind eye to the question of guilt. The family frequently goes to great lengths to point to the man as the guilty party. Claiming that the woman was raped, they kill the man, although he is in fact her lover. The family is not deluding itself here. Honour entails upholding one's reputation to the outside world. Provided others accept the 'rape' story, the family is content to kill the male transgressor.

For a man, there is no such distinction. Once he has lost his *namus*, it is 'tarnished' (*kirlenmiş*). A man is not 'honourable' (*namuslu*) or 'dishonourable' (*namussuz*), depending on whether the female members of his family are chaste. When applied to a man, these terms refer to his own conduct. A man who is *namuslu* is well brought up and will not impugn the honour of women, unlike a man who is *namussuz*. If the women concerned are willing, he is a Don Juan or a womaniser (*çapkın* or *zampara*). However, a man who is *namussuz* does as a rule possess *namus* (*namusu var*); after all, his own wife is sitting safely at home. Such a man only loses his *namus* (*namusu yok*) if he incites his wife to dishonourable behaviour, such as forcing her into prostitution. The anthropological literature on Turks has either failed to report, or has reported incorrectly, the different usages of *namussuz* and *namuslu* for men and women.⁷

A woman who is *namussuz* is by definition bad, whereas opinion is divided with regard to a man who is thus labelled. On the one hand, he is perceived as bad because a man should confine his attentions to his own wife; on the other hand, he is considered very bold and daring. His many amorous conquests accord him *şeref*, provided that he keeps away from girls in his own village or neighbourhood. Should he turn his attentions to them, however, his conduct is no longer glossed over. The labels *zampara* or *çapkın* are replaced by the highly critical epithet *ırz düşmanı* (enemy of honour). Both women and men who are labelled *namussuz* may fall victim to an honour killing.

In contrast to male victims of honour killings, female victims are almost without exception killed by members of their own family, whether related by blood or by marriage. The victim may have married into the family, as in the Dursun case study, or be a blood relative, such as a daughter. We may wonder how a family could possibly kill its own flesh and blood. By definition, states Kressel, such a killing involves a terrible crime or taboo.⁸ It seems to me that killing a daughter would be difficult in the extreme, given the bond that exists between parents and children. Moreover, it is an admission of failure on the part of the family: the girl's dishonourable behaviour shows that she was not brought up properly. For these reasons, if an honour killing is deemed necessary, the family will almost certainly opt to kill the male transgressor. In this way, the daughter is spared and the family saves its reputation.

Kressel gives two reasons why female blood relatives are the victims of honour killings. Firstly, the killing is then an internal family

matter; it is easier than killing the man.⁹ Secondly, it acts as a deterrent to other women in the family who will think twice before behaving in a way that compromises their *namus*.¹⁰ With regard to the second reason, the honour killing is then tantamount to an admission that it is the only way to prevent other daughters from following in their sister's footsteps. If Kressel is suggesting with his first reason that the woman is an easier victim simply because she is at hand, I should point out that the level of difficulty does not seem to be an obstacle when it comes to honour killings. Where necessary, people are prepared to lie in wait for days (the Barut case study), or to undertake a trip abroad (the *Türkmen* case study).

Perhaps Kressel means that killing a daughter has fewer repercussions than killing the man involved, as the latter option may unleash a vendetta. If the daughter is killed, no blood feud will result because there is not a single blood relative who will avenge her: after all, she has been murdered by her own blood relatives. A disturbing example here is the *Tekin* case study. When *Tekin* killed the man who compromised his daughter's honour, another daughter told the police: "What happened last night came as a surprise to me too. My father has always blamed my sister for everything. He never said that he would do anything to the man. If he'd killed my sister, I would have understood and wouldn't have minded so much. After all, she was the one who brought shame upon our family. Now I'll always be afraid of that man's family – I'll be expecting them to avenge themselves on us."

Unlike an honour killing that involves a daughter, the family fears a blood feud when a wife is killed as she has blood relatives who may avenge her. This is what happened in the *Dursun* case study, when the father and the brother threatened to avenge *Zeynep*'s death. The risk of this happening is minimised, however, if the woman is killed by her own son. Because the son is her blood relative, other blood relatives are more likely to respect the deed and to forgo vengeance. We encounter an example in the 1976 novel, *Yılanı öldürseler*, by the Turkish writer *Yaşar Kemal*. The son is urged by his dead father's blood relatives to kill *Esmé*, his dishonourable mother. They are afraid to kill her themselves because *Esmé*'s brothers may seek retribution. They are convinced that no act of revenge will follow if the son kills her.

A further reason for killing the woman rather than the man is revealed in the *Dursun* case study. Because adultery was involved, both the woman, *Zeynep*, and her lover, *Ali Eralp*, should have been

killed, but Zeynep was the sole victim. Serpil, her sister, was very upset about this. Over the phone, she told Zeynep's ex-husband, Kemal Dursun: "If you were real men, you would have killed them both. If you'd done that, my father says he would kiss your penis, not your forehead." In a subsequent telephone call to Gökhan Dursun, Kemal's brother, she continued in the same vein: "Since you killed her, you ought to have killed the man too."

However, Kemal Dursun probably had reasons for not killing his wife's lover. The fact that his wife had a lover would have been a disgrace for a young man like Kemal. There is a widely held belief among Turks that a woman takes a lover because her husband can no longer satisfy her. What made matters worse for Kemal was the fact that his rival was an older, balding man in his fifties. It probably suited Kemal's purpose better to kill only Zeynep, and to justify his action by accusing her of having slept with several men. This laid the guilt fully at Zeynep's door: she was bad and could not stay away from other men. In their statements to the police, the Dursun brothers were very keen to blacken Zeynep's name. The public prosecutor painted a similar picture. In his indictment, he wrote: 'Zeynep had a relationship with Ali Eralp. There are also indications that she had relationships with one or more other men.' However, the only evidence for this are the Dursun brothers' stories and an anonymous letter, which the police suspected was written by Mrs. Eralp. It is understandable that Mrs. Eralp should wish to present matters in this light. She hoped that her husband would be spared and that only Zeynep would be killed. The public prosecutor was unaware that this was a way to 'blacken' the victim's name, thus making the crime less serious for the perpetrator.¹¹

Kressel and Ruggi place considerable emphasis on honour killings within the family. Ruggi deals solely with female victims of honour killings.¹² According to Kressel (1981: 151), male victims, insofar as they exist, are killed by members of their own family. Arabic Muslims in Israel, Kressel's research group, are probably an exception, because he writes: 'Filiacide is not found amongst the others [...]. The special moral code seems, therefore, to be intertwined with the combination of Arabism and Islam.'¹³ It would have been helpful if Kressel had provided more information about the killing of male family members; he only presents case studies in which female family members are murdered.¹⁴ The only explanation Kressel gives for killing a son is as follows: 'Attack on a son who has been discovered in a sexual crime is influenced by the threat of the required dispute

with the family of the girl who has been hurt, particularly when her family is stronger than his.' Here, 'stronger' means 'higher social position'. 'Decision taking is influenced by aspirations to social mobility [...]. Murder can enhance prestige and is like a planned investment in improving [...] social status'.¹⁵ This suggests that a son is killed because he has tarnished the *namus* of a young woman from a higher social class, which will not benefit his family's social aspirations. However, Kressel does concede that the killing of a son is rare: 'nonetheless, the customary law is exercised with relative infrequency for rapists and sexual seducers. Strong groups support their sons even if they have been accused of rape or seduction.'¹⁶ This explanation seems the more likely. The boy's family will claim that the girl was not raped, but that she seduced their son.

I would not classify the killing of a male blood relative because of improper conduct as an 'honour killing'. The family's *namus* – in other words, the chaste behaviour of its female members – is not at issue here. This would only apply if the man or boy had committed incest. If the incest becomes known, enormous pressure is brought to bear on the men in the family to take revenge on the man responsible. Deug writes that if a man abuses his daughter, his sons may want to kill him.¹⁷ Tezcan cites an example of a request to kill a son for violating honour: 'Mehmet Yıldırım's son Hasan (aged 17) tarnished the honour of Ahmet Doğan's daughter and fled for fear of the consequences. Ahmet Doğan then demanded that Mehmet Yıldırım kill his own son, but Mehmet Yıldırım said that he could not do it.'¹⁸ In his research village in the Black Sea region, Schiffauer reports that young men and women meet in secret before marriage. But if word of these meetings leaks out, the young man is threatened by his brothers. Schiffauer gives no further explanation as to why this is the case.¹⁹ Are the brothers afraid that the girl's father will kill their brother and are they threatening him for his own good, or do they fear blood revenge, which will endanger their own lives? Tezcan chronicles this second possibility. A son who violates the *namus* of a girl in Urfa is punished, warned or reprimanded, because people know that violating the honour code can lead to an honour killing, which in turn can spark off blood revenge.²⁰

When a female family member becomes the subject of scandal and is killed, this is referred to as purifying the family's *namus*. If the woman or girl is not to blame for the loss of *namus*, she is 'defiled' (*kirlenmiş*); if she is partly responsible, she is both 'defiled' and 'dis-

honourable' (*namussuz*). However, she alone does not enter into a state of defilement; the members of her family share in it. The anthropological term for this is 'pollution'.²¹ By killing the man who violated her honour, the family cleanses its *namus*. When the dishonourable woman is killed, she is not cleansed; instead, she disappears, she ceases to exist. She is no longer part of the family and can no longer pollute it. By eliminating her, the family has 'cleaned' its *namus*, to translate literally from the Turkish. Killing a dishonourable woman is called 'cleaning up the filth' (*pisliğin temizlenmesi*), as was said about the girl Seveda, in the case study 'Knifing in the square'.

The question arises as to whether the sisters of a murdered girl are stigmatised because their sister was *namussuz*. After all, people believe that what one sister does, the others will do too. This may explain Serpil Dursun's anger when she learns of the death of her sister Zeynep. She asks the Dursun brothers why they could not have arranged it differently – a car accident for instance. This would have disguised the fact that it was an honour killing. It would be interesting to investigate the extent to which girls are affected by the honour killing of a sister. I suspect this is not a problem for Serpil Dursun, who lives in Turkey. Popular opinion will say that Zeynep was exposed to bad influences in the Netherlands.

It is more difficult to see where 'cleansing' comes in when the man is killed instead of the woman. Killing the rapist will not restore the girl's virginity, so how can the honour killing purify *namus*? However, raising this question can cause resentment among Turks who are convinced that the family's *namus* has been purified. According to the criminologist Yeşilgöz, in the event that the transgressor is killed, only the *namus* of the father and other members of the family is purified; the daughter herself remains without *namus*.²² He made this statement in response to the 'Denmark' honour killing in which Songül Çağlar, a thirteen-year-old Kurdish girl, was abducted from her home village of Kerpiç by Fevzi Çağlar, the son of her father's brother, and unceremoniously returned a month later. Her father killed Fevzi's older sister, whom he held responsible. I wondered whether the girl had since married and on 30 August 1997 I went with my Turkish husband, Bahadır, to investigate. When we enquired at a petrol station about the village of Kerpiç, we were advised to go to the nearby town of Haymana where many of the villagers from Kerpiç were celebrating the circumcision of a village boy, Ali. The boy's uncle (his father's brother) was quite wealthy and was

hosting a large celebration in Haymana, where he lived. After joining in the *halay*, a traditional dance, we went aside with Hasan Yıkılmaz, a former inhabitant of Kerpiç, and enquired about Songül. He told us that Songül, now twenty-four years old, had been married for several years and had two children. She had not been married off in haste to a man from afar, nor to a widower, or a man with an infirmity or a relative who was willing to take the shame upon himself. Instead, she married in due course a decent man (*efendi bir adam*) from the village and was still living in Kerpiç. Hasan Yıkılmaz asked us not to go to Kerpiç and remind Songül of the terrible episode from her past and we respected his wish. We had the information we were looking for: Songül was doing well and had not been stigmatised by the village. According to our informant, she was no longer *namusu kirlenmiş* after the honour killing, but simply *namuslu*.²³ By killing the male transgressor (or a member of his family), a girl's *namus* appears to be restored, together with her marriage prospects.²⁴ It should be pointed out that this applies to a girl who has lost her *namus* against her will. Songül was 'tarnished' (*namusu kirlenmiş*) but not 'dishonourable' (*namussuz*).²⁵ There is a solution, however, for girls who are *namussuz*: the rape claim.

2.2. Rape claims

Rather than admit that a daughter is having a relationship, a family may claim that she was raped. This then requires the family to kill her boyfriend, the 'rapist', and not the young woman herself.²⁶ Newspapers sometimes refer to this as a 'rape puzzle' (*tecavüz bilmecesi*). Women and girls may also use this excuse themselves. When their shameful conduct is discovered, they can exonerate themselves by saying that they were raped. Often the husband and other family members are aware of what actually happened, but they maintain this version of events to legitimise an honour killing of the honour violator. In emotional terms, many families are probably not capable of killing a female blood relative. Nor would it be in their economic interests to lose a female family member, particularly a wife. In the honour killings that I investigated, the victim was usually the man, and the woman – a blood relative – was spared.²⁷ In some instances, recourse was made to a rape claim, as in the Çetin case study.²⁸

THE ÇETIN CASE STUDY: 'AT SUMMER CAMP' (1988)

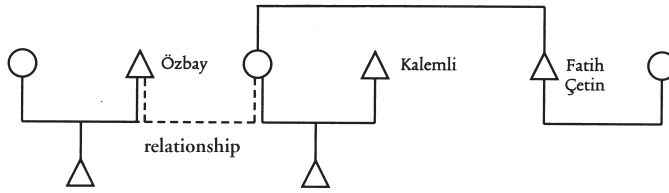

Fig. 2: The Çetin case study

The Kalemlis and the Özbays, two Turkish families, are very good friends. Their sons are in the same class at school. Kalemli came to the Netherlands after his marriage but cannot find work. His wife, who grew up in the Netherlands, earns a living doing welfare work. Through her job, she has a great deal of contact with Özbay, chairman of a Turkish organisation. In 1987, there is a three-day summer camp for children and their parents. Mrs. Kalemli and Özbay each accompany their sons. Because the menu consists entirely of pancakes, chips and macaroni, on the last day of the camp, Mrs. Kalemli and Özbay offer to do the catering for next year's camp. So in spring 1988, all participants receive a letter stating that Mrs. Kalemli and Özbay will jointly provide the meals. This news goes down badly with Kalemli: his wife and Özbay! It all but confirms the suspicions he already has. He questions his wife and she admits that she was raped by Özbay at the summer camp the previous year. Fatih Çetin, Mrs. Kalemli's brother, subsequently kills Özbay.²⁹

Mrs. Kalemli told the police that she was raped on both nights of the three-day summer camp, but that she did not dare tell anyone, as she did not want it to become public knowledge. However, there are indications that it was not rape but an affair. If she had been raped, it is inconceivable that she should want to share responsibility for the meals with Özbay the following year. Various witnesses stated that the suggestion about the meals came from Mrs. Kalemli herself. Moreover, a Dutch manager of the holiday camp said that immediately upon arrival Özbay and Mrs. Kalemli went with their two children to reserve two rooms that were separate from the others. Other parents and children went to the two large dormitories. The witness stated: "I warned them about those two rooms. They're noisy and

smoky because of the open fire [...]. If Mrs. Kalemli had wanted another place after the first night, it would have been possible. There were plenty of beds. She could have used the noise and smoke as an excuse.” In other words, if she had wanted to, Mrs. Kalemli could easily have avoided the second night with Özbay. According to the same witness: “Mrs. Kalemli and Mr. Özbay and their children also went off together in the same car on the second day. I got the impression that Mrs. Kalemli and Mr. Özbay liked one another.” Another Dutch witness stated: “I saw no signs of a dispute between Mrs. Kalemli and Mr. Özbay (...). They didn’t avoid one another during the day either.”

The question is whether Kalemli gave any credence to the rape story that his wife told him. Probably not, in view of what he said to Mrs. Özbay, the wife of the ‘rapist’: that his wife may have been willing, but that her husband should still not have done it. Kalemli probably knew that his wife was guilty but he called the man to account. This attitude is not uncommon in more traditional parts of Turkey. The expression ‘a woman’s hair is long and her intellect short’ (*kadının saçını uzun, aklını kısa*) means that, although beautiful, women have no sense and cannot resist temptation. It is up to the man to reflect and to keep away from another man’s wife.

Ali Eralp, Zeynep’s lover in the Dursun case study, was aware of the ‘rape’ excuse. He recorded their encounters on tape as proof that Zeynep was having sexual intercourse with him of her own free will. This would not prevent him from being killed – in the case of adultery both parties are guilty – but it meant that Zeynep could not exonerate herself, and would therefore not publicise their relationship.

2.3. Honour killing of newborn babies

Not only women and their seducers fall victim to honour killings. Other victims include newborn babies, generally children born out of wedlock.³⁰ Because nobody must know of the child’s existence, the baby is killed in secret to prevent injury to the family’s *namus*. The perpetrators of this crime are eligible for a reduced sentence.³¹ I have encountered the following honour killings of babies in the *Hürriyet*. An unmarried girl was kept indoors by her family so that no one would learn of her pregnancy. The baby was killed shortly after birth.³² Three other girls hid their pregnancy from everyone and killed the babies at birth.³³ A widow and her lover killed their baby so that their adultery would not come to light.³⁴ On some occasions, the

girl was murdered while still pregnant with an illegitimate child.³⁵ On others, only the girl was killed and the baby was spared because the family could not bring itself to kill it.³⁶ We can only speculate on the life in store for such a baby.³⁷

In October 1988 in the Netherlands, a Dutch doctor was only just in time to prevent a case of infanticide in a Turkish family. The case involved baby Fatima, whose mother was a 15-year-old unmarried Turkish girl.³⁸ The birth took place at home without the assistance of a doctor or midwife. However, a doctor had to be called in because of complications. After the birth, the girl's father said that the baby had to die: no-one in the neighbourhood knew that the girl had been pregnant and no-one must ever find out. The doctor was able to take the baby to the hospital on the condition that he give no information about the mother. The baby eventually ended up with foster parents.

I suspect that there were two instances of infanticide in my research, or at least of induced miscarriage. In both the Altuğ and Uzun case studies, the pregnancies of the unmarried girls officially ended in a miscarriage. This would appear to be no coincidence, all the more so as it suited the family's purpose very well – what would they have done with a baby? In both cases, the girl's father killed the man – the baby's father – who had compromised his daughter's honour.

2.4. Honour killing of a member of the honour violator's family

Members of the male transgressor's family may also fall victim to an honour killing. This occurs in accordance with the notion of blood revenge, whereby someone from the man's family must be killed. The victim may be the father, who is held responsible for his son's conduct, as happened in the Yiğit and Koparan case studies. The father was also the victim in the incident from Tezcan cited earlier. After Mehmet Yıldırım's son had raped Ahmet Doğan's daughter and fled, Ahmet asked Mehmet to kill his own son. When he refused, Ahmet killed Mehmet, his best friend, with four gunshots.

According to Breteau, when the male transgressor cannot be found, a family member is killed instead.³⁹ The victim may be a brother, as in two examples from the *Hürriyet*. When the newly-married Ülkü eloped with her ex-fiancé Dursun Iri, his two brothers were killed. The police suspected Kürşat Yılmaz, the girl's father, of hav-

ing committed the murder.⁴⁰ In the second example, Kazım and Hacer eloped. The brother of Hacer (the girl) then shot Kazım's brother.⁴¹ Safilios-Rothschild notes that children are sometimes selected as victims of honour killing, although I did not encounter any instances in my research.⁴² In the Dursun case study, however, the children of Zeynep's lover, Ali Eralp, were afraid that they would be targets of an honour killing. They lived in fear that the Dursun brothers would try to get at their father through them, which shows that Turks accept the possibility that even the children of the male transgressor may be killed. Nor is it only male family members who fall victim to honour killings. Females are potential targets too, as in the 'Denmark' case study, in which the victim was the sister of Fevzi Çağlar, the abductor and rapist.

'HONOUR KILLING IN DENMARK' (DOCUMENTARY, 1986)⁴³

Resul and Yusuf are Kurdish brothers. Resul lives with his family in Kerpiç, a village in the district of Haymana, southwest of Ankara. Yusuf moves with his family to Hasanoğlan, a village on the outskirts of Ankara, where many migrants from the countryside live. Resul has six sons and two daughters. From what we can learn from the documentary, Yusuf has at least one son and two daughters. Resul's son Ali has married Yusuf's oldest child, his daughter Gülsüme. Ali and Gülsüme move to Denmark, where two children are born.

A second marriage follows between children of the two brothers: Meryem, Resul's daughter, marries Fevzi, Yusuf's son. This couple also wants to go to Denmark. Meryem is the first to emigrate, about three months after the wedding, and she goes to live with Gülsüme, who is since divorced from her husband Ali, Meryem's brother. The plan is for Fevzi to follow later.

Once in Denmark, Meryem begins a relationship with another man. Fevzi, who is still living in Hasanoğlan, is furious and decides to avenge himself by abducting Meryem's youngest sister, the 13-year-old Songül. On 9 August 1986, Fevzi abducts Songül from her home village of Kerpiç as she walks from her house to the village pump. He is helped by his sister Halise, who talks Songül into their car. More than a month after the abduction, Songül, no longer a virgin, is brought back home. Resul demands that Fevzi marry Songül.⁴⁴ He refuses. Eventually Fevzi is imprisoned for abducting an under-age girl. On 24 October 1986, Gülsüme (aged 31) is killed, having

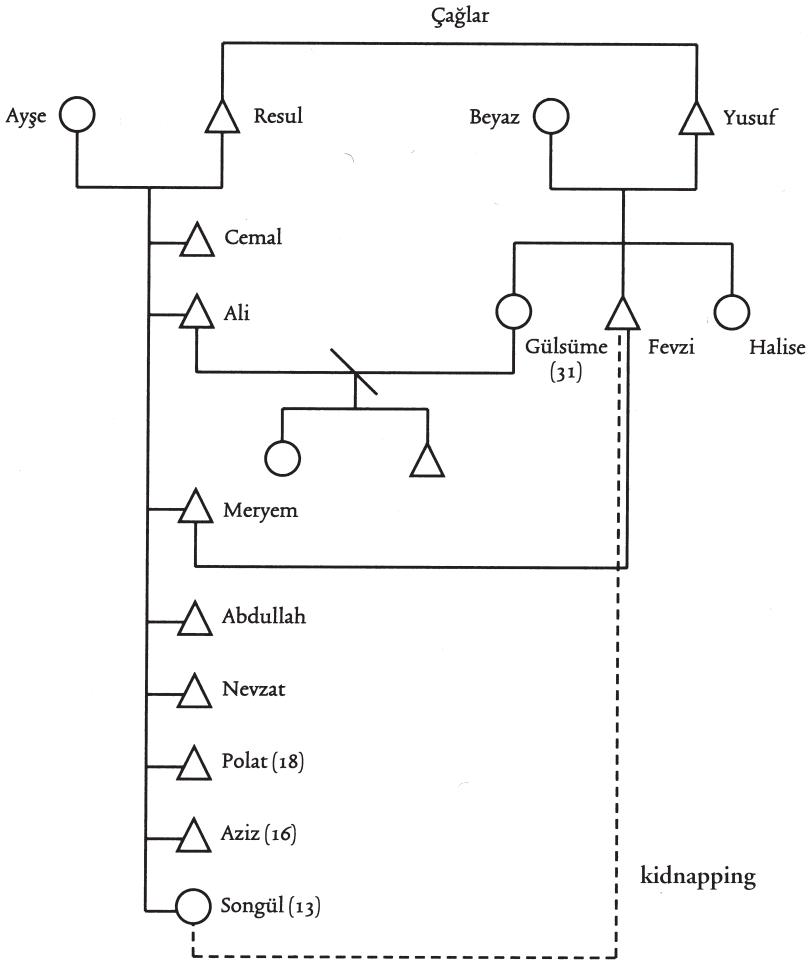

Fig. 3: The 'Denmark' case study

been stabbed twenty-nine times by two of Resul's sons, Polat (aged 18) and Aziz (aged 16).

Why was Gülsüme murdered? According to Resul, she had planned the abduction and had led his daughter Meryem astray, with the result that Meryem was unfaithful in Denmark to her husband Fevzi.⁴⁵ Resul's low opinion of Gülsüme is understandable given that she had divorced his son, Ali. According to the criminologist Yeşilgöz, there was a further reason why Gülsüme was selected as the victim over and above another member of the family: she provided the in-

come for Yusuf's family in Hasanoğlan.⁴⁶ Her death would hit the family hardest, thus punishing the entire family for Songül's abduction.

There may also have been a pragmatic reason. Resul may have chosen another member of the family because Fevzi, Songül's abductor, was in prison and hence difficult to kill.

2.5. Multiple honour killings

Occasionally, not just the male transgressor and/or the dishonourable woman are the victims of honour killings, but members of their family as well. The *Hürriyet* refers to such instances as 'honour massacres' (*namus katliamı*). A very dramatic example was the massacre in the Esenler suburb of Istanbul on 20 October 1996, in which ten people were killed. This was extraordinary, even by Turkish standards, and the incident made the front page of all the papers the following day.⁴⁷ The sisters, Nuran and Aycan, had run away from their husbands, Abdullah and Celal, who were brothers, and went to live with their mother. The brothers then went to their mother-in-law's house where, with the assistance of a friend, they killed their wives, their mother-in-law, three sisters-in-law and a brother-in-law. The five-year-old daughter of Aycan and Celal was also killed. Abdullah had removed his own three children from the house just before the massacre.⁴⁸ Bünyamin and Attilah, two brothers aged 27 and 26 who were in the house at the time, were also killed. They were said to be boyfriends of Nuran and Aycan. The sisters had a reputation in the neighbourhood as 'prostitutes' (*hayat kadını*).⁴⁹ Abdullah and Celal probably embarked on this wholesale massacre of their in-laws out of a desire to punish them: their mother-in-law and other members of the family had tolerated Nuran and Aycan's dishonourable behaviour.⁵⁰

It is not uncommon to hear reports of a son-in-law storming into his parents-in-law's house because his wife has gone back to live with her parents. If the wife is unwilling to return, a bloodbath may result. The headlines then read 'son-in-law terror' (*damat dehşeti*).⁵¹ Often, the son-in-law has had too much to drink. Murder is not always the end result, sometimes just injury. Often, the son-in-law has not come to kill, he simply wants his wife to come home. If the woman is killed, this does not constitute an honour killing but rather murder or manslaughter for reasons of male pride. The wife does not have a

lover, she has simply left her husband because she could not bear to live with him any longer (see 5.6).

2.6. Honour killing of an implicated third party

We have seen that members of the male transgressor's family may be killed if they are held responsible for the attack on honour (the 'Denmark' case study). Similarly, in the case of multiple honour killings, family members may be killed because they are seen to share the blame. The Utlu case study shows us that there are other potential victims: Utlu killed the female friend of his wife because he was convinced that she had led his wife astray.

THE UTLU CASE STUDY: 'DEATH ON THE PHONE' (1990)

Kemalettin Utlu, who grew up in the Netherlands, is married off at the age of twenty-two to a young woman from the Turkish village where he was born. She is brought to the Netherlands. However, the two do not get on well and six months later Utlu ends the marriage. Both his parents and his parents-in-law are furious. A short time later, Utlu meets a new girlfriend, Çiğdem, who is only fourteen years old. His parents are opposed to the relationship and have no further contact with him. Because the couple plan to live together without being married, the Turkish community in the Dutch town where Utlu lives interferes as well. But Utlu continues to resist marriage; nor does he wish to restrict his girlfriend's freedom. He doesn't mind how often she goes out in the evenings. A few years later a daughter is born.

After they have been living together for three years, Çiğdem starts working for a company that supplies agricultural labourers, a job she obtained through a girlfriend, Filiz. Çiğdem begins a relationship with Osman, her boss. She spends the days with her new boyfriend and barely needs to work. Utlu becomes suspicious because Çiğdem is never tired in the evenings after a day's work. She finally confesses that she is having an affair and says that she wants to end it. He forgives her and they decide to make a fresh start. It emerges a few weeks later that she is pregnant. She doesn't know who the father is, Osman or Utlu, and they decide that she should have an abortion. Çiğdem continues staying out late, which is a constant source of strife between them. Eventually Çiğdem leaves and goes to a reception centre. She has constant telephone contact with her girlfriend Filiz, who advises her on which women's refuge to choose. Utlu, who suspects that Filiz knows

where Çiğdem is staying, keeps going to her flat to ask where she is. She doesn't let him in, but speaks to him through the intercom. After a time, she even stops answering the doorbell. He becomes desperate, not knowing whether she is at home or not.

Finally, Utlu takes his best friend Haydar into his confidence. Together they go looking for Çiğdem in Haydar's car. As he told the police later, Utlu becomes increasingly distraught during the search because: "No matter who I met, they'd start going on about my girlfriend and saying all kinds of things. They would make comments that attacked my honour. They said my girlfriend was making a fool of me and that there'd been other men besides Osman." The last straw is the behaviour of Metin, the owner of the coffee-house. When Utlu urges him to tell him everything he knows about Çiğdem, Metin takes Utlu aside and tells him it is his own fault. Utlu should have been stricter with Çiğdem. "A man must be the boss over his wife," says Metin, who tells him that he knows everything about Çiğdem's relationship with Osman and about the abortion. This last piece of news comes as a slap in the face to Utlu, who thought that no one in the Turkish community knew about the abortion. Haydar later tells the police that Utlu was totally distraught after this tête-à-tête with Metin. He broke down and drank two glasses of whisky.

At the coffee house, they decide that Metin, who knows Filiz, will try to find an opportunity to talk to her. Utlu and Haydar will accompany Yücel, a friend of theirs, to Yücel's house, where his flatmate has a gun. They will ask to borrow it and will then go to Osman's to bring Çiğdem back. Utlu tells the police later that the pistol was intended to threaten Osman into relinquishing Çiğdem.

The moment that the three men leave Yücel's house (Utlu has the gun in his pocket), Metin drives up and announces that Filiz is at home. They all drive to her flat. Utlu presses the doorbell and, much to his surprise, the buzzer sounds and he is able to open the street-entrance door. He runs straight to the door of her flat, which also opens immediately. It emerges later that this was due to a misunderstanding. Metin, whose family is good friends with Filiz's family, has sent his little brother, Mehmet Ali, to Filiz's flat to see if she is at home. Because she knows him well, Filiz lets Mehmet Ali in. Once inside, he phones Metin to say that he is at Filiz's place. Metin says that he'll be right over. So when the doorbell rings a short time later, Mehmet Ali assumes that it is Metin and he presses the buzzer without enquiring through the intercom who it is. He opens the door to the flat as well. If Filiz had not been talking on the phone, she probably would have stopped him.

When Utlu sees the open door, he rushes inside and spies Filiz talking on the phone. He immediately puts the gun to her temple and says: “Tell me where she is or I’ll kill you.” But Filiz doesn’t respond. He grabs her by the throat to give his words more emphasis. She still doesn’t respond. Utlu told the police later that he then pulled back the trigger – as the ultimate threat – but the gun went off. Filiz falls backwards. She manages to tell the friend she had been talking to that she has been shot. The friend immediately calls an ambulance, but Filiz dies on the way to the hospital.

Utlu runs outside, where he acts the tough guy. After all, his Turkish friends are there as well as the owner of the coffee house. “So, the filth has been cleaned up,” he says and gets into Haydar’s car. His friends, Metin and Yücel, understand at once what has happened. They panic and drive off. Haydar drops Utlu off at a café: he doesn’t want to have anything more to do with it. Utlu has a drink and takes a taxi to the police station where he gives himself up. According to the police report: ‘A man came into the police station. He threw his brown leather jacket onto the counter. We saw that the man was extremely upset and was crying. We heard the man say: “I’ve killed someone. I’ve killed someone. The gun’s in my coat.” Utlu is sentenced to six years’ imprisonment for manslaughter.

I initially categorised this killing as an ‘honour killing of the wrong person’. However, Utlu’s words after the event reveal that this was not necessarily the case. He said: “The filth has been cleaned up,” and his friends knew instantly what he was referring to. He regarded Filiz as ‘dishonourable’ (*namussuz*): she had his wife’s dishonour on her conscience. His parents’ response to the incident makes it clear that they saw it as a successful honour killing. Because of Utlu’s divorce and the fact that he was living with another woman, they had wanted no contact with their son for years. But when he was awaiting trial after the honour killing, they came to visit him and were full of praise for his actions. Utlu told the probation officer that he did not appreciate this response from them. He was very upset about what he had done. When reconciled with Çiğdem, his girlfriend, who promised to be eternally faithful, Utlu was sceptical, believing that a young woman like her would not wait until he was released from prison.

Honour killings of third parties are rare. Nevertheless, the fear of being killed is very real. People think twice before becoming involved with a young woman whose *namus* has been compromised. One man who did become involved was Metin Yıldız, a Turkish social worker living in the Netherlands. When he helped find a safe address

for a Turkish girl who had run away from home, the girl's family accused him of having a relationship with her. Metin Yıldız was killed after being shot in the head with six bullets. The killer was probably the girl's father, but this was never proven.⁵²

2.7. The wrong person is killed

Sometimes, inadvertently, someone other than the intended victim is killed. Twenty-year-old Murat Çetin planned to kill Kazım Kısa, his married sister's boyfriend, but he killed Kazım's brother by mistake.

CASE STUDY: 'HONOUR KILLING OF THE WRONG PERSON' (HÜRRIYET, 1995)⁵³

Murat Çetin lives in Yenibosna, a northeastern suburb of Istanbul. His older sister, Sevcan Çetin, is married in an imam ceremony⁵⁴ to Taci Bozdağ. Sevcan falls in love with Kazım Kısa and leaves her husband, but returns to him five years later. There is talk that she is pregnant by Kazım. Murat visits his sister and asks her how she could have done such a thing. According to Murat, she replied: "Ask that p... [pimp] there," referring to her husband. Her husband then says to Murat: "Sana ne ulan...namus benim, boynuz benim." (What's that got to do with you? It's my namus, they're my horns).⁵⁵ Murat shoots them both. He then goes to the neighbourhood coffee house where he plans to shoot Kazım Kısa. Kazım is not there, but Murat mistakes Kazım's brother, Dilaver Kısa, for Kazım and shoots him instead. İsmet Aydın is drinking rakı with Dilaver. On the assumption that 'anyone in such company is just as bad' (O alçakla oturan alçaktır), Murat shoots him too. Three other men sitting there are also injured in the hail of bullets let loose by Murat. According to Kazım Kısa, Murat's father's brother (dayı) was behind the shooting.

The killing of Dilaver Kısa constitutes an 'honour killing of the wrong person'. Murat Çetin clearly did not intend to kill him. Murat did not regret murdering his sister and brother-in-law, but he did apologise for killing Dilaver Kısa and İsmet Aydın, and for the injuries he caused to the other three men.

2.8. Failed honour killing

Honour killing attempts are usually carried out so systematically that they are successful and result in the death of the intended victim. However, in February 1998, the *Hürriyet* described an incident in which the victim, a newly-married woman, survived. The woman reported the murder attempt to the police, which was so unusual that the newspaper continued to cover the issue for days afterwards. The failed honour killing proceeded as follows:

CASE STUDY: 'THROWN INTO THE EUPHRATES' (HÜRRIYET, 1998)⁵⁶

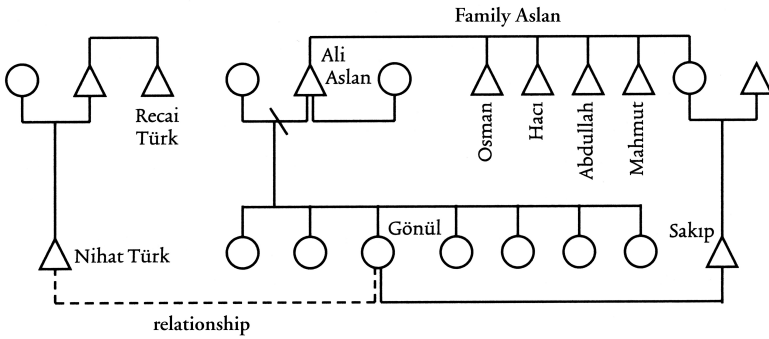

Fig. 4: Case study: 'Thrown into the Euphrates'

Gönül Aslan, a 19-year-old Turkish woman,⁵⁷ was born and bred in the seaside resort of Antalya. Her family, who originally came from Viranşehir in Urfa Province, is part of a clan (aşiret). Her father, the 49-year-old Ali Aslan, is an employee at the Public Works Department (Bayındırlık Iskan Müdürlüğü), where he has worked for the past 25 years. The mother has left the family and lives in Ceyhan in Adana Province. The father has remarried and lives with his seven children in a slum area (gecekondu), as do many migrants from rural areas. Gönül, the third child, does not get on well with her stepmother. She has stopped attending school and has various jobs so that she can contribute to the family income. Her father and stepmother are not happy about her conduct. She dresses in modern clothes, wears make-up, and regularly swims at the tourist beach near Konyaaltı Plajı. When they

learn that she has a boyfriend, they decide to marry her off as quickly as possible.

Gönül is in love with the neighbour boy, Nihat Türk, who works in a hotel in Kemer. All the same, she is married off in December 1997 to Sakıp, the son of her father's sister, to whom she was promised when still a baby (beşik kertmesi halasının oğlu) and who lives in the village of Uçkilis köyü near Viranşehir. The wedding is held in Uçkilis köyü, after which Sakıp and Gönül go to live in Antalya. Gönül is very dissatisfied with her husband and calls him 'a real village boy'. She complains to her father, Ali, that she can't bear to live with Sakıp any longer. Her father calls in Sakıp, who tells him that Gönül doesn't lift a finger at home: she doesn't even prepare meals. Ali becomes furious with his daughter when he hears this and says: "May God punish you. You have a very good husband. What is your problem?" In tears, she replies: "I don't love him. Did you consult me about the marriage?" The father asks his son-in-law to be patient with Gönül: "She's not a village girl. She grew up in the big city, but she'll get used to you."

However, Gönül runs away from her husband and goes to stay with a girlfriend in the village of Göynük near Kemer. The whole family goes looking for her. Sakıp goes to Ceyhan, thinking that Gönül might be at her mother's. Gönül's disappearance becomes public knowledge. The leading members of the clan telephone her father, Ali. The gossip intensifies. One day Gönül is discovered in Göynük by her uncle Hacı. She flees and goes to stay with her boyfriend Nihat in a hotel. For fear of discovery, they flee from the south coast to the west coast and seek refuge in a hotel in Söke, in the province of Aydın. Nihat phones his uncle Recai to ask for money and clothes. Uncle Recai comes and persuades them to return to Antalya. He then talks to the Aslan family and tells them he has found the couple. He says he will pass on the address, provided the family promises not to do anything. Uncle Recai hopes that the affair will soon fizzle out, but the family goes straight to where Gönül and Nihat are staying and brings Gönül back.

When they get home, Ali Aslan, his four brothers Osman, Hacı, Abdullah, and Mahmut, and his son-in-law, Sakıp, hold a family council. The father's brothers live in different places: Hacı is a farm labourer in Antalya, Mahmut lives in a village near Viranşehir, Abdullah lives in Ceyhan and Osman in Gaziantep. They quickly decide that Gönül must be killed, but the question as to how this should be done takes somewhat longer. Nobody wants to receive a long prison sentence. They reject the idea of throwing her under a truck: they would feel sorry for the driver. Mahmut then suggests taking her to his village (near Viranşehir) so that his son Ali, who is seventeen, can shoot her. "We'll say that it was an accident, and he's a minor, so he'll get a lighter sentence." They agree that this is a good plan. Ali

hires a car and the four brothers, Hacı, Mahmut, Abdullah and Osman, drive Gönül back – a journey of 1,000 km. Sakıp will find his own way of getting back to his village. En route, as they pass Gaziantep, Osman says that he doesn't feel well and he gets out of the car. This may be his way of getting out of the honour killing. When they reach the village, Mahmut calls Ali, his son, and tells him what he has to do. But Ali doesn't want to. He says: "I can't kill anybody. It's a sin", and he flees the house.

They then come up with another plan. They decide to drown Gönül in the Euphrates River so that it will look like suicide. Late at night, the three brothers accompany Sakıp and Gönül in the car and stop by the Euphrates in the district of Birecik. Uncle Abdullah and Gönül's husband, Sakıp, strangle Gönül in the car by wrapping her scarf around her neck and each pulling one end. They then drag her out of the car and throw her into the river. When Uncle Mahmut shouts: "She's still alive," Sakıp gives her a hefty kick and her body drifts away down the river.

But Gönül is not dead. She comes to as she hits the ice-cold water. When she hears her uncle say that she's still alive, she keeps absolutely still. She is kicked further into the river. But unlike village girls in Viranşehir, who cannot swim, and unknown to Gönül's uncles and husband, she is a very good swimmer. It is a skill she picked up at the beach resort of Antalya. Once her uncles and husband have gone, Gönül swims through the icy water to the riverbank and walks to a petrol station, where she calls the police and is taken to hospital.

The husband, father and his four brothers were arrested. Ali, the father, claimed he knew nothing of the attempted honour killing of Gönül: he had called his brothers to Antalya to have them take Gönül back to her husband. Ali said he was happy his daughter was still alive. Uncle Hacı, on the other hand, immediately admitted his involvement to the police. He said he had no regrets and was sorry that she had survived: "If only she'd perished. We're not sorry. It was a question of honour. May God punish her" (Keşke geberseydi. Pişman değiliz. Namus davası. Allah belasını versin). Uncle Osman and Ali were acquitted and the others were let off with a light sentence (see 2.10).

Ali told journalists: "From this moment, my family disowns my daughter. She must stay far away from us" (Kızım artık bizim ailede lanetlendi. Bizden uzaklaşsın).

The governor of Urfa placed Gönül under protection at a secret address where she could stay until able to provide for herself. She broke up with her boyfriend Nihat. She could not get over the fact that he had done nothing when her family came to collect her. She said: "Nihat left me to my fate. He

left me alone in the hands of those executioners. I don't love him anymore."⁵⁸

That was the first time I came across an instance of a failed honour killing of a young woman in the *Hürriyet*. Kressel observes that women and girls who survive an attempted honour killing do not wish to testify against their family.⁵⁹ Perhaps other failed honour killings in Turkey have not made the headlines because the girl did not lodge a complaint. In the 'Euphrates' case, Gönül did file a complaint, but only against her father's brothers and her husband: she refused to believe that her father was involved.⁶⁰

There are other reasons why an honour killing may fail: the intended victims may defend themselves and kill the attacker. The following examples were reported in the *Hürriyet*:

A newly-married young woman of sixteen told her husband that she was raped by her uncle. Her husband's father then summoned the uncle for questioning. During the interview, the uncle killed both the father and the son with a hand grenade.⁶¹

The Demirs and Özyalçın went with their small children to visit Lütfü, a bachelor and mutual friend. As they were leaving, Mrs. Demir told her husband and the Özyalçın that Lütfü kept touching her. Özyalçın then questioned Lütfü. A fight ensued. Lütfü grabbed a knife from the kitchen and stabbed Özyalçın to death in the presence of his children.⁶²

These incidents reveal the risks involved if a woman complains about an attack on her *namus*. Her husband – or father, or a friend of the family – may feel obliged to act, as occurred in the Sümbül Aslantaş case. Sümbül, a 22-year-old woman from Istanbul, joked to her fiancé⁶³ that a doctor had made indecent advances to her (*sarkıntılık yaptı*). When the fiancé went to the hospital to teach the doctor a lesson, the doctor pulled a gun out of his drawer and killed him. The 'joke' ended with her fiancé dead and the doctor in prison.⁶⁴ Sümbül later admitted in court that she had lied.

A woman's family cannot always be certain that the man in question has in fact compromised her *namus*. All they have to go on is her accusation. In the above cases, the men probably wanted to check the truth of the accusations, but by asking questions they brought about their own deaths. There is a widespread belief that, in order to prevent a question of *namus* from arising, women should have the good

sense to keep such matters to themselves. They thus avoid a situation in which the husband commits an honour killing or is killed himself in the fight, which inevitably follows an interrogation of the man accused.

2.9. The funeral

In the Dursun case study, the victim, Zeynep, was buried in a Dutch cemetery. The Dursun brothers and their wives told the police that this was because her children lived in the Netherlands. But this was not the real reason, as the telephone taps reveal. A heated discussion arose with Zeynep's family in Turkey, who did not agree with their daughter and sister being buried in the Netherlands. It is customary for Turks living in the Netherlands to be flown back to Turkey for burial when they die.⁶⁵ The transcript of the phone call is given as follows in the court records:⁶⁶ 'Ismet Dursun (the father of the victim Zeynep) urges Gökhan Dursun (the brother of Zeynep's husband Kemal) to send the body. Otherwise, he says, they will be a laughing stock. Gökhan says that the victim was not a war casualty, but had been killed for reasons of honour. Gökhan says that the victim let herself be screwed and thinks this is not appropriate [...]. Kemal says she will be buried here [in the Netherlands]. Kemal says: We've done our duty. That's all.' And in a subsequent phone call: 'Gökhan Dursun speaks to Temel (Zeynep's brother) about the burial. Gökhan thinks that a whore does not belong in Turkish soil. But Temel wants her buried in Turkey and is prepared to fight for it. Temel: We just want the body, however bad she may have been. We want the body (...). Gökhan repeats that a whore cannot be buried there (in Turkish soil) because then everyone will say 'That's where the whore lies buried'. Temel suggests that people will still say that if she's buried in the Netherlands.

Gökhan is suggesting that had Zeynep been a victim of war, she would have been buried with full honours. But as a dishonourable woman, she deserves a dishonourable burial. If the Dursuns had meant to do well by Zeynep, they would at least have tried to bury her in an Islamic cemetery in the Netherlands. But there was no such discussion and they clearly made no attempt to do so. Zeynep was buried in a village outside the town where she lived. When the police asked why, the brothers did not reply. Was there a reason for this?

Was she being banished as far as possible? The police attended Zeynep's funeral to see if any of her close relatives came; none did.

Zeynep's funeral was fully in keeping with what we might expect. A dishonourable woman is not given a stylish burial ceremony; she is shown no last respects or, as they say in Turkey, no 'final duty' (*son görevini yapmak*). Nor should we harbour any illusions about the funeral of the dead girl in the following honour killing incident.

CASE STUDY: 'KNIFING IN THE SQUARE' (HÜRRİYET, 1996)⁶⁷

On 26 February 1996, in Urfa in southeastern Turkey, the sixteen-year-old Kurdish girl, Sevda Gök,⁶⁸ is knifed to death by her 14-year-old cousin⁶⁹ Mehmet Tamer, who works in the building industry. The girl, who lives in Sinem Sokak Street⁷⁰ in the slum area of Süleymaniye in Urfa, is the oldest child of a family of eight children. Mehmet slits Sevda's throat in the busy square of Süleymaniye meydanı, right in the heart of the slum area. In a statement to the police, Mehmet says: 'I am upset, but our tradition demands that I kill her.'⁷¹ It was felt that Sevda deserved to be killed because she had kept running away from home over the past four months and hanging around lunchrooms and cafés. In Urfa, these are places frequented only by university students. On one occasion Sevda was allocated a place in a children's home, but her family did everything in their power to get her back. She was returned to her parents, but soon ran away again. For the honour killing, Mehmet has the assistance of Celal and Murat Tamer, two sons of his father's brother. They hold Sevda while he stabs her. Celal and Murat then flee. Although there are many witnesses, nobody reveals the killers' identity to the police. Mehmet claims that the two people, whom he swears he does not know, had not been trying to help him but to stop him. He says that he alone has committed the honour killing. The autopsy reveals that the girl was still a virgin. Mehmet Tamer is initially sentenced to 24 years in prison, but because he is under fifteen years of age, the sentence is reduced to seven years.⁷² Under the provisions of the Implementation of Sentences Act, he will ultimately serve 2 years, 9 months and 25 days of his sentence.

Sevda's family did not even take the trouble to remove their daughter's body from the mortuary.⁷³ She was buried without ceremony by several neighbours in the Bediüzzaman cemetery, with neither her father, her mother, her uncles nor other relatives present.⁷⁴ This case study also teaches us that condolences are out of place for victims of an honour killing. When reporters expressed their condolences to

members of the dead girl's family, Sevda's grandfather became very angry: her death was the clearing up of 'filth' (*pislik*) and there were no grounds for sympathy.⁷⁵ In the case study entitled 'honour killing of the wrong person', Sevcan, the killer's sister, was also denied a funeral. No one came to claim her body from the forensic department.⁷⁶

Two of my case studies involve daughters who, because of the shame they brought upon the family, wrote suicide notes in which they referred to their funerals. In a note to her father, Ayşe Elmas wrote: 'Pay off your debts with the money you would have spent on my funeral. Bury me here [in the Netherlands]. It would be a pity to spend money on having my body flown to Turkey.' This is Ayşe's way of saying that they should not incur any costs for a dishonourable daughter. Her boyfriend arrived just in time to prevent her from committing suicide. When she eventually fell victim to an honour killing, she was buried in the Netherlands. Police reports reveal that no close family members were present at the funeral. She was buried, however, in the part of the cemetery reserved for Muslims.

In the Uzun case study, Meral, a girl who fled to Turkey with her boyfriend and was then abandoned by him there, wrote: 'Father, if you don't object, I wish to commit suicide. If I come to the Netherlands and do it there, it will be very expensive to have me brought back to Turkey. I cannot possibly show my face in your house. If you were to kill me, you would be right to do so. My fate was sealed.' Meral wanted to spare her parents any expense. Experience seems to have taught her that it is impossible to be buried as a Muslim in the Netherlands. These letters reveal that girls know they are not entitled to an honourable burial if, through their own actions, they have failed to preserve their *namus*.⁷⁷

In cases where the male transgressor is killed, he receives an Islamic burial in Turkey (the Akkaya and Çetin case studies), even when the family disapproves of his conduct (the Tekin case study). Only if the family is too poor is he buried in the Netherlands (the Şengül case study). It is obvious why male and female victims are treated differently in this respect. The young woman is killed by members of her own family, whereas the man is not; he still has blood relatives to defend his interests. In the case of a married woman, although she does have blood relatives, they are not always given the opportunity to arrange the funeral, as we saw in the Dursun case.

2.10. Protests against honour killing

Honour killing is regarded as a 'traditional necessity' (*töre gereği*), a 'good deed' (*sevap işi*) and 'the cleaning up of filth' (*pisliğin temizlenmesi*). There is little public criticism of honour killing in Turkish society. Protests do sometimes occur however, as in the 'Euphrates' case study, where the men who attempted to kill Gönül Aslan were released on the day of the verdict. The defendants, Sakıp (Gönül's husband), and Mahmut, Abdullah and Hacı (Gönül's father's brothers), were sentenced by the Turkish court to 16 years imprisonment. The remaining accused, Gönül's father, Ali, and his brother, Osman, were acquitted. The sentence for Sakıp, Mahmut, Hacı and Abdullah was subsequently reduced to 4 years, 5 months and 20 days because of 'extreme provocation' (*ağır tahrik*) and 'good behaviour in court' (*mahkemedeki iyi halleri*). These appear to be sentence reductions under sections 51 and 59 of the Turkish Criminal Code. However, Sakıp, Mahmut and Abdullah were released as soon as the verdict was announced on 1 December 1998. The attempted honour killing had taken place in March of that same year, and they were still far short of having served out their sentence while on remand.⁷⁸ Women's organisations in Turkey reacted angrily to their release. "We are not surprised at this decision," said Nevin Cerav, writing for the feminist monthly magazine *Pazartesi* ('Monday'), "but we will never get used to it."⁷⁹

This was not the first time that women's organisations in Turkey had demonstrated their abhorrence to honour killing. In the 'Knifing in the square' case study, in which a 14-year-old boy murdered Sevda, his 16-year-old cousin, a female reporter from the *Hürriyet* reported extensively on the killing. Members of Turkish women's organisations then travelled to Urfa to attend the hearing. When they were not admitted (it was not a public hearing as the accused was a minor), the group went to the market square and laid carnations on the spot where the girl had been killed.⁸⁰ Their protest did not simply target the honour killing itself, but also the inhabitants of Urfa who had tacitly condoned it. Nobody on the market square came forward to testify; nobody in the entire city had protested. As a result of the wide publicity that the case attracted, newspapers began labelling Urfa, whose full name is Şanlıurfa (Urfa of renown), as *Kanlıurfa* (Urfa of blood).⁸¹

The sections of the law that make provisions for reduced sentences for honour killing have also come under criticism. According

to lawyer Kenan Hamsioğlu, section 462, which in some cases reduces the sentence to one eighth of the usual prison term, all but incites people to kill. He believes the section should be abolished; as it stands, honour killing is virtually presented as a universal right. The Turkish criminologist, Dönmezer, shares the view that section 462 'almost regards killing as pardonable.'⁸² Şahin writes: 'the intention of the law is to forbid killing, but in its present form the law has the potential to incite a killing.' He too believes the section should be scrapped.⁸³

In 1993, Gaye Dinçel vented her outrage about section 453 in *Çıracık*, a student newspaper. She objected to the light sentence passed on those who commit infanticide, claiming that the law is in effect saying: 'Kill your illegitimate child as soon as possible to both save your *namus* and ensure a light sentence.' She concluded by saying: "This is proof that the family's *namus* is more important than the right to life," and called on women to show solidarity with one another and to effect a change in the law.

It is rare in Turkey for journalists to write critically about honour killing. However, one attack has come from reporter Zeynep Atikkan concerning the 'Knifing in the square' incident. She claimed that Turkey had yet to enter the modern world. She linked honour killing to poverty and to a lack of prospects for improving social status. As a result, people cling to their traditions, and *namus* retains its prime importance.⁸⁴ Further criticism of honour killing has been levelled by journalist, Oral Çalışlar, following the multiple honour killing in Esenler, Istanbul.⁸⁵ "It is customary for us to kill for reasons of *namus*," said the killer's mother in defence of her son. As a rule, the newspaper would have left it at that, but Çalışlar went on to write:

'The more backward a country, the more savage and inhumane the murders committed in the name of sacred values [...]. The murder in Esenler is important because it shows that the culture of violence in Turkey has reached desperation point. What we need to stop and think about here is the notion of 'namus'. Two women left their husbands and went to live with their lovers. I'm sure they knew how dangerous this could be. Given that they took the risk of being killed, they must either have loved those men very much or they saw no other way of escaping from their husbands. What kind of *namus* is it that makes you kill your wife because she doesn't want you? The saddest thing of all is that the *Yeni Yüzyıl*, a supposedly liberal newspaper, holds the women responsible for the murder. Their caption under the photo of the murdered Nuran read: "Nuran, the wife of

Abdullah Aydın, is the cause of this terrible slaughter.” The concept of honour is linked to a country’s level of development [...]. Have you ever considered how close we as a society, with our code of honour, are to those men in Esenler who seized their weapons and ran amok?’

Çalışlar believes that the norms and values of most Turkish men are not so very different from those of the killers at Esenler. Interesting too is his query as to why newspapers devote so much space to honour killings: ‘Why do we always read about yet another honour killing victim, and why do we hear no more – not even the briefest of reports – about the casualties in the guerrilla war against the PKK in southeastern Turkey?’

The answer is obvious: the newspapers are subject to censorship, albeit largely self-imposed.⁸⁶ Honour killing does not constitute a threat to the Turkish state, whereas the PKK does, and the state would prefer to see no reporting on the Kurdish struggle. Çalışlar also wonders why sexual chastity applies only to women and not to men: ‘We have to accept that our notion of honour has some peculiar aspects to it. It is a concept that applies only to men: only a man has namus.⁸⁷ His wife’s namus is located between her thighs. This is clearly a primitive notion [...]. Were the men who claimed ownership of the body and brains of these female bodies correct? Could they demand rights to the bodies because they had once put their signatures to an official piece of paper? If you answer yes to these questions, are you aware that at some primitive level you sympathise with the murder?’

Çalışlar believes that entering into a marriage contract does not give a man life-long rights to a woman. There would not be many Turkish men who subscribe to this view, as Çalışlar is fully aware, hence his final rhetorical question.

One Turkish journalist who has given critical attention to honour killing is Mehmet Faraç. His book, which describes in detail five honour killings of girls and young women in the province of Urfa in the period 1994 to 1998, received considerable attention from the Turkish media. This led to a forum on honour killing and blood feud, held in Ankara in September 1999 and organised by the General Directorate for the Status and Problems of Women (*T.C. Başbakanlık Kadının Statüsü ve Sorunları Genel Müdürlüğü*). A report on the forum can be found in *Töre cinayetleri. Panel bildirileri*, which was published in December 1999. One of the speakers was Şenal Sarıhan, a lawyer who spoke about a group of women lawyers in Ankara who

had been attending rape and honour-killing trials free of charge since the 1980s and who were trying to teach the honour killers and their families other values. She admitted that it was an extremely difficult task. In the 1990s, these women set up the Modern Lawyers Association (*Çağdaş Hukukçular Derneği*) and the Women's Committee of the Ankara Order of Lawyers (*Ankara Barosu Kadın Komisyonu*). They extended their sphere of activity beyond Ankara and attended honour killing trials in Urfa, Diyarbakır, Kars and Kırşehir. According to Şahin, this had a positive effect on judges, especially in courts outside Ankara. She writes: 'In honour-killing trials, the judge is often greatly influenced by the same customs [as the honour killers]. Thanks to our presence and the articulation of our views, the judge comes to share our ideas about human rights and to realise that the right to life is a fundamental right of every individual.'⁸⁸ Since then, the umbrella organisation for women's committees of the Turkish Order of Lawyers (*Türkiye Baroları Kadın Komisyonları Birliği – TUBAKOM*) has pushed honour killing to the top of its agenda.⁸⁹

The sections of the law relating to sentence reduction for honour killings also came under fire at the 1999 forum. Şahin urged that section 453 be scrapped in its entirety, together with section 472 on induced miscarriage. Sarıhan felt that the Turkish parliament should repeal Sections 453 and 462. In the discussion that followed, however, it emerged that the problem did not lie with these sections alone: the concept of *tahrik* (provocation) in section 51, invoked in most honour-killing cases, needed redefining as well.⁹⁰

Vildan Yirmibeşoğlu, a lawyer from Istanbul, has other criticisms with regard to honour killings.⁹¹ She believes that girls who are the subject of gossip and who seek refuge with the authorities are not adequately protected. She cites two examples. In the 'Tractor' case study, the police officer returned the girl to her family after accepting bribes. In the 'Knifing in the square' case study, the girl was not permitted to stay in the children's home because her parents demanded her back. Şehabettin Harput, the Governor of Urfa where this incident occurred, made a similar comment. In an interview with Mehmet Faraç, he stated: "A place must be found where girls who have run away from home can stay until things have settled down on the home front. Whether a girl has run away or has eloped, at some point she either goes to or is arrested by the police, who then give her back to her parents. The police are obliged to return girls up to the age of eighteen to their families. But if we look at what happens in

this area [Urfa], we need a place where we can protect a girl until peace is made with her family [...]. We may be able to prevent honour killings in this way.”⁹²

In the ‘Tractor’ case study, the villagers themselves protested about the honour killers. Not – it must be said – at the time of the killing, as they were too afraid to come forward. But when it looked as though the killers would go unpunished (the killing was accepted as an accident), the villagers took action. They wrote letters to the authorities disclosing what had happened.⁹³

In the Dursun case study, which involved an honour killing in the Netherlands, there was also criticism of the killing. Zeynep’s blood relatives blamed her husband Kemal for Zeynep’s adultery. Serpil, spokeswoman for the family, said over the phone to Gökhan Dursun: “Your brother should have prevented Zeynep from behaving like a whore.” And in a telephone conversation with Kemal, she questioned how Zeynep, who married at the age of fifteen, could have behaved correctly for sixteen years of marriage. Her implication was that Zeynep could not have become ‘bad’ all of a sudden. She had entered the marriage a virgin and had learned no bad habits at home. Kemal, who understood that this was an accusation levelled against him, defended himself by saying that he had been a husband to her. But Serpil continued: “If the wife plays the whore, the husband is to blame.” Kemal became very angry and started swearing. Serpil said: “You yourself have slept with other women. Is my sister not a woman too?” In other words: does my sister not have sexual needs just as you do? Kemal replied that that was no reason for his wife to play the whore. As a man, he was entitled to have girlfriends, but his wife had no right to take a lover.

Serpil also complained to Leyla, the wife of Gökhan Dursun: “He murdered her and tossed her aside. He should have been a real man earlier on and made sure that his wife didn’t become a whore. It is the man’s fault if his wife becomes a whore!” Leyla replied: “He says that he gave her all she needed.” Serpil says: “It’s the man’s fault, it’s the man’s fault! He should have stayed at home and been a husband to his wife and a father to his daughters.” Serpil is critical of the fact that Kemal was never at home. He collected an invalid’s benefit, but spent his days and evenings at the coffeehouse. On weekends, he went to his Dutch girlfriend’s and spent the night there. He scarcely saw his wife. This line of reasoning from Zeynep’s blood relatives is not uncommon in the Islamic world, or in Christian Spain.⁹⁴ Unless a woman is regularly satisfied in bed, the argument goes, she will

seek out another man.⁹⁵ It was not only Zeynep's blood relatives who objected to the honour killing. So too it seems did the Turkish community in the town where the Dursuns lived. The probation officer noted: 'Unusually for an honour killing, the sympathy of many Turks in this case goes out much more to the victim, Zeynep Dursun, than to the accused, the Dursun brothers. In the Tekin case, ⁹⁶ the courtroom was packed with Turks who came to give Tekin moral support. In the case of Mehmet Dursun, there were few Turks in the courtroom, which suggests that he did not have the support of the Turkish community.

3. The honour killer

3.1. Honour killing as a ritual

THE AYANOĞLU CASE STUDY: 'LOVE IN THE FACTORY' (1992)

Yaşar Ayanoğlu, 28 years of age and unemployed, is an inveterate gambler and is up to his ears in debt. He and his wife, Aysel, decide to send their two eldest children to their grandparents in Turkey for the summer. The plan is for Aysel to get a job in a factory so that she can help pay off the debt.¹ Their youngest child, a two-year-old girl, will spend the summer with Yaşar Ayanoğlu's brother, who lives in the same town. Aysel ends up working alongside Nuri Sakal, a single man living illegally in the Netherlands. Nuri and Aysel find it easy to talk to one another and a relationship begins. The other workers on the factory floor, most of whom are Turkish, are aware that something is going on and they warn Nuri and Aysel. Aysel realises that it is getting too dangerous: there is too great a risk that her husband will find out about the relationship, so she stops work. The youngest child comes back home to live with them (the eldest two are still in Turkey). Nuri Sakal cannot resign himself to the fact that the relationship is over. He waits for Aysel at the entrance to the swimming pool, where she goes with her girlfriends every Wednesday evening. He talks her round and persuades her to leave her husband. Aysel goes to live in a women's refuge and sees Nuri Sakal regularly.

Yaşar Ayanoğlu discovers the telephone number of the refuge and phones her. He asks her to come back to the house so they can arrange a divorce. This turns out to be a pretext to lure her home. He threatens to kill himself if she dares leave him. Putting the pistol to his temple, he says: "If you leave me, I'll kill myself." Aysel promises to stay home. After a while, however, she cannot bear it any longer and she goes back to the women's refuge, this time taking her youngest child with her. Yaşar Ayanoğlu is so enraged by this that he tells Aysel's girlfriends that he'll shoot two of Aysel's brothers if she doesn't return the child to him. Aysel is frightened and has their daughter brought back to him. Yaşar takes the child to Turkey and leaves her with his parents.

Back in the Netherlands, Yaşar cannot reconcile himself to the fact that his wife has left him and has a boyfriend. He keeps watch near the women's refuge, and sees his wife walking arm-in-arm with a strange man – Nuri Sakal. Yaşar Ayanoglu pulls his wife away from Sakal. He beats her, breaking her nose, and takes her home. He says he'll behave as if nothing has happened between them, provided she lures Nuri to an appointed place so that he can kill him. "Then the honour of our marriage will not be affected and we can go on as before," he tells her. But his wife doesn't want to cooperate. She enlists the help of her brother to mediate. He explains to Yaşar that things cannot go on like this and that it would be best for them to divorce. Yaşar finally agrees to a divorce, provided Aysel makes no claim on the children.

Aysel returns to the refuge. She has regular assignations with Nuri in various hotels. He tells her that he has been looking for Yaşar Ayanoglu to kill him for breaking her nose. From her girlfriends, Aysel hears that Yaşar is inclined to give her the children but only on condition that she does not remarry and stops seeing Nuri. Aysel warns her boyfriend to give up the job at the factory since Yaşar might go and look for him there. After all, Yaşar knows him by sight and knows where he works. But Nuri is not afraid and continues working. One Monday morning, Yaşar enters the factory with a pistol and two cartridge clips, each containing ten cartridges. He shoots Nuri from close range – a distance of one to two metres. After two shots, Nuri is lying on the floor. Yaşar empties the cartridge. He then reloads his gun with the second cartridge, aims again and quickly empties the second cartridge. He waits at the scene of the crime until the police arrive. Yaşar is sentenced by the courts to 8 years in prison for murder. There is no appeal.

Honour killing is a cleansing or purification ritual involving the elimination of pollution in a formalised, dramatic way.² Honour killing is not only about eliminating someone, but also about the way in which this is done. The ritual should clearly demonstrate the kind of person the victim was.³ Ideally, an honour killing meets the following criteria.

Firstly, the killing occurs in a public place, in daylight, and with many bystanders.⁴ Because *namus* is a public matter, the purification should take place in public. The traditional place is the market square, as in the 'Stabbing in the square' case reported in the *Hürriyet*. A further example is the Ayanoglu case study, in which the killing took place on the factory floor, amidst all the employees. Interestingly, Ayanoglu's defence counsel saw this as proof of manslaughter. According to the lawyer, the honour killing occurred in a

sudden outburst because ‘the offence was committed in broad daylight, the location was unknown to my client, and there were a considerable number of people present.’ The lawyer concluded that if it were premeditated murder, there would have been plenty of opportunity to devise and execute a plan involving far less risk. For Ayanoğlu, however, the location was ideal: it was where his wife met Nuri Sakal and where his *namus* was tarnished. Moreover, it allowed Ayanoğlu to cleanse his *namus* in the presence of the Turkish compatriots who knew about his wife’s extramarital affair.

Secondly, the killing usually involves many shots or knife thrusts.⁵ In addition, the victim is shot at close range or, once the victim is on the ground, the killer continues to shoot from close range. In many honour killings, the killer stands face to face with the victim, wanting to be seen by the victim. Sometimes the victim is told in no uncertain words the reasons for the killing, as in the Ayanoğlu case study. Standing about a metre away, the killer emptied a cartridge clip containing ten bullets into the victim, looking his victim straight in the eye as he did so. As he fired, he said loudly in Turkish: “My whole life has been destroyed by you and my children are gone, and you took my wife off me, so *there* and *there* and *there*.” With each ‘there’, he fired a shot. When the victim was lying motionless on the ground, Ayanoğlu fired a second series of bullets.

Thirdly, the perpetrator acts coolly and calmly. He is not supposed to display any emotion. Ayanoğlu’s court records contain no specific statements but there are witnesses who say that Ayanoğlu was very calm after the shooting.

Fourthly, the victim must die: injury will not suffice.⁶ One example is the Gürsel case study, in which Gürsel shot his sister several times. When she fell to the ground, he shot her a few more times. When a nurse wanted to intervene, he prevented this, saying “She has to die.” According to witnesses, Gürsel felt the victim’s pulse to confirm that she was dead. In the Uzun case study, to explain why he had fired all eight bullets from his gun, the killer admitted: “I wanted to be sure that he was dead.” The fact that so many shots are fired once the victim is already lying on the ground is further evidence that the victim really must die, as in the Ayanoğlu case.

Fifthly, the honour killer must be certain of the facts before acting. An honour killing should be carried out on the basis of proof, not gossip. In the Dursun case study, the two brothers did not decide on an honour killing until they had the cassette tape in their possession. The victim was also subjected to a final questioning to make sure that

the killing was justified, as happened in the Dursun case. Mehmet invited Zeynep to his house to question her about her relationship with Ali Eralp. If the discussion reveals that the potential victim is dishonourable, the perpetrator has the confirmation he requires to justify the killing. After his last conversation with Zeynep, Mehmet Dursun said: "Now I can kill her."⁷

Sixthly, the killer gives himself up immediately to the police, with the words *namusumu temizledim* (I have purified my honour), or he waits at the scene of the crime for the police to arrive. In this way, he demonstrates to his community that it was an honour killing and that he has nothing to be ashamed about. He is showing that his honour is cleansed. Thus in the Akkaya case study, Akkaya said: "I wanted to give myself up to the police because I committed the crime to save my honour and not because I'm a cowardly murderer." In the Ayanoglu case study, the killer stayed in the factory and waited till the police came to collect him. A Portuguese worker said: "After the shooting, the man put his weapon back in his jacket pocket and stood there calmly. I then saw him starting to walk around a little. He seemed to be waiting calmly for the police to arrive."

Seventhly, the killer says that he is not sorry for what he has done. We almost always encounter this in articles in the *Hürriyet* on honour killings.⁸ It emerges as one of the key components of an honour killing. A display of remorse has no part in honour purification. There are two ways in which honour killers display a lack of remorse. Some show neither remorse for the killing nor sorrow that it had to happen, while others show no remorse about the killing but are sorry that it had to come to such a pass. The Dursun brothers belong to the first group. Kemal's joy at the death of his wife was remarkable. He said to his father over the phone: "I kept hearing voices. I couldn't rest until this business was over. My mind is at rest, Father. Shall I tell you the truth? I feel reborn." However, Kemal had to convince his father of the need for the honour killing, and may therefore have been exaggerating. The Akkaya case study is an example of the second type. The probation officer explained it succinctly: "The man in question seems very sad that he had to kill his wife because she had robbed him of his honour. He loved her and that is the reason for his sorrow, not the crime itself."

Eighthly, an honour killing may have a symbolic aspect. The number of knife thrusts could be a multiple of seven,⁹ or the victim may be placed in a certain position, (e.g. a woman with her legs apart and her thighs uncovered).¹⁰ I encountered one such honour killing

in my research. In the Dağ case study, three cartridges were placed on the victim's body, probably a reference to the victim's three closest male relatives (his father and two brothers), as a warning not to avenge the killing. There was also one case of symbolic disfiguring. Akkaya cut off his victim's penis after he had killed him, to punish him for committing adultery with Akkaya's wife. Akkaya told the probation officer that he had actually wanted to do it before the murder and to put the penis in the victim's mouth with the words: 'This is what you ruined my life with and what I'm now ruining yours with.' But in practice, it would have been difficult. Shooting someone in the face can also be a form of symbolic disfigurement. Dishonourable women are said to have a black face (*yüzü kara*), and perhaps that is why some victims are deliberately shot in the face. However, this happened only to the female victim in the Dursun case study.¹¹

The above summary shows that an honour killing is not simply the killing of an undesirable person, but a ritual aimed at removing a stain from one's *namus*. The grandfather in the 'Stabbing in the square' case study who referred to the honour killing of his granddaughter as 'cleaning up the filth' (*pisliğin temizlenmisi*) did not do so lightly. After the deed, the honour killer, Utlu, spoke of filth that had been cleaned up. His friends knew at once what he meant. Mary Douglas explains that, when we as anthropologists want to examine ideas about dirt, we should not think in terms of hygiene or pathology, but should regard dirt rather as something that does not belong: 'We are left with the old definition of dirt as matter out of place.'¹² A girl who is the subject of scandal is seen as dirty: through her conduct, she has made life impossible for herself in the community, and she has brought shame upon her family. By cleaning up the dirt, the family is clean once more; they can hold their heads up again and participate in the life of the community. There may be a ritual dimension to the way in which they demonstrate this to the community following an honour killing. In Bekir Yıldız's story, *Reşo Ağa*, the female members of the honour killer's family go to the bathhouse after the honour killing and put henna in their hair (*namusları ak-pak oldu diye*, 'because their *namus* is purified'). I do not know whether this is normal practice following an honour killing.¹³ In Jordan, there is another custom to show that the family's *namus* has been cleaned: a white ribbon is stretched along the four edges of the flat roof of the house and a fire is lit on the roof.¹⁴ In the 'Tractor' case study, the killers fired their guns into the air as they would at a wedding.¹⁵

The above summary of honour-killing characteristics should not of course imply that all such killings assume this classic form. They simply describe the model honour killing. There are in fact few killings that meet all criteria. It would be incorrect to define a crime as an honour killing only if it satisfied all – or most – criteria. In my research, there were only three instances in which the honour killers went directly to the police (Akkaya, Köksal, and Utlu),¹⁶ and four in which they remained at the scene of the crime (Ayanoglu, Ercan, Gürsel and Yiğit). The remaining killers ran away, but either their escape was so clumsy or there were so many witnesses that we might argue that it was never their intention to get away (Altun, Barut, Biber, Çetin, Şengül, Tekin, and Türkmen). In the Çetin case study, the killer successfully avoided arrest for one and a half year's after the killing. He himself was extremely surprised to have escaped capture for so long. The most professional escapes are to be found in the Dursun and Dağ case studies, where the killers were hired assassins.

Nor do the honour killers always express no remorse.¹⁷ This may be because they believe that the Dutch justice system will consider them even more callous if they say they are not sorry for what they did.¹⁸ In Turkey, there would be no need to express regret because everyone knows this is part of the purification ritual.

3.2. Planning: accomplices

One aspect of honour killing that I have not yet touched upon is planning, which Kressel sees as an inherent feature of honour killings.¹⁹ This is not surprising if we bear in mind that honour killing is a ritual: a ritual is not the product of a sudden outburst but is prepared in advance. In their explanation of ritual, Moore and Myerhoff also list planning as one of the characteristics.²⁰

In planned honour killings, a 'family council' (*aile meclisi*) may be held in advance. There, the decision is taken as to who will carry out the deed. Although committing an honour killing is a prestigious matter, all considerations need to be weighed carefully so that the objective is achieved with minimum damage. In other words, it is vital for the family breadwinner to stay out of prison. Ideally, an under-age son is selected to carry out the killing: he will be given a shorter sentence than someone who is no longer a minor.²¹ The family council agrees that the perpetrator will shoulder all the blame so that other family members do not risk a prison sentence through

their role as accomplices. As accomplices are rarely tried, this strategy appears to be effective.

Because the honour killer tells the police that he acted alone, all those involved deny the existence of the family council. This makes it difficult to form a clear picture of the council and the family members that were present. In the Dursun case study, we see that, if a married woman is the subject of scandal, the husband and his brothers consult with one another. According to the victim's family, there were also consultations with Yılmaz Dursun, the father of the Dursun brothers, in Turkey. The telephone tap reveals, however, that he was not at all in favour of such a hasty killing. This is understandable considering that, by virtue of living in Turkey, he had the most to fear from blood revenge. However, from the ready assumption that the father knows what is going on, we can assume that his involvement is the normal pattern. The father and brothers of the married woman may also be present at the council (the Türkmen case study). In the 'Euphrates' case, which involved a dishonourable daughter, the father consulted with his brothers.

Although honour killings are in principle planned, not all adhere to this rule. One such example is the above-mentioned Utlu case study. Another is the 'Hanging around the flat' case study, in which Koparan was suddenly faced with a threatening situation. The classical example of an unplanned honour killing involves a man who catches his wife with her lover and decides to kill one or both of them on the spot. I encountered no such example in my research and I question whether this type of honour killing is as unplanned as it appears. The husband often already suspects something and may lie in wait to entrap the couple. Another classic example is a killing following a sexual insult. Here, *namus* is so seriously compromised that the person insulted feels obliged to purify his honour (see the Ercan case study, p. 142).

It is common for the perpetrator and his defence counsel to subsequently present the honour killing as unplanned. In the Yiğit case study, the killer drank heavily the evening before the killing. The lawyer did his best to demonstrate that this drinking was 'culturally determined', in other words, that his client was drinking with other wedding guests. Otherwise, the drinking may have looked like 'Dutch courage', suggesting that the killing was planned. In the Ayanoğlu case study, on the other hand, the perpetrator was keen to suggest that alcohol played a role, probably to present the killing as

manslaughter rather than murder. Ayanoglu claimed that he drank heavily before the killing and could therefore no longer remember what he had done. A blood test revealed, however, that he had not touched a drop.

In the Tekin case study, the honour killer presented the killing as the unplanned result of an emotional outburst. According to a police officer closely involved with the case, Tekin's claim that he had not planned the killing was prompted solely by his desire to qualify for a reduced sentence. We have no way of finding out whether this was in fact the case but, given the maximum prison sentence in the Netherlands of twenty years for murder and fifteen years for manslaughter, it does appear plausible that perpetrators – whether of their own accord or on the advice of their lawyers – try to convince the court that the honour killing was unplanned.

If an honour killing is carried out by the man who bears prime responsibility for a woman (her father in the case of an unmarried woman; her husband in the case of a married woman), it is difficult to establish whether the killing was planned. If the father is the perpetrator and he has a son aged 14 to 18, the lawyer could argue that the killing was not planned, for otherwise the under-age son would have done it. This argument could apply in the Yiğit case study, where – right up to the Court of Appeal – the discussion hinged on whether it was murder or manslaughter. However, this argument was not put forward by the defence. In the Tekin, Ayanoglu and Yiğit case studies, the man with prime responsibility for the woman did not leave the honour killing to someone else. The police officer who had close contact with Tekin said of him: “He would not have wanted to leave it to someone else.” The same may also be true of Yiğit, or perhaps he did not dare leave it to his sixteen-year-old son, as the intended victim had on several past occasions been violent. Ayanoglu probably had no one else to commit the killing; he certainly had no son of a suitable age.

If, as in the case below, the under-age son carries out the honour killing, the father quickly falls under suspicion.

THE BIBER CASE STUDY: ‘MATRICIDE’ (1988)

In 1971, Biber comes to the Netherlands as a guest worker. In 1973, he has his wife and his son Mevlüt, then one year old, brought to the Netherlands. Three more children are born – a son, Şefik, and two daughters. Biber co-

mes from Malatya in eastern Turkey. His wife comes from Istanbul and, in the eyes of Biber, she conducts herself too freely. She refuses to wear a headscarf and talks to men outside the family. The family moves house three times in two years, partly because they need larger houses as more children are born, but also because Mrs. Biber's western behaviour shames her husband in the presence of his neighbours. The problems between the couple escalate. In 1982, it becomes too much for Mrs. Biber. She is admitted to a psychiatric hospital and is diagnosed as having hysteria.

In 1983, Biber orders his wife and the children to Malatya, his birthplace, because he wants his children to attend school there. Mevlüt, the eldest son, is then 11 years old. His father places a heavy responsibility on his shoulders by asking him to keep an eye on his mother. With her urban background, Mrs. Biber finds life in Malatya intolerable. She feels as though she is being watched and is very unhappy. Biber receives reports from Turkey that his wife is not conducting herself properly. His family tells scandalous tales about her and Biber feels obliged to bring his wife and children back to the Netherlands after six months in Turkey. The following summer, however, he sends his two sons back to Malatya. His family does not want to shoulder the responsibility for their upbringing, but Biber is able to persuade one of his wife's brothers to look after them. The brother moves from Istanbul to Malatya, where Biber buys a shop for him. Biber also sends regular payments (500 guilders a month, he claims) to support the family.

A year later, when the brother-in-law absconds with the money and all the assets, Biber is obliged to bring his sons back to the Netherlands. He blames his wife for the fiasco in Turkey and it degenerates into such a fight that Mrs. Biber leaves and goes to a women's refuge. She is soon home again. Two months later, she tries to commit suicide and is admitted to a psychiatric hospital for five months (the diagnosis is manic depression). In the meantime Biber, who is now unemployed, looks after the children. To Mr. W. from the Regional Institute for Mental Welfare [RIAGG], who pays regular house calls, he says that he is ashamed of his wife's behaviour: "Everyone calls her a whore. That's why we as a family have been driven out of the Turkish community." When Mrs. Biber comes out of hospital, she does her best to please her husband. She is even prepared to wear a headscarf. But the issue of returning to Malatya remains a sticking point. Biber talks about it constantly and Mrs. Biber absolutely refuses to go. In the summer of 1986, the family goes on holiday to Malatya where the fourteen-year-old Mevlüt becomes engaged to a sixteen-year-old girl. In January 1987, Mrs. Biber flees with the children to a women's refuge and files for a divorce (Mevlüt ends up in a reception centre because he is too old for the women's refuge). Biber pleads with his sons to come back and live with him,

which they do as they have had an argument with their mother. In spring 1987, Mrs. Biber accuses her son Mevlüt of committing incest with his sister. This accusation makes Mevlüt so furious that, together with his brother, he decides to visit his mother with the intention of killing her. On the way, however, he is injured in a car accident.

In summer 1987, Biber goes on holiday to Turkey with his four children. They learn that Mevlüt's engagement has been broken off. It seems that Mrs. Biber wrote a letter to the girl's family about the alleged incest. Mevlüt is furious. At the end of the holiday, Biber returns to the Netherlands with only his sons, leaving both daughters behind with his family in Turkey. Mrs Biber is not happy about this and she enlists the support of a lawyer who asks the juvenile court to intervene in the abduction.

In autumn 1987, Mevlüt and Şefik ask the magistrate of the juvenile court if they can go back to live with their mother. Mr. B., the family guardian, believes that the request is prompted by Biber, who has found work again and can no longer take day-to-day care of the boys. According to Mr. B., Biber also wants Mevlüt to keep an eye on his mother, and so Mr. B. does not support the request. However, the magistrate decides to honour the children's request. What Mr. B. feared, happened. From the moment that Mevlüt goes to live with his mother, he sets himself up as her protector and controller. According to Mevlüt, his mother wants to 'go out' every evening, by which he means 'visiting a female friend'. He makes it clear that she can only do this once or twice a week. Before a month is out, Mrs. Biber no longer wants Mevlüt in the house. As there is no room in a reception centre, Mevlüt goes back to live with his father. His fourteen-year-old brother, Şefik, continues to live with his mother. In the meantime, the Biber's divorce has become official.

The magistrate threatens to imprison Biber if he does not divulge the whereabouts of his daughters in Turkey. By the time Biber is arrested early one morning, a drama has already taken place the evening before at Mrs. Biber's house. Mevlüt had broken into his mother's flat and hidden in her bedroom. When she and her son, Şefik, came home late from visiting Aunt Güzin (a friend of hers) and she entered her bedroom, Mevlüt attacked her with a knife. In the ensuing struggle, Mrs. Biber managed to wrest the knife from her son. Mevlüt asked his brother to fetch another knife from the kitchen. Şefik brought him the smallest knife he could find (a paring knife), which was of no use to Mevlüt. He eventually killed his mother by strangling her. He told his brother to go back to Aunt Güzin's and not to say anything to anyone. The next day at school, when unable to produce his homework at the teacher's request, Şefik could keep silent no longer. He tells what has happened.

When the police arrested Mevlüt, he confessed immediately. He said that he had asked İlhami, a good friend of his father's, to take him to his mother's house on the pretext of picking up his passport, which he had left there. There was nobody home when he got there. İlhami lent him a screwdriver to get in. İlhami gave him money to take a train back, and then drove off. Mevlüt said that İlhami did not know the real reason for going to his mother's flat, but İlhami clearly did know. If Mevlüt had only come for his passport, why did İlhami not wait and take him back again? The police, who were also of this view, continued to question him. Mevlüt then admitted that İlhami had in fact waited for him and driven him back. The fact that Mevlüt did not mention this initially is very telling: it suggests that he was trying to shield İlhami from suspicion of being an accessory to the crime.

Biber also played a key role. His son Şefik told the police that when he was at Aunt Güzin's place, he went back home briefly to pick up a toy car for Aunt Güzin's little boy. He saw his father, Mevlüt and another man standing by their flat but they did not see him. Frightened, he ran straight back to Aunt Güzin's house and told his mother to call the police. Mrs Biber was also very frightened and said she did not dare go home. Later, however, she plucked up the courage, saying that a psychological counsellor had told her not to be frightened. They went home late that evening. Şefik's statement to the police thus reveals that Biber was also present. Even if Şefik's statement were a fabrication after the event, Mevlüt's statements contain enough information for us to deduce that Biber knew about the killing: 'When I went to my mother's house [...], my father knew that I went to kill my mother and her boyfriend [...].' By 'boyfriend' he means Mustafa, the husband of Aunt Güzin (the woman friend whom his mother often visited). Mevlüt had concealed himself in the bedroom with the intention of killing them both.

There are two points here that are difficult to comprehend: firstly, that Mustafa was Mrs Biber's boyfriend, and secondly, that a boy armed only with a knife could hope to kill two adults. Mevlüt had enough difficulties with just his mother. Did he really think he could tackle two people? Or was that never in fact his intention and was the talk of his mother's boyfriend a later fabrication to lend credibility to the honour killing?²² Mevlüt made further incriminating statements about the role played by his father: 'In no way did my father try to stop me when he knew that I was going to kill my mother and Mustafa'; 'I said to my father: "I'm going to destroy them. By that I meant kill them. [...]."' Without saying a word, my father turned away and

started washing the dishes. So he knew exactly what I was going to do'; 'My father and I arranged that I would give him a call when "it" had happened. By that I meant that I'd call him if I'd killed one or both of them'; 'My father didn't actually order me to do it. According to our religion, [...] one of us must do it. So indirectly, it was an order from my father [...]. Although my father didn't say in so many words that I should do it, in his own way he gave me permission to do it.'

This equivocation on Mevlüt's part about who ordered the killing is his way of saying: My father gave the order, but I take full responsibility upon myself so that he will not be punished. Once outside the interview room, Mevlüt became even more communicative. Four days after the murder, a detective recorded a conversation he had with Mevlüt while taking him back to his cell: 'The suspect declared that the eldest son has to act to save the family's honour if there are problems between a husband and his ex-wife. He said that his father couldn't do so because he had to look after the other children. He said that his father knew what might happen [...]. He says his father told him that he had to kill his mother and that man to save their honour, otherwise he wouldn't be a man.'

When confronted with his son's statement, Biber's response was: "It is absolutely incorrect that I put pressure on my son. Mevlüt might be saying so now, but I think that he's doing it to try and get out of being punished. Mevlüt is lying." During questioning, the father revealed by way of a hypothetical example what he thought about honour killing: 'If you ask me what is customary in Turkey when a husband catches his wife in bed with another man, of course I can't speak for everyone else. If I were in that situation and if I didn't have two daughters to look after, I would shoot the wife. The fact that my two daughters would have no one to look after them if I were in prison would stop me from killing in a case of adultery.' When reading the charge, Biber did not want this statement included. He said: "I can't sign this. I was angry and said things I didn't mean. If I caught my wife committing adultery, I would call the police to get evidence for a divorce."

After the honour killing, İlhami and Biber helped Mevlüt in all manner of ways: İlhami took him to his house where his wife tended to his facial injuries, he buried the screwdriver and Mevlüt's blood-stained clothes, and Biber brought him fresh clothes.

There was insufficient evidence to convict İlhami and Biber. Mevlüt was sentenced to six months in borstal.

In the other case studies involving children (Şengül, Elmas, and Uzun), the father of the under-age honour killer also came under immediate suspicion. Only in the Uzun case was the court able to convict the father as the accomplice of his son, the perpetrator. However, this case is unsatisfactory in that the father was in turn pressured by others, Fakir and Özkök, to commit an honour killing. These two men were convicted by the courts but acquitted upon appeal because Uzun and his son retracted their incriminations, almost certainly for fear of reprisals.

If honour killers are still minors, police suspect the presence of an accomplice. But if they are adults, the police often give insufficient consideration to this possibility, as shown in the Çetin case study.

THE ÇETIN CASE STUDY: 'AT SUMMER CAMP' (CONTINUED)

In the Çetin case, the honour killing was carried out by Fatih Çetin, the 21-year-old brother of a woman who committed adultery. He fled after the killing and was not arrested until eighteen months later. Fatih Çetin claimed that he had acted on his own initiative. His version of the story is as follows:

Fatih Çetin is recently married and lives with his wife in his parents' house. His sister and her husband, Kalemli, visit them every Saturday morning. One Saturday morning while sleeping in, he overhears his sister and brother-in-law talking in the next room. Kalemli is trying to comfort his wife. He tells her that, although she has been raped by Özbay, he wants to continue with her as before. Çetin is completely beside himself when he hears about the rape: his decent, virtuous sister raped! His first thought is 'how terrible for Father!' That afternoon, he visits his brother-in-law. His sister is not at home. They go for a drive and Çetin tells his brother-in-law that he overheard their conversation. Kalemli turns pale and tells him not to get involved, but Çetin is now satisfied that the story is true. Back at Kalemli's house, while his brother-in-law is in the kitchen making tea, Çetin furtively looks up Özbay's number in his sister's address book. That evening Çetin phones Özbay and confronts him with what he knows. Özbay brushes him off with the words: 'Do you realise who you're talking to? This is none of your business.' This rude response is not received at all well by Çetin, who decides to teach the man a lesson. The following day he buys a gun, steals a car, and drives to Özbay's flat, where he lies in wait for him. When Özbay drives up, he shoots and kills him while Özbay is still at the wheel.

This story is presented exactly as an honour killing should be: the killer has acted entirely alone. But was this really the case? Immediately after the murder, Mrs Özbay accused Kalemli of the murder because he and her husband were involved in a flaming row in which Kalemli accused Özbay of raping his wife. But the police had to release Kalemli after four days: he had a good alibi and could not have carried out the killing. However, Kalemli may have been an accomplice. The fact that his wife was ‘raped’ by Özbay is a motive for an honour killing.

‘Coincidence’ plays a key role in Çetin’s statements. By coincidence he overhears the conversation between his sister and her husband, in which he learns all the information he needs (the rape and the name of the rapist). By coincidence, he finds his sister’s address book at her house and immediately takes down the number of the rapist, who is a friend of the family. Of course, we can never rule out coincidence entirely, but here it has a clear function: it ensures that the Kalemli family is not involved in the honour killing. Independently, Çetin learns of the ‘rape’ and, independently, he finds the telephone number of the ‘rapist’.

There are other factors that cast doubt upon the alleged conversation between Kalemli and his wife. According to Çetin, his sister was crying, saying that she had been raped, and Kalemli was comforting her. But presumably, Kalemli knew that she had not been raped (this was evident from the letter and from her association with Özbay, even after the summer camp) and he would therefore not be comforting her.

Initially, Çetin did not mention his drive in the car with Kalemli; he was forced to admit to it after witnesses claimed they had seen them together in a car the day before the murder. Mrs. Kalemli, who was at a friend’s place that afternoon, strenuously denied that her husband and Çetin went for a drive together. What were her reasons for denying it so adamantly? I believe the most logical explanation is that Kalemli informed Çetin of the rape (for this is how he would have presented it) and asked him to purify their *namus*. Because the purpose of the car trip was to show Çetin where Özbay lived, it was too incriminating to be mentioned. Moreover, this version of events is fully in keeping with honour-killing practice: if a husband – for whatever reason – cannot or will not carry out the killing himself, he enlists the support of his brother or his wife’s brother.

It is astonishing that Çetin was at liberty for a further eighteen months. The police had heard the rape story from the victim’s wife as

early as the day of the killing. Not just the husband, but also the male blood relatives of the 'raped' Turkish woman should have been immediate suspects. Çetin was not arrested until a reward of 200,000 guilders was announced for any tips leading to the murderer's arrest. Çetin was reported to the police by an acquaintance to whom he had told everything directly after the killing. He was sentenced to twelve years in prison for murder by the magistrate's court, the high court, and the Court of Appeal.

Not only do the police sometimes fail to consider the possibility of accomplices,²³ even when there are suspicions, the accomplices may not be tried for lack of evidence. In the Dursun case study, the Public Prosecutor's office had their doubts about the husband, Kemal Dursun. Kemal's official version of his role in the honour killing was: 'I deny any involvement. I was unaware that my ex-wife was having a relationship. She could do as she liked as far as I was concerned. Under Turkish law, we weren't divorced but we were planning to get one. I have nothing to do with Turkish law. I don't live according to Turkish codes of behaviour. I don't mind if Zeynep has a relationship with someone else.' However, the telephone taps show him to be fully informed about the honour killing. But there was insufficient evidence for a conviction, and Kemal knew this. The police heard him say in a telephone conversation: 'The police know what's going on, but they can't solve the case because they have no proof.' The public prosecutor hoped that if the killer (a hired assassin) should ever be found, he would provide more information about the role of Kemal Dursun. But when the assassin was picked up two years later, he kept silent and the police had nothing on which to convict Kemal Dursun.

There are four characteristics of an honour killing that point to the involvement of an accomplice. Firstly, if someone other than the man primarily responsible for a woman commits the honour killing; in other words, if the killer is someone other than the father or the husband. Secondly, if the killer emphasises that he acted entirely alone, or words to that effect. Thirdly, if the accomplice arranges for a strong alibi. For example, Kemal Dursun left for Paris shortly before the killing, Elmas went to Turkey and, in the Çetin case, Kalemli made sure that he was in public at the time of the killing. The fourth characteristic is the hiring of a top-flight lawyer. The accomplice will ensure that the killer has a good lawyer in order to secure the lowest possible prison sentence. In my study, this happened in the Dursun, Türkmen and Çetin cases where, in each instance, a brother or

brother-in-law of the husband committed the honour killing. Where children were involved, there was no need for an expensive lawyer because nobody expected a long prison sentence.

3.3. The honour killer has motives of his own

In the Biber case, the son, Mevlüt, was himself strongly motivated to carry out the killing. He told the police: 'In response to the question of what my motives were for killing my mother, I must name three things, namely: the honour of myself and of my family, revenge and the interests of my two little sisters who are still in Turkey.'

Mevlüt very neatly summed up his motives here. I will discuss the third motive in more detail in 5.1. The first (regarding his *namus* and that of his family) is clear: the *namus* of the family was redeemed through the killing of the dishonourable mother. But we are concerned here with the second motive: there was more at stake for Mevlüt than simply purifying *namus*. He had a bone to pick with his mother because of what she did to him – accusing him of incest and making the accusation public, which caused his engagement to be broken off.

In the Dursun case study, the perpetrator, Mehmet Dursun, was even more intent on *namus* purification than his brother, Kemal Dursun, Zeynep's ex-husband. In chapter seven, I examine Mehmet's possible motives in detail. It appears that Kemal Dursun, the accomplice, was not the initiator but was instead swept along in the wake of his brother, Mehmet. It was Mehmet who invited Zeynep's younger sister, Ayşe, to the Netherlands and had her live with Zeynep to keep an eye on her. It was Mehmet who was officially living with Ayşe, to enable her to reside legally in the Netherlands. It would have been possible for her to live with Kemal, who after all was officially divorced. It was Mehmet who, once the relationship between Zeynep and Ali Eralp had leaked out, was intent on getting to the bottom of things. It was probably also Mehmet who approached the hired assassin, who lived in a room above his coffee house. And it was Mehmet who stayed in the Netherlands to coach the assassin.

In the Şengül case study, it was not the eldest son but the second to eldest, Ibrahim, who killed Çağman, the man who compromised his mother's honour. This was not because Ibrahim was a minor, as the eldest son was also under eighteen, but because he had been more badly treated by Çağman. While his father was working in the

Netherlands as a guest worker, his mother had stayed behind in Turkey with the children. She began a relationship with Çağman, a friend of his father's who was supposed to keep an eye on the mother and children. Ibrahim was the son who most turned against Çağman and who was subsequently beaten by him. He was even – temporarily – evicted from the house and forced to sleep in a neighbour's scullery. Thus, Ibrahim probably had two reasons for carrying out the honour killing: his father had ordered him to do so and he had his own bone to pick with Çağman.

3.4. Female honour killers

In reports from the *Hürriyet* on honour killings committed by women, the killing is usually motivated by a desire to prevent loss of *namus* – in other words, the woman kills the man who is about to sexually assault or rape her. In such cases, the newspaper uses the expression *namusunu korudu* (she defended her *namus*), rather than *namusunu temizledi* (she purified her *namus*).²⁴ We could call this 'preventive honour killing'. If a woman's *namus* is in grave danger and there are no male members of her family present, a woman can and must defend her *namus* herself.²⁵ In such a situation, she is expected to take on the male role and to cast aside the passivity normally associated with her womanly role.²⁶ A man may also commit a preventive honour killing, in which case he kills the man who is planning to sexually assault his wife or another female member of his family. This too is referred to as protecting (*namusunu korumak*), rather than purifying *namus*.²⁷

When a woman's *namus* is purified after the event, male members of the family are usually the ones who commit the killing. In his research, Kressel encountered only one instance of a female honour killer and this turned out to be a front. The woman took the blame herself and 'confessed' to the police.²⁸ This also happened in the Köksal case study in order to add credibility to the rape story. It was established beyond doubt that the girl did not commit the killing. Suspicion fell on her father, but there was no proof. In the Uzun case study, a girl was initially going to take the blame for the honour killing. Her brother wore her clothes when he killed her ex-boyfriend so that potential witnesses would give a description fitting his sister. But the girl refused to cooperate after the killing. Another reason for allowing the girl to shoulder the blame is to make murder or man-

slaughter look like an honour killing. In my discussion of honour killing as camouflage, I give the example of Sema Akın, who swore that she had killed her brother-in-law for reasons of honour. It emerged, however, that her husband had killed him for quite different reasons.²⁹

It is generally assumed that no women are present at the family council where the decision to commit an honour killing is taken. According to Kressel, at most, women can be tried as accomplices because they were present at the council and not because they planned the killing. Kressel cites three instances in which mothers lured their daughters to the place where they were to be killed.³⁰ I believe, however, that the mother's role may go beyond simply acting on orders. In the Köksal and Çetin honour killings, women probably played a more active role in the decision to kill the male transgressor. We should also be wary of assuming, when a daughter is killed, that the mother knew about the killing but had nothing to do with plotting it. In the Dursun case study, we see that women sometimes try to prevent an honour killing by a male member of their family. When the wife of Mehmet Dursun found out that her husband and his brothers were planning to kill Zeynep, she telephoned Zeynep's neighbour to tell her to warn Zeynep. Her intervention was to no avail, however.

There are also instances of women who commit an honour killing after their *namus* or that of a daughter has been tarnished. From the *Hürriyet*:

(Kastamonu) The 27-year-old Melahat Kuru killed Emin, a 41-year-old restaurant owner, in front of the War Memorial. The woman turned herself over to the police, telling them that the man had been pursuing her for a long time: 'When my husband was away from home for a short while, he raped me. He said he wanted to see me again, so I arranged to meet him in front of the monument.'³¹

(Kırıkkale) The 30-year-old Menşure M. killed the 33-year-old Ekrem Kantekin because he had raped her 16-year-old daughter. Menşure invited the man to come to her home, where she confronted him with what she knew. A discussion arose, which ended with her grabbing the rifle and shooting him.³²

(Bulancak/Giresun) The 39-year-old Müşerref Çulfaz, the mother of three children, killed her neighbour, Mahmut Bay, with a pistol because he was constantly bothering her and had sexually assaulted her in her home. The

woman, who told the police that she had warned her neighbour many times, said: “He deserved the bullet.”³³

(Kastamonu) The 37-year-old Tefrika Tabaklı, married and the mother of two children, killed the husband of her sister-in-law with six pistol shots. Tefrika gave herself up to the police, saying: “He has been bothering me for a year. When he turned up at my door again, I killed him. I’m not sorry I did it.”³⁴

(Narlıdere/Izmir) Halime Özel, the mother of five children, killed the 16-year-old son of her brother-in-law because the boy had raped her 12-year-old daughter. She lured the boy inside on some pretext and then stabbed him three times with a knife. Then she gave herself up to the police, saying: “I have purified my *namus*” (*namusumu temizledim*).³⁵

3.5. Hired assassins

Tradition demands that a family cleanse its *namus* itself. It may be left to a minor within the family, but hiring someone to do the job is not appropriate. In his book *Tek yol*, Aziz Nesin, a well-known Turkish writer who was imprisoned for five and a half years for writing political satire, refers to cases of murder in which someone other than the murderer takes the blame for the crime and, in return for payment, sits out the prison term. Nesin expresses his surprise at this: ‘How is it that in a country where it’s cheaper to rent an assassin than to rent a house, people are still willing to commit the murder themselves and to then pay a huge sum to someone else to take the blame?’ Fellow prisoners informed Nesin that it is very dishonourable to arrange for someone outside the family to commit a murder out of revenge (any killing, not just an honour killing). You should kill the enemy with your own hands. Even if the enemy were to die unexpectedly or be murdered by someone else, revenge has – strictly speaking – not been exacted.³⁶

In the Dursun case study, members of the victim’s family were extremely insulted that a hired assassin had been called in. On the phone to the Dursun brothers, Temel, Zeynep’s brother, reacted as follows: ‘If you had any honour, you would have done it yourselves and not hired someone else to do it.’ The honour he is referring to is *şeref*: ‘real men’ do not leave it to others to purify their *namus*. Zeynep’s blood relatives would have been incensed that a hired as-

sassin was called in. This suggested that their sister and daughter was worth so little that the Dursun brothers were not even prepared to go to prison for their deed. In fact, that is the most likely reason that an assassin was hired. Because all three brothers had a family, none of them would have wanted to risk imprisonment. Kemal's children would have had neither a mother nor a father to look after them, and Mehmet and Gökhan may have been concerned about their prospects of finding work if they had a criminal record (in addition to running a coffee-house, Mehmet worked for Dutch Rail, where he had risen to the rank of shunter). We find another example of a hired assassin being engaged to carry out an honour killing in the Dağ case study.³⁷

THE DAĞ CASE STUDY: 'THREE CARTRIDGES ON THE BODY' (1989)

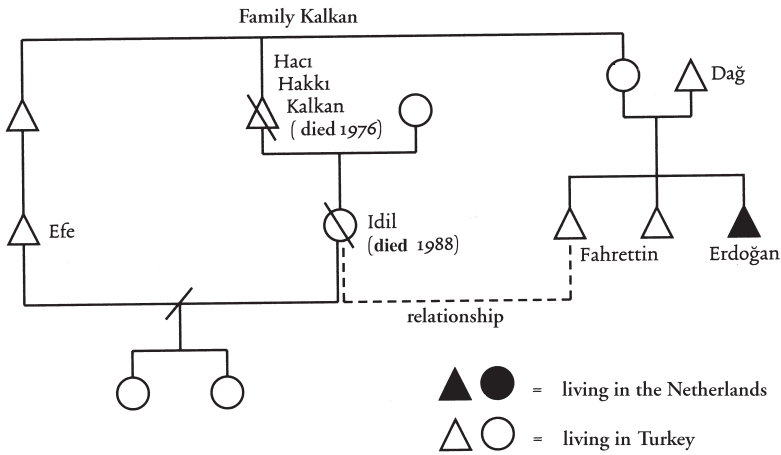

Fig. 5: The Dağ case study

Idil Kalkan is married to Efe Kalkan, a cousin on her father's side, probably her 'amca oğlu', the son of her father's brother.³⁸ They live in Turkey. Efe Kalkan is a known drug baron who deals in heroin. Idil and Efe eventually divorce and Idil is granted custody of their two children. Idil begins a relationship with Fahrettin Dağ, her 'hala oğlu', the son of her father's sister. When Efe learns about his ex-wife's relationship, he does all he can to gain

custody of the children but is unsuccessful. He is arrested for drug smuggling in Spain and is imprisoned there. From prison, he pays a certain Ayhan Kök to kill Idil. She is killed in July 1988 in Adapazarı in Turkey, at the age of 29. Ayhan Kök is assisted by five other men, all of whom were born in Adapazarı. All six are apprehended, but only the five accomplices sit out their prison sentence. Ayhan Kök, the lead perpetrator, manages to escape. After the killing, Efe Kalkan is awarded custody of the children. He has them taken to his parents in Turkey.

Fahrettin Dağ, the boyfriend of the dead woman, flees to the Netherlands where his brother Erdoğan lives. He is afraid that he too will fall victim to an honour killing. This fear is wellfounded: one evening in early January 1989, while sitting in a Turkish restaurant, he is asked to step outside. He is shot the moment he steps out onto the street. The murderer places three cartridges on his body.

Fahrettin Dağ was murdered in front of many witnesses. The witnesses were shown a series of photos of different men (including Ayhan Kök, whose photo had been sent by the Turkish police) and in eighty percent of cases, they identified Ayhan Kök as the killer. However, neither the Dutch or Turkish police were able to apprehend him. The Turkish police almost succeeded on one occasion but Ayhan then shot and killed a police officer. The Dutch police suspected that Ayhan Kök had been instructed to kill both the woman and her boyfriend. As a drug baron, Efe Kalkan would have had sufficient wealth to pay him well for his services.

An honour killing in Sliedrecht in 1978 demonstrated that calling in a hired assassin was already an option in the Netherlands at an earlier date. A Turkish outsider was initially approached to commit the killing. Only when he refused did the choice fall upon the eldest son, who was a minor. As the breadwinner, the father was probably reluctant to carry out the killing himself.³⁹

3.6. Disguised honour killing

Paying an assassin or having someone else sit out the prison sentence are ways of avoiding imprisonment that have probably evolved to meet modern-day circumstances.⁴⁰ Whereas in the past, the killer might easily be spared while he sat out his prison sentence (he would have worked on the family farm), the present-day job scene has made this more difficult. A prison sentence means losing your job, with lit-

the likelihood of a permanent job for the rest of your life. Kressel, who studied honour killing amongst the Bedouin in Israel, describes other ways in which murder is committed to avoid a lengthy prison sentence: the victim's body is thrown into a well to make the honour killing look like an accident or suicide; the victim is made to 'disappear' (in other words, the victim is killed and buried in secret, although an honour killing ought to take place in public); the victim is killed in the night to avoid discovery (although an honour killing should be committed in broad daylight); or the killer flees to Jordan, where honour killing carries a less severe penalty.⁴¹ In the *Hürriyet*, we find examples of disguised honour killings, in which the killing is made to look like an accident or suicide.

CASE STUDY: 'THE TRACTOR' (HÜRRİYET, 1995)⁴²

On 25 August 1995, Rabia Oğuz, a 25-year-old woman who is still single and lives with her parents in the village of Kısas köyü (13 km from Urfa), runs away from home to join her boyfriend Mahmut. However, she soon finds out that her boyfriend is married and she flees to the police. When her father comes to collect her, the police hand her over.⁴³ Back in her village, on 29 August 1995, she is run over several times by a tractor and is killed. The killers are her older brother Mustafa Oğuz, together with four other relatives: Halil Konak, Mikail Konak, Ismail Konak and Ismail Sevinç.⁴⁴ Many villagers witness the murder but nobody calls the police or tries to prevent it. Initially, her death is described as an accident. When the killers return to the village a day later, the villagers are astounded. Independently of one another, several people write to the governor of Urfa, the police and the city council to explain that it was not an accident. As a result, the case is re-opened again. Mustafa Oğuz is sentenced to life imprisonment for murdering a relative. Because, in the court's view, there was 'extreme provocation' (ağır tahrik), the sentence is reduced to 15 years. Thanks to 'good behaviour in court', the sentence is further reduced to 12 years and 6 months. The other four are sentenced to 20 years. In view of 'mild provocation' (hafif tahrik), their sentences are reduced to 15 years, and further reduced to 12 years and 6 months because of 'good behaviour in court'. Under the Implementation of Sentences Act, the killers will ultimately spend 5 years in prison.

The same newspaper article reported a similar case of honour killing two years earlier. A girl had run away from home and was thrown into a well to make it look like suicide. The girl's elder brothers were

sentenced to prison. The article cites Mehmet Alagöz, Chairman of the Bar in Urfa. He mentions three types of honour killing: one made to look like an accident or suicide, a planned killing where the killer takes responsibility for the deed, and an unplanned killing. It would appear that killings in which the perpetrator does not openly admit to the killing are not particularly rare and we should seriously consider them as a separate type of honour killing.⁴⁵

The mafia boss, Baybaşın, admitted to Bovenkerk and Yeşilgöz that he had once been responsible for a killing and had not confessed to it. A police chief had called him a 'bastard' during a press conference. According to Baybaşın, when the officer was not ordered to retract his statement, Baybaşın was forced to adopt another approach: the police chief was killed in an accident.⁴⁶ In the 'Euphrates' case, reported in the *Hürriyet*, the perpetrators sought to hide the fact – from the police at least – that it was an honour killing. It had to appear like death by drowning. The girl probably survived the murder attempt because her attackers could not be too violent; otherwise it would have been immediately apparent that murder was involved.

In the Bitlis 3 case study, the victim 'disappeared'. Three brothers killed their adulterous sister and hid her body in the mountains. They then spread the story that their sister had run off with a soldier, which for them was less serious than her staying in the village community and continuing to commit adultery.⁴⁷

3.7. Dutch jurisprudence and honour killing

In its justification of the sentence it passed down in the Dursun case, the court expressly condemned the phenomenon of 'honour killing': '[...] the victim's life [has been] taken because she is said to have transgressed certain feelings with regard to sexual morality and honour. The court [...] wishes to make it absolutely clear that, under Dutch law, such feelings can in no way provide a justification for an act of violence as in this case. Nor under any circumstances can the motive for taking someone's life, arising from such feelings, lead to a reduced sentence. In this respect, the sentence to be passed should also serve as a deterrent.'

This is not the only case in which a court has explicitly rejected codes of honour. In the case of Utlu, whose wife ran away, the court justified its sentence on the following grounds: 'The defendant, who saw himself as the cheated husband, was determined to restore the

loss of face that he felt he had suffered vis-à-vis his friends and his ethnic community – and in so doing he exceeded all bounds.’

The counsel for the defence sometimes focuses on the obligatory nature of honour killing, as in the case of Akkaya, who killed his wife and her alleged boyfriend: ‘The suspect could not have acted any differently because the customary law⁴⁸ in his native region, together with his religious convictions, carried such imperative force that there was no other way open to him than to kill them both to protect his honour.’ In the Netherlands, such an argument for the defence does not lead to a reduced sentence. Instead, it has the opposite effect: the court feels compelled to strongly condemn the defendant’s actions ‘because the accused [...] was well aware that the Dutch legal system, under whose jurisdiction he has been living for ten years, rejects outright the course of action he defends[...].’ The same happened in the Ayanoglu case, in which the court gave the following reasons for its sentencing of Ayanoglu (eight years for murdering his wife’s boyfriend): ‘Although the court has some sympathy for the fact that the wife of the accused was having a relationship with another man and that, for reasons of cultural origin, this had severe implications for the accused, these circumstances provide absolutely no justification for the offence committed by the accused.’

Thus, in some cases the court feels obliged to explicitly state its unwillingness to take into account the Turkish culture’s practice of honour killing. The court also says that honour killings should be punished as a deterrent to other Turks. General sentencing practice, however, reveals that the courts do not strictly adhere to this view; the court examines the motives of the defendant in each case and in so doing takes the defendant’s culture into account.

We must ensure, however, that this does not lead to inequality before the law, as some honour killings are easier to accept than others. Dutch people may be sympathetic towards a man whose wife is having an affair or a father whose daughter has run off with an older man, but what of Mehmet Dursun, who killed his brother’s wife? They would feel that it was none of Mehmet’s business; after all, he was only the brother-in-law. For a Turk, however, a brother’s wife is very important as she has married into his family. Honour killings of female members within a family are also less likely to be understood than killings of male transgressors from outside the family. This could lead to a situation in which less severe penalties are given to honour killings which Western Europeans are likely to sympathise with than to killings they have difficulties comprehending. Such in-

equality before the law is exacerbated by the fact that those convicted of honour killings that have lived in the Netherlands for many years, but do not have Dutch nationality are in principle deported from the Netherlands after serving their prison sentence.

Also relevant to sentencing is the way in which the defendant approaches the court. In the case of honour killings, the accused usually feels an immense sense of relief and happiness that his *namus* has been purified. But it would not be prudent to say this in court, or when questioned by the police: the accused can then count on a severe sentence (12 years imprisonment for murder in the Türkmen case). A more successful strategy would be to plead self-defence. If the defendant expresses regret and is able to show that the honour killing occurred in a fit of rage, the sentence may be drastically reduced (5 years imprisonment for manslaughter in the Tekin case).

If honour killings become associated with harsher penalties, it is possible that this will not lead to a reduction in the number of such killings. At most, honour killings may instead assume a different form, such as more minors taking responsibility for the killing, greater recourse to hired assassins, more disguised honour killings, and perhaps more killings during holidays in Turkey. There is also a greater chance that perpetrators will deny that it was an honour killing, as in the 'Love in the factory' case study, in which Ayanoglu killed his wife's boyfriend. Ayanoglu kept insisting that it was not an honour killing. He had heard that honour killers were given particularly severe sentences because the Dutch state wanted to outlaw such killings. It is plausible that Turks should think this way because of the attitude of the Turkish state toward blood revenge. Such emphatic denials, however, rob the courts of greater insights into the crime. Tougher penalties for minors who have committed honour killings would probably be more effective, as this might put a swift end to the practice of selecting minors to commit honour killings.

It would not be advisable for honour killings to explicitly carry a lighter sentence. This would lead to 'honour killing as camouflage', whereby murder or manslaughter is presented as an honour killing to take advantage of the grounds for sentence reduction.⁴⁹

4. Marriage and elopement

As Turkish marriage and elopement procedures vary from region to region, I can do no more than briefly outline them here. In general, it would be true to say that it is still quite common for parents from rural backgrounds to arrange their children's marriages. This does not necessarily imply that they do so against their children's wishes. Often the children have informally reached an agreement, but it is still the parents who must give the official go-ahead.¹ The boy's family is the active party; they go in search of a suitable *gelin* (bride, daughter-in-law). The girl's family is expected to wait until an offer of marriage is made. All preparatory work is carried out by the boy's mother. Once she has a girl in mind, she and several female relatives call on the girl's mother. At a certain point, the girl comes in to serve tea.² This stage is called *görücülük* (literally: looking).

Only when the mothers are in agreement does the boy's father come to make the official request. Although the boy may accompany his father, he is not the spokesman. The evening follows a set pattern: it is customary for the girl to serve tea, after which the boy's father makes an official request for the girl's hand in marriage for his son. He uses the standard formulation, *Allah'ın emriyle, peygamberin kavliyle, kızınızı oğlumuz için istiyoruz* (By the order of God and at the intercession of the prophet, we would like to have your daughter for our son).³ If the girl's father does not want the boy as a son-in-law, he says so tactfully. Usually, however, this is not necessary, as his wife will already have given her refusal. It can be very embarrassing for the girl's father to be faced with a request that he does not favour, just as it is humiliating for the boy's father to have an offer of marriage turned down.⁴ For this reason, the role of the women should not be underestimated.⁵ It is probably not coincidental that the Turkish term for arranging a marriage is *görücü usulle evlenmek* (marrying by means of a *görücü*, or 'one who looks'). This type of marriage derives its name from the preliminary work done by the women (*görücülük*). Similarly, the stage at which the men become involved is called *dünürçülük* or *dünürlere gitmek* ('going to the *dünür*': the par-

ents of a couple are each other's *dünür*). The nomenclature of the ritual shows that the matter is all but settled.

The importance attached to this ritual is demonstrated by a number of honour killings that occurred when protocol was not observed. In the Yiğit case study, the girl's father approached the father of the boy and insisted that their children should marry. The Tekin, Elmas and Ardal case studies involve elopements, the standard means of circumventing the official system of arranged marriages. Elopements usually lead to the desired marriage, but in these cases, they resulted in an honour killing.

4.1. The rejected marriage proposal

THE YIĞIT CASE STUDY: 'THE WEDDING' (1984)

Yiğit, who was born in 1941 in the village of Buğday in Central Anatolia, migrates to the Netherlands in 1969 as part of a group of men from his village. He leaves his wife and three children behind. Yiğit ends up working for the same company as Akan, who lived opposite him in their native village. They spend a lot of time together. Like the other men from his village, Yiğit arranges for his wife and children to come to the Netherlands in the summer of 1974. Akan is the only one to bring only his eldest son. In 1978, Akan moves to another town in the Netherlands in order to get a better job.

In 1980, the Yiğit family takes a holiday in Buğday. Ayşe Yiğit, the 16-year-old daughter, meets Ahmet Akan, the neighbour boy, in her family's shed. Ayşe's father walks in unexpectedly, and Ahmet immediately takes off. Yiğit beats Ayşe and sends her, together with her mother, to her 'teyze' (mother's sister) in a neighbouring village. Ayşe and her mother are picked up again a few days later. Nothing more is said about what happened and Ahmet does not try to contact Ayşe.

Zafer, Ayşe's brother who is three years her junior, explains what happened in the days that Ayşe was away. His father went to Mrs. Akan to say that Ayşe and Ahmet had to get married. He asked her to contact her husband in the Netherlands so that he could come to Turkey for the wedding. However, Akan sent a telegram saying that he had no intention of coming and that he did not want his son to marry Ayşe. Yiğit was so enraged by this that he threw a stone through a window in Akan's house. It was not long before the entire village knew about the incident.

Back in the Netherlands, Yiğit hopes that Akan will get in touch with him, but he does not. When Yiğit travels alone to his native village in the summer of 1982, the Akan family avoids him. In the Netherlands, others from Yiğit's village try to mediate. Not until May 1983 do the mediators make their proposal to Akan: that he should permit a marriage between his son, Ahmet, and Ayşe Yiğit. In the summer of 1983, Yiğit returns to Buğday for the first time with his wife and children for a holiday. His son Zafer explains: 'I thought we were going for my sister's marriage to Ahmet, not just for a holiday. My father had made several phone calls to my mother's brother in Turkey to arrange things. I presume, to talk Ahmet into marriage.' When the Yiğit family arrives in Buğday, Mrs. Akan and her three sons are not there. That summer is a disaster for the Yiğits. Nobody comes to ask for the hand of Ayşe, who by now has turned nineteen. It seems that the Akans have spread rumours about Mrs. Yiğit and her daughter: they are said to wear 'revealing clothes' in the Netherlands. Zafer calls this a 'gross insult'.

Back in the Netherlands, Yiğit receives a letter from the husband of his wife's sister. It seems that the Akans have been telling everyone that Ayşe goes out with many men. Zafer says: "My father was completely shaken by the letter." In the Netherlands too, Yiğit is unable to arrange a marriage for his daughter, since everyone in the Turkish community has now heard about what happened.

In the spring of 1984, in the Dutch town where the Yiğit family lives, the wedding of the son of Bilgin, a good friend of Yiğit who also comes from Buğdağ, is scheduled to take place. On the day of the wedding, Mr. and Mrs. Yiğit help with preparations. They leave early to pick up one of the bridesmaids, and that evening they will assist with serving the guests and filling glasses. Bilgin tells the police later that he had not invited Akan to the wedding because he knew about the problem between Yiğit and Akan. But when Yiğit walks to the building where the wedding is being held, he comes face to face with Akan. Yiğit later tells the police what happened: 'I was busy rolling a cigarette. When I was about 15 to 20 metres from the entrance, I bumped into someone. I dropped my cigarette. When I bent down to pick it up, I saw that it was Akan. From that moment everything went black. I grabbed my gun and shot Akan. When a police car drove up, I stopped it. I said to the police officers: "I did it." I handed the gun over to the police.'

Later, when interrogated by the police, Yiğit says that Bilgin followed him and called out: 'Yiğit, you've stained my wedding with blood. God will punish you.' When the wedding guests hear the shooting, they all come outside. An hour later, they are back inside again. Bilgin takes the microphone and explains what has happened. He apologises, saying that he had invited

one of the two men involved but not the other. The 300-odd guests congratulate the couple and present their gifts, after which everyone goes home. Akan died as a result of three gunshot wounds (to his back, chest and left hip).

In this case, the girl's father urged the father of the boy to let his son marry his daughter. Customary practice, however, requires the father of the girl to play a passive role in this respect. The unexpected marriage proposal, which was presented as a command, placed Akan on the spot. He was keen for his son to go to university and had not yet given any thought to his son's marriage. Zafer Yiğit revealed under questioning that his father did not abandon hope. The family returned to their village three years later with the purpose of marrying Ayşe to Akan's son. Only then did it become clear to Yiğit that marriage between his daughter, Ayşe, and Ahmet Akan was completely out of the question.

In the courts, discussion revolved around the question of whether it was murder or manslaughter, with the case going right up to the Supreme Court.⁶ Yiğit claimed that he was so shocked at seeing Akan that he shot him for fear of being killed himself. However, Yiğit, his son and his wife, all made incriminating statements during the first police interrogation. Yiğit said that he knew he would shoot Akan if he met him. The likelihood of such a meeting was quite high, given that fellow villagers do not need an invitation to attend weddings of children from the village. Yiğit's sixteen-year-old son claimed that Yiğit had shown him a gun two weeks earlier, saying that he would kill Akan with it 'in order to erase the dishonour.' Yiğit's wife said that he had bought a gun about six months earlier. All three retracted their statements later: Yiğit claimed that he never said he intended to shoot Akan, his son claimed that nothing had been said about killing, and his wife said that he had had a gun for ages and had not purchased one especially for the purpose of killing Akan.

The key arguments put forward by the defence, in addition to self-defence, were the following. When meeting Akan, Yiğit suddenly became aware that the honour of his family had been compromised. In addition, the defence argued that Yiğit had avoided his former neighbour for a long time because he did not want to commit an honour killing. So why should he all of a sudden have a reason for doing so? Yiğit was resolved not to attend the wedding. Only when

the father of the bride urged him to come, and asked for his help, did he relent, according to the defence.

It is significant here that it was the forthcoming wedding that drew Yiğit's attention to his injured family honour; this realisation did not suddenly dawn on him when he happened to meet Akan. Yiğit was saddled with a daughter who could not be married and the wedding was a painful reminder of this fact. The weddings of the children of fellow villagers must have been very distressing occasions for Yiğit, so it is understandable that he initially declined the invitation. We cannot be sure whether he later relented because the bridegroom's father asked him to come and help or because he had since come up with plans of his own. The defence argued that it was highly implausible for Yiğit to commit an honour killing after having done nothing for three and a half years. However, Yiğit had cherished the hope for three years that his daughter would still marry. Not until they returned to their native village for the first time after the incident in the shed did they realise the hopelessness of the situation. In my opinion, it was only then that Yiğit began to despair and to comprehend that the disgrace to his *namus* could not be eliminated so easily.

Surprisingly, the defence did not point that out; in a case of premeditated murder, the father would normally appoint his son to do the killing. His son was the right age: sixteen – old enough to carry out the killing, yet young enough to get off lightly with a minimum prison sentence. However, Yiğit was afraid of Akan. He explained it himself in the following terms: Akan was a member of the Grey Wolves and had a history of violence. Perhaps Yiğit did not dare leave the deed to his son. Nor did the defence raise the issue of the scene of the killing. They could have said in Yiğit's defence that he would never have wished to upset the wedding of a good friend's son. On the other hand, the wedding was the ideal occasion for an honour killing. It is a public place *par excellence*, and all the villagers who knew of Yiğit's loss of *namus* were present.

It is not beyond the realm of possibilities that Bilgin, the father of the groom and a very good friend of Yiğit, was aware of the planned honour killing and gave it his seal of approval. However, the court records show that the police harboured no such suspicions. The magistrate's court, the high court and the Court of Appeal all sentenced Yiğit to eight years in prison for murder.

In the Koparan case study, we find another honour killing following a rejected marriage proposal. In this case, the Gürdals, father and

son, were highly insulted when their proposal of marriage was turned down by Koparan, the girl's father. The son started hanging around the girl threateningly and the family was afraid that he planned to abduct her. Gürdal Senior threatened Koparan and made sexual insults. Eventually, Koparan felt that he had no option but to kill Gürdal Senior, the boy's father.

4.2. Elopement

The system of arranged marriages functions best when the sexes are strictly separated. Then the boys and girls do not know one another and it is the parents who decide who their child will marry. However, segregation of the sexes is not quite so strict in rural Turkey, and young men and women have opportunities to become acquainted.⁷ Traditionally, weddings and *Hıdırellez*, the spring festival on 6 May, are times when young people fall in love. This does not mean that they get to know one another well; they are simply attracted by the other's appearance or behaviour. They exchange knowing glances or have young children act as messengers.

If the young people are agreed, the young man asks his parents if they are willing to begin the marriage negotiations. Thus, it is the parents who officially arrange their children's weddings. If the parents do not support the marriage, rural Turkish culture offers a solution in the form of *kız kaçırma*, or elopement. Officially, this involves the boy abducting the girl with the purpose of marrying her. In practice, she is usually not an unwilling victim. She decides to elope with the boy because her parents oppose the marriage. Elopements are often motivated by economic considerations. The girl's parents are concerned that the boy will not be in a position to support their daughter. Boys who are involved in elopements are generally poor.⁸ It is very important in Turkey for a girl to make a good match: if she cannot look after herself, she becomes a burden to her family. Marriage to a boy from a poor family increases the likelihood that the girl will later seek financial support from her father.

Parents' objections to a marriage may be of a temporary nature. They may feel that their daughter is still too young, or that it is not yet her turn to marry as she has an older unmarried sister. Elopements under these circumstances, where everything hinges on the time aspect alone, are not viewed as seriously as when parents feel that the choice of marriage partner has been forced upon them.

A young man and woman may decide to elope if the girl is not free to accept a marriage proposal because she has been promised to someone else. In such a case, there is a risk of serious problems with the family of the girl's fiancé. In the Bitlis 4 case study, we see how one such family attacks and injures the family of the runaway girl (their future bride). In the Uzun case study too, the family of the prospective bride, who live in the native village, are highly insulted by the elopement.

A young couple may resort to an elopement because both sets of parents are so intent on having an expensive wedding that they keep postponing it until enough money is saved. When my husband and I visited Turkey in 1997, our driver was Erdinç, a man from Fethiye in south western Turkey. As he took us around his local district, he told me that those were his reasons for eloping with his wife, Aliye: 'Our parents just kept on squabbling about who should pay for what. We got so sick of it that we eloped.' Their children's wedding is a matter of *şeref* for parents (a *gurur meselesi*, or 'question of pride', as Erdinç called it). It is not simply a question of putting on a grand wedding. The parents are also expected to set up house for the young couple, which – in towns and cities at least – almost never live with the parents. This can entail great expense as all furniture and fittings are purchased new.

The converse is also the case: both sets of parents support an elopement as a means of avoiding the costs associated with an expensive wedding.⁹ For this to happen, the girl must be in agreement. Erdinç drove us to the village of Arpacık in Fethiye Province, where the 25-year-old Nazife said she had broken off an earlier engagement (*nişan*). This was prompted by her future in-laws' proposal that she go to the house of their son's *hala* (father's sister), where their son would also be present. "That was it for me," she said. "Then it would have been a kind of elopement and the boy's father would have been spared the expense of a wedding." Nazife felt she had a right to a wedding because, as she put it, "there's nothing wrong with me." By this she meant that she was *namuslu* (honourable), and a hard worker.

We might easily conclude that the option of eloping puts the system of arranged marriages under pressure. However, Wertheim suggests the opposite. In societies where arranged marriages are the norm, this practice owes its continued existence to the fact that elopements are possible.¹⁰ Elopements act as a safety valve; they are seen as a means by which love matches can take place, without affecting the system of arranged marriages.

Young women are often the ones who take the initiative in an elopement. They sometimes have to put pressure on their boyfriends to elope because not all young men have the courage to take such a step.¹¹ One form of elopement where the initiative rests fully with the girl is *oturakalma* (literally, 'staying put'). Here, the girl leaves her parents' home and goes to her boyfriend's house, where she tells the boy's parents that she wishes to marry their son.¹²

If a girl's parents respond negatively to her leaving home of her own accord, the girl can claim that she was abducted. After all, a girl who leaves home of her own volition to join a young man is *namussuz* (without *namus*). The blame will fall upon her parents, particularly her mother, who has clearly brought her up badly. If a girl is abducted, she can at least claim that it was beyond her control. For the boy too, it looks better if the elopement is presented as having been initiated by him as it adds to his manliness (*erkeklik*).¹³ The more brothers a girl has, the more dangerous an elopement is perceived, because a girl's brothers are seen as her ultimate guardians.

Wherever possible, the elopement takes place when the girl is not in the company of her mother and other relatives. Only if left with no other choice does the couple stage an abduction, whereby the girl is carried off 'by force' by her boyfriend and his helpers. The couple live at a secret address until the girl's parents agree to the marriage; otherwise she runs the risk of being fetched home again. A mediator is called in to negotiate with both families. In the case of an elopement, a wedding party is not necessary. After all, the girl has already been transferred to the boy's house: bride and groom have already been living together for some time.

Elopement is an effective means of bringing about a marriage. Once the girl has spent a night with her boyfriend, her *namus* is compromised and she has brought great shame upon her family. Her family will want her *namus* to be purified as soon as possible, which they do by allowing her to marry her boyfriend. The girl's family is often confronted with a *fait accompli*: the couple are already secretly married before they contact the girl's parents through a mediator. In order for a civil marriage to take place, the girl requires a passport or other means of identification. However, she is not always in a position to take these documents with her when she leaves. For an *imam* marriage on the other hand, no documents are required, and it is this type of marriage that we usually encounter at this stage of an elopement.

Married women may also elope, in which case it is called *kadın kaçıırma* (*kadın* meaning 'woman'). Such cases usually involve a young, recently married woman running off with her boyfriend after a marriage forced upon her by her parents. Elopements of this kind are much less common because of the risks involved. The standard solution – marriage following the elopement – is not an option because the woman is already married.

Elopements, in the western coastal provinces at least, occur so frequently that they have almost become a legitimate means of evading strict marriage rules. Their frequency in Adapazarı Province in western Turkey, which lies between Istanbul and Ankara, has given rise to the saying: 'No elopement, no marriage.' There, the need to stage an abduction has also been dispensed with. The girl simply slips out at night to join her boyfriend who is waiting for her. The fact that this is done so quietly makes it clear to everyone that she left of her own free will; otherwise there would have been a disturbance of some kind. The couple then leave together to spend the night with friends in another town. The following day, they let their parents know through an intermediary that they wish to get married. The girl herself may even ring home to announce '*Ben kaçtım*' (literally, I have run away), which implies that she is with a boy. According to Erdiñç, our driver: 'Nothing has changed except that girls used to elope on horseback and they now go by motorbike'.

The fact that elopements run so smoothly does not imply that the girl's father and brothers do not feel insulted. Although there is widespread acceptance of elopement in western Turkey, this is less the case if a family's own daughter is involved. We encountered this attitude when Erdiñç drove us to the mountain village of Çenger, where we visited the Topal family. When we asked them whether elopements occurred in their region, they replied in very general terms. Later, when Nurgül, the married daughter, went to the kitchen, I followed her and she began to tell me all about her own elopement. Her mother, Naime, also in the kitchen, joined in enthusiastically. Realising what was happening, the father, Ibrahim, hurried in. I was worried that Nurgül would stop telling her story, but she continued. It was clear that her father felt uncomfortable and, while the women were talking, he tried to convince my husband Bahadır that there was absolutely nothing he could have done to prevent the elopement. He could not hear the sound of the motorbike above all the noise of a wedding in the village. "The poor man," said Bahadır to me later, "he

was trying to show his manliness [*erkeklik*], but nobody listened to him.”

Nurgül’s brother was also angry that his sister had eloped. His reaction was even stronger than that of his father. He did not speak to Nurgül for two years after the elopement (this is known as *küs*). But the mother had no objections. Naime pulled me outside at one point so that her husband could not hear, and said with tears in her eyes: “*Beyim çok ters*” (My husband is very difficult). He was not at all an easy man to live with, which is why she was pleased that her daughter had planned an elopement. “That way she marries the man she wants. It makes life easier,” she said.

Some elopements have the support of the girl’s father, for instance when a girl elopes with the son of a rich family. His protest is then simply a matter of form. In such cases, the boy’s parents do not support the elopement; after all, the elopement would have been superfluous if they had supported the match.

Unlike elopements, in which girls go of their own free will, abductions also occur, whereby girls are taken against their will. This may seem incomprehensible; after all, what could a boy possibly wish to achieve? But in a society where parents arrange a girl’s marriage and the girl in many cases does not love her future husband, it is not unusual for the abductor to imagine that love will develop after the wedding. The abductor acts on the assumption that the girl will see no choice but to accept him as her husband once he has abducted and deflowered her. It tends to be village girls and girls with no education who submit to the demands of the abductor. For such girls, marriage is their only prospect, and they would have little chance of finding a good husband following an abduction. The fear of remaining unmarried (*evde kalmış kız*, the girl who stayed at home) is worse than marrying the abductor, who does at least seem to love her. The girl accepts her abductor as her husband and claims that she eloped. She does not reveal that she was abducted, for fear that her abductor will go to prison and can no longer marry her.¹⁴

It is not always easy to tell whether a girl has eloped or has been abducted. If abducted, she may claim that she eloped. Conversely, if she eloped, she may claim that she was abducted because she does not want to be regarded as *namussuz*. This tends to happen if an elopement fails and the girl is returned to her parents’ house. In such a case, she will not want to make her situation at home untenable by admitting that she ran away. To avoid being charged with abduction, the boy will claim as a matter of course that the whole undertaking

took place with the girl's consent. If it is not clear whether elopement or abduction is involved, the *Hürriyet* asks: *Kız kaçtı mı kaçırıldı mı?* (Did the girl run away or was she abducted?). Analogous to the 'rape' claim in 2.2, we may call this an 'abduction' claim. One example from the *Hürriyet* is the Ülkü case.¹⁵

Ülkü is just married when she and her husband go to her grandfather's summerhouse. She leaves again with her former fiancé. Her husband and father are furious, claiming that she was abducted. But the newspaper reports that Ülkü was unhappy during the wedding celebration, as she would rather have married her former fiancé. The two of them must have planned the elopement. Things get out of hand when the two brothers of the former fiancé are killed, probably by Ülkü's father. Ülkü then returns to her husband, saying that she had been forced into it. "I was abducted. When he heard that his brothers had been killed, he wanted to kill me. I managed to escape just in time," she declares. But her 'abductor' tells a different story: 'Ülkü fled to join me. She was unhappy in her marriage and yearned for me. I agreed to 'abduct' her.'

It is likely that both Ülkü and her 'abductor' continued to adhere to their own version of events. Ülkü returned to her husband (for fear of revenge from either her former fiancé or her father) and could no longer say that she had left voluntarily. The fiancé would certainly not admit, even if it were true, that he had abducted Ülkü, as he would then risk a prison sentence, at best.

An abduction claim also appears in the Ayanoğlu case study. At the police station, Mrs Ayanoğlu claimed that she was abducted by Nuri Sakal, who forced her to live with him for five days before taking her to a reception centre. Her husband then killed Nuri Sakal. However, she had not been abducted and her husband knew it. Ayanoğlu had seen his wife walking arm-in-arm with Nuri Sakal and had also been warned by various people that his wife had a lover. He probably told his wife what to say to the police. This is all the more likely as, in her initial statement to the police, Mrs. Ayanoğlu was very positive about Nuri Sakal and very negative about her husband. It was not until she was questioned a second time that she came up with the abduction story.

It is not simply after the event that we have difficulties deciding whether an elopement or abduction is involved. This is also true at the time of the incident itself. One such example was the Elif case study, which kept *Hürriyet* readers enthralled for days.

THE ELIF CASE STUDY (HÜRRIYET, 1994)¹⁶

Elif Cihan is a 17-year-old Turkish girl who lives in Kassel in Germany, where she works for a law firm. She goes on holiday with her parents to Trabzon. Three weeks later, she is abducted by the 23-year-old Faruk Cinemre. The parents call in the police to track down their daughter. They also enlist the help of the newspaper, asking them to write about the case in the hope that someone will find the couple. They claim that the girl was obviously taken against her will as she already has a fiancé in Germany. When Elif calls her parents a week later, saying that she wants to marry Faruk, her parents cannot believe their ears. Three weeks go by and Elif and Faruk turn up. They are married and Elif tells the newspaper reporter that she is very happy. She returns to her parents and goes with them to Kassel. There she tells the reporter that she was forced into the marriage. She had to pretend that she wanted to get married or else Faruk would not have let her go. Fortunately, with the help of the lawyers at the firm where she works, she is able to have her marriage annulled. It is clear from her story that her parents did not force her into giving up the marriage.

Elif's conversation with the *Hürriyet* reporter is interesting because it gives us insights into how the *namus* code works: "Turkey is a strange country. If you're nice to a boy, it's misinterpreted. I had only spoken twice to Faruk because he was a friend of an acquaintance of my cousin. But after that he wouldn't leave me alone. Then he abducted me because he was crazy about me and thought I would feel the same way about him."¹⁷

A look, a greeting, or a friendly word may be all it takes. In a country where, generally speaking, so little is permitted between the sexes, a girl can signal her love with the slightest of gestures. For the rest, she has to be particularly cool and standoffish. This makes it difficult for a young man to find out whether she really does not wish to be approached or whether she is simply pretending. It becomes all the more difficult if a friendly chat or even a smile has led him to suspect that she likes him, as happened in the Raman T. abduction case in the Netherlands.¹⁸ Raman, a Turkish boy, abducted a Turkish girl who worked at the same sewing factory. The presiding judge of the Dutch court asked: "What made you so certain that she wanted to go with you?" The defendant replied: "The way she looked and smiled at me as she worked." We see something similar in the Asiye case study.

THE ASIYE CASE STUDY (1981)¹⁹

Yaşar, a young Turkish man of seventeen, who is living illegally in the Netherlands, occasionally visits the home of Asiye (aged 15) and her Turkish family. However, when his uncle asks for her hand in marriage on his behalf, the proposal is rejected. One day, when Yaşar waves from his balcony to Asiye's balcony, where she is working, she waves back. Interpreting this as a clear signal from her, Yaşar decides to abduct her. He and members of his family intercept her as she walks to Dutch lessons at the community centre. Her sister and two teachers witness Asiye being dragged into a car.

The issue of whether a girl has eloped or was abducted can be resolved by questioning the girl independently of her 'abductor' and her parents. This allows her to keep her options open, namely, to go back to her parents or to marry her 'abductor'. She needs to be told that her parents want her back, in spite of what has happened. This leaves her free to say honestly what she wants, as happened in the Sefiye case.

THE SEFIYE CASE STUDY (1981)²⁰

Sefiye, a 15-year-old Turkish girl, is abducted by Ahmet, who is living illegally in the Netherlands. When police officer Nellestein manages to track them down, Sefiye tells him that she went with Ahmet voluntarily. Only when she is alone in the car with the officer and he tells her that her father will not disown her does she tell the true story. Ahmet had abducted and raped her and she saw no option other than to accept him as her husband. The girl returns to her parents and Ahmet appears before the court.

The Asiye case study, referred to earlier, is another in which the girl did not dare say exactly what had happened. Like Sefiye, Asiye was abducted and resigned herself to her lot. Her abductor, Yaşar, and one of his female relatives worked on her, telling her that her father would not want her back and would shoot her because she had been abducted. Convinced that her situation was hopeless, Asiye did not resist the *imam* marriage, which took place the day after the abduction. She was immediately deflowered, and the following day was rescued by the police. When Asiye told the police that she had gone willingly, they were obliged to release all those involved and to return Asiye to her father.²¹

When the police interrogated Yaşar and the others involved, it was immediately apparent that Asiye had been abducted. Although popular opinion has it that an *imam* marriage soon afterwards points to an elopement rather than an abduction, the case of Asiye, who went through with an *imam* marriage the day after the abduction, reveals that this is not always the case. As a traditionally brought-up girl, she had been quick to view her situation as hopeless. Even before being deflowered, she accepted her abductor as her husband.

The central question in the case of Türkay, a Turkish girl living in the Netherlands, was whether she eloped or was abducted. She maintained the latter. However, her statement was called into question because she was returned to her parents afterwards. Perhaps she did not dare say that she had gone of her own accord. We can reconstruct the story from the court records.

'TÜRKAY'S ELOPEMENT' (1987)

In 1987, the Yıldız family, a Turkish family living in the Netherlands, receives a phone call telling them that their youngest daughter, Aytaç, has just been involved in a car accident. Mrs. Yıldız and her 16-year-old daughter, Türkay, run straight out into the street. Türkay lags behind a little. A car with four young men in it then pulls up. One of them jumps out and, with the help of the others, pushes Türkay into the car. Türkay screams and shouts, struggling to free herself. Mrs. Yıldız also starts screaming. She recognises three of the four young men: they are sons of the Akkır family, a Turkish family who lived next door for many years before moving to the west of the Netherlands. Mrs. Yıldız tries to save her daughter but is too late: the car drives off with Türkay in it. Mrs. Yıldız rushes inside and phones the police. She is able to give a precise description. The police manage to intercept the car an hour later. Türkay is returned to her parents. She presses charges and the four young men are arrested and charged with abduction.

Yâsin Akkır, the 23-year-old abductor, claims that he and Türkay planned the abduction together. They wanted to get married but Türkay's parents would not give their consent as Türkay had been promised to another young man. They decided to stage the 'abduction' when Türkay's father was away from home. When the time came (Yıldız went to Turkey for two weeks), they arranged for Türkay to go shopping one Saturday and be 'abducted' en route. On the appointed day, Yâsin and his helpers waited near the house but

Türkay failed to appear. Her younger sister Aytaç came out several times on various errands. According to Yâsin, Türkay's mother was deliberately keeping her indoors, so he decided on a ruse to get Türkay out of the house. When Aytaç once again left the house, he made an anonymous call to tell Mrs. Yıldız that her daughter had been involved in a car accident. It worked. Both Türkay and her mother came running outside. Yâsin said that Türkay deliberately stayed behind a little so that she could be picked up. Mrs. Yıldız claimed however, that her daughter lagged behind because she was wearing a tight skirt and could not run very fast. She also said that her daughter was hit by the young men. Türkay said nothing on the subject. Was Türkay trying to protect her boyfriend, the 'abductor', or was her mother exaggerating Türkay's resistance to emphasise her daughter's virtue?

The probation officer wrote a lengthy report in which, on the basis of talks with Yâsin, he described the abduction as the only way the two lovers could marry. However, Yâsin eventually admitted that it was his parents' idea to abduct Türkay; neither he nor Türkay had wanted it to happen. Another probation officer wrote that it was unusual for Yâsin to make such a statement: 'By saying this, Yâsin was violating one of the most stringent laws of Turkish society: never betray your parents to the outside world.' It seems that Yâsin had established such a rapport with the probation officer that he regarded him as a friend to whom he could entrust a secret. The probation officer, however, felt obliged to report the truth. He advised that Yâsin should not be forced to repeat his statements in court. Yâsin would be confronted with a moral dilemma if forced to tell his story in the presence of his parents.

So what really happened? The Akkır and Yıldız families had lived next door to one another for years and were good friends. In fact, they were even related. Mrs. Akkır was a daughter of the elder brother of Yıldız. When Mrs. Yıldız went to work, Mrs. Akkır looked after the little girl, Türkay Yıldız. She did this from the time Türkay was three years old until she turned eleven.

Then the Akkirs moved to the west of the Netherlands. After a time, their son Yâsin became acquainted with a Dutch girl, Heleen, and they moved in together. This was a thorn in the eye of Yâsin's parents. Akkır was a pious Muslim, who did not want his son living with a non-Muslim. He could think of only one effective measure: to marry his son to a Muslim girl as soon as possible. Mrs. Akkır knew who she wished to have as a daughter-in-law: Türkay Yıldız, the

neighbour girl whom she had looked after for so many years and who was also a daughter of her father's brother (*amca kız1*). Yâsin did not dare oppose his parents. It had been drummed into him from a very early age that he must obey his father. However, his primary reason for giving in was his mother's fervent wish to have Türkay as a daughter-in-law. Yâsin did not want to disappoint his mother, whom he loved dearly. At the same time, he told his girlfriend, Heleen, that he would always love her and that she would remain his girlfriend. His marriage to Türkay was simply an obligation towards his parents.

We must view Yâsin's attitude in the context of the traditional culture of provincial Turkey. If a girl marries at a young age, she and her husband move in with his parents. The relationship between mother-in-law and daughter-in-law is a very important one. Young men understand this, and see their ideal wife as someone whom their mother will get on well with.²² A man is not expected to spend much time at home, so Yâsin believed that he would still have plenty of time for his Dutch girlfriend after his marriage. I should point out that this is not the proper thing in Turkish village culture, but it does happen (see the Dursun case study).

What is unusual about this abduction is that the boy himself did not support it. Neither of the parties involved wanted the abduction. In his report, the probation officer emphasised that none of the participants had anything but good intentions. Akkır believed he was setting his son, who had gone astray, back on the right path; Mrs Akkır wanted to heap her love upon her niece Türkay; Yâsin and his two brothers had acted out of a sense of duty towards their parents; and Yâsin's friend would have thought that he was helping to do the right thing, namely, helping with an elopement.

The young men were let off with community service, but the damage was already done. Eyüp, Yâsin's elder brother who helped with the abduction, had to receive psychiatric treatment. The accusations of his parents, that he, as the eldest son, was primarily responsible for the failure of the abduction, were too great a burden. Yâsin did not fare much better. He had truly believed that Heleen would stay with him, but she broke off their relationship after the abduction. This was such a blow for Yâsin that he attempted suicide. His life was saved in a hospital.

In this case, it could have been clear from the outset that it was an abduction; not because Türkay said so (quite correctly, her story was not immediately believed; back with her parents, she had no choice

but to say that she was abducted), but from the way it happened. If Türkay had wanted to stage an abduction to demonstrate to her parents that she was a respectable girl, she and Yâsin would not have done so in such a risky manner. She would simply not have come home from school and – once safe with her boyfriend – would have let her parents know that she had been abducted.

That is what happened in an incident in Rotterdam. An 18-year-old Turkish girl, who had been abducted six days earlier, was liberated from a house by the police. She had informed her parents that she had been abducted by an illegal immigrant and that she had to marry him. It later emerged that the girl had invented the abduction for fear of her family. She had gone to the man, her boyfriend, of her own free will and they were married that same day in an *imam* ceremony.²³

For the girl, it matters very much – following a failed elopement – whether she is seen as the guilty party who tried to run away from home, or the innocent victim of an abduction. In the first instance, she is *namussuz* and everything hinges on how accommodating her parents are; in the second instance, she is *namusu kirlenmiş* (there is a stain upon her) but she can usually return home again. This is in contrast to what the girl herself thinks (namely that she has no option other than to marry the boy). In the case of abduction, however, it must be clear that the girl had absolutely no part in it. If there is even the slightest doubt, she becomes *namussuz*.

That is what happened in the Sefiye case study mentioned above. Playing truant from school, Sefiye sat drinking tea with a Turkish boyfriend. Ahmet, who was also present, then abducted her. Sefiye felt guilty about the abduction because she had provoked it through her ‘bad behaviour’. Her father also believed that she was guilty, but attributed this to the fact that she had lived in the Netherlands for eleven years, which had undermined her moral standards. He was certain that, had she conducted herself as a typical Turkish girl should, it would never have happened.²⁴ The father found her behaviour unacceptable, but by interpreting it in a way that he could comprehend, he was able to receive her back into his home.

Similar compromises occur with regard to elopements in which daughters willingly participate. The elopement is presented as an abduction so that the daughter will not appear *namussuz* (dishonourable). However, this only works if the girl has a spotless name. If she has a reputation for hanging around with boys, people will not

readily believe the abduction story and the family will continue to be plagued by gossip.

We see the role of gossip in the case of Asiye. Although she was abducted against her will, the abductor's family began to slander her name. They claimed that Asiye was a whore, that her father should have kept better watch over his daughter, and that Asiye must have provoked the abduction. They questioned why her father would not let his daughter marry the abductor. Asiye's father was almost too ashamed to show his face in public. To escape the gossip, he decided to sell their house and move elsewhere. Until the move took place, Asiye went with her mother to Turkey.²⁵

The abduction or elopement of a daughter means loss of *namus* for a family. This loss can be counteracted by having the daughter marry the young man in question. Alongside loss of *namus*, there is also loss of *şeref*, wounded pride. A father wants to keep his daughter at home so that he can give her away on her wedding day. Her brother ties a red ribbon around her waist to symbolise her virginity. The wedding day bestows *şeref* on the father: his daughter has not run away and he has succeeded in protecting her from strangers. For the mother too, it is a day on which to be proud, as it is her task to bring her daughter up properly. The prospective in-laws should be grateful to the girl's parents for such a fine bride.

If the daughter arranges her marriage herself or is abducted, there is loss of *şeref*. The family then has a daughter who shows no *saygı* (respect, deference) or has not been properly protected by her father and brothers. I am not aware whether, in general, mothers and fathers differ in their responses to an elopement. I suspect that it is worse for the father because, officially at least, his daughter has been abducted and he has failed to protect her. A father's reaction to an elopement reveals the extent to which it affects him. Yerden cites the example of a girl who ran away from home but regretted it eight hours later. She said: "When I came home, everyone was in mourning. My father embraced me and then fainted."²⁶ In the Tekin case, the father immediately gave up everything to go in search of his daughter. He even stopped going to work, and did not rest until he found her.

There are a number of ways in which the girl's father can alleviate the loss of *şeref* that he suffers when his daughter elopes and marries. Firstly, by making no reference to the elopement after the wedding. The elopement in effect becomes a taboo subject. Because any reminder is painful to the father and is an infringement upon his *şeref*,

other men, particularly the daughter's father-in-law, will help the girl's father by keeping silent on the subject. Similarly, the husband does not mention it out of respect for his father-in-law. Women appear to be more forthcoming on the subject of elopements.²⁷

Secondly, for a period following the elopement, the father may be *küs* toward his daughter and her husband; in other words, he avoids all contact with them. If he meets them by accident, he acts as though they do not exist. He expects his wife to exhibit the same behaviour. She does not always do so, but this does not matter, provided it is not done openly. This state of affairs usually persists until the first grandchild is born.²⁸

Thirdly, the girl's father may demand a very high bride-price (*başlık parası*) as compensation for his injured *şeref*.²⁹ In the Şener case study, for instance, the father initially asked as much as 40,000 guilders. *Başlık parası* (usually abbreviated as *başlık*) is the sum of money that the father of the groom pays to the father of the bride when their children marry.³⁰ A bride-price is a tradition in many parts of Turkey. The young man's family does not have to agree to the *başlık*, as they already have the girl in their possession. Nevertheless, they will want to comply with the request of the girl's father so that the husband can enjoy a good relationship with his father-in-law. An elopement is only inexpensive if both sets of parents urge their children to elope in order to spare themselves the cost of a wedding. If the elopement takes place without the knowledge of the girl's father, he will not be prepared to make things easy for the boy and his father.³¹

Fourthly, out of respect for the male members of the girl's family, there is no wedding celebration following an elopement. Instead, the marriage is held in private. In some parts of western Turkey, however, elopements have become so commonplace that a wedding celebration does take place. In such a case, the male members of the bride's family do not attend, only the womenfolk, or everyone puts in a very brief appearance.³²

Fifthly, the girl's father may decide not to give his daughter a trousseau (*çeyiz*).³³ Sometimes, anticipating this, the girl takes part of her trousseau with her when she elopes. Loss of the *çeyiz*, which the girl has stitched at and toiled over from a very young age, is a serious matter. The *çeyiz* often contains a full range of household goods as well, such as blankets (*yorgan*), mattresses and electrical appliances.

Sixthly, the father may take the young man to court for abducting his daughter. This kind of court case usually ends in a marriage be-

tween the young man and the girl, with the young man being let off from a prison sentence. Newspapers then report 'a happy ending' (*mutlu son*). One may wonder why a court case is necessary. Surely the couple could simply have married straight away? A court case is often a means by which the father demonstrates his authority. It teaches the young man that his father-in-law is not to be trifled with. Moreover, the husband may not divorce the girl within three years; if he does, he will have to serve his prison sentence after all. However, not all fathers take matters as far as a court case. While the case is in progress, the girl remains unmarried, and her *namus* and that of her family remains tarnished. A court case also attracts more publicity, thus drawing attention to the elopement, which adds further to the father's loss of *şeref*.³⁴

These are ways in which a father can limit the loss of *şeref* resulting from his daughter's elopement, while at the same time allowing the marriage to proceed. If, however, he really opposes the marriage, there are a number of alternatives open to him, some of them rather drastic, without the need to resort to an honour killing. The chief alternative, disowning his daughter, I will discuss in chapter six.³⁵

4.3. Honour killing following an elopement

THE TEKIN CASE STUDY: 'THE DISC JOCKEY' (1989)

The Tekins, a Turkish family living in the Netherlands, have four children: a son, Ekrem, who is married; a daughter, Hanife (aged 19); a daughter Pınar (aged 17); and a son, Serhat (aged 11). Mr. Tekin owns a great deal of land in his native village and has the title of 'hacı', which means he has made the pilgrimage to Mecca. Pınar is engaged to a cousin, whom she will marry in August 1989. The previous winter, Pınar spends a lot of time listening to a local, Turkish pirate radio station and falls in love with Halil, the disc jockey. In July 1989, Pınar's mother and sister, Hanife, notice that Pınar is receiving many phone calls and that there are an unusual number of 'wrong numbers'. One evening when the phone rings, Hanife pretends to be Pınar and in this way finds out that the man on the phone is her sister's boyfriend. She immediately tells her mother. Neither of them can make a scene as they have visitors. Pınar, who realises what has gone wrong, slips out of the house. Her mother and sister do not discover her absence until the visitors have gone. As soon as Tekin comes home, all acquaintances and relatives in

the Netherlands are phoned or visited in an attempt to discover Pınar's whereabouts. A girlfriend, who says she might know where Pınar is, gives Halil's phone number to Tekin.

Armed with this information, Tekin goes to the police station to report his daughter as missing. He is accompanied by his daughter, Hanife, who acts as an interpreter. Police officer Vermaas (not his real name) accompanies Tekin to Halil's house, but there is nobody home. Vermaas promises Tekin that he will look into the matter. It turns out that Pınar was in fact with Halil. When she went to Halil that evening, the two of them immediately sought refuge at the house of a friend of Halil's. Vermaas asks Pınar to ring her father the next day at an appointed time, and she agrees. However, when she phones her father, she immediately asks for her papers (probably her passport and residence permit, which she needs for a civil marriage). This strikes the wrong chord with Tekin, who becomes angry. The call is broken off (it is not clear by whom). Two conversations take place between Tekin and Abdul Gök, the man with whom Halil and Pınar are staying. Tekin makes it absolutely clear that he wants his daughter back.

Two weeks later, the couple decide to return to Halil's flat. That same day, they go to the Registry Office to give notice of their intended marriage, but are unable to do so because they do not have the necessary documents. Pınar and Halil are then married by an Islamic cleric in an imam ceremony. Tekin hears about this but tells police officer Vermaas that it means nothing to him and that he still wants his daughter back. The following day, Vermaas goes on holiday. Tekin appoints Yılmaz Işık as mediator. Yılmaz arranges for Pınar to speak into a tape recorder. She says that she is with Halil of her own free will and wants to marry him. Yılmaz plans to give the tape to Tekin, but he cannot do so immediately because he has to work the night shift. Two hours after Yılmaz has left, Tekin arrives at the door of Halil's flat. Tekin has been there several times previously but has never found anyone home until now. This evening, he is able to go right to the front door as the door to the stairwell has been left open. The front door is closed and on the latch.

In Pınar's words: "To begin with, my father's manner was friendly. He said: "Open the door, Pınar. I won't do anything." [...] Halil told me to hide in the kitchen. We kept quiet. My father got more and more angry. Halil called the police and told them my father was at the door. When my father got even angrier, Halil rang the police once more. By then, he was in a state of panic. While Halil was still on the phone, my father managed to batter the door down. The door flew open and my father stepped inside. He passed by without seeing me. He was holding something silver in his hand. Father went up to Halil [...]. I saw Halil quickly running through the living room as though fleeing from my father. Father ran after him. Halil ran into the bed-

room [...]. I rushed out of the house to fetch help. I heard Halil call out my name several times. I fell in the stairwell. The neighbours came to look and I shouted that my father was stabbing my husband to death.'

Halil died as a result of stabs to his chest, which perforated his heart and his lungs.

For Tekin, marriage following the elopement was simply out of the question. He believed that Halil had no honourable intentions regarding Pınar. He had discovered that Halil was living illegally in the Netherlands and believed that he only wanted to marry his daughter in order to get his hands on a residence permit. This suspicion was reinforced when he learned that Halil was significantly older than Pınar (Halil was 30 and Pınar just 17), and that he had a wife and three children in Turkey.

This is not an isolated case. Although the Netherlands is popular among underprivileged Turks in Turkey, there are limited opportunities for building a future here legally. One way to acquire a residence permit is to marry a Turkish girl who lives in the Netherlands. There are other examples of elopements that may have been motivated by the desire to obtain a residence permit. In the 'Elif' case study from the *Hürriyet*, Elif, a Turkish girl living in Germany, was abducted while on holiday in Turkey. For Faruk, the young man involved, Elif was probably an attractive proposition because marriage to her would enable him to enter Germany. In the Sefiye case study, we know this to be the motivation. The young man, Ahmet, who was living illegally in the Netherlands, wished to acquire a residence permit through marriage. In the Asiye case study too, it was a boy without legal status who carried out the abduction. The girl in Rotterdam who eloped, telling her parents that she was abducted, probably mentioned that the boy was living here illegally because this would lend greater credibility to her abduction claim.

Tekin believed that his daughter regretted the elopement but did not dare return home because her *namus* was sullied. She had accepted that Halil was her husband (as revealed by her words in the stairwell: 'my father is killing my husband'). Tekin could not comprehend the elopement because Pınar had been looking forward to marrying her cousin, which was due to take place the following month. She had never shown any opposition to the coming marriage. On the contrary, on the day she ran away, she had asked her father for a camera as a wedding present, and the day before, she had ordered shoes for her fiancé in Turkey. Her 25-year-old brother,

Ekrem, told the same story: 'For two years, Pınar has worked with great patience and enthusiasm on her trousseau. She embroidered her future husband's name onto sheets and pillows and wrote him long letters. Together with my father, she bought new furniture for her future house and she wanted my father to exchange his old car for a much better one so that he could arrive at the wedding in style. All in all, it cost my father 15,000 guilders, which he was quite happy to spend because Pınar was the apple of his eye.'

After speaking to police officer Vermaas, it seems to me that the two reasons put forward by Tekin seem highly plausible. Through his contacts in the Turkish community, Vermaas was able to tell me more about Halil. He believed that Halil's sole purpose in setting up the pirate radio station was to come into contact with Turkish girls. His objective was to get his hands on a Turkish girl living in the Netherlands and in this way obtain a residence permit. According to Vermaas, Pınar was no more than a means to an end. Vermaas said that the members of Halil's family who lived in the Netherlands were at a loss as to what to do about him. They did not want to mediate in the elopement because they felt that Halil should have stayed in Turkey with his wife and children.

We can understand how 17-year-old Pınar was lured into Halil's trap when we read the police officer's description of her: 'A young, naïve, lively and impulsive type, unable to see the broader picture, and completely spoiled by her father.' According to Vermaas, Pınar responded to Halil's advances out of a desire for adventure. She found it exciting to receive his phone calls; she barely knew him. She had probably been so enthusiastic about her wedding in Turkey for the same reason. Vermaas did not believe that she was in love with her cousin (she barely knew him either), but the idea of being the centre of attention at a celebration really appealed to her.

What Vermaas could not explain at the time or during my interview with him, but what adds to Tekin's credibility as to his motives, was Pınar's conduct at the crisis centre where the police took her after Halil's death. The police were not certain whether it was safe for Pınar at home. Her father and brother had spoken of her in a threatening way. Vermaas said: "She was cheerful, she put on make-up, she went out in the evenings, and she wore short skirts. She caused problems for the other girls in the centre because it was supposed to be a secret address. I can't understand this behaviour. You would think she'd be very sad. After all, her boyfriend had just been killed!"

In light of Vermaas' description, however, it seems to me that Pınar ran off to Halil without thinking when she realised that her mother and sister had found out about her relationship, and that, once there, she regretted it. She did not dare go home because it was obvious that the elopement was her own idea. Halil's death would therefore have been a release for her. Once at the crisis centre, where members of her family had no control over her, she perhaps decided to make the most of it: such an opportunity would never come again.

Tekin told the court that he never intended to kill Halil. At the police station, and in court, he expressed regret for his deed. The court decided on the basis of a psychiatric report that Tekin had acted in a state of diminished responsibility at the time of the stabbing. The court eventually came down with a mild sentence of 5 years imprisonment for manslaughter. There was no appeal.

Vermaas told me that he had heard about the honour killing when he returned from his holiday, and that he went to visit Tekin at the remand centre. Vermaas said to me: "I don't believe for one moment that he was sorry. He didn't say as much, it's true, but it was clear from the way he sat there. His eyes were gleaming. I'm convinced that he knew exactly what he was doing. Tekin was a huge man and Halil was no match for him. He killed him like a dog." This statement is completely at odds with the information in the court records, from which Tekin emerges as being full of remorse and most unhappy about Halil's death.

4.4. The girl is killed

In honour killings that follow an elopement, it is not always the boy who is the victim. Sometimes the girl is killed by members of her family, as happened in the honour killings of Elmas and Ardal.

THE ELMAS CASE STUDY: 'THE DUTCH BOYFRIEND' (1978)

Elmas leaves for the Netherlands in 1963, and his wife follows in 1972. Their three children, all sons, move in with their paternal grandparents. A year later, Mrs. Elmas gives birth to their fourth child, a girl. In that same year, 1973, Elmas arranges for the daughter from his first marriage to be brought over to the Netherlands. Her name is Ayşe and she is fourteen years old. Her father probably brought her over so that she could look after the baby and al-

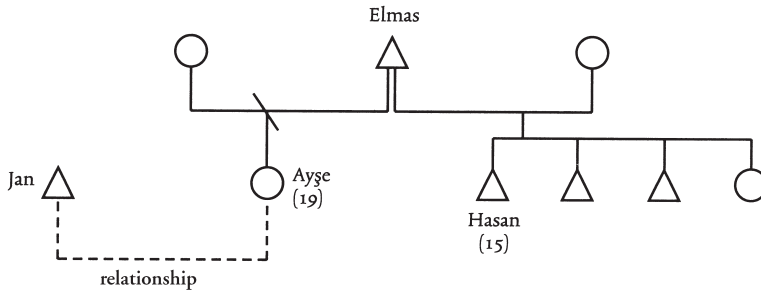

Fig. 6: The Elmas case study

low his wife to continue working; they are trying to save all they can for a return to Turkey. Ayşe probably does not attend school (we do not know this for certain as there is no information about her in the court records). In 1974, Mrs. Elmas goes back to Turkey in connection with the schooling of Hasan, the eldest son. Because there is no secondary school in the grandparents' village, Mrs. Elmas goes to live with her children in the district capital. Ayşe stays behind with her father in the Netherlands and goes to work in a factory. To make this officially possible, her date of birth in Turkey is changed to make her appear three years older.

In the summer of 1978, Elmas goes to Turkey to collect his wife and children. Ayşe stays in the Netherlands because of her work. Hasan, now aged 15, attends a junior technical school in the Netherlands. In September 1978, he informs his father that his half-sister Ayşe has a Dutch boyfriend. Elmas does not believe it at first, but when he talks to Ayşe she admits that it is true. She has known Jan for fourteen months. They both work in the same factory, where he is a quality controller and she a packer. Elmas forbids his daughter to have any further contact with Jan. He writes to the parents of her fiancé in Turkey, saying that the wedding should take place as soon as possible. He plans to fly to Turkey with Ayşe that same month. However, the trip does not go ahead because Ayşe tries to drown herself. Shortly beforehand, she rings Jan and tells him that she will kill herself at the spot where they first met. Jan is able to rescue her just in time. Elmas meets Jan for the first time at the hospital to which Ayşe has been admitted. Elmas is friendly toward him.

Ayşe wrote her father a suicide note, which she left at home: 'I do not want to marry the person I have made my promises to. May he forgive me for that [...]. I have no regrets that I have loved a Dutchman. As I die, I declare still that I love him. I have had enough of you, ever since I was a child [...]. I

have always done my best to help my family. They have turned their back on me. She has gone. Farewell.'

Jan explains what happened next: 'Everything seemed to be fine again between Ayşe and her family. The police were working to this end as well. Nothing seemed to stand in the way of our marriage.' But at the end of September, Ayşe jumps out of a first-floor window of her parent's upstairs flat when her father pursues her with a knife. She seeks refuge at a neighbour's house. There she phones Jan, who still lives with his parents, and he comes to fetch her. She moves in with Jan and his parents because she doesn't dare return home. A sprained ankle is all she retains from the jump.

Elmas does not see Ayşe for two weeks. He goes to the factory where she works but she is too afraid to appear. Elmas has several conversations with Jan. Jan's parents call in the police to mediate. Elmas is very accommodating toward the police and says he will cooperate about a wedding. At the same time, however, he sends a compatriot to Jan's house to persuade Ayşe to come home. Ayşe refuses. Ayşe is then phoned by a Turkish girl, who tells her that her father has bought a pistol in Belgium and plans to kill her.

Jan invites Elmas several times to come and visit them but he never does. At the end of October, Elmas changes his mind and comes with his whole family. According to Elmas: 'I spoke at great length with Jan and his parents and with Ayşe. I was happy for them to marry and we agreed that the wedding would take place in December. Jan's mother showed us the house and his father invited me to play billiards with him. After that, I phoned Ayşe every day to ask how she was.' Jan says about the visit: 'Elmas said then that he no longer objected to the marriage. He just said that he had to go to Turkey to discuss it with his family. I then told Elmas that I didn't need his permission and that we'd already been to the Turkish Consulate to get the necessary papers for Ayşe.'

A week later, Jan and Ayşe visit the Elmas family at their home. Jan says about this visit: 'Elmas behaved quite well towards me but he really carried on at Ayşe, at least that's what I could pick up from the way he spoke.' Elmas says of Jan's visit to his house: 'We spoke about the wedding. I told Jan about the fundamentals of Islam and that he had to become a Muslim. He was prepared to do that [...]. I told him, in accordance with Islam, a man had to pray to Allah [...] five times a day and that he had to behave decently and honestly to everyone. I, myself, am a pious Muslim who observes the rules.' Elmas tells them that evening that he will leave for Turkey the following week.

When the time comes, Jan and Ayşe take Elmas to Schiphol Airport. Ayşe's brother, Hasan, goes as well. Later, Elmas tells the police the following about his trip to Turkey: 'I went to Turkey for the Festival of Sacrifice. I wanted to let my family know at once that Ayşe was going to marry Jan.' At

the airport, Elmas tells Ayşe that Hasan will give her back her gold bracelet. Ayşe had always wanted it back but her parents had refused until now.

Jan, Ayşe and Hasan return to the house of Ayşe's parents. Jan explains what happened there: "Hasan opened various drawers and cupboards. Looking back, I realise that this was just for appearances' sake. Hasan wasn't really looking for the bracelet. I had a strange feeling. And their mother kept pacing up and down. We eventually left. Hasan accompanied us downstairs to let us out. I got into my car. At that point Ayşe and her brother were standing on the other side of the car. I heard a sudden bang. I got out of the car and saw Hasan pointing the gun at Ayşe. He pulled the trigger twice. Ayşe was already lying on the ground. The gun didn't go off [...]. I ran at Hasan and knocked him to the ground. We fought. I let Hasan go and grabbed Ayşe and put her in my car. I drove to the hospital. Ayşe was already showing no signs of life.'

When the police go in search of Hasan, they find him just sitting at home. In the first police interview that same day, the 15-year-old Hasan says: 'I killed my sister this evening. I did it for many reasons. I did it for the sake of my family's honour. My sister was living with Jan without being married. The family cannot tolerate that.' The following day Jan and Ayşe were to have given notice of their intended marriage. Hasan Elmas was sentenced to six months in borstal for murder.

The father told the police that he knew nothing of the honour killing and that he in no way supported it. He said that he had already given his permission for the wedding and simply wanted to go to Turkey to discuss it with his brothers and sisters. His trip to Turkey was probably intended to shift the full responsibility for the killing onto his son and to ensure that he himself had a good alibi. Jan, who drove him to the airport, told the police that he was surprised that Elmas, who was supposedly going for two weeks, only had hand luggage. This might suggest that Elmas knew he would be back in the Netherlands in a few days (in connection with his daughter's death).

Elmas' friendliness is another element that gives rise to suspicion in this case study. We have seen that a girl's father usually reacts awkwardly to an elopement, even if he accepts the ensuing marriage. He does not talk to his daughter for a time, demands a hefty bride-price, or shows his displeasure in some other way. In the Elmas case, the father was completely opposed to the elopement, but he was very accommodating in his behaviour: he called on Jan and his family, invited Jan to his home, stated publicly that he was very happy about the planned marriage, and even let Jan drive him to the airport. His

daughter was suspicious of his friendly behaviour. Jan said that Ayşe had constantly warned him not to trust her father's friendly words. However, Jan and his parents – as Dutch people – believed that everything was fine, and Ayşe herself lowered her guard.

The Ardal case study is a comparable one. Here too it seems that the girl's family only made a pretence of agreeing to the marriage.

THE ARDAL CASE STUDY: 'THE ALAWITE BOYFRIEND' (1991)

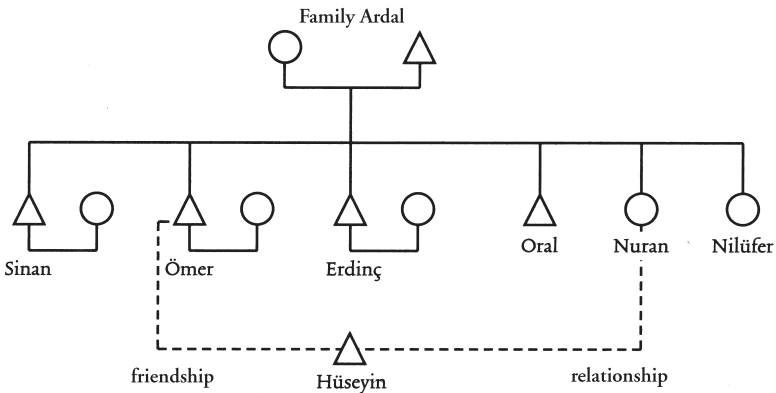

Fig. 7: The Ardal case study

Nuran Ardal comes from a Sunnite Turkish family with six children. Three older brothers are already married. The father is a devout Muslim, who is very knowledgeable about the teachings of Islam. He has instructed all of his children on the Koran and they know it by heart. Nuran tells her sister, Nilüfer, that she is in love with Hüseyin, the Alawite friend of Ömer, her second to eldest brother. Two weeks after her eighteenth birthday, Nuran does not come home from work. She calls the wife of her third brother, Erdinç, to say that she is at a reception centre. In reality, she has moved in with her boyfriend, Hüseyin.

A week later, two mediators visit Nuran's parents to talk things over. They say that Nuran has gone of her own free will and that she would like to marry Hüseyin. That same day, Nuran and Hüseyin try to give notice of their intended marriage at the consulate. This fails because Nuran's fourth brother, Oral, is at the consulate at the time. Two days later, the mediators return to the Ardal family. They have been in contact again with Hüseyin

and his family, and they propose that the couple give notice of their marriage. Nuran's parents agree, provided that Nuran returns to her parents' home before the wedding, which cannot be held until Ramadan, the fasting month, is over.³⁶

Notice of the intended marriage is given at the Turkish Consulate, with Nuran's parents and brothers present, as well as Hüseyin's father and sister and several other members of Hüseyin's family. Afterwards, they share a reconciliation meal at the home of Nuran's parents. Both mediators are present as well. Conspicuous by his absence at both the ceremony and the meal is Nuran's brother, Ömer. When the meal is over, Hüseyin's family leaves, and Nuran stays behind, as arranged, in her parents' house.

That day, Nuran is home alone with Sinan, her eldest brother. Sinan questions Nuran, asking her whether she is not ashamed to have discredited her family by her behaviour. He also tells her that he does not think Hüseyin is a suitable husband for her. Nuran replies that she does not agree with him and that he should mind his own business. Sinan is incensed by this response, which he regards as inappropriate. He tells Nuran angrily that she should return all the pocket money that he has given her over the years. Nuran makes a venomous reply, and Sinan, to use his own words, loses his self-control and calls her a whore. Nuran responds by spitting in Sinan's face. Sinan says later that he was beside himself and that he strangled Nuran.

Hüseyin maintained that the family collectively decided to kill Nuran and that Sinan should carry out the killing. Because he had a doctor's certificate declaring that he was mentally unstable, he would be given a light sentence. Was there a family plot? We should look at the following considerations. No firearm was used, which might suggest that there was no advanced planning. On the other hand, there may have been deliberate reasons for not using a firearm. The honour killing had to appear 'unplanned' to ensure the lightest possible sentence for Sinan. We must not forget that this case study involves an adult honour killer who could expect a tough prison sentence. Perhaps another reason for not using a firearm is that it is not considered an appropriate weapon for killing a woman. Durham reports that devout Muslims (a group to which the Ardal family belonged) believe that a dishonourable woman should be stoned to death rather than shot.³⁷ Kressel points out that there are more and less honourable ways of committing an honour killing: shooting is the most honourable, and strangling less so. Women tend to be killed in less honourable ways.³⁸

Both families were present at the ceremony where notification was given of the marriage, and afterwards they were together for the reconciliation meal. If there were a family plot, this would have been very treacherous indeed. However, we have learned from the Elmas case study that such a thing is possible. In the Ardal case, the usual rituals whereby the girl's father displays anger about his daughter's elopement were not followed, which makes the subsequent extreme rapprochement suspect. Nuran's brother Ömer was notably absent from the reconciliation meal, and Nuran was afraid that he did not approve of her forthcoming marriage. It is also possible that Ömer stayed away because he knew that the reconciliation was a 'fake' and he did not agree with this. As a good friend of Hüseyin, he was probably not opposed to the marriage. The police were unable to find a shred of evidence to support a conspiracy theory, which is not to say that no such conspiracy existed. After all, the whole point is to leave no evidence. Moreover, the murderer must appear to have acted entirely alone. Sinan Ardal was sentenced to six years' imprisonment for manslaughter.

It is not uncommon for women and girls to be lured home on the pretext of a reconciliation (*barış*). In the 'Stoning in the market square' case study, in which the girl disposed of her newborn baby in a wheatfield, her brother acted as though the family wished to be reconciled with her. He picked her up from the place where she had sought refuge, but as soon as they reached the market square, he killed her. An article in the *Hürriyet* tells the story of the married couple, Fadime and Hasan Çelikkıran, from Adana. Fadime left her husband to go and live with her lover. Her husband lured Fadime and her lover home with the promise that they would arrange for a divorce. As soon as they reached the house, he killed them both.³⁹

5. More case studies

5.1. Authority over the children

THE TÜRKMEN CASE STUDY: 'ON A MISSION TO THE NETHERLANDS'
(1990)¹

The Kaya family lived in the Netherlands for years before settling in a town in Central Anatolia in 1986. There, Kaya opens up a lunchroom with Gitmez, his business partner. Kaya often returns to the Netherlands on business. During his absence, a relationship develops between his partner and his wife, Emine. This cannot remain a secret for long in such a small town and rumours begin to circulate. Kaya eventually comes to hear of it as well. In 1987, he decides to return to the Netherlands with his wife and children and to hand over the lunchroom to Gitmez. However, Gitmez leaves his wife in Turkey and departs for the Netherlands that same year. Emine leaves her husband and children and goes to Gitmez. They live together at a secret address in the Netherlands. Kaya repudiates his wife and soon marries a widow from Istanbul, where he stays with his children for all of 1988.

In 1989, he returns to the Netherlands with his new wife and his two children, now seven and nine years old. When the family has been in the Netherlands for six weeks, Emine abducts her children from school. Kaya immediately initiates legal proceedings to get his children back. Later that year, the case comes before the juvenile court, where the magistrate awards the mother provisional custody of the children. The final decision about custody will be taken in 1990. The day of the hearing, Emine travels by train from her home to the town where the hearing is to take place. When she gets there, Sedat Türkmen, her 21-year-old brother, shoots and kills her in broad daylight, in front of many witnesses. She is 29 years old.

Sedat Türkmen claimed that the decision to kill Emine was taken in mid-1988, and that his blood relatives had appointed him to carry out the honour killing. The expert witness was most surprised that Sedat Türkmen was able to postpone the honour killing for so long: 'Normally, once a decision is taken, the honour killing takes place

shortly afterwards', and he was at a loss as to how to explain the incident.

I believe, however, that the explanation lies in the fact that the honour-killing decision was not taken at that time. Kaya had been content to repudiate his wife when she left him. However, she then abducted the children (who had stayed with Kaya), and raised them together with her boyfriend, Gitmez. Kaya tried and failed to gain custody of the children through the courts. It was probably not until that point that the question of an honour killing arose. For Kaya to gain custody over the children, their mother had to die. Kaya was probably not prepared to wait until the final hearing because he no longer held out any hopes of getting the children back and he was afraid that Emine, her boyfriend and the children would disappear after the hearing. Reabducting the children was not an option for him because this would then mean taking them into hiding in Turkey. Kaya could not commit the honour killing himself because he would then have to serve a prison sentence, with all its attendant consequences: loss of work and the risk of deportation to Turkey. Moreover, there was the consideration that he would not be granted custody if he committed the killing.

My theory is that Kaya enlisted the support of his ex-wife's blood relatives. Sedat Türkmen, Emine's unmarried and unemployed brother, would do the honour killing and ensure that Kaya was kept out of it. This helps explain why Sedat Türkmen claimed that the decision to commit an honour killing had been made so long ago. If he had said that the decision was taken at the time when the mother was awarded provisional custody of the children, the finger of suspicion would then have pointed to Kaya. Sedat had another reason for dating the decision so early, one that relates to his personal motives for committing the honour killing.

Why would Sedat Türkmen take the honour killing upon himself? At first glance, it appears that he sacrificed himself for family honour and for his brother-in-law. Sedat Türkmen claimed that he had had great difficulties with the obligation to kill his sister, which was why he began drinking. According to Sedat: 'I drank for about a year and a half. Alcohol was my only friend. I felt really oppressed by the pressure I felt inside. I drank because I didn't know what to do: how should I do it? How would I find them?' The probation officer wrote the following about Sedat's drinking: 'Sedat says that he started drinking in mid-1988. Every day he would drink as much beer, and gin and tonic as he could. In the period 1988-1989, Sedat

had to be treated three times at the outpatients' clinic after drinking himself into a coma. Once his stomach had been pumped, he was able to return home. On one occasion, he even considered taking his own life. He wanted to hide his alcohol consumption from his family, but this was not possible because he lived with one of his older brothers. His excessive drinking was not appreciated, and he lost his family's esteem. Sedat claims that his drinking resulted solely from the problems with his sister. When drinking, he would fantasise about how he would kill his sister and her boyfriend.'

The probation officer believes that his sister's behaviour had nothing to do with Sedat's drinking: 'The general picture we have is of a young man who is a failure [...]. He himself admits that he has not "led a good life" until now [...]. Totally unprepared, he was left in a big city like Istanbul with a brother who was to all intents and purposes a stranger to him [...].' Sedat Türkmen had lived with his parents in a village in Central Anatolia until he was twelve years old. He then left to go and live with his older brothers in Istanbul, where there were better educational prospects. But he had problems adjusting to the big city and felt an outsider at school. He left school without any qualifications and simply hung about, refusing to accept menial jobs.

The probation officer ended his report with the comment: 'We cannot rule out the possibility that Sedat became trapped by his situation and started drinking excessively. Perhaps Sedat saw the problems relating to his sister as a means of regaining his position within the family.' The psychiatrist also concluded that Sedat Türkmen used the honour killing to recover his lost status: 'In my opinion, he hoped to win his family's esteem with this stratagem [...]. There is clearly more at issue here than blood revenge alone.'²

Thus, over and above the cleansing of *namus*, both the accomplice and the honour killer in this case study had an additional motive for the honour killing. The former wanted his children back, and the latter wished to win back his lost *şeref*. The honour killer did not obediently follow instructions or sacrifice himself for the sake of family honour alone.

5.2. Incitement to murder

THE UZUN CASE STUDY: 'THE BOARDED-UP HOUSE' (1978)

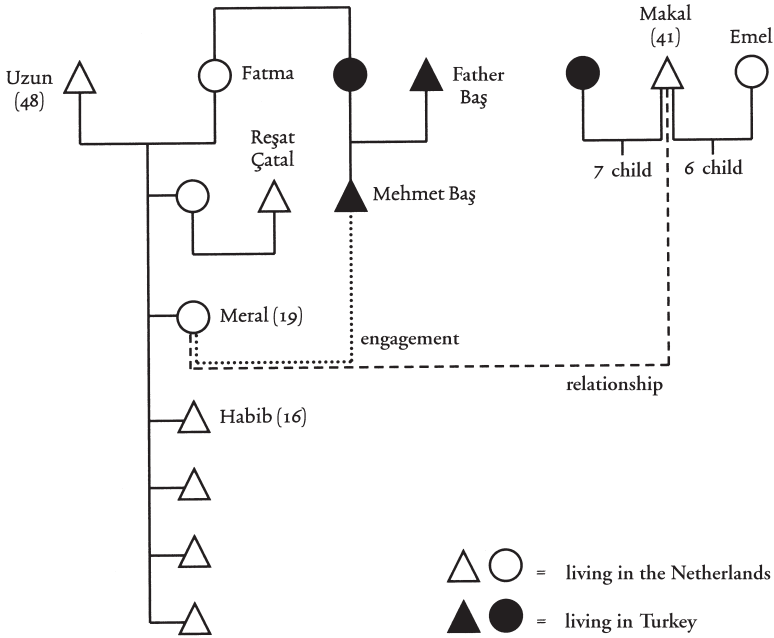

Fig. 8: The Uzun case study

In 1966, at the age of thirty-six, Uzun moves to the Netherlands from a village in the Black Sea region of Turkey. His wife Fatma and their six children follow in 1972. They are followed by many others from the same region, including the Özkök and Fakir families, with whom the Uzuns have close contact. In the Netherlands, Uzun becomes acquainted with his compatriot Makal, who is seven years younger and married to Emel. Emel Makal and Fatma Uzun both work in a chicken slaughterhouse. The Uzun and Makal families call on one another regularly, several times a week. Emel is Makal's second wife. His first wife, to whom he is still officially married, lives in Turkey with their seven children.³

In 1978, Meral Uzun, the 19-year-old daughter of the Uzuns, begins a relationship with Makal, who is then 41 years old. Makal ferries Turkish women and girls by van to and from a nearby town where they work in a fac-

tory. Meral is always the last one in the bus on the return trip. About twice a month, Makal drives with her into the woods where they make love. Meral tells the police later that the women in the van know that she is having a relationship with Makal.

That summer, Mr. and Mrs. Uzun go on holiday to Turkey with their third child, the 16-year-old Habib. Meral and the three youngest children stay with the Uzun's eldest daughter, who is married to Reşat Çatal and who lives in the same town. The plan is for the Uzuns to take Mehmet Başı, the 'teyze oğlu' (son of a sister of Mrs. Uzun), back with them on the return journey from Turkey to Germany, where he will stay with relatives until the imam ceremony and the wedding to Meral, scheduled to take place in September. Meral and Mehmet have already been married in a civil ceremony so that Mehmet could obtain a visa. This ceremony was seen as a mere formality, and was not followed by the wedding night.

Just ten days after the Uzuns' departure for Turkey, son-in-law Reşat writes to them advising them to return as quickly as possible because he has discovered that Meral is having a relationship with Makal. He tells them to leave Mehmet Başı in Turkey to avoid unnecessary expenditure. Mr. and Mrs. Uzun do not believe the story and decide to take Mehmet with them anyway. They leave him with relatives in Germany. Once in the Netherlands, Mrs. Uzun questions Meral, who denies that she is having an affair with Makal. One of Uzun's brothers visits and tells them they should take Meral to a doctor to see whether she is still a virgin. The son, Habib, is aware that Meral is listening in on the conversation.

The following day, Habib and Mrs. Uzun go to work. Habib works with his mother at the slaughterhouse. His date of birth had been altered in Turkey to make him appear eighteen, instead of his actual sixteen, so that he could work full-time. When Habib returns home at about half past ten in the evening, Meral is not there. She has told a younger brother that she has gone to see the Fakir family, friends of the Uzuns. Habib goes at once but Meral is not there either. "I immediately suspected that she had run away," Habib said later. Habib is afraid that Makal, who is holidaying in Turkey with his second wife, will come to pick up Meral and take her back to Turkey with him. Habib goes to his father, who is working the night shift. That same night, they go to various homes in search of Meral. The following morning, Habib's suspicions are confirmed. The Uzun family receives a disquieting telegram from Makal's second wife in Turkey. She writes that her husband is travelling to the Netherlands to fetch Meral and take her back to Turkey. She ends the telegram with the plea, 'Keep a close watch on your daughter... I don't want my marriage to be ruined.'

Uzun also receives an angry letter from the father of Mehmet Baş, Meral's fiancé, accusing Uzun of not properly safeguarding his prospective daughter-in-law's virtue. It is a fortnight before the Uzuns receive word of their daughter Meral. A telegram arrives from Makal's parents, informing them that Meral is staying in Istanbul with the family of their son-in-law, Reşat Çatal.

This is what had happened. When Reşat Çatal discovered the relationship between Meral and Makal, Meral wrote to Makal threatening that she would commit suicide if he did not come and collect her. Makal came to the Netherlands and took her back to Turkey, hidden in his car. When they arrived at the home of Makal's relatives, the father of Makal's second wife objected, accusing him of improper conduct. He already had two wives, what did he want with a third one? Makal's second wife later said: 'My husband arrived with Meral. I didn't want the girl. My husband cried. He said that the whole thing had been Meral's idea. She had threatened to commit suicide and he therefore felt obliged to fetch her. My husband proposed living with both me and Meral, which I didn't want.' Makal's father-in-law then took Meral to Istanbul.

Makal, his second wife and their children do not return to the Netherlands until autumn. They do not dare go back to their own house. They have heard from a Turkish friend, Nejat, who lives across the road, that their house has been nailed shut, apparently the work of the Fakirs and the Uzuns. Habib tells the police later that nailing up a house is a sign that the occupants are no longer welcome. The Makal family is no longer seen around town. They have moved to a nearby town, and Makal returns once a week to collect his mail. Meanwhile, Uzun has driven to Turkey to pick up his daughter. He had difficulties obtaining leave as he had just returned from holiday. In Turkey, Meral tells her father that Makal had raped her and that she felt she had no option but to go with him. Two weeks later, father and daughter return to the Netherlands.

When they have been back for a week, Fakir and Özkök arrange a meeting to discuss what should happen to Makal. They meet in the house of Fakir's son. Present are Özkök, Fakir and his two sons, Uzun and his son Habib, and son-in-law Reşat. Habib is appointed to carry out the honour killing.

The next day, Uzun accompanies Fakir and Özkök to buy a gun. Fakir knows where to go and Özkök lends Uzun the money (1,200 guilders). That evening, Uzun shows Habib the vacuum cleaner bag where he has hidden the pistol. They arrange with Mrs. Fakir, who lives in the street where Makal's old house is, to let them know when Makal returns to pick up his mail. Four days after the meeting, Meral tells Habib, who is in his bedroom,

that Mrs. Fakir has called in to say that Makal is at his house. Habib dresses in his sister's clothes and hides near Makal's house. As soon as Makal gets into his car, Habib runs up and fires straight through the left side window of the car from a distance of two metres. He fires seven shots at Makal's head and upper body: Makal is killed on the spot.

When he returned home, Habib asked Meral to put on the clothes – her own clothes – that he had been wearing. She refused. The following day, Habib gave himself up to the police. He claimed that he had worn his sister's clothes so that Makal would not recognise him straight away: he was afraid that Makal had a gun. Makal did in fact have a gun – under the driver's seat. Meral said that she was expected to put on the clothes so that it would look as though she had carried out the killing. Habib denied this. However, Meral's story seems quite plausible. Her family needed to present the 'rape' as convincingly as possible so that no blame could be attached to their daughter. A girl's story is all the more credible if she is the one who does the honour killing. Meral was no longer a minor, so the family's appointment of her as the honour killer was not an attempt to nominate someone who would be eligible for a shorter sentence.

After the honour killing, the family did everything in their power to alter Habib's falsified date of birth. It was no longer convenient for him to appear two years older than he actually was. The public prosecutor, who wanted him tried as an adult, demanded a four and a half-year prison sentence. However, Habib was tried as a minor and sentenced to six months in borstal. Because six months had already lapsed, he was released on the day of the court case. The local Dutch paper was highly indignant at this: 'The murderer released on the day of the trial – how can that happen?'⁴ The public prosecutor also lamented the situation: 'I find the sentence of six months in borstal insufficient for murder. I am also afraid that this penalty will encourage the Turkish community to appoint young people to carry out honour killings.'

An unusual aspect of this case study is that we are so well informed about the consultations that preceded the honour killing. Usually, the killer maintains total silence on the subject. Habib and his father told the police that they carried out the killing under pressure from their compatriots, Özkök and Fakir. But when the case came to an appeal, they withdrew their accusations, probably under pressure from these two men. The court had no option but to acquit the two accomplices. Ultimately, of the accomplices, only the father

was sentenced. He received three years' imprisonment for incitement to murder.

According to Uzun and his son, Fakir and Özkök insisted on the honour killing because they wanted to protect the Turkish community in the Netherlands from Makal. He was an honour violator who posed a threat to the *namus* of other Turkish girls. It would be better to kill him, rather than risk more questions of honour arising. The court records, however, reveal a less noble motive for the honour killing. Meral Uzun spoke of Makal's hatred for Fakir and Özkök. It seems that Fakir and Özkök, like Makal, owned a van for ferrying Turkish women and girls to and from factories in the vicinity. When Makal lowered the fare, Fakir and Özkök felt obliged to follow suit, which had led to arguments. Makal apparently had a great aversion to Fakir and Özkök, as evidenced by his asking Meral to write home to say that both Fakir and Özkök had indecently assaulted her. Meral later said that her claim was not true. It may well be that, for reasons of competition, Fakir and Özkök decided to use the honour question confronting the Uzun family as a legitimate cover for eliminating Makal.

Similarly, in the Altuğ case study, it appears likely that an outsider used the family's honour question to press for a killing. The girl, Mihriban Altuğ, was deflowered by Hacı Kalkan. Mesut Altuğ, the 19-year-old honour killer, claimed when questioned that a certain Akbulut had urged him to carry out the killing. He said that Akbulut was probably packing his belongings at that moment in preparation for leaving the country and hence avoiding arrest as an accomplice. When the police went to check on Akbulut, they indeed found him preparing to leave for Turkey. As far as the police could deduce, Akbulut had incited the Altuğs to kill Hacı Kalkan because the two were involved in a blood feud. The details are unclear on this point. The killing took place at Akbulut's house, where Hacı Kalkan had been lured in connection with car repairs. It is difficult to imagine that Hacı Kalkan would set foot in the house of a man with whom he was involved in a blood feud. Akbulut clearly had an interest in killing Hacı Kalkan, but we do not know the particulars.

5.3. A crime of passion

THE KÖKSAL CASE STUDY: 'THE PHONE BOOTH' (1992)⁵

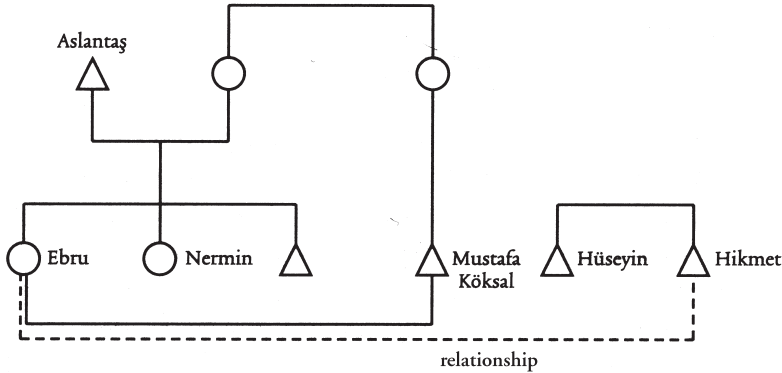

Fig. 9: The Köksal case study

At six forty one morning, the police receive a phone call. The caller is Ebru Köksal-Aslantaş, a 17-year-old Turkish girl who has been married for three months. She says that she has shot someone and that she is in a phone booth near the scene of the crime. When the police arrive, they find a young Turkish man dead in the driver's seat of his car. It is 26-year-old Hikmet. He has been killed by shots fired through the car window. Ebru says that she shot him and she throws a gun to the ground. The police immediately wrap her hands in plastic to safeguard any evidence. At the police station, Ebru claims that Hikmet had raped her a week before her wedding. She says that she became pregnant by him and had an abortion. According to her, Hikmet is definitely the father because she has never slept with her husband, Mustafa.

When the husband was questioned, it emerged that he had never had sexual relations with his wife. Enquiries at Ebru's doctor revealed that she had indeed been pregnant and had had an abortion. However, there were doubts about the rape claim as Ebru refused to go into detail. The police found photos taken at an amusement park that showed Ebru and Hikmet together. Ebru denied the existence of these photos. Her husband told the police that Ebru rejected his advances in bed. The house contained almost no women's clothes. It

appeared that Hikmet was Ebru's boyfriend and that she did not live with her lawful husband. The 'rape' story was eventually disentangled. This is what had happened:

Ebru is the eldest child of Mr. and Mrs. Aslantaş. Aslantaş comes to the Netherlands in 1966, and Ebru is born in 1974. When she turns sixteen, she is engaged to her nephew, Mustafa Köksal, who lives in Turkey. A large engagement party is held. Mustafa and Ebru are 'teyze çocukları' (in other words, their mothers are sisters). Mrs. Aslantaş and Mustafa emphasise later to the police that the engagement had been Ebru's wish: her parents felt that she was too young. Ebru's sister, Nermin, says that Ebru confided in her at a family picnic that she thought Mustafa was very nice.

Six months later, Ebru and her father travel to Turkey for the civil marriage, which is a prerequisite for Mustafa to come to the Netherlands. He is not entitled to a visa from the Dutch Consulate unless he has proof that his wife lives in the Netherlands. According to Mrs Aslantaş, Ebru then rings many institutions in the Netherlands to arrange for Mustafa's arrival. Ebru goes to work at a market garden because she cannot have Mustafa brought to the Netherlands unless she has an income of her own. Her employer, a labour contractor, is the 33-year-old Hüseyin, who drives his employees to the various market gardens. After Ebru has been working for two months, Hikmet, Hüseyin's younger brother by seven years, becomes a partner in the business. Ebru then goes to and from work with Hikmet. A relationship develops between the two of them.

Later, Hatice – a friend and workmate of Ebru's – informs the police that Ebru had told her that she regretted her engagement to her cousin and that she was in love with someone else. She did not dare tell her father. "I often saw Hikmet and Ebru together," says Hatice. "They were obviously having an affair. I couldn't believe it as she was already engaged. Other co-workers also talked about Ebru. In the summer, we all went to an amusement park, Hikmet and Ebru as well. Photos were taken of the two of them together." Melahat, another of Ebru's co-workers, also tells the police that there was a lot of talk at work about Ebru and Hikmet. She once asked Hikmet if he was having a relationship with Ebru. He denied it, but it was clear to her that he was.

Even before the trip to the amusement park, Mustafa, Ebru's fiancé, comes to the Netherlands. There is no reference to a 'husband' because the imam ceremony has not yet taken place. Until the wedding, Mustafa stays with various relatives in the same town. In the meantime, Ebru accompanies her family to Turkey on holiday. The wedding invitations are printed

during this time; the wedding dress has already been ordered. While on holiday, Ebru twice rings work and asks to speak to Hikmet.

The wedding of Ebru Aslantaş and Mustafa Köksal takes place in autumn. At the wedding, everyone gossips about the bridal couple because they spend no time together all evening. Aslantaş tells the police that they were very distant toward one another. The wedding night follows. The sađdıç (the bride's companion) goes to Ebru and Mustafa's house at night to collect the proof of Ebru's virginity – a white sheet with a blood stain – which she gives to Ebru's mother. Unknown to everyone, this proof has been faked. Ebru did not want to go to bed with Mustafa and made a bloodstain on the sheet. Mustafa later tells the police: 'Ebru took care of the sheet.'

Süleyman, a friend of Hikmet's, tells the police that Hikmet told him in confidence a week before the wedding that he and Ebru wanted to get married. Süleyman had replied: "Well, then you're just in time. Couldn't you find another girl?" Hikmet did not appreciate this response and asked him not to tell anybody. Süleyman promised to keep his mouth shut. Mrs. Aslantaş says: "After the wedding my daughter did nothing but brood. I thought she was ill." Ebru's sister, Nermin, tells the same story: "Ebru became less cheerful and you couldn't talk to her anymore."

Ebru's parents discover what the trouble is. Ebru tells them that she would like to marry Hikmet. Her father indicates that she has to be content with Mustafa: after all, he has spent so much money on them: 17,000 guilders for furniture, 10,000 for the wedding and 2,000 for Mustafa's mother's fare from Turkey to attend the wedding. Ebru's parents do not wish to hear anything about a relationship between Ebru and Hikmet.

In the first week following the wedding, Aslanta goes to talk to Hüseyin (Ebru's employer and Hikmet's brother). Aslanta demands that Hikmet leave town. He tells Hüseyin that he will shoot Hikmet if he shows his face. He shows his pistol to Hüseyin. He also threatens to do something to Hüseyin's daughter if the affair between Ebru and Hikmet continues. After that, Hikmet is no longer seen about town. He moves in with his Dutch girlfriend, Johanna. Friends say he does this in order to forget Ebru more easily.

Two months after the wedding, Ebru tells her best friend, Fatma, that she is two months pregnant by Hikmet. Before her marriage to Mustafa, she had tried to become pregnant so that she would not have to marry him. But it was too late; she did not discover her pregnancy until after the wedding. Ebru phones Hikmet to tell him that she is carrying his child. She asks him whether he will marry her. He refuses. He wants her to have an abortion because he does not want a child of his calling another man "Daddy".

Ebru tells her parents that she is pregnant and that Hikmet is the father. Her parents are now prepared for her to marry Hikmet after all. Their

change of heart may have been brought about by the knowledge that things are not working out between Ebru and Mustafa. Aslantaş visits Hüseyin in December to ask whether a marriage between Hikmet and Ebru might not be possible after all, since Ebru is carrying Hikmet's baby.⁶ Hüseyin tells Aslantaş that it is too late now and that they should have arranged things before Ebru's marriage to Mustafa. He says that Ebru should have an abortion. Aslantaş then threatens to kill Hüseyin, Hikmet and their family because they have been the cause of his daughter's disgrace. Mrs. Aslantaş also talks to Hikmet. She says: "Come and get Ebru, she's carrying your baby." Hikmet refuses. Ebru goes back to live with her parents and has an abortion.

Hikmet, who lives with his girlfriend, leaves home every morning at six thirty and travels to work by car. At six forty one morning, the police receive a phone call...

If a boy or girl changes their mind about an engagement, it is usually not too late to stop the wedding. In Ebru's case, however, preparations were too far advanced. The civil ceremony had already taken place and considerable costs had been incurred. If breaking off the engagement seems too difficult, there is always the option of an elopement (*kız kaçırma*). Ebru could have eloped with Hikmet. They could then have married and the marriage to her fiancé⁷ would not have gone ahead. In rural Turkey, an elopement is a very common means by which to circumvent an arranged marriage. Hikmet was even advised by a friend of his to elope. According to the friend: 'I knew about the relationship between Hikmet and Ebru and the fact that Ebru was going to marry someone else. I advised Hikmet to elope with Ebru so that he could marry her [...]. When I asked him about it later, he said that Ebru had told him that she couldn't run away. She would arrange something after the wedding. I couldn't understand it.

Ebru explained that she tried to become pregnant by Hikmet so that she would have a reason for not marrying Mustafa. This is not a customary solution, especially when the marriage to the – now unwanted – fiancé is so close. Ebru probably did not dare elope because the bridegroom was the son of her mother's sister, who lived in Turkey. This boy's expectations had been raised by the prospective marriage to Ebru; it meant an opportunity to come to Western Europe, a welcome prospect not only for Mustafa, but for his parents as well. Mustafa's behaviour toward Ebru reveals that he wanted to live in the Netherlands. What husband accepts a wife who will not sleep with him? But Mustafa had no choice; he was probably much too afraid

that Ebru no longer wanted him and that he would have to leave the country. I suspect that their story ended as follows. Although living apart, Ebru and Mustafa stayed officially married for three years, after which they divorced. In this way, Mustafa would have been married for the minimum number of years required for him to be able to stay in the Netherlands.

It is quite apparent in this case study that Ebru could not have carried out the honour killing. The police found no glass fragments from the car window on her hands or clothing. Nor did they find traces of gunpowder, which is surprising given that Hikmet was shot at such close range and that Ebru was apprehended just ten to fifteen minutes after the shooting. The Forensic Laboratory in Rijswijk carried out gun tests with four marksmen in order to see whether gunpowder traces could be expected. All had powder traces. Moreover, five out of seven shots went right through the car window and hit their target, a difficult feat according to the police. The investigation revealed that the shots must have been fired by an experienced and proficient person.

This was evidence enough for the police to assume that Ebru was not the killer. Instead, they suspected her father. They also suspected that Ebru was made to claim responsibility for the killing: firstly, because she was a minor and would be given a lighter sentence than her father, and secondly, because it would lend credibility to the rape claim. The assumption was that, because a woman would not kill her own lover, the fact that Ebru killed Hikmet proved that he must have raped her.

Right up to the time of the court case, Ebru maintained that she committed the killing and wanted to be punished for it. She was charged with 'the deliberate and premeditated taking of Hikmet's life.' Her counsel pleaded that she be acquitted, saying: "I am aware that this does not comply with the defendant's wish and she knows this." Ebru was acquitted because she could not possibly have committed the crime. Despite the suspicions of the police and the judiciary, the case against Aslantaş was dismissed for lack of evidence.

Ebru seems to have played the role of reluctant heroine throughout. Once her relationship was discovered, it appears that her family forced her to accept responsibility for the honour killing, or else be killed herself. However, the detective inspector in charge of the case was not convinced. He visited Ebru several times at the remand centre and failed to detect any sign of regret or sorrow. His theory was that Ebru told her parents that she was pregnant by Hikmet when

she realised that he no longer wanted to marry her. She could have kept silent about the abortion, but she wanted to avenge herself: he had abandoned her, and deserved what was coming to him. The fact that Hikmet moved in immediately with his Dutch girlfriend may have intensified her negative feelings toward him. We do not know if she was aware of this relationship, but if she was, Hikmet will undoubtedly have told her that it was temporary, and that she was the one he wanted. This honour killing is a *crime passionnel*, in which the unfaithful lover was murdered.

The Çetin case may also have been a crime of passion. Mrs. Kalemli-Çetin claimed that Özbay had raped her on two successive evenings. Her brother heard about the rape and killed Özbay. According to the official version, he acted entirely alone: Mrs. Kalemli and her husband knew nothing about it. I stated earlier that I regard Kalemli as a likely accomplice, and that Mrs. Kalemli probably knew about the plan too. What I now wish to add is that Mrs. Kalemli may not have resigned herself submissively to the killing of her boyfriend, but may have wanted it to happen. The court records reveal that Mrs. Kalemli and Özbay acted very coolly towards one another six months after the summer camp, which had not been the case earlier. It seems that their relationship had come to an end. Several witness testimonies reveal that Özbay had a reputation for being a ladies' man. Had Özbay found another lover and dropped Mrs. Kalemli? The honour killing may have been Mrs. Kalemli's revenge against a lover who had lost interest in her. The court records do not reveal any suspicions about her role as accomplice. That does not mean that there were no such suspicions, simply that nothing to that effect was recorded because of lack of proof.

5.4. Sexual insults

THE ERCAN CASE STUDY: 'TWO CARVING KNIVES FROM HOME' (1982)

In a bar, Dayıođlu is offered a beer by Ercan, a 25-year-old Turkish man. When Dayıođlu refuses it, an argument follows. The owner throws them out and the fight continues outside, witnessed by compatriots. Dayıođlu utters the insult 'I'm sleeping with your mother and your wife,' and then makes a stabbing motion with his knife. Ercan is furious. He goes home, fetches two carving knives and comes back in search of Dayıođlu. He asks

everyone he knows where Dayıođlu is, and says to them all, “I’m going to kill him.”

Someone phones the police, but while the police search the area for Ercan, he has already found Dayıođlu in an alleyway. It is eleven thirty at night, and Dayıođlu is on his way home. Ercan snaps at Dayıođlu, saying that he shouldn’t have insulted his wife. Dayıođlu replies that he doesn’t want to fight. A Turkish witness who hears this exchange hurries into a café to phone the police, but it is too late. When he returns, he sees that Ercan has stabbed Dayıođlu. The witness goes back into the café with Ercan. Ercan places the knives on the table and says: “If he stands up again, I’ll cut his throat.” The police arrive soon afterwards and arrest Ercan.

The court sentences Ercan to four years in prison for manslaughter. On appeal, he is given a five-year term for murder. The Court of Appeal grants him a six month reprieve, perhaps because he will be deported once he has served his sentence.

This is an example of an honour killing following a sexual insult. A man’s *namus* has been sullied by words alone. Insults of this kind occur between men. If uttered in public, and in the presence of compatriots, words may be even more serious than a physical attack. The Turkish word for sexual insults is *küfür* (curses). A more precise word is not used in everyday language; if you say *küfür*, everyone knows what you mean.⁸ Men who are the target of a sexual insult take the matter very seriously indeed. Ercan claims that the insult brought tears to his eyes. The insults I am referring to here are the following: ‘I’m fucking your mother’ (*ananı sikerim*), ‘I’m fucking your daughter’ (*kızını sikerim*), or ‘I’m fucking your mother and your wife’ (*ananı avradını sikerim*). A second type of sexual insult is to suggest, by calling a man a ‘bastard’ (*piç*) or ‘son of a whore’ (*orospu çocuđu*), that his mother is a ‘whore’.⁹ A third category involves calling another man’s wife a ‘whore’, or calling a man a ‘pimp’ (*pezevenk*). In the Black Sea region, they say *kavat* for ‘pimp’, whereas *dümbük* is more common in the Chukurova.

A man may be called a *boynuzlu*, in other words ‘a man with horns, a cuckold’, which suggests that he allows his wife to commit adultery. The allusion here is to the horns of a he-goat, as he-goats do not object to other he-goats mixing with their females.¹⁰ In this respect, goats are unlike rams, which do watch over their ewes. In Turkey, the word *koç* (ram) is used as a compliment for men and boys: *Koç gibisin!* (You’re just like a ram!), with *Koç* being a common surname (the law on surnames was introduced in 1934).

Some curses may look like sexual insults but are not. Men use them as conversation fillers when talking to one another, e.g. *siktir lan* (get fucked), and *amına koyayım* (put it in her cunt). The words *piç*, *orospu çocuğu*, or terms meaning ‘pimp’ are used among friends in a less charged sense. Turkish men think twice before uttering a sexual insult; they are fully aware of just how serious and dangerous this can be.¹¹

So when are *küfür* of this kind used to offend? The above case study suggests several preconditions. Firstly, a dispute has already taken place. It is difficult to establish the truth in such matters, however. The victim is dead and therefore unable to provide information, and it is not in the interest of the honour killer to elaborate on any conflict. If we look at what Ercan says, everything hinged on the sexual insult uttered by the victim. It seems as though the curse came ‘out of the blue’, completely unmotivated. This hardly seems plausible, especially since the perpetrator and victim were acquainted. Ercan knew Dayıoğlu: when Ercan returned with the knives and could not see Dayıoğlu at the bar, he headed purposefully for the alleyway, knowing that Dayıoğlu lived there. Thus, the motive for an honour killing may not only be the sexual insult itself, but also an underlying dispute.

Secondly, alcohol consumption may make it more likely that a sexual insult is uttered, just as the killer may be more sensitive to a curse of this kind if he has been drinking.

A third reason may relate to personality. Dayıoğlu was quick to offend. He was 43 years old, unemployed and single; the latter being highly unusual for a Turkish man of that age. Four years earlier, he had been arrested for illegal possession of a firearm. He was known to be aggressive and had often threatened others with knives. He was an outsider who quickly and frequently irritated his compatriots. We might therefore wonder why Ercan did not ignore the curse, given who had uttered it. Turkish witnesses assured the police that nobody took Dayıoğlu’s curse seriously and that Ercan should not have allowed himself to be upset by it; everyone knew what kind of person Dayıoğlu was.

The fact that Ercan did lose control relates to his personal circumstances. In 1972, Ercan had accompanied his mother and four younger siblings to the Netherlands to be reunited with his father. After completing a six-month language course, he started work in a factory. In 1975, his mother returned to Turkey with the four youngest children, while Ercan stayed in the Netherlands with his father. Be-

fore long, the two of them started arguing. Ercan moved into rental accommodation and saw his father infrequently. When he turned twenty, he was called up for military service in Turkey. At the age of twenty-two, he returned to the Netherlands, where he worked in the building industry as an unskilled labourer. The following year, he married a fourteen-year-old girl from the village where he was born. The flat he rented was quite expensive, and he had to buy furniture and kitchen equipment. As he did not earn very much, he soon got into financial difficulties, and he and his wife faced an acute shortage of money at the end of each month. According to Ercan, this led to considerable tension. On the night in question, their financial problems had reached crisis point. Ercan decided to try and borrow money from a compatriot. He was probably already very tense when he went into town; after all, if he could not get his hands on some money, he and his wife would simply not be able to manage. A single incident was all it took for him to explode, and Dayıoğlu's refusal of a glass of beer was the last straw. Ercan did not let matters rest, which had fateful consequences.

It emerged later that the Ercans' financial difficulties were indeed considerable. Ercan confessed to the probation officer that he was very concerned about his wife, who had no money to buy food. The officer arranged for her to receive an advance payment. There were also outstanding rent payments, for which a debt repayment scheme was introduced. Ercan's wife was in the final months of pregnancy when Ercan committed the honour killing, and the baby was born while he was awaiting trial. The costs associated with the new baby came on top of all their other expenses.

In short, in the event of an honour killing following a sexual insult, there is probably more involved than an inability to tolerate a verbal insult. Nevertheless, an insult of this kind may act as a catalyst.

5.5. Pathological honour killing

THE ALTUN CASE STUDY: 'THE FLANNEL' (1991)

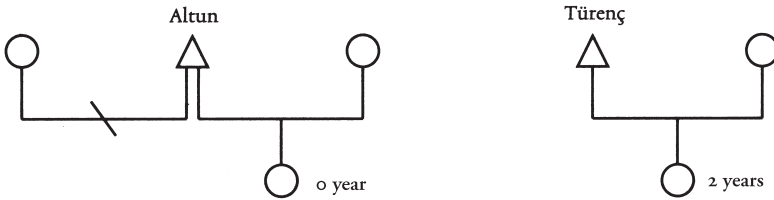

Fig. 10: The Altun case study

Altun has just remarried when he and his second wife move into a new apartment. They share a stairwell with another Turkish family, the Türeñçs and their two-year-old child. The two families call on one another to introduce themselves but have no further contact. According to Altun, Türeñç soon begins making veiled allusions to his wife. Four months after they have moved into the building, it all becomes too much for Altun and he decides to say something. Türeñç replies that Altun will never catch him at it. Altun deduces from this comment that there is something going on between his wife and Türeñç. He now remembers the incident with the flannel. Mrs. Türeñç had given a flannel to Mrs. Altun, saying it belonged to them. Only now is Altun able to place an interpretation on this: his wife has slept with Türeñç and left the flannel behind.

After living in the apartment building for seven months, Altun buys a dagger in the event that he is able to uncover sufficient evidence of adultery. Three months later, he believes that the time has come. His wife has just had a baby and Türeñç comments that Altun now has to look after a child of Türeñç's. This remark haunts Altun. He goes to Türeñç's flat that evening to demand an explanation. No one answers. Altun goes outside and sees lights burning in Türeñç's flat. For him, the fact that Türeñç did not open the door simply confirms his suspicions. He lies awake all night wondering whether the child is his.

The following morning, he goes straight to Türeñç's flat. He rings the doorbell and Mrs Türeñç opens the door. Türeñç comes into the corridor as well, holding his child by the hand. He says to the child: "Look who's here." Altun says later that he was furious at the disparaging tone in which Türeñç

spoke, and that all his frustrations boiled to the surface. He takes his dagger from his pocket and stabs Türeñç, who dies from his injuries. When the police arrive, they find Altun walking along the street.

This is an example of a pathological honour killing. The perpetrator carried out the killing because he imagined that his wife was unfaithful. The psychiatric term for this pathological obsession is the Othello syndrome, after the main character in Shakespeare's eponymous play. Like Othello, people suffering from this condition see signs everywhere that point to their spouse's adultery,¹² whereas in reality, there are no such clues. The Othello syndrome, sometimes referred to as sexual or morbid jealousy, is defined in clinical psychiatry as the delusion of infidelity, in other words, the unfounded belief that the sexual partner – wife, girlfriend, or mistress – is sexually unfaithful. We encounter this illness in all societies.¹³

It soon emerged that the Altun case involved a pathological killing, as Altun had attempted to murder his first wife five years earlier for the same reason. As a result, he was placed under medical treatment. Altun's neighbours were aware of his history. The wife of the deceased neighbour said: "Altun didn't have a particularly good name in the Turkish community. There were all sorts of stories about him. He also suspected his first wife of carrying on with other Turkish men. He even accused his own brother. My brother-in-law, who works with him, warned us not to have any contact with Altun [...]. All we did was introduce ourselves and say hello if we bumped into each other in the street." Nevertheless, they were unable to prevent what happened.

We encounter a further pathological honour killing in the Akkaya case, in which Akkaya killed his wife's alleged lover and then his wife. In contrast to the Altun case study, the pathological nature of this case was not recognised until a late stage. In the court case and the subsequent appeal, attention focused on honour killing as an aspect of Turkish culture. Not until the case came to the Court of Appeal was a psychiatrist called in, who arrived at a different conclusion. He initially stated in cautious terms: 'I think there may be something pathologically wrong with this man', 'I cannot altogether rule out the possibility that this man has paranoid tendencies', and finally, quite specifically: 'The subject has a limited awareness. He is convinced in terms of his own mental processes that his observations are correct and that denials from his wife should be seen as a kind of lie. Arriving at absolute certainty by col-

lecting evidence using one's own reasoning verges on delusion; we call this '*wahnhaft*'.

In the Biber case study too, the honour killing was the result of the father's extreme jealousy. It is difficult to say whether it was pathological in this case. Throughout the trial, no attention was paid to the father's character, although there was evidence even before the murder of the affect that he had on the behaviour of other members of his family. One year before the crime, a child psychologist wrote in a report: 'All the children have suffered severe psychological damage as a result of neglect, violence, lack of stimulation, and marital disputes. The behaviour, or illness, of the mother is a special factor, although in my view her behaviour cannot be separated altogether from the repression, power play and violence of the husband/father.'

Yeşilgöz, who included this case study in his doctoral dissertation, does not give specific attention to the father's conduct.¹⁴ He accepts the account of the honour killing given by father and son, and describes the mother as a woman with several lovers. However, this may simply have been an attempt on the part of the father and son to blacken her character (see also the Dursun brothers' comments about Zeynep in the Dursun case study).

Mrs. Biber probably did not have a lover or lovers, despite the claims to the contrary from her husband and son. They contradicted themselves when speaking about 'mother's men friends' one moment, and a specific boyfriend – Mustafa – the next. Upon closer inspection, the police records reveal that Mustafa was the husband of Aunt Güzin, a Turkish friend of Mrs. Biber's. It appears that Mustafa was viewed as Mrs. Biber's boyfriend because he was the only man with whom she had informal contact (ie. outside the official support agencies). When Mevlüt was waiting in the bedroom of his mother's flat in order to – in his own words – stab them both to death, it was only his mother who came home.

Biber had been suspicious of his wife right from the start of their marriage. He imagined that she was not a virgin on their wedding night. When she was in hospital, he was convinced that she was having affairs with other men; he kept visiting her there, even outside visiting hours, to check on her. According to Biber, she misbehaved constantly and the entire neighbourhood gossiped about her: he and his family had to move house three times to escape. The question we should ask is whether in fact there had been any gossip at all.

A former Turkish neighbour described Biber as follows: "Biber moved out of our town because he thought that rumours were circu-

lating within the Turkish community about his wife's conduct. But I know for certain that the Turkish community did not talk about the family. So in my view there was no reason to move. I think that Biber's jealousy gave him delusions about his wife's behaviour. I suspect that Biber incited his son Mevlüt to murder his mother. I don't think Biber could rest until his ex-wife was dead." The neighbour also said: "Biber had a difficult personality. I know that he was very jealous. For instance, he believed that his wife had gone out with several other men. Especially when his wife was admitted to hospital, Biber believed that she was seeing other men." The Dutch wife of the former neighbour said about Mrs. Biber: "We were neighbours of the Biberes. I thought they were a good family. Mrs. Biber was certainly very modern. In the period in which we were neighbours, I came to know her as a completely normal, decent woman. I do know that later, after they moved, she was confused for a time."

The probation officer's report also showed Biber to be a very jealous man: "He still [after the honour killing] appears to be obsessed by the idea that his wife was a whore. I base this on the fact that the subject keeps cropping up in our talks. Mr. W. of the Regional Institute for Mental Welfare (RIAGG) did not believe that Mrs. Biber was guilty of misconduct. She made a positive impression on him. She came across as a woman who did her best to be a good mother. According to him, she could not cope with the pressure [...] from her husband, who spoke to her in a very peremptory and demanding tone." If we look at the records in this light, we can better comprehend Mrs. Biber's mental illness: her husband's suspicions may well have been the cause of her illness.

It is symptomatic of this condition that a man not only believes that his wife is unfaithful but that many people around him know about it as well, which only serves to make him feel more wretched.¹⁵ In a letter, in Turkish, to the court, Akkaya wrote: 'It seemed as though everyone was looking at me and laughing at me. If I looked at my children, I felt that they were too ashamed to look at me, as if I had committed a terrible crime. It seemed as though they preferred not to see me.'

The slightest evidence is seized upon to confirm the delusion. Even a small change in the home is an indication that someone has been there with the sole purpose of 'doing it' with the man's wife.¹⁶ In the Altun case study, finding a flannel was enough to make Altun suspect his wife of having a sexual relationship with the downstairs neighbour. Given that people suffering from this condition may be

sensitive to the slightest change at home, Akkaya had every reason to misinterpret things completely: his wife was pregnant *and* he sublet to a married couple. When Akkaya noticed that his wife's lips were swollen, he concluded that she had a lover, namely Faruk Taş, the male subtenant. In reality, she may have been retaining fluid as a result of her pregnancy. When his wife moved her step-daughter from their bedroom, which she had shared, into another, Akkaya saw this as evidence that she was having a sexual relationship with Faruk Taş. In reality, this may have been due to the baby's arrival and the fact that his wife preferred to have the baby's cot in their room. There was no room for the cot unless the stepdaughter moved to another bedroom. When the baby was one month old, Akkaya awoke during the night on two occasions to discover that his wife was not lying beside him but was downstairs. He believed that she went downstairs to be with her 'lover', whom he had since evicted. What is more likely is that the baby cried in the night and his wife took the baby downstairs so as not to wake him. Significantly, the wife of the honour killer in the Altun case study had also just given birth. The period during and immediately after their wife's pregnancy is perhaps a particularly risky time for men with this illness because of the many changes that occur.

People who suffer from delusions of infidelity go to great extremes to test their partner. Many search their spouse's clothing for traces of sperm. Akkaya subjected his wife to a vaginal examination, which is symptomatic of the illness. The sufferer's so-called 'evidence' is often flimsy and contradictory, but this does not prevent these men from subjecting their wives to further interrogations in an attempt to extract a confession. Even if satisfied with the responses at the time, they quickly return to the same kind of questions, with the result that the conflict and arguments escalate, sometimes leading to violence. Because a confession only aggravates the conflict and may end in disaster, it should be avoided at all costs. Sometimes women abandon the fight and 'confess' for the sake of peace, but the result is anything but peace.¹⁷ The records show that Akkaya and Altun questioned their wives for hours until they were convinced that their wives had lovers.

The delusion is aggravated if there is a discrepancy in the intellectual, educational, and social levels of the sufferer and the partner.¹⁸ This is not clear in the case of Altun, but it may have been an issue for Biber and Akkaya. A former Turkish neighbour of the Bibers described them as follows: "They came from very different back-

grounds. She came from the city of Istanbul and was very modern. He came from a small village and was much more orthodox. From a Turkish point of view, Mrs. Biber was too modern in her conduct.” This difference also emerges in their language skills. Mrs. Biber spoke very good Dutch, whereas her husband did not. In the case of the Akkayas, there was a large age gap between husband and wife. Aged twenty-two, Mrs. Akkaya was nineteen years younger than her husband, which suggests a form of social discrepancy.

The prospects of recovery are very doubtful. The more classic the symptoms, the longer the duration of the illness. Unaware of how sick they are, sufferers lack the will to be treated.¹⁹ This appears to have been the case with Altun, who had already attempted an honour killing because of his wife’s supposed infidelity. Despite undergoing therapy in a clinic in Turkey, he committed the same error six years later. Strangely, this did not result in him being given treatment in the Netherlands. Altun was sentenced to seven years in prison for murder. Kriton Dinçmen, a psychiatrist, argues in the journal *Nokta*, that in order to prevent a repetition, pathological honour killers who wish to remarry should undergo a psychiatric examination.²⁰

5.6. Murder/manslaughter for reasons of male pride

THE YURTER CASE STUDY: ‘A FATAL DIVORCE’ (1990)

The 40-year-old Yurter has been living in the Netherlands for ten years and has been married to Hülya for thirteen years. Yurter is unemployed and has been receiving a benefit for five years. Hülya came to the Netherlands two years earlier, together with their youngest son. The eldest son stayed in Turkey with his grandparents on his father’s side because they are keen for him to have a Turkish education. Hülya decides to get a divorce because her husband gambles away all their money and beats her if she protests. Yurter is adamantly opposed to a divorce but Hülya persists. In the separation agreement, she is awarded the house, and the care of Yılmaz, their youngest son, who is nine years old.

Yurter has to vacate the house and go to live somewhere else. However, he does not leave his wife alone. He comes to the house regularly and beats her up. One month later, Hülya flees with her son to the house of some friends. Yurter discovers where she is staying and assaults her there too. The police arrest him and he is forced to spend three days behind bars. He also

has to relinquish the keys to his former house. The magistrate sentences him to two weeks' suspended prison sentence for intimidation. This is ineffective: that same month he drags Hülya out of a bus by her hair. She falls onto the road, hitting the back of her head, and is knocked unconscious. An ambulance takes her to hospital, where she has to stay for about a week. Yurter visits her in hospital too and threatens her there.

Hülya goes to Turkey in mid-July on holiday, returning to the Netherlands at the end of August. Yurter leaves her alone for a time, but at the end of October he manages to get into her house after a top window has been left open. He hits his wife and threatens to kill her and her son. He snatches a knife from the kitchen table. Hülya manages to escape into the bathroom with her son. At night, they flee the house. Hülya files an assault charge and initiates divorce proceedings. Several days later, she has to flee from Yurter once more. She returns to the friends where she had stayed earlier. Yurter knows the address and beats her up so badly that she has to go to Accident and Emergency to have stitches in her head.

Hülya goes into hiding for several weeks. She then returns to her own house because she believes it is important for her son to attend school regularly, and because it is not clear how long she will have to wait for alternative accommodation. Yurter is arrested, but denies having threatened and beaten his wife. He claims that she slipped and fell.

In December, Hülya's lawyer applies for a restraining order against Yurter. It is granted but to no avail. Yurter constantly rings Hülya's doorbell, but Hülya never opens the door. He then thinks up another way of gaining entry. Away at her cleaning job, Hülya is never home in the afternoon, but her son has a key to let himself in after school. One afternoon, Yurter waits for his son outside the house and demands that he give his father the key once he has opened the door. Yılmaz says later: "My father said: 'If you don't give me the key, I'll hit you.' I got so scared that I gave him the key." Yurter also told Yılmaz not to tell anyone that he had the key.

At about eleven o'clock that evening, Yurter creeps into the house. He beats Hülya unconscious and rapes her. Hülya becomes pregnant and has a curettage a month later. That year, the divorce hearing takes place. Hülya wants a divorce but Yurter does not. The judge does not understand: "There is something strange here because the statements from both parties are completely contradictory. Perhaps it's a question of fraudulent use of two benefits? Perhaps they don't dare say so. I don't know." The case is adjourned.

Yurter tells his wife that he will kill her if she pursues with the divorce. Another restraining order is taken out against Yurter. In November, the di-

voice comes through and Hülya is granted another house in another town. The address is kept secret from her ex-husband.

At the end of December, Yurter goes to Turkey. He returns to the Netherlands in February and asks various members of Hülya's family where his wife lives. Nobody tells him. Yurter then goes to his wife's workplace and tells her that he wants to see his son, Yılmaz. Hülya does not want to refuse him this and they arrange a meeting – not at her house as she wants her address kept secret – but at the house of Türkân, a friend of hers.

Yurter arrives on the appointed afternoon. When the friend leaves the room for a moment, Yurter attacks his wife. Yılmaz witnesses the attack; he sees his father stab his mother until she lies motionless on the floor. She dies as a result of thirty-one knife wounds. Yurter is admitted to a forensic psychiatric clinic.

Yurter killed his wife because he could not tolerate the fact that she had left him. It meant complete humiliation for him: he had to leave the house, relinquish his keys, and he was subject to a restraining order. I question whether this act of murder/manslaughter should be seen as an honour killing at all, as the female victim had had no illicit contact with another man. I would prefer to call it 'murder/ manslaughter for reasons of male pride'.

Crimes of this kind came up during a panel discussion on honour killings among Turks in the Netherlands held at 'De Balie' in Amsterdam on 22 March 2000, and led by Ilhan Akel, Director of the Dutch Centre for Foreigners. Nurdan Çakıroğlu, a member of the panel, talked about her friend, Kezban,²¹ who was killed by her husband. Kezban had left her husband after he had repeatedly assaulted her. During the discussion, however, the 'Kezban' case was referred to as an honour killing. In the interval, I discovered how much this upset Nurdan: 'But my friend wasn't a whore. It wasn't her fault. It was her husband who made her life miserable.' Nurdan begged me to explain to the audience after the break. The audience's reaction was one of bewilderment: "What is honour killing then? And *two* words for honour, that's much too complicated." Unfortunately, there was no time to elaborate on the definitions, as we needed to talk about solutions to honour killing. Only then, however, did it become clear just how important the definitions of these terms were. The solutions consisted primarily of strategies for identifying physical abuse in time to prevent a woman from being murdered. My earlier statement that men could also be victims of honour killings was strenuously denied. In this kind of 'murder for reasons of male

pride', women – and perhaps in exceptional cases their children – are the victims. There is no male offender to kill.

Whether this type of murder/manslaughter constitutes an honour killing depends in part on the definition of *namus*. As I outlined earlier, *namus* is not a fixed concept; it differs from region to region and from town to town. Someone with a very rigid notion of *namus* will perceive the wife as the property of the husband; she must accept whatever treatment he gives her, even physical abuse. *Dayak cennetten çıkmadır* (a beating comes from heaven), *Erkek sever de, döver de* (a man loves his wife, but beats her too) and *Erkeğin vurduğu yerde gül biter* (where a man strikes his wife, a rose blooms) – these are all well known Turkish sayings.

We see evidence of this rigid attitude in *Meyro* by Necati Haksun, the judge referred to earlier who worked in Van, in Çatak Province in eastern Turkey, and whose novels and stories are based on true events. A man recounts what the village *hoca* (Sunnite cleric) constantly tells the women of the village: “Women! Heaven lies at the feet of your husbands. Do you know what that means? No matter how bad a husband is, his wife cannot rebel. She must do everything he says.”²² According to this view, a man’s *namus* is affected if his wife leaves him for any reason whatsoever, even if he beats her.

A woman’s conduct after she has left her husband is crucial to how she is perceived. A woman who can no longer tolerate living with her husband is expected to return to her parents, to move in with a married brother or sister, or to be protected by any adult sons that she might have.²³ She should not go and live by herself. Moreover, living in a refuge (*sığınma evi*) can be a source of irritation for many rural Turks, who view refuges as places where all is permitted and where a woman can acquire bad habits.²⁴

Turks to whom I explained the Yurter and Kezban cases were divided on the issue as to whether these constitute honour killings. Some Ankara residents did not see this type of murder as an honour killing. They included not only more highly-educated people, but also those with no education who came from the provinces and worked as concierges (*kapıcı*)²⁵ in the city. It is primarily women who do not view this crime as an honour killing. When asked how the Yurter case should be described, many replied: *Gurur meselesi*, ‘a question of pride’.

Sometimes when men kill their wives out of male pride, they then proceed to kill themselves. The following cases come from the *Hürriyet*: one man killed his wife after she left him and moved into a

women's refuge²⁶; in three instances, men became so frustrated when they heard that their wives wanted to divorce them, that they shot their wives²⁷; one man shot his wife because she wanted a divorce, and then turned his rifle on his children as well.²⁸ In all cases, the husband then committed suicide. Because these incidents were briefly reported, we do not learn whether the wives had lovers. However, it appears that the husbands committed the crimes because they could not bear the fact that their wives had left or were planning to leave.

Ergil, who classifies 'murder/manslaughter for reasons of male pride' as honour killing, gives the term 'extended honour crime' to these instances of suicide. He believes that suicidal tendencies only occur among the middle-class, urban population. His explanation is as follows: a middle-class man commits an honour killing if he believes his *namus* has been violated. However, given the socialisation of his class, honour killing does not confer any status upon him, and he therefore commits suicide in order to escape this intolerable situation.²⁹

I suspect that the men concerned are middle-class men who have lost status³⁰ and who have developed severe psychological problems. The murder and subsequent suicide appear to be committed in a fit of despair; they are not premeditated acts. In the cases involving witnesses, these witnesses used the following expressions to describe the state of the perpetrator: 'he lost control'³¹ and 'he went mad.'³² Moreover, in three of the five incidents, the woman survived the attack. They were thus murder 'attempts', which may point to the unplanned nature of the attack.

6. Alternatives to honour killing

It is not possible to ascertain how frequently honour killings occur in Turkey. The daily papers, with the exception of the *Cumhuriyet*, regularly report on such killings.¹ Although honour killing is a common phenomenon in Turkish society, this should not suggest that the decision to commit an honour killing is taken lightly. If questions of honour arise, people usually have recourse to an alternative, so that an honour killing can be avoided.² Honour killing is the most extreme solution: it only becomes an option when the alternatives have failed and the question of honour escalates.³ The reason that honour killings do not occur more frequently is that people do their utmost to prevent questions of honour from arising. The director of culture in Bitlis Province, who describes a number of honour killings and alternatives,⁴ says of his region: “*Namus* is so important in our society that you can only walk with your head held high if you have *namus* [...]. That is why we do not see much immorality in society. Everyone does their best to uphold this value.”⁵ By this, he means that there are few illicit relationships and hence no need for honour killings.⁶

I have not investigated questions of honour that were resolved peacefully. However, I will mention several alternatives because they feature in the court proceedings. Frequently, an initial attempt is made to resolve the honour question without a killing. In three case studies (Akkaya, Köksal, and Uzun), the perpetrator, the suspected accomplice, and the *imam*, respectively, made reference to alternatives. In addition, alternatives are revealed in the literature on the subject, or by informants. For unmarried girls, the main alternative is marriage. This fits within the first type of solution: ceasing to have primary responsibility for the girl or woman. Other alternatives are to do nothing, to do as little as possible in order to save face, to withdraw, to call in the authorities or, very rarely, to violate the *namus* of the male transgressor. As already mentioned in chapter one, *namus* involves the ‘eyes of the community’. For the family in question, everything hinges on how they are judged by the Turkish community to which they belong. Once a daughter or wife is talked about, the family must put an end to the gossip.

6.1. No more responsibility for the woman

Marriage

Whenever possible, a girl is married off immediately, either to the young man who has compromised her *namus* or to another. In the latter case, the bridegroom is often a man who has difficulties finding a wife because of his age, infirmity, or poverty, or because he is a widower. Other options are to marry the girl off to a relative who is prepared to erase the shame,⁷ or to a man who lives so far away that the gossip will not have reached his ears.⁸

A boy who elopes with a girl pins his hopes on marriage. He calculates that her parents will grant permission for a wedding in order to cleanse their daughter's *namus*. Unfortunately for the girl, parents sometimes adopt this alternative when their daughter has been raped or molested. For this reason, girls sometimes dare not publicise the incident.⁹ Even when the man in question is already married, the girl's father may insist on a marriage, so that she then becomes the second wife. In such cases, there is only an *imam* wedding, not a civil wedding. In the Altuğ case study, Altuğ's father even offered the male transgressor – a married man – money to take his daughter as his second wife. In the Uzun case study, Habib, the son, claimed that marriage to Makal would have been an acceptable solution, even though it would have made his sister Makal's third wife. Habib Uzun said to the police: 'If Makal were married to my sister, the family's honour would have been saved, but he left her in the lurch.'

If a girl is the subject of gossip, marriage to her fiancé usually ceases to be an option. However, Safilios-Rothschild points out that, in certain cases, a girl in Greece may still marry her fiancé after her *namus* has been violated, but that in such a case she must contribute a larger trousseau. Safilios-Rothschild reports that rich girls are generally exempt from the stringent rules governing chastity. They are able to marry, even if it is known that they had sexual relations before marriage. She concludes that female chastity and money are negotiable commodities on the marriage market: a poor but chaste girl may marry with a small trousseau; a girl with a dubious reputation may also marry, but must bring more goods to the marriage. The worse the reputation, the larger the trousseau required.¹⁰

The same may apply to Turkish girls in the Netherlands. Even girls who have been the subject of gossip may be attractive marriage partners for some young men in Turkey, as they are a means by which these men can acquire a Dutch residence permit. The residence permit then forms – as it were – a valuable part of the trousseau and compensates for the stain on the girl's *namus*. This should not detract from the seriousness of a question of honour. It is no consolation for Turkish parents in the Netherlands to know that they will always be able to marry their daughter off. Their preference is to marry her as a virgin to a boy whose family they know, and not to simply anyone.

Being sent away

Girls in the Netherlands who conduct themselves too freely may be sent, as a precautionary measure, to live with their grandparents or other relatives in Turkey.¹¹ Some parents opt for a boarding school in Turkey; these are usually parents who prefer to remove their daughters from a country where their *namus* is at risk. They feel extremely uncomfortable about the mixed swimming and physical education classes at Dutch schools, and prefer a traditional Islamic upbringing for their daughters.¹²

Sending girls away, either temporarily or permanently, is not only a precaution, it may also be a solution. A Dutch woman married to a Turkish man, and living with him in Turkey, describes 'sending away' as a means of circumventing a question of honour. The 15-year-old sister of her Turkish husband, Vahit, came to live with them: 'The poor child was caught writing a love letter. The family thought it a very good solution to have her live with her oldest brother, Vahit, for a while. They assumed that I would act as a kind of jailer, and I did, otherwise they would have taken her straight back again.'¹³ The unmarried Turkish girl who gave birth to baby Fatima (see 2.3) was also sent back to Turkey by her parents.

The same alternative was adopted in the Yiğit case study. When the father discovered his daughter in the shed with the boy next door, he sent her and her mother to an aunt who lived outside the village. In two other case studies, it emerged later that sending the unmarried girl away would have been an acceptable solution. In the Uzun case study, the *imam* told Uzun that Meral, the girl in question, should stay away for a year until the scandal was forgotten. In the

Köksal case study, Aslantaş said later: 'If I had known about the problems, I would have sent Ebru to Turkey.'

Married women may also be sent back to Turkey by their husbands, usually in association with a divorce. A woman staying in the Netherlands will be given accommodation and a benefit by the city council. Her independence will mean that her husband will not be able to subject her to his will. If she is sent to Turkey, unless she has a profession by which she can support herself, she has to live with her parents. Some men feel more comfortable with this idea, as it means that their ex-wife will have little opportunity to begin a relationship with another man. We learn from Deug that not merely the husband, but also the woman's family may want her to return to the parental home. When Inci, a separated Turkish woman living in the Netherlands, attended the divorce hearing, her family, who had come all the way from Turkey, were waiting for her and forced her to return with them to Turkey.¹⁴

According to Meeker, a Turkish husband cannot send his wife back to her parents because her *namus* is sullied; a woman's *namus* is her husband's sole responsibility after marriage. In Arabic culture, however, men may send their wives back as a woman's parents and brothers retain responsibility for her *namus*. A Turkish husband who attempts this will be threatened with violence: 'Among Arabs [...] if his wife is disgraced, he can send her back to her brothers and divorce her, sacrificing the brideprice. Among Turks [...] if his wife is disgraced, he cannot send her back to her natal kin unavenged without the threat of violence.'¹⁵ This finding does not apply to all Turks, however. Meeker conducted his research in Of, a district of Trabzon in the eastern Black Sea region. What it does reveal is regional differences in attitudes towards *namus*.¹⁶

Divorce

Divorce is one way of resolving a question of honour. However, some Turkish men continue to perceive their wife as part of their *namus* after the divorce. For these men, divorce is not a satisfactory solution if their ex-wife continues with her relationship. They demand that she end her relationship with her boyfriend. In the Ayanoğlu case study, however, the wife had no intention of doing so, and Ayanoğlu ended by killing her boyfriend.

Namus is sometimes purified by means of a temporary separation. Yeşilgöz and Coenen cite the example of Altan Erbulak, a well-known actor. When Füsün, his wife, committed adultery, he was compelled to take action under pressure from public opinion. The adultery had become public knowledge after Füsün wrote a book on the subject. Altan Erbulak divorced her, but remarried her a short time later, which seems to have been enough to restore his *namus*, certainly in the urban Turkish circles in which they moved.¹⁷ I should point out that divorce is not common in Turkey. In 1994, the incidence of divorce was 0.5 per thousand, giving Turkey one of the lowest divorce rates in the world.¹⁸

Disowning

A man may disown his wife.¹⁹ This is more drastic than a divorce as it means that he desires no further contact with her and no longer wants responsibility for her conduct. A woman's blood relatives may also disown her. Parents may disown a married or unmarried daughter, which means that she no longer exists for them or for her brothers and sisters, and can no longer injure the family's *namus*, provided she keeps out of their lives altogether. Disowning a daughter is called *evlatlıktan reddetmek* in Turkish (literally: rejecting descendancy) and occurs by means of a curse (*lânetlemek*).²⁰

In the Bitlis 4 case study, the girl was disowned by her parents following an elopement. In such a case, the girl is at the complete mercy of her boyfriend's family; if treated badly, she cannot return to her parents. Nor can she threaten to do so in the hope that her new in-laws will treat her better.²¹ This increases the power that her husband and his parents have over her. The situation is even worse for girls who cannot marry after being disowned, especially if they are pregnant.²²

In the Elmas case study, Ayşe's father tells Jan, her Dutch boyfriend, that he had burnt all of Ayşe's clothes. It later emerges that this is not true; he had put them in the attic. We do not know whether her father planned to disown Ayşe, or whether he only threatened to do so in the hope that she would return.

In the Türkmen case study, Emine, who had left her husband, Kaya, was disowned by both her husband and her parents. Just two months later, her husband remarried. His marriage to a widow took place in the mosque; a civil ceremony was not possible as the divorce

proceedings were not yet complete. The expert witness in this case could find no explanation for this rapid marriage; it was 'strange'. I believe that Kaya wanted to demonstrate with this marriage that his disownment of his wife was absolute; this was his way of resolving the question of honour.

The Türkmen case study shows that disownment is only effective if the woman remains 'dead' to the family. If she makes a reappearance (in this case she abducted her children), the remedy of disownment has not been sufficient, and social death may be followed by physical death.

Events may take a different turn, as in the 'Euphrates' case study. The girl survived the attack on her life and fled to the police. After the failed honour killing, her father decided to disown her and he informed the newspaper reporter: '*Kızım artık bizim ailede lanetlendi. Bizden uzaklaşsın*' (Our daughter is damned in our family from this moment. She must stay away from us).²³ We also encounter a disownment in the following case study:

The daughter of Abdullah, a Turkish man living in the Netherlands, left home to live with her boyfriend. When Abdullah and his brother are wallpapering our house, I cautiously ask him how his daughter is. He shrugs his shoulders and says nothing. Only when prompted by his brother is he prepared to say something. "*Kız benim için öldü*" (My daughter is dead to me), he says. It turns out that he has disowned her. He was furious with his daughter because she ran away two weeks before her wedding, which was to take place in Turkey. He had already bought plane tickets for the entire family, and his daughter and her fiancé had celebrated the civil wedding. His daughter now lives with her boyfriend. I enquire whether it might not be an acceptable solution for him if his daughter were to marry her boyfriend. He says it would make no difference. She is dead as far as he is concerned, and will remain so. Despite the disownment, Abdullah still talks about honour killing. "If you drive through a red light, you are fined," he says. When I ask him what he means by that, he makes a gesture of wringing someone's neck. When I ask who will be killed, he says: "Both of them." I wonder whether he is really contemplating honour killing, or whether this threat is his way of showing total disapproval.

Suicide

Sedat Türkmen, who came to the Netherlands to kill his sister, said: “Emine knew that she had to die. There was only one solution: she should have hung herself. She didn’t even have any *şeref* left. I rang her once and said: ‘In my eyes you are already dead.’ She started laughing loudly as though she was unaware of what was going on. She deserved to die 500 percent.” By *şeref*, Sedat was probably referring to his sister’s sense of self-worth. If she had had any self-respect, she would have committed suicide and would not have left it to someone else to kill her.²⁴ Here suicide is viewed as something positive and as an alternative to honour killing. By committing suicide, a woman shows that she is ashamed and no longer wishes to live.²⁵ The Bitlis 1 case study, in which a woman committed suicide after being raped by bandits, deals with this issue. Her father-in-law tried to stop her, saying that it was not her fault, but she no longer dared face other people and therefore had no desire to live.

However, a woman’s suicide is not always interpreted as a sign of shame; it may be perceived as the opposite – a sign of shamelessness. A girl may commit suicide because she is determined to have her own way and not marry the man chosen for her. If the suicide attempt fails, an honour killing may follow, as happened in the Elmas and Gürsel case studies, which are discussed in 7.6.

Men may also commit suicide if involved in a matter of honour. In the Barut case study, Şaban attempted suicide – and was rescued just in time – when he discovered that his wife had been raped by her cousin before their marriage. In the Ayanoğlu case study, Ayanoğlu threatened to commit suicide, hoping in this way to make his wife end her relationship with her boyfriend. If a man commits suicide, however, this is never viewed as a means of purifying *namus*. The *Hürriyet* reports of a father who could not bear his daughter’s elopement and who committed suicide: ‘Kaya (41), owner of a clothing factory, was so upset when his daughter, Serap, ran away to her lover that he committed suicide by shooting himself in the temple.’ The article reveals that it was not his *namus* that was at issue – this had been purified by the subsequent wedding – but his *şeref*: ‘Kaya’nın yakınları, altı ay önce sevgilisine kaçan kızının, gizlice evlenmesini gurur meselesi yaptı (Kaya’s friends said that he made a *şeref* issue (*gurur meselesi*) of the fact that his daughter had run off to her lover six months ago and had married him in secret).²⁶

6.2. No action

Behaving as though nothing has happened

An alternative response is to act as though nothing has happened. Gilsenan, who conducted research in northern Lebanon, cites the following example. Upon coming home, a man noticed – through a combination of intuition and clues – that his wife was having an affair with someone else. The other man was a well-respected, assertive individual with many brothers and other male relatives. Killing him would undoubtedly give rise to problems. Another option – for the husband to leave the village – would entail leaving behind his entire social world. Instead, the husband deliberately chose to visit the man frequently and to praise him in public. He threw himself with enthusiasm into the role of good friend. His relatives joined in the game, and the loss of honour never became public knowledge.²⁷

We encounter this option in the honour killing case studies as well. Utlu, from the ‘Death on the phone’ study, found out about Çiğdem’s relationship with Osman. Çiğdem undertook to end the relationship so that the couple could make a fresh start. “But,” Utlu said, “if the Turks had got wind of the affair, it would have been impossible for me to forgive her sin.” It later emerged that others did know about the affair, but that Utlu was not aware of this.

Girls who have been raped or are victims of incest may adopt this alternative, not only because they are too ashamed to tell anyone, but to protect male members of their family. If a woman admits to having been molested or raped, she is in effect forcing her male relatives to purify her *namus*.²⁸ A Dutch woman married to a Turkish man once said: “Things happen behind Dad’s back in many Turkish families. I didn’t want that to happen. I have always told my children: ‘He is your father. There’s no need to keep things from him.’”²⁹ The function of not telling has escaped her. Often the man plays along, pretending that he is ignorant of certain things.

Such avoidance behaviour is often expected of fathers. Petersen writes that, in the Turkish village where she conducted her research, it was a public secret that, before marriage, young people would meet covertly at the well or in town to talk and embrace. The father’s temperament dictated what he should do if he encountered his daughter there. Petersen was told: ‘Gute Väter würden “hurstend und

schnupfend" (*aksürür öksürür*) näherkommen, um die jungen Leute zu warnen; nur "schlechte Väter" würden sofort zuschlagen [...].³⁰

Rationalising

One way of dealing with loss of *namus* is to rationalise it in such a way as to redefine the problem. A story was told to me of Nezihe, a Turkish girl who came to the Netherlands to be married. The marriage soon ended in divorce. Nezihe stayed in the Netherlands and moved in with her boyfriend. Her parents and brothers viewed her as a Dutch girl, which meant that their own norms relating to *namus* need no longer apply to her.

Şengül, from the 'Stones in the garden' case study, took his wife back after she had eloped with Çağman, her lover. His wife and her lover were headed for the Netherlands but had been detained by the Turkish police for adultery. Şengül told her that, because he was seriously ill, he was already a 'dead' man, and he asked her to stay with the children. After the honour killing, he explained to the police why he opted for this alternative at the time: 'By that, I meant that I could no longer find a new mother for my children. So I didn't have to think about a new marriage. My wife agreed and came back home with me. I gave her a roof over her head once again and she stayed with the children.' Here, the husband rationalises the incident in such a way as to view his wife solely as 'the mother of his children', thus allowing him to keep his wife with him.

A family may also deny the fact that loss of *namus* has occurred.³¹ According to Pitt-Rivers, a man determines to a certain extent himself whether or not his honour has been violated: "If a man sees no insult and can be justified in seeing none, then his honour is not jeopardized. Hence the possibility of 'turning a blind eye.'"³² Schiffauer gives an example to illustrate how such an interpretation is possible. Mahiye's father allowed the young man, Ali, to stay in their house because he was keen for his daughter to marry him. Mahiye said that after the visit she had no option but to marry Ali; otherwise, she would have had to put up with rumours for the rest of her life that she had not entered marriage a virgin. According to Schiffauer, however, the visit by Ali did not have to be interpreted in this way. Much depends on a man's power and influence, on whether he can impose his own interpretation on the community.³³ Starr, who is of the same view, concludes: 'Events occurring in every-

day life have little meaning until they are interpreted by the actors and audiences involved in them, but credibility of persons, especially persons in authority positions, carries more weight than the credibility of less powerful persons.³⁴

Good and bad reputations tend to be reinforced. Someone from a family with impeccable *namus* can more readily convince the community of their interpretation than someone from a family whose *namus* is in question. Thus, a girl from a family with a spotless reputation may get away with behaviour that, for another girl, would arouse the suspicion of Turkish acquaintances. For instance, she may study and board in another city, without this posing a problem for her and her parents. She would of course come home dutifully every weekend. At the wedding of one such girl (she was the last of four children to marry and had boarded for several years), her mother said to me: "Now all my children have left home." She still saw her daughter as living at home until her marriage. Here too we can speak of an interpretation. The daughter had not left home; she simply spent a few nights a week elsewhere for her studies.

According to Gilsenan, 'declaring someone to be mad' is also a form of rationalisation.³⁵ A person who is quick to turn any issue into a question of honour poses a threat to the rest of the family. The family is then compelled to view matters as questions of honour that otherwise would never have assumed such proportions. One solution is to label such people as 'mad' so that no response is required to what they say or do. In my research, I did not encounter this solution with regard to relatives, but only in a more general sense. In the Ercan case study, for example, it was generally felt that Dayroğlu's sexual insults should not be taken seriously.

Acceptance

Economic considerations may cause people to accept the injury to their *namus*. They are unlikely to take action if the disadvantages resulting from restoring *namus* outweigh the benefits to be gained from this restoration.³⁶ Such a summation of the pros and cons occurred in a case brought to my attention. The incident took place in Tarsus, in İçel Province in southern Turkey, in the 1970s.

CASE STUDY: 'THE HEN WITH THE GOLDEN EGGS' (1970S)

A widow with two young adult sons became acquainted with a man whom she then began to meet regularly. When the affair became public knowledge, members of her family discussed whether the sons should kill the man. They decided that it was not a good idea because the man was rich. Thanks to him, the two sons were able to pay for their university studies. With the family's approval, they turned a blind eye to the relationship. The man was called 'altrn yumurtlayan tavuk', the hen with the golden eggs.

Blok describes a similar example in Sicily: the brothers-in-law of an adulterous woman did not kill her lover because he was their employer on whom they depended for their livelihood. They were called 'men with golden horns'; in other words, they were cuckolded, but benefitted from it at the same time.³⁷

6.3. Minimum response

A request to stop

Sometimes the male transgressor is asked to stop, as in the incident cited by Starr. When Güneş discovered that his wife was having a relationship with Sümer, he went to speak to the young man's father, who promised to warn his son.³⁸ In the Şengül case study, the entire Şengül family begged Çağman many times to leave Mrs Şengül alone. In the Elmas case study, Ayşe, the girl being talked about, was asked to stop. Elmas, at the end of his tether, even offered his daughter a house in Turkey, provided she put an end to her affair and marry her Turkish fiancé.

Küs (avoiding)

Küs means avoiding, keeping out of one another's way. It is used in the event of differences that cannot be resolved because both parties refuse to budge. Often, these disputes involve land, money or an inheritance. The word *küs* is also used in jest. If someone is slow to pay a visit, people ask: '*Küs müyüz?*' (Are we *küs*?) *Küs* is customary in blood feuds too. Although peace is not made, a truce is called in the

murders on both sides, and both parties keep out of each other's way. The feud is only re-ignited if there is cause; otherwise it is eventually forgotten about.³⁹

In the above example from Starr, we encounter an example of *küs* as an alternative to honour killing. Sümer, who visited Fitice in secret, and Güneş, Fitice's husband, no longer spoke to or looked at one another. This was effective because, as Starr writes: 'In time, everyone lost interest in what had happened, ' and an escalation of the question of honour was thus avoided.⁴⁰

An appeal to Islam: reconciliation

Islam can put a check on the particularism of honour, writes Schiffauer.⁴¹ Religious arguments may be the only ones to dissuade someone from acting on a question of honour. The religious festivals of Idul-Fitr (Şeker Bayramı) and the Feast of Sacrifice (Kurban Bayramı) are times when matters of *küs* are customarily ended. But does this apply to situations in which *namus* is involved? The Alawites have the *cem* – an informal meeting where justice is meted out. Reconciliations take place here, and this may be the occasion when questions of honour are peacefully resolved. Kressel encountered religious purification as an option: a sheikh proclaimed that a woman guilty of adultery was innocent, thus saving her from death.⁴² Breteau mentions hiding in a church or mosque to postpone an honour killing,⁴³ which may, as in *küs* situations, lead to the honour killing being abandoned.

Wanting an apology

In some instances, the honour killer questions the victim beforehand to confirm that the victim deserves to be killed. I believe that in such cases, the male transgressor and the woman being gossiped about could avoid being killed if they offered an apology.⁴⁴ In the 'Summer camp' case study, Çetin said that he telephoned the man who had violated his sister's honour to ask him why he had done it. According to Çetin, it was after the arrogant reply ('What business is it of yours?' or words to that effect) that he began making preparations for the honour killing. Mehmet Dursun also questioned Zeynep shortly before the killing. Zeynep claimed that it was her

right to have a relationship because, as she told Mehmet, her husband also had someone else. "I can kill her alright," Mehmet then said to his wife/ex-wife, Nimet.

Making a scene

Tacit acceptance of *namus* violation can be very dangerous. If the community comes to hear about it, the man is then perceived as a weakling who allowed the incident to happen. If there is a risk that the outside world will find out, it is better for him to make a scene immediately, to demonstrate to everyone that he does not condone the situation. In the Yiğit case study, however, this did not turn out well. By making such a fuss about his daughter being in the company of the boy next door, Yiğit caused the incident to escalate into a question of honour.

For women too, it is better to make a scene if they suspect that keeping quiet about their loss of *namus* will not work. After all, if the incident leaks out, they can be accused of being a voluntary party. Deug cites an example in which a Turkish girl, at her mother's insistence, initiated legal proceedings against her father for incest: 'She thought I should report it to the police. The community already knew about it and if he didn't go to prison, people wouldn't have believed what he'd done.'⁴⁵

Causing a scene can also function as an alternative to blood revenge. Hostilities are then maintained for a lengthy period, or permanently. The community where the man lives is fully aware that it will come to nothing, but they play along with it so that he does not lose face. Gilsenan gives the example of two brothers, who by rights, should have committed blood revenge. Each behaves very differently. "The elder [brother] always carries a gun very openly and is treated with great courtesy and etiquette of social place [...]. The younger brother, an army corporal who is seldom in the village, is quiet [...]. It is of him that men say the killer is frightened: 'Why? Because he says nothing and silence frightens.'⁴⁶ By adopting a clear stance, the elder brother demonstrated that this was his way of dealing with the situation. Because the younger brother's behaviour was more difficult to place, he was suspected of plotting blood revenge.

Threats

Often, the primary reason for threatening a woman or girl with honour killing or other consequences is to set her back on the right path. In the Tekin case study, the father threatened his daughter with honour killing, perhaps hoping that fear would drive her back home. In the Gürsel case study, the threats were effective for Fatma's older sister. When she threatened to go astray, her eldest brother went looking for her with a loaded gun, after which she came back home to live.⁴⁷ And in the Elmas case study, the father hoped that threats would bring his daughter back. Only when these proved ineffective did the family resort to an honour killing. Threats may also be directed at the male transgressor. In the Altuğ case study, the father wrote a threatening letter to Kalkan, in which he said he would kill him if he did not marry Mihriban, Altuğ's daughter. The purpose of threats is to put a stop to dishonourable conduct. They may also serve to show the outside world that those involved do not condone the injury to their *namus*.⁴⁸

Physical punishment

If a woman commits adultery, her husband may beat her in the hope that she will stop. Kemal Dursun tried this remedy in the 'Cassette tapes' case study, but it failed: Zeynep Dursun reported the assault to the police and fled to a women's refuge. One extreme form of physical punishment is mutilation. In the Biber case study, Biber ordered his son, Mevlüt, to disfigure his mother with battery acid. His son had reservations: "Even if she is disfigured, she can still go with other men." He also felt that the acid was not strong enough, so they tested it by throwing a piece of beef into the toilet bowl and pouring acid over it. Mevlüt said: "The meat began to smoke and disintegrate. I was able to mince it up with a fork from the kitchen."

Another form of mutilation is cutting off the nose of the dishonourable woman,⁴⁹ which is what a man did to his wife in the Bitlis 2 case study. The *Hürriyet* reports an incident in which a man, believing his wife to be unfaithful, cut off her nose in a fit of jealousy.⁵⁰ Durham, who conducted research in the Balkans, writes that cutting off the nose of an unfaithful woman was a customary practice in the past. Her informant claimed that it was the best way of ensuring that the wife would never again make love to someone else.⁵¹ It appears

that the man remained married to his wife and that the sole purpose of the mutilation was to ensure that she was never unfaithful again. Mevlüt Biber's statement reveals that his father had something similar in mind: 'Father then said that he wanted mother to be seriously wounded in her vagina. He said that he would then take mother back and take loving care of her.' This form of mutilation is not an isolated case. We encounter it in the Ottoman Criminal Code, the penal code that applied in Turkey before the founding of the Republic of Turkey in 1923.⁵²

Shaving the head of a woman who has committed adultery can be viewed as a type of mutilation.⁵³ This is a severe measure in terms of Turkish village culture, as tradition demands that a woman's hair never be cut.⁵⁴ Kressel mentions another sort of mutilation: severing the tendon on the right foot of a 'dishonourable' woman appears to be customary among Arab Muslims in Israel.⁵⁵

The male transgressor may also be the victim of mutilation. In Izmit, a boy who dared to elope had his ear cut off by the girl's brother.⁵⁶ In the Gürsel case study, Fatma, the girl who ran away, wrote in her suicide note to her boyfriend, Mustafa: "My family said I had to poison you or pour boiling water over you. I didn't have to kill you, injuring you was enough for them. That's what they said, and that they would then have protected me, that I would have purified my *namus*. But I couldn't do it. I couldn't betray you. I loved you. I was prepared to put up with anything [...]." An elopement looks like an abduction to the outside world if the girl is the one who inflicts the mutilation: after all, a girl would not treat her boyfriend in that way.

A sum of money

In theory, it is not possible to buy off an honour killing. Bourdieu writes: 'The Kabyles deride the attitude of the nouveau riche, ignorant of the rules of honour, who, trying to redress a slur on his *hurma* [*namus*], riposted by challenging his adversary to beat him in a race or spread out more than 5,000 franc notes on the ground. He was confusing two totally unrelated orders: the order of the challenge, and the order of the offence in which the most sacred values are involved.' Nor does the payment of money prevent blood revenge among the Kabyles.⁵⁷ However, among Turks, this does occur. Van der Molen mentions a sum of 40,000 guilders in *diyyet* (blood money) to buy off blood revenge. According to Van der Molen, Turks

may also resolve questions of honour through payment.⁵⁸ Durham too mentions fines as a means of paying off an honour killing. If a man makes a woman or girl pregnant and refuses to marry her, he must pay 130 talers for the child's upbringing. If he raises the child himself, he is not required to pay anything.⁵⁹ Ginat cites an honour incident in which money was used in an attempt to resolve the issue. When a girl was seen in the company of a young man, the girl's family demanded compensation from him.⁶⁰

In my research, I only encountered a single instance (the Köksal case study) of a proposal for money to be paid. The newly-wed Ebru was pregnant by her boyfriend, Hikmet. Ebru's mother told Hüseyin, Hikmet's older brother, that the injury to Ebru's *namus* would be forgiven if he paid 10,000 guilders. Hüseyin refused. We can understand why Ebru's parents made the suggestion: they needed money for an abortion. They were unable to pay for one themselves, as Aslantaş, Ebru's father, had been unemployed for many years and Ebru's wedding had cost him a fortune. I believe that the Aslantaş family may not have resorted to an honour killing if the money had been paid. Payment is also a way of offering an apology. Through their flat refusal, Hikmet and his family were laying all the blame for the pregnancy at Ebru's door.

6.4. Withdrawal

The honour violator withdraws

In Ginat's case study II, we encounter an instance of the male transgressor being made to withdraw. A father, whose daughter was having a relationship with a farmer, made sure that the farmer left the village.⁶¹ Durham reports that banishing the male transgressor was a penalty imposed by customary law in Montenegro.⁶² In the Şengül case study, the community felt that Çağman should leave Gaziantep. He went to live in Ankara with his family, although he later returned.

In some cases, it may suffice if the honour violator disappears for a time until things calm down. In the incident from Starr mentioned earlier, Güneş initially wanted to call Sümer angrily to account, but Sümer was nowhere to be found.⁶³

The family withdraws

In the Bitlis 2 case study, the husband withdrew after his wife had behaved dishonourably. Bourdieu also mentions this alternative, pointing out that people should either commit an honour killing or withdraw.⁶⁴ In the Şengül case study, the entire family migrated to the Netherlands to be free of Çağman, the male transgressor. In the Türkmen case study too, the husband brought his wife and children to the Netherlands in order to put an end to his wife's extra-marital affair. Akkaya, from the case study entitled, 'The young couple moves in with the parents', was later asked if there had been an alternative to honour killing. He replied: "Moving with my whole family, leaving town." In the Altuğ case study, the father wanted to leave the Netherlands immediately with his whole family after his daughter had become the subject of scandal, but this was not possible. Altuğ said: "I had run up quite a few debts when I bought a nut plantation in Turkey. I built it up for my family. I planned to return to Turkey for good in the summer. Then I would also be free of all the gossip about my daughter. I had told my sons this. They agreed to work very hard so that we could pay off the debts as quickly as possible."

6.5. Calling in the authorities

The police bring the daughter back

In Turkey, fathers who are adamantly opposed to their daughter's elopement may have her brought home by the police if she is a minor. The police are expected to deliver an under-age daughter unconditionally to her parents. If she is no longer a minor, the police check whether she eloped or was abducted. If it emerges that she is with her boyfriend of her own free will, the police negotiate with the father to see whether he will agree to a marriage. For this reason, many girls – including those living in the Netherlands – wait until they are eighteen before embarking on an elopement (see the Ardal case study). In the Sefiye, Asiye and Türkay elopement incidents, which took place in the Netherlands, the parents called in the police to bring back their under-age daughters. But parents are then saddled with a daughter who has a stain upon her *namus*, and they must find another solution. In the Asiye case study, they opted to move away.

Asiye and her mother went to Turkey, while her father looked for a house in another town in the Netherlands.

As a rule, if the girl who elopes and is then brought back is already promised (*sözlü*) or engaged (*nişanlı*) to another young man, his family will no longer want her. In the village of Yaycıabdal köyü, in Amasya District in Amasya Province, the prospective in-laws were still very keen to have the bride-to-be, even though she had eloped with someone else. I suspect there was a shortage of girls in the village. So that they will not be required to do the hard work in the village, most girls are married off to former villagers who have moved to the city, leaving too few marriageable girls for the boys who stay behind. This may explain why families do not wish to give up a girl who has been promised to them.

Having a daughter brought back is not without its risks. Her boyfriend and his family may be so offended at losing the girl that they provoke and threaten the girl's family. In the Şener case study, this went so far that the boyfriend eventually killed the girl's father.

THE ŞENER CASE STUDY: 'THE POLICE BRING THE DAUGHTER HOME'
(1977)

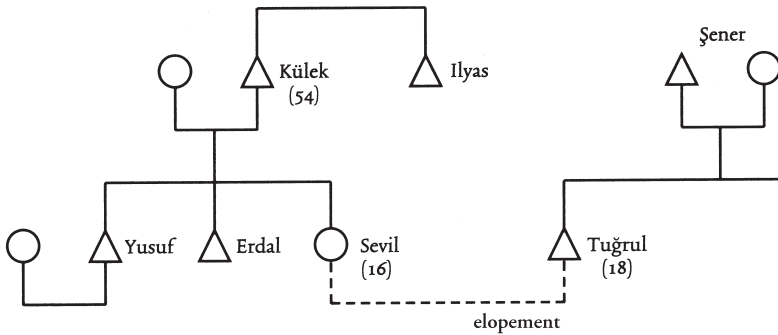

Fig. II: The Şener case study

Külek, born in a village in Central Anatolia in 1923, is an agricultural labourer in Turkey, where his family lives in poverty. In 1961, Külek comes to the Netherlands. In 1968, at work, he becomes acquainted with his compatriot, Şener, who has just arrived from Turkey. For a time, they live in the same boarding house. "We became very good friends," Şener says later. In

1972, both Şener and Külek have their families brought over to the Netherlands. The two families visit one another. Tuğrul, Şener's 18-year-old eldest son, has his eye on Sevil, Külek's youngest daughter, who is sixteen. In mid-November 1976, Şener comes to hear of this. He and his wife immediately go to ask Külek for Sevil's hand. Külek refuses, which surprises Şener. After all, they have been close friends for eight years now. When Şener tells his son about the refusal, Tuğrul and Sevil decide to run away together. Tuğrul collects Sevil one afternoon from sewing school and they go straight to his parents' home. That same day, Külek comes to their house. Nobody opens the door. The next day, the juvenile police come to the door to find out whether Sevil is there. Şener lies and says that she is not.

A week later, a meeting is arranged between the two families, held at the Küleks' home. Uncle Ilyas, Külek's brother, is also present. Şener lies to Külek, telling him that his daughter is in Germany with relatives of theirs. Külek asks for the exorbitantly high brideprice of 40,000 guilders. A Turkish mediator helps to bring the amount down to 25,000 guilders.

Three weeks later, Külek discovers that his daughter is at the Şener's house after all. He calls in the juvenile police to mediate. It is agreed that Sevil will be returned to her father and will live with Yusuf, her eldest brother, who is married, until her marriage to Tuğrul. Tuğrul will be allowed to visit Sevil each day. The police fetch Sevil from the Şener's house.

Once Sevil is back with her family, however, Külek does not keep to his part of the agreement. He puts his daughter and his wife straight on a plane to Turkey. As soon as Tuğrul finds out, he starts harassing the Küleks; he even threatens to shoot them all. The Küleks report the threat to the police. They had already decided, because of their daughter's affair, to return to Turkey for good, but after Tuğrul's threats and intimidation, they decide to hasten their return. In early January 1977, Külek and his two sons, Yusuf and Erdal, load their household goods into two vans they have bought especially for their return. Uncle Ilyas is there too. Tuğrul Şener suddenly appears with a gun in each hand, shouting: 'I'll shoot you all.' He fires at the men. Külek falls to the ground. His son Yusuf then attacks Tuğrul. Tuğrul fires at Yusuf, who starts bleeding. Erdal and Uncle Ilyas rush to Yusuf's assistance. A deadly fight ensues on the street as the three men try to wrest the guns from Tuğrul. They succeed. As he struggles to escape, they tie Tuğrul up with a rope so that they can hand him over to the police. Tuğrul shouts that he has shot their father. Erdal goes to look. He sees his father lying between the vans. He is dead. Erdal then grabs the pistol from his father's pocket, runs back to Tuğrul and shoots him in the head.

The court finds Erdal Külek guilty of killing Tuğrul Şener. However, they declare that he cannot be penalised given his state of mind when he found

his father dead, and they dismiss all charges against him. The court orders his immediate release.

Külek's killing is a matter of injured *şeref*: Tuğrul Şener's prestige had suffered as a result of the failed elopement. Tuğrul could not accept that Sevil's father, with the help of the police, had taken Sevil back. Instead of honouring the agreement that Tuğrul could continue to see Sevil, the family had taken her to Turkey. Tuğrul then began, perhaps with his father's blessing, to provoke and harass the Küleks, eventually going so far as to shoot and kill Külek. I would call this 'murder/ manslaughter for reasons of male pride'. The subsequent killing of Tuğrul by Külek's son, Erdal, can be seen as immediate blood revenge. Tuğrul Şener was killed because he had killed a member of the Külek family.

Lawsuits

Pitt-Rivers does not view a court case as a means of purifying *namus*; on the contrary, it only aggravates the question of honour because of the publicity it generates.⁶⁵ Schiffauer, on the other hand, notes the pragmatic approach of villagers to the courts during his research in a village in the Black Sea region. If it suited their purpose better not to resolve the question of honour themselves, they would call in the courts to assist. He cites the example of a family who did not wish to commit an honour killing because their son, who would then have to spend time in prison, could not be spared on the farm. In practice, however, the courts were located too far away to be effective.⁶⁶

Common lawsuits with regard to *namus* are cases that involve adultery (*zina davası*), abduction (*istenmeyen kız kaçırma*) and rape (*ırzına geçme davası*).

Adultery

In the 'Stones in the garden' case study, Şengül was asked, once the police had picked up Mrs. Şengül and her lover, whether he wished to take the matter to court. It was still possible at that time to initiate criminal proceedings for adultery (*zina davası*). Both the spouse and the lover could be sentenced to prison. Women who were subsequently taken back by their husbands had no rights; instead, they had

to be grateful to the husbands for wanting them back. In the journal *Nokta*, the Turkish woman A. Ç. describes what happened after she had been caught in the act of adultery: 'I spent two months at a remand centre. Then my husband and I made peace with one another. He decided not to prosecute. I am still married to him. My husband says that he has forgotten about it and that I should forget too. But I can't. Your husband might forgive you, but your parents, members of your family, they don't. My husband is now free to do entirely as he pleases. I can't do anything about it.'⁶⁷

Such a situation arises if a woman is financially dependent on her husband. In Turkey, a woman's sole option in many cases is to return to her parents. In many countries, criminal prosecution for adultery has long been abolished.⁶⁸ A couple may separate but they cannot prosecute one another in court. In an article in *Nokta*, the Turkish criminologist, Sulhi Dönmezer, argued that criminal prosecutions for adultery should be retained in Turkey, a stance that he also defended at international congresses. He maintained that adultery lawsuits prevented honour killings. "People take adultery far less seriously than they used to," he said, "but the Turkish husband who has been cheated on still wants punishment. Lawsuits of this kind provide an effective safety valve." Dönmezer ended his plea by saying: "But perhaps Turkey will demonstrate in the future that it has become civilised enough to abolish adultery as a punishable offence from its Criminal Code, and to simply make it grounds for divorce."⁶⁹ This finally happened in 1999.⁷⁰

Abduction

Although parents often agree to a marriage following an elopement, if they are truly opposed to the marriage, they can lodge a complaint (*şikayet*) against the young man who eloped with their daughter. The case against him is then set in motion. The judge is confronted with the problem of deciding whether or not the girl is telling the truth. To prevent a scandal for herself and her family, she will claim that she was abducted. If the man involved is unable to repudiate the 'abduction' claim, he risks a prison sentence. What sometimes saves him is an old photo showing him and the girl together, evidence that he is her boyfriend. In the Uzun case study, Uzun's younger brother wrote to him from Turkey telling him not to commit an honour killing but to initiate court proceedings on the grounds that his daugh-

ter, who was already legally married in Turkey, had been abducted. The letter said: "In Turkey, the penalty for abducting a married woman is seven or more years in prison. You have to take the matter to court [...]. Put those crazy ideas out of your head. You still have other children and a wife. Follow the rule of law."⁷¹

For the girl's parents, a court case may be a means of forcing the boy into marriage. If he does not marry their daughter, he will go to prison, which is what happened in the 'Denmark' case study. Resul lodged a complaint against Fevzi, who had abducted his daughter, Songül. Resul wanted Fevzi to marry Songül, but Fevzi refused, despite the prospect of imprisonment. When Fevzi was sentenced to prison, it became difficult for Resul to kill him. It is quite likely that Resul did not consider honour killing at first, but pinned his hopes on marriage as an alternative means of purifying *namus*.

Rape

A court case may also be initiated for rape. This may involve a real incidence of rape, or a case in which the 'rapist' is actually the girl's boyfriend. An article in the *Hürriyet*⁷² describes how, when caught in the act with her boyfriend, the girl claimed in her defence that he had raped her. The girl's parents took Adem, the boyfriend, to court, where he was able to produce five love letters written by the girl. Her reply: 'I love Adem very much. I am prepared to marry him, but my family will not allow it.' Here we see the same types of motivation as with 'abductions'. The girl is obliged to say that she was raped to avoid being called *namussuz* (dishonourable). The article does not report who caught the girl – probably her parents, as she had invited the boyfriend to her home. I presume that the parents were also aware that it was not a question of rape, but that this was their way of venting their anger.

Mediation

Of itself, mediation is not an alternative to honour killing, but it is a means of arriving at a peaceful solution. In the case of elopements, it is customary for mediators to be brought in. The boy's family enlists the help of a man held in high regard by the girl's father. In the Balkans, Durham reports, the 'council of elders' acts as mediator. They

may choose to impose a fine.⁷³ In the Dursun case study, the mayor of the Dursuns' home village told the probation officer that questions of honour are usually resolved without violence that ends in death. Instead, the two village *imams*, members of the village council (*köy heyeti*) or other prominent villagers are called upon to mediate.⁷⁴ The mediators ensure that a peaceful solution, such as divorce, is negotiated. Kressel reports that, as a stranger, he was sometimes called in to mediate.⁷⁵

If the event of adultery, or a woman running away, the families of both spouses are the ones who mediate, often with the aim of patching up the relationship. In the Dursun case study, Serpil, Zeynep's sister, thought that Kemal should have rung his father-in-law, who was also his father's brother, to reach a joint decision about his wife's adultery. In the Bitlis 4 case study, a girl eloped, prompting her family to pick a fight with her boyfriend's family. Influential elders succeeded in reaching an agreement between the two families.

Sometimes the Dutch police are called in to mediate. In the Dursun case study, Zeynep Dursun and the wife of Ali Eralp, Zeynep's lover, took turns going to the local police station to tell their story to the neighbourhood police officer. He was unable to solve their problems, however. The same officer tried to mediate in the elopement in the Tekin case. He arranged meetings between the runaway couple and their families but here too was unable to prevent matters from escalating to an honour killing. Sometimes it is counter-productive to call in the police to mediate. Koparan, in the case study of that name, asked the neighbourhood police officer to intervene in a conflict between him and the Gürdal family. This only served to aggravate matters: Gürdal then accused Koparan of 'setting the police onto him' and stepped up his threats.

In some cases, it appears that Turks are afraid of becoming involved with families in their social circle who are implicated in a question of honour. In the Yiğit case study, people from the same village of origin but now living in the Netherlands did not attempt to mediate until three years after the question of honour first arose. Did they believe that the matter would blow over, or did they stay out of it because they did not wish, or dare, to become involved? In the Akkaya case study, we observe how Sedat Oğuz, who came to mediate when Akkaya wanted to evict his tenant, Faruk Taş, from his house, withdrew rapidly when he heard that a question of honour was involved. Later, Sedat Oğuz explained his behaviour as follows to the police: 'You have to understand that we are not supposed to be-

come involved in questions of honour. It's taboo.' He gave as a reason: 'Getting mixed up in a question of honour is tantamount to stirring up both sides against one another.' Perhaps he was afraid of being seen as the guilty party by both sides, and falling victim himself to an honour killing.

Even after an honour killing has been committed, Turkish acquaintances keep their distance. While on remand, Akkaya told Sedat Oğuz why he had committed the double murder. His friend kept quiet and did not comment because, as he told the police later, 'An honour killing is something you don't ask questions about.' When the murder of a young woman was being discussed on a current affairs programme on Turkish television,⁷⁶ several male eyewitnesses said: "We saw a man stab a young woman to death with a knife. We thought, he's either her father's brother, her brother or her husband [*ya amca oğlu, ya erkek kardeşi, ya kocası*]." Rather than intervene, they let the man continue. What their words imply is: "We didn't get involved because it was quite obviously an honour killing." For Turkish television viewers, there was no need to state this explicitly; the audience would have understood immediately.

Giving information about an honour killing to the police can also present problems. In the 'Knifing in the square' case study, which occurred in Urfa, many bystanders were present at the killing, but no one was prepared to say anything to the police. In the Elmas case study in the Netherlands, the police wished to interview people from the Turkish community in order to collect background information about the honour killer and his family. The court records report that 'many Turks seem too afraid to speak.'

Turks know that families are highly sensitive about their *namus*. It is understandable, though not, I believe, always desirable that they should wish to keep well clear of such matters. It is precisely because questions of honour should be prevented from escalating that mediation is so important.

Abandoning the baby

The alternative to killing a baby born out of wedlock is to abandon the child.⁷⁷ The customary place to do so is on the steps of a mosque. These children are then taken to a children's home, where attempts are made to find a foster family. Below are some examples from the *Hürriyet*:

(Iskenderun) The fifteen-year-old C.K., who gave birth to a child after a relationship with her cousin [amca ođlu], abandoned the child in the street. The one-day-old baby, who almost froze to death, was handed to the police by passers-by. When traced, the young mother told the police in tears that her family did not want her to marry her cousin and that she did not know what to do with the baby.⁷⁸

(Mudurnu, Karacasu köyü) H.Ç. and Mehmet Karayakalı were arrested for abandoning their baby. A shepherd had discovered a one-day-old baby in a cardboard box in the woods. It was revealed that the baby belonged to H.Ş. She said that she had become pregnant after being raped. Last month she married Mehmet. He knew what had happened and they both decided to abandon the baby. They were afraid of gossip. Both say they are sorry and want to raise the baby together.⁷⁹

It is quite likely that the baby was Mehmet's own child. However, a birth so soon after the wedding would have sparked gossip within the village.

(Erzurum) A one-month-old baby girl was found in a bag in the inner courtyard of a mosque. The baby's cries alerted people to her presence. The police took the baby to a children's home, where she has become the staff mascot. They call her Hülya.⁸⁰

This last article also revealed how frequently babies are abandoned:

Staff at the children's home said that seven babies had been abandoned in Erzurum over the past two months and they hope there is a family who will want to adopt Hülya.

In May 1999 in the Netherlands, the 22-year-old Turkish woman from the G. family gave birth to her baby on her own, and then abandoned the baby on the fire escape of her apartment building. The previous summer, she had become pregnant by her future husband, who was still living in Turkey. As they were not yet married, she did not dare tell anyone about the pregnancy. The matter came to light when she suffered severe haemorrhaging after the birth.⁸¹

6.6. Injuring the *namus* of the honour violator

The honour violator's wife

An unusual alternative is to violate the *namus* of the male transgressor. In the Çetin case study, Kalemli, the deceived husband, wanted to go to bed with the wife of Özbay, the man who had violated his wife's honour. Mrs. Kalemli described it as follows: 'My husband regarded sleeping with Özbay's wife as the only way to even things up.' Özbay and his wife found it a ridiculous proposal. Other Turks questioned by the police about the feasibility of this suggestion also thought it strange: "In our view, such a thing is impossible. We really had to laugh about it," replied one of them. We encounter a similar proposal in the Dursun case study. Mrs. Eralp, the wife of the male transgressor, was terrified that her husband would be killed. She therefore suggested that the Dursun brothers 'do it with her seventeen-year-old daughter'. The Dursun brothers told the police what their response had been: 'We did not wish to set honour against honour.'

This alternative was mentioned on one occasion in the *Hürriyet* newspaper, not as a 'deal' with the male transgressor, but as a trap: "In Salihli, the Elmacı's planned to avenge themselves against Aydın Aydın, who had raped Mrs. Elmacı five months previously. They invited Aydın Aydın and his wife Selda to eat with them. After the meal, Mrs. Elmacı aimed a rifle at Aydın while Elmacı tied him up. Elmacı then took Selda to the bedroom. Elmacı reappeared fifteen minutes later, saying: 'I have raped her and now I have my revenge [öcümü aldım].'"⁸²

After the deed, Ali Elmacı spoke of vengeance, rather than purifying his *namus*. Indeed, I do not believe that he could purify his *namus* in this way, although his action might be viewed as an adequate alternative to an honour killing.

Elopement

In the 'Denmark' case study, violation of *namus* prompted an abduction. The deceived husband, Fevzi Çağlar, abducted and deflowered his wife's 13-year-old sister, Songül Çağlar. After detaining her for several months, he took her back to her village. The people of Songül's village found it a very strange, unorthodox course of action.⁸³

7. Why an honour killing?

When studying court records of honour killings, we might easily conclude that loss of honour always ends in a killing. After all, that was the outcome of every question of honour in the court records. According to Gosewehr and Verheijden: “there is considerable pressure. People know and accept that the sanction for violating family honour is death.”¹ However, we should not lose sight of the fact that many a question of honour is resolved by peaceful means.²

People do not automatically resort to honour killing whenever *namus* is lost or at risk. In the nineteenth century, Westerners believed that there was no rule of law in non-Western societies. In the early twentieth century, when it became apparent that such rules did in fact exist, they made a volte-face and assumed that non-Westerners adhered to the rules rigidly. Malinowski took an opposing view, and warned against regarding people from other cultures as being totally obedient to the rules of the group.³ The fact that honour killing is a tradition in rural Turkish culture does not adequately explain its occurrence.

Transactionalism, a theoretical school of thought within cultural anthropology, has taken up Malinowski’s individualistic view of society. Transactionalists accord a key role to what is termed agency, or the individual’s capacity to take decisions. Structuralists, who adopted an opposing view, have tended to continue the nineteenth-century tradition. They believe that individuals think and act in accordance with the rules and norms dictated by their culture, and that agency plays a marginal role. Sherry Ortner, an anthropologist, adopts a position midway between these two schools of thought. Her assumption is that, although everyone has certain cultural schemas in their heads, not everyone deals with them in the same way or is influenced by them to the same extent. How they do so depends on personal circumstances.⁴ This intermediate position seems to me the most fruitful: on the one hand, honour killing cannot simply be dismissed as an aspect of Turkish culture in which people are compelled to seek refuge; on the other hand, honour killing does form part of the cultural heritage of the Turks who are the subject of this study. It is

something they cannot shake off, for the simple reason that they live in a society that attaches prime importance to female chastity.

If Turkish newspaper articles were our sole source of information on honour killings, we would learn little beyond the fact that the purpose of the killings was to purify *namus*. Reading these articles reinforces the notion that loss of honour irrevocably leads to honour killing. We learn nothing about the background to the question of honour, although this is the key to interpreting the killing.⁵ The existence of a *namus meselesi* (question of honour) alone must not be viewed as sufficient explanation for an honour killing. Ginat writes: 'Accusation and murder cannot be explained as normative behaviour alone.'⁶ He believes we should look into when loss of honour is followed by a killing and when it is not.⁷ Black-Michaud also emphasises the need for a study of this type, given that almost identical questions of honour can be resolved in very different ways.⁸

The previous chapter looked at several alternatives to honour killing that nevertheless failed in the instances discussed. Although such failure causes a question of honour to escalate, it is not the sole reason why a family ultimately opts for an honour killing. Kressel and Ginat, both of whom have looked into the question of when loss of honour leads to a killing, each cite a single factor that they view as decisive. In contrast, I have been able to identify eight groups of factors that make an honour killing more likely. The first group relates to pressure from the Turkish community; the second to ulterior motives for honour killing; the third to provocations; the fourth to specific characteristics of the honour killer or the accomplice; the fifth to elopements; the sixth to honour killings of a female family member; the seventh to contributing factors, such as the use of firearms and alcohol; and the eighth to the situation of immigrants. The first seven groups of factors apply to both Turkey and the Netherlands.

A question of honour, by definition, always affects a man's *şeref* to some degree because it shows that he cannot adequately protect and control the female members of his family. In the honour killing cases, however, *şeref* was violated to a very serious degree. The discussion below seeks to demonstrate how it was this fact that caused matters to escalate to an honour killing.

7.1. Pressure from the Turkish community

One of the factors that determine whether a question of honour leads to an honour killing is the relationship between Turks and their community. We should recall the discussion on this point in chapter one. With such close ties to their community, Turks find it intolerable to be socially excluded. A family whose *namus* is attacked is subject to pressure from members of their community, which is manifested in the following ways.

Extent of public knowledge

According to Kressel, whether or not an honour killing takes place largely depends on how many people know of the dishonour.⁹ The punishment for honour killing is not an indicator of the gravity of the violation itself, but rather of the extent to which it has been publicly disclosed.¹⁰ The more people who know about the loss of honour, the more likely the honour killing. Pitt-Rivers makes this same point: ‘There is no disagreement that the extent of the damage to reputation relates to the range of public opinion within which the damage is broadcast.’¹¹ Deug too observes an escalation as more people come to know about a girl’s elopement: ‘Public opinion weighs [...] very heavily. If the matter is not yet known, the family will usually want to settle it behind closed doors – and they can achieve this by arranging a marriage. If that is not possible, or if too many people know about it, the family’s honour is much more at stake.’¹²

There is a greater role for ‘quiet diplomacy’ if the loss of honour is not yet common knowledge. For example, a man may divorce his wife on the grounds of irreconcilable differences (*şiddetli geçimsizlik*); no one need know that the divorce was prompted by a question of honour. In the Tekin case study, Tekin was mortified when he discovered that his daughter Pınar’s elopement with her boyfriend Tavaslı was gradually becoming common knowledge within the Turkish community. The probation officer wrote: ‘The difficulties experienced by [Tekin’s] family had gradually become a *cause célèbre* in the Turkish community. It was inevitable that he would be subject to immense social pressure, which forced him, no matter what, to take Pınar away from Tavaslı.’ The belief that everyone was talking about him may have driven Tekin to resolve the question of honour

quickly. In the Ercan case study, the sexual insult was uttered in the presence of compatriots, which may have escalated matters.

In some cases, there is a more specific relationship between honour killing and public knowledge. What increases the likelihood of an honour killing is not the fact that the question of honour has become public knowledge, but that the honour killer-to-be and his family discover this to be the case. Hence the Turkish saying: '*Koca en son bilir*' (The husband is the last one to find out), referring to a wife's adultery. A husband knows that no one will pass information of this kind on to him. If he discovers that he has lost his *namus*, his first question is always: 'Who knows about it?'

Frequently, everyone except the members of the family concerned knows about the honour violation. We see this in several of the case studies. In the Köksal case, all the Turks at Ebru and Hikmet's workplace knew of their affair: photos were even taken of the couple on a work outing to an amusement park. Nevertheless, Ebru's parents were not informed. In the Uzun case study, the girl said that the women in the van were aware of her relationship with Makal. Her father, however, had no idea. In the Ayanoğlu case study, everyone at work knew that Mrs. Ayanoğlu had a lover, but her husband knew nothing. In the Şengül case study, in which Mrs. Şengül stayed behind in Turkey when her husband went to the Netherlands, the people in her street, at the very least, knew about her extra-marital affair. At one point, they threw stones into her garden, probably to show their disapproval of her lack of honour. However, when her husband returned on holiday in the summer, nobody told him how matters stood.

It is perhaps surprising, given the enormous social control that results when everyone knows everyone else's business, that extra-marital affairs can occur at all. This is because the man who has prime responsibility for the girl or woman is not informed. There are three possible explanations for why this happens. The first is fear of the consequences. Everyone knows just how serious the offence is and that an honour killing is always a possibility. Secondly, it is a way of protecting the husband. So long as he knows nothing, he need not take any action. Thirdly, nobody wants to be the bearer of bad tidings for fear of being blamed themselves. In the Utlü case study, Osman, the coffeehouse proprietor, took the deceived husband into his confidence. He told Utlü that he and others knew about his wife's adultery and the abortion, which enraged Utlü.

Direct confrontation with loss of namus

A man is only driven to action when directly confronted with the loss of his *namus*, as several cases demonstrate. Pitt-Rivers writes: 'A man was dishonoured only at the point where he was forced to realise that he had been, where his shame was brought home to him', and: 'The significance of the presence of a person is highly relevant to his honour. That which is an affront if said to his face may not dishonour if said behind his back. That which, if done in his presence, is offensive may not be so if he is not there to resent it. What is offensive is not the action itself but the act of obliging the offended one to witness it.'¹³

A man can ignore loss of honour until openly confronted with it, at which point he can overlook it no longer. In the Çetin case study, Kalemli had long harboured suspicions about his wife and his friend Özbay. But it was not until he and other families received a letter announcing that his wife and Özbay would be responsible for the meals at the summer camp that he began interrogating his wife.

In the Dursun case study, preparations for the honour killing began when the Dursun brothers had the cassette tapes in their possession. From that moment on, they could no longer pass off the loss of *namus* as gossip. However, this confrontation with loss of *namus* differs from that in the Çetin case study, which involved a direct public confrontation (the letter was widely distributed). The cassette tapes were not in general circulation, although the Dursun brothers feared that this might happen. A direct confrontation need not be public in order to produce a desperate response. On the subject of customary law in the Balkans, Durham writes that the husband may kill his wife and her lover on the spot if he catches them in the act of adultery.¹⁴ This does not apply to other forms of loss of *namus*. Similarly, the Turkish Criminal Code makes provision for a sentence reduction to one eighth of the customary sentence only if the victim is caught in the act of adultery or indecency. This suggests that direct confrontation is perceived as being particularly serious.¹⁵

Public accusation

According to Ginat, it is a public accusation that increases the risk of an honour killing, rather than the extent to which loss of *namus* is common knowledge: 'One common feature standing out in the case

histories and others not cited in this paper is that there is no murder without public accusation by an injured party.¹⁶ He takes up this point once again in response to Kressel, adding that the public accusation cannot be explained by the loss of honour alone. There is usually a personal motive: 'Several scholars have noted that public knowledge [...] leads to punishment [...]. My own research however, makes it clear that the murder [...] is carried out only when there is a public accusation. The reasons for public accusation by an injured party cannot be explained by normative behaviour alone. Usually, there is personal motivation and as often as not it is of a political character.'¹⁷

One example is the Yiğit case study. While on holiday in his native village, Yiğit caught his daughter Ayşe in the shed with the next-door neighbour, Ahmet Akan. He immediately made a proposal of marriage to the Akan family. When this was rejected, Yiğit threw a stone through their window, thus alerting the entire village to what had happened. With this – in effect – public accusation, Yiğit needlessly caused the situation to escalate. It is hard to imagine why he acted in this way. After all, fathers usually behave as though they are unaware of what is going on.¹⁸ My Turkish mother-in-law's explanation for Yiğit's behaviour was that he probably wanted his daughter to marry Ahmet Akan and that he saw the *namus* violation as a means of bringing this about. This would point to a personal motive for the public accusation of the kind Ginat encountered in his research.

The Barut case study also involved a public accusation, although Ertan claimed that this was unintentional. Ertan told his half-sister that he knew she had been sexually abused by her cousin. Unfortunately, her husband and the entire village came to hear of it. Ginat says of this type of accusation: 'Sometimes the accusation is neither politically motivated nor premeditated, but spontaneous – an outburst due to accumulated frustration and a sense of unbearable humiliation.'¹⁹

According to Ginat, public accusations that result from an outburst occur most commonly among women who are unaccustomed to reprimanding male members of their family but who cannot tolerate their situation any longer. In the case of Ertan Barut, who killed his cousin for reasons of honour, a consideration may have been his powerlessness for many years in the face of his much older cousin, which had prevented him from doing anything about his cousin's sexual abuse of his half-sister.

Isolation

Loss of *namus* may provoke ridicule or gossip. In the Şengül case study, Ibrahim went to the Turkish camp (a row of barracks inhabited by Turkish men) directly after the honour killing, where he was greeted derisively with the words: 'Is your mother sleeping with her boyfriend again?' Nobody knew that he had committed an honour killing yet. Sometimes a man whose *namus* has been violated no longer dares show his face in the community.²⁰ We find an example in the story *Reşo Ağa* by Bekir Yıldız, in which Reşo, a landowner, does not leave his house after his daughter is abducted. According to the written summary of argument in the Uzun case study, Habib – the honour killer and Meral's brother – was completely ignored by friends in his hometown in the Netherlands. This is confirmed in a letter his sister Meral wrote to her father: 'If you see me, don't say anything, just shoot me immediately [...]. Then our name will be purified [...]. There's been so much gossip about us that it's driving you crazy. I know what you're going through. Then everyone will be at peace and will treat you well once again. Do this ...'

In the Altuğ case study too, the 19-year-old honour killer dared not face anyone before the murder. He told the psychologist: 'I was terribly ashamed in front of all my friends because Hacı Kalkan had been to bed with my sister. I knew they'd ostracise me if I did nothing. I could always feel their mocking eyes looking at me.'

Ahmet Gürsel from the 'Discharged from hospital' case study was so affected by the fact that his sister had run away that he locked himself inside his parent's home. Tekin, the father in the Tekin case study, no longer dared show his face in public. Despite his title of *hacı* (earned by going to Mecca), he stopped going to the mosque. His statement to the police reads: 'I felt bad towards my 2, 500 compatriots here. It was extremely difficult. I was ashamed. I couldn't even go to the mosque any more [...]. I felt that I had been a bad father to Prnar and I felt bad towards my family.'

But the Turkish community did not shun Tekin. On the contrary, many people visited the family, probably to cheer them up, not comprehending why the daughter had run away. After all, she was just about to marry – something that she herself had desired. According to the written summary of argument, 'there was a daily invasion of people who tearfully expressed their sympathy and plied the family with all kinds of advice.' Tekin believed, however, that people soon started to gossip about the family behind their backs, and he no lon-

ger wished to see anyone. The written summary of argument stated: 'Tekin no longer dares show his face, no longer goes to the Turkish café and no longer dares look his neighbours in the eye.'²¹

Honour killings are committed to escape from this isolation. It is said that honour killers feel reborn after their deed. They have put an end to their social death and feel accepted once more by the community.²² Utlu experienced how an honour killing makes a person count for something again. He had had no contact with his parents for many years because they did not approve of his lifestyle (he was divorced and refused to marry his girlfriend). However, while on remand, he soon received a visit from his parents, who embraced him and took him back into the fold. Utlu himself was unhappy about this. He complained: 'They never wanted to see me again, but look, I murder someone and they come to congratulate me!' He had no wish to see his parents again. With some exceptions, honour killers are not seen as contemptible murderers but as people who were compelled to act in order to purify the family honour.

I was curious to know whether an honour killer acquires more *şeref* than others in the community, but Turks with whom I discussed this denied it. According to them, it is always best not to become involved in a question of honour in the first place. This seems logical; otherwise a man would be happy for his *namus* to be impugned as it then gives him a perfect opportunity to commit an honour killing and thus acquire *şeref*. An honour killing restores the *şeref* lost as a result of the question of honour, but it does not by definition raise the honour killer above others in the community. The Turkish word for 'hero' (*kahraman*) is not used for honour killers. Honour killers do, however, have high status in prison.²³ I also suspect that under-aged honour killers are virtually regarded as heroes. In the Şengül case study, the probation officer from the Child Welfare Council wrote with concern: 'The Turkish community views Ibrahim as a hero. They even want to raise money as a reward. If Ibrahim were sent to borstal, there would be a celebration whenever he was allowed home on the weekend and there is a great risk that this would harm him. The best solution seems to be to return him quietly to his family. The novelty will soon wear off.' In the Uzun case study too, it is reported that the Turkish community viewed the young Habib as a hero.

Incitement to honour killing

Gossip is not fatal, according to Ginat. He cites Malinowski: 'Public opinion will gossip, but not demand any harsh punishment.' (1926)²⁴ In the case of honour killings, however, it is common knowledge that people are sometimes incited to carry out the killing. This will enable them to escape their social isolation and participate once more in community life. In the Şengül case study, Ibrahim said that he was called into the coffeehouse, given tea, and urged to kill his mother's boyfriend. According to Ibrahim, a man at the coffeehouse spat right in his face.²⁵ In this case, we only have the honour killer's statement, which could not be verified by other witnesses. The court records do not contain more specific information about general incitements to honour killing. In any event, this particular incitement did not lead directly to an honour killing. However, incitements can have an escalating effect in that they might persuade the person concerned that his community will support him if it comes to a killing.²⁶

We should not assume that every instance of loss of *namus* involves an incitement to kill. Dissuasion occurs as well. In the case of Abdullah (see 6.1), whose daughter ran off with her boyfriend just before the wedding, family and friends did all they could to talk Abdullah out of an honour killing. Six months after his daughter's elopement, he was still muttering that he would do it, but he seemed to content himself with disowning his daughter. In the Uzun case study too, the father was warned against an honour killing. His younger brother, who lived in Turkey, wrote to him, advising him to seek a peaceful alternative: "In Turkey, the penalty for abducting a married woman is seven or more years in prison. You have to take the matter to court [...]. Put those crazy ideas out of your head. You still have other children and a wife. Follow the rule of law" (see 6.5). In the Ayanoğlu case study, it was a sister who warned her brother against committing an honour killing.

Job loss and fear of unemployment

There may be a greater likelihood of an honour killing if the isolation that accompanies loss of *namus* carries with it financial implications as well. It is bad enough for a man to be shunned by his community because he has no *namus*, but for those who own their own business

and depend on the Turkish community for their livelihood, it can be disastrous. Customers stop coming and the *şeref* these men derive from being successful businessmen suffers.²⁷ De Vries cites an example of the Turk, H., who watched his business go bankrupt because the Turkish community felt that his daughters were behaving immodestly: ‘Mr. H. ran a business selling Turkish goods and was therefore dependent on Turkish customers [...]. The local Turks did not appreciate the [...] rather free behaviour of the girls [his daughters]. Thanks to a neighbourhood gossip campaign, people stopped buying from Mr. H. and he was forced to sell his shop.’²⁸ Something similar may have happened in the Dursun case study. Mehmet, Zeynep’s brother-in-law, attempted to turn his coffeehouse into a Dutch café with a Dutch clientele, claiming that Turks were ‘whingers’ and that he preferred Dutch customers. Perhaps, as the Turkish community came to learn of Zeynep’s affair, they had begun avoiding Mehmet’s coffeehouse. If Zeynep’s moral conduct was the reason for the exodus of Turkish customers, we can imagine that Mehmet would have wanted to limit the loss of *şeref* by saving the family *namus*. Ginat came across a similar example: a rabbi did not resort to an honour killing until his job hung in the balance.²⁹ However, matters need not come to an honour killing, as we saw in the case of Mr. H. above.

The modern husband and father

The prevailing view in Turkish rural culture is that a man should not grant his wife and daughters too much freedom as this may endanger his *namus*. This is illustrated in the saying, ‘*Kızını dövmeven dizini döver*’ (A man who does not beat his daughter slaps his thigh) [a gesture expressing regret]. In other words, men who are not strict with their daughters will live to regret it. There is a similar saying about married women: ‘*Sirtında sopa, karnında sığa*’ (A rod to her back, a child in her belly).³⁰

In three case studies, fathers or husbands had allowed their daughters or wives considerable freedom. In the Tekin case study, Mustafa said that, unlike so many other Turkish fathers, their father had never coerced them. In the ‘Death on the phone’ case study, Utlu said that his own forced marriage had given him such an aversion to Turkish conventions that he allowed his wife considerable latitude. In the Çetin case study, Çetin – the brother and honour killer – said

that he had always had to listen to gossip about his sister because their father had not restricted his daughter's freedom and had allowed her to study. Çetin told the police how he had reacted when he heard about the rape of his sister: "How terrible for my father. He always gave her freedom. He trusted her and was proud of her. He always said 'my daughter will not behave dishonourably.'"

In all three cases, however, people started to talk about the wife or daughter. Perhaps it was even worse for these fathers, husbands or brothers than for others because it meant admitting to the Turkish community that their approach had failed. If they had conformed to traditional patterns of behaviour, their loss of *şeref* may not have been so great.

7.2. Objectives other than honour purification

Some honour-killing cases involved objectives other than purification of *namus* alone. Motives ranged from incitements to kill certain people, restoring the honour killer's *şeref*, improving a girl's chances on the marriage market and taking the children away from the stepfather, to crimes of passion.

Incitement to kill certain people

Several instances of what Ginat defines as 'public accusation', I would describe as incitement to kill certain people. Ginat's case studies III and IV both involve uncles urging a nephew to commit an honour killing.³¹ The uncles had their own reasons for inciting the killing.³² According to Ginat, the loss of honour was simply a pretext.³³ In my research, the Uzun and Altuğ case studies are illustrations of this. In the Uzun case, two men from the Turkish community urged the Uzun family to commit the honour killing and they helped purchase the firearm. In the Altuğ case study, one, Akbulut, had a vested interest in the honour killing, probably because he was involved in blood revenge with the male transgressor. Akbulut helped with the preparations and gave the honour killer shooting lessons.

People who stand to gain from an honour killing may seek to convince the aggrieved man that his honour is at stake. In Shakespeare's *Othello*, Iago sought to persuade his master, Othello, that lieutenant

Cassio was seducing Desdemona, his wife. Iago wanted to take Cassio's place and was delighted when Othello finally killed Cassio. Ginat cites a folktale in which, although no honour killing took place, a man was persuaded that he had forfeited his *namus*. He was told that his wife was committing adultery. Because he loved her so much, he did not kill her, but banished her instead. Years later, when he discovered that he had been tricked by his jealous sister, he traced his wife's whereabouts and they lived together once again.³³

Social ambitions

According to Kressel, social ambition is one of the considerations governing a decision to commit an honour killing. In my view, this only applies to societies that place great importance on a return to traditional values. This appears to be the case among the Arabic Muslim community in Israel, where Kressel observes 'the socio-political climate of a return to Islam that is one of the marks of recent years [...]'. He notes that: 'An improved economic position stimulates the desire to translate this into the coinage of traditional social prestige.'³⁴ In most societies, and Turkish society is no exception, an honour killing will not improve the killer's social mobility.³⁵ However, as happened in the Türkmen case study, a man may attempt to regain his lost status by means of an honour killing within his own class, where such killings are viewed positively. Türkmen, an alcoholic and the black sheep of the family, may have seen the honour killing as a way of regaining his family's respect.

Making the girl marriageable again

In some honour killing incidents, the killings were clearly carried out to restore the girl's marriage prospects. In the Altuğ case study, it was rumoured that the daughter was having a sexual relationship with Hacı Kalkan. Mesut Altuğ, her nineteen-year-old brother, killed Hacı Kalkan. The petition for clemency for Mesut was worded as follows: "Hacı Kalkan has destroyed the life of Mesut Altuğ's sister. Her marriage prospects are practically nil. She can scarcely show her face in her village. Normally, only prostitution would be open to her. Why does the public prosecutor demand a 12-year prison sentence for this worthy and honourable act? It would rob the unfortunate sister of her

protector.” In other words, thanks to Mesut Altuğ’s honour killing of the male transgressor, the girl’s *namus* has been cleansed and her marriage prospects have been restored.

In the Yiğit case study, Ayşe, the daughter, was no longer marriageable. Mrs. Yiğit spoke of their holiday in their native village three years after the incident in the shed: “That holiday was terrible [...]. People were saying that we went about in the Netherlands in short dresses and no headscarf. My husband became increasingly tense because nobody came to ask for our daughter’s hand. But he didn’t discuss it with me. I know that it was very difficult for him because, as the girl’s father, he could do nothing about the situation.” Here the mother meant that, as parents of a daughter, they had no choice but to wait until a marriage proposal was forthcoming.

My own feeling is that a girl at the centre of a scandal is not unmarriageable, but rather has forfeited the prospect of a good marriage to someone from her home village. I believe that parents can always find a marriage partner for their daughter, even if he is just a poor widower, an old man, or a man who lives a great distance away. However, such a marriage would seriously damage the father’s *şeref*. In my view, the father of Songül in the ‘Denmark’ case study did not commit the honour killing to restore Songül’s marriageable status, but to ensure that she made a good match. Yiğit could have married his daughter to an outsider, but he naturally preferred someone from his own village. And after the honour killing, he did succeed in arranging such a marriage. The court records include a petition for deferment of sentence, in which Yiğit requested permission to stay at home to look after his sons, as his wife and Ayşe were going to their native village for Ayşe’s marriage to a fellow villager.

Taking the children away from the stepfather

Some honour killings demonstrate how important it is for a man to have control over his children, as they are his descendants. The view prevails in Turkish rural culture that children belong to the family of the husband. The man continues the family line by way of his seed; the woman is simply the ‘field’ in which the seed is able to grow.³⁶ A man may divorce his wife and allow her to bring up the children. Problems do not arise unless she subsequently acquires a boyfriend, as men generally do not want their children to be raised by another man.³⁷ In the Ayanoğlu case study, the husband was prepared to

leave the children with his estranged wife, provided she ended her relationship with her boyfriend. She refused to do so. In the Türkmen case study, the honour-killing decision was probably taken, not because Emine reabducted the children, but because she then raised them together with her new boyfriend and would almost certainly be granted custody. The Dağ case study clearly demonstrates a man's refusal to accept another father for his children. The children were allocated after the divorce to Idil Kalkan, the mother. When she began a new relationship, her ex-husband, Efe Kalkan, who was serving a prison sentence in Spain for drug trafficking at the time, arranged for her to be killed. He was then granted custody of the children and had them taken to his parents in Turkey. Wanting the children back does not mean that a man is prepared to care for them himself; he simply wants them back in the family.

Crime of passion

In the Köksal and Çetin case studies, *namus* was violated when the wives had extra-marital affairs. For the women themselves, the honour killing was probably also a *crime passionnel* in that they killed or arranged for the killing of the lover who had abandoned them. The women's *şeref* was at issue: they were offended by a lover who no longer cared for them.³⁸

Men too may commit crimes of passion. A young man who has his eye on a particular girl may be unable to tolerate the fact that she is seeing someone else. He kills her because he believes his *namus* to be injured, although there can be no such injury since the girl is neither married nor promised to him.³⁹ I would call this 'murder/man-slaughter for reasons of male pride' rather than an honour killing.

The *crime passionnel* element may constitute a further motive for the honour killer. One of the reasons that Mehmet Tamer, a minor, killed his cousin Sevda in the 'Stabbing in the square' case study was that he might have seen her as his future wife. Mehmet told the police: 'I loved her. I couldn't bear the fact that the girl I loved ran away from home to go to someone else. So I killed her.'⁴⁰ Yet this sheds a different light on the lawyer's claim that the boy was compelled to do the deed. Instead, it seems that the murder was an act of retaliation against a girl who refused to sit quietly at home and wait until she was married off to him.

7.3. Provocation

Several honour-killing cases demonstrate that provocation by the male transgressor reduces the prospect of a peaceful solution. Provocation includes defiant behaviour, making a girl pregnant without intending to marry her, sexual insults and spreading gossip and slander.

Defiance

Without doubt, some men openly imperil or injure the *namus* of another through their defiant behaviour. Çağman's behaviour to the Şengül family exceeded all bounds: what man in his right mind comes to the door demanding the woman of the house for himself? In the Altuğ case study, Hacı Kalkan broadcasted the fact that he had had a sexual relationship with Altuğ's daughter, and he wrote a letter to Altuğ outlining his feat in intimate detail. It is hard to imagine a greater humiliation: not only did Altuğ forfeit his *namus*, he was also humiliated by Kalkan's eagerness to publicise the deed, which dealt a severe blow to Altuğ's *şeref*. The court records do not reveal why Hacı Kalkan behaved in this way. He probably bore a grudge against Altuğ and thought himself invulnerable. In the Elmas case study, the Dutch boyfriend told Elmas rather bluntly that he did not need his permission to marry his daughter. Being Dutch, he was presumably unaware that permission from the father was a prerequisite for the marriage. I believe, however, that this unintentional provocation at most added fuel to the flames; Elmas had probably already decided on the honour killing.

In the 'Summer camp' case study, Çetin demanded an explanation from Özbay, his wife's lover. Instead of offering his humble apologies, Özbay said: "What business is it of yours?" which Çetin took as a provocation. According to Çetin, this conversation alone prompted the decision to proceed with the killing. It seems more likely, however, that this 'final talk' was part of the planned honour killing; at most, Özbay's response may have helped spur Çetin into deciding to kill him.

Pregnancy

Three questions of honour involved a pregnancy. In the Köksal case study, when the girl became pregnant by Hikmet, vain attempts were made to arrange a marriage between them. Hikmet then fell victim to an honour killing. In the Altuğ case study, the daughter became pregnant by Hacı Kalkan, a married man, who refused to take her as his second wife. The pregnancy ended in a miscarriage and Hacı Kalkan was killed. In the Uzun case study, Meral became pregnant by her lover, Makal, who had two wives already. He took her to Turkey and abandoned her there. Meral had written to him in desperation: 'Makal, I am carrying your child. How could you leave me like this?' Meral miscarried and Makal was killed.

The fact that the three male transgressors allowed matters to proceed as far as a pregnancy may have made an honour killing more likely. The pregnancies could be interpreted as a provocation: saddling a man with a bastard child whom he must care for is a low trick for one man to play on another. By taking no responsibility for the children themselves, the male transgressors demonstrated their superiority. They humiliated the other, thus striking a severe blow to his *şeref*. This aspect is expressed clearly in Mesut Altuğ's letter to the court in the Altuğ case study. He wrote: 'They had planned for a bastard child to be born in our house. If our girl gives birth in our house, we are without *namus*, without faith and without *şeref*.'⁴¹

Extra-marital pregnancies are highly problematic, hence the decision in the Köksal case study to arrange for an abortion. In the Altuğ and Uzun case studies, it is probably no coincidence that the 'miscarriages' occurred in Turkey. These may have been induced abortions or honour killings of the newborn babies.

Sexual insults

Sexual insults are another form of provocation. They can give rise to a question of honour, which is sometimes followed immediately by an honour killing (see the Ercan case study). Gilsenan writes: 'For a face-to-face insult or blow, instant retaliation may be demanded, at least when an audience whose judgement is significant for the one challenged is present.'⁴² If a question of honour already exists, the utterance of a sexual insult may escalate matters. One example is the

Koparan case study, in which the threats of Gürdal and his son gave way to sexual insults.

Gossip and slander, harassment and threats

If a marriage proposal is rejected, or a father fetches back a daughter who has eloped, the boy and his father may feel so offended – because of injury to their *şeref* – that they spread gossip about the family responsible. Gossip that is without foundation and whose sole purpose is to injure a woman's reputation is called slander (*iftira*) rather than gossip (*dedikodu*). We see an illustration of slander in the Yiğit case study. Gürdal was so insulted by Yiğit's actions (suggesting that his son had violated the *namus* of Yiğit's daughter and thus urging a marriage between them) that he and his family began spreading slander about Yiğit's wife and daughter. Without doubt, this caused the question of honour to escalate. The incident in the shed was not forgotten; instead, Yiğit's daughter acquired a dubious reputation.

7.4. Circumstances of the honour killer or accomplice

We can point to specific circumstances relating to the honour killer or accomplice that may have increased the likelihood of an honour killing. These are unemployment, a close relationship to the male transgressor, and the honour killer's personality.

Unemployment

It is conspicuous how many honour killers or accomplices were unemployed: in other words, they had little *şeref*. Of the nineteen cases for which we have information on this point,⁴³ ten involved an unemployed honour killer or accomplice,⁴⁴ and one an honour killer with a poorly paid job (the Ercan case study). Men who have nothing else from which to derive their *şeref* cannot tolerate a wife's dishonourable conduct. Their *şeref* is primarily determined by their *namus*: in other words, by their ability to protect their wife and daughters, and the fact that their wife and daughters show them respect. If they lose their job, their world shrinks; if they lose their *namus* on top of that, their world is reduced to nothing. Van Stolk's research among Dutch

men reveals that those who are unemployed or who work in low-paid, low-status jobs find it hard to cope if their wife leaves them.⁴⁵ Men from lower socio-economic groups tend to display more extreme forms of masculine behaviour because their sense of self-worth has been undermined by their sense of inferiority to higher-status men. Their marriage is all the more indispensable for boosting their feeling of superiority, and they will be more inclined to resort to violence where necessary.⁴⁶

In the Köksal case study, Aslantaş was unemployed for six years and received a benefit. Unable to derive *şeref* from his job, he compensated by showing off his daughter. He put on an expensive wedding, which he could ill afford, only to discover that his daughter was not even a virgin at the time of the wedding. Worse still, she was pregnant by another man. In the Şengül and Dursun honour-killing cases, the husbands were declared medically unfit for work and hence unable to find employment. To make matters worse, their wives were having affairs with other men, which other people then found out about. In the Ayanoğlu case study, as well as being unemployed, the husband had a gambling addiction. He was dependent on his wife, who worked to pay off his gambling debts, but there she met someone else.

In the Çetin case study, Mrs Kalemli was the family breadwinner, while her husband stayed at home and looked after their six-year-old son. He was not happy about this situation, and the court records reveal that he was keen to have paid employment. The fact that he was unemployed and financially dependent on his wife gnawed away at his sense of self-worth. When his wife permitted herself an affair, Kalemli must have felt very humiliated, as well as powerless. The knowledge that he was dependent on his wife will not have made him over-eager to divorce her. But his situation may have strengthened his desire to get even with Özbay, his wife's lover.

Unemployment, however, is just one of many possible factors. Some honour killers did have jobs and were relatively wealthy. Tekin, for example, had been to Mecca, owned large tracts of land in his native village and had a job in the Netherlands.

The relationship between honour killer and honour violator

Blok points to the important role of friendship in relation to murder. The Mafia set great store by trust and loyalty.⁴⁷ Betrayal within a

friendship is more likely to lead to murder. At first sight, this appears contradictory; we might expect friends to make more of an effort to find an alternative solution. However, it is precisely because friendship is involved that betrayal cannot be borne and is punished more readily with death. This fact may be relevant to studies of honour killings, in that there may be a greater risk of a killing if the male transgressor is a close friend.⁴⁸

Eight of the honour killings in my case studies involved a close friendship: in three cases, the wife was having an affair with her husband's best friend (Şengül, Çetin, and Türkmen), in two cases, the daughter was involved in such a relationship (Uzun and Altuğ), and in the remaining three cases (Yiğit, Koparan, and Şener), the father refused to grant permission for his daughter to marry a good friend's son, thus deeply offending the friend. This latter category can be easily understood in the context of Turkish rural culture, where marriage between the children of friends confirms the friendship. A marriage is more than just a tie between husband and wife; it strengthens the bond between two families. If a friend rejects a marriage proposal, this is easily interpreted as a desire to end the friendship.

The honour killer's personality

In the Biber case study, in which Mevlüt killed his mother, he was described as extremely aggressive. One year before the honour killing, a psychologist wrote: 'We should bear in mind that Mevlüt himself might kill his mother or father. He has no other options for putting an end to the almost insoluble problems of his family.'

Some people are more prepared to kill than others. Two well-known Bedouin stories, cited by Ginat, demonstrate how differently people can react when their *namus* is violated. In one story, a man who discovers that his wife is committing adultery kills his daughter to prevent her from injuring his *namus* in the future. In the other story, cited earlier in this chapter, a man learns of his wife's adultery but, because he loves her so much, chooses to banish rather than to kill her. Ginat says of these stories: 'It is perhaps an indication of the ambiguous attitude to the issue (of honour crime) that both tales are equally popular [...]. They seem to represent two possible and widespread reactions, and show the extreme ends of a scale of possible attitudes.'⁴⁹

In the Şengül case study, the honour killing was not carried out by the eldest son but by the second to eldest, who was known to be more vigilant than his older brother Hasan. The probation officer described Hasan as ‘rather a softie’ who ‘gives the impression of being rather slow’. In the Bitlis 3 case study, the boy could not bring himself to strangle his sister. His hands began to shake and he started crying, at which point his older brother finished the job. In the Altuğ case study, the fifteen-year-old Hikmet was supposed to commit the killing, but his brother Mesut, four years his senior, took over at the end because he feared that his brother was not up to it. Although these three cases reveal the role played by personality, it appears to determine who carries out the killing, and not whether it should occur in the first place.

Further research needs to be conducted into the question of whether or not personality is decisive. The court records in the Koparan and Gürsel cases reveal that people who are perceived as quiet types are nevertheless capable of committing an honour killing. It is incorrect to ascribe honour killings to aggressive people alone. Honour killings frequently entail thorough preparation, which in turn requires the ability to control emotions. Almost without exception, the honour killers had no previous convictions.

Several honour killers who suffered from the Othello syndrome were so jealous that they imagined that their wives had a lover (see 5.5).

7.5. Honour killing following an elopement

In some cases, aspects of an elopement made an honour killing more likely: either the boy was not acceptable or the girl was about to marry.

The ‘suitor’ is not acceptable

According to Kressel, there is a greater risk of honour killing if the marriage match deviates from the social norm; for example, if a rich girl marries a poor boy. In such a case, the purpose of the honour killing is not simply to purify *namus*, but to circumvent the undesirable marriage.⁵⁰ If this were correct, however, we could expect many more honour killings following elopements as almost all elopements

involve poor boys and girls from wealthier families.⁵¹ Kressel makes this same point.⁵²

In the Tekin, Gürsel and Uzun case studies, the girls' lovers were married men with children. Although the girls' families were unhappy about this, there is no proof that this prompted the honour killing. Uzun was quite prepared for his daughter to marry a man with two wives, and the Gürsel family agreed to a marriage provided the man divorce his first wife. In the Tekin case study, the father was totally opposed to such a marriage, but not for this reason alone.

Sunnites and Alawites are not keen for their daughters to marry into the other group. In the Ardal case study, Ardal's daughter eloped with an Alawite who was a friend of her brother's. It appears that this friendship had never given rise to problems: it was not until the Alawite wished to marry a daughter of the family that religious differences became insurmountable. In the Elmas case study, the daughter wanted to marry Jan, a Dutchman. Elmas was known to be a very pious Muslim, and he refused to accept the idea of his daughter's marriage to a non-Muslim. However, we do not know whether this played a role in the honour killing. Elmas himself had suggested a solution: he asked Jan to convert to Islam (though this request may have been insincere) and Jan had agreed to do so.

The girl is about to marry

In the Sliedrecht case reported in Van der Molen, the girl had a fiancé in Turkey, thus making the scandal surrounding her friendship with a Dutch boy all the more serious.⁵³ An elopement is a fairly common strategy for escaping an arranged marriage. The fiancé will usually lose all interest in the girl who has eloped and will call off the wedding. In the Tekin, Elmas and Uzun case studies, however, the disgrace to the girls' parents and prospective in-laws was compounded by the fact that the girl was not only promised to the boy but was at the point of marriage. In the Tekin case study, the family was all set to travel to Turkey that same month for the wedding celebrations. In the Elmas case study, the father himself had made sure that the wedding would take place as soon as possible. In the Uzun case study, the bridegroom (*damat*) had already arrived from Turkey and was staying with relatives in Germany until the wedding.

In the Tekin case study, involving an arranged marriage that clearly had the daughter's support, Tekin would have found it partic-

ularly hard when his daughter ran away. By running off just before the wedding, she made it look as though he had wanted to marry her off against her will, which was far from the truth. In the Abdullah case, in which the daughter also ran away just before the wedding, it was this fact that upset her father most. The engagement to the boy in Turkey had been very much his daughter's idea. Abdullah had warned her that, at sixteen, she was still very young and might fall in love with someone else. 'Today it's Mehmet, tomorrow it will be Ahmet,' he had said to her. But she was determined. Two years later, just before the wedding, she left home to join her boyfriend. "Now it looks as though I wanted to marry her off against her will," said Abdullah. Six months later, Abdullah was still unable to accept what his daughter had done to him. He made it clear that *şeref* played an important role: his daughter had gone to live with her boyfriend. When I asked him whether he would be happy if they married, he said that it would make no difference; he had disowned her. Marriage would resolve the question of honour (*namus meselesi*) but the greatest blow for him was the fact that she had run off just before the wedding.

7.6. Honour killing within the family

In cases where daughters or wives are killed, there is probably more at issue than the fact that they were responsible for loss of *namus*. Although custom demands that the guilty party be killed, in practice, a way is usually found to let the wife or daughter off the hook. For example, by making the boyfriend or lover out to be a rapist. However, we can point to several factors that increase the likelihood of the girl or woman being killed.

The mother or sister has a bad reputation

Earlier misconduct on the part of the girl's mother increases the likelihood of an honour killing. 'Like mother, like daughter' is a widely held belief where *namus* is concerned. In other words, if the mother's reputation is in any way tainted, the girl is tarred with the same brush.⁵⁴ Moreover, a father's previous experiences in this area probably render him hypersensitive to injuries to his *namus*.

In the Elmas case study, Ayşe, who ran off to her Dutch boyfriend, was a daughter from Elmas' first marriage. His first wife had left him for another man. When Elmas remarried, Ayşe continued to live with him. Hasan, Ayşe's brother and the one who killed her, said that Ayşe had a stain on her name because of her mother. The psychologist wrote in his report: "Hasan emphasised the legitimacy of his deed once again by saying that Ayşe's mother was a 'whore' [...]. It is not unlikely that the Elmas family already harboured a negative opinion of Ayşe because of what her mother had done, and that this negative picture was reinforced by her conduct. If Ayşe's mother was seen as a whore, then the Elmas family will have viewed Ayşe with mistrust. They would have always been alert to her behaviour." According to Ayşe's father and brother, by running off with a man, she had behaved exactly as her mother before her. The incident with Ayşe served as a reminder to everyone, including her father, of what Elmas' first wife had done. The same may be true of the 'Euphrates' case study from the *Hürriyet*. Here, the girl's mother had left her family and divorced her husband. Perhaps he could not bear yet another attack on his *namus*.

In Van der Molen's 'Sliedrecht' case study, the mother of the runaway girl had gone off with another man. The girl continued to live with her father, who remarried. When the daughter moved in with her Dutch boyfriend, the gossip mills of the Turkish community started to grind, with people claiming that the girl was the daughter of the first wife's lover; in other words, the fact that she was the daughter of an adulterous woman would explain her immoral conduct. And she was not even her father's daughter, but a bastard child.⁵⁵ In this case, as in the Elmas and 'Euphrates' case studies, the girl was killed.

The stepmother

In Van der Molen's 'Sliedrecht' case study, the role played by the stepmother is suspect. Van der Molen writes of the dead girl: 'Her relationship with her stepmother was [...] not very good, which also affected [...] the honour killer, who was a son from the second marriage.'⁵⁶ In Ginat's case study II, we see the questionable role of the stepmother very clearly.⁵⁷ A man with two wives had four daughters by his first wife and two sons by his second. When one of the daughters began an affair with a farmer, the father made sure that

the farmer left the village to seek work elsewhere. However, the second wife was not content with this solution and complained to everyone that her husband had failed to act. In response to this accusation, the man ordered the girl's half-brothers to throw her into a well, which killed her.

The Elmas case study also involved a stepmother. Officially, it is not clear what role she played in the honour-killing decision. However, when Ayşe was shot in front of her house, her stepmother stayed inside and did not run to her assistance, which might suggest that she had known about the killing.

The girl is seen as bad

A daughter may be killed because her family considers her irredeemably dishonourable (*namussuz*). There is then little to be gained by killing the male transgressor; the girl might simply go on to tarnish her family's *namus*. In the Gürsel case study, the girl had a bad reputation because the divorce from her first husband had been at her instigation. She initially returned home to live with her parents but then left again to move in with her boyfriend. When wedding preparations were almost complete, she left her boyfriend. All of this may have convinced the Gürsel family that there was no hope of her ever behaving properly.

The girl attempts suicide

In both the Elmas and Gürsel case studies, the girl attempted suicide and had to be admitted to hospital for treatment. The families probably saw the suicide attempt as an admission of guilt, for it showed that their daughters preferred to kill themselves rather than be denied the right to live as they chose. The parents would have seen no solution to the problem. If they married her off properly, she would run away again or commit suicide, thus bringing scandal to her family.

The role of the hoca

In the Elmas case study, a *hoca*, or Sunni cleric, was asked for his advice.⁵⁸ It is not clear whether he was appointed by the mosque, but my impression is that his position was an unofficial one, involving the writing of amulets. The *hoca* put a curse on Elmas' daughter, saying that she would die within a month. The son then killed his sister. We cannot be sure, however, to what extent the Elmas family was guided by the *hoca*. The father may have gone to him simply to seek moral approval for a deed he already planned to commit.

In the Ardal case study, the father was a *hoca* who was well known amongst Turks in the Netherlands. He had ostensibly reconciled himself to his daughter's elopement with her Alawite boyfriend. Although the son carried out the honour killing, it was rumoured in the Turkish community that the father was behind it. The fact that he was a *hoca* perhaps supports this view. Sunnites and Alawites are known to discourage their daughters from marrying into the other group (see 7.5).⁵⁹ Perhaps Ardal, as a Sunni cleric, could not afford to lose his daughter to the Alawites, as this would mean undermining his authority within his own group. His position as a *hoca* may also be the reason why he arranged for his daughter to be killed rather than her boyfriend. *Hocas* have an exemplary function: their behaviour should be beyond reproach. For this reason, he may have been averse to the deception involved in pretending that his daughter was innocent.

The sister behaves provocatively

According to Sinan Ardal, he killed his sister because she showed him no respect in a particular discussion. In my opinion, this conversation was not a later fabrication on Ardal's part; it actually took place and affected him profoundly. I do not believe, however, that the perpetrator contemplated an honour killing only after the discussion had taken place, and that he acted on this decision immediately. It appears to have been the 'final talk' that is a customary element of the honour-killing procedure. If, in the eyes of the honour killer, the victim gives improper, dishonourable answers, this provides additional justification for the killing. Because he could not reveal what preceded the killing (namely, a family council), Ardal attributed all the blame for the honour killing to his sister's insolence. It had to appear

as though he had acted entirely on his own initiative. And perhaps he thought that he would not kill her if she showed real remorse. In that sense, her “inappropriate” answers proved fatal.

In the Dursun case study, Mehmet questioned his sister-in-law, who refused to apologise for having committed adultery. However, it is improbable that this is what prompted Mehmet to proceed with the honour killing. Here too, the conversation was probably the ‘final talk’. The assassin had already been hired and was waiting outside for the victim.

The favourite

Elmas used to say that he had two flowers, his first child and his last child (both daughters), by which he meant that they were his favourites. Nevertheless, he arranged for his son to kill his eldest daughter. In the Gürsel case study, Ahmet said that Fatma was his favourite sister, yet he was the one who killed her.⁶⁰ In a 1999 documentary about honour killings in Jordan,⁶¹ a brother who killed his sister also claimed that she was his favourite.

What interpretation should we place on this? Perhaps matters are exacerbated if the one who behaves dishonourably is a favourite child or sister. This would be comparable to the situation I described earlier with regard to friendships, namely that people are prepared to tolerate much less from a good friend than from others. But this begs the question of why the daughter or sister is killed and not the male transgressor. In the Tekin case study too, the dishonourable daughter was her father’s favourite, but Tekin killed the male transgressor. He was the one who had dared to touch Tekin’s daughter, which makes the honour killing easier to understand.

Disowned or separated

In the Türkmen case study, Emine was killed by her brother Sedat, presumably with his parent’s backing. In this case, it may not have been so difficult to go that one step further and kill ‘their own flesh and blood’ because Emine had already been disowned. Her social death – when her family banished her from their lives – had occurred already. They then killed her because she failed to adhere to the

‘rules’ of banishment: she re-entered her ex-husband’s life by abducting the children.

The wife killed in the Biber case study was in fact an ex-wife, which may have made the killing easier. She was already an outsider, no longer someone from inside the family. Nevertheless, even as an ex-wife, she still represented a threat to her husband’s *namus*.

Blood relatives

Zeynep, in the Dursun case study, was a blood relative. Kemal and Zeynep were not only man and wife, but also *amca çocukları* (the children of brothers), which may have made Zeynep’s dishonour all the more serious. This is perhaps comparable to a favourite sister becoming the subject of gossip or a good friend attacking one’s *namus*. The phone-tap transcripts reveal that Kemal’s father found his daughter-in-law’s conduct especially hard to deal with because she was his brother’s daughter. Gökhan, Kemal’s brother, responded as follows to what the police told him about the phone tap: “At the same time, you say that my father told Kemal that he said the following to Temel [Zeynep’s brother]: ‘My daughter-in-law is his sister. If my daughter-in-law was the daughter of a third party, that I would then disown her and may God curse her [...]. But whether I disowned her or not, she would still be of my blood [...].’”

In other words, Yılmaz Dursun pointed out that Zeynep was a blood relative – a *yeğen* (his brother’s child) – and that disownment was therefore not a solution. He could not banish Zeynep from his life because she would return to her parent’s house after the disownment. He would have had to sever ties with his brother as well. In Deug, we find a clue that disownment (in this case, divorce) is not a viable solution in cases where the wife is her husband’s blood relative: “Emine tries to discuss divorce with her father-in-law (who is also her uncle) because her husband beats her. ‘I ask him: What should I do? Get a divorce?’ Then he says: ‘No no, you can’t. If you divorce him, you’ll have to be killed.’”⁶²

7.7. Other contributing factors

There are other factors that, although they do not constitute motives for an honour killing, make it easier for the killer to take that step.⁶³

Firearms

Firearms are of age-old importance for Turks. Tezcan says: 'Even if a man cannot clothe or feed himself properly, he must have a gun. He would even sell an animal to get hold of a gun.'⁶⁴ The saying, '*At, avrat, silah*' (horse, woman, weapon), which refers to the three things that – traditionally – Turkish men value most highly, demonstrates the importance of firearms. To bear arms is a sign of manliness, as reflected in the saying '*Ağalık vermekle, yiğitlik vurmakla*' (Giving makes you a gentleman, but killing makes you a man).⁶⁵ Magnarella points out that the ownership of guns is quite customary in rural areas.⁶⁶ Even many urban dwellers possess one. The many newspaper reports about children killed while playing with loaded firearms they have taken from the wall or from cupboards make sad reading.⁶⁷

Boys learn at an early age how to use guns. Tezcan says: 'In the villages in the Black Sea region, and in southeastern and eastern Anatolia, boys are taught how to use firearms at a young age. The children play shooting games in which the loser must relinquish his gun. This makes him very unhappy because his weapon is his *namus*. If his weapon is taken from him, his *namus* is gone too. Because they wish to avoid this, boys set great store by shooting practice.'⁶⁸ This is an old source but, nowadays too, boys in rural areas have access to guns. Guns are often fired into the air to add to the festivities at weddings, circumcisions, football victories, or upon returning from a pilgrimage to Mecca.⁶⁹ The same happens at summer festivals in the mountain meadows (*yayla*), such as the *Zafer Bayramı* (Victory Day) on 30 August. Stray bullets occasionally claim a victim, usually because those doing the shooting have been drinking.⁷⁰ However, the possession of an unlicensed firearm (*ruhsatsız*) is illegal in Turkey.⁷¹

Özgür and Sunar comment that possession of firearms not only provides an opportunity for violence, but provokes it as well.⁷² The fact that a gun is on hand during a fit of anger or frustration increases the likelihood of a fatal outcome. The question is whether this applies to honour killings, which are usually planned well in advance and are not the result of a sudden outburst. It may well apply to unplanned honour killings. In several honour-killing cases, the police suspected that it suited the killers' purpose to claim, alluding to Turkish culture, that they always carried a weapon with them or kept one at home (Altuğ, Ayanoğlu, Elmas, Şengül, and Yiğit). In that

way, the possession of a firearm could not of itself constitute proof of the planned nature of the honour killing.

Alcohol and drugs

Alcohol consumption may also pave the way for the decision to kill, a consideration which some perpetrators take advantage of. Ayanoğlu claimed that he had been drinking heavily on the eve of the killing. But there was no trace of alcohol in his blood. In the Türkmen case study, the honour killer maintained that he had drunk large quantities of alcohol because the obligation to carry out the killing lay so heavily on his shoulders.

The perpetrators in the Çetin and Barut case studies occasionally took drugs, and did so immediately before the killings. “To stay calm for the honour killing,” they said. The decision to kill had already been taken.

Alcohol and drugs probably played a greater role in honour killings without a lengthy preparation period. Examples include the Utlu case study, in which Utlu killed his wife’s girlfriend as she talked on the phone, and the Ercan case study, in which, following the sexual insult, Ercan went home to fetch two knives. In both cases, the killer had been drinking spirits.

7.8. The situation of immigrants

All the Turkish honour killers in the case studies gleaned from the court records were abroad, in the sense that they were residing in the Netherlands. This factor may have played a role in their decisions to commit honour killings. The first six of the points listed below expand on matters that I have already discussed.

The modern husband and father

Immigrants keep a close eye on one another, and constantly ask themselves: ‘Is he getting richer than I am? Does he have a second job? Does his takeaway business make good money?’ If the answer is yes, they feel obliged to follow suit. This can be very positive, in that it encourages people to succeed,⁷³ but it has its negative side too. The

progress of children from a father with a 'modern' outlook is observed very closely indeed. If something goes wrong, these 'eyes in their back' may place additional pressure on the fathers to cleanse their *namus*. Modern fatherhood may pose other problems too. In the Koparan case study, Koparan did not want his daughter to marry until she had completed her studies. However, Gürdal, Koparan's friend who made a marriage proposal on behalf of his son, interpreted the refusal as an insult, because it suggested that his son was not good enough to be Koparan's son-in-law.

Unemployment

It is commonly accepted that long-term unemployment forces people to turn towards their own group or country of origin.⁷⁴ If, in a foreign country, immigrants fail to improve their socio-economic position, their own values and norms acquire greater significance. We see this in the Ardal case study, in which Sinan, the unemployed honour killer, developed a growing aversion to Dutch society. Unemployment also has implications for a person's status back home. They are no longer in a position to return every year for a holiday, and if they do go, they have little money to spend. Bovenkerk and Yeşilgöz cite a young Turkish man: 'In the seventies, going to Turkey on holiday was like paradise for us, especially for my father. There, he was a king. But then he lost his job and things got difficult. We were forced to accept an enormous loss of face, not just in Turkey but in the Netherlands as well. My father went once every three years to Turkey instead of once every year, and whereas in the past he used to help out relatives, he couldn't anymore. It meant an enormous loss of power. Our status was undermined. It didn't happen just to him but to many of that generation.'⁷⁵

This loss of status is a loss of *şeref*. We can expect a man who has forfeited *şeref* in this way to take pains to ensure that his *namus* remains intact. But if he fails in this respect too, there is a greater chance that he will wish to restore it as quickly as possible, perhaps resorting to extreme measures.

The relationship between honour killer and honour violator

Living in a foreign country, apart from their wives and children for many years – Turks call it ‘exile’ (*gurbet*) – the first generation of Turkish men formed their friendships within their own group. Abroad, friends depend on one another, and their expectations of one another are high. Under these circumstances, it can be particularly painful if one friend impugns the *namus* of another.

Illegal residents

Dutch residence permits are very desirable. There are only two ways of acquiring them: by applying for political asylum or by marrying a young woman who lives in the Netherlands. Hence, the number of marriages between the children of fellow villagers, where one prospective partner lives in Turkey and the other in the Netherlands. Under certain circumstances, the one residing in the Netherlands can have the marriage partner brought over.

Young men in Turkey who cannot make such a marriage may try their luck by coming to the Netherlands as a tourist.⁷⁶ They then stay on illegally, hoping to marry a girl who lives here. One option is to enter into a marriage of convenience. The couple must then stay together for at least three years before the young man is eligible for a residence permit.

However, it is cheaper to marry a Turkish girl living in the Netherlands. If they are not related, young men living here illegally are often regarded as undesirable sons-in-law. Parents suspect them of being more interested in the residence permit than in their daughter. There is little *şeref* to be gained from marrying a daughter off to such a man.

In the Tekin case study, the scandal was exacerbated for the father when he learned that the man who eloped with his daughter was an illegal immigrant to the Netherlands. The fact that the boyfriend was thirteen years older than Tekin’s daughter, that he had a wife and three children in Turkey, and that he had already entered into a marriage of convenience in the Netherlands in order to acquire a residence permit, hardly lent credibility to his claim that he truly cared for the girl. In the Gürsel case study, the family eventually agreed to their daughter’s marriage to her boyfriend (an illegal immigrant with whom she had eloped), but by then she had already left him.

The fiancé is a member of the family

Turkish girls who elope often have a fiancé in Turkey. As a result of the elopement, the marriage does not go ahead, which is humiliating for the boy's family. It appears that their prospective daughter-in-law does not want them as in-laws (in the case of an elopement), or even worse, that another family has deliberately snatched the girl from under their noses (in the case of abduction). But the fact that the girl lives in the Netherlands makes matters worse. The elopement not only causes the marriage to fall through, it blocks the boy's departure to the Netherlands. He will not be granted a visa, let alone a residence permit.

For boys who see no career prospects in Turkey and who have pinned all their hopes on living in the Netherlands, it is a bitter pill to swallow, as it is for their families. They blame the family in the Netherlands for not looking after their daughter properly. Sometimes they go so far as to blacken the name of the girl's family and to make life impossible for them in their native village. The girl's family may be forced to take action to demonstrate that they do not condone the elopement.

In the Uzun case study, the Baş family was angry that the honour of their future daughter-in-law (*gelin*) had been sullied and that their son Mehmet had travelled to Germany for nothing. Baş wrote an angry letter to Uzun: 'Dear friend. I have received your letter. How can you infuriate someone like this? Is what you wrote true or are you just postponing things? If you didn't want the marriage to go ahead, why did you let us incur so many expenses? You've delighted my enemies. Why did you bring my son to this point? I'll seek my fortune elsewhere. I did not expect this of you.' Habib, Uzun's son, killed Makal, the male transgressor, and told the police: 'If we'd done nothing, we would have made Mehmet Baş and his family our enemies because they would have thought that we simply helped that man [Makal] to my sister. Makal has not only injured our honour, he has also made sure that the village we come from is angry with our family because we didn't look after my sister properly. Fifty to seventy percent of the people in our home village are members of the Baş family. By acting as we did, we purified our honour and ensured that this family is no longer hostile to us.'

Mistakes associated with the elopement

An elopement can escalate if mistakes are made. Sometimes these mistakes relate to cultural differences. The Turks who live together in close proximity in the Netherlands come from different regions of Turkey. Whereas elopements are very common in some parts of Turkey, in others, they represent a serious attack on honour. In the Koparan case study, Fevzi Gürdal suggested to Esengül that they should elope. Esengül refused, saying that she could not do that to her father. Perhaps Fevzi, who came from Izmir Province in western Turkey, did not understand that an elopement was a highly sensitive matter for Esengül, who came from central Anatolia. Fevzi was deeply offended by Esengül's refusal to elope with him and he began harassing her, thus attacking the *namus* of the Koparan family.⁷⁷

Cultural differences played a role in the Elmas case study as well. Ayşe Elmas became acquainted with a Dutch boy, whose parents felt that the young couple were not yet ready for marriage. They suggested instead that they live together first to get to know one another better. For the Elmas family, however, it was vital for an official marriage to take place immediately.

Men living here illegally may also make mistakes when eloping because they do not have enough relatives in the Netherlands to help them. In the Tekin case study, Halil, the young man, returned home too early with his girlfriend, despite the fact that the girl's father knew the address. He was probably forced to do so because there were no relatives who were willing and able to accommodate the couple.

Tekin himself mentioned a mistake to the police regarding the elopement. He claimed that Halil, and Halil's uncle, Abdul Gök, had applied pressure during the negotiations: "They said my daughter was no longer a virgin and that she therefore had to marry." Normally this would never have been said in so many words. In such a situation, the girl is obviously no longer a virgin; there is no need to humiliate the father unnecessarily by stating it so explicitly. It therefore seems highly improbable that Tekin was speaking the truth. The police officer involved in the case said that Abdul Gök, the mediator, held Tekin in high regard and had been unwilling to act as mediator because he did not agree with Halil's actions. It is difficult to imagine that Abdul Gök would have expressed himself so bluntly. However, it is understandable that Tekin would have presented the story in this

light to the police. He wished to emphasise that his daughter was being forced into marriage, thus necessitating the honour killing.

The police do nothing

The chapter on alternatives to honour killings revealed that, in the Netherlands, 'calling in the police' did not always achieve the results the father intended. When Tekin went to the police, he assumed that they would simply return his under-aged, run-away daughter to him. The police, however, were of the view that she had eloped of her own free will and they began marriage negotiations. The same may happen in Turkey. If the girl is of age, and there is no reason to suppose that she has been abducted, the Turkish police do not intervene either.

Light penalty for violations of the honour code

It is generally assumed that Turks who live outside Turkey are more likely to commit honour killings because they believe that the prevailing penalties for violating *namus* are not severe enough.⁷⁸ Some *namus* violations are either not punishable at all under Dutch law, or Turks believe that they are punished too lightly and feel obliged to take the law into their own hands. If the court imposes a light penalty, they do not feel that the offence has been sufficiently redressed: 'Sentencing the perpetrator may go some way toward meeting the need to see justice done, but a relatively light sentence in combination with TBS [detention in a forensic psychiatric hospital], as happens in the Netherlands in rape cases, is not always seen as sufficient punishment. Male relatives may still feel pressured by the community or by their own sense of honour to take action themselves.'⁷⁹

My case studies contain no examples of male transgressors being given too light a sentence, although there are two instances (Türkmen and Biber) in which husbands felt that their ex-wives were granted too many rights. Although women are more likely to be awarded custody of their children, the concerned husbands could not understand this, as it was their wives who had left the family. The husbands did not wait for the final court case. In all probability, they were the ones who gave the order for their ex-wives to be killed.

Incomplete family networks

If their relatives are scattered over two countries (the Netherlands and Turkey), those with an impetuous temperament may resort to an honour killing without first consulting older members of their family. A man whose *namus* is injured is completely shaken. Relatives who are less affected but have the man's trust, may suggest peaceful solutions that he himself cannot think of at the time. This may have applied in the Dursun case study. Dursun, who lived in Turkey, accused his sons over the telephone of acting too hastily. He said they should have discussed matters with him first.

Çetin gave the lack of a family network as his reason for committing the honour killing. He said that he saw no alternative when he learned that his sister had been raped because he had no one with whom to discuss it. The psychiatrist concluded: 'What was lacking here was the counsel of an older person from the same cultural background who had the authority to make the young man change his mind, for example an *imam* or someone of great authority whom he could take into his confidence. A Turkish social worker might also have helped.' An older relative could have alerted Çetin to the possibility that adultery, not rape, may have been involved. I believe that the question of incomplete family networks is a vital one. However, the court records do not divulge any further information on this point.

The desire to return

The desire to return to their village or district of origin is very strong amongst first generation immigrants. Their eventual return is their motivation for living abroad. Often, the idea of a permanent return is transmuted into a wish to commute between Turkey and the Netherlands. By spending six months in each country, they do not miss out on their children and grandchildren who stay in the Netherlands, and they are reassured by the knowledge that they have continuing access to Dutch health care in their old age. However, if a question of honour arises, the news will spread quickly back home, given that Turks live together in the same neighbourhoods in the Netherlands and maintain close links with friends and family back in Turkey. This makes a return impossible: without *namus*, they will be snubbed, which in turn means that they cannot go back.

We should not underestimate this point. These people have worked long years in the Netherlands to be able to return with what they have built up here: a house, a car, and a pension. But all of that has no value without *namus*, and the consequences are immediately apparent. They cannot go on holiday to their native village, or to the nearest town, where many villagers buy apartments. As villagers tend to congregate there in summer, the family's story would soon become common knowledge.

This frustration may provoke people to extreme forms of behaviour in order to purify their *namus*. In the Altuğ case study, Mesut killed the man who violated his sister's honour. The psychologist wrote in his report: "[Mesut] says 'our family is clean now' and points out that he can now return comfortably to his village (?)." The question mark is the psychologist's, who evidently does not see the link here. In the Barut case study too (appendix), once others found out that his daughter's honour had been violated, the father told his sons: "If we don't do something, we won't be able to go back to our village."

Increased risk of loss of namus

There is a greater chance of questions of honour arising in cities – both in the Netherlands and in Turkey – than in Turkish villages. However, this does not mean that they will end in honour killings. Nevertheless I believe that, for the Turks who are the subject of this study, as loss of *namus* becomes more likely, so too does honour killing. There are three ways in which urban migration increases the likelihood of loss of *namus*.

Firstly, when families migrate, the husband is almost always the first to move to the city or to another country, leaving his wife and children behind for several years. In two case studies (Şengül and Türkmen), this paved the way for a question of honour to arise: the wives, one of whom lived in a provincial capital and the other in a district capital, acquired boyfriends.

Secondly, everyone knows everyone else in a village; it is not possible to get lost in the crowd. For this reason, an illicit relationship is nearly impossible in a village. In a city, however, it is much easier to escape from prying eyes. If, nevertheless, others do find out, the consequences are disastrous. The ties that link ex-villagers living in the city are very strong, as is the gossip. In the summer of 1997, while staying in the village of Yaycıabdal köyü, I was told the following say-

ing by Lütüfiye, a fifty-year-old woman who lived in Ankara but spent each summer in her native village where she had lived until the age of twenty-one: "All questions of honour regarding our fellow villagers occur in Ankara." Like her, many other villagers had moved to Ankara, where they lived together in the Küçükesat neighbourhood and worked chiefly as concierges (*kapıcı*) in apartment buildings. The prevailing attitude was: 'The village is clean; the city is dirty.' (*Köy temiz, şehir pis.*)⁸⁰ The Dursun case study illustrates the increased risk of loss of *namus* in cities. Zeynep arranged to meet her lover in a car, which would have been impossible in a village. Characteristic of the Netherlands is the fact that women who wish to leave their husbands are independent and have rights. In Turkey, separated women who cannot provide for themselves return to live with their parents or other relatives, whereas in the Netherlands they are given a benefit and accommodation by the city council. Some rural Turkish men find this difficult to stomach: they still regard their ex-wife as part of their *namus* and worry that their wives will now have the opportunity to begin a relationship with another man. Strikingly, in four case studies (Altuğ, Ayanoğlu, Köksal and Uzun), the illicit love affair arose when the woman or girl went out to work. But to what extent is this an urban characteristic? In Turkish villages too, women work outside the home in the fields; perhaps secret love affairs occur there as well.

A third way in which urban migration places an increasing strain on *namus* is the resulting westernisation of migrant girls. 'Turkish girls come into contact with Dutch culture and, in the eyes of their compatriots, it is not long before they behave dishonourably,' writes De Vries.⁸¹ It is not only unmarried girls who are subject to Western influences. The same is true of young women who came to the Netherlands to be married. In the Dursun case study, Zeynep felt that she was fully entitled to her affair with Ali Eralp because her husband, Kemal, had been seeing his Dutch girlfriend on weekends for years. Ginat cites a similar example. A woman who was having an extra-marital affair refused to end it when asked to do so by her husband and father, claiming: 'Israel is a modern country and I'm not interested in outdated traditions.'⁸²

When it comes to *namus*, the fathers and brothers in the honour killing cases I describe do not seem readily affected by Western influences. They cannot accept the 'free' behaviour of their daughters and sisters. In the Ardal case study, Hüseyin, Nuran's Alawite boyfriend, told the police: "The relationship between Nuran and her parents is

very bad. Nuran has become westernised, while her parents are still completely immersed in Turkish culture; I see them as old-fashioned.” It is not only westernised girls who are unaware of the impending danger, boys are too. In her study of honour killings in Greece, Safilios-Rothschild concluded that it is precisely boys who attach no importance to traditional values who fall prey to honour killings. They enter into informal relationships with girls who share their modern outlook, unaware that they therefore risk being killed by members of the girl’s family who still adhere to traditional values and view them as honour violators.⁸³

Conclusion

When honour is violated, Turks speak of a ‘question of honour’. To escape the situation, honour must be purified. When studying court records on honour killings, one could easily jump to the conclusion that loss of honour always leads to an honour killing. After all, this is how the questions of honour set out in the court records all ended. However, most questions of honour are resolved without the spilling of blood. For instance, if a girl has a relationship with a boy before marriage, *namus* can be purified if she marries either the boy in question or another.

For the questions of honour that did lead to an honour killing, I have enquired into why people were not content with a peaceful solution, and why matters went as far as they did. Different factors may increase the likelihood of an honour killing: the failure of alternatives to such a killing, e.g. if a young man refuses to marry the girl whose honour he has violated, and if *şeref* is involved.

Şeref is also honour, but in the sense of ‘respect’, ‘status’, and ‘prestige’. Because *namus* is part of *şeref*, once *namus* is sullied, *şeref* is automatically affected to a greater or lesser extent. The less *şeref* that remains, the higher the risk of an honour killing, as happens if the question of honour becomes common knowledge, or if there is provocation, a direct confrontation with the loss of *namus*, incitements to honour killing, ulterior motives behind the honour cleansing, or if the boy with whom the girl elopes is deemed unacceptable.

In addition, I have examined a possible link to the situation in which Turkish immigrants find themselves. The fact that the question of honour arises ‘abroad’ makes escalation to an honour killing more likely. Because the Turkish migrants who came to the Netherlands in the 1960s and 1970s have had to rely so heavily on one another, the Turkish community abroad has acquired a heightened significance. Social control is such that loss of *namus* leads to social isolation. For men who derive their status from *namus* alone, the loss of *namus* is even more dramatic. These are the men who eventually – often in the 1980s – lost their jobs, became ill or were declared unfit for employment after long years of hard work. The *şeref* of these un-

employed men consisted primarily of their *namus*. In addition, escalation to an honour killing is often prompted by the greater freedom enjoyed by Turkish women and girls in the Netherlands compared with their native village, and the fact that family members are widely scattered. The fact that older family members live in Turkey means that they are not present to act as intermediaries if a question of honour arises in the Netherlands. These factors are discussed at length in chapter 7.

The incidence of honour killing will not decline until there is an end to the current level of social control. This in turn will not diminish until there is no longer a group of immigrants of whom it can be said that 'everyone knows everyone else's business'. The key to achieving this is the integration of migrant children into Dutch society. With a good education, they will be able to seek work outside the circles in which their parents have moved, thus allowing them to escape the network of close relationships in the Turkish community.

Appendix I. More case studies from the court records

THE AKKAYA CASE STUDY: 'THE YOUNG COUPLE MOVES IN WITH THE PARENTS' (1980)

After his divorce, Akkaya, a 41-year-old Kurdish man, marries Özlem, who is 21 years younger than he. Together they raise three children, aged nine, seven, and three. The two eldest are children from Akkaya's first marriage. Özlem is expecting their second child. One day Sedat Oğuz, a good friend and a workmate of Akkaya's, asks him if he can provide temporary accommodation in his home for their workmate, Faruk Taş, and his wife, Yasemin, who have nowhere to live. Akkaya finds this quite acceptable, especially as he is about to go on holiday to Turkey. But when they return to the Netherlands, it seems that two families living under one roof is more problematical than they thought.

Faruk Taş stays home sick for a few days in September, which immediately rouses Akkaya's suspicions. Faruk and Akkaya's wife, Özlem, are now at home by themselves during the day (Faruk's wife works during the day). He suspects they might be having an affair. He notices that Özlem's lips are swollen and he questions her about it. He also takes immediate precautionary measures. He has his eldest daughter, aged seven, stay home from school and tells Faruk Taş that he doesn't think it's a good idea for him to stay at home.

But after a week his daughter has to return to school because her teachers are becoming insistent. That same day, Faruk Taş reports sick again. Akkaya once again notices Özlem's swollen lips, but this time he doesn't just question her, he gives her a vaginal examination as well. He concludes that she has had sexual intercourse. He orders Faruk Taş to leave the house within a week, but he doesn't tell him the reason.

Faruk Taş enlists the help of their workmate, Sedat Oğuz, who drops by four evenings later to mediate. When Faruk Taş leaves the room for a moment, Akkaya tells Sedat Oğuz his reason for wanting Faruk gone, whereupon Sedat Oğuz decides that he should stay out of the matter. When Faruk Taş returns, a violent quarrel develops between him and Akkaya. Faruk Taş

threatens to get Akkaya if he is evicted from the house, and Akkaya says that he is not afraid of Faruk. Sedat Oğuz leaves, hoping that the matter will fizzle out.

By coincidence, Faruk Taş learns the following day that the council has found accommodation for him. After he and his wife move out, the two families exchange courtesy visits, after which they stop seeing one another. According to Akkaya, however, Faruk Taş has come in secret on one occasion to see Özlem. He cross-examines his wife, but she doesn't wish to talk about it. He then slaps her face. One month later, in November, Özlem arranges for her 7-year-old stepdaughter to move out of their bedroom into a room of her own. Akkaya interprets this as Özlem wanting their bedroom kept free during the day. He once again subjects her to an internal examination, convincing himself that she has had sexual intercourse. He is completely beside himself. At the end of January, he once again suspects Özlem of adultery.

In February, Özlem gives birth to a daughter. In March, Akkaya notices that Özlem has swollen lips, and concludes that Faruk Taş has been to his house at night-time. That month he wakes up three times during the night and hears someone running away from the front door. On the first two occasions, Özlem is not in her bed, but downstairs. When, on the second occasion, he tries to examine his wife, she flees the house and goes to the neighbours. The third time, he sees Faruk Taş running away from the front door. Akkaya feels totally wretched.

In May he is woken by a nightmare. Subjecting his wife to an internal examination, he discovers sperm in her vagina. He decides to shoot them both – first Faruk Taş and then his wife. He wants to shoot them as close together as possible,¹ but not too close as he doesn't want his wife to hear the shots that kill Faruk Taş. Akkaya makes preparations by checking out various locations in the city to see where he can best carry out the murders. He also checks the route that Faruk Taş takes to work. He decides the best location is a park close to a building site. He plans to leave his wife there early one morning, telling her that he is going to buy flowers. Meanwhile, he will go to the building site and hide there with his pistol. When Faruk Taş comes past, he will shoot him and then run to his wife and shoot her too.

Because his wife might become suspicious if she is suddenly asked to leave the house early with him, he tells her that she should take more time to appreciate nature. On three mornings they leave the house together early. On the fourth morning, he leaves her behind – suspecting nothing – in the park and hides, armed with a pistol and a knife, in a house under construction. At about seven o'clock, he sees Faruk Taş approaching. He calls out to him, Faruk turns around, and stops. Akkaya walks up to him and says: "You have taken my honour, now I will take yours."² He then immediately fires

two shots at him. Faruk Taş falls to the ground. Akkaya walks up to him and, from two metres' distance, fires three more shots.

Akkaya doesn't want to waste any more bullets because he still needs them for Özlem. He pulls his knife from his pocket, undoes Faruk Taş's fly and cuts off his penis. Akkaya puts the penis and the knife in a plastic bag, and walks to a nearby ditch to wash the blood from his hands. He then rejoins his wife. Throwing the plastic bag and its contents at her, he says: "I've got what you're looking for." Akkaya later told the police: "She took the bag and looked into it. Then she looked at me. I aimed the gun at her, ready to fire. Then she shouted: 'Don't do it! Don't do it!' I fired three times. They were the last three bullets in the cartridge. Özlem turned to flee and then fell. I quickly put a second full cartridge into the gun. Özlem stood up again and I shot her a few more times."

Finally, he shoots her through the head from one metre away. He uses all the bullets that are left in the magazine. He checks to make sure that she is dead and then goes back home. He tells his 9-year-old son that he has killed his stepmother and that he will give himself up to the police. "I wanted to give myself up to the police because I committed the deed to save my honour and not because I'm a cowardly murderer." Akkaya is sentenced by the magistrate's court and the high court to 10 years' imprisonment for murder.

THE ALTUĞ CASE STUDY: 'CAR REPAIRS' (1976)³

Altuğ comes to the Netherlands in 1965. He is 41 years old and finds work as a cleaner. In 1974 his wife and three children (aged 18, 17, and 14) come to the Netherlands. The oldest and youngest are sons, named Mesut and Hikmet. The middle child is a daughter, named Mihriban. She has a cleaning job in the evenings, together with her friend, Idil Kalkan, who is 16. Idil's father, Hacı Hakkı Kalkan, ferries them to and from work. In the autumn of 1974, while taking Mihriban home, he has sexual relations with her. Mihriban describes it as rape.

Hacı Hakkı Kalkan then announces to all and sundry that he has been to bed with Mihriban. He even writes it in a letter to Altuğ, her father: 'I've been to bed with your daughter. She has a birthmark near her navel and is carrying my child.' Altuğ wants Kalkan to marry his daughter and take her as his second wife. He even offers Hacı Hakkı Kalkan 8000 guilders to marry Mihriban. Kalkan refuses, laughing. Altuğ then writes Kalkan a letter, threatening to kill him.

In the Netherlands, Mihriban marries Salep Albay, a boy from her native village who has not yet heard the gossip about what has happened. Once in

the Netherlands, however, he quickly learns his wife's history. Salep Albay immediately wants nothing more to do with Mihriban and returns to Turkey. The Altuğ family also leave quickly for Turkey. They try to return Mihriban to her husband, but he no longer wants her. The family comes back to the Netherlands, leaving Mihriban behind in Turkey. She is carrying Kalkan's child. That summer she has a miscarriage. Altuğ's sons in the Netherlands are subjected to questions like 'Is your sister still going to marry Kalkan?'

Akbulut, a friend of the family, applies pressure on the Altuğ family to kill Hacı Hakkı Kalkan. He says that, by doing nothing, they are making fools of themselves. Akbulut also tells everyone about the injury to their *namus*, so that the family is constantly reminded of it and they no longer dare appear in public. Akbulut talks to Mesut Altuğ (and probably to Altuğ as well) about how the honour killing should take place. Akbulut's house is decided on, and Akbulut will arrange for Hacı Hakkı Kalkan to be present. He will invite two non-Turkish mechanics, and inform Hacı Hakkı Kalkan that he can come to have his car looked at. Altuğ and a certain Coşkun (who will act as interpreter) will also be there with their cars.

When everyone is gathered on the appointed evening in Akbulut's living room, Mesut and Hikmet come to ask their father for money. When they have the money, Mesut shoots Hacı Hakkı Kalkan with a pistol. He falls to the ground, and Mesut fires a couple more times. Mesut leaves the building with his father and brother. Hacı Hakkı Kalkan is dead. Mesut Altuğ is sentenced by the magistrate's court and the high court to six years' imprisonment for murder.⁴

THE BARUT CASE STUDY: 'THE COUSIN WHO SHARES THE HOUSE' (1989)

Barut comes to the Netherlands in 1970, when he is 31 years old. He works for various companies as a welder until he is declared unfit for work in 1985, after which he receives a benefit. In 1971 he had arranged for his wife to be brought out to the Netherlands. Accompanying her were four children from Barut's first marriage: three sons (Kenan, Kerim and Kasım) and a daughter (Gül), as well as their own two sons, Cemil (1967) and Ertan (1968). Mrs. Barut had also been married before. She left her daughter, Emine (1953), and her sons, Ertuğrul and Temel, behind in Turkey. When they were grown up, however, the sons also settled in the Netherlands. In 1976, another child, a son, Cevdet, was born.

In 1973 Emine, Mrs. Barut's eldest child, marries Emin, a son of her fa-

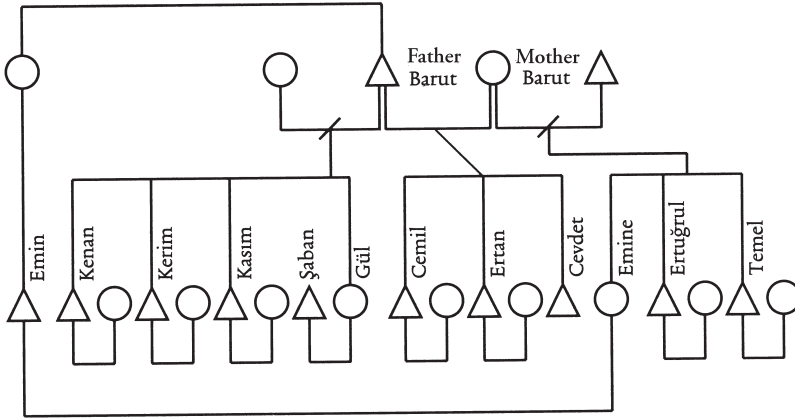

Fig. 12: The Barut case study

ther's sister. Barut brings them to the Netherlands, where they stay illegally, sharing a house with the Baruts. Living conditions must have been very cramped with so many children and the newly-weds, Emine and Emin, as well. Eighteen months later, Emine and Emin go to Turkey, so that Emin can work in his brother's painting business. In 1978, Mr. and Mrs. Barut also return to Turkey to set up their own engineering works. The venture fails because of a lack of orders and the frequent breakdown of machinery. In 1979, Mr. and Mrs. Barut return to the Netherlands, as do Emin and Emine, who move in with the Barut family until 1981. Emin works as a cleaner until 1981, when he is declared unfit for work and becomes a sickness beneficiary. The court records make no reference to any children of Emine and Emin. Because Emine and Emin also live in the house, the children all share rooms: the oldest three boys sleep in one room, and Cemil and Ertan (aged 12 and 11) sleep in another with their half-sister Gül, aged 13. The boys sleep in bunk beds, and Gül in a conventional bed.

During this period, Cemil and Ertan notice that their cousin Emin creeps into their room on several occasions and crawls into bed with Gül. At first they are unaware that the other has witnessed it too. Later, they talk about it together. They raise it with Emin, who makes rather vague excuses. Ertan discusses it with his mother, who seems to know about it, but asks him not to talk about it. The only ones who know nothing are the eldest three sons and Barut. Stepmother and daughter do not dare act because they are afraid of their son-in-law/cousin, whom they describe as large, strong and intimidating. A further reason for not bringing the matter out into the open

is the fact that Gül is destined to marry Şaban, a young man from their native village.

In 1987, Gül marries and moves to Turkey to live. All's well that ends well, it would seem. To judge by their visits to him, Cemil and Ertan have a reasonably good relationship with their cousin Emin. However, Ertan is unable to stomach what happened, as evidenced by the events of the 1988 summer holidays, when the Barut family return to their native village. One evening, after he has been drinking, Ertan goes to visit Gül (Ertan will later confess that he was a little drunk that evening). He sits in the kitchen with his half-sister and starts talking about what Emin did to her in the Netherlands. Initially Gül denies it, but when Ertan says that others in the family also knew about it, she admits to it. Gül's husband, Şaban, who is in the cellar, comes up at that very moment and hears part of the conversation. Threatening his wife with a knife, he makes her tell him everything. He is completely beside himself at the story and begins swearing and carrying on. He runs back to the cellar and tries to hang himself with a rope. Gül and Ertan manage to untie the noose just in time. Together they try to calm Şaban, but to no avail. Şaban goes to Emin's mother, who lives in the village. He utters all manner of curses at her. Now the entire village knows about what had happened. Barut also gets to hear the story. According to Kenan (Barut's eldest son), Şaban tells Ertan that unless he kills Emin to save the family honour, Şaban will commit suicide or else kill his wife, Gül.

The day after these dramatic events, the Barut family comes together. We do not know exactly who was present. Gül must have been there to explain what had happened between Emin and herself. She says that nothing happened. The Barut family return as soon as possible to the Netherlands. Barut will later say: "My honour was tarnished. I could not stay a day longer in Turkey. Something had to be done."

Back in the Netherlands, Barut talks to his sons, Kenan, Kerim and Kasım, all full brothers of Gül. Ertan is also present. Barut tells his sons that he can no longer live with the situation that has arisen. Barut tells the police that he told his sons that Emin must die, but that he would take care of it himself and did not want his sons to do anything. 'While I was busy planning, Ertan killed Emin,' he claims. More likely, is that Ertan was given the order at their meeting to kill Emin.

On several successive evenings, Ertan takes a pistol and waits several hours for Emin in the entrance hall to his block of flats. But Emin does not show up. Ertan suspects that he has caught wind of what is going on. Finally, Ertan sees Emin approaching the building. When Emin passes him in the entrance hall and goes up the stairs, Ertan fires at him. He then shoots him

once more in the head, before running away. He goes to his half-brother, Kenan, who hides the pistol for him.

The following day, the police find almost the entire Barut family gathered in mourning at the house of the deceased. Present are Mr. and Mrs. Barut, Kenan and his wife, Kerim and his wife, the widow Emine, Ertuğrul and his wife, Temel and his wife, Cemil and his wife, and also Ertan, the perpetrator. Emin's body is taken to Turkey for the funeral. Barut, the widow (Emine), and her full brother, Ertuğrul, go as well.

The following day Ertan is arrested by the police. The police had no difficulties identifying the culprit. Because he kept watch in the entrance hall for days, many people are able to provide a description of him.

THE GÜRSEL CASE STUDY: 'DISCHARGED FROM HOSPITAL' (1993)⁵

Fatma Gürsel has spent most of her childhood growing up in the Netherlands, when, on her sixteenth birthday, she is married off in Turkey. Six months later, she comes on a short visit to the Netherlands while her husband completes his military service in Turkey. Once in the Netherlands, however, she has no wish to return. She wants a divorce. The divorce goes ahead and Fatma stays in the Netherlands with her parents. More than four years later, Fatma runs off to join Mustafa, her Turkish boyfriend, whom she has met in the Netherlands. She moves in with him at a secret address in another town. Two of her uncles go to talk to Mustafa, making it clear that he must marry Fatma as quickly as possible. During the conversation, Mustafa tells the uncles that he is already married and that he has a child in Turkey. The Gürsel family find this difficult to accept, but nevertheless allow marriage negotiations to proceed. While these are in full swing, Fatma suddenly leaves her boyfriend and goes to her girlfriend, Emine. The reason for her departure is not known; all we know is that she became depressed because her father threatened her constantly with an honour killing.

When Mustafa discovers that Fatma has left him, he goes straight to Emine's house, where he suspects that Fatma is staying. It is the middle of the night when he arrives there. He is furious and demands to know from Emine, through the intercom, whether Fatma is staying with her. Emine says that she is, but that Fatma doesn't want to go back to him. Mustafa then tells Emine that he will tell Fatma's family bad things about Fatma. Fatma is completely shaken by this and says immediately: "I've got to leave here. They'll kill me. I'll go to Marieke, I'll be safe there." But her Dutch girlfriend Marieke doesn't answer the phone. Fatma can think of nowhere else to go.

In the morning, Fatma asks Emine to call Mustafa. Emine tells him that Fatma doesn't want to go back to him but has something to say to him, to which Mustafa replies that he wishes to have no more to do with her. He says that any woman who leaves him no longer exists for him and that she can go to hell as far as he is concerned.

That same day Mustafa telephones Fatma's older sister to tell her that Fatma has left him and has sought refuge with her friend Emine. On Thursday evening, Fatma attempts suicide in Emine's flat. She is taken to the hospital by ambulance. The ambulance has just left when Mustafa, furious again, is at the door. Emine tells him that Fatma is in hospital following a suicide attempt. Mustafa tells Emine that he will inform Fatma's parents. Emine hands Mustafa a suicide note from Fatma. Mustafa then drives to the home of Fatma's parents and speaks out on the street to Fatma's elder sister and the wife of Fatma's brother Ahmed. He then goes to the hospital and spends the rest of the night at her bedside. The following morning, Mustafa notices three people – Ahmed (Fatma's brother), Ahmed's 29-year-old first cousin on his mother's side, and someone else he does not know – hanging around suspiciously near the entrance to the hospital casualty department.

Fatma and Mustafa leave the hospital in the afternoon. When they reach Mustafa's car, Fatma is shot dead by her thirty-year-old brother, Ahmed Gürsel, who is known to be a quiet type. He doesn't shoot Mustafa. When Fatma is already on the ground, Ahmed fires at her several more times. A nurse rushes up to give first aid, but Ahmed prevents him. "She has to die", he says. Ahmed stands near his sister, smoking a cigarette and waiting for the police to come and arrest him. He is sentenced to 10 years in prison for murder.

THE KOPARAN CASE STUDY: 'HANGING AROUND THE FLAT' (1985)

Twenty-six-year-old Koparan emigrates from Central Anatolia to the Netherlands in 1970. Five years later, he has his wife and children (two daughters and a son) brought over to the Netherlands. He is declared unfit for work in 1980 and receives a benefit. From that time on, he spends his time doing volunteer work for the local radio station. He has a radio programme for Turkish compatriots, providing information on the Netherlands and Turkey, which he acquires through wide reading. His Dutch is good: he even acts as interpreter for the police. His best friend is Gürdal, whom he met in the Netherlands. Gürdal is ten years older than him and comes from a village in Izmir province. They frequent a Turkish coffee-house together, and the two families are regular visitors to one another's homes.

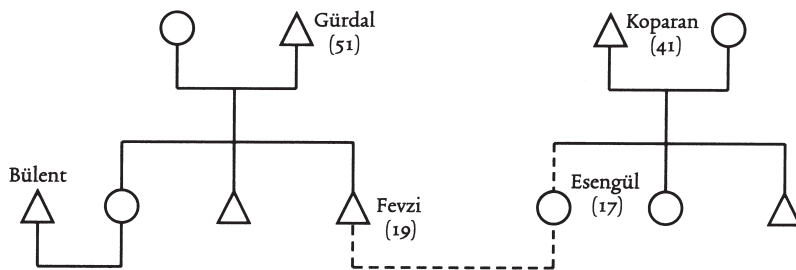

Fig. 13: The Koparan case study

In 1984, Koparan’s eldest daughter, 17-year-old Esengül, starts ‘going out’ (to use her own words) with Fevzi, Gürdal’s 19-year-old youngest son. ‘Going out’ is a somewhat exaggerated term for what actually happens: Fevzi phones her occasionally and sometimes they arrange to meet at Esengül’s school. When Fevzi tells Esengül that he wants to ask her father for her hand, she agrees. On Esengül’s eighteenth birthday, Gürdal asks Koparan through an intermediary for Esengül’s hand for his son Fevzi. However, Koparan says that he has no daughter to give away. After that, Koparan and Gürdal stop talking to one another and break off all contact: in other words, they are ‘küs’. Each blames the other for the situation that has arisen.

Koparan manages to persuade his daughter Esengül that she is much too young to marry. He reminds her of her wish to learn the hairdressing trade. Fevzi does not leave Esengül in peace. He waits for her outside school and parks his car outside the Koparan’s flat, with the radio blaring. He also sits in the entrance hall of their block of flats. Koparan speaks to Fevzi several times about it and asks him to stay away from the flat, but Fevzi claims that he comes there for his friend, Mehmet Beyaz, who also lives in the building and who plays in the same band.

Koparan phones Gürdal repeatedly to ask him to keep his son away from their apartment, but Gürdal refuses. Later, Koparan tells the police what Gürdal’s response was: “He said that there were many of him and just one of me. If he came to fuck my wife, I couldn’t do anything. He said that I wouldn’t dare come to his neighbourhood. He also said that he never went out ‘without one.’ I thought that by that he meant a gun or a knife.”⁶ According to Koparan, Gürdal had said: “My son can do what he likes. He can visit a prostitute, but your daughter is one too. My son can simply fuck your daughter in the street”, and had asked “whether I went to bed with my own daugh-

ter because I was so keen to hang on to her. He said that he would tell his son to come along more often to harass me even more.”

Fevzi starts harassing Esengül outside her school. Showing her a gun, he tells her that he cannot live without her. Esengül says: “I was afraid that he was going to do something to himself. Or perhaps he wanted to frighten me into going with him.” As a result of the conflict between the two families, the Koparans no longer attend weddings within the Turkish community because Fevzi and his band play at such occasions. Koparan, who wants to avoid trouble, prefers to stay away. Esengül is approached at various times by Fevzi. One day, Koparan keeps watch at school. When he sees Fevzi, he chases him away with a piece of wood. On one occasion, Koparan phones the neighbourhood policeman to ask him to stop Gürdal from harassing Esengül. When the policeman phones Gürdal, Gürdal calls Koparan immediately afterwards and threatens him: “I know your movements exactly and I’ll get you one of these days.”

Four days later, there is a Turkish celebration in the community centre. Koparan attends in his capacity as reporter for the local radio. Later, at the police station, he describes what happened: “Gürdal and his son-in-law Bülent came up to me and demanded that I step outside with them to talk. I didn’t want to but they persisted and, because I didn’t want to cause problems for others, I went with them. Once outside, they threatened to kill me, saying: ‘You’re not going to leave here alive. Your end has come.’ And Gürdal said: ‘Why are you standing in the way of my son? You should keep your prostitute to yourself.’ He also said: ‘Your end has come. You can’t sleep with your daughter anymore. My son, my son-in-law and I are going to fuck your daughter and your wife.’ For a Turk, hearing that is the equivalent of a bullet. I got scared and wanted to get away. But they stopped me and then both of them hit me. Gürdal came at me with a knife. Meanwhile, I heard someone shout for a gun to be fetched from inside. I thought that Gürdal’s wife, who was inside, had one with her. I panicked and pulled out my screwdriver. Gürdal stumbled and I grabbed his knife. That may be when I stabbed Gürdal and Bülent.”

Koparan rushes home and tells his wife and daughters what has happened. They begin to cry and Esengül starts screaming. Koparan then calls the police and four police officers come to pick him up. Gürdal dies as a result of the stab wounds; Bülent is only slightly wounded. Koparan is sentenced to two years’ imprisonment for causing grievous bodily harm leading to death.

THE ŞENGÜL CASE STUDY: 'STONES IN THE GARDEN' (1972)

Şengül comes to the Netherlands from southern Turkey in 1965 as a guest worker, leaving behind his wife and children (a nine-year-old girl and five sons aged between three and eight). They live on the outskirts of a city, in an old dilapidated house with no water or electricity. In the Netherlands, Şengül sees a lot of Çağman, who comes from the same town. Çağman does not want to stay in the Netherlands, however, and after a year returns to his wife and five children in Turkey. In the summer of 1968, Şengül asks Çağman to keep an eye on his family while he is in the Netherlands. This entails Çağman helping Mrs. Şengül to raise the children. After a time, however, they begin a relationship. In the summer of 1969, Mrs. Şengül tells her husband that she has had enough of the ramshackle house and wants to move. He finally agrees and Çağman helps with the shift.

Çağman has arranged for her to move into a house in his street. With Çağman staying at Mrs. Şengül's house until late in the evenings, the entire neighbourhood becomes aware of their relationship. The neighbours turn against them. They throw stones into Mrs. Şengül's garden and on one occasion even drag Çağman out of her house.

The two eldest sons, Hasan aged twelve and Ibrahim aged eleven, are told that they have to act. But when Ibrahim tells Çağman to leave their house, Çağman becomes so angry that he hits Ibrahim and pushes him outside. Ibrahim is forced to sleep in a neighbour's scullery. When Şengül comes on holiday in the summer of 1970, Ibrahim is able to sleep at home once again. That entire summer Şengül hears nothing of what has happened: people are too afraid to tell him anything. At the end of the summer, Çağman goes to the Netherlands with Şengül (perhaps his finances are at rock bottom, or he is no longer welcome in the street). They both go to live in what is called 'the Turkish camp' – a group of barracks that accommodate Turkish men whose wives and children still live in Turkey.

In the summer of 1971, Şengül and Çağman both go to Turkey on holiday. One evening Mrs. Şengül tells her children that she is going to the hairdressers, but she does not return. The children become desperate and don't know what to do. They cannot contact their father, who has "gone out in another town" (in actual fact, he is visiting a brothel). He comes home just before daybreak and hears from the children what has happened. Şengül searches everywhere for his wife but cannot find her. Two days later, Çağman's wife tells him he can stop looking: her husband and his wife have gone off together to the Netherlands. Şengül immediately sends a telegram to the barracks. The Turks there inform the police and Mrs. Şengül is intercepted at the border. She then goes to relatives in Germany, while Çağman

goes to the barracks. However, the Turks in the barracks do not want him living there. Çağman is forced to move to another town in the Netherlands to live and find work.

Şengül also returns to the Netherlands to follow a course of treatment for a lung condition. Once here, he discovers that his wife and Çağman are both back in Turkey. He returns at once. His wife and Çağman are both in custody at the police station on the grounds of adultery. They are released two days later because Şengül does not wish to press charges.

Both Şengül and Çağman return to the Netherlands. In January 1972, Çağman goes to Turkey to celebrate the Feast of Sacrifice. Completely distraught, he goes into the living room where Mrs. Şengül and her children are and tells them to shoot him. With great difficulty, Mrs. Şengül manages to get Çağman out of the house. He seems to be in no hurry to return to the Netherlands and continues to harass Mrs. Şengül. She is also harassed by her brothers, who threaten to kill her. She therefore urges her husband to allow her to come to the Netherlands. In the spring of 1972, Şengül goes into debt to buy a house in the Netherlands, and his wife and children arrive that summer. Only the eldest daughter, aged sixteen, stays behind in Turkey, where she lives with her grandparents.

A few days before the departure of Mrs. Şengül and her children, Çağman comes to the Netherlands as well, leaving his wife and children behind in Turkey. Three days after their arrival in the Netherlands, Çağman comes to the door asking to speak to Mrs. Şengül. He starts coming to the door every Saturday and Sunday (during the week he works in another town). When the children open the door, he tells them that he wants their mother and that they should go to their father's. The children lie, telling him that their mother cannot leave her husband because she does not have an independent residence permit. Çağman is so persistent that the children eventually give him a date. They say that their mother will be granted her own residence permit on a certain day in autumn. Çağman says that he will come to their house between four and five o'clock in the afternoon of that day and take their mother with him.

On the appointed day, Ibrahim stays home from school. He will tell the police later that he told his father, who is at home on a sickness benefit, that he was sick. However, Ibrahim becomes restless and at a quarter to four he goes to the factory where his mother works. When he sees Çağman and his mother near the factory, he rushes up to them. Çağman is furious with Ibrahim and walks on briskly with Mrs. Şengül on his arm. Through gestures, Mrs. Şengül makes it clear to Ibrahim that Çağman has an enormous butcher's knife and that he is forcing her to accompany him. Çağman tells Ibrahim that he will give him five guilders if he goes away, to which Ibrahim

replies: “Even if you gave me the whole of the Netherlands, I would still go with my mother.” Ibrahim then rolls a cigarette. When he has smoked half of it, he drops it on the ground. Still playing the parental role, Çağman says angrily: “Pick it up. Soon you’ll be out of money again and will have no tobacco.”

However, Ibrahim has dropped the cigarette deliberately. When picking it up, he plans to surreptitiously take the gun that he has brought with him from the inside pocket of his coat. Ibrahim will later tell the police: ‘I felt as if Çağman might pull out his knife at any moment to kill me and my mother.’ Ibrahim holds the gun behind his back and drops back a little so that he is walking slightly behind his mother and Çağman. He then steps directly behind Çağman and fires three shots into Çağman’s back. Çağman collapses and lies, partly on his back, on the street. He swears at Ibrahim: “I’ll go to bed with your mother and sister one more time,” and “I was planning to kill you,” to which Ibrahim replies: “Oh, is that what you think?” He pulls out his gun for the second time and fires three more shots at Çağman.

Ibrahim flees to the Turkish barracks. He then goes to the community centre, where he knows he will find his older brother Hasan. They decide that Ibrahim should give himself up to the police that evening, but when they walk home together, the police are already waiting at the door.

Çağman does not survive the honour killing. The police find a 25-centimetre long butcher’s knife on his body.

Appendix II. Case studies from Bitlis province

The two honour killings and the two alternatives to honour killings reported below took place in Bitlis province in southeastern Turkey. They were recorded for me in October 1994 by the *kültür müdürü* (director of culture) of that province, who was assigned the task by Osman Badraslı, the then provincial governor. Osman Badraslı, who died in 1995, was my husband's *dayı* (mother's brother). Unfortunately, it is not clear whether these case studies involved Turks or Kurds. I have translated the case studies as literally as possible from Turkish.

BITLIS I: 'SEVEN BANDITS RAPE THE DAUGHTER-IN-LAW'

Informant: "In the 1940s, seven bandits stay the night at the house of an old man in one of our villages. Also present are his daughter-in-law and her three children. His son is away on military service. At night the bandits seize the daughter-in-law. Her screams wake her father-in-law. The robbers beat him and tie him to a post. The robbers defile the daughter-in-law in front of the old man. When the robbers leave the village, the daughter-in-law is semi-conscious, and the father-in-law exhausted and helpless. The old man says: 'Daughter, it is not your fault. Allah will forgive you. I saw nothing. You are my daughter, you are my dear one,' but the daughter-in-law replies: 'Father, I cannot live with this stain. How can I ever again look you and my children in the face?' and she goes weeping to the stable, where she hangs herself. As soon as the villagers hear of the tragic incident, they take up arms and pursue the robbers. They kill all seven of them. In our district, where wickedness does not go unpunished, such a terrible incident has never happened again."

BITLIS 2: 'REPUTATION IS ATTACKED'

Informant: "The incident took place about twenty-five years ago [1970] in one of the villages near the capital. A newly-married woman cheats on her husband. When he finds out about it, he is horrified, as the young villager whom his wife has taken up with is very strong [güçlü]. Tackling him would mean the end of himself and his family. He therefore devises a plan. He takes his wife to her parents' village. In the quiet river valley between the two villages, he ties up his wife's hands and tells her that he knows what is going on and that he does not have the strength to endure it any longer. He says: 'You have brought shame upon me in front of the villagers; I can no longer look anyone in the face. From now on, you won't look anyone in the face either. To remind you every single minute of the disgrace you have brought upon me, I will leave a mark on you.' The husband then pulls out a razor from his pocket and cuts off his wife's nose. The wife, who is completely covered in blood, starts moaning with pain. The man flees to Istanbul, leaving his wife behind. The couple divorce and each marries again. In her new marriage, the woman whose nose has been cut off lives with the hard lesson she has learned."

BITLIS 3: 'THE SHEPHERD FINDS THE BODY'

Informant: "This incident occurred a couple of years ago. Whenever her husband is away from home, a married woman with two children takes advantage of the opportunity to go out with other men. Everyone talks about her. The woman's brothers and other relatives apply pressure on her husband to call her to order. They even beat him, but to no avail. The brothers, who live in terrible anguish now that their sister's immoral conduct is known, can no longer show their faces in the community. They decide to eliminate their sister and purify their honour. One night, without anyone noticing, the three brothers collect their sister from her house and take her to an empty stable. The youngest brother tries to strangle his sister, but because she is his sister, his hands begin to tremble and he starts crying. This annoys his older brother, who hits him and strangles his sister by pulling the rope tight. The three brothers bury their sister in the mountains and return home. They spread word that their sister has run off with a soldier.

Fifteen to twenty days pass before a shepherd's dog smells the body in the mountains and begins scratching at the spot. The shepherd removes the stones, sees the body and recognises the girl. The brothers learn of it that evening. They rebury her secretly somewhere else, thereby putting an end to

the matter. The brothers breathe with relief because the namus of the family has been purified; they can show their faces in the community once again. May Allah ensure that no one else shares her fate.”

BITLIS 4: ‘FIGHTS FOLLOWING AN ELOPEMENT’

Informant: “Arranged marriages are still a widespread practice in our provincial capital and in our villages. That is what happens in this incident. The girl’s heart, however, belongs to someone else, so she flees one night to her young man. All searches are in vain. The girl and the boy have disappeared without trace, but because people know who the boy is, the girl’s family storm into his family’s house. A fight ensues with sticks and stones and some people are injured. The case is brought to the police. Finally, influential elders succeed in bringing both parties to an agreement. Meanwhile, the party to whom the girl is engaged levels accusations at the girl’s family. A dispute develops between the two parties. Because manpower is so important in our area, the party to whom the girl is engaged must accept peace because they do not have many men in the family. The presents they had already given are returned, and because this is a dishonourable matter (‘onur kırıcı’) here, it is hard for the family to continue living in Bitlis. They move to Istanbul.

Negotiations between the girl’s family and her boyfriend’s family continue, but because of what has happened, the girl is no longer accepted as a child of her family (‘evlatlıktan reddedilir’). She marries her boyfriend, but she can no longer enter her father’s house.”

Appendix III. The Turkish Criminal Code (TCK) and honour killing

The penalty for deliberate murder is a ‘severe’ prison sentence of 24 to 30 years (section 448 TCK).⁷ Sections 449 and 450 TCK outline aggravating circumstances that extend the period of detention. Murdering a relative is one such circumstance. Section 449/1 TCK reads: “If the homicide is committed against one’s wife, husband, brother, sister, adopted parents, adopted child, step-mother, step-father, step-son or daughter, father-in-law, mother-in-law, son-in-law, or daughter-in-law the perpetrator shall be punished by heavy imprisonment for life.”

A further aggravating circumstance is murder in the context of blood revenge (TCK 450/10), an offence that carries the death penalty.⁸ Sections 453 and 462 TCK provide for sentence reduction in the case of murder/manslaughter for reasons of honour. Sections 472 and 453 TCK are interrelated. For honour killing incidents not covered by these sections, the judge invokes the general sections 51 and 59 of the Turkish Criminal Code. The specific wording of the sections referred to here is as follows:

SECTION 453 TCK

Kasten katil cürmü failin veya karısının yahut anasının veya kızının veya torununun yahut kız evlâtlığının veya kız kardeşinin haysiyet ve namusunu kurtarmak için, yeni doğmuş çocuk aleyhine işlenmiş ise, fail beş seneden on seneye kadar ağır hapisle cezalandırılır.

Translation: ⁹ Where the act of killing is maliciously committed against a newly born child with the purpose of protecting the dignity and reputation of the offender or of his wife, mother, daughter, grandchild, adopted daughter or sister, the offender shall be punished by heavy imprisonment for five to ten years.

In 1991, this section was amended to the following: Öldürme fiili, anası tarafından şerefini kurtarmak saikiyle yeni doğmuş bulunan çocuğa karşı işlenmiş ise faile dört yıldan sekiz yıla kadar hapis cezası verilir.

Translation: If a mother kills her newborn baby in order to save her şeref, she shall be subject to a prison sentence of 4 to 8 years.

SECTION 462 TCK

Yukarıda geçen iki fasılda beyan olunan fiiller, zinayı icra halinde veya gayrimeşru cinsî münasebette bulunduğu esnada meşhuden yakalanan veya zina yapmak veya gayrimeşru cinsî münasebette bulunmak üzere yahut henüz zina yapmış veya gayrimeşru cinsî münasebette bulunmuş olduğunda zevahire göre şüphe edilmeyecek surete görünen bir koca veya karı yahut kız kardeş veya fürudan biri yahut bunların müşterek faili veya her ikisi aleyhinde karı veya koca yahut usulden biri veya erkek veya kız kardeş tarafından işlenmiş olursa fiilin muayyen olan cezası sekizde bire indirilir ve ağır hapis cezası hapis cezasına tahvil olunur.

Müebbet ağır hapis cezası yerine dört seneden sekiz seneye ve idam cezası yerine de beş seneden on seneye kadar hapis cezası verilir.

Translation: As regards perpetrators who commit the offenses specified in the two foregoing chapters, against the wife, husband, sister or offspring, at the time the victim is caught while in the act of adultery or illegal sexual intercourse, or while the victim was about to commit adultery or about to engage in illegal sexual intercourse, or while the victim was in a situation showing, free from any doubt, that he or she has just completed the act of adultery or illegal sexual intercourse; or against another person caught participating in such acts with one of the aforesaid relatives, or against both, the punishment prescribed for the offense shall be reduced to one eighth and heavy imprisonment shall be commuted to imprisonment. In lieu of heavy life imprisonment, imprisonment for four to eight years, and in lieu of death, imprisonment for five to ten years shall be imposed.

Section 472 TCK is described in the chapter on induced miscarriages. Section 468 TCK stipulates a 'severe' sentence of seven to ten years' imprisonment for an induced miscarriage or abortion that takes place against the mother's will. If the induced miscarriage or abortion occurs with the mother's consent, the penalty is two to five years' imprisonment, and the

woman herself is also subject to the same prison sentence. The following amendment has been made to section 472 TCK:

SECTION 472 TCK

[Çocuk düşürme, düşürtme cürümleri] kendisinin veya akrabasının şeref ve namusunu kurtarmak için işlenmiş ise verilecek ceza yarıdan üçte ikiye kadar indirilir.

Translation: If a miscarriage is induced to save the şeref and namus of the woman or her relations, the sentence shall be reduced by one half to two thirds.

The two general sections read as follows:

SECTION 51 TCK

Bir kimse, haksız bir tahrikin husule getirdiği gazap veya şedit bir elemin tesiri altında bir suç işler ve bu suç ölüm cezasını müstelzim bulunursa, müebbet ağır hapis cezasına ve müebbet ağır hapis cezasını müstelzim bulunursa yirmidört sene ağır hapis cezasına mahkûm olur. Sair hallerde işlenen suçun cezasının dörtte biri indirilir.

Tahrik ağır ve şiddetli olursa ölüm cezası yerine yirmi dört sene ve müebbet ağır hapis cezası yerine on beş seneden aşağı olmamak üzere ağır hapis cezası verilir. Sair cezaların yarısından üçte ikisine kadarı indirilir.

Translation: If a person commits a crime in the heat of anger or under influence of a strong grief caused by an unjust provocation, he shall be punished, if the punishment of death is prescribed for the crime, by heavy life imprisonment; and if heavy life imprisonment is prescribed for the crime, by heavy imprisonment for twenty-four years. In other cases the punishment prescribed for the crime shall be reduced by one fourth.

Where the provocation is grievous and severe, heavy imprisonment for twenty-four years shall be imposed instead of punishment by death, and heavy imprisonment for not less than fifteen years shall be imposed instead of heavy life imprisonment. Other punishment shall be reduced by one half to two thirds.

SECTION 59 TCK

Kanunî tahfif sebeplerinden ayrı olarak Mahkemece her zaman fail lehine cezayı hafifletecek takdirî sebepler kabul edilirse, idam cezası yerine müebbet ağır hapis ve müebbet ağır hapis yerine otuz sene ağır hapis cezası hükmolunur. Diğer cezalar altıda birden fazla olmamak üzere indirilir.

Translation: Apart from statutory matters of mitigation, wherever discretionary matters of extenuation in favor of the offender are accepted by the court, heavy imprisonment for life, instead of death, and heavy imprisonment for thirty years, instead of heavy imprisonment for life, shall be imposed. Other punishments shall be reduced by not more than one sixth.

The Criminal Code¹² goes on to explain that the circumstances in which section 59 may be applied are not specified in the legislation. The law allows judges considerable freedom to apply this section as they see fit. The purpose of section 59 is to examine each case on its own merits and to take into account the character of the offender. In the case of honour killings, I see this section as supplementing section 51 in the following way: where there is no question of provocation or great suffering, the court may reduce the sentence if it believes that this is warranted. Research into Turkish case law is required to demonstrate whether the section is in fact interpreted in this way.

Notes

Notes to Introduction

- 1 This refers to migrants from Turkey, regardless of their ethnicity. The court records and Turkish newspaper articles often do not specify whether Turks, Kurds, Circassians or others are involved.
- 2 The stress is on the first syllable.
- 3 Ergil's study (1980b: 216) showed that no honour killers came from the upper social classes. Of the 273 honour killers in Izmir, Istanbul and Ankara, 89% came from the lower classes and 11% from the middle class.
- 4 This word also means 'honour killing'.
- 5 Honour killing cases appearing before the Court of Appeal are reported here.
- 6 Turkish does not distinguish between blood revenge and blood feud; both are called *kan davası*. In English, a single retaliatory killing is 'blood revenge', and a chain of such killings is a 'blood feud'.
- 7 This was the European edition of the *Hürriyet* in the years 1992, 1993 and 1994. Thanks to Dick Koopman, the bound volumes of the *Hürriyet* (currently up to 1994) are available in the University Library at Leiden (1998 is the last volume to be bound). The content of the European edition is usually the same as the Turkish one, with the exception of a few pages of regional news. This means that the two editions may report a differing number of honour killing incidents. The *Hürriyet* is the equivalent of a Turkish *Daily Telegraph*, unlike the *Cumhuriyet*, which more closely resembles *The Times* and which rarely reports on honour killings. See Bovenkerk and Yeşilgöz (1998: 38-39) on the subject of Turkish newspapers in Europe. The Turkish *Hürriyet* almost certainly does not give an exhaustive account of all honour killings.
- 8 Ergil (1980b: 203-248). Ergil reports that he had initially intended to study honour killings in both villages and cities, but that it was not possible to recover incidents of honour killings from the records of the provincial police. He therefore confined himself to honour killings in the three major cities – Ankara, Izmir and Istanbul.

bul. By examining police records from the period 1970-1975, he arrived at a total of 273 honour killings (*namus cinayeti*). The aim of his research was to demonstrate that honour killing was primarily a lower-class phenomenon. Although Ergil lists many percentages (e.g. honour killers who are minors, female versus male victims, etc.), he unfortunately does not cite a single case study. 'Honour killing' is presented as a generally understood concept. Only through his very brief descriptions do we have some inkling of what he understands by honour killing. It is a very broad category. For example, he includes the case of a retired military man (*albay*) who, when given a dirty shirt by his wife, proceeds to argue with her, and then grabs his gun and shoots her (Ergil 1980b: 232). Even though Ergil writes *bunu bir şeref meselesi yapan albay* (the *albay* who made a *şeref* issue out of this), he nevertheless classifies this case as an honour killing (*namus cinayeti*). It is difficult to evaluate Ergil's percentages because he does not report what actually happened in the other 'honour killings'.

- 9 In 1978, an article by Van Dijken and Nauta on an honour killing incident involving Turks in the Netherlands appeared in the *Algemeen Politieblad*. In 1983, two undergraduate theses were published on honour killings among Turks in the Netherlands, one by Van der Molen (from the police academy) and the other by Gosewehr and Verheijden (both lawyers). In addition, Yücel Yeşilgöz, a criminologist, has written two articles about Turkish honour and honour killings and his doctoral dissertation includes two case studies on the subject.
- 10 Ginat (1979) describes six honour-killing case studies, and investigates why honour killing was resorted to in each case.
- 11 Kressel (1981) presents four case studies of honour killings, and presents a summary of 24 characteristics.
- 12 Safilios-Rothschild (1969) based her research on Greek newspaper articles about honour killings, investigating the kind of honour killings that were committed.
- 13 Judicial bodies are not in a position to provide a survey of honour killings as these killings are not recorded as such. I went to the Central Judicial Archives in Almelo, which registers all crimes and misdemeanours committed in the Netherlands by foreigners (i.e. those born abroad). The information is held until the accused is eighty years old. In 1995, the record system contained a total of 50, 683 records on Turks, of which 23, 397 could be accessed. The remaining 27, 286 records are in the computer, but this is no more than an

“automated filing system”. Although it is possible to consult each record individually, this would be a laborious process. As it would have taken me nine months to work my way through all the records, I did not attempt it. Another reason was that they would not have provided a complete picture of honour killings in any case, as Turks born in the Netherlands are not included in the records. At the start of my research in 1995, a printout was made for me from the records I did consult, with correlations for country of birth (Turkey) and instances of murder/manslaughter. This produced 103 prosecution numbers for the years 1972-1993. Armed with these numbers, I went to the court archives to check the records to see whether honour killings were involved. If the case went to appeal, I was able to find the records at a magistrate’s court (and the prosecution number became a sentence number). It was no easy task to search for this new number. Eventually, I was able to break down the 103 cases of murder/manslaughter as follows: 30 honour killings, 37 cases of murder/manslaughter with *şeref* as a motive (usually bar fights), 5 drug-related offences, 10 dismissals, 2 cases of destroyed files, 1 blood revenge, 4 lost files, 2 files that were not yet in the archives as the case was still open, and 12 files that I did not examine. It was not always easy to assign a file to a particular category (see 5.6). One way of gaining an overview of honour killings – but not a course adopted by me – is to use the Police Recognition System (HKS), which registers cases of murder/manslaughter per region. As there are 20 regions, this would be very time-consuming. HKS, which has been operational nation-wide since 1990, only came into existence in 1982, which means that it cannot provide a complete survey of honour killings since the 1970s.

- 14 One case not included here is discussed in Van Eck 2000d. See chapter 3, footnote 23.
- 15 Appendix 1 contains six case studies, which I refer to for specific aspects only.
- 16 The 1988 Danish documentary, *Den sagtmodige morder* (The quiet killer) by Poul Martinsen, which deals with the honour killing of Gülsüme Çağlar, a 31-year-old Turkish/Kurdish woman in 1986. Two other documentaries on honour killings have appeared: the German documentary, *Warum habe ich meine Tochter getötet?* by Hans-Dieter Grabe, about the killing in 1983 of Perihan Yaku-boğlu, a 23-year-old Turkish woman (broadcast by the ZDF in 1986), and the Belgian documentary, *De eer is gered* [Honour saved]

- by Dominique Torres, about the 1993 killing of Nazmiye İlkpınar, a 15-year-old Turkish girl, in Colmar, France. See Hermet 1997.
- 17 Wiersinga (1993: 541) points out that there is no need for expert witnesses to make legal presentations; if the law is not their area of expertise, this can detract from the quality of their testimony.
- 18 I have occasionally altered European localities and the number of children in a family in order to reduce the chances of recognition. The names of Turkish villages have all been changed. I have not altered the names and places in the *Hürriyet* articles and the documentary as these have already been publicised.
- 19 Den Exter (1993: 29) makes a plea for the region of origin to be given consideration in research into migrant communities.
- 20 The 30 cases of honour killings I found in the court records break down as follows: five from the 1970s, 11 from the 1980s, and 14 from the years 1990-1993. These figures do not necessarily point to an increase in the number of honour killings. The 1990 killings may simply have been easier to identify than the earlier ones.
- 21 This is also disadvantageous for the judiciary, which prefers to have more information about the background and motives of suspects. It is important for police officers to construct a 'social map' of the perpetrator's social environment so that potential accomplices are not overlooked.

Notes to Chapter 1

- 1 Cf. Van Eck 1997a.
- 2 Meeker 1976: 244; Abu-Lughod 1986: 55; Holy 1989: 122-123. Does this apply to Kurds as well? Yalçın-Heckmann (1991: 212) says of the Kurds in Hakkari Province: 'A woman's sexuality has to be under the control of someone other than herself, and until marriage, the protection is given to her nearest male kin, i.e. her father, brother(s), and her father's brother and FBSs when necessary. After marriage, the control of her sexuality is partly transferred to her husband.'
- 3 See the case studies 'The wrong person is killed' and Bitlis 3.
- 4 As happened in the Türkmen and Çetin case studies.
- 5 Pronounced 'sheref', with the stress on the second syllable.
- 6 Meeker (1978: 261): "To talk about a man's sharaf requires some kind of explanation: 'What kind of sharaf and what is its special sig-

- nificance?’ There is no more to be said about his *namus* than that he has it or he does not.”
- 7 Women may also claim these honorary titles. Delaney (1990: 520) reports that the *hac* confers status, at least for a man. Thereafter, a man is always addressed as *hac1*, followed by his first name. This does not apply to women. People do say of her that she is *hac1* (has visited Mecca), but she is not addressed in this way. Delaney (1990: 520) also writes: ‘For a woman hajji [= *hac1*], there are no outward signs of changed status.’
 - 8 Meeker (1976: 260): ‘*Namus* is said by the people of Of [a district of Trabzon], in no uncertain terms, to be a part of and included within *sharaf* [= *1eref*].’
 - 9 Ergil (1980b: 193) writes: ‘It is important to emphasise that among the lower classes, the *namus* proportion within *şeref* is much greater than for the middle class, and for the latter it is greater than for the upper-class.’
 - 10 Meeker (1976) notes an interesting distinction between his findings and those of Pitt-Rivers (1966). Pitt-Rivers, who conducted his research in Spain, came to the conclusion that people of high status (considerable *şeref*) barely needed to concern themselves with their *namus* (Meeker 1976: 263). Meeker’s findings with regard to Turkey, however, were that the more *şeref* a man had, the more vital it was to keep his *namus* intact: ‘The later Ottoman sultans, in particular, were preoccupied with elaborate statements about their *namus* [...]. His *sharaf* does not exempt him from the problem of *namus*; on the contrary it requires more elaborate statements of *namus*. [...]. In Of, an agha will be more attentive to the statement of his *namus* than the brother of an agha. These two men will be more attentive than other men of their lineage. The latter lineage will be more attentive than other lineages of the clan [...]. In other words, the more *sharaf* a person or collectivity acquires, the more “public-viewed” the person or collectivity becomes [...]. Being more “public-viewed” then results in the tendency to state more scrupulously one’s attachment to the common static standard, that is, *namus*’ (Meeker 1976: 266). Meeker is unable to explain this distinction; he simply notes it: ‘With only the hope that doubt will be left in the place of a former satisfying, but illusory, certainty’ (Meeker 1976: 267). A possible explanation is that the people of high status in Pitt-Rivers’ study are not dependent on their community, while those in Meeker’s study are. One example is the sultan, who owes his position to the good grace of his people. If he loses

their support, he forfeits his right to the sultanate. An example of an *aga* who attaches considerable importance to his *namus* is the one in *Reşo Ağā*, a story by Bekir Yıldız (see 2.1). A businessman with national or international dealings is not dependent on the community in which he lives. See also 1.5 on the question of those for whom *namus* is important.

- 11 Meeker 1976; Petersen 1985: 55; Schiffauer 1986: 3; Delaney 1987.
- 12 These are Turkish women who have come to the Netherlands because of marriage and who come from villages in the Black Sea region and Gaziantep.
- 13 Delaney (1987: 42) also claims that 'being married' confers status upon a woman. However, she does not use the term *şeref*.
- 14 For an educated Turkish woman, her position in the work force makes up a substantial part of her *şeref*. It is common in Turkey for educated urban women to work full-time in professions that have long included engineers and lawyers (Öncü 1981). The discussion about *namus* and *şeref* in this section, however, is based on Turkish village culture. I have taken this as my point of departure because honour killings occur among this group and not among the Turkish urban elite.
- 15 cf. Delaney 1987: 35, Brandes 1987: 125.
- 16 Meeker 1976: 244.
- 17 Ginat 1979: 182.
- 18 Meeker (1976: 384 note 4): 'Among the Turks, the word *ırz*, which is derived from the Arabic 'ard, refers specifically to a woman's chastity.' Meeker does point out, however, that the semantic boundaries differ slightly. Arabic contains other words for honour as well. Bourdieu (1979: 117) cites the Arabic terms *nif en hurma* that are used in Northern Africa. He translates *hurma* as 'honour', with the meaning of *namus*. *Nif*, he translates as 'point of honour', with the meaning of *şeref*. The semantic boundaries may differ here as well.
- 19 These words (*haysiyet*, *iffet*, *onur*, *gurur*) are also used for women.
- 20 Everaert (1993: 31) is the exception. Oddly, he translates *şeref* as 'family honour' and *namus* as 'honour'.
- 21 Magnarella 1982: 396, Schiffauer 1983: 65.
- 22 Atabek (no date, 70) writes of Turkish society: 'A man who does not permit his wife to work or go out alone will not be criticised by society. On the contrary, such a man represents the type of man of whom many women and men approve.'

- 23 See also Asena (1987: 138-139): "Gül rattled excitedly, 'Sweetheart, he doesn't let me go on Sundays.' She says it proudly."
- 24 Schiffauer (1986: 16).
- 25 Bourdieu 1979: 17; 1979: 18; 1979: 120; 1979: 115. Based on Bourdieu's description of the terms *hurma* and *nif*, I have translated them as the Turkish honour terms *namus* and *şeref*, respectively. They may not be exact semantic equivalents.
- 26 A Turkish synonym is *itibar*.
- 27 Schiffauer (1983: 67). See also Abu-Lughod (1986: 166): 'Men's positions in the hierarchy are validated by the voluntary deference shown them by their dependants, withdrawal of this respect challenges men's authority and undermines their positions.'
- 28 Starr 1978: 56; Bourdieu 1979: 123.
- 29 For Algeria, see also Bourdieu (1966: 123-124); for Spain, see Pitt-Rivers (1966: 35).
- 30 Giovannini (1987: 68) writes of Sicily: 'Young women want to maintain the good reputation of their sisters, even at the risk of alienating them.' This is also an issue among Bedouins and Palestinians in Israel, as seen in Kressel's case study of Fatma Salim (1981: 151). After compromising her *namus*, Fatma Salim was murdered by her brothers-in-law. Their justification was that the reputation of their wives was at stake. The general view is that if one sister is no good, then all are no good. Pitt-Rivers (1966: 35): 'Social groups possess a collective honour in which their members participate: the dishonourable conduct of one reflects upon the honour of all, while a member shares in the honour of his group.' This con-signing of siblings to a single category also emerges in Brouwer (1992: 26), where a Turkish girl says: 'We were never addressed individually at home. Children are children, and what one does the others will do and think as well. I think that's what makes us different from a Dutch family.'
- 31 'Honour [is an] evaluatory term [...]. It validates itself by an appeal to the facts (on which it imposes its own interpretations)" (Pitt-Rivers 1966: 21). 'Since we are concerned with honour as reputation it is gossip rather than the truth that is relevant' (Pitt-Rivers 1966: 64). Peristiany (1966: 11) calls it 'the all-powerfulness of public opinion.'
- 32 Safilios-Rothschild (1969: 206) writes: 'A woman becomes dishonoured when she behaves like a man, enjoying freedom, especially sexual freedom.' A Turk would never formulate it in this way. In such a case, women are never said to be 'like a man'; instead, they

- are 'whores'. The word 'man' (*erkek*) is positive. If a woman is *erkek gibi* (like a man), this means that she is *sözü güvenilir* (reliable) and can cope in a difficult situation. This is how widows, who support their families alone, are described.
- 33 Pitt-Rivers 1966: 21 and 1968: 503.
- 34 Only illegitimate children have no *namus* (Black-Michaud 1975: 218).
- 35 'Şeref is social honor which one can earn and add to by behaving in accordance with societal norms.' (Magnarella 1982: 396).
- 36 Pitt-Rivers (1966: 53): 'Precedence [*şeref*] is something that can be gained through action – male enterprise, whereas shame [*namus*] cannot be gained and can only be maintained through avoiding the conduct that would destroy it – female restraint.' Black-Michaud (1975: 218): 'Whereas honour [*şeref*] is positive and cumulative, shame [*namus*] is negative, absolute (a woman either has it or does not – there are no degrees of shame) and cannot be increased.' Magnarella (1982: 396): 'A family cannot possess degrees of it (= *namus*); they are either *namuslu* (honorable) or not.' Ginat (1979: 153): 'The concept of 'ird (*namus*) is such that [...] it cannot be added to. By killing a woman, an individual does not gain honor, but restores it. Honor (*şeref*) can only be gained through actions committed by a man himself.' Ginat (1979: 182): 'A woman cannot by exemplary conduct add to her agnates' 'ird, though by misbehaving, she can detract from it.' Simmel (1908: 603): 'Und ist begreiflich, dass die Gesellschaft dem Einzelnen dies Gut [= Ehre] von vornherein mitgibt, so dass er es garnicht zu erwerben, sondern nur nicht zu verlieren braucht: die Präsumtion ist, dass jeder es besitze.'
- 37 Simmel 1908: 601-602; Pitt-Rivers 1968: 506; Bourdieu 1979: 125; Dundes 1986: 149.
- 38 See Blok 1981: 434-436 and Abu-Lughod 1986: 166.
- 39 Delaney 1987: 40; 1991: 39.
- 40 Gilmore (1987: 8): 'Explaining origins is a far cry from explaining trait persistence.'
- 41 Abu-Lughod (1986: 166-167): 'My concern with this ideology of honour is not so much with its causes or roots – a question much debated in the literature on circum-Mediterranean societies [...] and arguably unanswerable, given the complexity of human social life – but rather with its effects on individuals [...]. The system is reproduced by the actions of individuals motivated by a desire to embody the good.'

- 42 Bott (1957) speaks of a 'close-knit network'. The translation is from De Vries (1990: 22).
- 43 'Honour and shame are the constant preoccupations of individuals in small-scale, exclusive societies, where face-to-face personal, as opposed to anonymous relations are of paramount importance and where the social personality of the actor is as significant as his office' (Peristiany 1966: 11). 'Die Ehre verlieren, hiess die Zugehörigkeit zu seiner guten Gesellschaft verlieren. Man verlor sie durch den Richterspruch der gesellschaftlichen Meinung in diesen gewöhnlich ziemlich geschlossenen Zirkeln' (Elias 1969: 145).
- 44 "To quote Merry, these are: 'those in the middle of the social spectrum who are most concerned about gossip and most vulnerable to its consequences.' The least vulnerable are [...] those with contacts outside the local social system" (De Vries 1990: 23-24).
- 45 Wolf (1966: 81-82): 'The image underlying this terminology [many-stranded] is that of a cord, consisting [...] of many strands of fiber twisted together [...]. A manystranded coalition is built up through the interweaving of many ties, all of which imply one another: economic exchanges imply kinship or friendship or neighborliness [...].' The opposite is 'singlestranded'; 'Under these conditions [single-stranded relations] peasants are likely to find themselves in different social contexts, dealing with different individuals [...]. The result will be that many relations will be short-lived, with participants encountering each other only for brief moments.'
- 46 For their research neighbourhood in Winston Parva, where 'group charisma' (According to Blok [1980: note 53], the term honour would be more appropriate) is very important, Elias and Scotson note the following: "A local journalist, born and bred in 'the village', summed up his impressions of 'the village' [...]: 'You never know who is related to whom. There are so many family connections that I'm always discovering new ones, even though I have lived here all my life.'" (1965: 83) "Someone else said: 'There is so much intermarriage that you no longer know who is related to whom'" (1965: 83). "Not only neighbourhood links, but also family ties were clearly stronger in the research neighbourhood than in the rest of Winston Parva. These two relationships were closely interwoven [...]. The closeness of the family ties could not be maintained for long if neighbourhood relationships were looser or fell apart" (1965: 84).

- 47 “The families [...] were so closely interwoven that they became ‘open’ families, not separate in any respect. Activities within individual families and within networks of families overlapped with one another and could not be distinguished” (Elias and Scotson 1965: 95).
- 48 Elias (1969: 146): ‘In städtischen [...] Gesellschaften gibt es [...] für den einzelnen Ausweichmöglichkeiten, die der sozialen Kontrolle [...] viel von der Bedrohlichkeit und Verbindlichkeit nimmt, die sie in weniger mobilen landwirtschaftlichen Zirkeln [...] hat.’
- 49 “The more monolithic the jury, the more trenchant the judgement” (Peristiany 1966: 9). “A certain consensus must prevail about norms and values in the community [if these are to play a key role]; that community must be a moral community” (De Vries 1987: 23). “The effectiveness of social control depends to a significant degree on how securely anchored the rules of conduct are in the minds of the community. If they are not internalised, or are no longer present, then you should have no high expectations regarding adherence to the rules” (De Vries 1987: 36). “It is symptomatic of the high degree of control that a cohesive group can exert over its members that we did not hear of a single occasion during our research when someone broke through the group taboo on closer personal contacts with members of the ‘new’ group” (Elias and Scotson 1965: 75).
- 50 De Vries 1987: 11; Gilmore 1987: 94; Bott 1959: 67; Elias and Scotson 1965: 75.
- 51 “The impact of gossip and scandal is greater when it has the potential of producing a community consensus that can be converted into a variety of collective actions such as public shaming, ridicule, expulsion or death” (Merry, quoted in De Vries 1990: 14). “Gossip derives its effectiveness from the fact that it is so closely linked to [...] the negative sanctions that can follow from it. Not the gossip itself is feared, but what it may give rise to: becoming the subject of scandal, loss of reputation for oneself or one’s parents, being reprimanded or snubbed by compatriots, punishment at home” (De Vries 1990: 8). “I cannot comment on the extent to which certain community - sanctions such as ostracism are actually carried out, nor is it very important. Of greater importance is that people are afraid of such actions and that they allow this fear to dictate their behaviour” (De Vries 1990: 19).
- 52 “The standard anthropological treatments of honour and shame have dealt overwhelmingly with rural and/or preindustrial milieux.

- But can we be so certain of the incompatibility of honour and shame with urban industrial milieux? [...] We must repeat that research on honour and shame among residents of Milan, Athens, and Barcelona has yet to be carried out” (Brandes 1987: 126).
- 53 “The absence of a concern of honor and shame in Mediterranean cities reflects all too well the Redfieldian notion that urbanites are relatively free from the shackles of customary law; in the anonymous urban setting, Redfield believed, people develop individualistic behavioral codes and operate independent of public opinion. Under such circumstances, it would be impossible for a value system like that of honor and shame, which is based almost entirely on popular reputation, to exert its influence in cities” (Brandes 1987: 127).
- 54 Bott 1957: 65-66, 99.
- 55 This does not happen in tourist areas.
- 56 Balaman 1985: 212.
- 57 Delaney (1991: 101) and Petersen (1985) both refer to Bourdieu (1977: 44) to explain this: ‘Male honor is threatened by women. Specifically, a man’s honor is a function of the purity of the women in his family: his mother, his sister, his daughter. Since he cannot marry these women, it follows that the best, or least bad woman is the one who sprung from the men of the lineage, the patrilineal parallel cousin’. Bourdieu (1979: 127-128) also says: ‘The need to safeguard blood purity and keep the family honour intact is the reason most frequently given to justify marriage with the parallel cousin [...]. A man who married into his own family [...] can be sure that his wife will strive to safeguard her husband’s honour, that she will keep family conflicts secret and not run complaining to her kinsmen.’ It seems to me, however, that we should be cautious about making a comparison with Arabic culture because there a girl’s blood relatives retain responsibility for her *namus* even after her marriage.
- 58 In practice, marriage to the *amca kız* (the daughter of the father’s brother) is not more common than marriage to other cousins (Stirling 1965: 201; Delaney 1991: 101).
- 59 Delaney 1987: 44; 1991: 101-102 note 3.
- 60 According to Geçer (1995: 21), one in five marriages in Turkey is between blood relatives, and 80% of these are between first and second cousins. A 1993 study of marriages across Turkey revealed that, of the married women aged between 15 and 49, 22.6 percent married a relative (*Women in Turkey* 1999: 39).

- 61 A Turkish ethnic group from the Balıkesir region. They are seen as the 'true' inhabitants of Susurluk (Magnarella 1974: 34).
- 62 Not only Manav, but also gypsies, Circassians, Georgians and Bosnians in this region appear to support exogamy (Magnarella 1974: 90).
- 63 'Akraba evliliği yasaklansın', in: *Hürriyet* 24-II-1994.
- 64 In the Netherlands, work in this area is carried out by the VSOP (an association of parents' and patient organisations for hereditary and/or congenital defects) at Soestdijk.
- 65 Turks, originally from the Balkans, who now live throughout western Turkey (Sirman 1990: 35; Den Exter 1993: 33 note 6).
- 66 Sirman 1990: 35 and Sirman 1990: 35 note 21.
- 67 Asena 1987: 40-41.
- 68 Pitt-Rivers 1977: 83.
- 69 Burke 1992: 42.
- 70 See also Pitt-Rivers (1966: 25) on Western Europe in the Middle Ages: 'It was commonly admitted that offences to honour could only be redeemed through blood. La lessive de l'honneur ne se coule qu'au sang (the laundry of honour is only bleached with blood).'
- 71 Blok 1980, 1981.
- 72 For literature on blood revenge in the Balkans, see Black-Michaud (1975) and Boehm (1984). For blood revenge in Turkey, see Tezcan (1981) and Ünsal (1985, 1990).
- 73 Van der Molen (1983: 60).
- 74 The penalty for blood revenge is the death penalty: section 450/10 TCC (Şahin 1999: 35).
- 75 See Önder (1962: 427). The Criminal Code took effect in Turkey on 1 July 1926.
- 76 However, the Turkish Criminal Code does not use the term 'honour killing', which falls under *adam öldürme* (killing a person). Aykut (1999: 45): 'The use of the term honour killing suggests that there is a separate section of the law that deals with these murders. But this is not the case. There are only certain sections that provide for a reduced sentence in specific cases.'
- 77 Önder 1962: 569.
- 78 Şahin 1999: 39.
- 79 Tanrıyar 1987: 56.
- 80 Aykut (1999: 56-57) discusses this point specifically. Section 462 contains two conditions. Firstly, a time condition: the deed must have occurred during the adulterous or indecent situation, when it

was about to take place, or soon after it had taken place. Secondly, a personal condition: the victim must be the husband, the wife, the brother or sister, descendants and/or the person with whom the deed took place. Aykut (1999: 57) goes on to say that the tenor of this section is such that the person witnessing the deed receives such a psychological blow that he or she can no longer act of his or her own free will.

- 81 I wish to thank Muzaffer Cebesoy, a judge in Ankara, for his verbal explanation of these sections. The full text of these sections can be found in appendix III. With regard to ‘good behaviour in court’, it would be interesting to investigate whether this means or includes the kind of behaviour described in W. van Rossum 1998.
- 82 Its full title is *Cezaların Infazı hakkında Kanun* (The Implementation of Sentences Act), sometimes abbreviated as *Infaz Yasası* or *Infaz Kanunu* (Implementation Act). It is described in *Türk Ceza Kanunu* (2000: 437-462).
- 83 The *Infaz Yasası*, section 19 (*Türk Ceza Kanunu* 2000: 453) stipulates who should receive the death penalty, a thirty-year prison sentence, a life sentence, or a twenty-year prison sentence. The remaining sentences are reduced by half. In addition, the amended section 2 of the Implementation Act (*Türk Ceza Kanunu* 2000: 456) stipulates that a further six days be deducted from each month of the remaining half of the sentence to be served.
- 84 The relevant section (section 587 of the Criminal Code) was abolished in Italy on 5 August 1981. This was announced in the *Gazzetta Ufficiale* (the Italian Official Gazette), nr. 218, of 10 August 1981.
- 85 “For this reason, Greek journalists have been calling honour crimes ‘the camouflage of the criminals’” (Safilios-Rothschild 1969: 215). One example involves a man who killed his wife because she had been ‘unfaithful’. His true motive was that he wished to marry someone else, but divorce proceedings were very complicated and expensive (Safilios-Rothschild 1969: 214). This is also the theme of the 1961 Italian film, *Divorzio all’Italiana*, by Pietro Germi, and of the Sicilian novel, *A ciascuno il suo*, by Leonardo Sciascia, translated as ‘To each his own’ (Manchester 1989).
- 86 ‘20 yılı duyunca caydı’, in *Hürriyet*, 15-2-1997.
- 87 ‘Namus cinayetinde miras kavgası’, in *Hürriyet*, 28-5-1992.
- 88 ‘Hanım Ağa’ya infaz’ in *Hürriyet*, 21-1-1995; ‘Babalar dünyasında gerginlik. Eller tetikte’, in *Hürriyet*, 22-1-1995; ‘Olay çözüldü’, in *Hürriyet*, 23-1-1995.

- 89 Koran 24: 2 in Kramers.
- 90 See Koran 1992: note for sura 4: 15.
- 91 Juynboll 1930: 218.
- 92 Juynboll 1930: 298-306.
- 93 I wish to thank Léon Buskens for his help with this section. The relationship between Islam and honour killings requires further study. It would be interesting to discover which views, if any, the *Diyanet İşleri Başkanlığı* (Presidium on Religious Matters) in Turkey holds on this subject. Until now, we have only general information about the *Diyanet* (see Den Exter 1990).
- 94 Necati Haksun describes how the 15-year-old Feşo is buried up to her waist and a circle drawn around her at a distance of 10 paces. Many fist-sized stones are placed on the circle. After a *dua* (prayer) with the *hoca* (an Islamic cleric), the men of the village then stand on the circle and take turns throwing stones at Feşo. The husband throws the first stone, the father-in-law the second, the father the third. Stones continue to be thrown until Feşo is dead. The book was made into a film, entitled *Hazal*, which attracted considerable interest in Turkey at the time (Necatigil 1989: 154). The Turkish word for 'death by stoning' is *recm* (see also *Hürriyet*, 21-9-2000: 11).
- 95 Ginat (1979: 181) also reports an incident in which a woman who committed adultery was stoned (among Bedouins in Israel).
- 96 Durham 1928: 85.
- 97 'Ağabey'den infaz', in *Hürriyet* 17-6-1996. This honour killing occurred in the village of Fakılı Köyü (Arabian/Gaziantep). The article did not report who threw the stones, but I learned the details by chance. On Thursday 8 June 2000, I was watching the ten o'clock evening news on the Turkish broadcasting station NTV when the lawyer, Vildan Yirmibeşoğlu, was being interviewed following an honour killing in Istanbul. She referred to the killing in Fakılı Köyü, and said that the people in the neighbourhood (*mahalleliler*) had collected money to pay the police to release the girl. All the men in the neighbourhood then participated in the stoning.
- 98 It would be interesting to know whether Sunnites and Alawites differ with regard to honour killings. Wibo van Rossum once told me that he had heard that honour killing does not occur among Alawites. The Turkish public prosecutor in Ankara, Zekeriya Sevimli, denied this when I enquired about it. When working in Urfa, he encountered a case of a boy from an Alawite family who

- committed an honour killing. Further research into this aspect of honour killings has yet to be carried out.
- 99 Giovannini 1987: 70-71.
- 100 Vermeulen 1984: 28.
- 101 See Den Exter 1993: 18-22. His study shows a marked correspondence between a certain region of origin in Turkey and a town in the Netherlands.
- 102 Now that the second generation has reached adulthood, we see these links weakening. Sons are not allowed to smoke or drink in the presence of their fathers; this is seen as highly inappropriate behaviour. Either they go to a different coffeehouse, or the father does to spare his sons embarrassment.
- 103 I have taken this term from Böcker (1993: 59-60). It clearly demonstrates the composition of the Turkish community. It does not form a single whole; instead, there are different clusters, made up primarily of relatives or people from the same district. Within each cluster, people have a lot to do with one another. Turks living in the same Dutch city do not maintain indiscriminate contacts with all other Turks in that city.
- 104 'How many Turks receive unannounced visits from friends or relatives? All Turks. Do they send visitors away? Almost never [...]. They can stay up talking until the small hours. They talk about everything under the sun' (Alkan 1993: 131). The picture of the Turkish woman who sits alone at home while her husband is at the coffeehouse is far from accurate. Women visit one another in the evenings too. Children are not a problem; they simply go along as well.
- 105 De Vries 1987: 24.
- 106 Deug 1990: 186-187.
- 107 This applies primarily to women, who provide considerable support to one another in terms of childcare and companionship.

Notes to Chapter 2

- 1 This refers to both women and girls.
- 2 In discussions about honour killings, people often make exclusive reference to female victims, forgetting that there are male victims too. At a forum on honour killings and other forms of ritual killing, Sarıhan (1999: 59) claimed: 'Whether we are talking about a *namus* matter or a ritual, the victims of these types of murders are always

- women, even girls.’ Faraç (1998) also refers only to female victims. Ergil (1980b: 227), however, reveals that of the 273 honour killings he discusses, 73% of the victims were male and 27% female.
- 3 With a few exceptions; see 2.4, 2.5 and 2.6.
- 4 Ruggi (1998: 13): “The woman alone is punished for the ‘crime’; whereas the man, who may have raped his victim, is considered an innocent party and often walks free.” Kressel (1981: 152 point 22): ‘Girls are murdered even when they have fallen victim to rapists.’
- 5 Literally, ‘whose *namus* is defiled’.
- 6 Literally, ‘enemy of honour’.
- 7 See, for example, Delaney 1987: 36.
- 8 Kressel (1981: 141): ‘If the victim is a member of one’s own group, it is, by definition, murder and a terrible sin [...] or violation of a taboo [...]. Circumstances in which it is justified are rare and confined to cases occurring during the maintenance of law and in its name [...], or cases of mercy killing, euthanasia, and the like.’
- 9 “Murder of the gullible girl, daughter or sister, remains an internal matter and is therefore simpler to undertake” (Kressel 1981: 152 point 23).
- 10 ‘With the death of the deviant, spinster or adulteress, the group loses some of its potential fertility but gains a deterrent for others to see and fear’ (Kressel 1981: 144).
- 11 See Bovenkerk (1992: 143), who discusses the subject of crime victims being vilified and the scene of the crime being defiled. “The murderer swears at his victims, calling them ‘filthy whore’, or ‘despicable dog’, so that it is a blessing when these people are disposed of. It is also common for burglars to defecate in the room where they commit the offence. This symbolic defilement allows them moral leeway for committing their crime.” The honour violator can also be vilified. For instance, the girl’s family claims that he, or members of his family, have a criminal record.
- 12 Ruggi (1998: 12) gives the following definition of honour killing: ‘The execution of a female family member for perceived misuse of her sexuality.’
- 13 Kressel 1981: 143.
- 14 Kressel 1981: 147-151.
- 15 Kressel 1981: 152 point 24; Kressel 1981: 151 point 19.
- 16 Kressel 1981: 152 point 23.
- 17 Deug 1990: 165.
- 18 Tezcan 1981: 27.
- 19 Schiffauer 1986: 18.

- 20 Tezcan 1981: 26, 27.
- 21 Douglas 1966; Blok 1994: 34.
- 22 Lecture at the Willem Pompe Institute for Criminal Sciences, 21 October 1996.
- 23 In *Honneur et violence. Fatalité ou conjoncture pour les femmes Turques?* (Elele, 1998), the proceedings of a conference held in Paris in 1997, we find the discussion that followed the screening of the Danish documentary. Someone from the floor asked what had happened to Songül. Nukhet Sirman, a Turkish sociologist who worked on the documentary, said that Poul Martinsen, the Danish director of the film, had taken Songül to Denmark to rescue her as there was no future for her in Turkey. From the proceedings: “Yvon Charon: ‘A-t-on idée de ce qu’est devenue Songül?’ Nukhet Sirman: ‘[...] Songül a été sauvée par Poul Martinsen. Elle a été amenée de Turquie au Danemark où elle va à l’école; on lui a préparé une vie, à cause de ces mots là, car sa vie en Turquie est finie. Elle a eu la chance d’avoir une seconde vie grâce aux service sociaux danois.’” (1998: 162). Because I found this strange and in conflict with my own information, I telephoned Nukhet Sirman, who works at the Bosphorus University in Istanbul, on 2 November 1999, to ask her to explain the quotation from the conference proceedings. She said that her views had not been correctly recorded. What she meant was that Poul Martinsen, the Danish director, had set himself up as a ‘knight in shining armour’ who would take Songül to a better country. Martinsen did in fact take her to Denmark but Songül soon returned to her village. Nukhet told me that she had since heard that Songül was married to someone in her village. I said that I had the same information. Nukhet said that she could not abide Martinsen because of the way in which he had presented honour killings in his documentary. She felt that he had much too static a picture of *namus*, which was reflected in his attitude to Songül. She regretted that the documentary had been distributed on such a large scale. She had never taken the opportunity to write an article voicing her criticism.
- 24 This does not apply everywhere. It is possible that, in the Arabic world, killing the man who has violated a girl’s honour is not a means by which her *namus* or that of her family can be restored.
- 25 Cf. Van Eck 2000a.
- 26 It would seem that rape claims also occur among Bedouins, although they do not lead to the killing of the ‘rapist’. Kressel (1981: 149) reports in his ‘Fatma Salim’ case study that the girl’s family

- did not want to punish the girl. They pretended that she had been raped, so that she did not need to be killed.
- 27 Of twenty honour-killing cases, the woman was the victim in seven cases (Ardal, Biber, Dursun, Elmas, Gürsel, Türkmen, and Utlu), the man in twelve cases (Altuğ, Altun, Ayanoğlu, Barut, Çetin, Ercan, Köksal, Koparan, Şengül, Tekin, Uzun, and Yiğit), and in one case (Akkaya) both the man and the woman.
- 28 Rape claims also occur in the Uzun, Köksal, Şengül and Altuğ case studies.
- 29 An explanation as to why Fatih Çetin carried out the killing can be found in 3.2.
- 30 *Gayrimeşru bebek* (unofficial child) in Turkish. The popular term is *piç* (bastard), which is used as a term of abuse in Turkey. See 5.4.
- 31 See 1.3, Turkish jurisprudence and honour killing.
- 32 ‘Fethiye’de vahşet’, in *Hürriyet*, 20-11-1996.
- 33 ‘Tuvalette doğum’, in *Hürriyet*, 27-11-1996; ‘Bebeğini kesip foseptiğe attı’, in *Hürriyet* 28-4-1995; ‘İğrenç adam’, in *Hürriyet*, 12-8-1994.
- 34 ‘Gayrimeşru bebeklerini öldürdüler’, in *Hürriyet*, 19-2-1994.
- 35 ‘Hamile kızını öldürdü’ in *Hürriyet*, 15-12-1994.
- 36 ‘Sultanbeyli cinayetinde katil baba çıktı’, in *Hürriyet*, 14-4-1992.
- 37 Ginat (1979: 195) cites an example of a Bedouin woman in Israel who gave birth to an illegitimate daughter. The baby was not killed. Instead, the husband, who was not the baby’s father, decided to keep the child so that she could later carry out the heavy work around the house. Nor did he kill his wife, but sent her back to her parents.
- 38 ‘Baby Fatima had to die for family honour’, in *De Telegraaf*, 3 March 1990. The Turkish family did not give the baby a name; they did not want to know the baby’s sex. The baby was probably named by the hospital staff (Fatma, rather than Fatima, is a common name in Turkish).
- 39 Breteau 1980: 49.
- 40 ‘Sır kaçırmaya 2 infaz’, in *Hürriyet*, 16-2-1997. See 4.2 for the full case study.
- 41 ‘Kız kaçırma kavgasında 2 kişi öldü’, in *Hürriyet*, 12-8-1996.
- 42 Safilios-Rothschild 1969: 211. A child was an honour-killing victim in the multiple honour killings in 2.5.
- 43 This case study is based on Poul Martinsen’s 1988 Danish documentary, *Den sagtmodige morder* (The quiet killer).

- 44 He probably means an *imam* marriage as Fevzi is already married to Meryem (in the case of *imam* marriages, a man may be married to more than one woman simultaneously). Or he may have meant that Fevzi should divorce Meryem, and then marry Songül.
- 45 It is debatable whether Gülsüme was the guilty party. She may have given Meryem countless warnings. It probably suits Resul's purpose to accuse Gülsüme, thus assigning the blame outside his own family.
- 46 Lecture at the Willem Pompe Institute for Criminal Sciences, 21 October 1996.
- 47 'Aile katliamı', in *Hürriyet*, 21-10-1996. This article calls the multiple murder *namus katliamı*. Santing (1996) translates this term as 'a massacre for the sake of honour'.
- 48 Three months later, at the court hearing, the nine-year-old witness (Abdullah's daughter) changed her testimony, claiming that her father had acted alone (*Hürriyet*, 29-1-1997). Both brothers fled and various members of the family were taken into custody. This change may have been made under pressure from the family, to bring about the release of detained relatives.
- 49 This is not the general use of the word 'whore' (see 1.1), but refers to prostitution as a profession.
- 50 See also Santing 1996.
- 51 Examples can be found in *Hürriyet* 22-1-1995, *Hürriyet* 4-2-1995, *Hürriyet* 25-8-1995, *Hürriyet* 27-12-1995, *Hürriyet* 5-1-1996 and *Hürriyet* 21-2-1997.
- 52 Develioğlu (1993: 5).
- 53 'Kanlı cinnet', in *Hürriyet* 14-8-1995.
- 54 A religious marriage ceremony conducted by the *imam* (*imam nikâhı*). In Turkish village culture, this is the most important ceremony. The civil ceremony (*medeni nikâh*) is regarded as a mere formality.
- 55 For an explanation of 'horns', see 5.4.
- 56 'Töre infazında Fırat mucizesi', in *Hürriyet* 14-2-1998; 'Töre vahşetinde mucize kurtuluş', in *Hürriyet* 14-2-1998; 'Ailemi görmek istemiyorum', in *Hürriyet* 15-2-1998; 'O eve dönmem', in *Hürriyet* 15-2-1998; 'Canavarlar sorguda', in *Hürriyet* 16-2-1998; 'Tutuklandılar', in *Hürriyet* 18-2-1998; Faraç (1998: 81-98).
- 57 Faraç (1998: 82) claimed that she was 21 years old; the newspapers reported her age as 19.
- 58 Faraç 1998: 97.

- 59 Kressel (1981: 147) cites eleven instances in which the victims survived the honour killing attempt. In several cases, they then fell victim to a second, successful attempt.
- 60 Aykut (1999: 53-55) also describes the Gönül Aslan case, basing his account on that of Gönül's husband, Sakıp. Sakıp claimed he was still willing to reconcile with Gönül when they were standing by the river, but that she resisted and said to him: 'Are you a man? I've slept with Nihat.' For this reason, Aykut feels that the court acted rightly in judging that there had been 'serious provocation', because 'there would not be many people [read 'men'] in Turkish society who would let this insult go unpunished.' Faraç (1998: 96) shows, however, that this version of events is highly improbable.
- 61 'Namus meselesinden bombalı cinnet: 2 ölü' in *Hürriyet*, 11-5-1994.
- 62 'Babaya son bakış', in *Hürriyet*, 27-12-1991.
- 63 He was her *sözlü*, her 'betrothed'.
- 64 'Küçük bir yalan iki hayatı yaktı', in *Hürriyet* 11-1-1998.
- 65 Many Turks are insured with the Diyanet Vakfı, the Islamic Foundation in The Hague, for this very purpose.
- 66 The Dutch translation in the court records is a paraphrase of what was said. The records do not contain the Turkish version.
- 67 'Bir avukatın şok sözleri' (*Hürriyet* 7-4-1996); 'Bir cinayetin anatomisi. Sevda'yı Urfa öldürdü' (*Hürriyet* 7-4-1996), 'Üzülmediler' (*Hürriyet* 7-4-1996). Cf. Van Eck (1996: 24-25). Also described in Faraç (1998: 57-65). Mehmet Tamer is simply referred to as M.T. in the newspaper, but Faraç reports his full name.
- 68 Her family belongs to an *aşiret* (clan) (Faraç 1998: 59).
- 69 Mehmet Tamer and Sevda Gök are *teyze çocukları* (their mothers are sisters).
- 70 This is the standard translation, although tautological, as *sokak* means 'street'. This is analogous to translations such as 'the village of Yaycıabdal köyü' (*köy* is 'village'), and 'Süleymaniye meydanı square' (*meşdan* is 'square').
- 71 'Üzgünüm ama törelerimiz öldürmemi emrediyor.'
- 72 This is the maximum penalty for minors aged between 11 and 15 years. See note 21 in chapter 3.
- 73 'Cesedi beş gün morgda kaldı. Ailesi gelip almak bile istemedi' in Gülden Aydın, 'Bir avukatın şok sözleri' (*Hürriyet* 7-4-1996).
- 74 Faraç 1998: 60.
- 75 The reporter notes: 'Tam ayrılırken baş sağlığı dilediğimizde dede çok sinirleniyor. Sonradan öğreniyorum ki böyle "yüz karası"

- kızların ölümü, pisliğin temizlenmesiymiş. Baş sağlığı dilenmezmiş' ('When we were about to leave, we offered our condolences. The grandfather responded in a very irritated manner. We later learned that the death of a girl "with a black face" constituted the cleaning up of filth and that condolences are inappropriate.') in 'Üzülmediler' (*Hürriyet* 17-4-1996).
- 76 Faraç (1998: 25-36) describes the honour killing of the sixteen-year-old Hacer at Urfa in 1994. No gravestone was placed on her grave and no one visits the grave on religious holidays. In fact, her grave is impossible to find because it is overgrown with bushes.
- 77 In the Netherlands in the seventeenth century, those condemned to death were denied a 'decent' burial so as to make their punishment even harsher. (Blok 1995: 159-160).
- 78 'Töre davasında amcalara tahliye' in *Hürriyet* 2-12-1998.
- 79 Santing (1998). When I spoke to Zekeriya Sevimli, the Turkish public prosecutor in Ankara, on 19 July 2000, he was not surprised at the immediate release and did not understand what all the fuss was about. 'If the penalty is 4 years, 5 months and 20 days, in practice that means a prison sentence of about 2 years [since as a rule, under the Implementation of Sentences Act, prisoners serve about 40% of their sentence]. Therefore, the perpetrators have to spend a little over a year in prison. If there is no reason to assume that they will flee, those convicted are quite commonly released on the day of sentencing. They then sit out the rest of their sentence, especially if it is rather short, at a later date. It is therefore quite a normal procedure,' Sevimli assured me.
- 80 'Cinayeti "onay"a da lanet', in *Hürriyet*, 17-4-1996. See also Faraç (1998: 64). For photos from the *Hürriyet*, see Van Eck (1996).
- 81 Faraç 1998: 64.
- 82 Tanrıyar 1987: 56.
- 83 Şahin 1999: 38.
- 84 Zeynep Atikkan, 'Namus gerillaları' in *Hürriyet*, 18-4-1996.
- 85 Oral Çalışlar, 'Sıfır noktası. Namus katliamına yol açan kafa ...' in *Cumhuriyet*, 21-10-1996.
- 86 See Bas Mesters 1998.
- 87 It is interesting that Çalışlar should formulate it this way. Ibrahim Tatlıses, a well-known singer, puts it the other way round: 'A woman has what we call *namus*. A man does not.' Tatlıses and Çalışlar mean the same thing, however, as Tatlıses explains: 'I cannot explain it more clearly. A man goes to bed with someone, and is a womaniser [*zampara*]. The woman is a whore.' (Tanrıyar

- 1987: 55) In other words, a man may commit adultery and be admired for his sexual prowess and daring, while a woman in the same circumstances is condemned.
- 88 Şahin 1999: 67.
- 89 Sarıhan 1999: 68.
- 90 Şahin 199: 39; Sarıhan 199: 69; Töre cinayetleri 1999: 112-113.
- 91 Yirmibeşoğlu could be heard on the NTV evening news at ten o'clock on 8 June 2000. I have also spoken to her on the telephone.
- 92 Faraç 1998: 119.
- 93 Faraç 1998: 45-48.
- 94 Petersen 1985: 20.
- 95 Mernissi 1985: 21; Petersen 1985: 20. According to *imam* Ghazali, a man is obliged to satisfy his wife's sexual desires. Only then will a woman confine her attentions to her husband, thus preventing *fitna* (*fitne* in Turkish) from arising because she has seduced other men into illicit sexual relationships (Mernissi 1985: 21). *Fitna* is chaos, but also the fatal power of attraction that a woman has over men and to which they are forced to succumb (Mernissi 1985: 23).
- 96 This case study is described in 4.3.

Notes to Chapter 3

- 1 She was probably working on the side, otherwise she could not have received a benefit.
- 2 Blok 1994: 34.
- 3 See Blok (1995: 159) on the subject of the death penalty among the Goat riders: 'The sentences [...] were [...] not solely intended as the physical removal, visible to everyone, of the condemned persons from the village community. First of all, the removal had to be effected by means of a ritual in which something was said about the status of the condemned and the offences of which he was accused.'
- 4 This does not apply to the infanticide in 2.3. This took place in secret so that no one would know that the baby had ever lived.
- 5 In the court records of the 20 honour killing cases I discuss, gunshots are most common: a gun was used in 15 cases, a knife in three (Altun, Koparan, and Tekin), and strangulation in two (Biber and Ardal). The study by Van der Molen (1983: 59) also shows that guns are commonly used.

- 6 In the Sliedrecht honour killing, reported in Van der Molen (1983: 28), the parents wish to see the daughter whom their son has killed; they wanted her dead, and they worry that she has not actually been killed.
- 7 In the Gürsel and Türkmen case studies, the killers say that they regret not having had one final talk with the victim (their sister).
- 8 The standard formulation that these honour killers use, and which we encounter repeatedly in the *Hürriyet*, is *Namusumu temizledim. Pişman değilim* (I have purified my *namus*. I have no regrets).
- 9 Kressel 1981: 146.
- 10 Kressel 1981: 147.
- 11 An example of mutilation (to what extent is it symbolic?) in Turkey: 'A 33-year-old male and a 16-year-old girl attempted to run off together, but were caught by the girl's family [...]. The man's head, arms, and legs were cut off and his body was thrown into the Tigris River' (Magnarella 1982: 396).
- 12 Douglas 1966: 35.
- 13 Kressel (1981: 143) describes the following ritual among Arabic families in Israel at the beginning of the twentieth century: 'Prior to Western interference, purging the family honour was a public act. The elders of the Arab communities studied testify to the time (during Ottoman rule) when the murderer would sprinkle his victim's blood on his clothes and parade through the streets displaying the bloody murder weapon (usually an axe or knife) to increase his honour.'
- 14 In the Swedish television documentary about honour killings in Jordan, broadcast on Sunday evening, 23 May 1999, in *Netwerk* (Nederland 1).
- 15 Faraç 1998: 43-44.
- 16 In the Uzun case study, the perpetrator gives himself up the following day to the police. In the Koparan case study, the killer telephones the police as soon as he arrives home. In Ergil's study (1980b: 237), we see that in practice, many of the killers (64%) flee.
- 17 The child honour killers, Biber, Şengül, Elmas, and Uzun show no remorse. Nor do the honour killers Köksal, Türkmen, Altuğ, Barut and Ardal. The pathological honour killers Akkaya and Altun do show remorse, as do Koparan and Utlu (both unpremeditated honour killings) and Ayanoğlu, Yiğit, Tekin, Gürsel and Ercan. Dursun made no statement, and Çetin retracted his.
- 18 This was probably the case in the Ayanoğlu, Yiğit, Tekin, Gürsel and Ercan case studies.

- 19 'The act is premeditated, not a spontaneous reaction or an emotional expression' (Kressel 1981: 151 point 5).
- 20 '[...] a basic quality of ritual [is] that it is not an essentially spontaneous activity, but rather most, if not all of it is self-consciously 'acted' like a part in a play' (Moore and Myerhoff 1977: 7).
- 21 In Turkey, the penalty for minors aged between 11 and 15 years is usually reduced to half of the adult sentence, and may not exceed 7 years (section 54/2 TCK). For 15 to 18-year-olds, the sentence is usually reduced to two-thirds of the adult sentence, and may not exceed 14 years (section 55/3 TCK). The Implementation of Sentences Act is then applied, which reduces the sentence by about a further 60%.
- 22 More details can be found in 5.5.
- 23 In Van Eck 2000d, I discuss the issue of a possible accomplice who does not appear anywhere in the court records. There, I describe an honour killing that is not included in this study.
- 24 Ergil (1980b: 229) writes that the Turkish Criminal Code makes it easier for women to commit such an offence. If a woman kills her rapist/assailant on the spot to defend her *namus*, she can appeal to section 462, whereby her sentence is reduced to one eighth.
- 25 Ergil (1980a: 420) writes: '...lower class women kill when their honor is in their keeping, that is when their menfolk are away at the time and place of the crime, or when they are bachelors. Moreover there is a common expectation that Turkish women should show active resistance. For a woman stripped of her honor becomes a man which she shouldn't be. Only after her honor is restored does she revert back to her true sex.' I do not agree with the wording 'stripped of her honor'; a woman who is about to be assaulted or raped is not yet without *namus*; her *namus* is simply under threat. A better formulation would be: 'a woman who is about to lose her *namus*.' In addition, it is incorrect to include unmarried women in the list of those who should defend their own *namus*. Although an unmarried woman does not have a husband to defend her *namus*, she usually has a father and brothers who are expected to do so.
- 26 A further example would be Turkish widows who take on their husband's tasks. For example, officially asking for a girl's hand in marriage on behalf of a son. This is the job of the boy's father, but if he has died, his wife takes on this duty, as is expected of her.
- 27 The following are examples from the *Hürriyet*. Şevket Turşucuoğlu, who lived in Adana, killed the man who tried to assault his wife. His wife said: "*Kocam namusumu korumak için katil oldu*" (My hus-

- band became a murderer because he wanted to protect my *namus*) in: ‘Namusu için katil olan kocaya gözyaşı,’ *Hürriyet* 11-7-1992. Nejdet Özcan, who lived in the village of Gökgez köyü (Pamukova/Adapazarı), killed his friend Yaşar Bayrak because he attempted to rape Özcan’s wife. Özcan declared: “*Namusumu korudum. Yerimde kim olsa aynı şeyi yapardı*” (I have protected my *namus*. Anyone in my place would have done the same), in: ‘Namus cinayeti,’ (*Hürriyet* 24-2-1993).
- 28 Kressel 1981: 146.
- 29 Ergil (1980b: 229) writes that families allow a female family member to carry out the honour killing so that male members, who are ‘worth more’, do not have to go to prison.
- 30 Kressel 1981: 146.
- 31 ‘Tecavüzcüyü meydanda vurdu’, in *Hürriyet* 16-4-1996.
- 32 ‘Kızına tecavüz edeni öldürdü’, in *Hürriyet* 15-12-1995.
- 33 ‘Cinsel taciz katil etti’, in *Hürriyet* 16-2-1995.
- 34 ‘Namusumu temizledim’, in *Hürriyet* 12-12-1991.
- 35 ‘Narlıdere’de namus cinayeti’, in *Hürriyet* 20-9-1991.
- 36 Nesin 1978: 437.
- 37 I did not examine the court records for this case but obtained a summary of events from the local police.
- 38 Idil Kalkan also appears in the Altuğ case study, where she is the daughter of the honour-killing victim, Hacı Kalkan.
- 39 Van der Molen 1983: 27.
- 40 It would be interesting to investigate how honour killings from the 1960s (or even earlier) differ from 1990s killings. Safilios-Rotschild (1969: 206-207), who also poses this question, analysed articles on honour killings from Greek newspapers and observed the following changes: 1. there were more individual honour killings (not based on a group decision), 2. honour killings were only committed by close relatives (and not to cleanse the honour of a distant cousin), 3. more women were committing honour killings, 4. there were more honour killings following a divorce, which was unthinkable in earlier times. She cites as an example a husband who killed his ex-wife when she had a relationship with another man; he still regarded her as his possession. (Safilios-Rotschild 1969: 211-212).
- 41 Kressel 1981: 147.
- 42 In Gülden Aydın, ‘Bir cinayetin anatomisi’ (*Hürriyet* 7-4-1996). This case is also described in Faraç (1998: 39-53). Faraç (1998: 101-113) describes a further honour killing in the form of a tractor

accident: the 19-year-old Şemse Kaynak, from the village of Bakışlar köyü (Urfa), was raped by Salih Kaynak, the son of her mother's brother. She did not admit it until she was 4 months pregnant. Arrangements were made for Salih to marry her. However, her pregnancy was clearly visible at the six-month stage and the people of the Arabic *aşiret* (clan) began to gossip about her. Her brother asked Salih to take Şemse away but he refused. They twice went to a doctor for an abortion but the doctors refused to carry it out because the pregnancy was too far advanced. Finally, Salih denied that he had raped Şemse before the wedding. It was then decided that Şemse should be killed, and that it should be made to look like an accident. Her father, Halil, her older brother, Buğdat, and her younger brother, İbrahim, all drove the tractor. They claimed that Şemse had fallen from the tractor.

- 43 Faraç (1998: 41) writes: 'Although people in this region know what happens to girls who have run away, Rabia was cast into the arms of death.' According to the lawyer, Vildan Yirmibeşoğlu, the policeman had given her to her father after accepting bribes (see 2.10).
- 44 Faraç (1998) does not report the precise relationship.
- 45 Ginat, in response to Kressel (1981: 153), arrives at the same conclusion: "*Kressel uses 'solicited suicide' [...]. It seems to me that the crux of this type of killing lies in whether or not there is an attempt to evade justice. Thus, I would suggest the term 'pretended suicide' and would argue that it is a form of homicide in its own right.*"
- 46 Bovenkerk and Yeşilgöz (1998: 291). This is an example of an 'honour killing following a sexual insult' (see 5.4).
- 47 Kressel (1981: 147): 'secret burial can be interpreted as a preference for the non-involvement of the forces of law over giving publicity to the murder as required by tradition.'
- 48 The text says 'birth right', which cannot have been the intention.
- 49 For legal considerations regarding reduced sentences because of cultural background, see: Wormhoudt 1986, Van Rossum and Hoogendoorn 1997, Bovenkerk and Yeşilgöz 1999. See also Knoops (1998), who devotes an entire section to honour killings (p. 253-264).

Notes to Chapter 4

- 1 The most extreme example of arranged marriages is the *beşik kertmesi* (literally, 'carving the cradle'), whereby babies are prom-

- ised in marriage. See Gartmann 1981: 84, Balaman 1985: 210. Children may be consulted before the marriage is arranged, or the boy and girl may reach agreement themselves, but leave the official arrangements to their parents. In eastern Turkey in particular, marriages take place in which the girl has no say (Kardam 1999: 88). In 1993, only 25.9% of married women aged 15 to 49 years in Turkey claimed to have been primarily responsible for the decision to marry (Women in Turkey, 1999: 39).
- 2 Delaney (1991: 118) reports that the girl makes coffee for the guests. If she puts too little sugar in the coffee, this is a sign that she does not favour the marriage.
 - 3 Mansur 1972: 167; Gartmann 1981: 69; Schiffauer 1987: 16; Yerden 1995: 28.
 - 4 Schiffauer 1987: 31.
 - 5 Stirling 1965: 190; Sirman 1991: 47; Delaney 1991: 104.
 - 6 Nederlandse Jurisprudentie 1986/741: 2811-2814.
 - 7 The people they know best are the sons and daughters of aunts and uncles, which might explain why marriages between relatives are so common.
 - 8 Kressel 1981: 148 footnote 28; Van Nuenen 1997: 59.
 - 9 'It (*kız kaçırma*) [...] provides a way of evading the high costs of normal marriage.' (Stirling 1965: 193). Gartmann (1981: 76) cites the example of a woman who fled to her husband as a fifteen-year-old girl because his family could not afford to pay for a wedding. If it is only the boy's parents who favour such a step and allow their son to elope, they will not incur the expenses of a grand wedding but will have to pay the bride price, which is undoubtedly very steep, as compensation for the elopement (see later this section).
 - 10 'Another instance [to escape the rigidity of formal relationships] is provided by 'eloping' as a means for a young couple to escape an oppressive marriage project imposed by their elders (...). By allowing this kind of protest behaviour in prescribed and culturally accepted forms, the strains of the social system are, to a certain degree, mollified and consequently the overall structure is, if anything, strengthened. In such cases, one could argue that the institutionalised protest patterns have an integrative function' (Wertheim 1964: 28). See also Stirling 1965: 193; Mansur 1972: 166; Magnarella 1974: 113-117; Sirman 1990: 35 note 21.
 - 11 Magnarella 1974: 116.

- 12 Magnarella 1974: 118; Kudat 1974: 292; Meeker 1976: 415; Balaman 1982: 55.
- 13 Kudat (1974: 292), Magnarella (1974: 120), Schiffauer (1987: 206), Meeker (1976: 414), Yalçın-Heckmann (1991: 255), Van Nuenen (1996: 70).
- 14 Cf. Bates 1974: 275; Kudat 1974: 291.
- 15 ‘Sır kaçırmaya 2 infaz’ in *Hürriyet* 16-2-1997; ‘Ölümü göze alıp kaçtılar’ and ‘Aşk kana bulandı’ in *Hürriyet* 17-2-1997; ‘Ülkü polise sığındı’ in *Hürriyet* 21-2-1997; ‘Ülkü: Cesedimi çuval içinde göndereceklerdi’ in *Hürriyet* 25-2-1997; ‘Kendisi kaçtı’ in *Hürriyet* 27-2-1997.
- 16 ‘Elif’i kurtarana 10 bin mark ödül’ in *Hürriyet* 28-8-1994; ‘Kaçırılan Elif’e nikâh baskısı!’ in *Hürriyet* 29-8-1994; ‘Elif, hâlâ sır’ in *Hürriyet* 30-8-1994; ‘Elif için ihbar yağmuru’ in *Hürriyet* 31-8-1994; ‘Kaçırılan Elif evli dönüyor’ in *Hürriyet* 2-9-1994; ‘Bizimki yıldırım aşk’ in *Hürriyet* 3-9-1994; ‘Kaçırılan Elif Almanya’da farklı konuştu’ and ‘Elif: isteyerek nikâhlanmadım’ in *Hürriyet* 4-9-1994; ‘Elif Cihan, Trabzon’da başına gelen olayları anlatıyor. Bir dağa kaldırma hikâyesi’ in *Hürriyet* 13-9-1994; ‘Ve, Elif boşanıyor’ in *Hürriyet* 4-10-1994.
- 17 ‘Elif Cihan, Trabzon’da başına gelen olayları anlatıyor’, in *Hürriyet* 13-9-1994.
- 18 Van Veen 1989.
- 19 Joris 1981: 52; Nellestein 1981: 51-54.
- 20 Joris 1981: 30.
- 21 Nellestein 1981: 54.
- 22 Delaney 1991: 109-110.
- 23 ‘Abducted Turkish girl rescued following rape’ in *de Volkskrant* 12-5-1997; ‘Turkish girl fabricated Rotterdam abduction’, in *de Volkskrant* 13-5-1997.
- 24 Joris 1981: 30.
- 25 Nellestein 1981: 55-56.
- 26 Yerden 1995: 35.
- 27 Van Nuenen 1995: 5.
- 28 Mansur 1972: 167; Magnarella 1974: 113; Santing 1987: 31.
- 29 Stirling 1965: 194; Bates 1974: 275. Meeker (1976: 415) treats the *şeref* of Turkish fathers very lightly. He claims that, following an elopement, the father’s *şeref* is always restored by means of the bride-price paid to him. According to Meeker, this sum need not be particularly high.
- 30 Delaney 1991: 119.

- 31 The widely-held belief that elopements are undertaken to evade the bride-price (Özgen 1985: 323) is generally incorrect. Nor is there any statistical support for this view. Most elopements occur in western Turkey, whereas most bride-price payments are made in eastern Turkey (Özgen 1985: 347).
- 32 Van Nuenen 1996: 30, 33.
- 33 Mansur 1972: 167; Gartmann 1981: 75.
- 34 'To avenge their sexual honour [...] through legal action only aggravates the dishonour by publicising it.' (Pitt-Rivers 1966: 67)
- 35 The boy's father may also oppose the elopement, although judging by articles on elopements in the *Hürriyet*, this is far less common. I know of one example in the Netherlands of a Turkish father who opposed the marriage of his son to a Dutch girl and disowned his son. The boy was no longer welcome in the homes of his family.
- 36 It is not customary for weddings to take place during Ramadan (*Ramazán* in Turkish). The reference here is to the *imam* ceremony, which is regarded as the 'real wedding'.
- 37 Durham 1928: 85.
- 38 Kressel 1981: 147. Further research is needed to find out whether these views are common amongst Turks as well.
- 39 'Çifte infaz', in *Hürriyet* 29-1-2001.

Notes to Chapter 5

- 1 See Van Eck 1997b.
- 2 Honour killing is meant here, not blood revenge.
- 3 Makal has only celebrated the *imam* ceremony with Emel (under certain conditions, Islam allows a man to have more than one wife; the maximum is four). Because an *imam* ceremony alone is an insufficient basis for bringing a spouse to the Netherlands, Makal replaced the photo in his first wife's passport with a photo of his second wife and brought her to the Netherlands on the false passport. Officially, his second wife bears his first wife's name. This was initially a source of much confusion during the police investigation.
- 4 The court records contain newspaper clippings. For reasons of anonymity, I have not named the local paper.
- 5 Cf. Van Eck 1998a and Van Eck 1998b. I would like to thank police officer, Frank Kornaat, for obtaining this case study. Because the perpetrator in this case was born in the Netherlands, the honour

- killing was not registered at the Central Judicial Archives in Almelo (see Introduction, note 13).
- 6 Presumably, he means an *imam* marriage initially, as the civil marriage to Mustafa has not been annulled.
- 7 Mustafa and Ebru had already married in a civil ceremony, but because the *imam* ceremony had not yet taken place, he was still referred to as her fiancé.
- 8 Yeşilgöz also mentions the term *ağır sözler* (literally: heavy word). Ergil (1980b: 220) gives the more judicial term *sözlü hakaret* (literally: verbal insult).
- 9 Nauta (1991: 31-34) cites a large number of sexual insults.
- 10 Blok (1981: 220).
- 11 See also Schiffauer (1986: 37): ‘Mit grosser Zurückhaltung wird schliesslich alles erörtert, was die Ehre eines anderen Mannes beflecken könnte [...]. Das Wissen um die Gefährlichkeit des Wortes ist der Grund für diese Vorsicht.’
- 12 The difference is that Iago, Othello’s ensign, suggests these clues to him. In the case of pathological honour killers, their suspicions are imagined.
- 13 Enoch (1980: 30).
- 14 Yeşilgöz 1995: 87-90. Perhaps this is because he bases his account on reports from the Pieter Baan Centre for Forensic Psychiatry, which concentrated solely on the perpetrator.
- 15 Enoch (1980: 30).
- 16 Enoch (1980: 30).
- 17 Enoch 1980: 32).
- 18 Enoch (1980: 32).
- 19 Enoch (1980: 34).
- 20 Anonymous (1989: 77).
- 21 Kezban was murdered at Zwijndrecht in 1999.
- 22 The Turkish text of this quotation reads as follows: “*Hey avratlar, Cennet kocalarınızın ayakları altındadır. Mânası neymiş biliyon mu? Yani bir kadının kocası ne dek kötü olursa olsun, kadın baş kaldırmıyacakmış kocasına. Hemi de her dediğini kusursuz yapacakmış kocasının, dediydi*” (N. Haksun, *Meyro* 12).
- 23 Ergil (1980b: 197).
- 24 On this point, see also Matlé (1998: 9), in which the Turkish father says to his daughters: ‘Youth clubs, women’s centres, male friends, whoredom; that’s the path rebellious girls take to their ruin.’
- 25 The job of *kapıcı* (concierge) is often carried out by a family who lives in the basement of the block of flats where they work.

- 26 'Eşini öldürdü, intihar etti', in *Hürriyet*, 4-7-1994.
- 27 'Gurbetçi cinneti', in: *Hürriyet* 10-8-1996; 'KARISINI vurdu, intihar etti', in *Hürriyet* 13-9-1995; 'KARISINA kızdı canına kıydı', in *Hürriyet* 5-1-1995.
- 28 'Baba dehşet saçtı', in *Hürriyet* 21-11-1993.
- 29 Ergil (1980a: 422).
- 30 Ergil (1980b: 233) also mentions this point. The men involved have lost some of their status, they are 'older' (69% are over thirty) and their wives treat them without respect. Almost all police reports present the same picture: an argument about a trivial matter escalates into the killing of the partner, followed by suicide. The case study of the *albay* (see Introduction, note 8) is one such example: the colonel commits suicide after killing his wife. In another example from Ergil (1980b: 234), a woman calls her husband *yaşlı budala* (old fool), whereupon he shoots her and then himself.
- 31 In 'KARISINI vurdu, intihar etti', in *Hürriyet* 13-9-1995.
- 32 In 'KARISINA kızdı canına kıydı', in *Hürriyet* 5-1-1995.

Notes to Chapter 6

- 1 The *Hürriyet* reports an honour-killing six times a month on average (see Introduction).
- 2 Other researchers are of the same view. Hermet (1997: 50): 'Le plus souvent, des alternatives sont trouvées pour le rétablir.' Emanuel Marx (1981: 155): 'Everywhere in the Mediterranean, and elsewhere, women become involved in premarital or extramarital affairs. Many of these affairs are settled quietly and without fuss, but many become public knowledge. Even among these latter, only a small proportion ends in a killing.' Ginat (1979: 182): 'There is one general feature – whenever there is a possibility of hiding shame [...], the woman is not punished.'
- 3 'The ultimate vindication of honour lies in physical violence and when other means fail, the obligation exists [...] to revert to it' (Pitt-Rivers 1966: 29).
- 4 See the Bitlis case studies (appendix II).
- 5 The Turkish text of this quotation reads as follows: '*Namus ölçüsünün bu denli kesin olduğu toplumumuzda başı dik gezebilmek namus değerlerine uymakla mümkün oluyor [...]. Bu nedenle toplumda ahlaksızlık fazla görülmez herkes bu ölçüyü korumaya azami dikkat gösterir.*'

- 6 There is a further reason for honour issues not arising: the girl commits suicide instead of fighting for the man she loves. In the first half of 2000, 28 girls committed suicide in Muş Province in southeastern Turkey after marriage arrangements they did not agree with (Aldoğan 2000: 19). ‘If there are this many in Muş Province alone, then what is the total number of girls who resort to this option?’ asks the journalist.
- 7 Hermet 1997: 50.
- 8 Even if the man has heard the gossip, he may be willing to marry the girl. Boehm (1984: 71), who conducted research among the Montenegrins in the Balkans, writes: “Sometimes a girl of tarnished reputation might manage to marry a man from a distant tribe [...]. In his own tribe, there would be some talk of her bad reputation ‘back where she came from’, but people would judge him less harshly than if he were to marry a woman of dubious moral reputation from his own tribe, whose conduct would have been well discussed in the local gossip mills.”
- 9 Deug 1990: 165, 179. We encounter an example of a forced marriage following a rape in Necati Haksun’s story, ‘Meyro’. The story of the girl, Şemse Kaynak (Faraç 1998: 101-113), is a further example (see note 42, chapter 3).
- 10 Safilios-Rothschild 1969: 213, 214.
- 11 Abbrin 2000, Muijen 1990: 30-39, Matlé 1996: 104-121, Canatan 1995. This last report reveals that boys too are sent to Turkey, usually for a Turkish education. However, almost two-thirds of the children sent back are girls (Canatan 1995: 8, 11).
- 12 Canatan 1995: 12.
- 13 Austin 1998: 40.
- 14 Deug 1990: 75.
- 15 Meeker 1976: 416.
- 16 Meeker 1976: 383.
- 17 Yeşilgöz and Coenen 1992: 29.
- 18 Arıkan 1996: 21.
- 19 I am not referring here to the Islamic legal term.
- 20 A son may also be disowned (see note 35, chapter 4). In a letter to his son, the father in the Biber case study threatened to disown him if he refused to carry out the honour killing.
- 21 Schiffauer 1987: 196, 206.
- 22 This happened in the Netherlands too: “In about 1960 an unmarried mother was still a scandal for her family, a sinner. [...]. Mother and child were often disowned and had to rely on charity [...]. Truus

- Nieuwendijk (75), a social worker at the time [...]: ‘After three months you had to check up on mothers who had to manage on their own with their child. It was often women whose families had disowned them.’” in: Jungschleger 1997.
- 23 ‘Kızım artık ailede lanetli’, in *Hürriyet*, 15-2-1998.
- 24 It is interesting that Sedat uses the term *şeref* for a woman (see 1.1). The word *şeref* has been left untranslated in the court records, which is how we know that it was used.
- 25 Greek folklore and literature tell of a dishonoured girl committing suicide out of shame (Safilios-Rothschild 1969: 206 note 8).
- 26 ‘Babanın dramı’, in *Hürriyet*, 6-12-1997.
- 27 Gilsenan 1976: 205.
- 28 Deug 1990: 51, 180.
- 29 Van Soest 1991: 48.
- 30 Petersen 1985: 37.
- 31 ‘Individuals interpret the notion [of honour] very much as they please and as circumstances permit, manipulating it in furtherance of their own political ends’ (Black-Michaud 1975: 179). He is writing here of *şeref*. But he says the same of *namus*: ‘Shame, like honour, is a [...] subjective goal of conflict; and like honour, its very subjectivity makes possible a number of inconsistent and mutually contradictory interpretations. Thus, what constitutes and what does not constitute shameless behaviour on the part of a woman depends to a very large extent upon the political status of her agnatic group, the influence and military strength of her husband and his group, and the current of popular opinion at a given moment’ (Black-Michaud 1975: 227).
- 32 Pitt-Rivers 1966: 28.
- 33 Schiffauer 1986: 17.
- 34 Starr (1978: 196) gives the example of a commander who wants to go to bed with Adnan’s wife. Adnan immediately acts to prevent this. ‘Had Adnan not acted quickly to limit the commander’s access to his wife, Adnan might have been rendered powerless to do so later. The amount of power the commander can muster, and his extensive networks to other persons in authority, provide him with far more credibility, and hence ability to force his interpretation of events than Adnan has.’
- 35 Gilsenan 1976: 201.
- 36 Black-Michaud (1975: 182) writes: ‘It is this kind of calculation which determines the manner in which individuals or groups will envisage their obligation to act honourably.’

- 37 Blok 1974: 237-238: point 15.
- 38 Starr 1978: 174.
- 39 Black-Michaud (1975: 70) terms this 'peace-in-the-feud.' Black-Michaud (1975: 66) also mentions the Turkish concept of *küs*, and cites Stirling (1965: 248).
- 40 Starr 1978: 174.
- 41 Schiffauer 1983: 68.
- 42 Kressel 1981: 143 note 12.
- 43 Breteau 1980: 51.
- 44 Van der Molen mentions this explicitly as an alternative to honour killing: 'According to honour killers after the event, a sincere apology for sexual insults, in the presence of others, would often have sufficed.' (Van der Molen 1981: 51) 'In the police files investigated, there are several instances in which honour killers commented that an apology would have prevented them from going ahead with the honour killing' (Van der Molen 1981: 69).
- 45 Deug 1990: 180.
- 46 Gilsenan 1976: 202.
- 47 See also Abrahams 1994: 64.
- 48 'Threatening behaviour from male members of the family can be a means of satisfying the expectations of the outside world and is an expression of their absolute disapproval' (Deug 1990: 165-166). 'A girl said that her mother's family bought a weapon to avenge her [because of incest]. She did not mind because she thought they would probably not use it' (Deug 1990: 166).
- 49 Henk Driessen points out that, in addition to 'honour' (in the sense of *şeref*), the Arabic word *nif* means 'nose'. Noses are seen as an important symbol of honour.
- 50 'Kocası burnunu kesti', in *Hürriyet*, 14-3-1996.
- 51 Durham 1928: 85.
- 52 Section 11 reads: 'If the woman or girl is willing and runs away from her house [elopes], her vulva shall be branded' (Heyd 1973: 98).
- 53 'Hayat kadınının saçını kazıdılar', in *Hürriyet*, 28-4-1996.
- 54 Delaney 1991: 130.
- 55 Kressel 1981: 148.
- 56 'Çapkın gencin kulağ kesildi', in *Hürriyet*, 24-2-1996.
- 57 Bourdieu 1979: 117 and 118.
- 58 Van der Molen 1981: 69.
- 59 Durham 1928: 84.
- 60 Ginat 1979: 191-192 case study V.
- 61 Ginat 1979: 186.

- 62 Durham 1928: 79.
- 63 'The hiding of a lover after a husband discovers his wife's adultery is a technique used to cool emotions in such situations' (Starr 1978: 211).
- 64 Bourdieu 1977: 118.
- 65 Pitt-Rivers 1966: 30.
- 66 Schiffauer 1983: 69.
- 67 Tanrıyar 1987: 53.
- 68 In the Netherlands, section 241 of the Criminal Code lapsed in 1971; under this section, adultery, following a complaint, was punishable by a six-month prison sentence, provided the complaint was followed by a petition for divorce or separation.
- 69 Tanrıyar 1987: 56.
- 70 *Zina* (adultery, immorality) on the part of a man was punishable until 1996 (section 441 TCK), and *zina* on the part of a woman until 1999 (section 440 TCK). See also 'Adultery with impunity in Turkey', in *NRC Handelsblad* 25-6-1998.
- 71 The maximum penalty for abduction is 10 years imprisonment. The minimum penalties are as follows: abduction of an unmarried woman, a 3-year prison sentence; abduction of a minor, 5 years; and abduction of a married woman, 7 years. Thus, according to the Turkish Criminal Code, it is a worse offence to abduct a married woman than a minor (Özgen 1985: 330 and sections 429-430 TCK). The probable rationale behind this is that the solution [honour cleansing] is more straightforward for an unmarried girl – namely marriage to either the abductor or to another man – but this is no longer a possibility for a married woman. Turkish judicial literature can be found in S Bakıcı, *Açıklamalı içtihatlı genel adap ve aile düzenine karşı cürümler*. Ankara: Adalet Yayınevi 1994, and Selçuk, S, *Kızlık bozma suçu. Öğreti-İçtihat*. Ankara: Adil yayınevi 1996.
- 72 'Çılgın aşıklar yatakta basıldı', in *Hürriyet* 26-9-1994.
- 73 Durham 1928: 84.
- 74 Breteau (1980: 51) also mentions the enlisting of prominent figures for negotiation purposes.
- 75 Kressel 1981: 143 and endnote 11.
- 76 Television programme 'Sıcağı sıcağına' on the 'ShowTV' channel, on 15 January 1997. The incident occurred in Urfa.
- 77 One section of the Turkish Criminal Code stipulates that this form of abandonment should be punished less severely when *namus* is involved. Abandoning a child (0-12 years) is subject to a prison sentence ranging from 3 months to 30 years (section 473). Section 475

stipulates, however: 'If a baby born out of wedlock is abandoned when less than five days old, and this is done to save the *namus* of oneself, one's wife, one's mother or child or sister, the sentence shall be reduced by between one sixth to a third.'

- 78 'Bebeğini istemedi', in *Hürriyet* 23-2-1996.
79 'Tecavüz utancı', in *Hürriyet* 7-9-1995.
80 'Sokaktaki bebek', in *Hürriyet* 26-8-1995.
81 'Bebeğini terk eden Türk kadın beraat etti', in *Hürriyet* 16-9-2000.
82 'Tecavüzcüye pusu', in *Hürriyet* 30-8-1995.
83 In another example from the *Hürriyet*, the boy, Mehmet İşler, runs off with a girl from the Dağ family. In return, the girl's brother elopes with (or abducts) Mehmet İşler's sister. The *mahalle muhtarı* (neighbourhood leader) acts as an intermediary and two marriages result ('Kızkardeşlerini kaçırdılar', in *Hürriyet* 14-3-1996).

Notes to Chapter 7

- 1 Gosewehr and Verheijden 1983: 8.
2 Ginat (1981: 153) writes on this point: 'It is difficult to assemble statistics regarding women who were not killed even though they had had illicit sexual relations [either adultery or premarital sex] and this fact was public knowledge. Those who have conducted field studies know that there are many more cases of this latter kind. This fact must be incorporated in any discussion regarding homicide and family honor.' Boehm (1984: 94) gives a similar warning with regard to blood feud: 'Foreigners reporting on how Montenegrin feuds started tended to look at the overt causes of feuds as being highly trivial [e.g., Durham 1928], emphasizing that the initial killing might have come from a sheep's merely straying from the pasture of one tribe onto that of another, or some such minor incident [...]. These foreigners missed the point that every year literally thousands of other straying sheep caused disputes that did not have any homicidal consequences.'
3 Malinowski (1926: 9-11) asked: 'Is there not, with regard to some rules at least, a binding mechanism, backed up by real motives, interests and complex sentiments?'
4 Sherry Ortner 1984. Van Os 1997: III-III2. Ginat (1979: 200) also makes this point with regard to honour killing: 'Ideology does not rule supreme and reality creates its own patterns which are often variations of ideology, modifications and compromise solutions.'

- There is no one pattern of conduct in spite of the general condemnation of unlawful relations.'
- 5 'Mutilating the context by omitting key ethnographic information, details about the facts and circumstances of the [violent] crimes cannot help but lead to a lack of perception and understanding' (Blok 1994: 29).
- 6 Ginat 1979: 183.
- 7 'It must be established when it is that deviant sexual behavior is punished by death and when treated with leniency' (Ginat 1981: 153) and: 'The aim of this study is to establish when, in the society under consideration [Arabs in Israel], deviant sexual behavior is punished by death, what sanctions are used and when such conduct meets with leniency' (Ginat 1979: 182).
- 8 'The almost total lack of uniformity which characterizes reactions in numerous cases, in which an apparently similar point of honour is at stake, bears witness to the flexibility of a notion which defies summary in terms of a limited number of well attested ethnographic facts.' (Black-Michaud 1975: 179)
- 9 Kressel 1981: 151. Black-Michaud (1975: 227) also sees this as a criterion: 'the current of public opinion at a given moment.'
- 10 'The decision to put a death sentence into effect against a son/daughter depends on whether his/her degrading act is publicised and to what extent. It is not a matter of punishment to fit the crime' (Kressel 1981: 151 point 18).
- 11 Pitt-Rivers 1966: 27.
- 12 Deug 1990: 51.
- 13 Pitt-Rivers 1968: 509 and 1966: 26. See also Pitt-Rivers 1968: 505: 'Whatever occurs in a person's presence obliges him to react in one way or another, positively or negatively, for he cannot hide his cognizance of it: he is inescapably a party to what he witnesses, and his will is thereby committed. This is important because the essence of the social person comprises his will and [...] his intentions. Hence, apologies for an affront normally take the form of denying the intention ['I didn't mean it like that'], thereby making the affront in a sense fortuitous because not willed. The true affront to honor must be intended as such.'
- 14 Durham 1928: 85.
- 15 See section 462 of the Turkish Criminal Code. A direct confrontation relating to 'blood feud' is cited as an example by Gilsenan (1979: note 25). Mr. X is supposed to commit blood feud but doesn't really feel like it. When Mr. X is walking in the street with a dis-

tant acquaintance, the latter points to an old man walking in front of them and says: 'Hey, that's the man who killed your father's uncle forty years ago.' X pulled out his pistol and killed the old man. Gilsenan writes: 'The point is that he forced a definition of the situation on X who had to recognize that his total social identity was at issue.'

- 16 Ginat 1979: 200.
- 17 Ginat in Kressel 1981: 153.
- 18 See 6.2, 'Behaving as though nothing has happened.' The citation from Petersen (1985: 37) referred to there is equally relevant here.
- 19 Ginat 1979: 183.
- 20 'Deficiency [in honour] opens the way to social destitution' (Peristiany 1966: 10). 'The deceived husband cannot [...] easily show up in the public domains dominated by competitive men' (Blok 1981: 432). See also Gilsenan (1976: 200): 'The individual is socially compromised, devalued in some degree, or even, in extreme circumstances, destroyed as a moral and social being.'
- 21 We have to be wary of information contained in the written summary of argument submitted by the counsel for the defence, whose function is not to provide 'objective information', but to present the facts to the best advantage of the client.
- 22 In this respect, honour killing is similar to blood feud. 'Tant que la vengeance n'a pas eu lieu, on porte, d'une façon ou d'une autre, le deuil, et l'on vit dans la honte. Par la vengeance, le groupe retrouve la vie: elle est saluée par une véritable fête' (Breteau 1980: 49).
- 23 'En korkulan mahkum müebbet hükümlü', in *Hurriyet* 28-6-2000.
- 24 Ginat 1979: 182.
- 25 This is a reference to pollution (see 3.2). Ibrahim was seen as *kirlenmiş* (dirty, soiled), because his mother behaved dishonourably. Kressel (1981: 149) reports another case of spitting in the context of loss of *namus*. A dishonourable girl was buried on a bare hill, and whenever members of her family passed by, they would spit in her direction.
- 26 With regard to honour killings that take place in southeastern Turkey, the killers and their families are often members of a clan (*aşiret*). Though frequently living as a family in the cities, they retain strong links to their clan. Older clan members may insist on an honour killing. Examples are the honour killing cases 'Knifing in the square' (2.9, see Faraç 1998: 57-65), where the clan members are Kurds, 'Thrown into the Euphrates' (2.8, see Faraç 1998: 81-98) and 'Şemse Kaynak' (3.6, see Faraç 1998: 101-113). In the latter case

- study, the clan is of Arabic origin (*Arab kökenli*), which in this case means that Arabic is their mother tongue and that they originally came from Syria or Iraq.
- 27 There are exceptions: people continue to frequent the man's business if he earns his living in the local community and has a clear monopoly, thus making him indispensable. An example can be found in Starr (1978: 40, 154, 161, 207), where Adnan, the only baker in the village, manages to keep afloat financially despite the fact that his wife is having an affair.
- 28 De Vries 1993: 35.
- 29 Ginat 1979: 193-194: 'The rabbi's action must [...] be seen in its political and economic context [...]. His status in the community together with his political influence on the local plain had been threatened, as well as his continuation in office. This would have economic consequences. Although he claimed to have acted to preserve morality, he did not act before his position in the village was seriously jeopardized.'
- 30 The word 'donkey foal' (*sıpa*) is used instead of 'child', for the sake of alliteration.
- 31 Case study III (Ginat 1979: 188-189): A young man who lives near the Syrian-Lebanese border runs a business with his brother-in-law, with whom his married sister is having an affair. The young man does not favour an honour killing, but a paternal uncle urges him to do it because he wants his nephew to return to his agnates rather than forge close links with his wife's family. The young man breaks off the partnership with his brother-in-law and kills his half-sister. Case study IV (Ginat 1979: 189-191): An unmarried Bedouin girl becomes pregnant by a Bedouin boy from another clan. The girl's uncle accuses the father of doing nothing and insists on an honour killing. He has political motives for doing so. He wants to use the deliberations about the honour killing to reunite the *Khams* (a group of descendants down to the fifth generation who are united by collective responsibility). The head of the *Khams* had died a few years earlier and since that time the *Khams* has been fragmented. The uncle hopes that the question of honour will reunite the *Khams*, with himself at the head. The girl is eventually found dead in a well.
- 32 Ginat 1981: 153: 'My understanding is that the accuser (i.e. the one who accuses the father or brother of a girl of misbehaving and incites them to kill her) uses values as an excuse. Field research

- more often than not indicates that economic and political reasons underlie any accusation made at the value level.’
- 33 Ginat (1979: 198). The use of a question of honour as a pretext, followed by an honour killing, is also the theme of the Italian film *Divorzio all’Italiana* and the book (and film) *A ciascuno il suo*. See note 85, chapter 1.
- 34 Kressel 1981: 151 point 19 and Kressel 1981: 150.
- 35 See also Yeşilgöz 1992: 29-30.
- 36 Delaney 1987: 86.
- 37 We see this in the Köksal case study: Hikmet insisted on an abortion when he heard that Ebru was pregnant by him when married to someone else.
- 38 For a woman’s *şeref*, see 1.1.
- 39 Sometimes a boyfriend does not accept the fact that a girl, who does not have a new boyfriend, wishes to end their relationship. Safilios-Rothschild (1969: 211 note 24) writes that Greek girls wishing to terminate a relationship invent the pretext of illness so that the boyfriend will end it. ‘Greek girls have devised a useful routine for getting rid of unwanted boyfriends and lovers without running the danger of possible retaliation: they say that they have to end the relationship because they really love them and they do not wish to burden them since they are seriously ill (tuberculosis and anaemia being the most popular alleged illnesses).’ In Varsseveld, in the Netherlands, a Turkish girl was stabbed by her boyfriend because she had terminated the relationship (‘Boyfriend stabs girl (15) to death’ in *de Volkskrant* 19-6-2000).
- 40 The Turkish text reads: ‘Seviyordum. Başkasına yâr etmem. Sevdiğim kızın evi terk edip başkasına gitmesini kaldıramadım. O anda vurdum, vurdum. Başka bir şey düşünmedim’ in ‘Bir cinayetin anatomisi’ (*Hürriyet* 7-4-1996). Faraç (1998: 60): ‘The fact that she was killed also had to do with the platonic love that Mehmet, who was going through a fit of jealousy (*kıskançlık krizi*), felt for her’.
- 41 The Turkish text reads: ‘Bizim evde piç doğurtmak niyetindeydi. Kız bizim evde doğursa bizde ne namus ne iman ne din ne haysiyet kalmıyacaktı.’ *Iman* and *din* both mean ‘religion’, and *haysiyet* is the same as *şeref*: see 1.1 and 1.4.
- 42 Gilsenan 1976: 200.
- 43 It is not clear whether the honour killer in the Altun case study was employed.

- 44 Case studies involving an unemployed honour killer are: Ayanoğlu, Türkmen, Koparan, Gürsel, Ardal, and Barut (in this last case, we also know that the accomplice was unemployed). Case studies involving an unemployed accomplice are: Dursun, Şengül, Çetin, and Köksal.
- 45 Van Stolk 1991: 136.
- 46 Pyke 1998: 165. See also Jeanne Doomen in *de Volkskrant* (8-1-1999) on the subject of Meulenbelt (1998).
- 47 Blok 1974; 2000; 2001.
- 48 An example from the *Hürriyet* (30-10-1994): “On her wedding night, Hatice Aydın-Küçük told her husband Yaşar that his best friend Mehmet had raped her. Beside himself, Aydın grabbed his rifle and, despite his family’s pleadings, forced his way into Mehmet’s house. He murdered his best friend and was arrested and taken to the court in Erzurum [...]. In his defence, Yaşar Aydın said: ‘I have never seen such dishonour [*namussuzluk*]. How can anyone be so evil? He got what he deserved. I have purified my *namus*.’”
- 49 Ginat 1979: 198 and Ginat 1979: 199.
- 50 Kressel 1981: 151 point 19.
- 51 Van Nuenen 1997: 59.
- 52 Kressel (1981: 148 note 28) cites E. Marx (1967: 107-III): ‘Elopement is a conventional way of circumventing the difficulties of a match blemished because of a status gap between the parties involved. It is the method normally used where the man is of inferior status.’
- 53 Van der Molen 1983: 26.
- 54 Compare Ginat’s folktale in which the husband kills his daughter because her mother behaved badly (7.2).
- 55 Van der Molen 1983: 26.
- 56 Van der Molen 1983: 26.
- 57 Ginat 1979: 186.
- 58 Pronounced *hodya*.
- 59 Gartmann (1981: 76-77) gives the example of a *dede* (an Alawite cleric) who disowned his daughter when she eloped with a Sunnite.
- 60 Abrahams (1994: 62) writes ‘favourite sister’ in italics to show that he finds it surprising.
- 61 See note 14 in chapter 3.
- 62 Deug 1990: 69.
- 63 Öncü (1981: 185) uses the term ‘facilitating mechanisms’.
- 64 Tezcan 1981: 32.

- 65 Tezcan 1981: 33.
- 66 Magnarella 1982: 396.
- 67 Examples from newspapers: 'Babasını öldürdü' in *Hürriyet* 9-2-1994; 'Tabancayla gelen dram', *Hürriyet* 26-2-1994; 'Tabancayla oyun yine kan döktü' in *Hürriyet* 27-2-1994; 'Evde ölüm oyunu' in *Hürriyet* 11-12-1994; 'Amca kızını öldürdü' in *Hürriyet* 27-2-1995; 'Kardeşini öldürdü' in *Sabah* 13-11-1996.
- 68 Tezcan 1981: 32-33.
- 69 Firing a gun is said to bring good luck (*silâh patlatma uğur sayılır*) (Tezcan 1981: 33-34). See also Yalçın-Heckmann (1991: 212): 'It is a tradition to fire guns in the air during the festivities (of a wedding).'
- 70 Examples are: 'Baba silahıyla anneye kurşun', in *Hürriyet* 5-12-1994; 'Anne katili', in *Hürriyet* 13-12-1994; 'Düğün evi kana bulandı', in *Hürriyet*, 7-3-1995; 'Kına gecesi kana bulandı', in *Hürriyet* 10-7-1995; 'Torununun sünnet düğününde vuruldu', in *Hürriyet*, 16-8-1996; 'Düğün evi kana buladı', in *Hürriyet*, 1-10-1996; 'Düğünde ateş açtı bir çocuğu öldürdü', in *Hürriyet* 6-11-1996.
- 71 Starr (1978: 193): 'Shooting a gun in an inhabited area is against the law, and makes the offender subject to arrest and prosecution for an act in violation of the Turkish Criminal Code. A verdict of guilty makes him liable to both a fine and a jail sentence.' Tezcan (1981: 33): 'Firing a gun is the most common offence in Sinop and the surrounding area.'
- 72 Özgür and Sunar 1982: 352.
- 73 Alkan and Kabdan 1993.
- 74 Vermeulen 1984: 194; De Vries 1990: 41.
- 75 Bovenkerk and Yeşilgöz 1998: 307.
- 76 Den Exter 1993: 31.
- 77 Den Exter points out that Fevzi and his family may originally have come from a different region in Turkey. Internal migration took place on a large scale in Turkey before families ventured to western Europe. Fevzi's family may have come from eastern Turkey, where people are less sympathetic to elopement (verbal communication).
- 78 Yeşilgöz 1992.
- 79 Deug 1990: 51-52.
- 80 See also Delaney 1987: 44.
- 81 De Vries 1987: 182-183.
- 82 Ginat 1979: 193, case study VI.
- 83 Safilios-Rothschild 1969: 213.

Notes to Appendices I, II and III

- 1 Akkaya probably believes that he is only permitted to kill them if he catches them in the act.
- 2 The court records generally contain only the Dutch translations of the words used.
- 3 This case study is reported in P. van Dijken and A. H. Nauta (1978: 227-231).
- 4 This case went to the Court of Appeal: *Nederlandse Jurisprudentie* 1-2-1977, no. 563; 1809.
- 5 This honour killing is described in F. Abrahams, 'The sister who had to die', in *NRC Handelsblad*, 12 October 1993, and also appears in Abrahams 1994: 62-65. I have retained the pseudonyms that Abrahams adopted.
- 6 Koparan speaks good Dutch, but he spoke Turkish during the interrogation, with an interpreter present.
- 7 TCK is the abbreviation of *Türk Ceza Kanunu*, the Turkish Criminal Code. The distinction between 'severe prison sentence' (*ağır hapis*) and 'prison sentence' (*hapis*) is described in section 13. Amongst other things, a 'severe' sentence means that the prisoner must spend part of the sentence in isolation and must work for part of the sentence (TCK 2000: 70-71).
- 8 The death penalty is still passed down, but cannot be implemented without the permission of the Turkish Parliament ('Infaz Kanunu' section 2). In practice, permission is not granted, with the result that prisoners who are condemned to death sit out a life sentence. In 1991, a one-off pardon was granted and the prisoners were released. The Turkish Parliament is at present considering abolition of the death penalty.

Literature

- Abadan-Unat, N. (ed.), *Women in Turkish society*. Leiden: E.J. Brill 1981
- Abrahams, F., "Het zusje dat dood moest", in: idem, *Daar sta je dan. Rechtbankverhalen*. Amsterdam: Uitgeverij Balans 1994, p. 62-65
- Abbrin, Masoeme, "Masoeme. Temmen", in: *Trouw*, 21 August 2000
- Abu-Lughod, L., *Veiled sentiments: honor and poetry in a Bedouin society*. Berkeley-Los Angeles-London: University of California Press 1988 (original edition 1986)
- Akkas, S., *Maar de hoop is niet gebroken: rechtsopvattingen van Turkse jongeren over het Nederlandse strafrechtstelsel en over bepaalde soorten criminele handelingen*. Undergraduate thesis, Willem Pompe Institute for Criminal Sciences, Utrecht 1999
- Aldoğan, Y., "28 genç kız intihar etmiş!", in *Hürriyet*, 3 August 2000, p. 19
- Alkan, M. and R. Kabdan, "Droom of werkelijkheid? Succes onder Turken in Nederland", in: R.S. Gowricharn (ed.), *Binnen de grenzen. Immigratie, etniciteit en integratie in Nederland*. Utrecht: De Tijdstroom 1993, p. 126-141
- Anoniem, "Kırskaçlık cinayetleri. Namusunu temizledi", in: *Nokta*, 31 December 1989, p. 72-78
- Ansary, T., M.T. Yücel and M. Friedman (ed.), *The Turkish Criminal Code, with an introduction by Dr. Nevzat Gürelli*. 2nd impression, New York: New York University 1976 (first published 1965)
- Arıkan, Ç., *Halkın boşanmaya ilişkin tutumları araştırması*. Ankara: T.C. Başbakanlık Aile Araştırma Kurumu Başkanlığı 1996
- Arberry, A.J., *The holy Koran. An introduction with selections*. Londen 1953
- Asena, D., *Kadının adı yok*. Istanbul: AFA yayınları 1987
- Atabek, E., *Kışkırtılmış erkeklik, bastırılmış kadınlık*. Istanbul: Altın kitaplar yayınevi w.y.
- Austin, L., "Vrouwen leiden in Turkije een leuker leven dan mannen. Martine Carton en de charmes van het kale bestaan", in: *Opzij*, 26 (1998) 36-40
- Aykut, O., "Namus ve töre cinayetlerinin Türk hukukundaki uygulaması", in: *Töre cinayetleri. Panel bildirileri*. p. 45-57

- Balaman, A.R., *Evlilik akrabalık türleri. Sosyal antropolojik yaklaşımla*. (Izmir [Turkey] 1982)
- Balaman, A.R., "Family formation and dissolution in rural areas", in: T. Erder (ed.), p. 209-220
- Bates, D.G., "Normative and alternative systems of marriage among the Yörük of Southeastern Turkey", in: *Anthropological Quarterly* 47 (1974) 270-287
- Black-Michaud, J., *Cohesive force. Feud in the Mediterranean and the Middle East*. New York: St. Martin's Press 1975
- Blok, A., *The mafia of a Sicilian village 1860-1960. A study of violent peasant entrepreneurs*. Oxford: Blackwell 1974
- Blok, A., "Eer en de fysieke persoon", in: *Tijdschrift voor Sociale Geschiedenis* 6 (1980) 211-230
- Blok, A., "Rams and Billy-goats: a key to the mediterranean code of honour", in: *Man (n.s.)* 16 (1981) 427-440
- Blok, A., "Zinloos en zinvol geweld", in: H. Driessen and H. de Jonge (ed.), *In de ban van betekenis. Proeven van symbolische antropologie*. Nijmegen: SUN 1994, p. 27-45
- Blok, A., *De Bokkerijders. Roversbenden en geheime genootschappen in de landen van Overmaas (1730-1774)*. Amsterdam: Prometheus, revised edition 1995
- Blok, A., "The narcissism of minor differences", in: *European Journal of Social Theory* 1 (1998) 33-56
- Blok, A., "Les ambiguïtés de l'amitié. A propos de quelques proverbes siciliens", in: Georges Ravis-Giordani (ed.), *Amitiés. Anthropologie et histoire*. Aix-en-Provence: Publications de l'Université de Provence 2000, p. 305-310
- Blok, A., "The blood symbolism of mafia", in: idem, *Honour and violence*. Cambridge: Polity Press 2001, p. 87-102
- Böcker, A., *Turkse migranten en sociale zekerheid: van onderlinge zorg naar overheidszorg?* Amsterdam: Amsterdam University Press 1993
- Boehm, C., *Blood revenge: the anthropology of feuding in Montenegro and other tribal societies*. Lawrence-Kansas: University Press of Kansas 1984
- Bott, E., *Family and social network. Roles, norms, and external relationships in ordinary urban families*. 2nd impression, London 1964 (first published 1957)
- Bourdieu, P., "The sentiment of honour in Kabyle society", in: J.G. Peristiany (ed.), p. 191-241
- Bourdieu, P., *Outline of a theory of practice* [translated by R. Nice], Cambridge: Cambridge University Press. 1977

- Bourdieu, P., "The Kabyle house or the world reversed" in: idem, *Algeria 1960: essays by Pierre Bourdieu*. Cambridge: Cambridge University Press. 1979
- Bovenkerk, F., *Hedendaags kwaad. Criminologische opstellen*. Amsterdam: Meulenhoff 1992
- Bovenkerk, F. and Y. Yeşilgöz, *De maffia van Turkije*. Amsterdam: Meulenhoff 1998
- Bovenkerk, F. and Y. Yeşilgöz, "Multiculturaliteit in de strafrechtpleging?", in: *b en m, tijdschrift voor Beleid, Politiek en Maatschappij* 26 (1999) 230-251
- Brandes, S., "Reflections on honor and shame in the Mediterranean", in: D.D. Gilmore (ed.), *Honor and shame and the unity of the Mediterranean*. Washington 1987, p. 121-135
- Breteau, Cl. and N. Zagnoli, "Le système de gestion de la violence dans deux communautés rurales méditerranéennes: la Calabre méridionale et le N.-E. Constantinois", in: Verdier, R., *La Vengeance. Études d'ethnologie, d'histoire et de philosophie. Volume 1. Vengeance et pouvoir dans quelques sociétés extra-occidentales*. Paris: Edition Cujes & CNRS 1980, p. 43-75
- Brouwer, L. et al. *Andere tijden, andere meiden. Een onderzoek naar het weglopen van Marokkaanse, Turkse, Hindostaanse en creoolse meisjes*. Utrecht: Van Arkel 1992
- Brouwer, L., *Meiden met lef. Marokkaanse en Turkse weggoopters*. Amsterdam: VU Uitgeverij 1997
- Burke, P., *History and social theory*. Cambridge: Polity Press 1992
- Canatan, K., *Ik ga terug, mijn ouders blijven*. Den Haag: Stichting Inspraakorgaan Turken in Nederland [Forum to represent Turks in the Netherlands] 1995
- Delaney, C., "Seeds of honor, fields of shame", in: D.D. Gilmore (ed.), *Honor and shame and the unity of the Mediterranean*. Washington 1987, p. 35-49
- Delaney, C., "The Hajj: sacred and secular", in *American Ethnologist* 17 (1990) 513-530
- Delaney, C., *The seed and the soil. Gender and cosmology in Turkish village society*. Oxford: University of California Press 1991
- Deug, F., *En dan ben je pas echt ver van huis. Turkse en Marokkaanse vrouwen en meisjes over seksueel geweld en de hulpverlening*. Utrecht: Stichting Tegen Seksueel Geweld [Foundation against Sexual Violence] 1990

- Develioğlu, A., "Turkse tragedies. Hulpverleners in het nauw", in: *Buitenlanders Bulletin* 18 (1993) 5-7
- Dijken, P. van, and A.H. Nauta, "Bloed- en eerwraak onder Turken in Nederland", in: *Algemeen Politieblad* 127 (1978), 227-231
- Dinçel, G., "Kimin namusu: tabii ki erkeğin", in: *Çırak* [law faculty students' newspaper, University of Ankara] 2 (1993) 2-4
- Donkelaar, W. van, *Het culturele delict Turkse eerwraak. Houden politiefunctarissen, officieren van justitie, raadsmanen en rechters rekening met de culturele achtergrond van de verdachte van het delict Turkse eerwraak?* Undergraduate thesis in law, Amsterdam University, 20 September 2000
- Douglas, M., *Purity and danger. An analysis of concepts of pollution and taboo*. London: Routledge and Kegan Paul 1966
- Driessen, H., "Een kwestie van mediterrane eer", in: *Volkskundig Bulletin* 23 (1997) 197-214
- Dundes, A., J.W. Leach, B. Özkök, "The strategy of Turkish boys' verbal dueling rhymes" in J.J. Gumperz and D. Hymes, *Directions in sociolinguistics. The ethnography of communication*. Oxford 1986, p. 130-161 (first published 1972)
- Durham, M.E., *Some tribal origins, laws and customs of the Balkans*. London: George Allen and Unwin 1928
- Eck, C. van, "Eerwraak bij Turken", in: *Discorsi. Faculteitsblad van de PSCW, faculteit der politieke en sociaal-culturele wetenschappen van de UvA* 30 (1996) 24-25
- Eck, C. van, "Hoe Zeynep het leven liet. Een geval van eerwraak bij een Turkse familie in Nederland", in: *Tijdschrift voor Criminologie* 39 (1997a) 217-234
- Eck, C. van, "Ik heb mijn eer gezuiverd. Een Turkse eerwraak in Nederland", in: *Soera. Midden-Oosten Tijdschrift* 5 (1997b) 53-56
- Eck, C. van, "De zaak van.... Eerwraak in Nederland", in: *Perspectief, informatie- en opinieblad voor de jeugdbescherming* 6 (1998a) 21
- Eck, C. van, "Ebru geeft zich aan bij de politie. Een geval van eerwraak bij Turken in Nederland", in: *Delikt en Delinkwent, tijdschrift voor strafrecht* 28 (1998b) 741-749
- Eck, C. van, "Over het Turkse begrip namus", in: H. Driessen and H. de Jonge, *Miniature etnografiche*. Nijmegen: SUN 2000a, p. 110-113
- Eck, C. van, "Dilemma's in de rechtszaal. Besprekingsartikel", in: *Tijdschrift voor Criminologie*, 42 (2000b) 77-82
- Eck, C. van, "Eerwraak in Turkije. Protest tegen de traditiemoorden", in: *Justitiële Verkenningen*, 26 (2000c) 87-97

- Eck, C. van, "Het hennafeest. Een geval van eerwraak bij Turken in Nederland", in: *Psychologie en Maatschappij* 93, 24 (2000d) 338-348
- Eck, C. van, *Door bloed gezuiverd. Eerwraak bij Turken in Nederland* (doctoral dissertation, Amsterdam University). Published by Bert Bakker, Amsterdam, 2001a
- Eck, C. van, "Eerwraak in Turkije" in *Proces. Tijdschrift voor berechting en reclassering. Themanummer Cultureel verweer in strafzaken*. 80e jrg, nr. 11/12 (2001b), 185-188
- Eck, C. van, "Een poging tot eerwraak in Veghel (Nederland)" in *Delikt en Delinkwent. Tijdschrift voor strafrecht*, nr. 32/2 (2002a), 162-174
- Eck, C. van, "Honour killings among Turks in the Netherlands", in: *Turkish Studies*, april 2002b
- Eck, C. van, "Een geval van eerwraak in Nederland (Veghel)" in Susan Rutten (red.), *Recht van de Islam* 19 (RIMO, Maastricht 2002c), 20-37
- Elias, N., *Die höfische Gesellschaft. Untersuchungen zur Soziologie des Königtums und der höfischen Aristokratie mit einer Einleitung*, Soziologie und Geschichtswissenschaft, Berlin 1969
- Elias, N., and J.L. Scotson, *De gevestigden en de buitenstaanders. Een studie van de spanningen en machtsverhoudingen tussen twee arbeidersbuurten*. Den Haag: Het Spectrum 1985
- Enoch, M. David, "Sexual Jealousy", in: *British Journal of Sexual Medicine* (January 1980) 30-34
- Erder, T. (ed.), *Family in Turkish society. Sociological and legal studies*. Ankara: Turkish Social Science Association 1985
- Ergil, D., "A sociological analysis of honor crimes in Turkey", in: *Balkan Studies* 21 (1980a) 403-439
- Ergil, D., *Türkiye'de terör ve şiddet*. Ankara: Turhan Kitabevi 1980b
- Everaert, H.A. and H.E. Lamur, *Alles wat geheim is, is lekker. Seksuele relaties en beschermingsgedrag van Turkse mannen*. Amsterdam: Het Spinhuis 1993
- Exter, J. den, *Diyanet. Een reis door de keuken van de officiële Turkse islam*. Beverwijk: Centrum Buitenlanders Peregrinus 1990
- Exter, J. den, "Regionale herkomst van Turken in Nederland" in *Migrantenstudies* 9 (1993) 18-34
- Exter, J. den and E. Kutlu, "Emirdağ: over de effecten van migratie op een Turks district" in *Migrantenstudies* 9 (1993) 23-33
- Faraç, M., *Töre kışkacında kadın. İnceleme*. Istanbul: Çağ Pazarlama A.Ş., Çağdaş yayınları 1998

- Gartmann, H., *Zur Situation der Frau im gecekondü*. Berlin 1982 (Islamkundliche Untersuchungen vol. 63)
- Geçer, Y., *Erfelijkheidsvoorlichting bij Turken en Marokkanen in Nederland*. Soestdijk: VSOP 1995
- Gilmore, D.D., "Honor, honesty, shame: male status in contemporary Andalusia", in: D.D. Gilmore (ed.), *Honor and shame and the unity of the Mediterranean*. Washington D.C.: American Anthropological Association 1987, p. 90-103
- Gilsenan, M., "Lying, honor, and contradiction", in: Bruce Kapferer (ed.), *Transactions and meanings: directions in the anthropology of exchange and symbolic behavior*. Philadelphia: ISHI 1976, p. 191-219
- Ginat, J., "Illicit sexual relationships and family honour in Arab society" in S. Giora Shoham and Anthony Grahame (ed.), *Israel studies in criminology* 5. Tel Aviv: Turtledove Press 1979, p. 179-202
- Giovannini, M.J., "Female chastity codes in the circum-Mediterranean: comparative perspectives", in: D.D. Gilmore (ed.), *Honor and shame and the unity of the Mediterranean*. Washington D.C.: American Anthropological Association 1987, p. 61-75
- Goffman, E., "The nature of deference and demeanor", in: *American Anthropologist* 58 (1956) 473-502
- Gosewehr D., and A. Verheijden, *Eerwraak en bloedwraak onder Turken in Nederland*. Undergraduate thesis in criminology, Amsterdam University, July 1983
- Haksun, N., *Meyro*. pre-1973. (precise date and place of publication unknown)
- Haksun, N., *Kutsal Ceza*. Doyuran Matbaası, 1975 (first published 1973)
- Hermet, A., "Au nom de l'honneur. L'affaire Nazmiye reprise", in: *Migrations Société* 9 (1997) 47-52
- Heyd, U., *Studies in old Ottoman criminal law, edited by V.L. Ménage*. Oxford: University Press 1973
- Holy, L., *Kinship, honour and solidarity. Cousin marriage in the Middle East*. Manchester: Manchester University Press. 1989
- Honneur & violence. Fatalité ou conjoncture pour les femmes Turques?* [Proceedings of a symposium held on 12 and 13 December 1997, and organised by 'Elele' and UNESCO, on the subject of "Migrations et cultures de Turquie"]. Paris: Elele, Rue de la Pierre-Levée 75011 Paris, September 1998
- Joris, L., "De Turkse truc. Gastarbeiders en het strafrecht", in: *Haagse Post* 68 (1981) 30-34

- Jungschleger, I., "Zwangerschap was geheim van gevallen meisje", in: *de Volkskrant*, 21 March 1997
- Juynboll, Th.W., *Handleiding tot de kennis van de Mohammedaansche Wet, volgens de leer der sjâfi'itische school*. 4th impression, Leiden: E.J. Brill 1930
- Kağıtçıbaşı, Ç., *Sex roles, family and community in Turkey*. Bloomington: Indiana University Turkish Studies 1982
- Kardam, F., "Töre cinayetleri üzerine bazı düşünceler", in: *Töre cinayetleri. Panel bildirileri*. 1999, p. 87-96
- Knoops, G.G.J., *Psychische overmacht en rechtsvinding. Een onderzoek naar de strafrechtelijke, forensisch-psychiatrische en psychologische grenzen van psychische overmacht*. Deventer: Gouda Quint 1998
- De Koran. Uit het Arabisch vertaald door prof. dr. J.H. Kramers. Bewerkt door drs. Asad Jaber and dr. Johannes J.G. Jansen*. 15th revised edition, Amsterdam 1992
- Kramers, J.H., *De koran. Uit het Arabisch vertaald*. 13th impression Amsterdam 1956
- Kressel, G.M., "Soricide/filiacide: homicide for family honour", in *Current Anthropology* 22 (1981) 141-152
- Kudat, A., "Institutional rigidity and individual initiative in marriages of Turkish peasants" in *Anthropological Quarterly*, 47 (1974) 288-303
- Magnarella, P.J., *Tradition and change in a Turkish town*. New York: Halsted Press 1974
- Magnarella, P.J., "Civil violence in Turkey: its infrastructural, social and cultural foundations", in: Kağıtçıbaşı, Ç., 1982, p. 383-401
- Malinowski, B., *Crime and custom in savage society*. London: Kegan Paul-Trench-Trubner 1978 [first published 1926]
- Mansur, F., *Bodrum. A town in the Aegean*. Leiden: E.J. Brill 1972
- Marx, Emanuel, *Bedouin of the Negev*. Manchester: Manchester University Press. 1967
- Marx, Emanuel, *The social context of violent behaviour: a social anthropological study in an Israeli immigrant town*. London: Routledge and Kegan Paul 1976
- Matlé, A., Sonay A. *Hier wil ik wonen*. Amsterdam: Archipel 1998 (translation of: *Sonay A. Hier will ich leben*. München: Bertelsmann 1996)
- Meeker, M., "Meaning and society in the Near East: examples from the Black Sea Turks and the Levantine Arabs (I + II)" in: *International Journal of Middle East Studies* 7 (1976) 243-270, 383-422
- Mernissi, F., *Achter de sluier*, Amsterdam: Sara 1985

- Mesters, B., "Je zegt meer als je de dingen niet bij naam noemt" in: *de Volkskrant* 1 August 1998
- Meulenbelt, A., et al., *De eerste sekse. Meninge n over mannelijkheid*, Amsterdam: Van Genne p 1998
- Molen, F. van der, *Turkse eer- en bloedwraak*, undergraduate thesis, Netherlands Police Academy, Den Haag 1983
- Moore, Sally F. and B.G. Myerhoff, *Secular ritual*, Assen-Amsterdam: Van Gorcum 1977
- Muijen, A., "De kloof. Botsingen tussen de islamitisch denkende ouders en hun westers denkende kinderen: 'Of zij zijn ongelukkig of ik ben het.' Een verslag van drie vrouwen uit het islamitische opvanghuis", in: *Haagse Post*, 18 August 1990, p. 30-39
- Nauta, A.H.; see Dijken, P. van, and A.H. Nauta, 1978
- Nauta, A.H., *Eer, eerverlies, eerwraak en bloedwraak bij Turken in Nederland en Turkije*, Studiecentrum Rechtspleging, Zutphen 1991, research material
- Necatigil, B., *Edebiyatımızda isimler sözlüğü*, Varlık yayınları, 13th impression Istanbul 1989
- Nellestein, A., "Achtergronden van Turkse ontvoeringszaken", in: *Algemeen Politieblad*, 130 (1981) 51-56
- Nesin, A., *Tek yol* (1978)
- Nuene n, F. van, *Gestolen maagden. Vrijwillige schakingen en huwelijken in een Turks dorp*, undergraduate thesis in cultural anthropology, Nijmegen 1996
- Öncü, A., "Turkish women in professions: why so many?" in N. Abadan-Unat (ed.), p. 181-193
- Önder, A., "Das türkische Strafrecht", in: E. Mezger, A. Schönke & H.H. Jescheck, *Das ausländische Strafrecht der Gegenwart. Band IV. Amerika. Norwegen. Türkei*, Berlin: Duncker & Humblot 1962, p. 417-599
- Ortner, S., "Theory in anthropology since the sixties", in: *Comparative Studies in Society and History* 26 (1984) 126-166
- Os, G. van, *De vrouwen van de doden. Betekenis en beleving van het weduwschap in Extremadura (Spanje)*. Amsterdam: Centrale Drukkerij Amsterdam University 1997
- Özgen, E., "Early marriage, brideprice and abduction of women", in: T. Erder (ed.), 1985, p. 313-350

- Özgür, S. and D. Sunar, "Social psychological patterns of homicide in Turkey: a comparison of male and female convicted murders", in: Kağıtçıbaşı, Ç., 1982, p. 349-381
- Peristiany, J.G. (ed.), *Honour and shame: the values of Mediterranean society*. London: Weidenfeld and Nicolson 1966
- Petersen, A., *Ehre und Scham: das Verhältnis der Geschlechter in der Türkei*, Berlin: Express-Edition 1985
- Pitt-Rivers, J., "Honour and social status", in: J.G. Peristiany (ed.), 1966, p. 19-77
- Pitt-Rivers, J., "Honor", in: David L. Sills (ed.), *International Encyclopedia of Social Sciences* 6, 1968, 503-511
- Pitt-Rivers, J., *The fate of Shechem or the politics of sex. Essays in the Anthropology of the Mediterranean*. Cambridge: Cambridge University Press. 1977
- Pye, K.D., "Mannelijkheid en klasse", in: Meulenbelt, A., et al., *De eerste sekse. Meningen over mannelijkheid*. Amsterdam: Van Genneep 1998, p. 158-190
- Rossum, J. van & J. Hoogendoorn, "Eerwraak: een uitheems delict in de Nederlandse rechtspraak", in: *Proces, maandblad voor berechting en reclassering* 76 (1997) 144-148
- Rossum, J. van, *Eer en eerwraak. Een vergelijkend onderzoek naar de opvattingen van eer en eerwraak onder Turken, Marokkanen en Surinamers*. Undergraduate thesis in criminal law. Universiteit Utrecht: Willem Pompe Institute for Criminal Sciences. 31 January 1997
- Rossum, W. van, *Verschijnen voor de rechter. Hoe het hoort en het ritueel van Turkse verdachten in de rechtszaal*. Amsterdam: Duizend & Een 1998
- Ruggi, S., "Commodifying honor in female sexuality. Honor killings in Palestine" in *MER (Middle East Report)*, 28 (1998) 12-15
- Safilios-Rothschild, C., "'Honour' crimes in contemporary Greece" in *The British Journal of Sociology* 20 (1969) 205-218
- Şahin, C., "Törelerin etkisiyle işlenen adam öldürme suçlarının ceza hukuku açısından değerlendirilmesi" in *Töre cinayetleri. Panel bildirileri*, p. 35-43
- Santing, F., "De dood als straf voor te grabbel gooien van 'eer' familie", in: *NRC Handelsblad*, 9 November 1996
- Santing, F., "Rechterlijk begrip voor moord op oneerbare vrouw", in: *NRC Handelsblad*, 10 December 1998

- Sarıhan, Ş., “Namus cinayetlerinde avukatların sorumluluğu” in *Töre cinayetleri. Panel bildirileri*. p. 59-69
- Schacht, J., “Zinâ”, in: *Enzyklopaedie des Islâm*. Leiden: E.J. Brill-Otto Harrassowitz, Leipzig 1934
- Schiffauer, W., *Die Gewalt der Ehre, Erklärungen zu einem Türkisch-Deutschen Sexualkonflikt*, Frankfurt-am-Main: Suhrkamp 1983
- Schiffauer, W., *Kulturelle Charakteristika als Bedingungen interkultureller Kommunikation. Die türkische Minderheit*, Weinheim and Basel 1986
- Schiffauer, W., *Weltbild und Selbstverständnis der Bauern von Subay. Eine Ethnographie*, doctoral dissertation, Freie Universität Berlin, Berlin 1987
- Schneider, J., “Of vigilance and virgins: honor, shame and access to resources in Mediterranean societies”, in: *Ethnology* 10 (1971) 1-24
- Shakespeare, W., *Othello. Tragedie in vijf bedrijven in de vertaling van Bert Voeten*. Amsterdam: De Bezige Bij 1964
- Simmel, G., *Soziologie. Untersuchungen über die Formen der Vergesellschaftung*, Frankfurt am Main 1992 [first published 1908]
- Sirman, N., “State, village and gender in Western Turkey”, in: A. Finkel & N. Sirman (ed.), *Turkish state, Turkish society*. London 1990
- Soest, M. van and A. Holtrop, “Ik voel me liberaal islamitisch, of dat nou bestaat of niet”, in: *Vrij Nederland*, 5 January 1991, p. 48-49
- Starr, J., *Dispute and settlement in rural Turkey: an ethnography of law*. Leiden: E.J. Brill 1978
- Stirling, P., *Turkish village*. London: Weidenfeld & Nicolson 1965
- Stolk, B. van, *Eigenwaarde als groepsbelang*. Houten-Antwerpen: Bohn/Stafleu/VanLoghum 1991
- Tanrıyar, E. and A. Baştürk, “Fena halde zina. Zina davalarında patlama”, in: *Nokta*, 19 July 1987, p. 48-56
- Tezcan, M., *Kan dâvâları. Sosyal Antropolojik yaklaşım*. expanded and revised 2nd edition, Ankara 1981
- Töre Cinayetleri. Panel Bildirileri*. Published by T.C. Başbakanlık Kadının Statüsü ve Sorunları Genel Müdürlüğü, Ankara, December 1999
- Türk Ceza Kanunu, en son değişiklikleriyle*. [The Turkish Criminal Code, with most recent amendments] Ankara: Yetkin Yayınları 2000
- Ünsal, A., “Family ties versus the law: the bloodfeud tradition in Turkey”, in: T. Erder (ed.), 1985, p. 221-244
- Ünsal, A., *Tuer pour survivre: la vendetta*. Paris: L'Harmattan 1990

- Veen, J. van, "De verschrikkelijke verliefdheid van Raman T.", in: *Vrij Nederland* 9 September 1989
- Vermeulen, H., *Etnische groepen en grenzen. Surinamers, Chinezen en Turken*. Weesp: Het Wereldvenster 1984
- Vloten, E. van, and S. van de Wetering, "Het strafrecht in de Islamitische wereld", in: *Ars Aequi*, 29 (1980) 754-763
- Vries, M. de, *Ogen in je rug. Turkse meisjes en jonge vrouwen in Nederland*. Alphen aan de Rijn: Samson 1987
- Vries, M. de, *Roddel nader beschouwd*. Leiden: COMT 1990
- Vries, M. de, "Turkse meisjes in Nederland: de veranderende rol van roddel", in: *Migrantenstudies* 9 (1993) 32-45
- Wertheim, W.F., "Society as a composite of conflicting value systems", in: idem, *East-west parallels. Sociological approaches to modern Asia*. Van Hoeve, Den Haag 1964, p. 23-37
- Wiersinga, H., "Dossier van een verloren zaak", in: *Delikt en Delinkwent, tijdschrift voor strafrecht* 23 (1993) 528-545
- Wikan, U., "Shame and honour: a contestable pair", in: *Man, n.s.* 19 (1984) 635-652
- Wolf, E.R., *Peasants*. New Jersey: Prentice Hall 1966
- Women in Turkey/Türkiye'de kadın* 1999, published by the 'General Directorate on the Status and Problems of Women/Kadının Statüsü ve Sorunları Genel Müdürlüğü', Ankara 1999
- Wormhoudt, R.H., "Culturele achtergronden: strafuitsluitingsgronden?", in: *Proces. maandblad voor berechting en reclassering* 65 (1985) 329-337
- Yalçın-Heckmann 1991, *Tribe and kinship among the Kurds*. Frankfurt am Main-Bern-New York-Paris: Peter Lang 1991
- Yaşar Kemal, *Yılanı öldürseler*, 11th impression Istanbul: Toros yayınları 1993 [first published 1976]
- Yerden, I., *Trouwen op z'n Turks. Huwelijksprocedures bij Turkse jongeren in Nederland en hun strijd om meer inspraak*. Utrecht: Jan van Arkel 1995
- Yeşilgöz, Y. and L.M. Coenen, "Opvattingen over eer en eerbescherming onder Turken", in: *Proces. maandblad voor berechting en reclassering* 72 (1992) 25-31
- Yeşilgöz, Y., *Allah, Satan en het recht. Communicatie met Turkse verdachten*. Arnhem: Gouda Quint 1995
- Yeşilgöz, Y., "Namus: eer en eerherstel onder Turken", in: *Leidschrift* 12 (1996) 111-130

Yeşilgöz, Y., see Bovenkerk, F. and Y. Yeşilgöz, 1998

Yıldız B., *Reşo ağa*, 12th impression Istanbul: Cem yayınevi 1983 [first published 1968]

Index

- abortion 172
adultery 176-177
Abdullah 162, 191, 204
Akkaya 39, 66, 76, 78, 96,
149-150, 157, 179, 180,
223-225
Altuğ 13, 52, 136, 158, 170, 173,
189, 193-194, 197, 210, 219
Altun 78, 146-147, 149
apology 168, 172
Ardal 126-128, 207, 219
Asiye 110, 116, 173-174
'at, avrat, silah' 210
Ayanoğlu 73-74, 76, 78-80,
96-97, 109, 160, 186, 191,
210, 219
baby 34, 51-52, 128, 150, 159,
180-181, 198, 241
Bahadır 28, 48, 107
Barut 45, 78, 163, 211, 218,
226-229
başlık 117, 160
Biber 39, 78, 80-84, 88, 148,
150, 171, 201, 216
Bitlis 11, 157
Bitlis 1 163, 237-238
Bitlis 2 173, 238-239
Bitlis 3 95, 238-239
Bitlis 4 105, 161, 239
blood money, *see* diyet
blood revenge 10, 32-33, 47, 79,
169, 171
boarding school 159
boynuzlu 143
brideprice, *see* başlık
camouflage 35-36
Çakıroğlu, Nurdan 153
Çalışlar 68-69
Çetin 50, 66, 78, 85-87, 90,
142, 168, 187, 192-193,
196-197, 200-201, 211, 217
çeyiz 117, 158
curse, *see* insult
Dağ 11, 77-78, 92-93, 196
damat 55, 99
defiance 197
Denmark 48, 53-54, 56, 178,
195
disguised 93-94
diyet 33, 171
Dursun 13, 15-18, 24-26, 32-33,
35-36, 44-46, 48, 64, 71-72,
76, 78-79, 87-88, 90-92,
96, 114, 168, 170, 179, 182,
187, 192, 200, 208-209,
219
elopement 99, 104-122, 140,
158, 163, 173, 176, 182
Elif 109-110, 120
Elmas 66, 85, 87, 122-125, 161,
167, 170, 203, 205-207,
210, 215
Ercan 78-79, 142-145, 186,
198-199

- Euphrates 60, 67, 79, 95, 162, 205
 evlatlıktan reddetmek 161
 extended honour crime 155
- Faraç, Mehmet 69-70
 family council 78, 207
 feud 10, 67, 168
- gossip 159, 199
 gurbet 213
 Gürsel 75, 78, 170-171, 189, 202-203, 206, 208, 213, 229-230
 gurur 21, 105, 154, 163
- hac 20
 hafız 20
 hair 51
 Haksun, Necati 9, 38, 154
 haysiyet 21, 39
 henna 77
 hero 190
 hired assassin 78, 87, 91
- iffet 21
 imam marriage 106, 111-112, 115
 insult 142-145, 198
 irz 21, 44
 islam 37, 126, 159, 168, 194
 isolation 189
- Kezban 153-154
 kinship marriage 29-30
 knifing in the square 65, 67-68, 70, 74, 77, 180, 196
 Köksal 13, 78, 89-90, 137-142, 157, 160, 172, 186, 196, 200, 219
- Koparan 52, 79, 103, 179, 201-202, 212, 215, 230-232
 Koran 19, 37, 39
 küfür, *see* insult
 küs 167-168
- mediation 178
 mesele, namus – 10, 19, 184, 204
 minor 78, 80, 97, 135, 173
 multiple honour killing 55
- namuslu 19, 30, 44, 49, 105
 nose 170
- Othello 193-194, 202
 oturakalma 106
- pathological 146-151
 pislik 48, 66-67, 77
 preventive honour killing 89
- rape 176, 178, 216
 rape claim 49, 137
 Reşo Ağa 43, 77, 189
 ritual 74, 78, 100
- saygı 19, 116
 Sefiye 111, 115, 173
 Şener 174-176, 201
 Şengül 13, 78, 85, 88, 165, 167, 172, 186, 197, 200-202, 210, 233-235
 son-in-law, *see* damat
 stabbing in the square, *see* knifing –
 stoning 38-39, 128
 suicide 163
- Tekin 13, 45, 72, 78, 80, 118-120, 122, 170, 185,

- 189-190, 192, 203, 208,
213, 215-216
- Tahrik 35, 67, 70, 243
- tarla 31-32
- töre 31, 67
- tractor 70-71, 77, 94
- trousseau, *see* çeyiz
- Türkay 112, 173
- Turkish Criminal Code 34, 70,
177, 241-244
- Türkmen 39, 45, 78-79, 87,
129-131, 161-162, 194, 201,
208, 216
- under-age, *see* minor
- Ülkü 52, 109
- Utlı 39, 56, 77-78, 95, 164,
190, 192
- Uzun 52, 75, 85, 105, 132-135,
157, 159, 186, 189, 193, 198,
201, 203, 214, 219
- Vries, Marlene de 192, 219
- Yeşilgöz, Yücel 20, 48, 54, 95,
148, 161, 212
- Yiğit 52, 78-80, 100-103, 159,
169, 179, 188, 195, 199, 210
- Yılanı öldürseler 45
- Yıldız, Bekir 43, 77, 189
- Yurter 151-154
- zina 37, 176