

Montana Tech Library

## Digital Commons @ Montana Tech

---

Bachelors Theses and Reports, 1928 - 1970

Student Scholarship

---

Spring 5-1959

### The Mono-Rail Timber Transfer

James D. Wallace

Follow this and additional works at: [https://digitalcommons.mtech.edu/bach\\_theses](https://digitalcommons.mtech.edu/bach_theses)



Part of the [Mining Engineering Commons](#)

---

Mining 72  
Spring Semester 1959

Machine Design  
THE MONO-RAIL TIMBER TRANSFER

A Project Paper  
Submitted to  
Professor Koshler S. Stout

by  
James D. Wallace

May, 1959  
Montana School of Mines  
Butte, Montana

Mining 72  
Spring Semester 1959

Machine Design  
THE MONO-RAIL TIMBER TRANSFER

29986

A Project Paper  
Submitted to  
Professor Koehler S. Stout

by

James D. Wallace

May, 1959  
Montana School of Mines  
Butte, Montana

W/n 96-146831

Montana School of Mines  
Butte, Montana  
May, 1959

Professor Koehler S. Stout  
Mining Department  
Montana School of Mines  
Butte, Montana

Dear Professor Stout:

I take pleasure in submitting the following report on The Mono-Rail Timber Transfer to you for fulfillment of the requirement for Mining 72, Special Investigations.

This report advanced one of George L. Wilhelm's ideas that was included in his 1958 report to the Mining Department of the Montana School of Mines entitled A Portfolio of Advanced Mining Equipment Ideas.

My report covers the desire and need for a practical machine of this type to save labor, time and fatigue in underground timber transportation. A design is suggested including description, sequence of operation, design details and calculations.

It is envisioned that someday this idea or parts of it may materialize into an actual, workable, efficient, machine. I will be able to say at that time that my contribution has been more than just toward course completion.

Sincerely yours,

James D. Wallace

## TABLE OF CONTENTS

LETTER OF TRANSMITTAL . . . . .	11
INTRODUCTION . . . . .	1
DESCRIPTION OF TIMBER TRANSFER . . . . .	4
SEQUENCE OF OPERATION . . . . .	6
DESIGN DETAILS . . . . .	10
Rear Frame . . . . .	10
Fore Frame . . . . .	11
Counterbalance . . . . .	11
Brake . . . . .	12
Grasping Jaws. . . . .	12
Hoist . . . . .	13
CALCULATIONS . . . . .	15
Rear Frame . . . . .	15
Front Frame . . . . .	15
Counterbalance . . . . .	15
Power Screw for Counterbalance . . . . .	15
Controls . . . . .	16
Hinge Pins . . . . .	16
Brake . . . . .	17
Air Motor . . . . .	17
Total Weight . . . . .	18
Hoist Cable . . . . .	18

## THE MONO-RAIL TIMBER TRANSFER

### Introduction

While paging through a 1958 report written by George Wilhelm, then a graduate student at the Montana School of Mines, I was greatly impressed by a mono-rail timber lift he had envisioned. Mr. Wilhelm's report was dedicated to advanced designs for different pieces of mining machinery. He submitted no details; but, a drawing and description to relay the idea to the reader was offered.

I chose this timber lift for an investigation report because of its peculiar interest and possibilities of becoming a useful machine.

Various machines of all sizes transfer packaged timber on the surface, however, underground, all these machines are too bulky to operate. Handling unpackaged posts and lagging piece-by-piece, by hand labor is the resulting procedure. Should some means be devised to aid the laborer in the removal of packaged timber from the cage and in the placing of the package on rail cars, vast quantities of time and timbering expense might be saved.

In answer to this need I have accepted Mr. Wilhelm's idea as an inspiration, contributed my own ideas which produced some changes, and added a fair degree of detail.

I do not say I have produced the finished design for an unfailing product, far from it. I have merely advanced the idea one step up the stairway to reality.

The building of a working model would be necessary to assure that each component is matched to its adjacent parts -- free and

capable of doing its designated purpose. Because time did not allow me to bring such a model into existence, tests could not be run for weaknesses, over strengths, malfunctioning parts, and illogical design. I have no doubt changes would be needed in my presentation before a workable machine could be created.

I would be pleased if someone were to continue the project from where I ceased and someday produce an actual machine to accomplish the job I intended for my design.

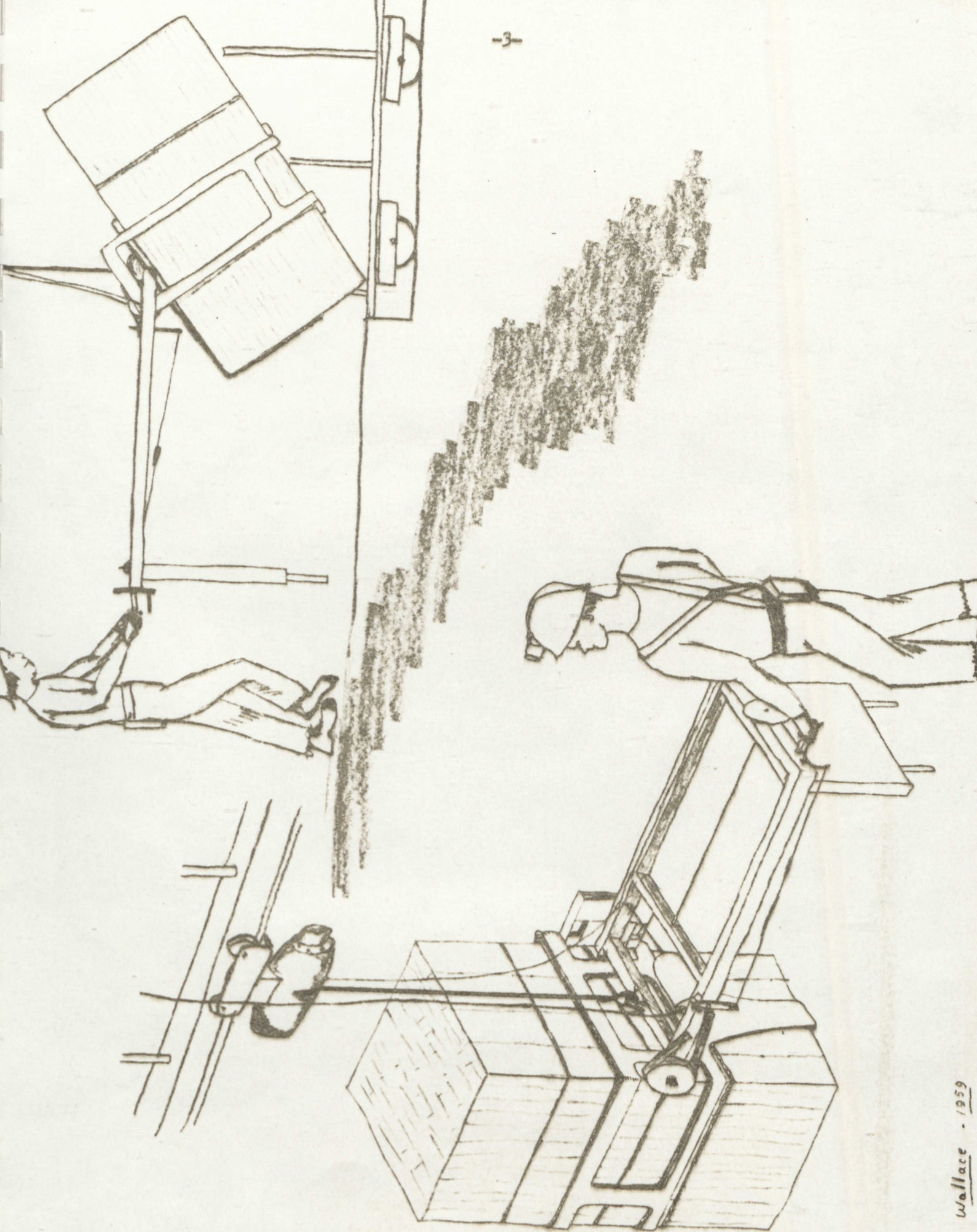



### Description of Timber Transfer

The timber transfer is constructed on a two-piece channel iron frame that is hinged in the center.

The front framework consists of grasping arms with one moveable set of arms sweeping a horizontal arc. The sweeping arm allows the two sets of forks to encircle the load and close tightly around it. A pallet foot slides under the load to detain it from sliding out of the grasping arms.

The rear section of the frame is primarily a horizontal rectangle with one end suspended from an overhead mono-rail hoist. The grasping jaws are hinged to the suspended end of the rectangle, placing the hoist hook effectively in the center of the device.

A moveable counter balance, positioned by a power screw, can be placed at varied distances from the hoist hook. Consequently, whether the transfer is empty or carrying a heavy load, the counterbalance may always be situated so that the machine will maintain a controllable position.

To control the hinged frame, a manually regulated band brake is employed. The hinge pins joining the two frame divisions are securely fastened to the front section. The brake drum is secured to an extension of the left hinge pin while the band is rigidly held to the rear frame. By changing the tension on the brake band, the vertical swing of the front section can be slowed or stopped as desired.

Pressure exerted on a rear extension of the moveable grasping jaw causes it to swing on its axial pin and clamp the timber load between

the jaws. A low angle helix, power screw turned by a sizeable air motor exerts the desired pressure on the jaw. By utilizing a hollow motor shaft mating directly to the screw, when the shaft rotates and the screw is held stationary, longitudinal displacement will occur. The air motor is mounted on the rear framework close to the brake drum with the shaft extension pointing to the opposite side of the frame. The power screw extends through a hole in the channel iron frame and presses against a highly reinforced face plate fastened to the rear extension of the swinging jaw. Because the face plate must move vertically when the brake is released, the plate moves past the stationary end of the power screw. If a large ball-bearing is mounted in a socket in the power screw friction should be cut to an operational limit.

In the extreme rear of the transfer is the operator's position. Only one man is required for complete operation. Two hand grips, one on each side, inset from the edge, will be used to control the device as it is suspended from the hoist. Always facing the machine and looking forward, the operator will control the hoist with his right hand while the left will operate the brake and the air motor. A twist grip, similar to a motorcycle throttle control, will operate electric hoist "raise" and "lower" buttons mounted inside the channel frame. A curved lever squeezed against the handle grip will tighten the brake band and assure an upright load until dipping is desired. Mounted immediately forward of the brake lever and on top of the frame, is situated a three position lever control for the air motor. Center

position is off while the other two will cause forward and reverse action. The lever regulates an airplane control cable fastened to the air motor. Positions of the lever govern corresponding positions of the internal control mechanism on the motor. Located midway between the hand grips is a wheel, controlled by a horizontal peripheral hand grip similar to the previous two. This wheel is connected to the power screw which moves the counterbalance. Being free to turn, while the balance weight is held in place by the side frames, the screw rotates and causes the mating hole in the weight to follow the helix. Since the mechanism is comparatively free of friction, the helix has a high angle and moves the counterweight rapidly as the crank is turned.

When the transfer is idle, short pipe legs, protruding down from the counterweight, keep the entire machine on an even keel and in position for future use.

#### Sequence of Operation

Let the sequence commence with the operator approaching the idle machine which is underneath the mono-rail and resting on the ground, but out of the highly traveled lanes of movement near the shaft. The cage has just lowered a timber package which the operator desires to place on a near-by timber car.

The following will be written in instruction form -- such as the operator might be thinking as he accomplishes the cyclic procedure:

1. Lock the brake and raise the hoist slowly to check the counterbalance position.

2. If adjustment is required for the weight, the right hand turns the control handle until properly positioned.
3. Continue to raise the hoist until all obstructions are cleared.
4. Move on the mono-rail to the shaft.
5. Open the safety gate, barring the cage, should it be closed.
6. Move forward with the grasping jaws just wide enough to enclose the timber.
7. Properly position the jaws around the package, with the pallet foot fully underneath it.
8. Clamp jaws tightly around package, lock brake and raise load slightly.
9. Adjust counterbalance to offset additional load and raise machine to convenient height.
10. Back out of shaft, turn and proceed to properly placed timber car. (Car must be located beneath mono-rail.)
11. Center the timber package over the car so that the operator is facing down the track.
12. Lower the load slightly and simultaneously release the brake.
13. As the load tips to place the center of gravity below the hinges, the lower part of the load will swing toward the operator. Check placement of load as the timber is continually lowered.
14. The lowest corner of the timber package will drop on the car and with additional lowering, the load will lie side down on the car.

15. Reposition the counterbalance approximately to where it was before loading.
16. Open the jaws, release the load slowly and turn the air off.
17. Raise the transfer clear of the timber package and back away.
18. If no additional packages are ready to be loaded, return the timber transfer to an out-of-the-way station.
19. Lower the inclined fore-frame until the toe of the pallet foot digs into the floor.
20. By backing up and additional lowering, the tipped grasping jaws can be righted and the brake applied.
21. Retire the machine to its original position until further need arises.

An experienced operator, confident of the machines capabilities, should be able to execute the preceeding instructions in a short time.

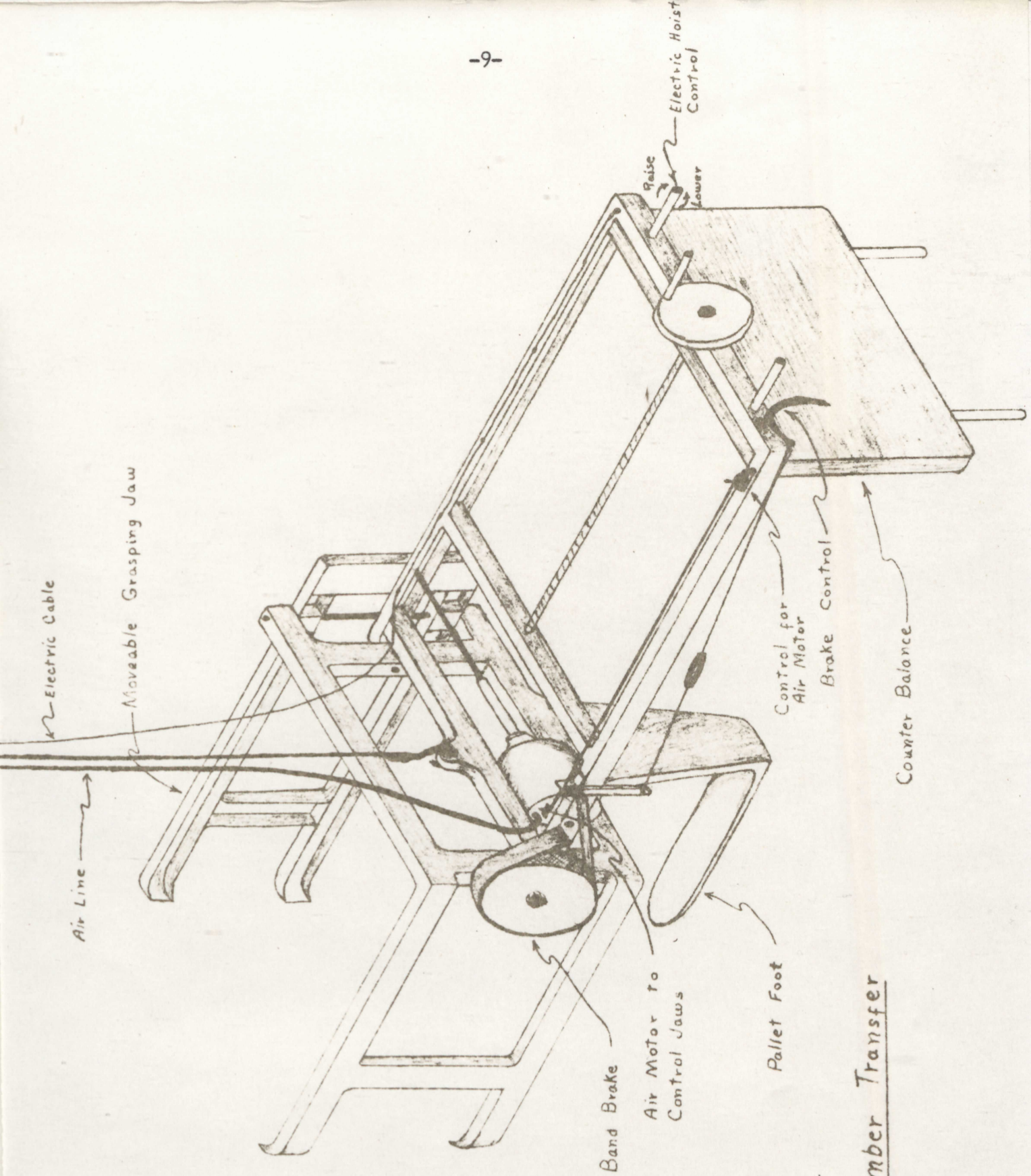

Mono-Rail Timber Transfer

Scale -  $\frac{3}{4}$ " = 1'

### Design Details

Many assumptions have been made in designing this piece of machinery. Mainly, ways and means have been devised to accomplish the desired job, instead of picking some particular commercial mechanism that could possibly do the same thing.

Possibly, junk yard scrap could be used to make a large portion of the timber transfer and by fabricating some unique controls (such as I have) from available spare parts original costs may be reduced.

Therefore, I do not maintain that my design is the only means of accomplishing the required end. I only advance a single possibility out of the multitude that must exist for performing each duty. Should certain manufactured units exist and be available for the fabrication, it is very likely an improved machine would result, but costs would also increase.

### Rear Frame

Stock channel iron 3 in. by 1.5 in. with the long dimension vertical, will be used to construct the frame. A total of five pieces, two long sides and three short cross pieces welded by the electric arc method would complete the frame. Undoubtedly, certain spots receiving great wear and spots under great strain must be reinforced by patch welding. I have not indicated these locations in my drawings because of the difficulty in maintaining a clear drawing.

The front cross piece bearing the hoist hook connection must be strengthened along with the side pieces connected to it.

The hinges, welded into the frame, must be of high strength.

### Fore Frame

The fore frame, also of welded construction, is built of the same channel iron as the rear but is more complicated in structure. Of the eleven pieces needed, 4 will form the jaws, 2 the cross pieces joining the jaws and the remaining 5 will be separators and braces. The frame near the jaw hinge and the moveable jaw itself, will require extensive reinforcement to resist failure. The plate, where the jaw pressure is applied by the power screw, must be faced with hardened alloy steel and reinforced to retain its smooth surface. Otherwise, the ball-bearing transmitting the pressure would rapidly penetrate and wear the surface.

### Counterbalance

A counterbalance is necessary to offset the weight of the timber package during transportation from shaft to timber car. Because the entire machine is supported on one cable, the transfer will always be balanced on both sides of the hoist hook. To obtain equilibrium, the heavy side always drops in relation to the high side. With a moveable counterbalance, proper positioning assures a level machine while variable weights are being transported in the jaws. The centroid of the jaw enclosure lies close to 1.5 feet in front of the hinge pins, while the counterweight can be moved 5.ft. to the rear of the hinges, producing an advantage pound for pound of nearly 3.5. The balance weighs 525 lbs. and should offset a 1750 lb. timber load when placed at the extreme rear. Empty, the weight will have to be moved all the way forward and should the rear portion still be heavy an uptilting of



the forward frame will help.

A high helix ( $45^{\circ}$ ) power screw will position the weight rapidly. The positioning crank is mounted  $\frac{1}{2}$  in. in on a 10 in. wheel giving a 9:1 mechanical advantage.

Bearings will be necessary where the weight slides on the frame, but selection of these bearings should not be critical.

#### Brake

The wheel secured to the left hinge pin must be surfaced with a woven asbestos lining possessing as high a coefficient of friction as possible. Because of the little use and slow motion, wear and heat will be of slight concern in this brake design. A flexible steel strap 2 in. wide and  $\frac{5}{32}$  in. thick will provide the matching friction surface for the asbestos lining. The moveable end of the strap is fastened to a 4:1 lever, manipulated through an adjustable cable by a squeeze lever adjacent to the left hand-grip. A slight mechanical advantage also exists in the hand lever. A turnbuckle is employed in the control cable to allow for brake adjustment. Two short pieces of angle iron back-to-back are welded on top of the rear frame section. The angle irons will support the upper pivot pin on the bank lever. Various arrangements can be produced to achieve these same results.

#### Grasping Jaws

The reversible air motor is rigidly mounted on the frame, as is the power screw, but the power screw is free to move in and out of the hole in the frame. This system exerts about 6000 lbs. pressure on the

rear extension of the grasping jaw, which produces only a 1000 lb. force at the tips of the forks.

Hinge springs, similar to those used to close screen doors must be mounted on the hinge pin where it passes through the moving jaw. Spring tension will always tend to open the jaws, As the air motor is reversed and the screw withdrawn, the jaws will gradually open to a maximum.

Parts consist of a  $\frac{1}{2}$  in. power screw inside a 1 in. shaft. The motor must produce 435 in.-lbs. of torque which on the 5° helix of the screw amounts to 6000 lbs. pressure.

A self assumed motor control has been devised to govern jaw movement. According to the operation cycle, the brake can be released at times when the motor must be turned on or reversed. Therefore, the control lever is left hand manipulated.

### Hoist

An electric hoist of two ton capacity is required to raise and lower the timber transfer.

The hoist problem is a matter of pure selection and not invention. Any commercial model conforming to the requirements should be satisfactory, but care must be exercised to select the best one from performance standpoint.

The control buttons must be inset into the frame so the right hand grip can control vertical movement.

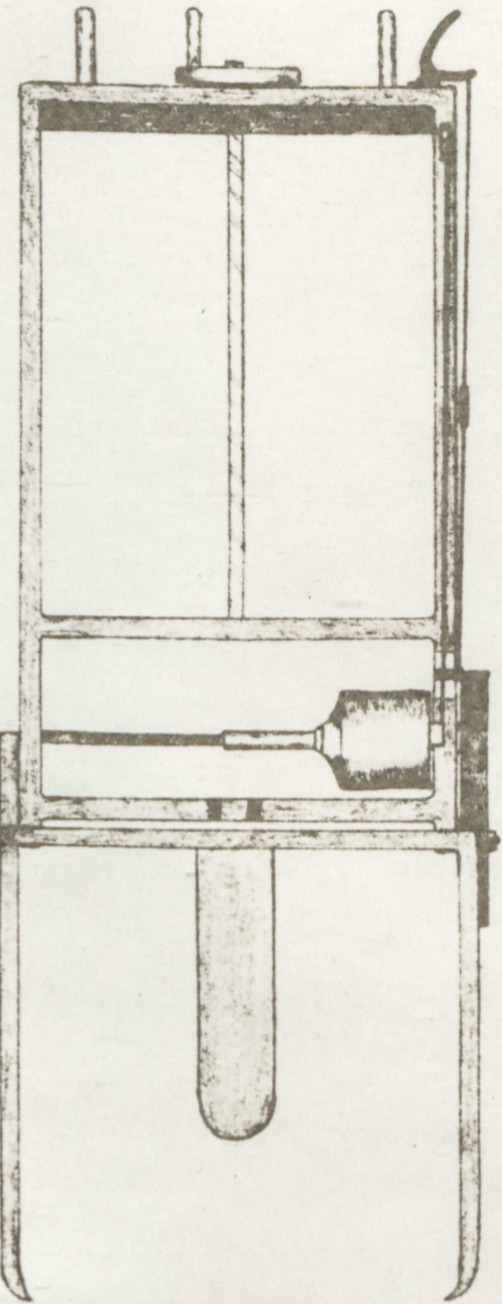

Top View

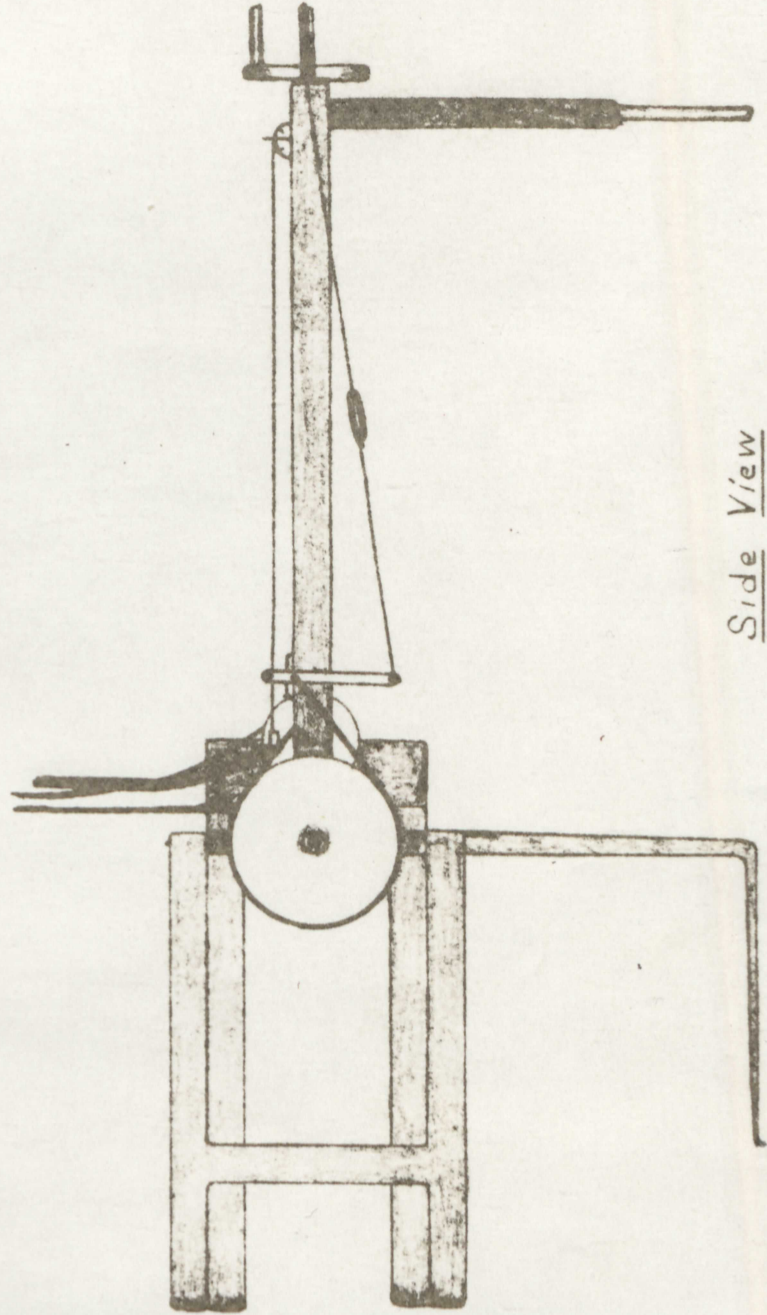

Side View

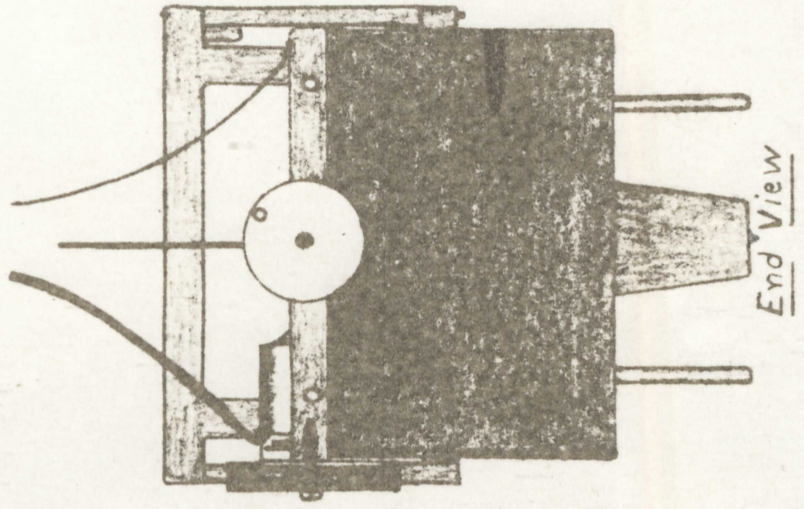

End View

Mono-Rail Timber Transfer

Scale - 3/4" = 1'

Calculations

Rear Frame

Calculation for bending stress on 3 x 1.5 channel.

$$S_b = \frac{M}{\frac{I}{c}} = \frac{518\cancel{\#} / 36\cancel{\#} \times 60 \text{ in.}}{1.1 \text{ in.}^3} = 15,100 \text{ psi max.}$$

N. Y. builders code for structural members allows for 18,000 psi. Therefore, selected size is O.K.

Frame consumes 19 ft. of channel @ 4.1 lbs. per ft. = 78.0 lbs.

Front Frame

Use same channel iron except for pallet foot which is weld fabricated from sheet metal.

Weight	4-3 ft. grasping arms	= 12 ft.	
	2-3 ft. cross pieces	= 6 ft.	
	6-1.5 ft. vertical pieces	= 9 ft.	
	Total	27 ft. x 4.1	= 111.0 lbs.

(Pallet foot)	$\frac{30 \cancel{4} 15}{2} \times 2$	= 45 lbs. vert. support	
	15 x 2	= 30 lbs. horiz. foot	
		75 lbs.	
		$\cancel{4}$ 10 lbs. weld	
		85 lbs.	85.0 lbs.

Counterbalance

Made of wrought iron - 480 lb./ft.<sup>3</sup>

2 in. thick, 35.5 in. wide, 26.5 in. high = 1880 cu. in.

$$\frac{1880}{1728} \times 480 = 525 \text{ lbs.} \quad 525.0 \text{ lbs.}$$

Power Screw for Counterweight

Use a 45° helix screw, 1 in. in diam., on a 10 in. wheel.

$$\frac{4.5}{.5} = \text{M.A. of } 9:1$$

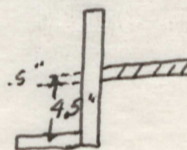

Controls

Handles

Select 1 in. pipe, 6 in. long. If desired, rubber handle grips could be cemented over pipe. Three of these handles are required.

Air Motor

Any three position switch that can control air valves inside the motor is adequate. My idea is enlarged below. Only a small tension exists on the control cable.

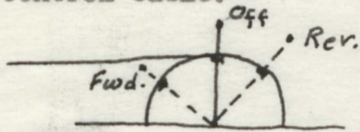

Brake

A strong curved handle similar to a hand brake lever on a bicycle should serve splendidly. A stout cable is needed to withstand the tension. Any small turnbuckle will suffice.

Main Hinge Pin (frame)

Use 2 pins with a shear S.F. = 4

Use SAE 1095 -- oil quenched with  $S_s = 40,000$  psi

$$d^2 = \frac{2 F}{3.14 S_s} = \frac{2 \times 7000}{3.14 \times 40,000} = .0318 \text{ in.}^2$$

$d = .18 \text{ in.} \times 2 \text{ (S.F.)} = .36 \text{ in.}$  Be on safe side  
use  $\frac{1}{2}$  in. pins.

Grasping Hinges (Same material as above)

Use one straight pin through both hinges

Shear S.F. = 4.,  $S_s = 40,000$  psi

$$d^2 = \frac{2 F}{3.14 S_s} = \frac{12,000}{3.14 \times 40,000} = \frac{.3}{3.14} = .0955$$

$d = .31 \times 2 \text{ (S.F.)} = .62$  -- use  $\frac{5}{8}$  in. pins.

Brake

$r = 6 \text{ in. (drum)}$        $a = 2 \text{ in.}$   
 $\theta = 5 \text{ rad.}$        $b = 8 \text{ in.}$   
 $f = .6 \text{ (woven lining)}$   
 $e = 2.718$   
 $T = 38,400 \text{ in. lbs. (2130 lbs. x 18 in.)}$

$F_1: F_2$  ratio

$$\frac{F_1}{F_2} = e^{f\theta} = 2.718^3 = 20$$

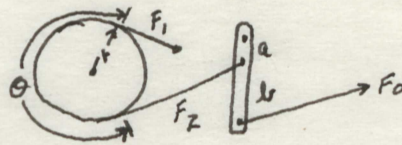

$$F_1 = 20 F_2$$

$$T = (20 F_2 - F_2) r$$

$$19 F_2 = \frac{36400}{6}$$

$$F_2 = 342 \text{ lbs. - assume } 350 \text{ lbs.}$$

$$F_0 = \frac{a}{a+b} F_2$$

$$= \frac{1}{5} F_2 = 70 \text{ lbs.}$$

Air Motor

Assume 1000 lbs. needed at fork tips, but will be distributed over 2 - 3 ft. arms. Helix angle =  $5^\circ$ .  
 Because of mechanical advantage of  $1/6$ ,  $P_a = 6000 \text{ lbs.}$

$$T = \frac{F_a P}{2 \times 3.14 e}$$

$$e = .60$$

$$p = \frac{3.14}{2} \sin 5^\circ = .137$$

$$T = \frac{6000 \times .137}{2 \times 3.14 \times .60}$$

$$T = 435 \text{ in. lbs. required motor torque}$$

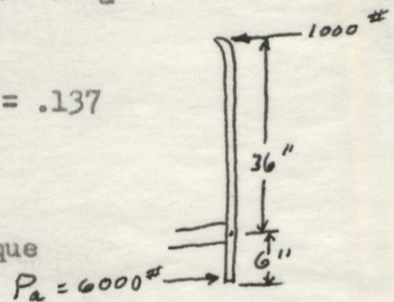

Total Weight

<u>Unit</u>	<u>Weight</u>
Power Screws .....	----
Control apparatus.....	----
Hinge pins.....	----
Brake.....	----
Air Motor.....	----
For these parts assume	<u>75 lbs. total</u>
Rear Frame	78 lbs.
Front Frame	196 lbs.
Counterbalance	525 lbs.
Timber load	<u>2100 lbs. (max.)</u>
	2974 lbs. assume <u>3000 lbs.</u> or 1.5 tons

Hoist Cable

A 6-19 cable of plow steel, 5/16 in. in diam. breaks at 3.9 tons.

This gives a good 2.6 S.F. I would not choose a manufacturers product with a smaller cable than the one above.