

Prediction of Solar Radiation Intensity for Cost-Effective PV Sizing and Intelligent Energy Buildings

Eleni Kaplani and Socrates Kaplanis
Technological Educational Institute of Patras
 Greece

1. Introduction

The solar radiation in the form of electromagnetic waves emitted by the sun, travels the extraterrestrial space without any essential interaction with matter, and reaches the earth's atmosphere. Therein, the beam solar radiation undergoes physic-chemical processes and experiences scattering by (macro) molecules, dust, or other tiny particles in the air. This process creates the solar radiation component called diffuse radiation. Thus, the solar radiation on any surface on the earth consists of the beam solar radiation, the diffuse radiation and the one reflected by the surroundings.

On the other hand, the length of the path of the solar beam till it reaches the horizontal surface differs both during the day and during the year. It is high during morning and sunset hours and shorter during noon hours. Also, due to the sun's altitude which is low, i.e. closer to the horizontal in winter months for the North Hemisphere, the length of the path of the solar beam is longer and, therefore, the intensity of the solar radiation is essentially affected by the higher air mass it penetrates both on a daily and seasonally basis. Hence, solar radiation finally reaches the earth surface substantially decreased and dissipated compared to the extraterrestrial values. Table 1 and Figure 1 show the extraterrestrial solar

cities	φ	JAN	FEB	MAR	APR	MAY	JUN	JUL	AUG	SEP	OCT	NOV
Cairo	30.05	5.863	7.201	8.843	10.265	11.158	11.460	11.261	10.536	9.316	7.681	6.187
Iraklio	35.32	5.029	6.465	8.307	10.000	11.152	11.582	11.320	10.376	8.889	7.015	5.383
Athens	37.97	4.690	6.158	8.076	9.874	11.130	11.614	11.325	10.292	8.699	6.734	5.054
Thessaloniki	40.52	4.178	5.687	7.708	9.663	11.078	11.642	11.314	10.146	8.395	6.299	4.554
Firenze	43.78	3.664	5.204	7.321	9.429	11.003	11.648	11.281	9.976	8.067	5.848	4.050
Zagreb	45.80	3.322	4.876	7.051	9.259	10.941	11.645	11.248	9.850	7.837	5.540	3.712
Paris	48.87	2.811	4.377	6.631	8.986	10.832	11.624	11.184	9.642	7.474	5.066	3.204
London	51.50	2.309	3.870	6.192	8.691	10.704	11.588	11.104	9.413	7.090	4.581	2.700
Hamburg	53.55	1.980	3.530	5.890	8.484	10.611	11.561	11.045	9.250	6.824	4.252	2.367
Copenhagen	55.72	1.659	3.190	5.581	8.266	10.513	11.531	10.982	9.080	6.549	3.920	2.039
Stockholm	59.35	1.049	2.508	4.943	7.810	10.307	11.479	10.852	8.719	5.977	3.247	1.403
Helsinki	60.22	0.905	2.339	4.780	7.692	10.255	11.470	10.821	8.625	5.829	3.077	1.251

Table 1. Average top-of-atmosphere insolation incident (kWh/m^2) for major cities with latitude spanning from 30° to 60° .

radiation data for various latitudes. Calculations and analysis was performed on the daily average solar radiation on top-of-atmosphere data obtained from NASA's online database (NASA Surface meteorology and Solar Energy, 2011). It is evident for the North Hemisphere that, as the latitude increases the top-of-atmosphere solar radiation decreases especially during the winter months, while during Summer the differences are very small. This is due to the position of the earth with respect to the sun.

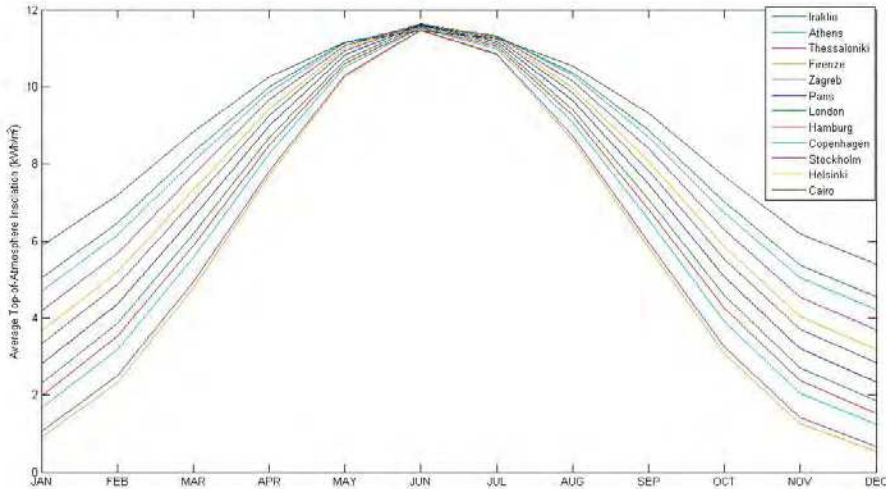

Fig. 1. Average top-of-atmosphere insolation incident (kWh/m^2) for major cities with latitude spanning from 30° to 60° .

The intensity of the solar radiation which reaches the earth outside its atmosphere in hour h in a day n_j is the extraterrestrial radiation, represented by $I_{\text{ext}}(h;n_j)$, and can be accurately estimated by the following equation.

$$I_{\text{ext}}(h;n_j) = I_{\text{sc}} \cdot \left[1 + 0.033 \cdot \cos\left(\frac{360 \cdot n_j}{365}\right) \right] \cdot [\cos(\varphi)\cos(\delta)\cos(\omega_s) + \sin(\delta)] \quad (1)$$

where, I_{sc} is the solar constant, about $1365 \text{ W}/\text{m}^2$, and n_j is the incremental number of the day, with a value range $[1, 365]$, where 1 corresponds to the 1st of January and 365 to the 31st of December. ω_s is the sunset hour angle, φ is the latitude of the site and δ is the angle of declination of the sun. The daily extraterrestrial solar radiation is determined by eq.(2) (Duffie & Beckman, 1991).

$$\begin{aligned} H_{\text{ext}}(n_j) &= \int I_{\text{ext}}(h;n_j) dh = \\ &= \frac{24 \cdot 3600}{\pi} I_{\text{sc}} \left[1 + 0.033 \cos\left(\frac{360 n_j}{365}\right) \right] \cdot \left[\cos(\varphi)\cos(\delta)\cos(\omega_s) + \frac{\pi \omega_s}{180} \sin(\varphi)\sin(\delta) \right] \end{aligned} \quad (2)$$

where, ω_s is expressed in degrees. If ω_s is in radians, then the factor $\pi/180$ should be omitted. The angle ω_s is determined by the following equation.

$$\omega_s = \cos^{-1}(-\tan(\varphi)\tan(\delta)) \quad (3)$$

Thus, the extraterrestrial solar radiation can be accurately estimated. However, the local weather conditions characterized by the Atmospheric Pressure, P_a , the Ambient Temperature, T_a , the wind velocity, v_w , the relative humidity, RH, and the cloudiness associated to the Clearness Index, K_T , (Collares-Pereira & Rabl, 1979; Kaplanis et al., 2002), may change hour by hour stochastically. Thus, the solar radiation on the horizontal of the earth's surface cannot be accurately pre-determined. All this implies that the solar radiation in a day at a place may not be the same for the same day the year after, as the weather conditions may not be the same for those two days, see for example Figure 2, where it is evident that for the same day in consecutive years the pattern differs, while the insolation in the top-of-atmosphere is always the same.

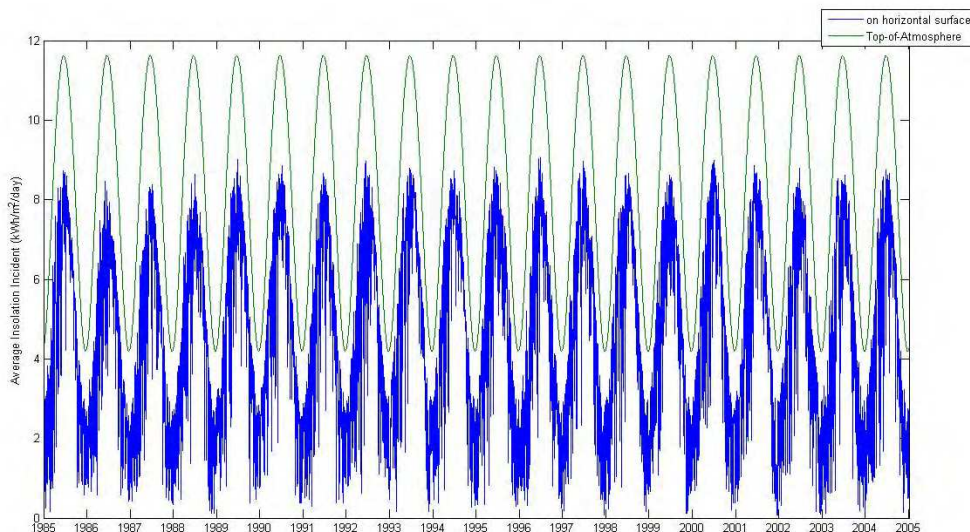

Fig. 2. Average insolation incident on horizontal and on top-of-atmosphere per day for the years 1985-2004 in Athens, Greece.

2. Solar radiation data analysis and the in-built stochastic nature

A large amount of solar radiation data is stored and provided by national databases from local meteorological stations, such as HNMS's (Hellenic National Meteorological Service, 2011), and global databases such as NASA's (NASA Surface meteorology and Solar Energy, 2011), JRC's PVGIS (Photovoltaic Geographical Information System, 2008), SoDa (Solar Radiation Data, 2011), etc. Thus previous years' data for a site of interest may be retrieved and analysed in order to serve as an appropriate input to PV sizing or other applications.

As previously discussed, the solar radiation data exhibit a dispersion, larger or smaller depending on the latitude and the microclimate of the site. Figures 3 and 4 show the fluctuations of the daily solar radiation on the horizontal as it appears around the representative day of each month for the years 1985-2004 for the city of Athens, Greece and

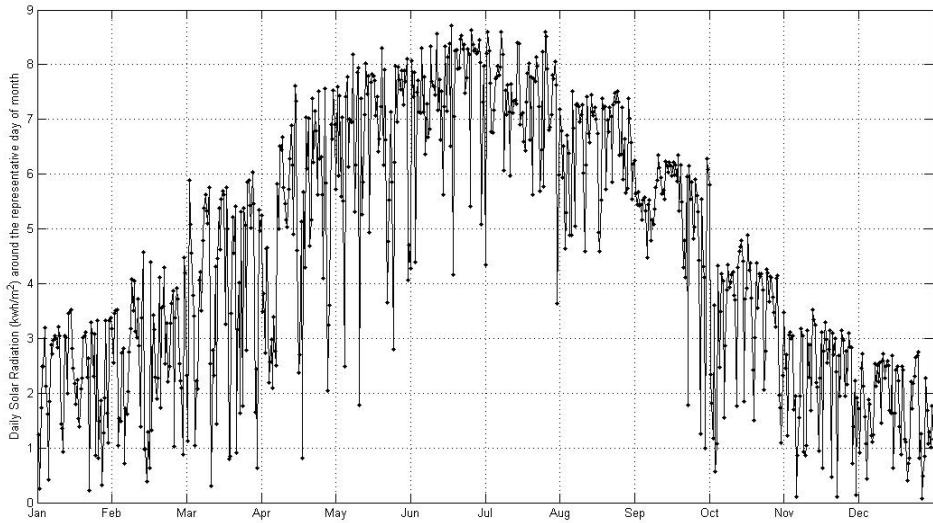

Fig. 3. Daily solar radiation (kWh/m²) around the representative day of each month for the 20 year period (1985-2004), in the city of Athens, Greece.

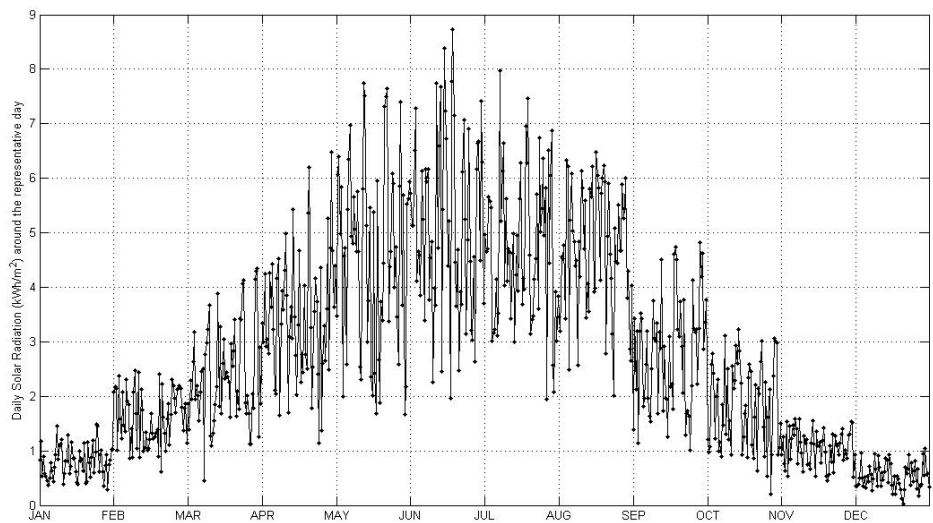

Fig. 4. Daily solar radiation (kWh/m²) around the representative day of each month for the 20 year period (1985-2004), in the city of London, UK.

the city of London, UK, respectively. Calculations and analysis was performed on the daily global solar radiation data obtained from NASA’s online database (NASA Surface meteorology and Solar Energy, 2011). It is obvious that the profile of the solar radiation and the degree of the inherent solar radiation stochastic fluctuations in the two cities differ substantially. Figure 5 shows the average global solar radiation on horizontal per month for the same years and for major cities with latitude spanning from 30° to 60°.

As the daily solar radiation exhibits different degree of fluctuations both during the day and throughout the year on different sites, it is important that the past years data available for the site of interest are thoroughly analysed before a solar radiation prediction methodology or PV sizing methodology is employed.

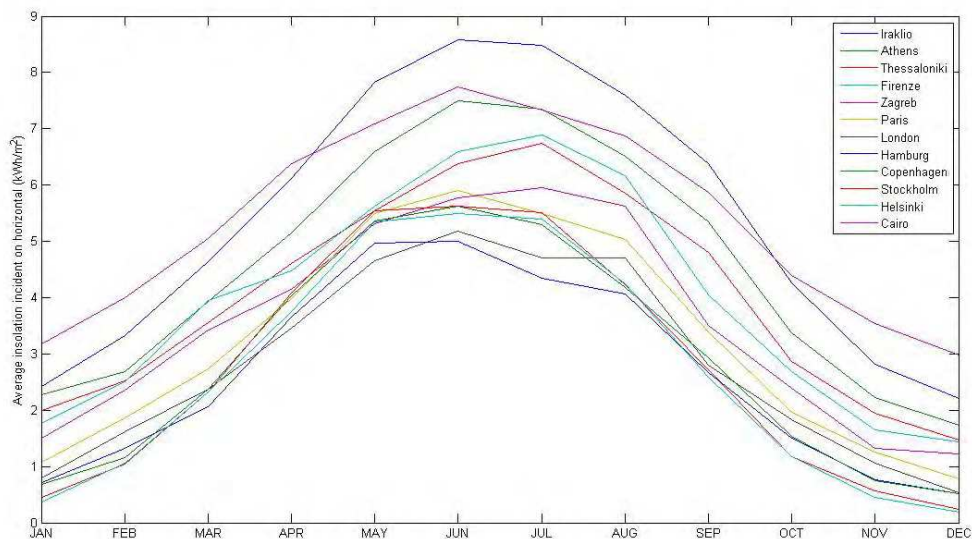

Fig. 5. Average solar radiation around the representative day of each month for the 20 year period (1985-2004), for major cities with latitude from 30° to 60°.

An in-depth analysis of past years data for the site of interest may be carried out to provide the probability density function (pdf) the data obey. Research studies have reported on the use of the Gaussian distribution or modified Gaussian (Jain et al. 1988), the Weibull distribution (Balouktsis et al., 2006), and the Extreme Value (Type I) distribution (Kaplani & Kaplanis, 2011). However, due to the inherent stochastic character of the solar radiation fluctuations, the differences in the location of the various sites, and the differences in the databases used, an argument upon the preference of one pdf over the other is avoided. Instead, the designer may analyse the data of the site of interest, extract the pdfs and assess the best fit provided by the various distributions. The proposed pdfs of the Normal, Weibull, and Extreme Value (Type I) distribution are given by eqs. (4) to (6), respectively.

$$f(x; \mu, \sigma) = \frac{1}{\sigma\sqrt{2\pi}} e^{-\frac{(x-\mu)^2}{2\sigma^2}} \quad (4)$$

$$f(x; a, b) = ba^{-b}x^{b-1}e^{-\left(\frac{x}{a}\right)^b}, \quad x \geq 0 \quad (5)$$

$$f(x; \mu, \sigma) = \sigma^{-1} \cdot e^{\left(\frac{x-\mu}{\sigma}\right)} \cdot e^{-e^{\left(\frac{x-\mu}{\sigma}\right)}} \quad (6)$$

An example of the fitting of the 3 distributions on the pdf of January's data for Athens, Greece is provided in Figure 6. It is obvious that the Extreme Value distribution in this case provides a more accurate fit on the data.

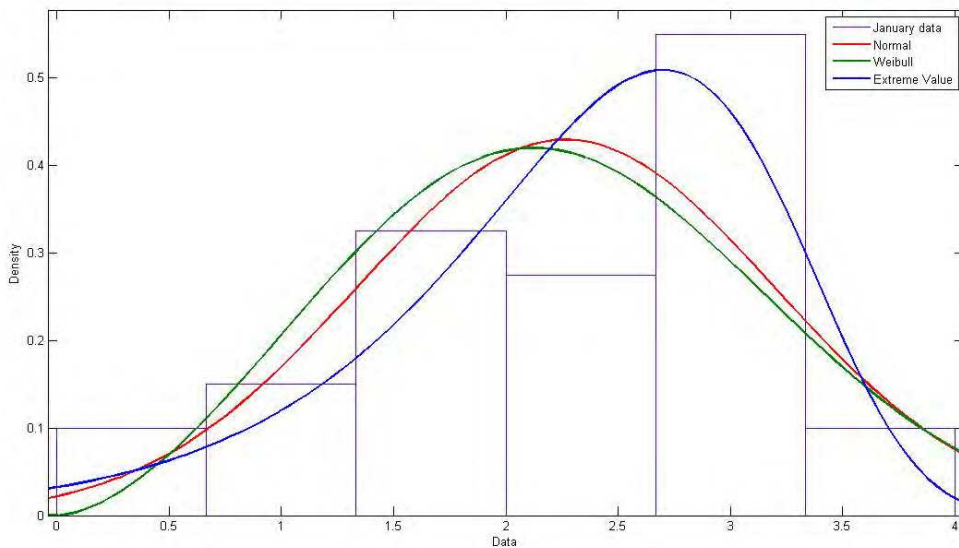

Fig. 6. Normal, Weibull, and Gaussian distributions fitted on the pdf of January's data for Athens, Greece, drawn around the representative day for the period 1985-2004.

Using the maximum Likelihood criterion for assessing the best fitted distribution, the Extreme Value distribution proved to best fit the data for all months (Kaplanis & Kaplanis, 2011). A more detailed statistical analysis may be performed, using the Kolmogorov-Smirnov test in order to test the null hypothesis that the data come from a specified Normal distribution, or the Lilliefors test to test the null hypothesis that the data come from a Normal or an Extreme Value distribution, etc. It is recommended that a large sample of data is used for the fitting.

3. Hourly and daily solar radiation prediction

Having performed an in-depth statistical analysis on the past years data, it may be said that future daily solar radiation data may be anticipated to fall within the specific distribution which best fitted the previous years' monthly data. However, several solar radiation prediction models have been proposed in the literature some of which may be more globally applied.

Kaplanis in (Kaplanis, 2006) has proposed the model provided by eq.(7) to estimate the daily solar radiation for any day n_j . Parameters A, B, C are estimated by fitting an equation of this form on average monthly past years' data. An example of the fitting produced by this equation on monthly average data for Athens and Stockholm are displayed in Figures 7, 8. Table 2 shows the estimated A, B, C parameters for different cities and the correlation coefficient r showing the goodness of fit of eq.(7) on the data. Parameters A and B follow a function with argument ϕ , as it is evident from the profile of the data in Table 2.

$$H(n_j) = A + B \cdot \cos(2\pi n_j/365 + C) \tag{7}$$

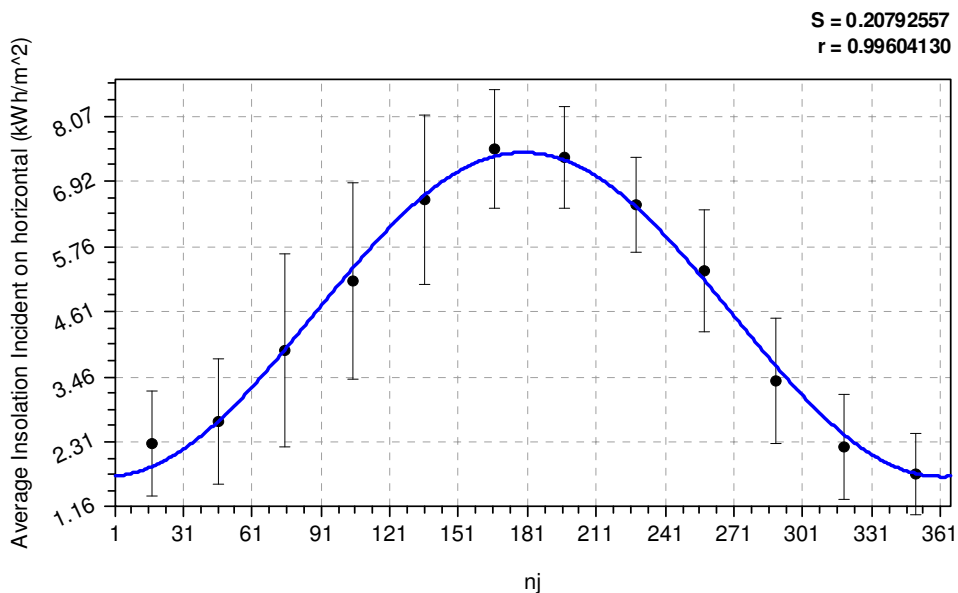

Fig. 7. Fitting results of eq.(7) on monthly data for Athens (period 1985-2004)

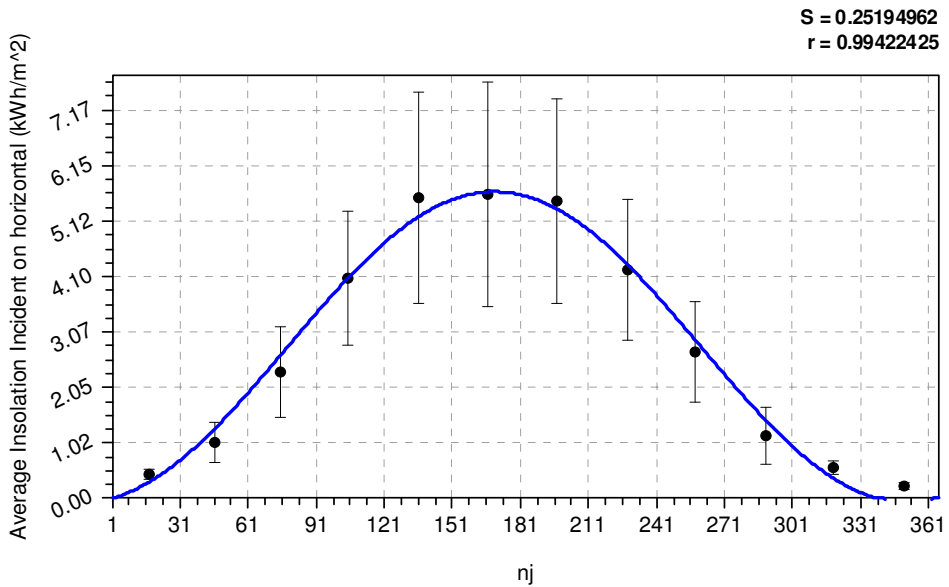

Fig. 8. Fitting results of eq.(7) on monthly data for Stockholm (period 1985-2004)

city	A	B	C	r
Iraklio	5.39	3.26	3.18	0.999
Athens	4.56	2.86	3.21	0.996
Thessaloniki	3.92	2.71	3.19	0.976
Paris	3.20	2.66	3.29	0.992
London	2.77	2.35	-3.01	0.990
Stockholm	2.79	2.87	-2.90	0.995

Table 2. Estimated parameters A, B, C for the various cities

Hourly based prediction models, based on similar functions, have also been proposed such as the model proposed by Kaplanis in eq.(8) (Kaplanis, 2006), where $a(n_j)$ and $b(n_j)$ are estimated through 2 boundary conditions and depend on the site and day n_j . The model proposed by the authors in eq.(9) (Kaplanis & Kaplani, 2007) proved to give much better results compared to other known models.

$$I(h; n_j) = a(n_j) + b(n_j) \cdot \cos(2\pi h/24) \tag{8}$$

$$I(h; n_j) = A + B \frac{e^{-\mu(n_j)x(h)} \cdot \cos(2\pi h/24)}{e^{-\mu(n_j)x(h=12)}} \tag{9}$$

Figure 9, shows an example of the hourly predicted curve obtained by this model using eq. (9) for the 17th January and the city of Patras, Greece. The past years hourly data and average data for the same day are also displayed for comparison. The national database (Hellenic National Meteorological Service, 2011) was used for the hourly solar radiation data for Patras, Greece for the period 1995-2000. For the summer data, where smaller hourly fluctuations occur, the proposed model gives even better results, see Figure 10.

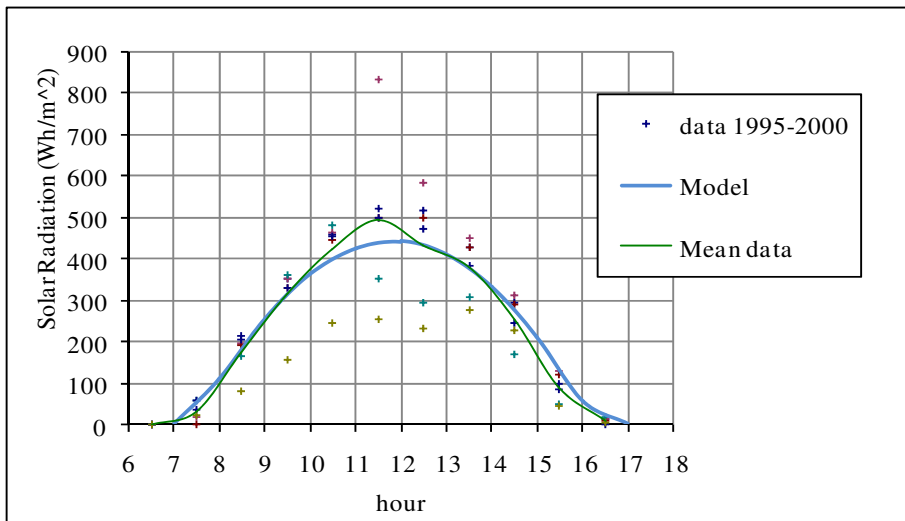

Fig. 9. Hourly data for January 17, for the city of Patras, Greece, and the hourly prediction model.

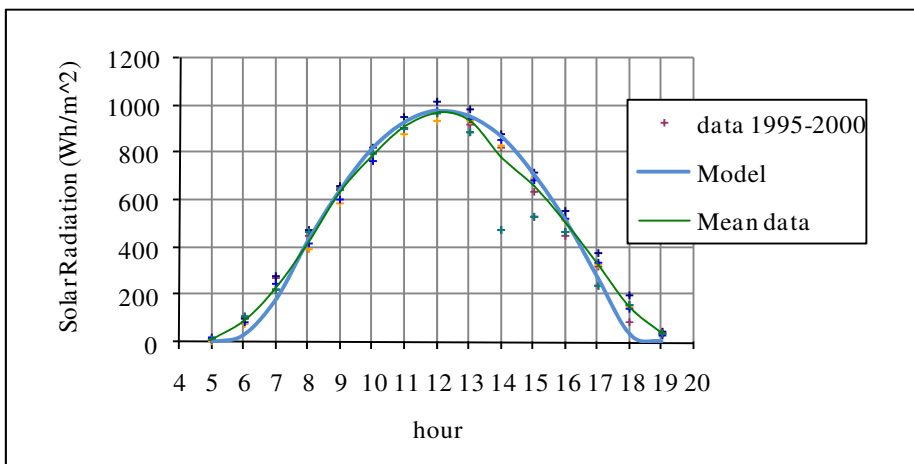

Fig. 10. Hourly data for July 17, for the city of Patras, Greece, and the hourly prediction model.

Several research studies have been published on various aspects in the modeling of solar radiation dealing with mean and stochastic values. For a global perspective the reader is advised to see also (Aguiar et al., 1988; Aguiar & Collares-Pereira, 1992; Festa et al., 1992; Gueymard, 1993; Gueymard, 2000; Jain et al., 1988).

The hourly solar intensity provided by eq.(9), denoted by the authors as mean predicted value $I_{m,pr}$, or mean expected $I_{m,exp}$, is used in a more dynamic stochastic model which uses one morning measurement as an input and based on the statistical difference of this measurement from the mean predicted and the assumption of a Gaussian profile, predicts the hourly solar radiation values for the remaining hours of the day (Kaplanis & Kaplani, 2007). This is a very challenging attempt considering that the model predicts a dynamic hourly profile depending on only one early morning measurement. The authors improved that model to take into account either 1, or 2, or 3 morning measurements, predicting the hourly solar radiation profile for the remaining hours of the day with increased accuracy (Kaplanis & Kaplani, 2010). In case that a rich database of past years data exist, it is proposed also the use of average hourly data instead of the mean expected. Thus, according to this model, the prediction of the solar radiation at hour h in a day n_j is based on the following expression.

$$I_{pr}(h;n_j) = I_{av}(h;n_j) + R \cdot \sigma_{I(h;n_j)} \quad (10)$$

where R is a random number drawn from a Gaussian distribution ($\mu=0, \sigma=1$), however, it is confined within the interval $[t_1 \pm 1]$, where t_1 is determined for the previous hour h_1 by eq.(11). For the estimation of t_1 it is assumed that the difference between the one morning measured value $I_{meas}(h_1;n_j)$ value at hour h_1 from the average $I_{av}(h_1;n_j)$ value at the same hour h_1 from the past years' data, follows a Gaussian probability density function. For the predicted value $I_{pr}(h;n_j)$ only positive values, values less than the extraterrestrial $I_{ext}(h;n_j)$, and less than $I_{av}(h;n_j) + 3\sigma_{I(h;n_j)}$ are accepted, which is necessary to cut off the Gaussian tail for high values above the average.

$$t_1 = \frac{I_{meas}(h_1;n_j) - I_{av}(h_1;n_j)}{\sigma_{I(h_1;n_j)}} \quad (11)$$

For the hourly solar radiation prediction profile based on two morning measurements at hours h_1 and h_2 , eq.(12) is proposed, which now uses two stochastic terms, one term as in eq.(10), which stands for the stochastic fluctuations at hour h_3 , and a second term to stand for the rate of change of the $I(h;n_j)$, within the time interval $[h_1, h_2]$. t_2 is determined here similarly to t_1 in eq.(11) but now for hour h_2 .

$$I_{pr}(h_3;n_j) = I_{av}(h_3;n_j) + R \cdot \sigma_{I(h_3;n_j)} + \frac{1}{4} \cdot (t_2 \cdot \sigma_{I(h_2;n_j)} - t_1 \cdot \sigma_{I(h_1;n_j)}) \cdot R_1 \quad (12)$$

The hourly solar radiation prediction based on three morning measurements at hours h_1, h_2, h_3 is given by eq.(13), where the use of an extra stochastic term is proposed, which provides the contribution of the second derivative of $[I_{meas}(h;n_j) - I_{av}(h;n_j)]$, with respect to h , to the $I(h;n_j)$ prediction.

$$\begin{aligned}
 I_{pr}(h_4;n_j) = & I_{av}(h_4;n_j) + R \cdot \sigma_{I(h_4;n_j)} + \frac{1}{4} \cdot (t_3 \cdot \sigma_{I(h_3;n_j)} - t_2 \cdot \sigma_{I(h_2;n_j)}) \cdot R1 + \\
 & + \frac{1}{9} \cdot (t_3 \cdot \sigma_{I(h_3;n_j)} - 2 \cdot t_2 \cdot \sigma_{I(h_2;n_j)} + t_1 \cdot \sigma_{I(h_1;n_j)}) \cdot R2
 \end{aligned}
 \tag{13}$$

The model continues to predict the solar radiation at next hour based on the predicted values for the previous hours. For more details on this hourly solar radiation predictive model see (Kaplani & Kaplani, 2010). Figures 11, 12 show the predicted hourly profile by this dynamic model using a national database for the city of Patras, Greece and the period 1995-2000 (Hellenic National Meteorological Service, 2011). By entering one, two or three morning measurements, the model predicts the hourly solar radiation profile for the remaining hours of the day. It is evident from the figures that the model based on the three morning measurements gives the best results and a prediction very close to the true measured data, even for these cases where the true data lie far away from the average years' data. Due to the random factors that appear in the eqs.(10), (12), (13), the generated hourly predicted profile is never exactly the same but fluctuates stochastically within a small range of values.

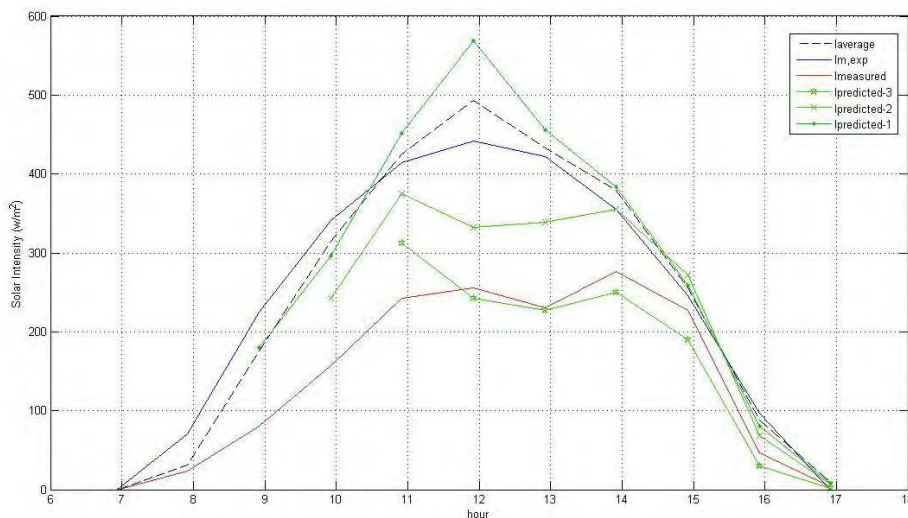

Fig. 11. Hourly predicted profiles based on one (Ipredicted-1), two (Ipredicted-2) and three (Ipredicted-3) morning measurements. Plotted against the average data profile (Iaverage), the mean expected (Im,exp) calculated by eq.(9), and the true measured data (Imeasured) on 17th January 2000, in Patras, Greece.

Other research studies have proposed methodologies for prediction of sets of hourly profiles based on Neural Networks (Kalogirou, 2000), Markov chains (Aguiar et al., 1988) and Fuzzy Logic (Iqdour & Zeroual, 2007).

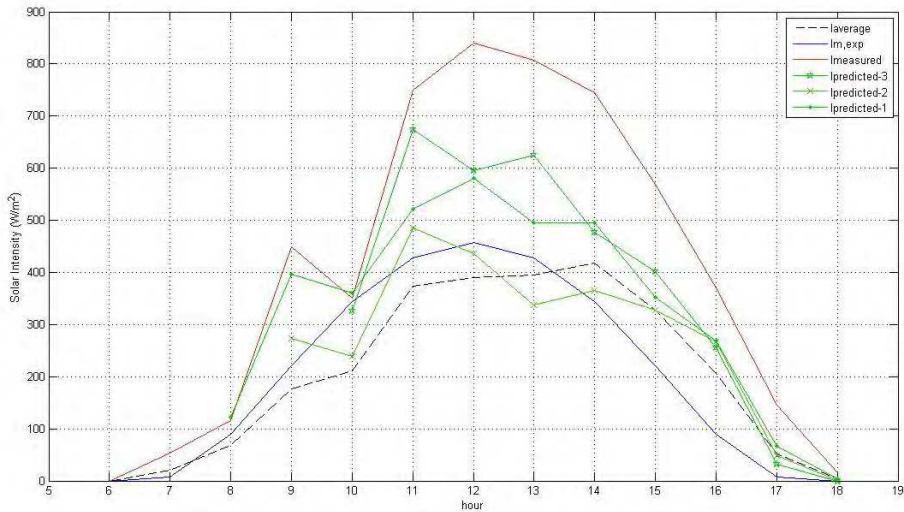

Fig. 12. Hourly predicted profiles based on one ($I_{\text{predicted-1}}$), two ($I_{\text{predicted-2}}$) and three ($I_{\text{predicted-3}}$) morning measurements. Plotted against the average data profile (I_{average}), the mean expected ($I_{\text{m,exp}}$) calculated by eq.(9), and the true measured data (I_{measured}) on 16th March 1995, in Patras, Greece.

4. PV sizing methodologies

The previous sections have dealt with the analysis of the in-built stochastic nature of solar radiation data and the challenging issue of predicting daily and hourly solar radiation profiles with a high level of reliability. This would be most useful in problems dealing with the effective and reliable sizing of solar power systems, PV generators, and the predictive management of a complete system of solar energy sources in conjunction with the power demand by the loads, since the output of PV systems is highly affected by stochastic meteorological conditions.

Apart from the requirement for maximizing the Yield Y_f (kWh/kWp) for a PV plant on an annual basis, there is also an increased concern about the reliability of the PV performance, i.e. to meet the loads with a pre-determined confidence level, at the minimum possible installed Peak power. The design of a PV plant should aim at installing a plant able enough to produce and deliver the right output at the minimum cost, with a small Pay-Back Period (PBP) and a high Performance Ratio (PR), (RETScreen, 2011).

In any PV sizing task all potential power losses related to the PV system elements, i.e. the inverter, charger, battery storage system, cables, etc. and effects due to PV cell ageing, battery ageing, matching effects, shadowing, etc., need to be thoroughly investigated and analysed in order to reach the required Peak Power to be installed. Furthermore, a statistical analysis of the daily solar radiation and hourly solar radiation fluctuations is essential within the scope of the PV sizing, as the inherent statistical fluctuation lead to an uncertainty with respect to the installed Peak Power, a major consideration when a reliable Stand-Alone PV system (SAPV) is to be installed. The issue of reliability has driven sizing

methodologies to the introduction of the concept of energy autonomy period of a PV plant, expressed using the autonomy factor d . The autonomy factor d was introduced for critical and non-critical loads, given by eqs. (14) and (15) respectively, to provide energy autonomy when using non-critical loads, requiring power at least 95% of the time, and when using critical loads, requiring power at least 99% of the time (Messenger & Ventre, 2000).

$$d_{cr} = -1.9 \cdot PSH_{min} + 18.3 \quad (14)$$

$$d_{n-cr} = -0.48 \cdot PSH_{min} + 4.58 \quad (15)$$

where PSH is the Peak Solar Hour, defined and estimated as in (Messenger & Ventre, 2000) for any day, and PSH_{min} is its minimum value. It is evident that the smaller the minimum PSH value, as derived from the past years solar radiation data for a region, the higher the value of d . The drawback of the conventional sizing approach is its high cost, as both the Peak power (P_m) to be installed, given by eq.(16), and the Capacity of the Battery Storage System (C_L), given by eq.(17), increase linearly with the value of d for energy autonomy.

$$P_m = \frac{d \cdot Q_L \cdot F}{PSH_m \cdot R_m} \quad (16)$$

$$C_L = \frac{d \cdot Q_L \cdot F'}{V \cdot DOD} \quad (17)$$

where Q_L is the daily load (Wh), F and F' are correction factors due to transfer power losses, V is the transfer voltage and DOD the depth of discharge of the battery. The mean PSH is denoted by PSH_m , and R_m is used for the conversion of the solar intensity from the horizontal to the PV array inclined plane, see (Duffie & Beckman, 1991; RETScreen, 2001). R depends on the day of the month, the latitude of the place and the microclimate of the region.

This conventional PV sizing methodology gives reliable results providing energy autonomy to the system through the use of the autonomy factor d in the estimation of P_m and C_L , considering the statistical properties of the solar radiation data as introduced through PSH_{min} . However, with the increase of d to accommodate fluctuations in the solar radiation data, the estimated P_m and C_L to be installed increase substantially, leading to a requirement for a larger PV array and a larger battery storage system.

A more cost-effective approach has been proposed in (Kaplanis & Kaplani, 2006), whereby a different approach to the estimation of the autonomy factor is used, leading to a reliable system with the need for lower installed P_m and C_L . In this approach it is assumed that $H(n_j)$ values follow a Gaussian probability density function, and, thus, the expected $H(n_j)$ value will lie with a 95% confidence level, in the domain:

$$H(n_j) \in \left[H_m(n_j) \pm 2 \cdot \sigma_{H(n_j)} \right] \quad (18)$$

where $H_m(n_j)$ is the mean daily solar radiation on the horizontal for the representative day of the month, for which the PV plant is to be sized, through a period of N years and $\sigma_{H(n_j)}$ is the standard deviation of $H(n_j)$.

According to this model if the system is to be sized to guarantee a number of d days of system autonomy to accommodate any possible solar radiation fluctuation, the total uncertainty introduced in the determination of P_m through the estimation of PSH, whose

value (h/day) is numerically equal to the value of $H(n_j)$ measured in kWh/m², would be given by the following expressions.

$$\sigma_{H_d}^2 = \sigma_{H(n_j)_1}^2 + \sigma_{H(n_j)_2}^2 + \dots + \sigma_{H(n_j)_d}^2 \approx d \cdot \sigma_{H(n_j)}^2 \quad (19)$$

$$\sigma_{H_d} = \sqrt{d} \cdot \sigma_{H(n_j)} \quad (20)$$

The relative change in the P_m to accommodate an energy deficit for d days with a confidence level of 95%, may be given by eq.(21). Thus, a correction factor is introduced in the determination of P_m , provided by eq.(22). This correction factor is also included in the determination of C_L , see eq.(23).

$$\frac{\delta P_m}{P_m} = \frac{\delta(P_{SH})}{P_{SH_m}} = \frac{\sigma_{H_d}}{H_m(n_j)} = \frac{2 \cdot \sqrt{d} \cdot \sigma_{H(n_j)}}{H_m(n_j)} \quad (21)$$

$$P_{m,d} = P_m \cdot \left(1 + \frac{2 \cdot \sqrt{d} \cdot \sigma_{H(n_j)}}{H_m(n_j)} \right) \quad (22)$$

$$C_{L,d} = C_L \cdot \left(1 + \frac{2 \cdot \sqrt{d} \cdot \sigma_{H(n_j)}}{H_m(n_j)} \right) \quad (23)$$

The introduction of this correction factor has been evaluated in (Kaplanis & Kaplani, 2006) using the solar radiation data for January and the period 1995-2000 in Patras, Greece, and concluded in a significant reduction in P_m , and C_L with a system reliability level of 95%.

Recent research studies have proposed new developments of stochastic modeling (Balouktsis et al., 2006; Kaplani & Kaplanis, 2011; Markvart et al., 2006; Tan et al., 2010), the use of Hidden Markov Models (Hogaoglu, 2010), and Neural Networks (Kalogirou, 2001; Mellit et al., 2008), for the sizing of SAPV systems. Several of these approaches are iterative approaches based on the concept of energy balance and Loss of Load Probability. The objective being, a search for the minimum required installed P_m and C_L that would cover the energy needs required by the loads for a number of days so that the system remains autonomous. Some configurations may use, in addition, a diesel generator for SAPV system support in autonomous functionality. A SAPV system configuration is displayed in Figure 13.

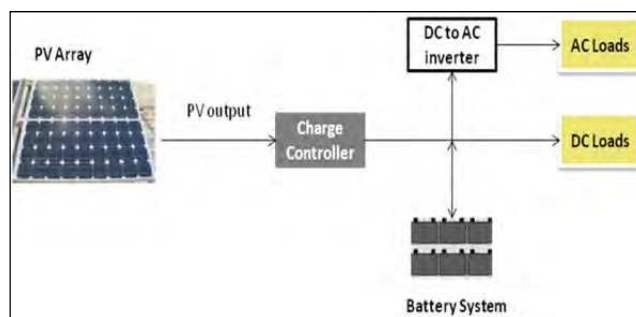

Fig. 13. SAPV system configuration

According to the energy balance concept, eq.(24), the energy offered by the PV array will be used by the loads Q_L , an amount will be dissipated throughout the pathway from the PV array to the loads, i.e. being power losses in cables, in the charge controller, the DC/AC inverter, the battery system, etc., and, finally, the remaining energy will be stored in the batteries.

$$Energy_{offer} - Energy_{demand} - Energy_{losses} = Energy_{stored} \quad (24)$$

Considering a daily description the energy balance equation may take the following form.

$$\sum_{h=hsr}^{hss} A_{PV} I_T(h; n_j) \eta_{pv} \delta h - \sum_{h=1}^{24} q_L(h; n_j) \delta h - \sum_{h=1}^{24} power_{losses} \delta h = Energy_{stored\ per\ day} \quad (25)$$

where A_{PV} is the size of the PV array, $I_T(h; n_j)$ the hourly solar radiation intensity on the inclined plane of the PV array at hour h for a day n_j , and η_{PV} the efficiency of the PV generator. By $q_L(h; n_j)$ we refer to the hourly power demand by the loads. Thus, the energy stored during the day would be the energy remaining from the energy provided by the PV generator, from sunrise to sunset, after it is used up on the loads and an amount 'burnt' due to power transmission and operation losses. During the night, the load power demand is met by the battery storage system, while some power losses from the battery to the loads occur. The remaining energy in the batteries will be carried on to the following day. The battery storage capacity is finite, and, thus, any excess energy after the battery is fully charged will be burnt. Also, the depth of discharge of the batteries, for deep cycle batteries, is about 80%, and, therefore, during a dark period of days when the energy in the batteries has been used up, up to the point where the state of charge (SOC) of the batteries has been reduced to 1-DOD (20%), the batteries will not be able to supply the loads with any more energy and the system will fail.

The energy provided by the PV generator during the day is given by eq. (26), and the remaining energy that will be used to charge the battery is given by eq.(27). The state of charge of the battery after the end of the day is provided in eq.(28). The SOC of the battery will result from the previous SOC with the addition of the remaining energy during the day. The SOC of the battery has an upper limit of 1. Any excess energy will be burnt. The SOC of the battery after the end of the night will be the SOC after the battery is discharged by the power required by the night loads, as given by eq.(29). F and F' are correction factors due to all power losses from the PV generator to the loads, and from the batteries to the loads respectively. These factors should also accommodate any temperature effects or PV ageing and battery ageing effects that reduce the power output.

$$E_{PV} = P_m \cdot PSH \cdot R \quad (26)$$

$$DE = E_{PV} - F \cdot Q_{Lday} \quad (27)$$

$$SOC = SOC + DE / (C_L \cdot V) \quad (28)$$

$$SOC = SOC - Q_{Lnight} \cdot F' / (C_L \cdot V) \quad (29)$$

Thus, for an effective sizing of a PV system the following need to be thoroughly considered:

- the optimum angle of inclination and the azimuth of the PV arrays, and the other geometrical factors concerning the PV arrays, such as possible lay-outs and array dimensions, especially when there are cases of shadowing by nearby buildings or objects.
- the minimum power losses in cables, chargers, due to the margin in their operation and in the inverter(s), especially, when a group of inverters is used. The effect is crucial if the DC/AC inverter operating domain does not match the i-V characteristic of the PV array connected to it. In such cases, the efficiency of the inverter drops much below 90%.
- the sizing of the battery bank, introducing realistic corrections to the system's total Capacity, C_L (Ah), as otherwise the system might be either oversized or undersized.
- the sizing of the PV generator which has to take into consideration the daily load profile, the solar energy fluctuations during the daytime and if possible the pragmatic solar irradiance on a PV generator in any day. The latter requirement has lead, as earlier mentioned, to the introduction of the concept of d days of energy independence of an SAPV installation.

Finally, a dynamic simulation model which provides the daily and/or hourly profile of the energy expected to be delivered by the PV generator, the energy used by the loads and the state of charge of the battery, such as the one presented in (Kaplanis & Kaplanis, 2011), may be found very useful not only for the optimum sizing of the PV generator and battery storage system, but also for the precise evaluation of the forecasted entire system performance and the possibility for application of more efficient controls.

5. Predictive management of PV systems

As several attempts have been recently initiated worldwide towards the development of intelligent buildings with the integration of renewable energy systems, the introduction of predictive PV system management in conjunction with effective load management is of great importance in photovoltaic applications.

A predictive management PV system may be described to have the following modules:

- An inbuilt intelligence for the management of the PV system. This is achieved when the PV system is equipped with the ability to predict the daily global solar radiation profile. Section 3 has presented a dynamic prediction model of the hourly solar radiation profile. This leads to the determination of the pragmatic power to be delivered in a day by the PV plant.
- A data acquisition system, which is tailored to the model management parameters opted for, as for instance the global solar radiation intensity, indoor and outdoor temperature, relative humidity, wind velocity, etc., which is consisted of all the required sensors, such as pyranometer, thermocouples, anemometers, etc.
- A micro-processor control unit, with an analysis and control module.

The configuration of a predictive management PV & Loads system for an intelligent building is provided in Figure 14. It is consisted of the sensors network, the load network

and the control network. The sensors signal output are fed to the data logger, which in turn communicates with the Analysis and Control Module in the PC. Given the information acquired from the sensors the Analysis Module predicts the energy to be delivered during all hours of the day, communicates with the Control module, which manages the loads through priority handling. The Control Module through the Interface to the Loads may then serve the immediate loads and shift flexible low priority loads to the following days, in order to efficiently meet the energy demand. The Control Module could have an additional functionality for remote control, i.e. web-based or via mobile.

A predictive management PV system will be seen to succeed in cases where conventional design methodologies or even more dynamic stochastic models may fail to meet the daily energy requirements. An effective PV sizing installation in conjunction with a predictive management PV system will serve as a long term cost-effective solution for energy saving and efficient energy use.

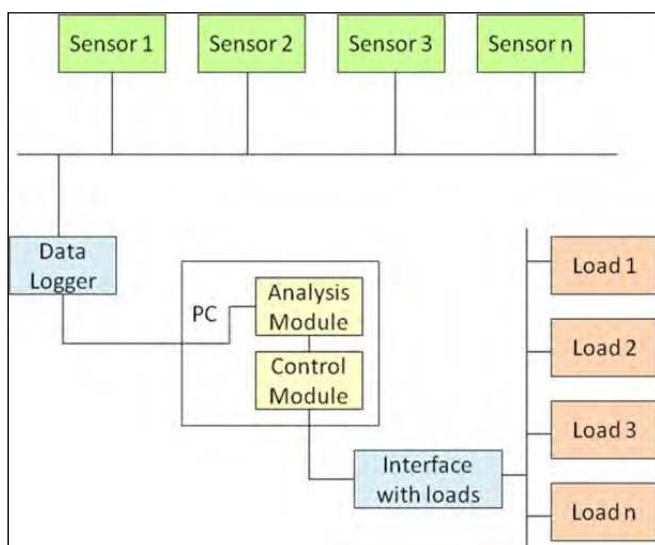

Fig. 14. Configuration of predictive management system for an intelligent building with solar radiation prediction and load management functions.

6. Conclusions

Due to the stochastic nature of the weather conditions, the intensity of the global solar radiation for any hour in any day at any place on the ground cannot be absolutely determined, while this is possible for the extraterrestrial radiation. The stochastic nature of the solar radiation on the ground surface is the weak point in the cost-effective design of solar engineering plants, such as the PV systems, which is the main target of this Chapter. An investigation into the solar radiation fluctuations and their spectra is shown to bring

improvements and innovations in the sizing of solar plants leading to more competitive solutions.

Prediction models for the estimation of the daily and hourly solar radiation profile have been presented and the results were compared with true measured values and values from available databases, revealing very promising methodologies. These are deemed very useful in the sizing of solar energy systems, such as PV generators, solar thermal systems for heating, cooling and other applications; since the amount of either heat or power produced by the solar radiation conversion through solar collectors and PV cell structures respectively, is significantly affected by the solar radiation fluctuations.

Methodological approaches for the effective sizing of PV systems to adequately cover the loads to a predetermined reliability level, may use either expected values resulting from a thorough analysis of past years data, or mean expected global solar radiation values through the use of stochastic prediction models, which showed to bring more cost-effective PV sizing figures, or, finally, benefit from hourly solar radiation on-line prediction models within the scope of a predictive management system for an intelligent energy building. The latter, is a very promising direction for highly cost-effective solutions for the installation and performance of solar energy plants, where the energy offer and the energy demand are both customized and highly optimized.

7. References

- Aguiar, R.J.; Collares-Pereira, M. & Conde, J.P. (1988). Simple procedure for generating sequences of daily radiation values using a library of Markov transition matrices. *Solar Energy*, Vol.40, No.3, pp.269-279.
- Aguiar, R. & Collares-Pereira, M.A., (1992). TAG: A time-dependent, autoregressive, Gaussian model for generating synthetic hourly radiation. *Solar Energy*, Vol.49, No.3, (September 1992), pp.167-174.
- Balouktsis, A. et al., (2006). Sizing stand-alone photovoltaic systems. *International Journal of Photoenergy*, Vol.2006, Article ID 73650, pp.1-8.
- Collares-Pereira, M. & Rabl, A. (1979). The average distribution of solar radiation-correlations between diffuse and hemispherical and between daily and hourly insolation values. *Solar Energy*, Vol.22, No.2, pp.155-164.
- Duffie, J.A. & Beckman, W.A., (1991). *Solar Engineering of Thermal Processes*, John Wiley & Sons, 2nd ed., USA.
- Festa, R.; Jain, S. & Ratto, C.F. (1992). Stochastic modelling of daily global irradiation. *Renewable Energy*, Vol.2, No.1, (February 1992), pp.23-34.
- Gueymard, C. (2000). Prediction and performance assessment of mean hourly solar radiation. *Solar Energy*, Vol.68, No.3, (March 2000), pp.285-303.
- Gueymard, C. (1993). Critical analysis and performance assessment of clear solar sky irradiance models using theoretical and measured data. *Solar Energy*, Vol.51, No.2, (August 1993), pp.121-138.
- Hellenic National Meteorological Service, 2011, Databank of solar radiation data in Greece. Available from: http://www.hnms.gr/hnms/english/index_html

- Hocaoglu, F.O. (2011), Stochastic approach for daily solar radiation modeling. *Solar Energy*, Vol.85, No.2, (February 2011), pp.278-287.
- Iqdour, R. & Zeroual, A. (2007). Prediction of daily global solar radiation using fuzzy systems. *International Journal of Sustainable Energy*, Vol.26, pp.19-29.
- Jain, P.C.; Jain, S. & Ratto, C.F. (1988). A new model for obtaining horizontal instantaneous global and diffuse radiation from the daily values. *Solar Energy*, Vol.41, No.5, pp.397-404.
- Kalogirou, S.A. (2000). Applications of artificial neural-networks for energy systems. *Applied Energy*, Vol.67, pp.17-35.
- Kalogirou, S.A. (2001). Artificial neural networks in renewable energy systems applications: a review. *Renewable and Sustainable Energy Reviews*, Vol.5, No.4, (December 2001), pp.373-401.
- Kaplani, E. & Kaplanis, S. (2011). A stochastic simulation model for reliable PV system sizing providing for solar radiation fluctuations. *Proceedings of ICAE 2011, 3rd International Conference on Applied Energy*, Perugia, Italy, May 16-18, 2011, pp.3503-3516.
- Kaplanis, S. et al., (2002). A comparative study of the clearness index for the region of Achaia using various techniques, *Proceedings of WREN Congress VII*, Cologne, Germany, June 29 -July 5, 2002.
- Kaplanis, S. (2006). New methodologies to estimate the hourly global solar radiation; Comparison with existing models. *Renewable Energy*, Vol.31, No.6, (May 2006), pp.781-790.
- Kaplanis, S. & Kaplani, E. (2006). A comparison of a new PV-sizing approach for stand alone systems with conventional methodologies. *Proceedings of IASTED International Conference EuroPES'2006*, Rhodes, Greece, June 26-28, 2006, pp.332-337.
- Kaplanis, S. & Kaplani, E. (2007). A model to predict expected mean and stochastic hourly global solar radiation $I(h;n)$ values. *Renewable Energy*, Vol.32, No.8, (July 2007), pp.1414-1425.
- Kaplanis, S. & Kaplani, E. (2010). Stochastic prediction of hourly global solar radiation for Patra, Greece. *Applied Energy*, Vol.87, No.12, (December 2010), pp.3748-3758.
- Markvart, T.; Fragaki, A. & Ross, J.N. (2006). PV system sizing using observed time series of solar radiation. *Solar Energy*, Vol.80, No.1, (January 2006), pp.46-50.
- Mellit, A. (2008). Methodology for predicting sequences of mean monthly clearness index and daily solar radiation data in remote areas: Application for sizing a stand-alone PV system. *Renewable Energy*, Vol.33, No.7, (July 2008), pp.1570-1590.
- Messenger, R. & Ventre, J. (2000). *Photovoltaic Systems Engineering*, CRC Press, USA.
- NASA, *Surface meteorology and Solar Energy*. A renewable energy resource web site (release 6.0), 2011, Available from: <http://eosweb.larc.nasa.gov/sse/>
- PVGIS, *Photovoltaic Geographical Information System*, European Commission Joint Research Centre, 2008, Available from: <http://re.jrc.ec.europa.eu/pvgis/>
- RETScreen International, *Photovoltaic Project Analysis*, 2011, Available from: www.retscreen.net
- SoDa, *Solar Radiation Data*, 2011, Available from: <http://www.soda-is.com/>

Tan, C.W.; Green, T.C. & Hernandez-Aramburo, C.A. (2010). A stochastic method for battery sizing with uninterruptible-power and demand shift capabilities in PV (photovoltaic) systems. *Energy*, Vol.35, No.12, (December 2010), pp.5082-5092.

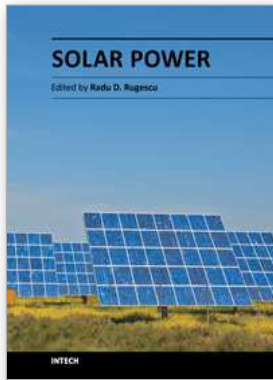

Solar Power

Edited by Prof. Radu Rugescu

ISBN 978-953-51-0014-0

Hard cover, 378 pages

Publisher InTech

Published online 15, February, 2012

Published in print edition February, 2012

A wide variety of detail regarding genuine and proprietary research from distinguished authors is presented, ranging from new means of evaluation of the local solar irradiance to the manufacturing technology of photovoltaic cells. Also included is the topic of biotechnology based on solar energy and electricity generation onboard space vehicles in an optimised manner with possible transfer to the Earth. The graphical material supports the presentation, transforming the reading into a pleasant and instructive labor for any interested specialist or student.

How to reference

In order to correctly reference this scholarly work, feel free to copy and paste the following:

Eleni Kaplani and Socrates Kaplanis (2012). Prediction of Solar Radiation Intensity for Cost-Effective PV Sizing and Intelligent Energy Buildings, *Solar Power*, Prof. Radu Rugescu (Ed.), ISBN: 978-953-51-0014-0, InTech, Available from: <http://www.intechopen.com/books/solar-power/prediction-of-solar-radiation-intensity-for-cost-effective-pv-sizing-and-intelligent-energy-building>

INTECH
open science | open minds

InTech Europe

University Campus STeP Ri
Slavka Krautzeka 83/A
51000 Rijeka, Croatia
Phone: +385 (51) 770 447
Fax: +385 (51) 686 166
www.intechopen.com

InTech China

Unit 405, Office Block, Hotel Equatorial Shanghai
No.65, Yan An Road (West), Shanghai, 200040, China
中国上海市延安西路65号上海国际贵都大饭店办公楼405单元
Phone: +86-21-62489820
Fax: +86-21-62489821