



Title	USE OF BIM FOR CONSTRUTABILITY ANALYSIS IN CONSTRUCTION
Author(s)	YANG, HUI-HSUAN; LEE, MENG-HSING; SIAO, FU-CIH; LIN, YU-CHENG
Citation	Proceedings of the Thirteenth East Asia-Pacific Conference on Structural Engineering and Construction (EASEC-13), September 11-13, 2013, Sapporo, Japan, A-3-1., A-3-1
Issue Date	2013-09-11
Doc URL	http://hdl.handle.net/2115/54212
Type	proceedings
Note	The Thirteenth East Asia-Pacific Conference on Structural Engineering and Construction (EASEC-13), September 11-13, 2013, Sapporo, Japan.
File Information	easec13-A-3-1.pdf



[Instructions for use](#)

USE OF BIM FOR CONSTRUCTABILITY ANALYSIS IN CONSTRUCTION

Hui-Hsuan, Yang^{1†}, Meng-Hsing, Lee¹, Fu-Cih, Siao², and Yu-Cheng, Lin^{3*}

¹*Graduated student, Department of Civil Engineering, National Taipei University of Technology*

²*Senior engineer, BIM Integration Center, CECI Engineering Consultants, Inc., Taiwan.*

³*Associate professor, Department of Civil Engineering, National Taipei University of Technology*

ABSTRACT

The constructability analysis is one of the important and necessary works during the construction phase. The manager and engineer usually utilizes 2D paper-based drawing to make constructability analysis for better understand of progress and conflict of construction work for construction management. The traditional ways of the constructability analysis usually cause time-consuming problems and problem misunderstanding sometime. Furthermore, this problem always decreases the efficiency for engineers and managers using 2D paper-based drawing approach in constructability work. Building information modeling (BIM) is the latest concept and technology in building and construction engineering. The main function of BIM is to enhance constructability analysis thought simulating construction operations by 3D model. This study addresses application of BIM approach in constructability analysis and proposes a BIM-based constructability analysis mechanism during the construction phase. The proposed system is then applied in selected case study in Taiwan to demonstrate the effectiveness of constructability analysis in practice. The combined results demonstrate that, a proposed BIM approach and mechanism can be an effective tool for constructability analysis in construction projects.

Keywords: Constructability; Construction Management; BIM; Construction phase; Building information modeling

1. INTRODUCTION

Design effort is very important because construction starts based on 2D CAD drawings. These design drawings should be certain and accurate to support construction. Moreover, currently, construction project tend to be more complexity than before, and special shape of the building will be difficult to be presented in 2D CAD drawings. In this situation, more problems exist in construction phase if contractors use 2D CAD design efforts directly.

Constructability of designs is always reviewed by engineers using 2D CAD drawings. Engineers have to find out whole clashes among designs of structure, architecture, and MEP from these 2D design efforts. It is very difficult to implement such review works because of better spatial concept need. Moreover, engineers usually find the problems during the construction due to the designs are inconsistent or illogic, for example, the size of one column is changed in the plan drawing but this information is not changed in the elevation drawing; or, designers do not consider construction conditions, leading the working space is not enough for labors. The use of useless information about designs will result in rework or cost increased. Fig. 1 describes the causes of un-good designs using 2D CAD design drawings.

[†] Presenter: Email: c10078@yahoo.com.tw

^{*} Corresponding author: Email: c10078@yahoo.com.tw

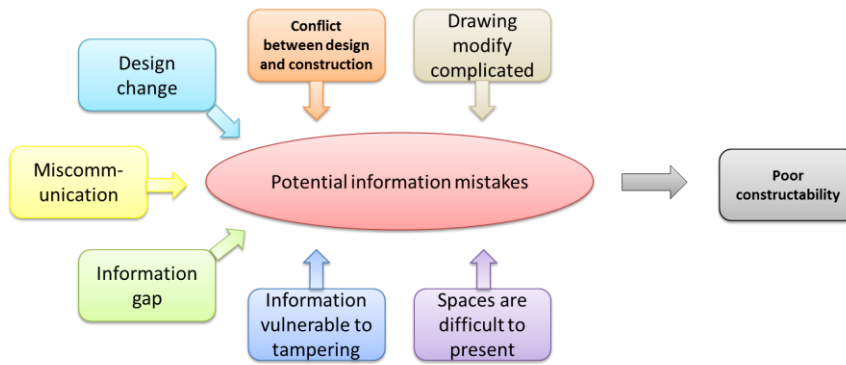

Figure 1. Disadvantages analysis of 2D CAD drawings

Based on the above mentioned, to improve this problem, Building Information Modeling (BIM) is applied to review the constructability of designs. BIM has many advantages for construction project, including a unified database, parts with attribute information, construction drawings output, 3D model etc. Utilizing these advantages, the construction also is assisted such as spatial understanding. Although BIM can assist the review of constructability, there are no management processes regarding the application of BIM in constructability reviews. Thereby, the processes of BIM-based constructability review are proposed in this study.

1.1 Research Objectives

The construction project consists several phases, including conceptual, design, construction, and operation. BIM technology can be applied in each phase of a project. In order to avoid rework and cost waste in construction using typical 2D CAD drawings, the contractor can use BIM to analyze the design before the construction, and BIM is utilized by engineers to identify collisions or illogic designs of the building project as early as possible. The study thus focuses on the discussion of the design reviews by construction engineers such as working space and clashes before the construction starts. Reducing the clashes of designs and increasing communications should be expected by BIM applications. Overall, the objectives of this study are as follows: (1) to propose the procedures of constructability review using BIM technology; and (2) to discuss the differences of using BIM and 2D CAD in constructability analysis, and to then propose advantages of BIM in constructability review. Finally, the proposed processes are applied in the case company of Taiwan to demonstrate the how BIM can support and enhance the performance about the management of BIM-based constructability reviews.

2. LITERATURE REVIEW

2.1 Building information modeling (BIM)

The concept of BIM had proposed in 1970s, but the application was not wide because the hardware of computer was also not enough to support BIM operation. Currently, information technology is better than before so that BIM application is also applied widely. Lots of BIM applications are proposed in academe and industry. Lee et al. (2006) discussed the integration of BIM software and design and engineering knowledge; Wu (2007) developed a framework and visual project management information system to integrate and manage the project information for the project management team; Sacks (2010) developed a lean-construction product management system based on BIM; Lee (2010) applied BIM technology to assist the facility maintenance management; Jung (2011) proposed a building information modeling framework which can be applied in real project analysis. Although many studies had been proposed, no unified procedures about the management

of constructability review using BIM are discussed. Therefore, this study focuses on the application of constructability review supporting by BIM.

2.2 Constructability

Construction interfaces had been identified as a big issue during the construction phase because interfaces may affect the project implementation. Entity interface problem usually refers to not good design efforts. And not good designs also may result in constructability problems such as labors do works difficultly in a too small space. Construction Industries Research and Information Association (CIRIA) define the constructability: the design efforts can be used in the construction phase, and let contractors implement activities easily and smoothly (CIRIA 1983). Based on this definition, the designer must have the understanding of construction but the designer common lacks the construction experience. Therefore, if contractors want to implement activities well, they need to identify the potential problems from initial designs before the construction. Even though there are no problems may be found, this process still needed to be worked. While, Pan (1997) identified the items about affecting constructability during the design and described the construction interfaces could be improved through Design & Build. Chen (2004) combined the construction drawings of different MEP systems to identify the potential impact positions, and she also built the principle for combining drawings of different MEP systems. Hartmann and Fischer (2007) indicated how to review constructability applying 3D and 4D models in a Fulton Street Transit Center case.

According to literature reviews, constructability is a long-term issue and it has been discussed continuously. Moreover, BIM has been concerned that it is a powerful tool to improve the construction process. However, no processes are proposed to support BIM application in analysis of constructability. The following sections will describe how BIM is used within a procedure for reducing not good constructability issues.

3. THE APPLICATION OF BIM IN CONSTRUCTABILITY ANALYSIS

The construction project implementation depends on the quality of designs so designers should concern the integration of different systems such as structure and HVAC system. The interface problems that affect constructability should be eliminated as possible before the construction, reducing the chance of reworks or activity cannot be constructed because space is not enough. Therefore, this paper develops the processes of BIM application for reviewing construction designs to improve the constructability (see Fig. 2). The steps of model review relating to constructability are developed in this process. It is very important for the construction. If serious problems are not found in the step, the performance of BIM application will be low. Thus, senior engineers with construction experience must join to assist constructability identification.

In order to understand the benefit of BIM for constructability, this study retrieve the construction drawings of a building project in Taiwan, and the case BIM model then is developed in this paper. Also, through interviewing with the case engineers, the common encountered construction problems can be classed into three types, including space, measurement, and clash. The following sections describe three issues separately and develop the BIM procedure to address them.

3.1 Space review

The net space for use inside the building is reviewed whether the spatial allocation is available such as the distance between TV and sofa, and the traditional way is to integrate both of engineering dra

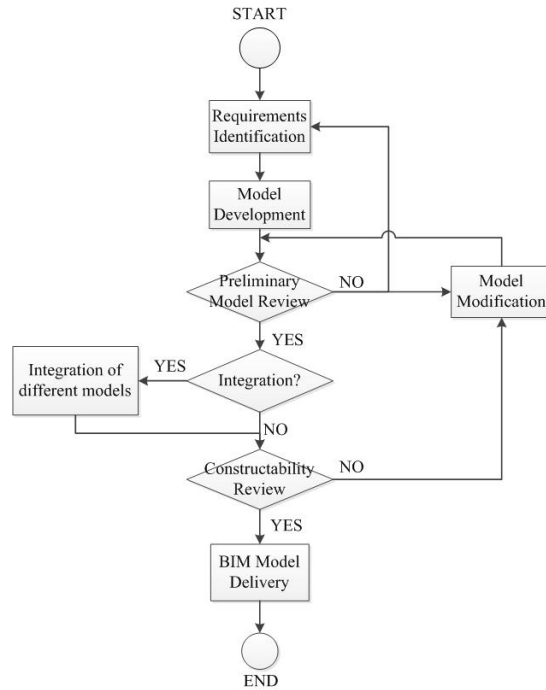

Figure 2. The procedure for constructability review using BIM.

wings related to architecture, structure, and interior decoration. The problems, however, are detected during the integration of these engineering drawings, including the inconsistency drawing versions, complicated lines and notations may be overlap in one integrated CAD drawing, it's difficult to review net elevations, and so on. Therefore, BIM provides a high performance solution for reviewing the integrated design content. Fig. 3 shows a process for users review the constructability about use space. Utilizing BIM model, the work of reviewing space for life use will be easier than before. The visualization is a good approach to enhance the efficiency of identifying poor design about spatial allocation (see Fig. 4a). BIM supports the clear understandings related to spatial allocation for users, just like virtual reality (see Fig. 4b).

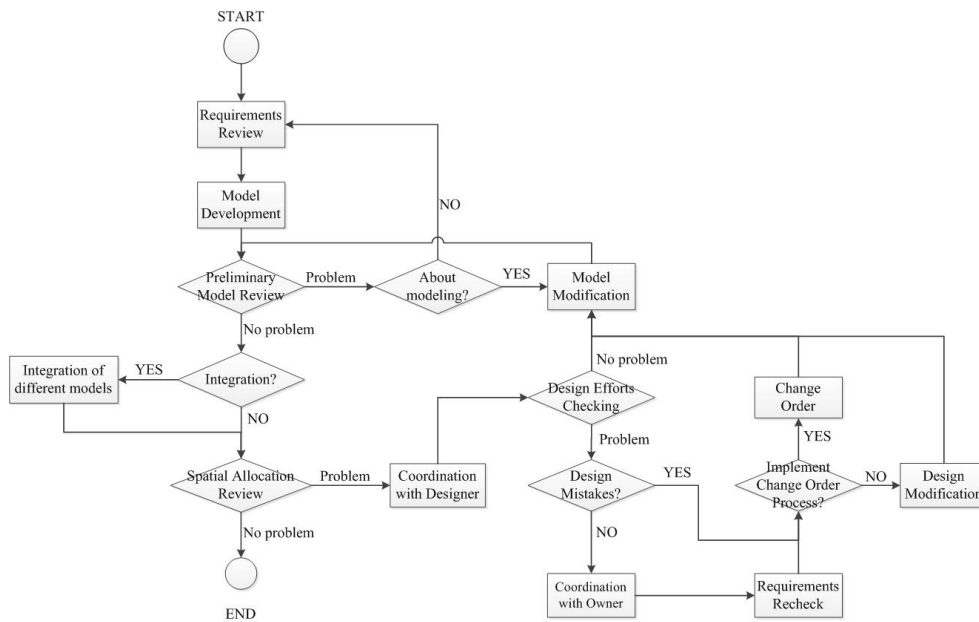

Figure 3. The procedure of BIM-based spatial allocation review.

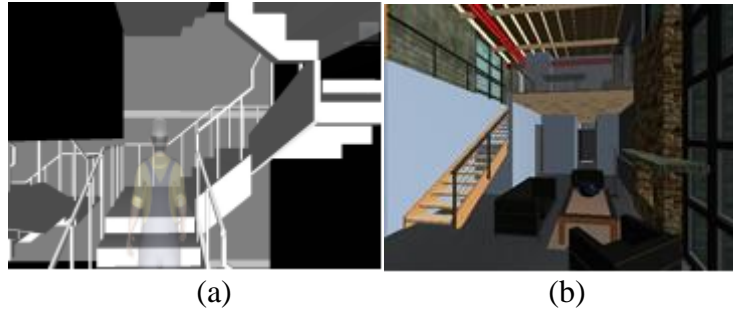

Figure 4. The visualization of BIM for space review.

3.2 measurement review

In the design process, the plan drawing of a building is first accomplished, and the elevation and section drawing are then also produced. The draftsman needs to annotate the measurement in these drawings for showing the relationships of building objects in the space. For example, when the designer changes the stair step number of a stair, the designer must attend to consider the clear height for user climbing. If the draftsman cannot handle the relationships among plan, elevation, and section, the errors of measurement annotation will make the problems after the construction, such as a clear height of a stair is not enough at the staircase for user climbing. To improve this problem, the BIM technology is utilized. Fig. 5 shows a procedure for users check the design about measurement that indicates the relationship between building objects. Utilizing BIM technology, checking measurement design is easier than before. Also, designers enable to ensure the consistency of the design through BIM because of it is database. When a designer move one object or change the properties of one object in the plan view, all drawings of this object included will change at the same time. Moreover, the measurement annotations are also changed if you had been assigned the annotation to this object. Also, designers can check these changes immediately through using two views in one window; Synchronization function is the best advantage for designers (see Fig. 6). However, by apply BIM to implement design works, the measurement check will is easier for users.

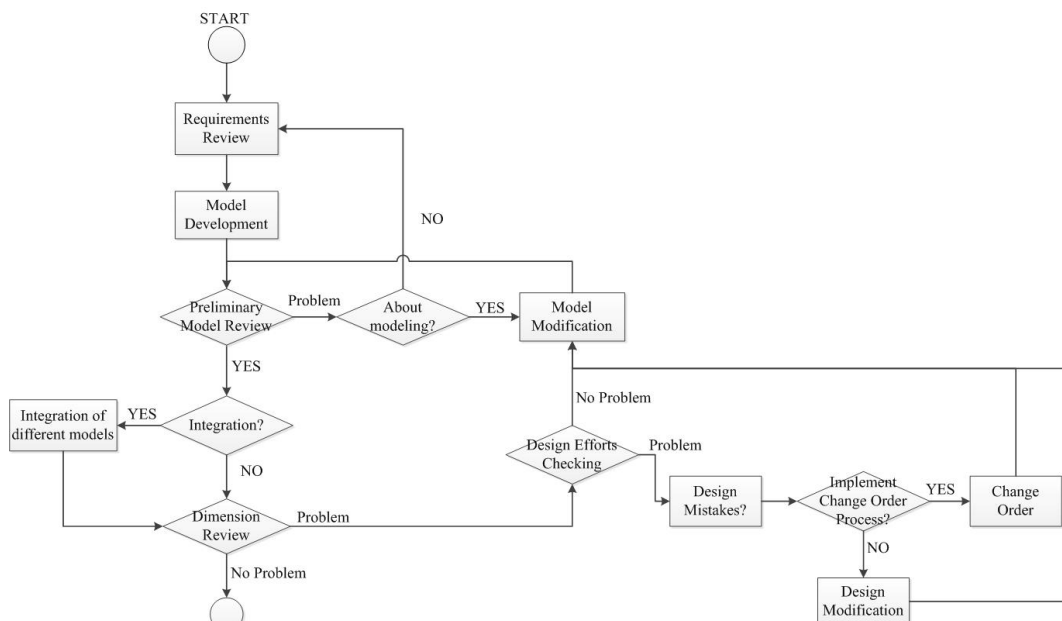

Figure 5. The procedure of BIM-based measurement check.

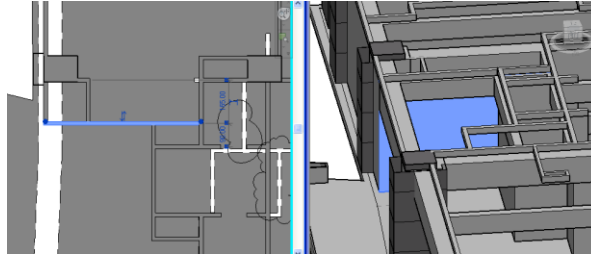

Figure 6. A shown of the BIM design using two views in one window.

Clash detection

The activity of the constructability checking is always implemented by manpower. This is the traditional way for constructability review. However, conflict problems will occur based on this situation. The engineer checks and reviews the engineering drawing, which integrate structure, architecture, and MEP, to detect the clashes and inconsistent building objects by 2D CAD. It is too difficult for engineers. Even the senior and experienced engineer still cannot find out all clashes from 2D CAD because this integrated drawing is serious complexity. However, BIM solution provides a chance to detect and review conflicts easily for engineers. Fig. 7 describes the procedure for engineers to review the clashes during the model development. During modeling BIM model, the modeler can utilize the clash detection function to find out the potential conflicts. The system will create the clash detection report (see Fig. 8a), and then engineers can check these found potential conflicts (see Fig. 8b) and to eliminate them. Based on 3D model review, the clash detection is easier than before, and the consistency can be ensured due to the core of BIM is database when any object is moved, deleted, or changed.

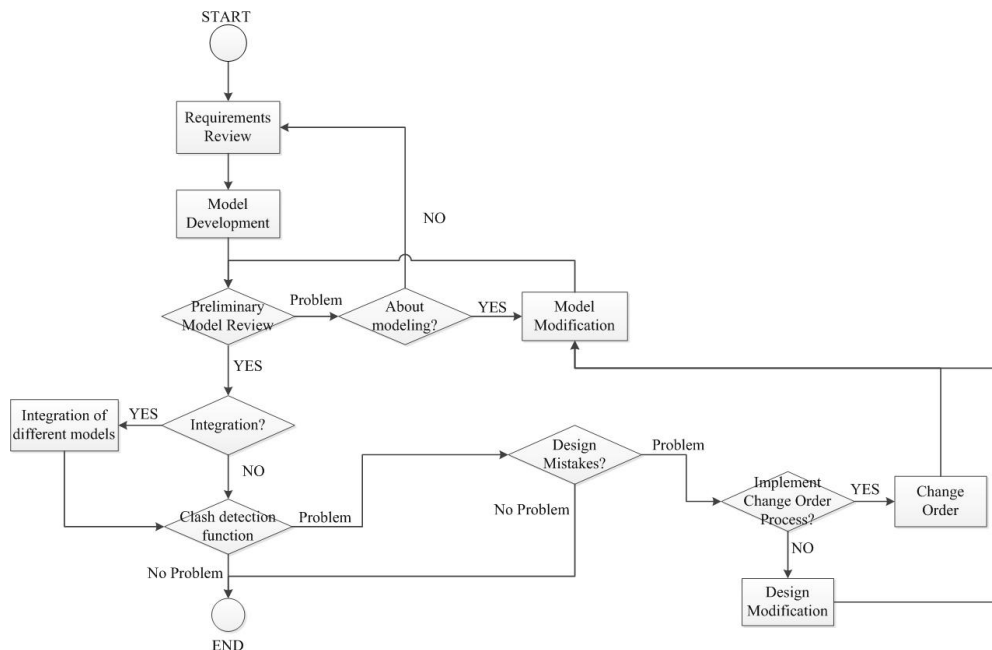

Figure 7. The procedure of BIM-based clash detection

Consequently, the application of the BIM technology can enhance the quality of the construction because engineers can detect conflicts and other construction problems such as construction space is not enough as early as possible. Table 1 shows the differences between 2D CAD and BIM for constructability review.

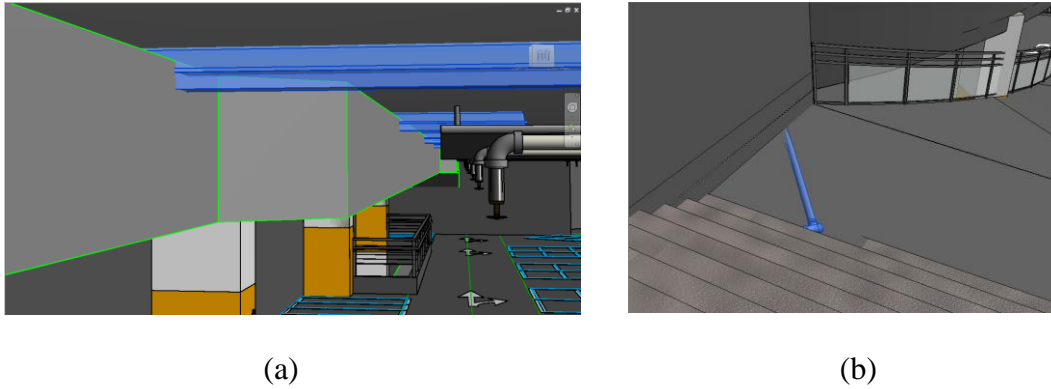

Figure 8. The visualization of BIM for clash detection.

Table 1. The differences between 2D CAD and BIM for constructability reviews.

Item	2D CAD	3D BIM model
Space review	Engineers need best spatial concept and experience, or many potential problems will not be detected.	Engineers can detect the lots of problems directly and easily by 3D design.
measurement check	When design is changed, it is difficult to handle all measurement annotation changes in lots of drawings for designers.	When design is changed in the model, all information about it in any drawing will be changed, keeping the consistency of design.
Clash detection	Engineers need best spatial concept and experience, or many potential problems will not be detected.	Engineers can detect the lots of problems directly and easily by 3D design.

4. CONCLUSIONS

Constructability analysis is very important because the potential problems may be found before the construction. The integrated 2D CAD drawings are always used to detect problems, including space review, measurement check, and clash detection. However, the performance of detecting problems is very low, and each engineer has different spatial concept, leading the difficult coordination. To improve the performance of the constructability review, the three procedures of using BIM in analysis of constructability have been proposed and discussed in this paper. Three procedures are considered to assist three aspects of common problems in Taiwan construction, including space, measurement, and clash. These proposed procedures are then utilized in one case project of Taiwan, and the results indicate BIM is a significant and effective tool for analyzing constructability of designs before construction starts, avoiding the reworks and construction mistakes. There are several advantages of BIM application for constructability review, they are as follows: (1) BIM provides a chance for users check potential design problems easily, (2) The communication can be improved by using BIM because data is consist, and BIM also provides 3D environment to enhance the communication performance, and (3) BIM provides the clash detection function, and the common BIM system can identify clashes of BIM model automatically, and then users must determine these clash information.

The recommendations are found during the interview, they are as follows: (1) the training and workshop should be held for assisting engineers of different departments coordinate by BIM model; (2) although BIM software provides a chance to detect the clashes in the built model automatically, a senior and experience engineer still must join and identifies the real potential conflict problems

based on these results software found; (3) the constructability review not only focuses on entity object relationships, and the non-entity clash constructability review should also be discussed as the following research, such as the pipes exist on top of the door and no entity-conflict between them, and maybe user should consider where the pipes should be.

REFERENCES

- Chen, H-C. (2004). The Study of The Construction Interface Integration of The Mechanical/Electrical System in Building Construction, Master Thesis, the National Taiwan University, R.O.C.
- CIRIA (1983). Buildability: An Assessment. *Special Publication 26: CIRIA*.
- Hartmann, T. and Fischer, M. (2007). Supporting the Constructability Review with 3D/4D Models, *Building Research & Information*, 35(1), pp. 70-80.
- Jung, Y. (2011). Building information modeling (BIM) framework for practical implementation, *Automation in Construction*, 20(2), pp. 126-133.
- Lee, G., Sacks, R., Eastman, C.M. (2006). Specifying parametric building object behavior (BOB) for a building information modeling system, *Automation in Construction*, 15(6), pp. 758-776.
- Lee, Y.C. (2010). The application of building information modeling in property management, Master Thesis, the National Taipei University of Technology, Taiwan, R.O.C.
- PAN, C-C. (1997). A Study of Building Design for Constructability Influence on the Construction Industry, Master Thesis, the National Taiwan University, R.O.C.
- Sacks, R. (2010). Requirements for building information modeling based lean production management systems for construction, *Automation in Construction*, 19(5), pp. 641-655.
- Wu, I-C. (2007). Integration, management and visualization of multi-dimensional information in engineering projects, Ph.D. Dissertation, the National Taiwan University, Taiwan, R.O.C.