



Title	Photocatalysis by inorganic solid materials: Revisiting its definition, concepts, and experimental procedures
Author(s)	Ohtani, B.
Citation	Advances in Inorganic Chemistry, 63, 395-430 https://doi.org/10.1016/B978-0-12-385904-4.00001-9
Issue Date	2011
Doc URL	http://hdl.handle.net/2115/48654
Type	article (author version)
File Information	BADIC.pdf



[Instructions for use](#)

Photocatalysis by Inorganic Solid Materials—Revisiting Its Definition, Concepts and Experimental Procedures

B. Ohtani*

Catalysis Research Center, Hokkaido University, Sapporo 001-0021, Japan

List of Contents

I. Introduction

II. Photocatalysis

A. Definition

B. Photocatalysis and Catalysis

C. Photocatalytic Activity

III. Principle of Photocatalysis

A. Generally Accepted Explanation

B. Band Structure and Excitation

C. Positive Hole

D. Fermi Level

E. Overall Thermodynamics

F. Energy Conversion

IV. Kinetics

A. First-order Kinetics

B. Langmuir-Hinshelwood Mechanism

C. Electron-Hole Recombination

D. Quantum Efficiency

E. Rate-Determining Step

*Corresponding Author. Catalysis Research Center, Hokkaido University, Sapporo 001-0021, Japan. tel.: +81-11-706-9132; facsimile: +81-11-706-9133; e-mail: ohtani@cat.hokudai.ac.jp.

V. Visible Light-induced Photocatalysis

A. Background

B. Doping

C. Proof for Visible Light-induced Photolysis

D. Co-catalyst Loading for Multiple Electron Transfer

VI. Design of Active Photocatalysts

A. Physical Property-Activity Correlation

1. Nano-structured photocatalysts

2. Dependence of Photocatalytic Activities on Physical and Structural Properties

3. Extraction of Intrinsic Effects of Physical and Structural Properties

B. Synergetic Effect

VII. Conclusive Remarks

I. Introduction

After the relatively long history of studies on photocatalysis, it seems unnecessary to explain the importance of photocatalysis in both fundamental and application aspects; for example, coatings of window glass and exterior walls with photocatalysts has already been commercialized worldwide due to its highly beneficial effect of "self-cleaning" which enables the surface to be kept clean under conditions of sunlight exposure and rain (*1*). Since results of many scientific studies on photocatalysis have been reported, it seems rather difficult, at least for the author, to make a complete review by introducing all or a large part of the reported studies on photocatalysis, while, of course, successful reviews (*2,3*) have been published by talented researchers in this field. This review has been written in order to clarify fundamental aspects of photocatalysis, not to present a list of studies on photocatalysis reported so far. Some of the aspects have not been discussed so far as "common sense" in papers relating to photocatalysis. This review is based on the author's experience in studies on photocatalysis for more than twenty-five years and topics are therefore limited to so-called semiconductor photocatalysis (Section II.A, III.A), and consequently the author's results and

interpretations are highlighted. It is the author's pleasure to suggest reading also his recent review (4) on photocatalysis, which may be helpful for understanding the outline of studies on photocatalysis.

II. Photocatalysis

A. Definition

Although various definitions and interpretations of the term "photocatalysis" have been proposed, "photocatalysis" or "photocatalytic reaction" is defined, in this chapter, as a chemical reaction induced by photoabsorption of a solid material, or "photocatalyst", which remains chemically unchanged during and after the reaction. In other words, the solid acts catalytically, without any changes in its composition or structure, under photoirradiation, and this explanation may be consistent with most other definitions. "Photocatalysis" is the conceptual name for photocatalytic reactions. In this context, data can be obtained by measuring consumption of the starting materials and/or formation of reaction products initiated by photoirradiation and then examining whether the photocatalyst or its properties have been modified during the reaction. This seems to be a relatively easy procedure. However, various problems are, in fact, encountered when trying to prove a given phenomenon as being photocatalytic (Section IV.C).

B. Photocatalysis and Catalysis

The most significant difference between photocatalysis and catalysis lies in their thermodynamics. In a general definition, a catalyst reduces activation energy of a given chemical reaction by changing the intermediate states and thereby accelerates the reaction which proceeds spontaneously with negative Gibbs energy change, i.e., catalysis is limited to thermodynamically possible reactions. On the other hand, it is well known that photocatalysis can drive energy-storing reactions, e.g., splitting water into hydrogen and oxygen. In this sense, "photocatalysis" must be recognized as a concept completely different from that of "catalysis". Actually, apparent activation energy of photocatalysis estimated by an Arrhenius plot has been reported to be very small compared with that of catalytic reactions (5).

C. Photocatalytic Activity

The term "activity" is often used in papers on photocatalysis as "photocatalytic activity". Although the author does not know who first started using this term in the field of photocatalysis, people involved in the field of catalysis were using this term before the 1980's, when photocatalysis studies had begun to be accelerated by the famous study of the so-called "Honda-Fujishima effect" on photoelectrochemical water splitting using a single-crystal titania electrode (6). Most authors, including the present author, use the term "photocatalytic activity", but in almost all cases the meaning is the same as that of absolute or relative reaction rate. One reason why we like to use the term "photocatalytic activity" may be that it can make readers think of "photocatalytic reaction rate" as one of the properties or abilities of a photocatalyst, i.e., photocatalysts have individual activity, while "reaction rate" is controlled by the activity under given reaction conditions. In the field of catalysis, "catalytic activity" has been used to show a property or performance of a catalyst, since an "active site" (**Fig. 1**) on a catalyst accounts for the catalytic reaction. The reaction rate per active site can be estimated and should be "catalytic activity". In a similar sense, "turnover frequency", i.e., number of turnover per unit time of reaction to show how many times one active site produces a reaction product(s) within unit time, is also used. On the other hand, there are no active sites on a photocatalyst (7), and the reaction rate strongly depends on various factors such as the intensity of irradiated light which initiates a photocatalytic reaction. Considering at least that the dark side of a photocatalyst or suspension is not directly involved in the photocatalytic reaction, the use of the term "active site" is inappropriate, and a relationship of photocatalytic activities with active sites therefore cannot be expected.

III. Principle of Photocatalysis

A. Generally Accepted Explanation

The principle of photocatalysis is often explained with a figure like **Fig. 2**, a schematic representation of the electronic structures of semiconducting materials, a band model. An electron in an electron-filled valence band (VB) is excited by photoirradiation to a vacant conduction band (CB), which is separated by a forbidden band, a band gap, from the

VB, leaving a positive hole in the VB (Section III.B). These electrons and positive holes drive reduction and oxidation, respectively, of compounds adsorbed on the surface of a photocatalyst. Such an interpretation accounts for the photocatalytic reactions of semiconducting and insulating materials absorbing photons by the bulk of materials. In the definition of "photocatalysis" given above, however, no such limitation based on the electronic structure of a photocatalyst is included. For example, isolated chemical species, not having the above-mentioned band structure, on or in a solid can be a photocatalyst, and even when a bulk material is used, the photoabsorption and resultant photocatalytic reaction may proceed at a localized site when, for example, photocatalysts are photoirradiated at a wavelength near the band gap. An example is a gold-modified titania photocatalyst which induces "photocatalytic" decomposition of organic compounds under aerated conditions by photoabsorption of surface-plasmon resonance of gold particles (8). Therefore, the interpretation using a band model is not always adequate for understanding photocatalysis. In this sense, the term "heterogeneous photocatalytic reaction (photocatalysis)" seems better than "semiconductor photocatalytic reaction" based on the electronic band structure.

B. Band Structure and Excitation

An important point in general understanding of the mechanism of photocatalysis is that photoabsorption and (e^-h^+) generation (**Fig. 3**) are inextricably linked; a VB electron is not excited after photoabsorption. This interband (band-to-band) excitation is often illustrated by three bands, CB, forbidden band (band gap) and VB, in which an electron moves vertically from the VB to CB, i.e., no spatial change in the position of electron, though the author sometimes encounters misunderstanding that an electron migrates from VB to CB spatially. Anyway, the above-mentioned interpretation seems a little strange considering the meaning of band structure and band-to-band transition, in which electrons are not localized and therefore electrons and positive holes can migrate within a crystal; an unlocalized excitation state may be described as "photoexcited crystal", e.g., an excited state of titania, without showing localized e^-h^+ . Do e^- and h^+ migrate in the CB and VB, respectively, after photoabsorption, i.e., photoexcitation? When we illustrate the electronic structure of a molecule, lines are drawn to show the electronic state (**Fig. 3**); the length of these lines does

not mean spatial distribution of electrons in those states. This should also be the case for semiconducting (or insulating) materials, and band-to-band transition just means that an electron in the VB is excited to the CB without clarifying the location of e^- and h^+ . Sometimes we, at least the present author, misunderstand that e^- and h^+ migrate to the surface (Right or left end of the CB and VB in **Fig. 3** is often assigned to "surface").

A possible interpretation for better understanding for e^- - h^+ location is that there are sites trapping e^- or h^+ in the crystal lattice and that e^- and h^+ are trapped by these sites "immediately" after the band-to-band transition, i.e., photoabsorption (9). Location of e^- and h^+ in the initial stage of photocatalysis as well as the rate should be controlled by the density and spatial distribution of these traps in a photocatalyst. However, there is little information on the density and spatial distribution of traps, since the structure of traps has not been fully clarified (10).

C. Positive Hole

A significant problem in studies on photocatalysis is the definition of "positive hole". Positive hole is defined as a defect of an electron (i.e., a positive hole must be included in a substance, while an electron is a real substance). Therefore, not only h^+ produced by photoinduced band-to-band transition in solid materials but also a hydroxyl radical, which is a one-electron deficient hydroxyl anion, can be a positive hole. If this definition is accepted, there should be no difference in the photocatalytic oxidation mechanisms between "direct hole transfer" and "surface-adsorbed hydroxyl radical reaction", since it is well known that the surface of a metal oxide is covered with chemically or physically adsorbed water and a positive hole passing through this water layer into a solution may be a hydroxyl radical or its protonated or deprotonated species (**Fig. 4**). Actually, hydroxyl radicals were detected in a suspension of titania particles under ultraviolet irradiation (11,12). Although the author does not know from when people in this field believed that photocatalysis, especially by titania, includes oxidation of organic substrates by hydroxyl radicals that are liberated by the reaction of positive holes and surface-bound water or hydroxyl groups, the detection of hydroxyl radicals might be the reason for this misunderstanding. A problem is the difficulty in obtaining proof for a certain reaction intermediate; one acceptable way to show intermediacy

of a species is to show the disappearance of an intermediate, when a reaction substrate is added, with the rate being the same (but in the opposite direction) as that of liberation of a product. However, as far as the author knows, there have been no reports showing this for hydroxyl radical.

D. Fermi Level

Fermi level is a kind of measure of equilibrium electronic energy of a solid material. It is thought that Fermi level is located just below the CB bottom and above the VB top for n-type and p-type semiconducting materials (13), respectively. Most metal oxides are categorized as n-type semiconductors with Fermi levels more cathodic (higher) than the standard electrode potential of electrolyte in contact with the metal oxide and thereby electrons in donor levels a little below the CB are injected into the electrolyte to form a space charge (depletion) layer with an electric field, i.e., Schottky barrier. In the 1980's, it was thought that this inner electric field separates e^-h^+ effectively; i.e., e^- and h^+ migrate to the bulk and surfaces of semiconductor electrodes and particles, but it seems that this is not the case for untreated photocatalyst particles because of the expected large thickness of this layer due to very low density of donor levels in ordinary photocatalyst particles.

E. Overall Thermodynamics

Change in Gibbs energy (ΔG) of a given photocatalytic reaction is often discussed in chemistry. If ΔG is negative ($\Delta G < 0$) and positive ($\Delta G > 0$), the reaction releases and absorbs energy, respectively, and both situations are possible for photocatalytic reactions. Why can photocatalysts drive a reaction of positive ΔG which does not proceed spontaneously? A possible answer is that a redox reaction can be achieved, even if the overall ΔG is positive, in a system in which reduction and oxidation steps are spatially or chemically separated, otherwise reaction between reduction and oxidation products proceeds to give no net products. Under these conditions, both of Gibbs energy change for reactions of e^- with oxidant (ΔG_e) and h^+ with reductant (ΔG_h) are required to be negative, i.e., reactions by e^- and h^+ proceed spontaneously after photoexcitation (**Fig. 2**). As discussed in Section III.A, it is often emphasized that a thermodynamic requirement for photocatalytic reaction is more cathodic and anodic levels of the CB bottom and VB top compared with the

standard electrode potential of an oxidant and a reductant, respectively, to make Gibbs energy change of both reactions negative. However, this is only one of necessary conditions and another important necessary condition, though negligibly discussed, is separation of reduction and oxidation by e^- and h^+ , respectively, for both types of reaction with positive and negative ΔG (14). Actually, many studies have revealed "potential photocatalysts" for photoinduced water splitting using two kinds of model reaction for hydrogen and oxygen production from aqueous methanol and an aqueous solution of silver salt; production of hydrogen and oxygen in each reaction proved that positions of the CB bottom and VB top are more cathodic and anodic compared with the standard electrode potentials for H^+/H_2 and O_2/H_2O systems, respectively, though only a few photocatalysts could produce hydrogen and oxygen at the same time in the absence of sacrificial electron donors and acceptors.

F. Energy Conversion

Photocatalytic and photoelectrochemical cleavage of water produces hydrogen (H_2), as an ideal fuel emitting only water, and oxygen (O_2) and many researchers are trying to establish a highly efficient system for water splitting under solar radiation. Since this reaction requires input of energy due to its positive Gibbs energy, energy of light is used. The efficiency of conversion of light energy to chemical energy thus becomes important (15). It should be noted that there are at least two kinds of methods for calculation of the efficiency: number (molar amount)-based and energy-based methods. The former is the same as "quantum efficiency", which is calculated as a number ratio of product(s) and photons absorbed by (quantum efficiency) or incident on the reaction system (apparent quantum efficiency; ϕ in **Fig. 5**) per time unit. For discussion on energy conversion, the latter energy-based calculation should be used. Since the energy of H_2 (and O_2) shown in the difference in electrochemical potential, i.e., electromotive force (emf), is 1.23 eV, energy conversion efficiency is 100% when light of 1.23-eV energy (ca. 1000-nm wavelength) is absorbed completely by a photocatalyst and all liberated e^- and h^+ are used for water cleavage. The most significant point of photocatalysis and photoelectrochemical reaction is that even if light of energy much greater than the band gap of semiconducting materials as a photocatalyst or photoelectrode is used, potential of e^- and h^+ is fixed at the position of the CB bottom and VB top, respectively.

Therefore, the energy conversion efficiency is halved when 2.46-eV light (504 nm) is used with constant apparent quantum efficiency (**Fig. 5 (a)**). Although it is often claimed that extension of the limiting wavelength of absorption by photocatalysts and photoelectrodes is necessary in order to utilize solar energy more efficiently, relatively low energy-conversion efficiency at a shorter wavelength has still not been improved. It should also be pointed out that there is a limitation of the longer wavelength side depending on the reaction to drive, e.g., ca. 1000 nm at longest for water splitting as described above (16).

There is still a problem in calculation of energy conversion efficiency when electrochemical or chemical bias is also applied in photoelectrochemical or photocatalytic reaction of positive Gibbs energy. For example, as shown in **Fig. 5 (c)**, energy conversion efficiency for a photoelectrochemical system consisting of an n-type semiconductor and metal counter electrodes with bias voltage Δb is possibly expressed as follows.

$$(\text{energy conversion efficiency}) = \phi \frac{\Delta G - \Delta b}{E_{\text{photon}}}. \quad (\text{eq. 1})$$

However, the reasonability of this calculation has been scarcely discussed so far.

IV. Kinetics

A. First-order Kinetics

It is well known that first-order kinetics is commonly observed for reactions occurring in homogeneous phases, i.e., reactions in homogeneous solutions or in gas phase. Ideally, rate of a mono-molecular reaction obeys first-order rate expression which is explained by that the proportion (number) of molecules that have kinetic energy larger than the activation energy is determined only by the temperature of reaction and actual number of molecules with energy for activation is proportional to the concentration (or pressure) of molecules. For these reactions, kinetic data are analyzed by plotting the logarithm of concentration of a substrate or a product against time of the reaction (17) to obtain a linear line, and absolute value of the slope of the line is a rate constant, k (**Fig. 6**). The rate (r) of consumption of a substrate (A) is shown by the following equation.

$$r = -\frac{d[A]}{dt} = k[A]. \quad (\text{eq. 2})$$

On the other hand, kinetics of reactions occurring on a solid surface, i.e., catalysis or photocatalysis, must be significantly different. There may be two representative extreme cases. One is so-called a "diffusion controlled" process, in which surface reactions and the following detachment process occur very rapidly to give a negligible surface concentration of adsorbed molecules, and the overall rate coincides with the rate of adsorption of substrate molecules. In this case, the overall rate is proportional to concentration of the substrate in a solution or gas phase (bulk), i.e., first-order kinetics is observed (18). The other extreme case is so-called "surface-reaction limited", in which surface adsorption is kept in equilibrium during the reaction and the overall rate coincides with the rate of reaction occurring on the surface, i.e., reaction of e^- and h^+ with surface-adsorbed substrate (19). Under these conditions, the overall rate is not proportional to concentration of the substrate in the bulk unless the adsorption isotherm obeys a Henry-type equation, in which the amount of adsorption is proportional to concentration in the bulk (20). In the former case, the rate of photocatalytic reaction obeys the first-order rate law, but this is only formal and does not mean the mechanism of monomolecular reaction with activation energy.

One of the most significant points that we must consider in scientific studies, not limited to studies on photocatalysis, is distinction between "evidence" and "consistency", as least as far as the author thinks. In other words, it is necessary to recognize every fact to be a "necessary condition" but not a "sufficient condition" in a strict scientific sense. For example, the fact that a reaction rate obeys the first-order rate law giving a linear relation in a plot of data as in **Fig. 6** is only a necessary condition for a monomolecular reaction in homogeneous phase and also a necessary condition for heterogeneous photocatalytic reaction in diffusion-limited conditions or that in surface-reaction limited conditions with a Henry-type adsorption or a Langmuir-type adsorption in the lower concentration region.

B. Langmuir–Hinshelwood Mechanism

The term "Langmuir–Hinshelwood mechanism" has often been used in discussion of the mechanism of photocatalytic reaction in suspension systems, but, as far as the author

knows, there has been no definition given for the Langmuir–Hinshelwood (L–H) mechanism in photocatalytic reactions. In most cases, authors have claimed that a photocatalytic reaction proceeds via the L–H mechanism when a linear reciprocal relation is observed between the reaction rate and the concentration of reaction substrate in a solution. These experimental results seem to be consistent with the following equation:

$$r = \frac{ksKC}{KC + 1}, \quad (\text{eq. 3})$$

where r , k , K , s and C are rate of the reaction, rate constant of the reaction of the surface-adsorbed substrate with e^- (h^+), adsorption equilibrium constant, limiting amount of surface adsorption and concentration of substrate in the bulk at equilibrium, respectively (21), when the substrate is adsorbed by a photocatalyst obeying a Langmuir isotherm and the adsorption equilibrium is maintained during the photocatalytic reaction, i.e., the rate of adsorption is faster than that of the reaction with electrons or holes (Section III.A). Such a situation is often called "light-intensity limited", i.e., photoabsorption is the rate-determining step (22). Several methods for linearization of eq. 3 have been reported, but two kinds of plots are often employed for analysis. As shown in Fig. 7, the most popular one is a plot of reciprocal rate against reciprocal concentration, and another one is a plot of ratio of concentration to rate against concentration. Both plots give ideally the same values of parameters, ks and K , while the former plot reflects mainly lower-concentration data with probable relatively large experimental error.

The original meaning of the term "Langmuir–Hinshelwood mechanism" in the field of catalysis is, to the author's knowledge, a reaction of two kinds of molecules proceeding on a surface in which both molecules are adsorbed at the same surface adsorption sites with the surface reaction being the rate-determining step (in the original meaning of "rate-determining step"). Of course, the general rate equation for the L–H mechanism (not shown here) includes two sets of parameters for two kinds of molecules, and when one set of parameters is neglected, the equation is for a monomolecular reaction, similar to the photocatalytic reaction of a substrate adsorbed in Langmuirian fashion. However, at least in the field of catalysis,

the term L–H mechanism is rarely used for such monomolecular surface reactions, since the L–H mechanism has been discussed for a bimolecular surface reaction by comparing with the Rideal-Eley mechanism, in which a surface-adsorbed molecule reacts with a molecule coming from the bulk.

Even if the L–H mechanism is defined as the reaction of a surface-adsorbed substrate obeying a Langmuir isotherm governing the overall rate, the frequently reported experimental evidence, a reciprocal linear relation between concentration of the substrate in solution and rate of photocatalytic reaction is not always proof of this mechanism. From the linear plot, two parameters are calculated (23). One (often shown as " k ", not as " ks ") is a limiting rate of the reaction at the infinite concentration giving maximum adsorption, i.e., ks , and the other is the adsorption equilibrium constant, K . The former parameter is a product of rate constant and adsorption capacity of a photocatalyst and this may be a photocatalytic activity. The latter parameter shows the strength of adsorption and must be the same as that estimated from an adsorption isotherm measured in the dark. If kinetically obtained K is different from that obtained in dark adsorption measurement, the L–H mechanism cannot be adopted. Therefore, dark adsorption measurement is always required. Finally, it should be noted also in this case that a linear relation fitting to a Langmuir-type adsorption isotherm and similarity of adsorption equilibrium constant evaluated using photocatalytic reaction rate and by dark adsorption experiments are only required conditions; the observed reaction rate is "consistent" with kinetics of a substrate undergoing Langmuir-type adsorption and does not exclude the possibility of other reaction kinetics (24).

C. Electron-Hole Recombination

Recombination of e^- and h^+ occurs in photocatalysts in some degree and it has been believed that this reduces quantum efficiency, i.e., efficiency of e^- - h^+ used in the chemical reaction(s), and overall photocatalytic reaction rate. Since recombination does not produce any chemicals, it is not easy to estimate the rate of recombination directly. One possible way for estimation of recombination rate is to subtract the overall rate of chemical reaction by e^- - h^+ from the rate of photoabsorption, but the obtained data cannot give any other information.

Kinetics of e^-h^+ recombination may depend on its mode; if one electron is excited and this is recombined with h^+ , the recombination rate obeys the first-order rate law, while if multiple e^-h^+ appears at the same time within a photocatalyst particle, the rate obeys the second-order rate law. Actually, in a femtosecond pump-probe diffuse reflection spectroscopic analysis of titania samples, photoabsorption at 620 nm by trapped electrons showed second-order decay with a component of baseline as follows.

$$(\text{absorption}) = \alpha \left\{ \frac{[e_0]}{1 + k_r [e_0] \times t} + BL \right\}, \quad (\text{eq. 4})$$

where α , $[e_0]$, k_r , t and BL are a constant, initial concentration of trapped electrons at time zero, second-order rate constant, time after pump pulse (310 nm) and baseline component, respectively (25). A baseline component might correspond to electrons trapped in deep traps. Different from kinetic analysis based on the first-order rate law (Section III.A), analysis based on the second-order rate law requires absolute values of concentration ($[e_0]$ in **eq. 4**) and photoabsorption coefficient (α in **eq. 4**) of a target compound, but these can not be determined experimentally, at least when the analyses are performed and calculation is performed assuming α to be unity. An example of these kinetic analyses is shown in **Fig. 8** for Degussa (Evonic) P25 (26). Although the thus-obtained second-order rate was relative, it was observed that k_r 's of different titania samples in the form of powder are proportional to those in suspension systems, suggesting that k_r can be a measure of rate of recombination. However, it must be noted that such a second-order recombination process cannot be reproduced in an ordinary photoirradiation process in which lower light intensity induces single-electron photoexcitation and mutual recombination occurs obeying the first-order rate law (27).

D. Quantum Efficiency

The term "quantum efficiency" or "quantum yield" was originally defined as a ratio of number of products (or consumed starting material) to that of absorbed photons in photoreaction in homogeneous phase, i.e., in solutions or gas phase, assuming that one photon induces reaction or change in one molecule since a multiple-photon process and subsequent

multiple-electron transfer can be neglected in ordinary photoirradiation conditions with relatively low photon flux. Confusion might arise when this concept is applied to photocatalysis, in which a multiple-photon process and at the same time radical chain reaction may be included, especially in reaction in the presence of oxygen.

In a heterogeneous photocatalytic reaction, in which multiple photons are absorbed due to the relatively large size of particles compared with the size of molecules, multiple-electron (positive hole) transfer may occur. For example, photocatalytic silver metal deposition accompanied by molecular oxygen (O₂) liberation proceeds with the following stoichiometry (28):

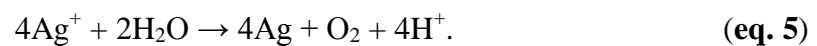

For the determination of quantum efficiency, it is necessary to make an assumption on how many photons are required for the reaction. One of the possible and the most frequently employed assumptions is that four photons are required for liberation of one oxygen molecule, four silver metal atoms, or four protons, and when the O₂ yield is used, the quantum efficiency is calculated to be

$$\frac{4n(\text{O}_2)}{n(\text{photon})}, \quad (\text{eq. 6})$$

where n is the number of molecules or photons. Thus, for the calculation of quantum efficiency of heterogeneous photocatalytic reactions, it is reasonable to consider the efficiency of utilization of electrons-positive holes assuming that an electron and positive hole pair is produced by absorption of a photon. However, since neither a photoexcited electron nor a positive hole appears in stoichiometry, the above-mentioned consideration may not always be straightforward. For example, acetic acid dissolved in air-saturated water is decomposed into carbon dioxide by an appropriate suspended photocatalyst with the following proposed stoichiometry:



How many photons are required for this reaction? Assuming that only O₂ is reduced by

photoexcited electrons in this reaction and that reduction of an O_2 molecule requires four electrons, this reaction is an eight-electron process. However, since the photocatalytic reaction of acetic acid may include a radical chain mechanism or at least addition of O_2 to intermediate radicals, an acetic acid molecule could be decomposed by less than 8 electrons. It is impossible to calculate intrinsic quantum efficiency, i.e., efficiency of utilization of electron-positive hole pairs, only from the product yield. Therefore, quantum efficiency is reported with the description that a given reaction is assumed to proceed through a proposed multiple-electron process (e.g., 8 for the acetic acid decomposition in **eq. 7**).

Another problem for the determination of quantum efficiency is the difficulty in determining the number of absorbed photons. Unlike measurement for homogeneous solutions, solid materials scatter incident photons to reduce the light intensity arriving at a detector in a spectrophotometer. In the wavelength region in which only some of the photons are absorbed, i.e., around the band-edge wavelength, it is difficult to measure the photoabsorption efficiency. Therefore, apparent quantum efficiency (photonic efficiency) has often been used instead of quantum efficiency, and apparent quantum efficiency is calculated by the number of incident photons rather than the number of photons used for quantum efficiency calculation. Since quantum efficiency is defined as efficiency of electron-positive hole utilization, apparent quantum efficiency is a product of efficiencies of photoabsorption and electron-positive hole utilization. Of course, both quantum efficiency and apparent quantum efficiency depend on the irradiation wavelength and sometimes on the irradiation intensity, and thereby the data should be shown with wavelength and preferably with intensity. In this sense, such measurement must be performed by monochromatic irradiation; irradiation with sharp-cut optical filters is inappropriate.

E. Rate-Determining Step

Assuming that a certain reaction proceeds through a series of steps without any branching reactions, the rate must be the same as the rate of the slowest step, the rate determining step, i.e., the overall activation energy is that of the rate-determining step (**Fig. 9**). This original definition cannot be directly applied to photocatalysis. A possible reason is that reactions by photoexcited electrons and positive holes occur in parallel, not in series (**Fig.**

9). Considering the requirement of photocatalysis for the same numbers of electrons and positive holes to be used (consumed), it seems possible to compare the rates of electron and positive-hole reactions. However, it seems that the overall reaction rate is also influenced by recombination of e^-h^+ . In ordinary photochemistry in homogeneous phase, steady (stationary)-state approximation is used to analyze the kinetics, assuming forward reaction to give products and backward reaction, i.e., deexcitation. In such analyses, there may be no rate-determining step.

IV. Visible Light-induced Photocatalysis

A. Background

It has been claimed since the early stage of studies on photocatalysis that only one possible drawback of titania is its photoabsorption wavelength range shorter than ca. 400 nm; titania can absorb ultraviolet light included a little in solar radiation (29). Since solar radiation includes light of wavelengths from 280 to 4000 nm, use of photocatalysts that absorb light in visible and near-infrared regions is highly desired. However, light of longer wavelength has smaller energy, leading to a decrease in potential for redox reactions, and thereby reactions driven by visible-light irradiation are limited to those satisfying the thermodynamic and kinetic requirements (Section II.E and F). Many studies have been performed to design and develop photocatalysts that work under visible-light irradiation.

First, the boundary wavelength between ultraviolet light and visible light should be defined. The meaning of the term "visible light" is light that can be seen, and the limiting wavelength differs among individuals. Many studies demonstrating that visible light induced, as expected, a photocatalytic reaction used the condition of photoirradiation through an optical cut-off filter, L-42 or its equivalent, and the irradiation wavelength under such conditions used to be described as "> 420 nm". However, this is inadequate because this filter transmits light of wavelength > ca. 390 nm (30). Actually, in the author's experience, appreciable photocatalytic activity of not only rutile but also anatase titania photocatalysts could be observed by irradiation through the filter. When this optical filter is used for irradiation, at least comparison of the photocatalytic activity with that of a representative

titania photocatalyst, such as P25 (Degussa (Evonic)) or ST-01 (Ishihara Sangyo), is necessary. Otherwise, optical cut-off filters of longer transmission limits should be used. One of the possible and smart ways is to define "visible light" as light that gives photocatalytic reaction product less than the detection limit of analyses by titania and to use an appropriate optical filter to realize this, considering the history of studies on photocatalysis.

B. Doping

Strategies that have usually been employed, since the discovery of visible light-induced activity of nitrogen-containing titania particles by Asahi et al. (31), in studies on visible light-induced photocatalysis are modification (doping) of titania to give visible-light absorption or use of colored mixed metal oxide and nitride. Although it is expected that such doping of crystalline and mixed metal oxide/nitride may induce production of lattice defects, which enhance electron-hole recombination, resulting in lower photocatalytic activity (32), discussion of the strategies is not a purpose of this review. Some problems in the studies on visible light-photocatalytic activity are discussed here.

One possible reason for the explosive growth in the number of papers on doped material is an unclear definition of the term "doping". As far as the author knows, the meaning of "doping" is incorporation of atoms or ions in a crystalline lattice, i.e., modification of the bulk structure of crystallites, but not modification of surfaces. However, as far as the author knows, such location of hetero atoms or ions has negligibly been discussed (33). If an adequate analytical method(s), if any, is (are) employed, average density of hetero atoms/ions can be determined, and if mapping of elements can be performed with higher sensitivity, spatial distribution may be elucidated. The effect of doping must be discussed on the basis of this structural information, though there have been few reports containing such discussion so far. In relation to this problem, recent papers claimed that in procedure for nitrogen doping using urea, heptazine derivatives are produced on the surface of titania particles and work as a photosensitizer and/or photocatalyst (34), i.e., nitrogen is not "doped" in the titania lattice but is included as a surface modifier.

C. Proof for Visible Light-induced Photocatalysis

Even if introduced hetero atoms/ions are not "doped" in the lattice, it is useful to

prepare modified photocatalysts with visible-light absorption by introducing hetero atoms/ions. One problem, however, is that only newly appearing visible-light photoabsorption and photoinduced reaction rate under visible-light photoirradiation are often described in papers. As the author's group reported, the use of organic dyes for a photoinduced degradation test is inappropriate because those dyes might be adsorbed and work as visible-light photosensitizers, and it is preferable to show resemblance of absorption (diffuse reflection) and actions spectra, i.e., photocatalysis by doped (modified) photocatalysts can be proved through action spectrum analysis (See "Wavelength dependence"). **Figure 10** presents representative results proving visible-light response of sulfur-doped titania (35), as a rare case among studies on visible light-sensitive photocatalysts, showing the resemblance of a diffuse-reflectance spectrum with an action spectrum for photocatalytic oxidative decomposition of acetic acid in aerated aqueous solution; doping of (or at least modification with) sulfur induced photoabsorption and photocatalytic activity in the visible-light region. In other words, showing that a certain reaction proceeds under the above-mentioned visible-light irradiation conditions is not proof of visible light-induced photocatalytic activity unless an appropriate compound is used for the photocatalytic activity test. Dyes have relatively large photoabsorption (extinction) coefficients (This is the reason why they are used as dyes, i.e., coloring agents.) and therefore measurements of their concentrations in solutions are easy even if the concentrations are very low. However, the fact that dyes absorb visible light indicates that a photoreaction might be induced by visible-light photoabsorption (dye sensitization) as well as by photoabsorption of a photocatalyst. Although this problem had been pointed out earlier, there have been no clear experimental results showing the self-photodecomposition of dyes, presumably due to the difficulty in determining the mechanism of this photoreaction. Actually, determination of the extent to which incident photons are absorbed by a dye and photocatalyst is difficult. A paper has been published to show that methylene blue (MB), the most frequently employed dye, as well as, presumably, other kinds of organic dyes, is inappropriate as a model compound, particularly for testing visible light-induced photocatalytic activity (36) There are at least three reasons for its inappropriateness. One is that the dye molecules absorb photons, especially in the

visible-light range, and thus-photoexcited electrons may be injected into photocatalyst particles as has been suggested by similarity of the action spectrum similar to the photoabsorption spectrum of the dye (37,38,39) (**Fig. 11**). Another reason is that the absolute molar amount of dye contained in the reaction system can be much smaller than that of a solid photocatalyst. The concentration of dye in the solution should be relatively low since the absorption coefficient is large. These two facts are closely related to the problem of how we can prove a given reaction to be "photocatalytic", as discussed in Section II.A. The third reason is that the mechanism of dye degradation is so complicated that efficiency of the photocatalytic reaction, e.g., quantum efficiency, cannot be measured. Measuring the consumption (decrease) of a dye during photoirradiation requires only a spectrophotometer, but the use of dyes as model compounds is inappropriate, and if dyes are used, care must be taken in the analysis of experimental results.

An action spectrum is a plot of apparent quantum efficiency, not quantum efficiency, against wavelength of light used for apparent quantum efficiency measurement. Therefore, it is clear that monochromatic light irradiation is required to record an action spectrum. Usually, a grating-type monochromator is used with a light source such as a xenon arc lamp. Interference-type optical filters, transmitting at only a certain wavelength region, are also used for monochromatic irradiation, though wavelengths of possible irradiation are limited. Because of possible dependence of apparent quantum efficiency on light intensity (40), it is preferable to adjust the light intensity at each wavelength (41). Wavelength-selective irradiation can be carried out using optical filters that transmit light of wavelength longer than a certain limit, i.e., "cut-off filters". By using a number of filters with different cut-off wavelengths, a plot of apparent quantum efficiency against the cut-off wavelengths can be obtained, and this "pseudo action spectrum" seems like a "true" action spectrum obtained by the above-described monochromatic irradiation. However, those are completely different; a pseudo action spectrum is an integrated (from longer to shorter wavelengths) form of a "true" action spectrum based on the assumption that light intensity is constant in the whole range of irradiation, because of the difference in irradiation wavelength region (**Fig. 12**). Consequently, the corresponding action spectrum should be estimated by differentiation of the

pseudo action spectrum; a horizontal part in a pseudo action spectrum (**Fig. 12**), if any, shows that apparent quantum efficiency at the wavelength is negligible even if an appreciable value is seen in the pseudo action spectrum.

D. Co-catalyst Loading for Multiple Electron Transfer

As has been discussed in Section II.E, a photocatalytic reaction can proceed if the CB bottom and VB top are more cathodic and anodic than the standard electrode potentials of electron acceptors and donors, respectively. Therefore, band-edge position is very important to predict the possibility for driving a photocatalytic reaction. On the other hand, the gap between the CB bottom and VB top, a band gap, determines the photoabsorption spectrum, i.e., wavelength range to be absorbed by a photocatalyst. For ordinary simple and mixed metal oxides, it has been reported in the 1980's that change in the metal induces a shift of the CB bottom position, while the VB top position is unchanged because the VB is mainly composed of oxygen 2p atomic orbitals commonly contained in metal oxides (42). This means that narrowing the band gap of a metal-oxide photocatalyst shifts the CB bottom position to more anodic, i.e., decreasing the ability of reduction by e^- . In most applications of photocatalysis, molecular oxygen is reduced by e^- , and its standard electrode potential of one-electron reduction of oxygen to give superoxide anion radical ($O_2\cdot^-$) lies just below the CB bottom of anatase titania, absorbing only ultraviolet light. A shift of the absorption range of titania to visible means a shift of the CB bottom below the potential for one-electron reduction of oxygen. The reason for negligible photocatalytic activity of tungsten(VI) oxide (tungstena), absorbing visible light of wavelength up to ca. 470 nm, for oxidative decomposition of organic and inorganic compounds in air is accounted for by the lower CB bottom position. Thus, ordinary metal oxides cannot be a photocatalyst being active for oxidative decomposition under visible-light irradiation (43).

Recently it was reported that loading small amount of platinum onto tungsten(VI) oxide enhances the visible-light photocatalytic activity significantly and this is caused by the catalytic action of platinum to induce multiple-electron transfer to oxygen (44). Reactions of two and four-electron transfer processes are as follows (potential in parentheses is standard electrode potential versus standard hydrogen electrode at pH = 0).

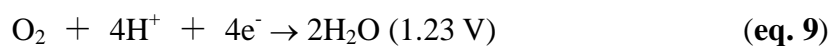
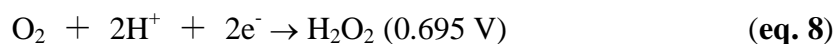

The standard electrode potentials are far more anodic than that of one-electron transfer process, -0.284 V (SHE) and the visible-light photocatalytic activity of platinum-loaded tungsten(VI) oxide could be interpreted by enhanced multiple-electron transfer process by deposited platinum (45), since it is well known that platinum and the other noble metals catalyze such multiple-electron transfer processes. Similar phenomena, co-catalyst promoted visible-light photocatalytic activity, have been reported with palladium (46) and copper oxide (47). Thus, change of reaction process seems beneficial to realize visible-light photocatalytic activity.

V. Design of Active Photocatalysts

A. Physical Property-Activity Correlation

1. Nano-structured Photocatalysts

There have been many reports on preparation of photocatalysts with nanometer-sized structures, e.g., nanoparticles, nanoplates, nanocubes, nanorods, nanotubes or nanowires, as well as their photocatalytic activities, and the number of such reports is still increasing (48). A possible reason for such an explosive increase in studies on nanostructured photocatalysts is popularization of low-priced pressure-tolerant Teflon bottles for hydrothermal reactions. By using this type of apparatus, a variety of inorganic compounds can be prepared and morphology can be changed depending on the reaction conditions. Scanning or transmission electron microscopic images of those nanostructured photocatalysts (even non-photocatalysts) are attractive and interesting. However, considering that we do not know what structural parameters of photocatalysts govern the photocatalytic activity or how they govern the photocatalytic activity, there seems to be no assured reason why nanostructured materials, rather than ordinary non-structured ones, should be employed.

2. Dependence of Photocatalytic Activities on Physical and Structural Properties

It can be said that not only the above-mentioned "nano-structure" but also other

ordinary physical or structural properties measured for photocatalysts have not been proved to be decisive factors for the photocatalytic activities. It is true that photocatalytic activities of photocatalysts of certain components prepared or treated in different ways or under different conditions may be different and this is because physical and structural properties of those photocatalysts differ depending on the preparation/treatment conditions, i.e., physical and structural properties must control the photocatalytic activity (49). A problem is we, at least the author, do not know how properties affect photocatalytic activity. A possible reason is that those properties, though we do not know how many properties are required for analysis, are changed at the same time. For example, when titania photocatalysts are prepared by hydrolysis of a titanium compound such as titanium(IV) sulfate or tetra(2-propoxide) followed by calcination in air, higher-temperature calcination gives higher crystallinity, smaller specific surface area and rutile crystallites, while lower-temperature calcination gives lower crystallinity, larger specific surface area and anatase crystallites. It has been reported that photocatalytic activity of titania particles prepared in such a way decreased drastically at the temperature at which anatase-rutile transformation occurred. Since both crystalline form and specific surface area were changed drastically at the same time and there have been no reported ways to extract the intrinsic effect of each property, it is difficult to determine which property (or both of them) is significant. Discussions on property-activity correlations reported so far, including those reported by a group of the author, may involve such a problem. It can be said that rutile titania samples with a small surface area that are prepared at a high temperature show low photocatalytic activity, but it is scientifically (logically) impossible to state that the conversion of crystalline form or drastic reduction of specific surface area is the reason for the low photocatalytic activity.

3. Extraction of Intrinsic Effects of Physical and Structural Properties

A plausible method to extract the intrinsic effect of each physical and structural property is statistical analysis of data on physical and structural properties and photocatalytic activities for samples of the same composition, such as titania. In a recent study by the author's research group, photocatalytic activities and physical and structural properties of 35 commercial titania powders were statistically analyzed to find the predominant property

(properties) determining the activity of a given reaction system (50): standardized photocatalytic activities for five kinds of reactions were fairly well reproduced by a linear combination of six kinds of physical and structural properties of photocatalysts, i.e., specific surface area, density of crystalline defects, primary particle size, secondary particle size and existence of anatase and rutile phases. Recently, decahedral-shaped anatase-titania particles (DAPs) have been prepared by controlled gas-phase reaction of titanium(IV) chloride and oxygen at 1473 K (**Fig. 13**) (51). The photocatalytic activity of DAPs was reported to be much higher than the photocatalytic activities of commercial titania particles, e.g., Degussa (Evonic) P25, presumably due to relatively large specific surface area to adsorb a large amount of the substrate(s) and high crystallinity, i.e., less crystalline defects to reduce e^-h^+ recombination. Then, how does the decahedral shape itself affect the photocatalytic activity? It was suggested that high levels of photocatalytic activity of DAPs could not be reproduced by correlation equations derived in the above-mentioned multivariable analysis (52).

B. Synergetic Effect

A hypothesis not proved scientifically regarding titania photocatalysts, especially P25, is that the co-presence of anatase and rutile crystallites induces a high level of photocatalytic activity; transfer of photoexcited electrons and positive holes between interconnecting anatase and rutile particles may enhance charge separation and hence improve the efficiency of utilization of electron-hole pairs. However, as far as the author knows, there have been no reports showing direct evidence of such inter-particle charge migrations and the expected lower level of activity of pure anatase or rutile particles alone. In a scientific sense, isolation of anatase and rutile crystallites from P25 is necessary to determine the crystalline composition and to check the synergetic effect of anatase and rutile.

The term "synergetic effect" in photocatalysis could be defined as follows: when more than two kinds of photocatalysts are used as a mixture, the overall photocatalytic activity exceeds the sum of activities of each photocatalyst (**Fig. 14**). When a certain component alone is not a photocatalyst and a mixture with another photocatalyst shows improved activity, that component should be called "co-catalyst" or "enhancer", and the

improvement cannot be attributed to a synergetic effect. One of the representative discussions on the synergetic effect is for anatase-rutile mixed crystalline photocatalysts, such as Degussa P25 (53). The author thinks that a synergetic effect has not yet been proved for P25, and the effect seems to be speculation. This is natural considering that each component, anatase and rutile, in P25 had not been isolated before the isolation of anatase by the author's group. Even if all of the components are isolated from the mixture, how can we show a synergetic effect? Taking into consideration the fact that a photocatalytic reaction proceeds by photoabsorption of the photocatalyst and the fact that total number of absorbed photons is not directly proportional to the mass (volume) of the photocatalyst, a control experiment using each component should be carried out with adjustment to make the flux of absorbed photons the same as that for the mixture. However, discussion is still needed to establish a method to clarify the synergetic effect in photocatalysis.

VII. Concluding Remarks

When the author started the study on photocatalysis in 1981, there appeared to be no laboratories doing research work only on photocatalysis, i.e., photocatalysis studies were preformed in laboratories in the field of catalysis, electrochemistry, photochemistry, materials chemistry, etc. This means that results of those studies have been discussed, presumably, on the basis of different concepts, analytical methods or understanding depending on the fields, and this might give rise to misunderstandings, misconceptions or speculations, some of which are described in this review. It is time now to fix the field of "photocatalysis" having common unified understandings. It would be the author's great pleasure if this review builds a momentum for unified understandings of photocatalysis.

Acknowledgments

This work was partly supported by Project to Create Photocatalyst Industry for Recycling-oriented Society supported by NEDO, New Energy and Industrial Technology Development Organization and Grant-in-Aid for "Scientific Research (A) (General)" from the Ministry of Education, Culture, Sports, Science and Technology (MEXT) of Japan.

References and notes

- (1) Fujishima, A.; Hashimoto, K.; Watanabe, T. In "TiO₂ PHOTOCATALYSIS Fundamentals and Applications, Bkc, Inc. Tokyo, 1999.
- (2) Hoffmann, M. R.; Martin, S. T.; Choi, W. Y. *Chem. Rev.* **1995**, *95*, 69.
- (3) (a) Fujishima, A.; Zhang, X. T.; Tryk, D. A. *Surf. Sci. Rep.* **2008**, *63*, 515. (b) Fujishima, A.; Zhang, X.; Tryk, D. A. *Int. J. Hydrogen Energy* **2007**, *32*, 2664.
- (4) Ohtani, B. *Chem. Lett.* **2008**, *37*, 216.
- (5) Papers reporting activation energy of photocatalytic reactions in the period 2000–2004. Figures and compounds in square brackets and parentheses, respectively, show activation energy in the unit of kJ mol⁻¹ and substrate. (a) Vorontsov, A. V.; Stoyanova, I. V.; Kozlov, D. V.; Simagina, V. I.; Savinov, E. N. *J. Catal.* **2000**, *189*, 360. [10.9 (acetone)] (b) Xu, Y. M. *Chem. J. Chin. Univ. Chin.* **2000**, *21*, 1539. [4.2-4.6 (acetophenone)] (c) Su, W. Y.; Fu, X. Z.; Wei, K. M. *Chem. J. Chin. Univ. Chin.* **2001**, *22*, 272. [13.7 (bromomethane)] (d) Lea, J.; Adesina, A. A. *J. Chem. Tech. Biotech.* **2001**, *76*, 803. [7.83 (nitrophenol)] (e) Kartal, O. E.; Erol, M.; Oguz, H. *Chem. Eng. Tech.* **2001**, *24*, 645. [16.2 (phenol)] (f) Okte, A. N.; Resat, M. S.; Inel, Y. *J. Catal.* **2001**, *198*, 172. [17.1 (1,3-dihydroxy-5-methoxybenzene)] (g) Tada, H.; Suzuki, F.; Yoneda, S.; Ito, S.; Kobayashi, H. *Phys. Chem. Chem. Phys.* **2001**, *3*, 1376. [19.7/29.4 (bis(2-dipyridil)disulfide)] (h) Lee, N. C.; Choi, W. Y. *J. Phys. Chem. B* **2002**, *106*, 11818. [18.7 (soot)] (i) Cui, W. Q.; Feng, L. R.; Xu, C. H.; Lu, S. J.; Qiu, F. *Chin. J. Catal.* **2003**, *24*, 937. [8.46 (methanol)] (j) Kozlov, D. V.; Panchenko, A. A.; Bavykin, D. V.; Savinov, E. N.; Smirniotis, P. G. *Russ. Chem. Bull.* **2003**, *52*, 1100. [6.3 ± 0.4 (benzene)] (k) Mills, A.; Hill, G.; Bhopal, S.; Parkin, I. P.; O'Neill, S. A. *J. Photochem. Photobiol. A Chem.* **2003**, *160*, 185. [19 (stearic acid)] (l) Al-Rasheed, R.; Cardin, D. J. *Chemosphere* **2003**, *51*, 925. [17 ± 0.6 (fumic acid)] (m) Garcia, J. C.; Takashima, K. *J. Photochem. Photobiol. A Chem.* **2003**, *155*, 215. [24.8 (imazaquin)] (n) Machado, A. E. H.; de Miranda, J. A.; de Freitas, R. F.;

- Duarte, E. T. F. M.; Ferreira, L. F.; Albuquerque, Y. D. T.; Ruggiero, R.; Sattler, C.; de Oliveira, L. *J. Photochem. Photobiol. A Chem.* **2003**, *155*, 231. [7.9–10.5 (organic matter)] (o) Parra, S.; Stanca, S. E.; Guasaquillo, I.; Thampi, K. R. *Appl. Catal. B: Environ.* **2004**, *51*, 107. [10.9 (atrazine)]
- (6) Fujishima, A.; Honda, K. *Nature* **1972**, *238*, 37. "Honda-Fujishima effect" is a well-known chemical phenomenon closely related to photocatalysis and the paper published in *Nature* in 1972 had undoubtedly promoted research activity of photocatalysis but not an origin of heterogeneous photocatalysis in the bibliographic sense (Ref. 3(a)).
- (7) Sometimes the term "active site" is used for a photocatalytic reaction system with dispersed chemical species, e.g., metal complexes or atomically adsorbed species, on support materials. Even in this case, a photocatalytic reaction occurs only when the species absorb light, and species not irradiated therefore cannot be active sites.
- (8) (a) Kowalska, E.; Abe, R.; Ohtani, B. *Chem. Commun.* **2009**, *45*, 241. (b) Kowalska, E.; Prieto-Mahaney, O. O.; Abe, R.; Ohtani, B. *Phys. Chem. Chem. Phys.* **2010**, *12*, 2344. (c) Zielinska, A.; Kowalska, E.; Sobczak, J. W.; Izabela, L.; Gazda, M.; Ohtani, B.; Hupka, J.; Zaleska, A. *Separ. Purif. Tech.* **2010**, *72*, 309.
- (9) In femto-second pump-probe transition photoabsorption measurements, titania photocatalysts gave visible-light photoabsorption of trapped e^- within ca. 100 fs pump pulse without showing photoabsorption of e^- in the CB. See Section III.C.
- (10) (a) Ikeda, S.; Sugiyama, N.; Murakami, S.-y.; Kominami, H.; Kera, Y.; Noguchi, H.; Uosaki, K.; Torimoto, T.; Ohtani, B. *Phys. Chem. Chem. Phys.* **2003**, *5*, 778-783. (b) Murakami, N.; Prieto-Mahaney, O. O.; Abe, R.; Torimoto, T.; Ohtani, B. *J. Phys. Chem. C* **2007**, *111*, 11927-11935.
- (11) A probable first report on photocatalytic liberation of hydroxyl radical: Jaeger, C. D.; Bard, A. J. *J. Phys. Chem.* **1979**, *83*, 3146.
- (12) Recent papers on photocatalytic production of hydroxyl radical: (a) Hirakawa, T.; Nosaka, Y. *Langmuir* **2002**, *18*, 3247. (b) Nosaka, Y.; Komori, S.; Yawata, K.;

Hirakawa, T.; Nosaka, A. Y. *Phys. Chem. Chem. Phys.*, **2002**, *5*, 4731. (c) Tryba, B.; Toyoda, M.; Morawski, A. W.; Nonaka, R.; Inagaki, M. *Appl. Catal. B Environ.* **2007**, *71*, 163. (d) Murakami, Y.; Endo, K.; Ohta, I.; Nosaka, Y. *J. Phys. Chem.* **2007**, *111*, 11339. (e) Hirakawa, T.; Yawata, K.; Nosaka, Y. *Appl. Catal. A Gen.* **2007**, *325*, 105. (f) Sroiraya, S.; Triampo, W.; Morales, N. P.; Triampo, D. *J. Ceram. Proc. Res.* **2008**, *9*, 146. (g) Chang, C. Y.; Hsieh, Y. H.; Hsieh, L. L.; Yao, K. S.; Cheng, T. C. *J. Hazard. Mater.* **2009**, *166*, 897, and references therein.

- (13) Since the band structure of semiconductors, as well as insulators, consists of a filled valence band (VB) and vacant conduction band (CB), their Fermi level must be located between the VB and CB.
- (14) Backward electron (hole) transfer can be avoided thermodynamically only when the CB bottom and VB top are more positive and negative than standard electrode potentials of a reductant and an oxidant, respectively.
- (15) In other words, it is impossible to discuss "energy conversion efficiency" for reaction of negative Gibbs energy change as shown in **Fig. 5 (b)**.
- (16) It is thought that there should be at least ca. 200-mV "overpotential" in both reduction by e^- and oxidation by h^+ , and this shifts the limiting wavelength for water splitting by ca. 250 nm.
- (17) In this analysis of first-order kinetics, any value can be plotted against time of reaction, unless the value is proportional to the molar amount of a substrate or product; for example, absorbance of a compound at a given wavelength can be used even if the molar absorption (extinction) coefficient is unknown and thereby absolute concentration can not be determined. Moreover, taking the logarithm means a reciprocal value can also be used, e.g., $[A_0]/[A]$, where $[A_0]$ is initial concentration of a substrate A (See **Fig. 6**).
- (18) Under these conditions, rate constant k obtained by the first-order kinetic analysis does not reflect the reactivity of a photocatalyst; k contains diffusion constant of a substrate and surface area of a substrate (strictly speaking, area of the diffusion layer on the

"photoirradiated active" surface).

- (19) It should be noted that the overall rate obeys the first-order rate law in regard to surface concentration of a substrate but not concentration in the bulk.
- (20) In the lower concentration region of a Langmuir adsorption isotherm, similar linear dependence is also observed. However, if a given reaction condition is considered to be in this region, a Henry-type adsorption isotherm, not a Langmuir-type one, should be used, since the most significant characteristic of a Langmuir isotherm is saturation at a high concentration.
- (21) Another point to check is adequate use of substrate concentration in analysis. Since a Langmuir isotherm is derived on the basis of the adsorption equilibrium between species adsorbed and desorbed in solution, the isotherm is a function of concentration of the adsorbate (molecules to be adsorbed on surfaces) in solution, not concentration of the adsorbate in feed. Therefore, the actual concentration, which must be reduced from that in feed due to appreciable adsorption, must be measured at least before photoirradiation.
- (22) The author thinks that the use of "rate-determining step" for photoreactions is misleading, since a photoreaction in principle proceeds via species in their excited state and they undergo both chemical reaction and deactivation (deexcitation). The assumption for rate-determining step is that the reaction proceeds sequentially, not in parallel, such as photoreactions. See Section III.E.
- (23) In some reports on photocatalytic reaction, it has been stated that the time-course curve obeys the first-order rate law and that the rate of reaction changes following Langmuir-type adsorption behavior (so-called "Langmuir-Hinshelwood mechanism") when the substrate concentration is changed, though these two facts are incompatible. A possible situation is that a double reciprocal plot of rate and substrate concentration (**Fig. 7 (a)**) is linear but that the line passes through the origin, suggesting that the rate is proportional to the substrate concentration.
- (24) An example of papers showing the coincidence of equilibrium adsorption constants

- obtained from the photocatalytic reaction rate and adsorption in the dark, see: Amano, F.; Nogami, K.; Ohtani, B. *Langmuir* **2010**, *26*, 7174. Examples of papers reporting adsorption in the dark are as follows: (a) Cunningham, J.; Sedlak, P. J. *Photochem. Photobiol. A: Chem.* **1994**, *77*, 255. (b) Minero, C. *Catal. Today*, **1999**, *54*, 205. (c) Xu, Y.; Langford, C.H. *J. Photochem. Photobiol. A: Chem.* **2000**, *133*, 67.
- (25) (a) Colombo, Jr., D. P.; Bowman, R. M. *J. Phys. Chem.* **1995**, *99*, 11752. (b) Colombo, Jr., D. P.; Bowman, R. M. *J. Phys. Chem.* **1996**, *100*, 18445. (c) Colombo, Jr., D. P.; Roussel, K. A.; Saeh, J.; Skinner, D. E.; Cavaleri, J. J.; Bowman, R. M. *Chem. Phys. Lett.* **1995**, *232*, 207.
- (26) Ohtani, B.; Kominami, H.; Bowman, R.M.; Colombo Jr., D. P.; Noguchi, H.; Uosaki, K. *Chem. Lett.* **1998**, *27*, 579.
- (27) Tamaki, Y.; Hara, K.; Katoh, R.; Tachiya, M.; Furube, A. *J. Phys. Chem. C* **2009**, *113*, 11741.
- (28) This stoichiometry was clarified for the first time by the author's group and reported as Nishimoto, S.-i.; Ohtani, B.; Kajiwara, H.; Kagiya, T. *J. Chem. Soc., Faraday Trans.1* **1983**, *79*, 2685. Before submission to this journal, we submitted a part of the experimental results to Chemistry Letters as the first paper in the author's career in the field of photocatalysis, but the paper was rejected presumably due to a reviewer's comment that the content had been reported in a Russian journal without showing bibliographic data (We could not find this.). To submit the results as a full paper, additional experiments were carried out to support the stoichiometry. For example, an oxygen-isotope experiment was performed and showed the origin of molecular oxygen to be water. As a result, we were able to have the paper published, and it has been cited more than 100 times, including recent citations. This is an example of rejection of a submitted paper not always being disadvantageous for the authors.
- (29) This small content of ultraviolet light in solar radiation has been often described in papers, but an explanation of how this content was determined is rare. See Ref. 4, but the calculation in this review included some mistakes.

- (30) In the Japanese Industrial Standards (JIS B7113, discontinued), limiting transmission wavelength is defined as the center of wavelengths giving 72% and 5% transmission. For example, the limiting transmission wavelength for an Asahi Technoglass L-42 cut-off filter is 420 nm based on the standard, and this filter transmits ca. 60% at 420 nm. The number "42" indicates only that 420 nm is the limiting transmission wavelength defined in JIS, and a sample is practically irradiated at > 390 nm through this filter. Statements such as "visible-light irradiation at > 420 nm was performed using an optical sharp cut filter" seem misleading when L-42 has been used.
- (31) Asahi, R.; Morikawa, T.; Ohwaki, T.; Aoki, K.; Taga, Y. *Science* **2001**, *293*, 269. Fifteen years before the publication of this paper, Sato had reported the nitrogen incorporation in titania lattice, but he reported this to be "NO_x doping"; Sato, S. *Chem. Phys. Lett.* **1986**, *123*, 126.
- (32) Amano, F.; Abe, R.; Ohtani, B. *Trans. Mater. Res. Soc. Jpn.* **2008**, *33*, 173.
- (33) Highfield, J.G.; Pichat P. *New J. Chem.* **1989**, *13*, 61.
- (34) (a) Mitoraj, D.; Beranek, R.; Kisch, H. *Photochem. Photobiol. Sci.* **2010**, *9*, 31. (b) Mitoraj, D.; Kisch, H. *Chem. Euro. J.* **2010**, *16*, 261.
- (35) Yan, X.; Ohno, T.; Nishijima, K.; Abe, R.; Ohtani, B. *Chem. Phys. Lett.* **2006**, *429*, 606. This paper claimed inappropriate use of organic dyes as test compounds for visible light-sensitive photocatalysts. Citation of this paper was not expected at all, since the authors using methylene blue (MB) as a model compound for photocatalytic reaction never want to refer to this and, on the other hand, those who do not use MB need not to refer to this. However, there has been an appreciable number of citations and, to the author's surprise, approximately half of the citations of this paper were for reasonable use of MB, indicating that authors of those papers did not read the paper.
- (36) Watanabe et al. have reported similar action spectrum analysis of photoinduced degradation of Rhodamine B with a cadmium sulfide suspension and pointed out a similar dye-sensitization mechanism: Watanabe, T.; Takizawa, T.; Honda, K. *J. Phys. Chem.* **1977**, *81*, 1845. Photocatalytic reaction of MB in aerated titania suspensions

was reported in 1937 by a Japanese photochemist: Horio, M. *Nihon Gakujutsu Kyokai Hokoku* **1937**, *12*, 204 (in Japanese). As far as the author knows, this is the first report on titania photocatalysis.

- (37) Mills, A.; Wang, J. *J. Photochem. Photobiol. A: Chem.* **1999**, *127*, 123.
- (38) The fact that irradiation of a dye solution in the absence of a photocatalyst decomposes the dye negligibly has often been described in the papers to support negligible photoinduced reaction by photoexcited dye molecules. However, the photoinduced electron injection requires an acceptor, such as titania, and thereby there are no ideal control experiments to exclude the possibility of photoinduced electron injection, as shown in **Fig. 11**.
- (39) When organic dyes themselves are a pollutant to be decomposed, visible light-induced, but not photocatalytic, reaction can be a useful technique, e.g., Chen, X.; Zheng, Z.; Ke, X., Jaatinen, E.; Xie, T.; Wang, D.; Guo, C.; Zhao, J.; Zhu, H., *Green Chem.* **2010**, *12*, 414.
- (40) Torimoto, T.; Aburakawa, Y.; Kawahara, Y.; Ikeda, S.; Ohtani, B. *Chem. Phys. Lett.* **2004**, *392*, 220. This paper showed that the rate of photocatalytic reaction in the presence of molecular oxygen, i.e., photocatalytic oxidative decomposition, may strongly depend on the intensity of light irradiation, while the rate of reaction in the absence of oxygen seems to be almost independent of light intensity.
- (41) Strictly speaking, when apparent quantum efficiency is discussed, the light intensity should be adjusted to be the same in number of photons, not in energy.
- (42) Scaife, D. E. *Solar Energy*, **1980**, *25*, 41.
- (43) Some exceptions have been reported, e.g., bismuth tungstate (Bi_2WO_6) shows a relatively high level of photocatalytic activity for oxidative decomposition of acetaldehyde in air: (a) Amano, F.; Nogami, K.; Ohtani, B. *J. Phys. Chem. C* **2009**, *113*, 1536. (b) Amano, F.; Nogami, K.; Abe, R.; Ohtani, B. *J. Phys. Chem. C* **2008**, *112*, 9320-9326.
- (44) Abe, R.; Takami, H.; Murakami, N.; Ohtani, B. *J. Am. Chem. Soc.* **2008**, *130*, 7780.

- (45) It was proved that tungsten(VI) oxide produces a negligible amount of hydrogen from an aqueous solution containing electron donors such as methanol even when loaded with platinum, and this is consistent with the assumption of platinum-catalyzed multiple-electron transfer to oxygen.
- (46) Arai, T.; Horiguchi, M.; Yanagida, M.; Gunji, T.; Sugihara, H.; Sayama, K. *Chem. Commun.* **2008**, 5565.
- (47) Irie, H.; Kamiya, K.; Shibamura, T.; Miura, S.; Tryk, D. A.; Yokoyama, T.; Hashimoto, K. *J. Phys. Chem. C* **2009**, *113*, 10761.
- (48) A recent review on nanostructured titania photocatalysts: Chen, X.; Mao, S. S. *Chem. Rev.* **2007**, *107*, 2891.
- (49) Examples of papers discussing the property-activity correlation are: (a) Enríquez, Rosario; Agriosa, A.G.; Pichat, P. *Catal. Today*, **2007**, *120*, 196. (b) Ryu, J.; Choi, W. *Environ. Sci. Technol.* **2008**, *42*, 294.
- (50) (a) Prieto-Mahaney, O.O.; Murakami, N.; Abe, R.; Ohtani, B., *Chem. Lett.* **2009**, *38*, 238. (b) Ohtani, B.; Prieto-Mahaney, O. O.; Amano, F.; Murakami, N.; Abe, R. *J. Adv. Oxidat. Tech.* **2010**, *13*, 247.
- (51) Amano, F.; Prieto-Mahaney, O. O.; Terada, Y.; Yasumoto, T.; Shibayama, T.; Ohtani, B. *Chem. Mater.* **2009**, *21*, 2601.
- (52) Ohtani, B.; Amano, F.; Yasumoto, T.; Prieto-Mahaney, O. O.; Uchida, S.; Shibayama, T.; Terada, Y. *Top. Catal.* **2010**, *53*, 455.
- (53) It was suggested that transfer of photoexcited electrons and positive holes between interconnecting anatase and rutile particles may enhance charge separation and hence improve the efficiency of utilization of electron-hole pairs: Hurum, D.C.; Agrios, A.G.; Gray, K.A.; Rajh, T.; Thurnauer, C. *J. Phys. Chem. B* **2003**, *107*, 4545. On the other hand, the author of this article has published a paper suggesting no synergetic effect of anatase and rutile in P25: Ohtani, B.; Prieto-Mahaney, O. O.; Li, D.; Abe, R. *J. Photochem. Photobiol. A Chem.* **2010**, *216*, 179.

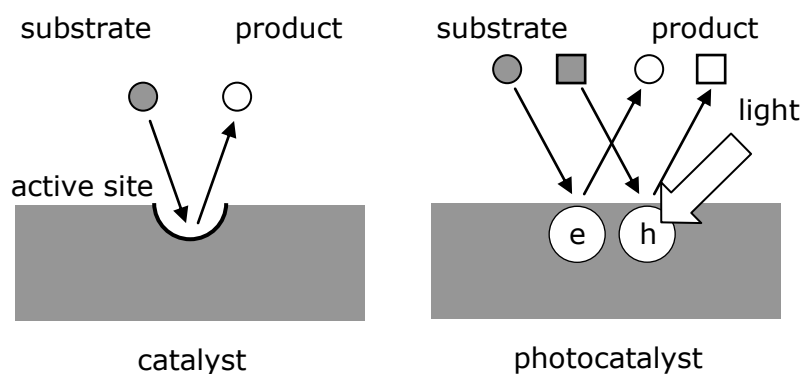

Fig. 1 Difference in concepts of catalytic and photocatalytic reactions: A catalyst contains active sites at which a substrate is converted into a product, while no active sites are present on a photocatalyst.

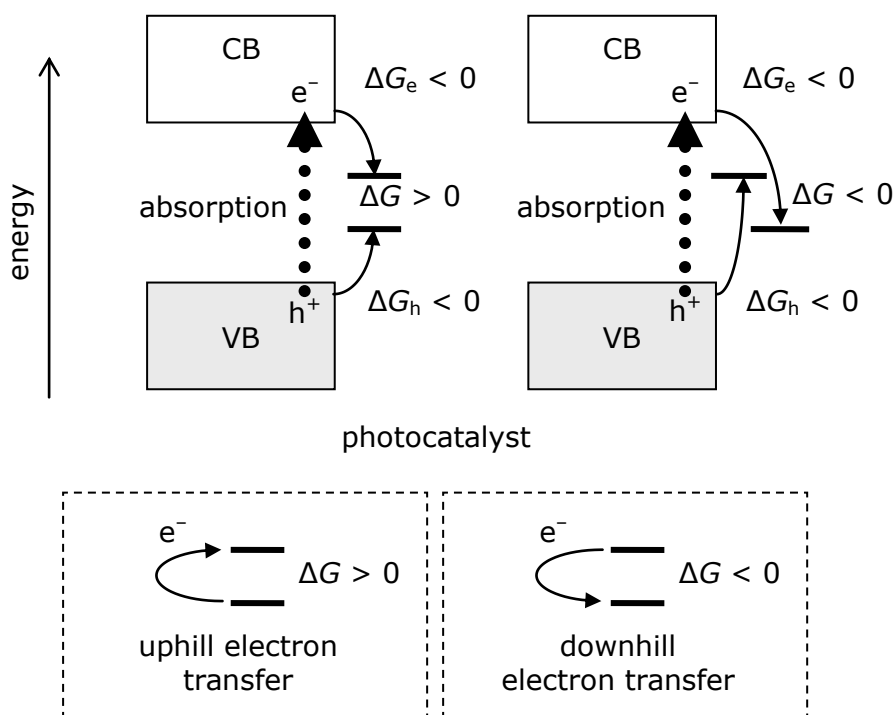

Fig. 2 Gibbs-energy change in photocatalytic reactions.

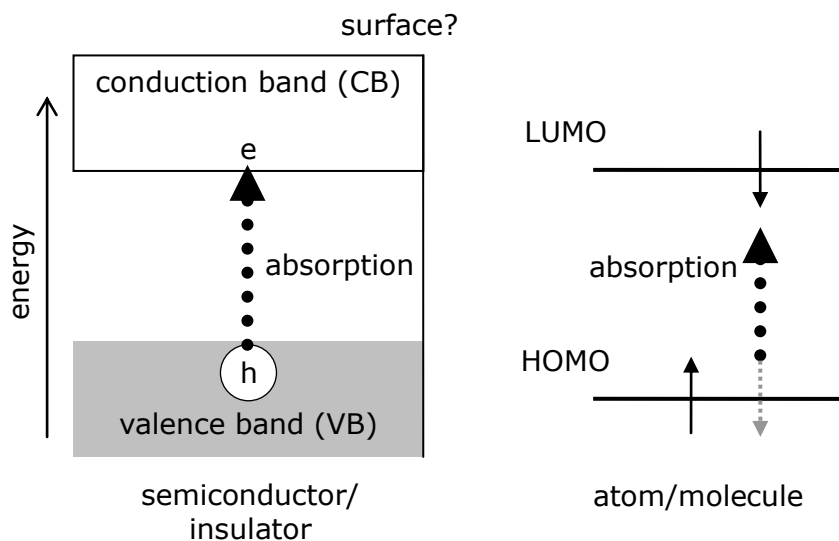

Fig. 3 Photoabsorption by transition of electrons in the VB or HOMO to the CB or LUMO in a semiconductor/insulator or atom/molecule, respectively.

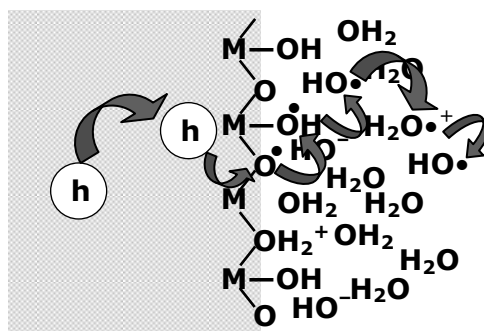

Fig. 4 Transfer of positive holes from bulk of a photocatalyst through the interface to aqueous solution phase. Surface-adsorbed and free (hydrated) hydroxyl radicals and its derivatives can be a possible form of positive holes.

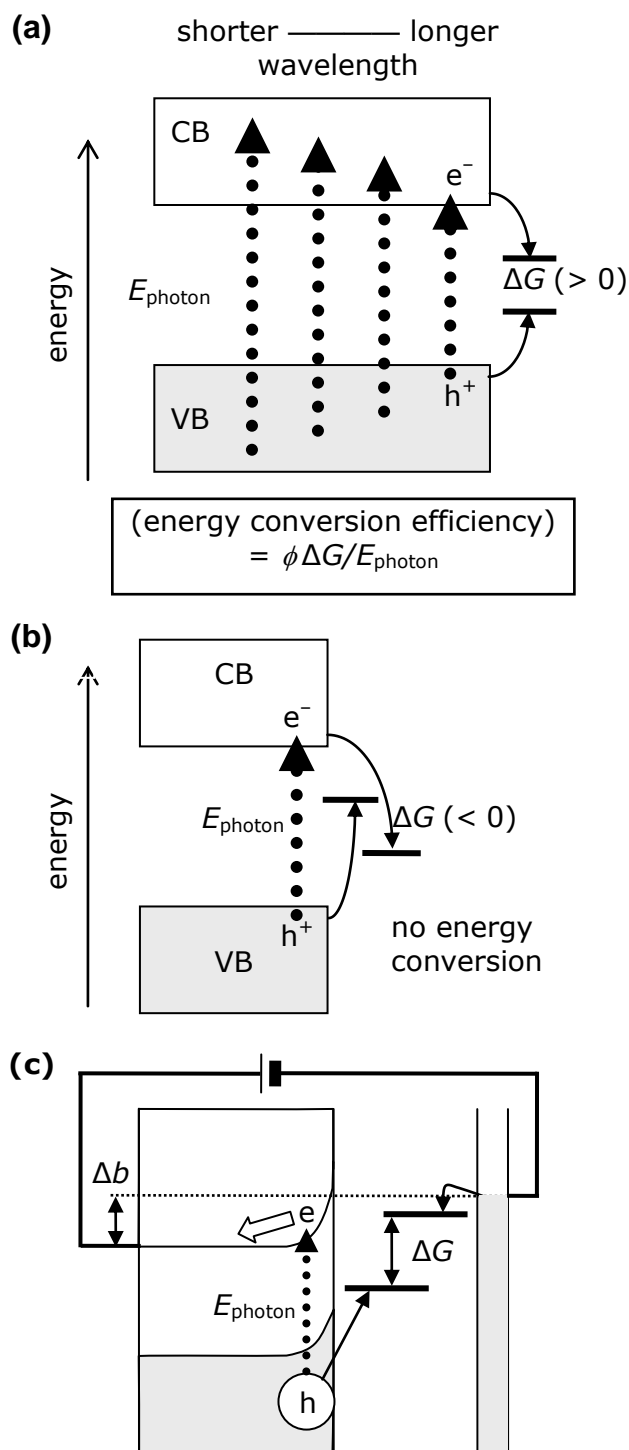

Fig. 5 (a) Photo-to-chemical energy conversion efficiency of photocatalytic reaction calculated as an integral of the product of apparent quantum efficiency (ϕ) and Gibbs energy change (storage) divided by photon energy (E_{photon}) as a function of wavelength. (b) In the case where Gibbs energy change is negative, energy conversion efficiency can not be defined, or is defined to be zero. (c) Electrochemically biased (Δb) photoelectrochemical cell consisting of an n-type semiconductor and metal counter electrodes.

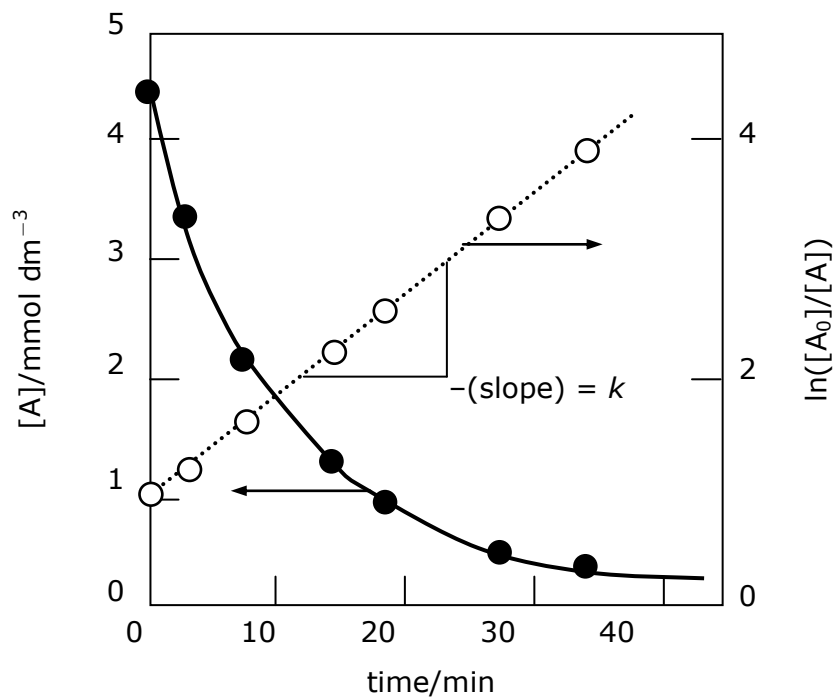

Fig. 6 First-order kinetic analysis for a reaction consuming a substrate A. Plot of logarithm of relative consumption (in the present plot, ratio of initial concentration of substrate A and concentration of A at a given time).

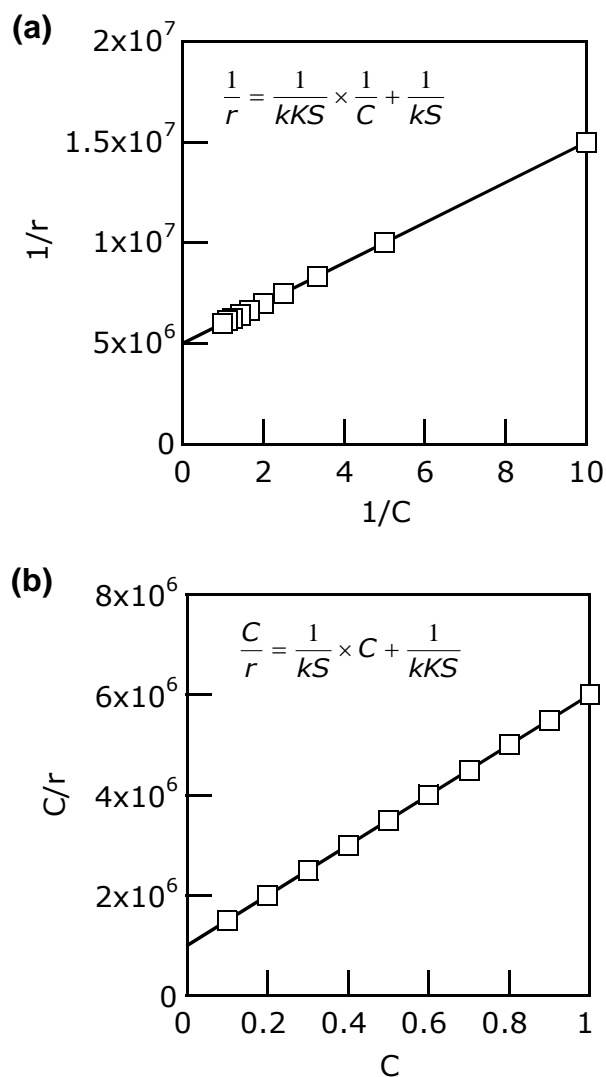

Fig. 7 Simulation of linearized plots for kinetics governed by surface concentration of substrates adsorbed on the photocatalyst surface in a Langmuirian fashion, where r , C , k , K and S are rate of reaction (mol s^{-1}), concentration of a substrate (mol L^{-1}), rate constant (10^{-4} s^{-1}), adsorption equilibrium constant (5 L mol^{-1}) and saturated amount of adsorption ($2 \times 10^{-3} \text{ mol}$).

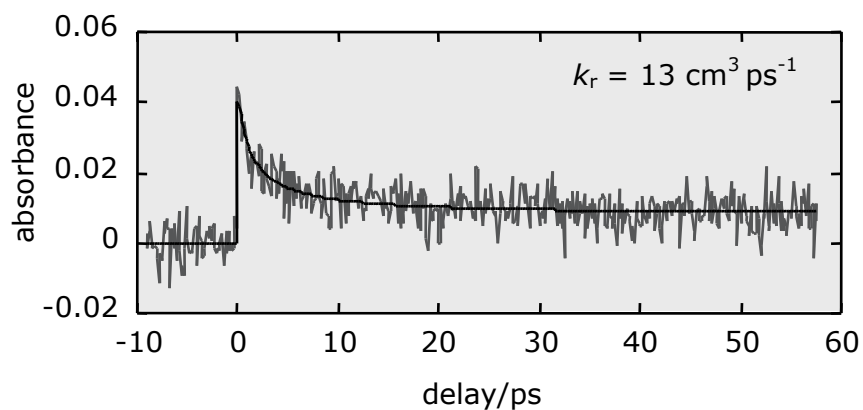

Fig. 8 An example of picosecond-time-region decay of photoabsorption (620 nm) of trapped electrons in Degussa (Evonic) P25 particles after excitation by a ca. 100-fs pump pulse (310 nm). The curve was analyzed by a second-order rate law (eq. 4) with a baseline component (BL), and a second-order rate constant (k_r) was obtained to be $13 \text{ cm}^{-1} \text{ ps}^{-1}$.

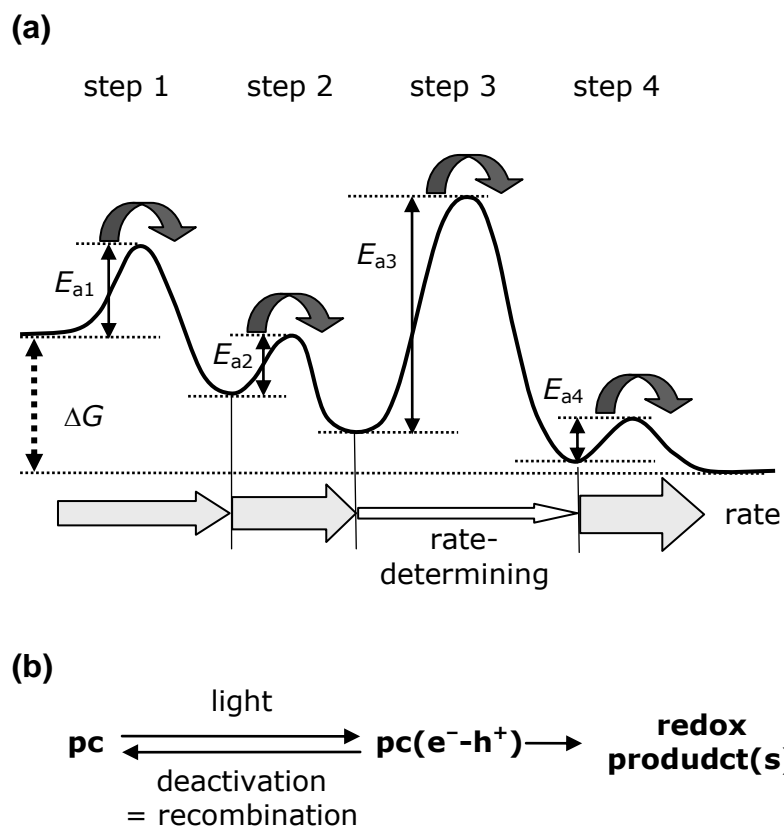

Fig. 9 (a) Model interpreting a rate-determining step in a 4-step series reaction. Step 3 with largest activation energy determines the overall rate. (b) Simplified scheme of photocatalytic reaction with a photocatalyst "pc". It is clear that this process is not a series reaction since a "deactivation step" is included.

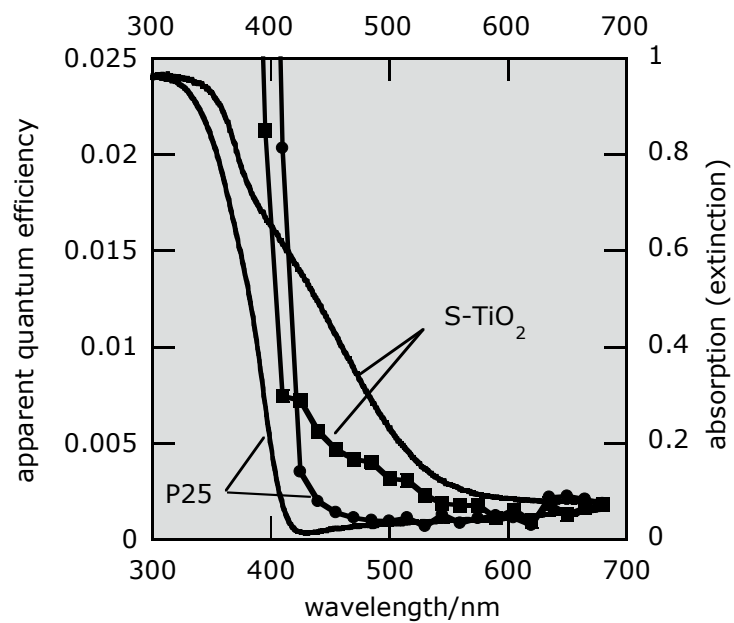

Fig. 10 Diffuse reflectance (photoabsorption) and action spectra for acetic acid, having no absorption in the visible-light wavelength range, decomposition in aerated aqueous solutions of sulfur-doped titania (S-TiO₂) and Degussa (Evonic) P25.

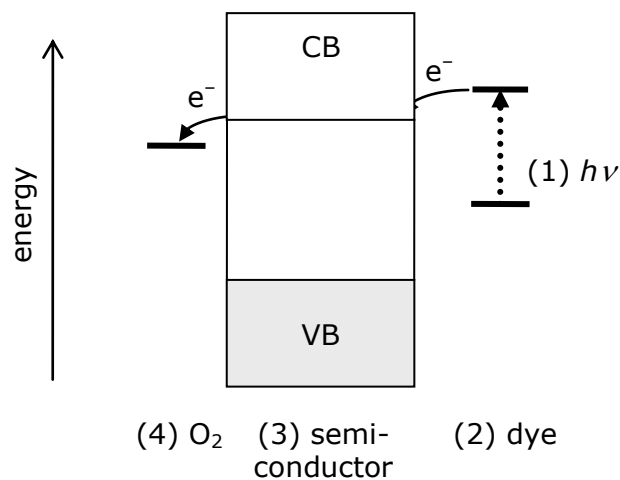

Fig. 11 Possible mechanism of "dye-sensitized" photoinduced oxidative decomposition of dye in the presence of oxygen. Components (1)–(4) are necessary conditions for "dye-sensitized reaction" and they are also necessary conditions for ordinary photocatalytic reaction.

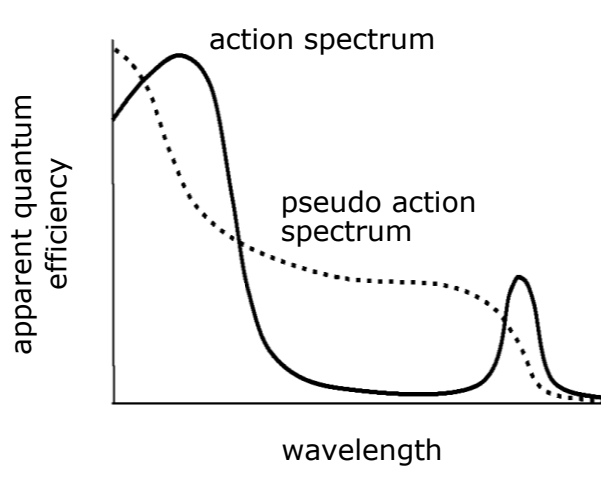
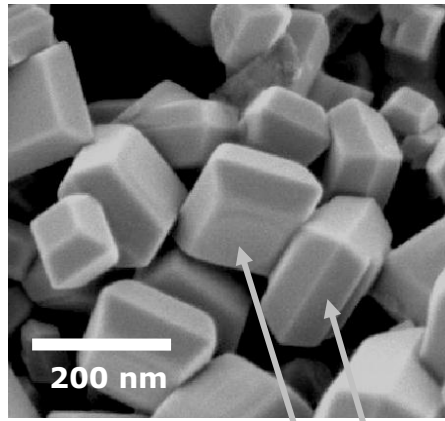

Fig. 12 Examples of action and pseudo action spectra for photoinduced reaction by an ordinary semiconductor photocatalyst (shorter wavelength) and an organic dye (longer wavelength peak). A pseudo action spectrum taken by cut-off filters corresponds to integration of the "true" action spectrum from the longer-wavelength side.



(001) (101)

Fig. 13 A representative SEM image of decahedral anatase-titania particles prepared by controlled gas-phase reaction of titanium(IV) chloride and oxygen at 1473 K. Most particles expose two square (001) facets and eight trapezoidal (101) facets.

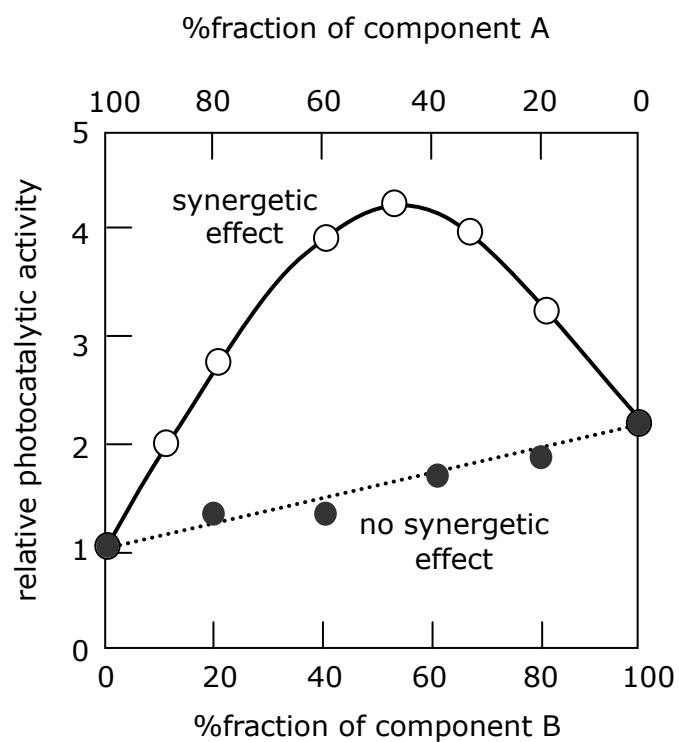

Fig. 14 Hypothetical representation of relative photocatalytic activities of mixtures of components A and B. A synergetic effect can be suggested at least when a mixture shows better photocatalytic activity compared with those of pure components A and B.