



Title	Current tunable current-mode biquadratic filter using dual-output current followers
Author(s)	Bunruang, Kritsada; Prasertsom, Danucha; Pukkalanun, Tattaya; Tangsrirat, Worapong
Citation	Proceedings : APSIPA ASC 2009 : Asia-Pacific Signal and Information Processing Association, 2009 Annual Summit and Conference, 315-318
Issue Date	2009-10-04
Doc URL	http://hdl.handle.net/2115/39700
Type	proceedings
Note	APSIPA ASC 2009: Asia-Pacific Signal and Information Processing Association, 2009 Annual Summit and Conference. 4-7 October 2009. Sapporo, Japan. Poster session: Advanced Circuits and Systems/VLSI (5 October 2009).
File Information	MP-P3-10.pdf



[Instructions for use](#)

Current tunable current-mode biquadratic filter using dual-output current followers

Kritsada Bunruang* Danucha Prasertsom† Tattaya Pukkalanun* and Worapong Tangsrirat*

*Department of Control Engineering, Faculty of Engineering,
King Mongkut's Institute of Technology Ladkrabang (KMITL), Ladkrabang, Bangkok 10520, Thailand
E-mail: bu_kritsada@hotmail.com, ktworapo@kmitl.ac.th, Tel/Fax +66-2-326-4205

†Department of Electrical Engineering, Faculty of Engineering,
King Mongkut's University of Technology North-Bangkok (KMUTNB), Bangsue, Bangkok 10800, Thailand
E-mail: danuchap@kmutnb.ac.th, Tel/Fax +668-5-834-6002

Abstract— This paper describes a current-mode multifunction filter with a minimum number of active and passive elements using dual-output current followers (DO-CFs) as active elements. By based on the dual-output current-controlled current conveyor (DO-CCCII)-based current followers, the proposed filter consists of only two DO-CFs and two grounded capacitor, without an external passive resistor requirement. The filter can realize all the standard biquadratic functions without changing the circuit configuration. Moreover, its natural angular frequency and bandwidth is controllable independently and electronically by adjusting an external bias current, and its active and passive sensitivities are low.

I. INTRODUCTION

It is well known that a universal biquadratic filter is a very useful second-order function block which is widely used in various parts, such as communication and measuring systems. It may be employed in phase locked loop FM stereo demodulator, touch tone telephone and cross over networks used in three-way high fidelity loudspeakers [1]

Because of the well known advantages of low power dissipation and high frequency operation, the design and implementation of current-mode active filters using unity gain cells, i.e. voltage follower (VF) and current follower (CF), have received considerable attention [2]-[3]. From the point of view of the active sensitivity, the use of only CFs as active elements has a dominant advantage, i.e., it can avoid the active sensitivity problems caused by the voltage tracking error. Due to the above reasons, it is beneficial to use CFs as basic active building blocks to realize various current-mode active filters. As a result, numerous realizations of current-mode biquadratic filters using CFs have thus been previously reported [2]-[7]. However, all of these realizations have at least one of the following inconveniencies.

- 1) The lack of electronic adjustability [2]-[7].
- 2) They need a large number of active and passive components [2]-[4], [6]-[7].
- 3) The use of some passive resistors [2]-[7].
- 4) Several cancellation constraints are required [2]-[6].
- 5) The outputs of the filter responses are not in high output impedance [2], [5].

On the other hand, by the introduction of the second-

generation current-controlled conveyor (CCCII) in active filter designs [8], new advantageous filter topologies could be realized and extended to the domain of electronically tunable functions. The electronic adjustability of the CCCII is attributed to the dependence of the parasitic resistance at port x (R_x) on an external bias current of the conveyor, yielding wider tuning range [9]. Moreover, minimizing the number of active and passive components provides the obvious advantages of low cost and power dissipation. Considering these facts, we propose a new three-input single-output current-mode universal biquadratic filter which uses two dual-output current followers (DO-CFs) as active elements together with two grounded capacitors. In this work, the DO-CF operation is implemented by means of the dual-output current-controlled conveyor (DO-CCCII) with its high-impedance y-terminal grounded. The proposed filter not only employs a minimum number of active and passive components, but also offers the main advantages of an independent electronic control of the important filter parameters and the absence of the external passive resistors. By appropriately selecting the input signals, the filter can realize all the five standard types of biquadratic functions, i.e., lowpass (LP), bandpass (BP), highpass (HP), bandstop (BS), and allpass (AP), all at a high impedance output which enables easy cascading in current-mode. Furthermore, the filter does not require any passive parameter matching conditions, and its active and passive sensitivities can be kept smaller than unity in magnitude. The proposed filter has been simulated with PSPICE program to verify the theoretical analysis

II. DUAL-OUTPUT CURRENT FOLLOWER (DO-CF)

The DO-CF, whose electrical symbol is shown in Fig.1, is an input-grounded active component with terminal characteristics described by the following set of equations.

$$v_x = 0 \quad , \quad i_{z+} = +i_x \quad \text{and} \quad i_{z-} = -i_x \quad (1)$$

where the plus and minus signs of the i_z represent the positive and negative current conveyance from x to +z and -z terminals, respectively.

Obviously, the DO-CF can be implemented using several techniques and different types of active building blocks. However, in this work, to enable the flexible design and to avoid the use of many passive components, the DO-CCCII with its y-terminal grounded is employed to realize the DO-CF.

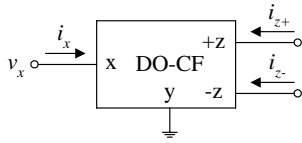

Figure 1 : Electrical symbol of the DO-CF

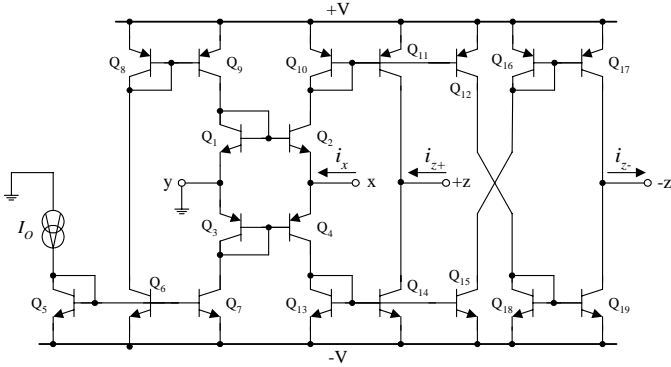

Figure 2 : The realization of the DO-CF using the DO-CCCII with its y-terminal connected to ground.

In Fig.2, the DO-CCCII based DO-CF is given [8]. In this case, the constitutive relation of the DO-CCCII based DO-CF converts to the following equations.

$$v_x = i_x R_x, \quad i_{z+} = +i_x \quad \text{and} \quad i_{z-} = -i_x \quad (2)$$

where R_x is the parasitic resistance at the terminal x, which is equal to

$$R_x = \frac{V_T}{2I_O} \quad (3)$$

where V_T is the thermal voltage, and I_O is an external DC bias current that is tunable over several decades [9].

III. PROPOSED CIRCUIT CONFIGURATION

The proposed electronically tunable current-mode universal biquadratic filter with a minimum number of active and passive components is illustrated in Fig.3. By the utilization of the DO-CCCII-based CF, the circuit consists of only two DO-CFs and two grounded capacitors without requiring any external passive resistor. In addition, the use of grounded capacitors is helpful for easing the elimination of various parasitic capacitance effects [10]-[11]. Routine circuit analysis using the DO-CF characteristics given in equation (2),

the current transfer function of the proposed current-mode filter in Fig.3 can be expressed as :

$$I_{out} = \frac{(s^2 R_{x1} R_{x2} C_1 C_2 + s R_{x2} C_2 + 1) I_3 - (s R_{x2} C_2) I_2 + I_1}{s^2 R_{x1} R_{x2} C_1 C_2 + s R_{x2} C_2 + 1} \quad (4)$$

where $R_{xi} (= V_T/2I_{Oi})$ and I_{Oi} ($i = 1, 2$) are R_x and I_O of the i -th DO-CF, respectively. From equation (4), it can be observed that :

- 1) The LP current response is obtained with $I_1 = I_{in}$ and $I_2 = I_3 = 0$;
- 2) The BP current response is obtained with $I_2 = I_{in}$ and $I_1 = I_3 = 0$;
- 3) The HP current response is obtained with $-I_1 = I_2 = I_3 = I_{in}$;
- 4) The BS current response is obtained with $I_2 = I_3 = I_{in}$ and $I_1 = 0$;
- 5) The AP current response is obtained with $I_2/2 = I_3 = I_{in}$ and $I_1 = 0$.

Thus, five standard types of biquadratic filter functions can be derived by properly connecting the input terminals. Also note that there are no critical component-matching conditions or cancellation constraints in the design

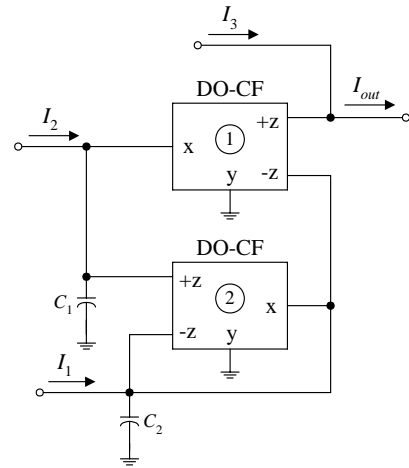

Figure 3 : Proposed current tunable current-mode biquadratic filter

Furthermore, from equation (4), the natural angular frequency (ω_o) and the bandwidth (BW) of the proposed circuit can be expressed as :

$$\omega_o = \frac{1}{\sqrt{R_{x1} R_{x2} C_1 C_2}} \quad (5)$$

and

$$BW = \frac{\omega_o}{Q} = \frac{1}{R_{x1} C_1} \quad (6)$$

It should be noted from equations (5) and (6) that the parameters ω_o and BW are adjustable orthogonally and electronically. Accordingly, the ω_o can be tuned electronically without disturbing BW by changing R_{x2} (or I_{O2}).

IV. TRACKING ERROR ANALYSIS

In this section, the effects of the active non-idealities of the DO-CF on the filter performance are studied in details. Taking into consideration of the DO-CF non-idealities, the terminal relation in equation (2) can be rewritten as :

$$v_x = i_x R_x \quad , \quad i_{z+} = +\beta_p i_x \quad \text{and} \quad i_z = -\beta_n i_x \quad (7)$$

where $\beta_p = (1 - \varepsilon_p)$ and $\beta_n = (1 - \varepsilon_n)$. Here, ε_p and ε_n ($|\varepsilon_p|, |\varepsilon_n| \ll 1$) denote the current tracking errors from x to +z and to -z terminals of the DO-CF, respectively. Reanalysis of the proposed filter circuit in Fig.3 yields the non-ideal characteristic polynomial as follows.

$$D_n = s^2 R_{x1} R_{x2} C_1 C_2 + s [R_{x2} C_2 + R_{x1} C_1 (1 - \beta_{n2})] + (1 - \beta_{n2}) + \beta_{n1} \beta_{p2} \quad (8)$$

where β_{pi} and β_{ni} ($i = 1, 2$) denote the above mentioned parameters associated with the i -th DO-CF. In this case, the modified natural frequency and bandwidth can be written as :

$$\omega_o = \sqrt{\frac{\beta_{n1} \beta_{p2} - \beta_{n2} + 1}{R_{x1} R_{x2} C_1 C_2}} \quad (9)$$

$$\text{and} \quad BW = \frac{\omega_o}{Q} = \frac{1}{R_{x1} C_1} + \frac{(1 - \beta_{n2})}{R_{x2} C_2} \quad (10)$$

From equations (9) and (10), it can be seen that the values of the parameters ω_o and BW may be altered slightly by the effects of the DO-CF tracking errors. However, due to the fact that R_x can still be adjusted via an external bias current I_O . Therefore, the deviations in the ω_o and BW parameters can easily be compensated by slightly tuning the bias currents I_{O1} and I_{O2} .

The sensitivity analysis with respect to the active and passive components can be calculated as follows :

$$S_{R_{x1}, R_{x2}, C_1, C_2}^{\omega_o} = -\frac{1}{2} \quad (11)$$

$$S_{\beta_{n1}, \beta_{p2}}^{\omega_o} = \frac{1}{2} \left(\frac{\beta_{n1} \beta_{p2}}{\beta_{n1} \beta_{p2} - \beta_{n2} + 1} \right) \quad (12)$$

$$S_{\beta_{n2}}^{\omega_o} = -\frac{1}{2} \left(\frac{\beta_{n2}}{\beta_{n1} \beta_{p2} - \beta_{n2} + 1} \right) \quad (13)$$

$$S_{\beta_{p1}}^{\omega_o} = 0 \quad (14)$$

$$S_{R_{x1}, C_1}^{BW} = -\frac{R_{x2} C_2}{R_{x2} C_2 + R_{x1} C_1 (1 - \beta_{n2})} \quad (15)$$

$$S_{R_{x2}, C_2}^{BW} = -\frac{R_{x1} C_1 (1 - \beta_{n2})}{R_{x2} C_2 + R_{x1} C_1 (1 - \beta_{n2})} \quad (16)$$

$$S_{\beta_{n1}, \beta_{p1}, \beta_{p2}}^{BW} = 0 \quad (17)$$

$$\text{and} \quad S_{\beta_{n2}}^{BW} = -\frac{\beta_{n2} R_{x1} C_1}{R_{x2} C_2 + R_{x1} C_1 (1 - \beta_{n2})} \quad (18)$$

Therefore, all the active and passive sensitivities are less than unity in magnitude.

V. SIMULATION RESULTS

The performance of the proposed electronically tunable current-mode biquadratic filter in Fig.3 has been simulated using PSPICE to verify the given theoretical prediction. In the simulations, the DO-CF has been simulated using the DO-CCCII based structure given in Fig.2 with the transistor model of PR100N (PNP) and NP100N (NPN) of the bipolar arrays ALA400 from AT&T [12]. The supply voltage were chosen to be $\pm V = \pm 3V$.

To realize the filter response with the natural angular frequency of $f_o \cong 122.4$ kHz, and the quality factor of $Q = 1$, the component values were selected as : $I_{O1} = I_{O2} \cong 100$ μA , $C_1 = C_2 = 10$ nF. Fig.4 shows the resulting frequency characteristics of LP, BP, HP and BS obtained from the simulations. With the component values given previously, the simulated AP response comparing with the theory is also given in Fig.5. The deviation of the phase response in Fig.5 stems mainly from the effects of the DO-CF non-idealities

The electronically tunable property of the proposed AP filter for different bias current values and corresponding phase responses are depicted in Fig.6 when I_O is respectively varied to 25, 50 and 100 μA . The results obtained from the simulations show that the corresponding f_o are about at 30.62, 61.2 and 122.4 kHz, which are in good agreement with theoretical values $f_o = 30.4, 60.53$ and 117.76 kHz, respectively

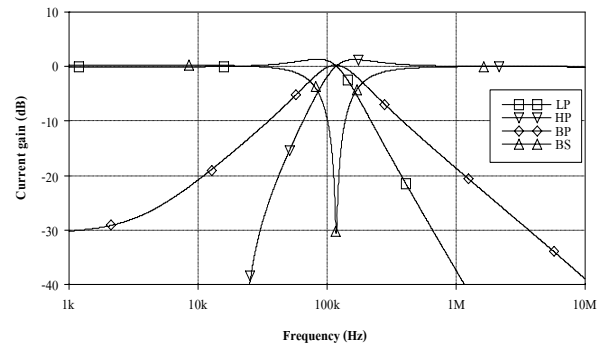

Figure 4 : Simulated current responses for LP, BP, HP and BS of the proposed current-mode filter of Fig.3.

Fig.7 show the simulation and theoretical responses of the BP filter for various values of $I_O (= I_{O1} = I_{O2})$. For this case, the theoretically calculated f_o was respectively 30.61 kHz, 61.2 kHz and 122.4 kHz, while the corresponding f_o obtained from simulations are respectively located at value of $f_o = 30.4$ kHz, 60.53 kHz and 117.76 kHz, respectively.

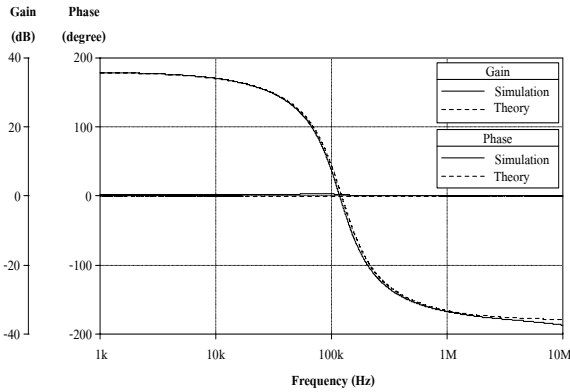

Figure 5 : Theory and simulated responses of the AP filter

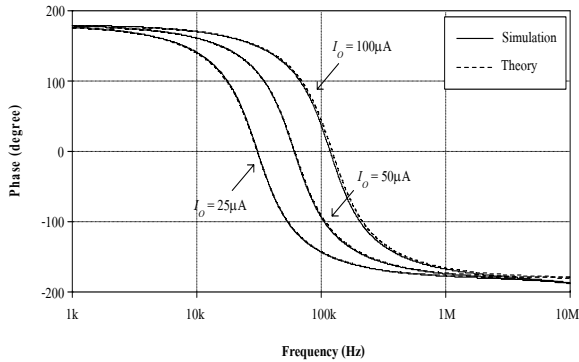

Fig. 6 Simulated phase responses of the AP filter when $I_O (= I_{O1} = I_{O2})$ is varied.

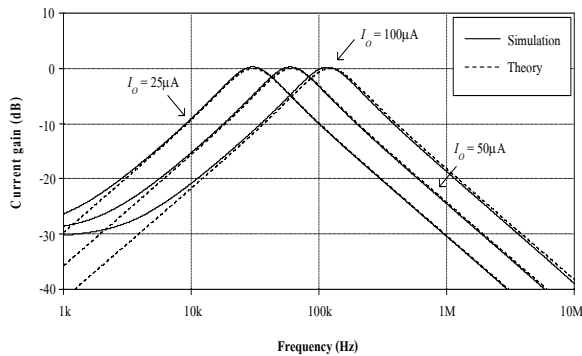

Fig. 7 Simulation frequency responses variation of f_o as a function of I_O for the BP filter

VI. CONCLUSIONS

A current-tunable current-mode universal biquadratic filter with a minimum number of active and passive components using DO-CFs is proposed. By utilizing the advantage of the parasitic resistance R_x of the DO-CCCII, the circuit requires only two DO-CFs and two grounded capacitors, which is attractive for the IC implementation point of view. By properly connecting the input signals, the proposed filter can realize the LP, BP, HP, BS and AP current responses from the same circuit configuration without component matching conditions. The ω_o can be adjusted electronically and independently from the tuning of the BW. The filter also has low passive and active sensitivities..

REFERENCES

- [1] M.A. Ibrahim, S. Minaei, H. Kuntman, "A 22.5 MHz current-mode KHN-biquad using differential voltage current conveyor and grounded passive elements", *Int. J. Electron.*, vol.59, pp. 311-318, 2005.
- [2] S. Celma, J. Sabadell, P. Martinez, "Universal filter using unity-gain cells", *Electron. Lett.*, vol.31, pp.1817-1818, 1995.
- [3] M.T. Abuelmaatti, M.A. Al-Qahtani, "Current-mode universal filters using unity-gain cells", *Electron. Lett.*, vol.32, pp.1077-1079, 1996.
- [4] H.A. H.A. Alzahrer, M. Ismail, "Current-mode universal filter using unity-gain cells", *Electron. Lett.*, vol.35, pp.2198-2200, 1999.
- [5] R.M. Weng, J.R. Lai, M.H. Lee, "New universal biquad filters using only two unity-gain cells", *Int. J. Electron.*, vol.87, pp.57-61, 2000.
- [6] C.M. Chang, T.S. Liao, T.Y. Yu, E.S. Lin, CH. Teng, CL. Hou, "Novel universal current-mode filters using unity-gain cells", *Int. J. Electron.*, vol.88, pp.23-30, 2001.
- [7] R. Senani, S.S. Gupta, "New universal filter using only current follower as active elements", *Int. J. Electron.*, vol.60, pp.251-256, 2006.
- [8] A. Fabre, O. Saaid, F. Wiest, C. Boucheron, "Current controllable bandpass filter based on translinear conveyors", *Electron. Lett.*, vol.31, pp.1727-1728, 1995.
- [9] W. Kiranon, J. Kesorn, P. Wardkien, "Current controlled oscillator based on translinear conveyors", *Electron. Lett.*, vol.32, pp.1330-1331, 1996.
- [10] M. Bhusan, R.W. Newcomb, "Grounding of capacitors in integrated circuits", *Electron. Lett.*, vol.3, pp.148-149, 1995.
- [11] K. Pal, R. Singh, "Inductorless current conveyor allpass filter using grounded capacitors", *Electron. Lett.*, vol.18, pp.47, 1982.
- [12] D.R. Frey, "Log-domain filtering an approach to current-mode filtering", *IEE Proc. G, Circuit, Devices and Systems*, vol.140, pp.406-416, 1993.