



Title	Application of the Stroboscopic Correlation to Acoustic Response Measurement
Author(s)	Idogawa, T.; Ibaragi, O.
Citation	Memoirs of the Faculty of Engineering, Hokkaido University, 14(1), 113-123
Issue Date	1975-03
Doc URL	http://hdl.handle.net/2115/37935
Type	bulletin (article)
File Information	14(1)_113-124.pdf



[Instructions for use](#)

Application of the Stroboscopic Correlation to Acoustic Response Measurement

T. IDOGAWA*

O. IBARAGI*

(Received, July 30, 1974)

Abstract

This paper describes some applications of the stroboscopic correlation method, in a paper presented previously, in which the correlation function was readily obtained without the aid of computers. Impulse responses, or input-output cross-correlation functions, of acoustic filters are determined by this method using the sound wave generated by m -sequences as the input. This procedure eliminates disturbances that result not only from reflected waves from distant objects but also from the noise uncorrelated with the input. Determinations of responses of cavities and flutes are carried out in an ordinary room without any special devices to reduce reflections. The experimental results confirmed the known properties of the cavity and the flute. This demonstrates the practical applicability of the method.

1. Introduction

The frequency response of an acoustic system determined directly, when stimulated by sinusoidal inputs of varying frequencies. An advantage of impulse excitation, in place of the sinusoidal excitation, lies in the elimination of disturbances that result from reflections of distant objects¹⁾.

The impulse response is also determined by an input-output cross-correlation function, when the system is excited by a noise signal whose autocorrelation function can be considered to be a δ -function. This procedure eliminates disturbances of noise which is uncorrelated with the input and increases the power of the signal compared with the single impulse input.

It was reported in the previous papers^{2)~6)} that a correlation function could be obtained by a method similar to the stroboscopic observation without using computers. This stroboscopic correlation method was proved to be applicable theoretically not only to truly periodic signals but also apparently preiodic signals such as a piece of random signal given from an endless magnetic tape. From a practical point of view it was remarkably useful when a signal of m -sequences was used.

The purpose of this paper is to demonstrate the usefulness of the stroboscopic correlation method in determining impulse responses of the acoustic filters, espe-

* Department of Applied Physics, Faculty of Engineering, Hokkaido University, 060 Sapporo, Japan.

cially when the signal of m -sequences are employed. Experiments were carried out in an ordinary room without any special devices to reduce reflections. Section 2 reviews the outline of the stroboscopic correlation method and describes its application to the response determination of an acoustic system. Section 3 is devoted to the response determination of cavity resonance. Section 4 gives some measured properties of a flute.

2. Stroboscopic Correlation Using m -sequences

Such properties of m -sequences which are required to understand this paper are cited below for the readers' convenience. The signal of m -sequences can be generated by a shift register with proper feedbacks. For an n -stage shift register, driven by shiftpulses of a period T , the length of m -sequence is $(2^n - 1) \cdot T$. For autocorrelation purposes, it is convenient for the two states of sequence to be $+1$ and -1 . The autocorrelation function then assumes the shape shown in Fig. 1, being periodic with the same period as that of the sequence.

The impulse response $h(t)$ of a linear system can be determined from the input-output cross-correlation. Being stimulated by a signal of an m -sequence $m(t)$, the linear system delivers an output $f(t)$ of the same period as the input. The input-output cross-correlation function $\phi_{mf}(\tau)$ is expressed by a convolution integral as follows:

$$\phi_{mf}(\tau) = \int_{-\infty}^{\infty} h(\sigma) \cdot \phi_{mm}(\tau - \sigma) d\sigma \quad (1)$$

where $\phi_{mm}(\tau)$ is the autocorrelation function of the m -sequence signal. If the autocorrelation function can be assumed to be a δ -type impulse, namely

$$\phi_{mm}(\tau) = \delta(\tau), \quad (2)$$

the cross-correlation function gives the impulse response of the linear system:

$$\phi_{mf}(\tau) = h(\tau). \quad (3)$$

The block diagram of the stroboscopic correlation method is shown in Fig. 2. Two m -sequences generators, shift registers with proper feedbacks, were constructed in exactly the same manner. They were driven by shift pulses given from oscillators, which were adjusted in such a way that their oscillating fre-

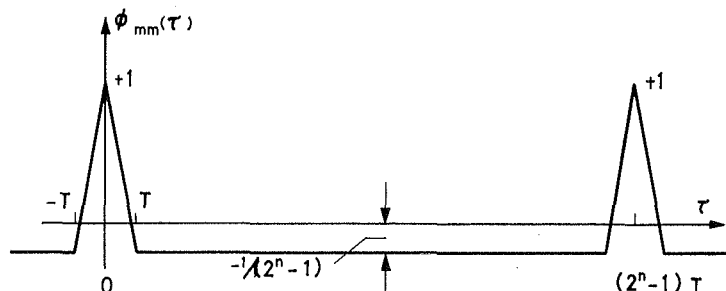

Fig. 1. Autocorrelation function of an m -sequence signal.

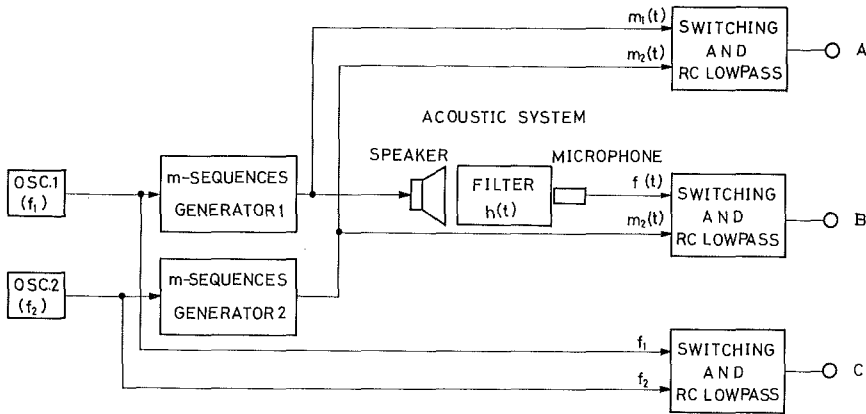

Fig. 2. The block diagram of the stroboscopic correlation method using the signal of m -sequences.

frequencies f_1 and f_2 were slightly different. Two m -sequence signals $m_1(t)$ and $m_2(t)$ had exactly the same waveform and slightly different periods. Terminal A delivered the beat waveform of $m_1(t)$ and $m_2(t)$, or the autocorrelation $\phi_{mm}(\tau)$. Terminal B delivered the beat waveform of $f(t)$ and $m_2(t)$, or the input-output cross-correlation $\phi_{mf}(\tau)$. If a speaker in Fig. 2 would have been stimulated by the impulsive input $\phi_{mm}(\tau)$, the approximate impulse response $\phi_{mf}(\tau)$ of the acoustic filter including the speaker and microphone would be obtained. The time scale of these correlation functions was given by the time mark signal at terminal C, which gave the beat waveform of outputs from the two oscillators. The ratio of the time mark period to the period $1/f_1$ was the magnification factor of the time scale.

The dynamic characteristics of acoustic systems are given largely in the form of frequency response. The input-output relation in the frequency domain is described by the Fourier transform of the Eq. (1):

$$\Phi_{mf}(j\omega) = F(j\omega) \cdot \Phi_{mm}(j\omega). \quad (4)$$

Here $F(j\omega)$ is the frequency response function of the acoustic system including the speaker and microphone, $\Phi_{mm}(j\omega)$ is the power spectrum of the signal $m(t)$ and $\Phi_{mf}(j\omega)$ is the cross power spectrum. With the acoustic filter removed the microphone receives directly the sound emitted from the speaker and delivers the output $g(t)$. The input-output relation in the frequency domain must satisfy

$$\Phi_{mg}(j\omega) = G(j\omega) \cdot \Phi_{mm}(j\omega), \quad (5)$$

where $G(j\omega)$ is the frequency response function of the system consisting only of the speaker and microphone used. Therefore, the frequency response function $H(j\omega)$ of the acoustic filter may be expressed by

$$H(j\omega) = \Phi_{mf}(j\omega) / \Phi_{mg}(j\omega), \quad (6)$$

provided that

$$F(j\omega) = G(j\omega) \cdot H(j\omega).$$

This procedure cancels out the frequency response of the speaker and microphone. A loud speaker has generally a rather narrow passband compared with that of the signal of m -sequences, which is adjusted beforehand to have a sufficient band width.

2. Cavity Resonance

The stroboscopic correlation method was applied to the determination of cavity resonance using the signal of m -sequences.

The ratio of the pressure amplitude at the closed end p_i to that at the open end p_o of a circular tube with a large flange is given by the equation⁷⁾:

$$p_i/p_o = \left\{ \left[1 - 2 \frac{J_1(\tau\omega)}{\tau\omega} \right] \sin^2 \left(\frac{2\pi l}{\lambda} \right) + \left[M(\tau\omega) \sin \left(\frac{2\pi l}{\lambda} \right) - \cos \left(\frac{2\pi l}{\lambda} \right) \right]^2 \right\}^{-1/2}, \quad (8)$$

where λ is the sound wave length, a the radius of the tube, l its length and $\omega = 4\pi a/l$. $J_1(\omega)$ is a first order Bessel function and $M(\omega)$ is the acoustic reactance ratio for the open end:

$$M(\omega) = \frac{4}{\pi} \int_0^{\pi/2} \sin(\omega \cos \alpha) \sin^2 \alpha \, d\alpha. \quad (9)$$

The ratio p_i/p_o was calculated from the values $a=0.80$ cm, $l=25.0$ cm and at temperature 10°C , in accordance with the experimental conditions, with the aid of a digital computer. The calculated curve of p_i/p_o against frequency is shown in Fig. 3.

The impulse response determination was carried out in an ordinary room

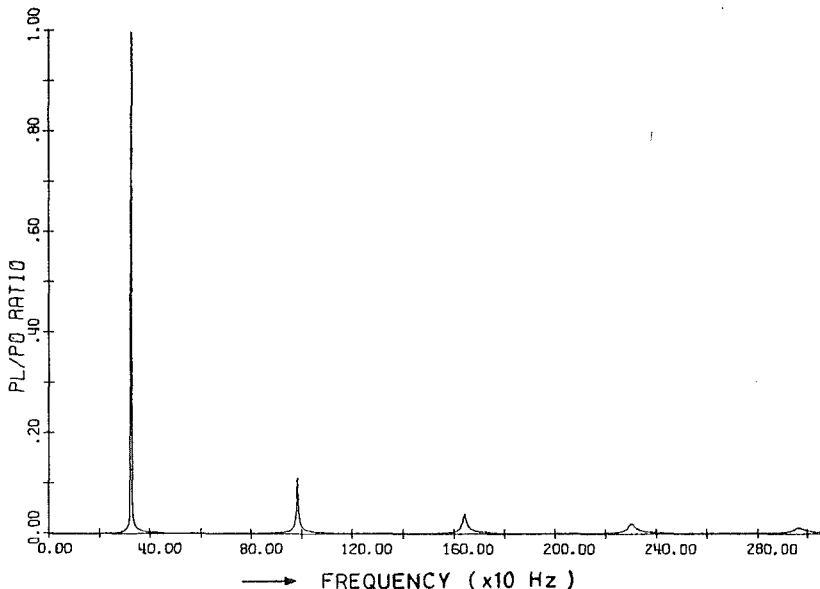

Fig. 3. Frequency response $p_i/p_o(\omega)$ of a closed tube, calculated from the values: radius $a=0.80$ cm, length $l=25.0$ cm, at temperature 10°C .

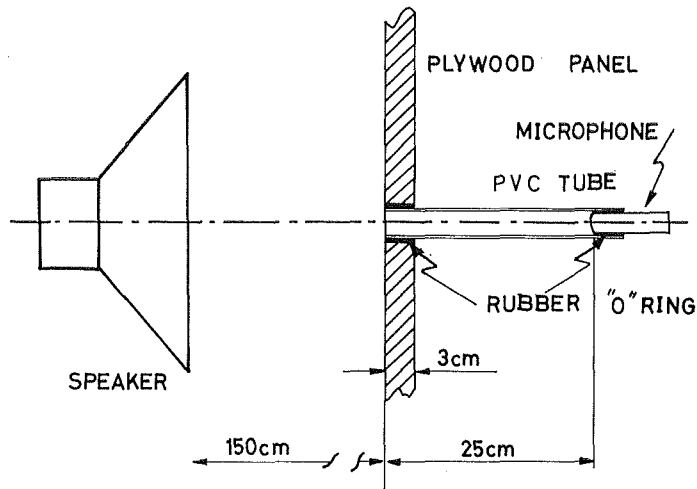

Fig. 4. The setup used to determine the resonances of a closed tube with a large baffle plate.

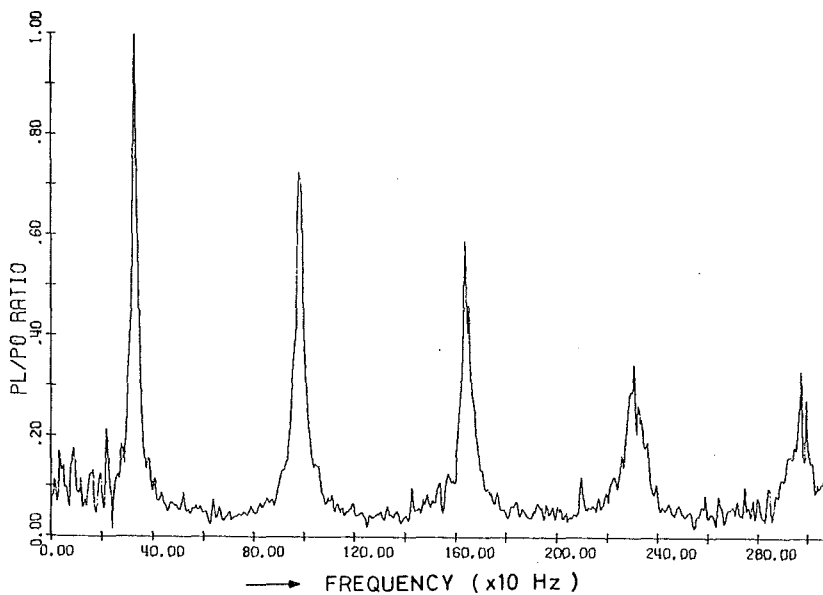

Fig. 5. The measured frequency response $p_i/p_o(\omega)$ of a closed tube: radius $a=0.80$ cm, length $l=25.0$ cm, at room temperature 10°C . The signal of an m -sequence used: period $N=2^{11}-1=2047$ shift pulse frequency 10 kHz.

without any special devices to reduce reflections. Figure 4 shows the setup used. Plane waves from a speaker fell on the open end of a polyvinyl chloride (PVC) tube fitted with a large flange and closed by a condenser microphone at the other end. The baffle, a plywood panel of $180 \times 90 \times 3$ cm, was supported by a wooden frame and located near the center of the room. A PVC tube with an inner

diameter of 1.60 cm was fitted with the circular hole at the center of the panel and fixed tightly by a thin rubber "0" ring. At the other end, a condenser microphone was inserted into the tube and was also fixed tightly by a thin rubber "0" ring. A loud speaker was placed 150 cm from the panel surface, with its center on the axis of the PVC tube.

The room temperature variation was estimated to be less than 1 deg near 10°C during the experiment. The length of the closed tube was determined to an accuracy of ± 1 mm. Truly accurate determination was difficult because of the spherical head cover of the microphone. These led to errors of fundamental frequency estimation amounting to ± 2.2 Hz at around 340 Hz.

The signal to stimulate the speaker was adjusted to have a resolution of 4.88 Hz, namely, the 11-stage m -sequences generator was driven by shift pulses of 10 kHz. The period of the m -sequence signal used was sufficiently long compared with the duration of the impulse response to be measured. The shift pulse frequency was sufficiently high compared with the highest resonant frequency to be measured.

With the microphone located at $l=25.0$ cm a signal $f(t)$ was obtained. The stroboscopic correlation method gave in real time the input-output cross-correlation function $\phi_{mf}(\tau)$, which was tape recorded. With the microphone located at $l=0$ cm a signal $g(t)$ was obtained and the cross-correlation function $\phi_{mg}(\tau)$ was also tape recorded in the same manner. Fourier transformation of these correlation functions and division were carried out by digital computer, and the pressure amplitude ratio was obtained as follows:

$$p_l/p_o = \left| \Phi_{mf}(j\omega) \right| / \left| \Phi_{mg}(j\omega) \right|. \quad (10)$$

A typical example was shown in Fig. 5.

The resonances obtained by the correlation method show lower Q -values com-

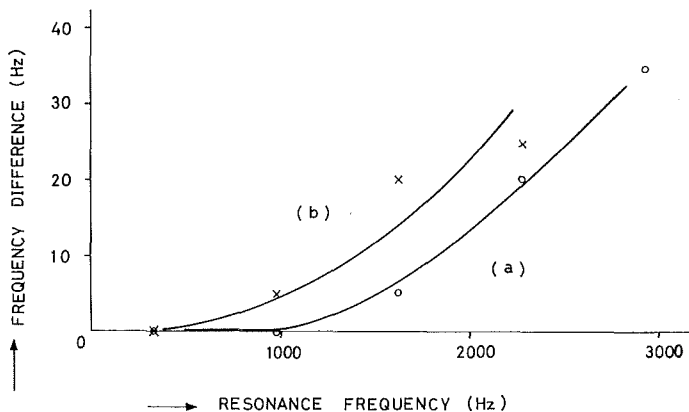

Fig. 6. Higher harmonics of a closed tube differ from the integral multiples of the fundamental resonant frequency. Curve (a): with baffle. Curve (b): without baffle.

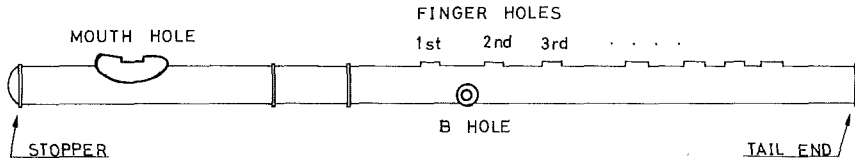

Fig. 7. A flute.

pared with those of the calculated; the acoustic loss of the cavity was not taken into consideration in Eq. (8). Frequencies ν_n of higher harmonics are slightly higher than the integral multiples of the fundamental frequency ν_1 , that is to say,

$$\nu_n = n \cdot \nu_1 + \varepsilon(n), \quad n = 3, 5, 7, \dots$$

where $\varepsilon(n)$'s are positive values. With the baffle removed resonances were also measured. Q -values were lower and $\varepsilon(n)$'s were larger compared with the results obtained with the baffle. Figure 6 shows the values of $\varepsilon(n)$: curve (a) measured with the baffle and (b) measured without the baffle.

4. Flute Resonance

The flute here is a closed tube with several holes as shown in Fig. 7. Its response was analysed successfully with the aid of circuit analogy⁸⁾. When the stopper of the flute is fixed carefully at the right tuning position, resonant frequencies can be determined by fingering the flute holes and covering the mouth hole.

Experiments were carried out in an ordinary room with no effort to reduce reflections. A flute was hung by fine steel wires from a wooden frame which was located in the middle of the room. According to the fingering some of the finger holes were closed. A condenser microphone was fitted to one of the finger holes which should have been closed according to fingering. The mounting of the microphone was as shown in Fig. 8.

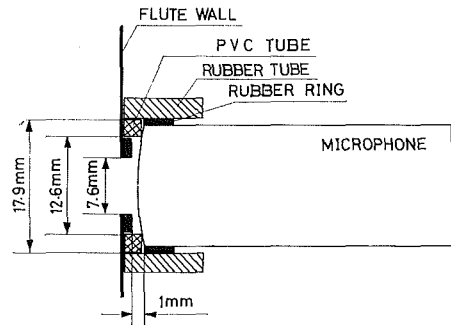

Fig. 8. A fitting of a condenser microphone to a finger hole of the flute.

In accordance with the error expected from the experimental conditions, the signal to stimulate the acoustic system was adjusted to have a resolution of 4.88 Hz; namely, the 11-stage m -sequence generator was driven by shift pulses of 10 kHz.

As a preliminary test the flute was stimulated by the sound waves from a speaker which was located 1 m from the flute and was driven by the m -sequences generator. With the condenser microphone fitting the B-hole an impulse response of the flute was obtained. Sensitivities of the speaker and microphone were compensated in the frequency domain in the same manner described in relation to Eq. 6. Sharp resonances were seen: at 392 Hz by G-fingering (392 Hz); also at 440 Hz and 900 Hz by A-fingering (440 Hz) which is to produce also A'tone (880

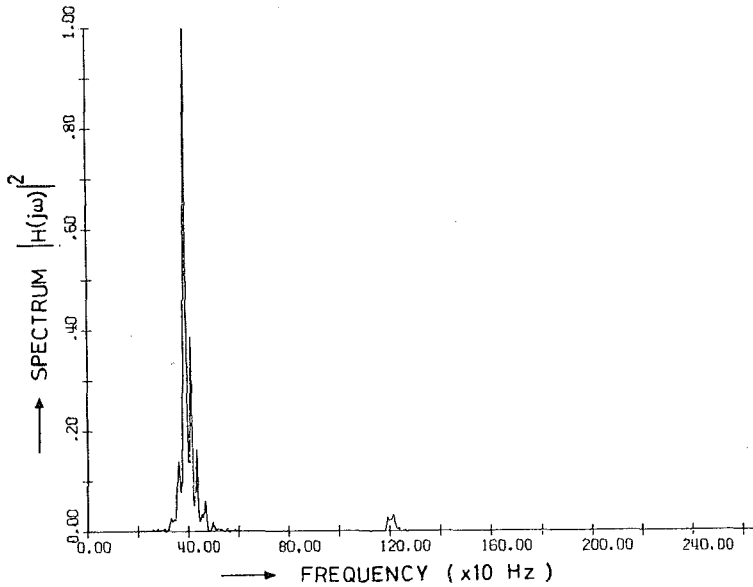

Fig. 9. Resonance of the flute was seen at 392 Hz when some finger holes were closed according to G-fingering (392 Hz). Sound source was placed at the third finger hole, microphone at the B-hole.

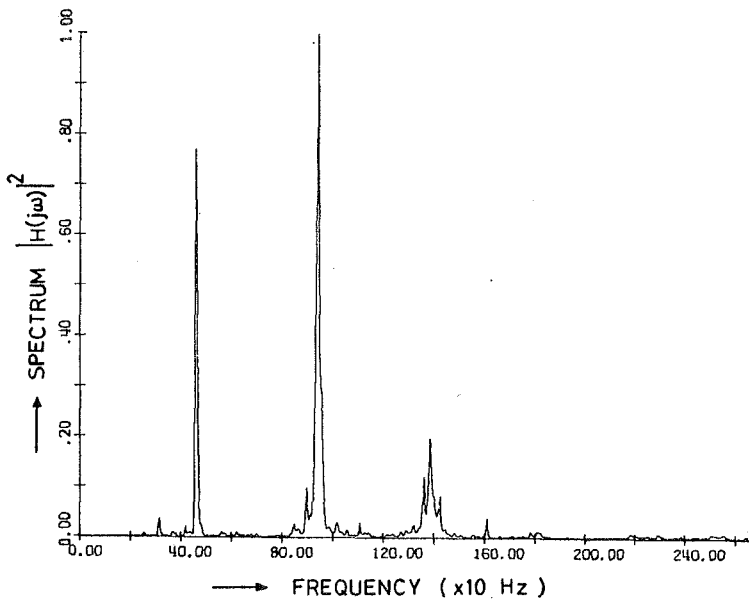

Fig. 10. Resonances of the flute were seen at 459 Hz and at 942 Hz. Some finger holes were closed according to A-fingering (440 and 880 Hz by overblowing). Sound source was placed at the B-hole, microphone was in place of the stopper.

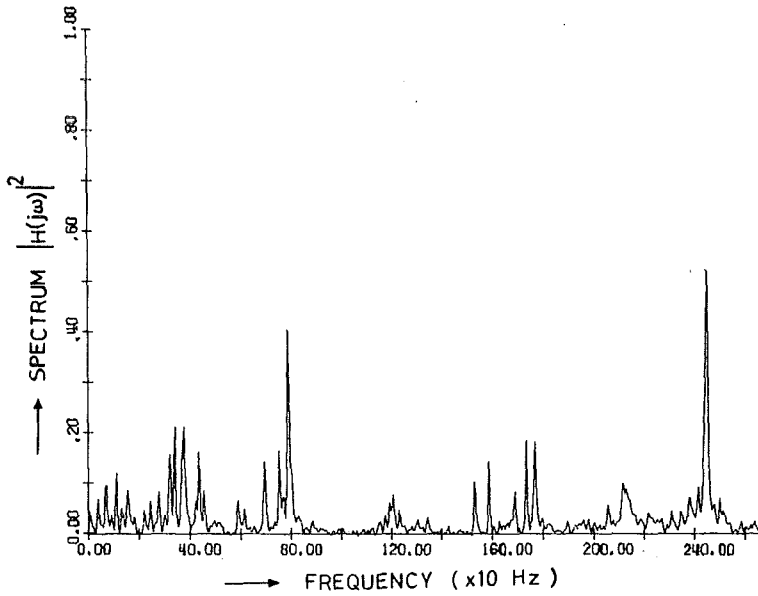

Fig. 11. Resonances were not observed in the flute tone range, when the microphone was placed at a few centimeters from the tail end, outside of the flute. Sound source: at the B-hole. Fingering: A (440 and 880 Hz by overblowing).

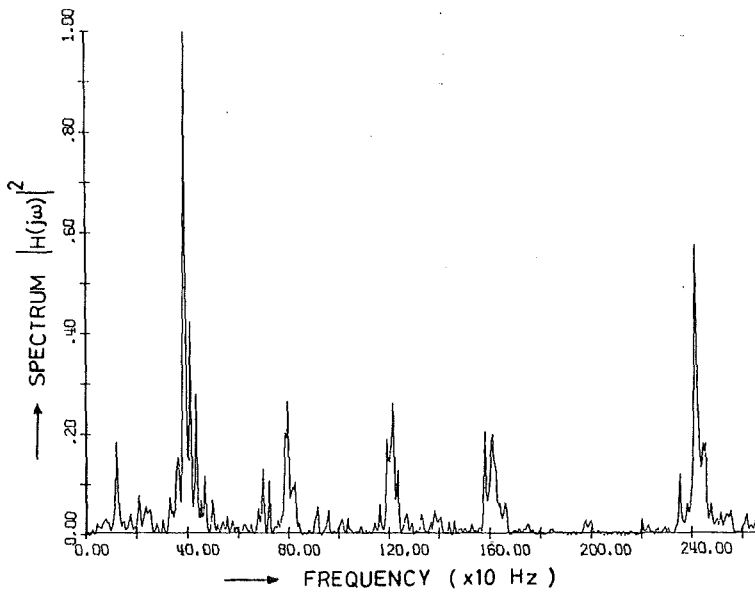

Fig. 12. Frequency response of the flute. Some finger holes were closed according to G-fingering (392 Hz). Sound source: at the third finger hole. Microphone: at the mouth hole.

Hz) by overblowing.

In order to define precisely the location of the sound source, a small earphone, driven by the m -sequences generator, was mounted on one of the holes of the flute. Sensitivities of the earphone and the microphone were compensated. With the earphone set at the third finger hole and the microphone at the B-hole, resonances were obtained. This resembled closely the results which were obtained by the stimulation from the speaker outside of the flute. The third harmonics peak was rather low as shown in Fig. 9. With the microphone in place of the stopper or in front of the mouth hole higher harmonics peaks were noted. Figure 10 shows the resonance by A-fingering.

It was confirmed by several measurements that: the frequency response does not depend on the location of the sound source but on the location of the microphone; the microphone is fixed in place of the stopper, it is the most convenient location for the measurement.

With the microphone placed few centimeters from the tail end, outside of the flute, the resonances in the flute tone range were not observed. A typical example shown in Fig. 11 was obtained by placing the sound source at B-hole. This was confirmed also by other locations of the sound source; at the mouth hole, B-hole, the third finger hole.

It is known that the frequencies of the higher harmonics do not coincide with the integral multiples of the fundamental frequency. A typical example shown in Fig. 12 was obtained according to G-fingering and with the placing of the earphone at the third finger hole and the microphone at the mouth hole. According to A-fingering resonance frequencies were plotted in Fig. 13 by the curve (b). The effective length of the flute is rather short in lower frequency ranges and rather long in higher frequency ranges. When the half of the mouth hole was covered by a plastic plate, the effective length change was not remarkable as shown also in Fig. 13 by the curve (a).

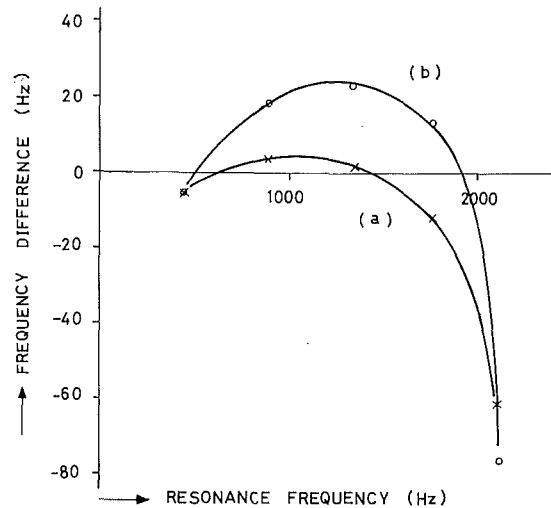

Fig. 13. Frequencies of the higher harmonics differed from the integral multiples of the fundamental frequency of the flute. Curve (a): frequency difference when the mouth hole was partially covered. Curve (b): frequency difference with this coverage removed. Sound source was placed at the mouth hole and the microphone was in place of the stopper. Some finger holes were closed according to A-fingering (440 and 880 Hz by overblowing).

5. Conclusions

It is the purpose of this study to demonstrate the applicability of the stroboscopic correlation method using m -sequences for identifications of the acoustic systems. The input-output cross-correlation functions of a closed tube and of a flute, which closely resembled the impulse responses, were Fourier transformed in order to compare the results with known properties in the frequency spectrum. Also the sensitivities of the speaker and microphone were compensated in the frequency domain.

(A) Measured resonant frequencies of a closed tube with a baffle agreed with the calculated values.

(B) Well known properties of the flute were confirmed: (1) the stopper is replaced by the microphone, at that position the microphone gives the most accurate responses; (2) the flute tone is not emitted from the tail end; (3) the effective length is rather short in lower frequency ranges and rather long in higher frequency ranges; (4) the effective length change is not remarkable when the mouth hole is partially covered.

Accurate determination of an impulse response of the acoustic system were readily carried out in a short time by the stroboscopic correlation method using m -sequences signals. Fourier transformation was not necessary unless the result is to be studied in the frequency domain. Experiments were carried out in an ordinary room without any special devices to reduce reflections.

Acknowledgement

We are greatly indebted to Dr. M. Kitamura of Hokkaido University for his critical reading of the manuscript.

References

- 1) P. Hohmann and M. M. Loudon: *Acustica*, **29** (1973) 40.
- 2) T. Isobe and T. Idogawa: *Japan J. Appl. Phys.*, **3** (1964) 780.
- 3) T. Isobe, T. Idogawa and H. Kashiwagi: *IFAC Symposium London* (1966).
- 4) T. Idogawa: *Transactions of the Society of Instrument and Control Engineers* **1** (1965) 174. (in Japanese).
- 5) T. Idogawa: *Transactions of the Society of Instrument and Control Engineers* **4** (1968) 61. (in Japanese).
- 6) T. Idogawa: *Transactions of the Society of Instrument and Control Engineers* **4** (1968) 69. (in Japanese).
- 7) P. M. Morse: *Vibration and Sound* (McGraw-Hill, New York: 1948).
- 8) A. H. Benade and J. W. French: *J. Acoust. Soc. Amer.* **37** (1965) 679.